

IRB 5400

High performance paint process robot

A highly efficient paint robot with high acceleration, high load capacity, large work envelope and integrated process equipment.

It saves cycle time and it saves paint.



A powerful workhorse

The IRB 5400 is a unique paint robot with high acceleration and speed, combined with the ability to carry heavy loads. It gives you short cycle times and increased production. The extensive load capacity enables us to put the process equipment close to the applicator to reduce waste.

Powered by IPS

The integrated process system (IPS) integrates the paint application equipment in the robot arm. With color change valves and paint pumps close to the paint wrist, the result is reduced material consumption and significant paint savings.

Air- and fluid regulation, pilot valves, flow sensors, bell speed- and high voltage control are also integrated in the robot, making installation, set up and process tuning fast and easy.

Paint robot control system

The IRB 5400 uses the IRC5P paint robot control system. It is specifically designed for the paint shop with its user friendly Ex FlexPaint Pendant and RobView 5 - our paint cell software for supervision, control and diagnostics, and our powerful software tools for off-line programming and process tuning.

Add a rail for coating large objects

The IRB 5400 can be mounted on a trolley for operating on a rail. There are two types of foot for the trolley. The clean wall foot is used when the trolley and rail is located outside the spray booth. This enables for an easy-to-clean inner spray booth wall. The in-booth foot enables the complete rail and trolley to be located inside the spray booth. This design is typically used for retrofit in existing spray booths or for spray booths with limited space.

IRB 5400

High performance paint process robot

Designed for paint savings

The IRB 5400 is 'Powered by IPS', ABB's high speed integrated process system for closed loop air- and paint flow regulation and control.

Specification

Number of axes	6 axes. 7 when rail-mounted
Robot mounting	Floor and rail
Payload on wrist	25 kg
Load capacity on vertical arm	65 kg
Load capacity on horizontal arm	70 kg (including wrist payload)
Ingress protection degree	IP67, wrist IP54
Robot unit ambient temperature	+5°C to +45°C*
Relative humidity, non-condensing	95% maximum
Ex classification	II 2 G Ex ib px IIB T4 II 2 D Ex pD 21 T65°C FM Class I,II. Div.1, Group C,D,G 135°C
Robot controller ambient temperature	+48°C maximum
*Recommended max ambient temp <30°C	

Performance

Axis:	Working range:	Max. speed:
Rotation	300° 170° with riser foot	137°/s
Vertical arm	160°	137°/s
Horizontal arm	150°	137°/s
Inner wrist	Unlimited	465°/s
Wrist bend	Unlimited	350°/s
Wrist turn	Unlimited*	535°/s
Total wrist bend	+/- 140°	
Pose accuracy	0.1 mm	
Static repeatability	0.15 mm	
Path accuracy	+/- 3 mm	
Velocity	1.5 m/s	

*only limited by the hoses

Controller interfaces

I/O boards	Analog, digital, relay, 120VAC, encoder and process I/O boards available
Fieldbus support	Interbus-S, Profibus, Profinet, CC Link, DeviceNet and Ethernet IP available
Network	Ethernet FTP/NFS

PC tools

RobView 5 (included)	Paint cell supervision and operation
ShopFloor Editor	Off-line editing and process tuning
RobotStudio Paint	3D off-line simulation and programming

Work envelope

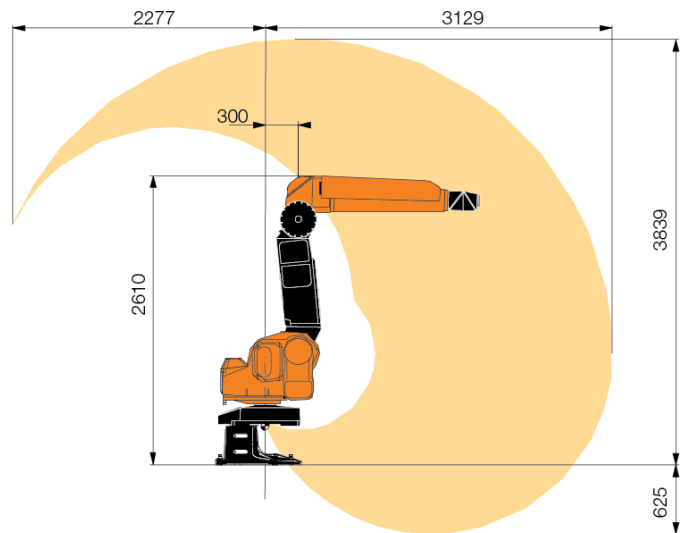

Physical

Robot footprint	660 x 750 mm (standard foot) 660 x 775 mm (riser foot) 633 mm x 2 - 15 m length* (rail)
Robot unit height (without foot)	2070 mm
Standard foot height	190 mm
Raiser foot height	540 mm
Clean wall rail foot height	700 mm
In-booth rail foot height	1125 mm
Vertical arm length	1200 mm
Horizontal arm length	1620 mm
Robot weight with standard foot	970 kg
Robot weight with riser foot	1060 kg
Robot Controller (H x W x D)	1450 x 725 x 710 mm
Robot controller weight	180 - 200 kg
*Longer rail lengths on request	

Flexible rail system



The rails are designed for minimum disturbance of the air flow and are available in 1.5 and 2 m modules that combine to the desired length, up to 15 meters (standard). One or two robots can be mounted on one rail.

Electrical connection

Mains voltage	200 - 600VAC, 3-phase, 50/60 Hz
Power consumption	Stand by <300 W, production 700-1500 W
Electrical safety	According to international standards
Information may be changed or updated without notice	