

How to use IEC 61850 in protection and automation

from Ivan de MESMAEKER¹

Introduction

The use of numerical technology in Protection and Automation has provided multi-functional equipment with serial communication. The introduction of serial communication some years ago resulted in the use of proprietary protocols for the communication of control and protection IEDs (Intelligent Electronic Devices) installed in the substation.

Of course, some IEC standards have been issued: an important one standardized the communication between substation and remote control centre (IEC 60870-5-101/104 [1], [2]), another one defined the protocol for the communication with protection equipment (IEC 60870-5-103 [3]). These two have been very well accepted but especially the IEC 60870-5-103 has shown its limited design: designed as master-slave protocol restricted to some protection functions and a relatively little number of standardized numbered data.

Users request an open protocol for all functions like protection, control and monitoring at least inside substations (see e.g. in [11]). Open means to have the possibility to make extension without being dependant on the manufacturer having delivered the previous parts of the substation equipment. This means also that third party equipment should be easily integrated in the system of another manufacturer.

The requested standard has to

- Cover all communication issues inside the substation
 - Assure interoperability between the functions existing inside the substation (as preliminary condition for interchangeability)
 - Support all types of architectures used, e.g. centralized ones similar to RTUs and

decentralized ones as used in fully developed substation automation system

- Be future-proof, i.e. to cope with the fast development in communication technology in the slow evolving application domain of power systems.

These are very ambitious goals because all functionality needed in substations had to be examined with respect to their communication behavior and requirements.

The resulting standard IEC 61850 [4] is now finalized but a joint group of users, editors and IEC working group members is collecting experience from the use of the standard, identifying points where clarification is needed and areas where extensions are requested. The result will be short-term amendments and long-term revisions. A challenge is the comprehensive range of the standard covering functional aspects, communication aspects, engineering aspects and conformity tests. For substation automation systems, first projects are now realized and the first experiences will be reported very soon.

Taking into consideration all the different dedicated activities related to protection and control inside substations it is also very important to establish a clear understanding, how the tasks have been solved until now and how they should be solved using the full power of the standard. The goal of this paper is to facilitate the understanding and to explain how easy the standard can be applied to exploit all applicable benefits. Therefore, a stepwise function-oriented approach is chosen covering

- SCADA application in the substation
- Time critical information exchange
- Connection of the primary process
- Design, test and commission
- Maintenance and extension

1. I. de MESMAEKER, Chairman of SC B5
2. Klaus-Peter BRAND, IEC expert
3. Christoph BRUNNER, IEC expert

Finally, an outlook is given to the future ongoing and proposed work based on the standard IEC 61850 and leading to seamless utility communication architecture.

How to use IEC 61850 for SCADA application in substations

Tasks

Supervisory control and data acquisition (SCADA) is one of the basic tasks of a substation automation system. This comprises:

- Local and remote operation of the switchgear and other high voltage equipment
- Acquisition of switchgear information and power system measurands
- Handling of events and alarms.

The SCADA application is related to human operation of the network and is performed by a local or remote operator. The data communication for this application is directed *vertically*, i.e. from a higher hierarchical control level down to a lower one (commands of any kind from the operators place) or reverse (binary indications like breakers or isolators position, measurands from instrument transformers and other sensors, events, alarms) as can be seen from Figure 1. It allows to operate and to supervise the power system.

is the process or bay level IED, which provides all data to the client at station or any remote level. The data are provided on request by the server or automatically by a report from the server issued if certain conditions are fulfilled. The client is mostly a computer representing the operator's work place. The client can send commands to the server for changing data in the server to:

- Issue commands for the operation of to the switchgear
- Modify the behavior of the server through the change of internal data (e.g. change of parameter sets, analog set-points, enabling or disabling functions)

In a client-server communication, the client controls the data exchange. Therefore, client-server communication is very flexible in terms of the data to be transmitted. Compared to a master slave system, the client-server concept allows the implementation of multiple clients in the same system. (Figure 1; e.g. both the gateway and the HMI are clients). Client-server communication relies on the full seven layer stack using a confirmed transmission layer and is, as consequence, very reliable but relatively time consuming. Therefore, the client-server communication is not suited for time-critical data transmission but very well for the communication with an operator having a response time of the order of 1 s.

IEC 61850 not only specifies the method of the data transfer. It defines as well the process data of the servers. For that purpose, IEC 61850 uses an object-oriented approach with Logical Nodes (LN) as core objects (see [5], [7]). A logical node is a functional grouping of data and represents the smallest function, which may be implemented independently in devices. Examples are all data of a circuit breaker contained in the Logical Node XCBR or all data of a timed overcurrent protection contained in the Logical Node PTOC. Therefore, the substation or protection engineer identifies easily the objects he knows from his daily work.

As outlined in Figure 2 all the Logical Nodes have data, and all the data have attributes. For example, the LN class ●●●

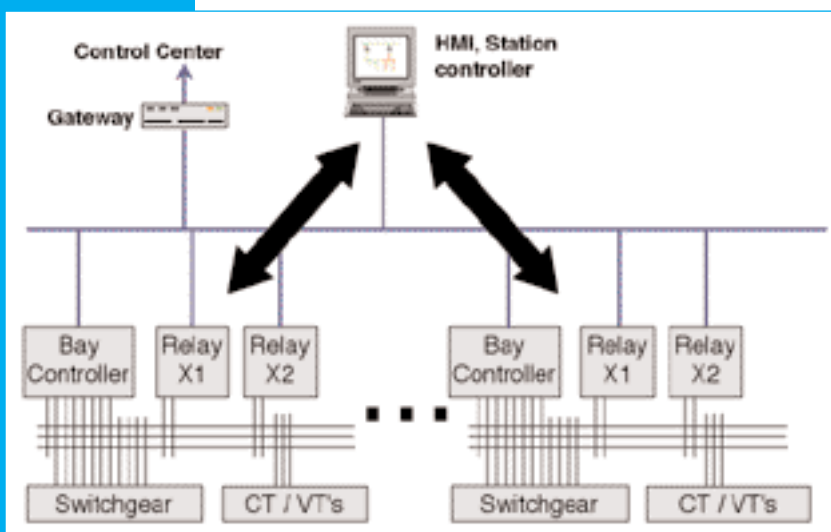

Figure 1: Vertical communication in the substation automation system with hardwired process interface

Model

For this vertical relationship IEC 61850 is using the client - server concept [5]. The server

XCBR (**Q0_XCBR**) has a data called **Pos**, with one attribute **stVal**, which indicates the position (values according the common double point indication: off, on, intermediate-state, bad-state) and another attribute **ctlVal** for the opening and closing command (values: off, on). The Logical Nodes, the data and the attributes including their names and semantic interpretation are defined by the standard.

Logical Nodes are grouped in Logical Devices. Example: Logical Device **Tampa_Protection** for a comprehensive two zone distance protection using one Logical Node PDIS per zone (**PDIS1** and **PDIS2** in Figure 2). By enabling or disabling a Logical Device, it is possible to enable and disable the contained group of Logical Nodes together.

Logical Devices are implemented in physical devices (IEDs). There is some actual information needed not only about the Logical Nodes and Logical Devices but also about the complete IED like the status of the common power supply. This information is modeled in the Logical Node **LPHD**, which has to be provided in each Logical Device (see Figure 2).

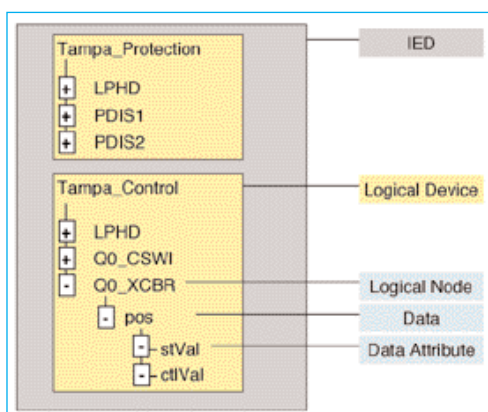

Figure 2:

Hierarchical data model and naming

An important aspect of a data model is the unambiguous identification of the data. According to IEC 61850, the name is created by the concatenation of the individual elements of the hierarchical data model: logical device, logical node instance, data and data attribute. Example for the status of the breaker Q0 in the bay Tampa: **Tampa_Control/Q0_XCBR.pos.stVal** (Figure 2).

To access the data, several services are standardized as part of the client-server concept. Besides the basic services to access the data model (individual read or write of data), more elaborated services are defined. As an example, for the SCADA application, event driven transmission of data is essential. In IEC 61850, the report service is defined for that purpose. The report service is not accessing individual data, but group of data called dataset. The details of the event driven transmission are defined in the report configuration block. An event causing a transmission may be a change of a binary value, the crossing of a predefined alarm limit or the expiration of a cycle time. Based on the report configuration block and the related dataset, reports are sent to the client. Including the time tag of the event as part of the dataset, event lists can be created. For that purpose, the IED is typically synchronized with accuracy in the order of 1 ms.

Applications

A typical application of SCADA is the creation of alarm lists and event lists. Today, the data content of the alarm lists and event lists is specified through signal lists. With IEC 61850, datasets used together with the report service can be used for that purpose. As an example, a utility may specify a dataset per IED that contains all data for the alarm list.

The NCC gateway provides the interface from the NCC to the substation. It has two basic tasks:

- Protocol and data conversion
- Data collection

For the data collection, the NCC gateway is a client in the IEC 61850 based substation automation system. The data is typically collected using the report model. The dataset used in that case corresponds to the traditional signal list specifying the information from the substation to be transmitted to the NCC.

How to use IEC 61850 for time critical information exchange

Task

There are several automated functions in the substation automation system, which require a time critical exchange of binary ●●●

information between functions located within the same bay or in different bays. Examples:

- Exchange between line protection and autorecloser
- Exchange between bays for breaker failure
- Exchange between bays for station interlocking

Typically, these functions are not using human interaction and are time critical. They are time critical because they are safety critical. The maximal accepted communication delay is in the range of several milliseconds [7].

If the functions exchanging the information are located in different IED's, the information exchange may be done using copper wiring with contacts and auxiliary relays or using serial communication. This information exchange is a horizontal communication between devices at the same hierarchical level (Figure 3).

Theoretically, the information exchange could take place using the client-server communication. However, client-server communication is using the full seven-layer stack and is therefore relatively time consuming. An appropriate communication concept used is a publisher-subscriber communication. The publisher is distributing the information over the communication network; the subscriber may receive the information according his needs. In IEC 61850 publisher-subscriber communication is not using confirmed services and is therefore transmitted over a reduced communication stack resulting in a very short transmission time.

Model

The concept of logical nodes has been introduced in clause 2.2. As an example, for the information exchange between the *protection function* and the *breaker failure function*, the following logical nodes are involved:

- **PTRC (Protection Trip Conditioning)** representing the logic in a protection device that creates the binary outputs (start and trip output of e.g. the line protection device)
- **RBRF** representing the protection **R**elated function **B**reaker **F**ailure function

The information exchange between these logical nodes is also modeled as data. The data is part of the logical node that is the source of the information exchange. As an example, the logical node PTRC has a data **Tr** with an attribute **general** representing the trip output of the protection device for a general trip. That signal is not only used to operate the breaker, but it is used as well to trigger e.g. the breaker failure function (see Figure 4 and Figure 5).

For the exchange of this type of (binary) information over serial communication, IEC 61850 introduces a specific information exchange service called GOOSE (Generic Object Oriented Substation Event) based on the publisher-subscriber concept. The content of a GOOSE message is defined with a dataset (similar like for the report model described above). The GOOSE message is sent as a multicast message over the communication network. That means that multiple devices can receive the message and retrieve the information required from the message. The communication service is not confirmed; instead, the message is repeated several times.

In the example of the breaker failure function a GOOSE message is configured in the protection device that contains at least the data attribute **PTRC.Tr.general**. As soon as **PTRC.Tr.general** changes its value to TRUE, the GOOSE message is sent. The device performing the breaker failure function is receiving this message and detects that **PTRC.Tr.general** has changed its value to TRUE. Another GOOSE message is sent when the value changes back to FALSE. ●●●

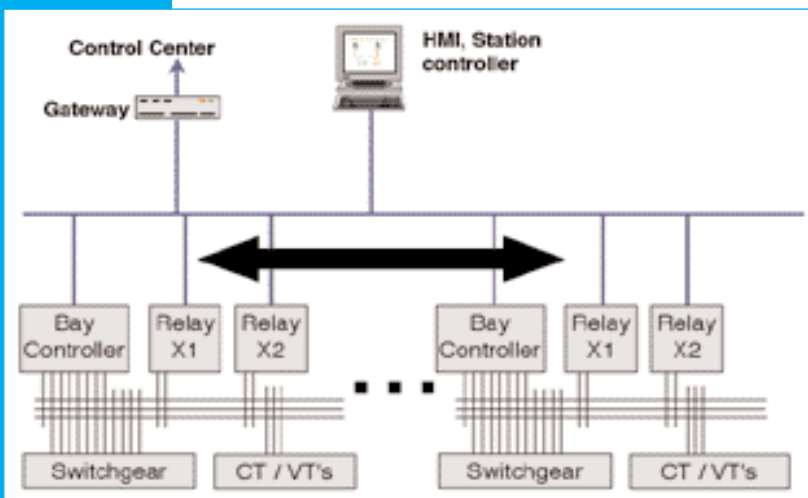

Figure 3: Horizontal communication in the substation automation system with hardwired process interface

Applications

Basically, there are two types of application, depending if the exchange of information is between devices inside the bay or between devices placed in different bays.

Exchange of information inside the bay: A typical example is the exchange of information between Logical Device "Distance Protection" containing instances of LN PDIS per zone and the LN PTRC (and the Logical Device "Recloser" containing the LN RREC (, in case these both functions are installed in separate devices (Figure 4).

The LD "Distance Protection" sends information to the LD "Recloser": start of starting elements in LN PTRC (PTRC.Str) and trip in LN PTRC (PTRC.Op). Based on these information and depending on the settings (single pole recloser or three pole recloser; RREC.TrMod) the recloser function represented by RREC will send information (RREC.TrBeh) to the LD "Distance Protection" in order to enable the expected trip (if one or three phases PTRC.Tr) to the breaker. The open command to the breaker is issued by the recloser function (RREC.Op).

Exchange of information between bays:

The information exchange between *protection device* and *breaker failure* used to start

the breaker failure function has already been used as example to explain the model in the clause 3.2. In case the concerned breaker does not open, the breaker failure function may retrip (RBRF.OpIn) and, without success send a trip to all surrounding breakers. This is modeled with the data RBRF.OpEx.

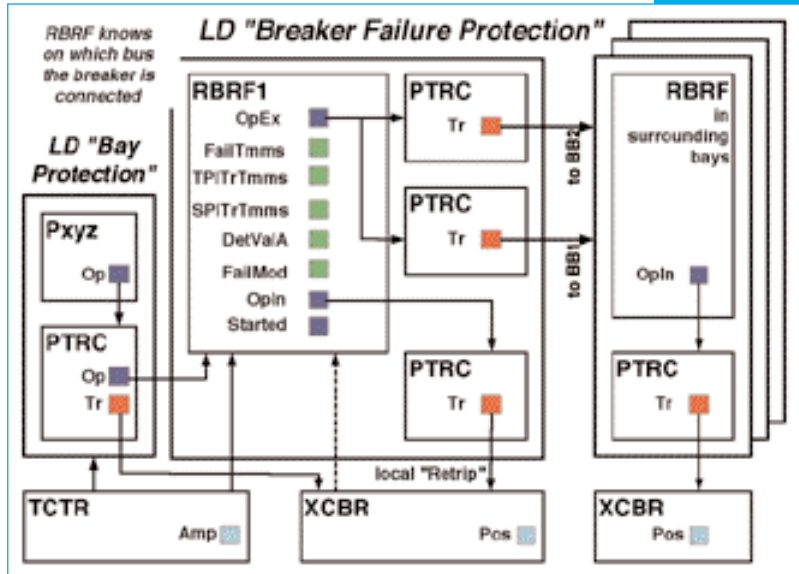

Figure 5: Breaker failure protection in double busbar arrangement

In Figure 5, the modeling of the breaker failure function in a double bus arrangement is shown. The breaker failure protection is initiated by trip indications from the LD "Bay Protection" (PTRC.Op). The criterion for ●●●

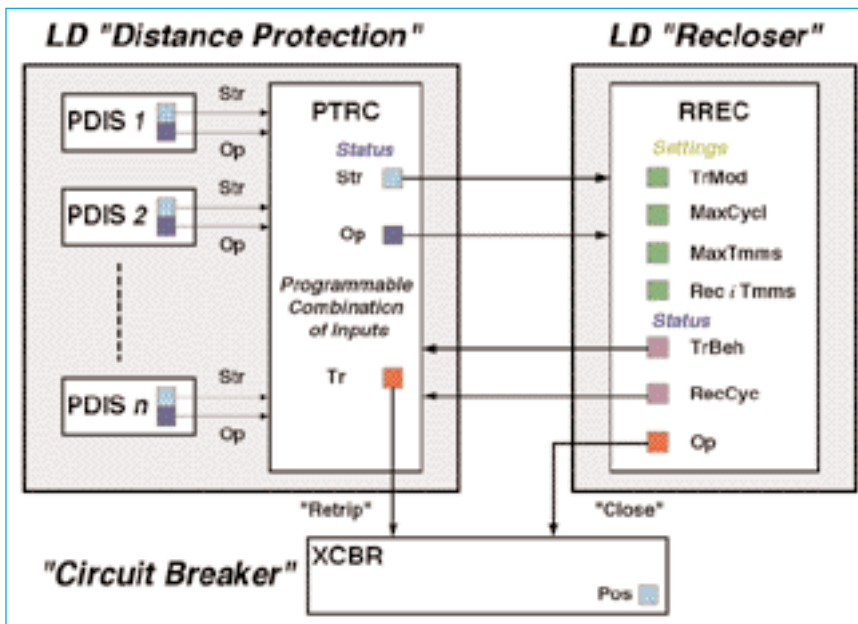

Figure 4: Connection between distance protection and recloser functions

breaker failure protection is typically the current (**RBRF.FailMod=current**) with the setting **RBRF.DetValA**. As first step the breaker failure function will issue a retrip to the circuit breaker (**RBRF.OpIn**) after a certain time delay (**RBRF.SPTrTmms** for single pole trip; **RBRF.TPTrmms** for three pole trip). If the breaker didn't open before the second time delay (**RBRF.FailTmms**) is elapsed, the breaker failure function will initiate an external trip (**RBRF.OpEx**). This external trip is forwarded according to the busbar image to the surrounding breakers. While in conventional technology this is implemented with two auxiliary relays, in IEC 61850 two instances of the LN **PTRC** are used to model this. A GOOSE message that contains the data **PTRC1.Op** and **PTRC2.Op** is distributed to all other bays.

How to use IEC 61850 for process connection

Task

The process connection provides the information exchange between the substation automation system and the high voltage equipment:

- Voltage and current waveforms
- Position and other status
- Open, close and other controls

The information exchange may be done using copper wiring (e.g. secondary nominal value of 100V/5A for voltage and current waveforms) or using serial communication (Figure 6).

For the exchange of voltage and current waveforms using standardized serial communication, IEC 61850 defines the service for sampled value transmission. All other information exchange is using either the client-server concept as described in clause 2 for SCADA application and the GOOSE message as described in clause 3 for the time critical communication like e.g. the transmission of a trip signal from the protection relay to the circuit breaker.

Model

The concept of logical nodes as functional grouping of information has been introduced in clause 2.2. There is a group of logical nodes that represents the data model of the high voltage equipment like

- XCBR representing a circuit breaker
- XSWI representing any other switching equipment
- TCTR representing a single phase current transformer
- TVTR representing a single phase voltage transformer.

The logical nodes XCBR and XSWI include the data **Pos** with an attribute **stVal** used to retrieve the position information and another one **ctVal** to execute open and close commands (Figure 2). Additional data is used to model further status information like e.g. the operation capability of a circuit breaker (energy stored in the drive; e.g. o-c-o). For SCADA applications, these logical nodes and their data are accessed using the client / server based communication.

The logical nodes TVTR and TCTR include the data **Vol** and **Amp**. These data represent the sampled value of the voltage and current waveform. For the exchange of voltage and current waveform over a serial communication, a stream of these sampled values needs to be transmitted.

An important aspect while using sampled values of a power system is the phase relationship between the different measured signals, in particular between current and voltage. IEC 61850 is using the concept of synchronized sampling. All units performing sampling are globally synchronized with the required accuracy. The samples are taken all at the ●●●

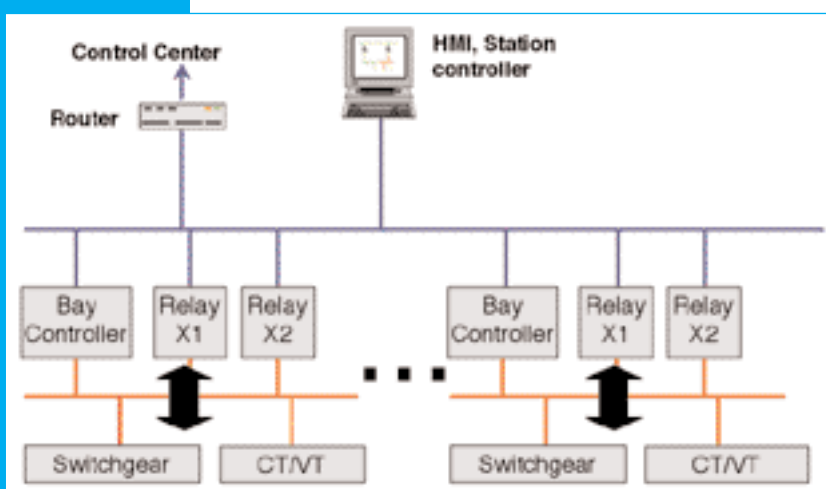

Figure 6: Process connection with serial communication

same time. Each sample is identified with a number that provides the time reference. That approach can deal with variable communication delays, as they are inevitable when using a network topology for the communication.

The message with the sampled values is typically transmitted as a multicast message – that means the same telegram can be received by multiple receiving devices. As for the GOSSE message the content of the message is defined with a dataset.

Applications

A typical application for the process connection is the information transfer between instrument transformers, protection devices and circuit breakers. This information transfer is time critical. It has a direct impact on the reaction time of the protection function. The acceptable transmission delay is in the range of 3 μ s [7].

The analog waveform of current and voltage is transmitted as a stream of samples as described in clause 4.2. In order to fulfill the requirements for the protection functions, the synchronization accuracy for the sampling needs to be in the range of 1...4 μ s (e.g. phase relationship of currents for differential protection, phase relationship between current and voltage for fault locator and distance protection). To achieve that synchronization accuracy, a dedicated synchronization network is currently required.

To simplify the synchronization of samples from all phases all relevant TCTRs and TVTRs may be implemented in a common Logical Device called Merging Unit (MU). One or many of these Logical Devices are implemented in a common Physical Device sometimes confusingly called MU also.

The samples are used as current and voltage input e.g. for protection. The trip from the protection device to the circuit breaker IED (**XCBR.pos.ctl**) can be transmitted over the same communication network using the GOOSE concept introduced in clause 3.2.

Another interesting example is the synchrocheck function. In case of reclosing (auto-

matal reclosure or manual switch on) a synchrocheck function is useful in order to check if both voltages (the one at line side and the one at bus side) are nearly identical (amplitude, phase frequency) allowing a switch on without excessive stress. The bus voltage is normally not available per bay but only once per bus zone on which the line will be connected. This bus zone voltage can be taken from the corresponding voltage transformer at the bus and introduced to the device where the synchrocheck function is placed. Using IEC 61850 the samples representing the bus voltage can be sent over the serial link to the synchrocheck function installed in the line bay where the reclosing should take place.

How to use IEC 61850 for substation automation design

Introduction to SCL

Substation automation design is a series of steps from the specification up to the commissioning of a project specific system. To show IEC 61850 is used in this process we have first to introduce shortly the Substation Configuration description Language (SCL) provided by the standard for this process. SCL was introduced for a comprehensive description of the complete SA system supporting the goal interoperability of the standard. SCL allows describing the

- single line diagram,
- function allocation to the single line diagram,
- function allocation to devices,
- data as being mandatory and optional according to IEC 61850 (optional if needed or provided),
- data as being extended according to the extension rules (should be avoided but may be needed),
- the services provided and used,
- connection in the communication system,
- setting of all configuration parameters as defined in IEC 61850,
- defaults values of for all operational parameters as defined in IEC 61850.

The SCL is based on the eXtended Markup Language (XML), known also from the description of Web pages, with an XML Schema defining the semantic use of XML in the ●●●

description of the substation and SA configuration. The goal of SCL is to have a formal description of the SA on engineering level, i.e. files, which can be exchanged between proprietary tools of different suppliers.

Specification by the user

In a first approach nothing looks changed in a specification for IEC 61850 compliant SA compared to previous specifications. The following elements are part of the specification:

- The single line diagram of the substation
- Signal lists and data flow requirements
- The specification of functionalities to be performed (including performance figures and availability requirements if applicable) and their allocation to the single line diagram
- The interfaces both to the switchgear (process interface) and to the NCC (protocol)
- The geographical layout (extension, buildings, cable channels, etc.)
- The environmental conditions

If not more is specified the supplier will translate the specification to an optimized solution based both on his experience and the framework of IEC 61850.

Since the data model of IEC 61850 is defined function oriented, i.e. according to the functional needs but not based on certain implementation in devices, a *function oriented specification* facilitates the translation to an IEC 61850 based SA system. All data defined as **mandatory** are provided according to the data model in IEC 61850. If the user needs data declared as **optional** this has to be specified. If data are needed which are not specified in the standard, they have to be listed for possible extensions.

The specification of functionality results basically in a selection of required logical nodes. Some aspects of the functionality requirements may have an impact on the services, e.g. there are different command services available ranging from a "direct control" to "select-before-operate (SBO) with enhanced security".

Availability figures or scenarios may be provided answering the questions about the accepted or not accepted impact of failures.

If these are not given, the system integrator has to make certain assumption to select the proper communication architecture out of the wide range of architectures possible with Ethernet used in IEC 61850.

The customer may specify also pre-qualified IEC 61850 compliant devices, e.g. different for main 1 and main 2 protection. This will limit the optimization process of the provider but may be of special interest to get similar SA systems after a successful operation of the first optimized system.

First considerations and recommendations for the specification of IEC 61850 based SA systems have been published in [12]. In addition the WG 11 of the CIGRE SC B5 is working out details to be used as guideline for utilities or other specifying parties.

Form of the specification

Using SCL, many of the above-described requirements can be formally specified in a System Specification Description file (SSD). If the customer does not yet do this it is left as task for the supplier.

The SSD file is used to describe the *single line diagram* and the *allocated functions* (feeder block diagram). The optional data that need to be supported can also be described in the SSD file. This replaces the traditional signal list, the elements of a signal list being the data of logical nodes. Up to now, the signal list is not only used to describe the complete information content, but also to describe the data flow. In IEC 61850, the data flow is implemented through communication services like report or GOOSE where the content is defined by data sets being a group of data.

The capabilities of an IEC 61850 compliant device (IED) are described in an IED Capability Description (ICD) file. A vendor of devices claiming conformance to IEC 61850 has not only to supply paper documentation like a data sheet but also an ICD file.

From specification to system design as task for the system integrator

The specification has to be translated by the provider to a system design (see e.g. ●●●

[14]). The responsibility for the system design, including the resulting performance, is the task of the system integrator. He has more responsibilities in the multi-vendor environment possible with IEC 61850. He has to consider not only the direct impact of IEC 61850 but also all boundary conditions regarding environment, performance, etc. as summarized in p.17. The system integrator may be part of the main provider or of the utility, but he has to have the know-how and experience for this job and, very important, powerful tools compliant with IEC 61850. Note that the standard is not defining tools but by SCL standardized information (see further) to be used by proprietary tools.

Any system integration tools needs the SSD file and the ICD files of all devices of the system. The output is the Substation Configuration Description (SCD) file. For maintenance and future system modifications the SCD files have to be archived as part of the project documentation.

Product and system engineering with compatible tools

Since the functions are not standardized, device specific tools will remain at least for the next time. They are depending mostly on the function algorithms and their implementation in the IEDs. If they are in series with the system configuration tool they have to be IEC 61850 compliant, i.e. to be able to export and import SCL files if applicable. The complete engineering process is schematically shown in Figure 7.

- The starting point of the engineering process (Figure 7) is the formal description of the single line diagram, and part of the data model by the SSD file.

- Any selected IED if IEC 61850 compliant has to have an IED Capability Description (ICD) file including its potential data model.

- A **system configuration tool** will take all these files written according to SCL and merge these by the system engineering process to a Substation Configuration Description (SCD) file.

- If the ICDs are properly selected, the data of all IEDs represented by the ICD files have to fit with the data in the SSD file. Since the data in the models represent only the source or client part, the data have to be configured in data sets for the transmission by the appropriate services (e.g. Report, GOOSE) and in so-called input sections of the SCL file, since the receiver side has to be informed where the data needed for the functions coming from.

- All data changes caused by the promotion of the IEDs from the shelf to integrated system components, i.e. in minimum some addressing information, have to be downloaded to the IEDs.

The formal SCL description will result in a consistent data exchange, allow exchanges between compliant tools independent from the supplier and, finally, in a machine-readable documentation of the data and communication structure of the SA system. Any extension or update in the future will not start from the scratch but from the archived SCD file. ●●●

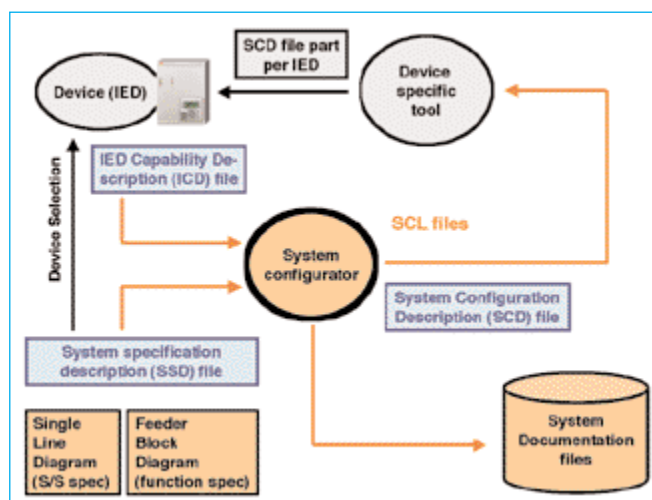

Figure 7: The engineering process using SCL files

How to USE IEC 61850 for testing and commissioning

Conformance testing

Devices are the physical (IED) building blocks of a system. To minimize problems with interoperability in a project, any IED to be integrated in an IEC 61850 based SA system should be IEC 61850 compliant by itself. The report of the CIGRE TF 34.01 [8] gives some general testing guidelines for communication in SA, Part 10 of IEC 61850 [9] provides a frame specification concerning conformance testing of devices including the mandatory ICD file. The goal is that testing in any test laboratory is done in comparable and universal valid way. The conformance test is depending on the device under test but independent of a real project. Note that the user group UCA International tries to detail the test to facilitate the procedure. The device and its content have to be the same as described by the mandatory ICD file.

System performance testing

To check the performance classes as defined in the mandatory part IEC 61850-5 for the device in a system (system conformance) independent from a project, the IEDs may be tested in a test system with reasonable data traffic in the background.

The Factory Acceptance Test

The factory acceptance test (FAT) has to prove that the SA system as far as assembled in one factory fulfills the given specification of the customer. The prerequisite is that all components are conformant with IEC 61850 and that the all SCL files used in engineering, especially the resulting SCD file is available. With some minor exceptions for systems on MV level, the switchgear will not be available for the FAT. The missing switchgear and other missing parts have to be simulated. For an IEC 61850 based system appropriate simulators having serial interfaces according to the standard can easily do this. If the system has also an IEC 61850 process bus simulators may be plugged in to the bus representing the switchgear. Quasi-standardized or project specific switchgear plugs are replaced by the standardized process bus interface. Note that also devices monitoring the tests

have to be equipped with IEC 61850 interfaces. The test of the functionality has to be done same as before.

Commissioning and Site Acceptance Test

The site acceptance test (SAT) has to prove the same as the FAT but now on site with the switchgear in the real substation environment. Conventional wiring requires mostly a conventional point-to-point test. In case of a process bus, the data consistency in the SA system from the NCC gateway down to the switchgear has been already proven in the engineering process with the resulting SCD file. The only mistake could be an allocation mismatch between the bay units and the process bus connectors plugged in. Only this check and outstanding function tests have to be performed. This speeds up the SAT dramatically.

How to use IEC 61850 during the life cycle

The primary equipment as a whole needs changing once every 30 – 60 years but may be extended during the life cycle time of the substation. One of the most important aspects during the life cycle time is the facility for extensions or the refurbishment of existing parts of the SA system. In this respect it is to be considered that the replacement of an IED may be needed because of maintenance reason (failure of the equipment) or because of needs for a performance upgrade. In most cases the new coming in IED is not identical with the previous one, additional engineering and testing works are needed.

With IEC 61850 the whole system description and data remain available as formally provided in the SCD file. This is part of the documentation the user has received with the system delivery and has to be updated for any change in the system e.g. change of the event list. Using this documentation and taking over data coming from new devices or from new functions to be introduced in the system, the system integrator can perform the required extensions much easier than in the past.

A practical issue is the extension of a new bay to an existing SA system, which is ●●●

not yet IEC 61850 compliant. In this case it is recommended to build the new bay according IEC 61850 in order to have the advantages set by the standard for the life cycle of a substation automation system. For this reasons extension scenarios are very important but generally individual per substation.

Note that all actual versions of the software, hardware (IED) and switchgear are available and readable from remote if the optional feature "name plate" is used. This nameplate is provided in Logical Nodes, Logical Devices, Physical Devices and as external nameplate for switchgear also.

Outlook and conclusions

The Standard IEC 61850 covers all aspects related to the communication inside substation. It supports important issues as the naming and the engineering capabilities but also conformity, testing, etc. It is a comprehensive approach for the conception of the substation automation and protection with serial communication. It doesn't mean that all delivered systems will have the same "quality" independently of the manufacturer because architecture remains free (architecture of the communication system as well as location of the different functionality) as well as the quality of each function involved (e.g. protection functions). The first experiences done by manufacturers and utilities have now to confirm if the expectations are fulfilled and if some extensions inside the standard will be needed.

Besides the mentioned maintenance of the standard for communication within substations, activities have been started or are envisaged to use IEC 61850 also outside the substation. Within IEC, there exists already working groups using the standard in wind power, hydro-power and distributed energy resources (DER). The feasibility of IEC 61850 for the link to the NCC has been proven, a harmonization between the data model of IEC 61850 and the CIM model on Network Level is in progress. New work items to use IEC 61850 for communication between both ends of a line protection (protection application) are in preparation. The IEC TC57 WG10 takes care to the common data model, the user group UCA

International promotes the standard and tries to support all users. The intended result is seamless communication architecture for utilities.

Since IEC 61850 has high impact on the investment and operation of power systems, the utilities will consider the standard very actively same as the suppliers.

References

- [1] IEC 60870-5-101 "Telecontrol equipment and systems - Part 5-101: Transmission protocols - Companion standard for basic telecontrol tasks"
- [2] IEC 60870-5-104 "Telecontrol equipment and systems - Part 5-104: Transmission protocols - Network access for IEC 60870-5-101 using standard transport profiles"
- [3] IEC 60870-5-103 "Telecontrol equipment and systems - Part 5-103: Transmission protocols - Companion standard for the informative interface of protection equipment"
- [4] IEC 61850 "Communication networks and systems in substations" (www.iec.ch)
- [5] IEC 61850-7-2 "Communication networks and systems in substations - Part 7-2: Basic communication structure for substation and feeder equipment - Abstract communication service interface (ACSI)"
- [6] IEC 61850-7-4 "Communication networks and systems in substations - Part 7-4: Basic communication structure for substation and feeder equipment - Compatible logical node classes and data classes"
- [7] IEC 61850-7-3 "Communication networks and systems in substations - Part 7-3: Basic communication structure for substation and feeder equipment - Common data classes"
- [8] IEC 61850-5 "Communication networks and systems in substations - Part 5: Communication requirements for functions and device models"
- [9] K.P. Brand et al., Conformance Testing Guidelines for Communication in Substations, Cigré Report 34-01 - Ref. No. 180, August 2002
- [10] IEC 61850-10 "Communication networks and systems in substations - Part 10: Conformance testing"
- [11] K.P.Brand, V.Lohmann, W.Wimmer "Substation Automation Handbook", UAC 2003, ISBN 3-85759-951-5, 2003 (www.uac.ch)
- [12] K.P.Brand, M.Janssen "The specification of IEC 61850 based Substation Automation Systems" Paper presented at the DistribuTECH 2005, January 25-27, San Diego
- [13] CIGRE SC B5, WG11 "The introduction of IEC 61850 and its impact on protection and automation within substations", work started in 2003, report to be scheduled for 2005/2006
- [14] K.P. Brand, C. Brunner, W. Wimmer "Design of IEC 61850 based Substation Automation Systems according to customer requirements", Paper B5-103 of the B5 Session at CIGRE Plenary Meeting, Paris, 2004, 8 pages ■