

ABB INDUSTRIAL DRIVES

ACS880-04 drive modules (200 to 710 kW, 250 to 700 hp)

Hardware manual



ACS880-04 drive modules (200 to 710 kW, 250 to 700 hp)

Hardware manual

Table of contents



1. Safety instructions



5. Mechanical installation



7. Electrical installation



12. Start-up



Table of contents

1 Safety instructions

Contents of this chapter.....	15
Safety messages.....	15
General safety in installation, start-up and maintenance.....	16
Electrical safety in installation, start-up and maintenance.....	18
Electrical safety precautions.....	18
Additional instructions and notes.....	19
Printed circuit boards.....	19
Grounding.....	20
General safety in operation.....	21
Additional instructions for permanent magnet motor drives.....	21
Safety in installation, start-up, maintenance.....	21
Safety in operation.....	22

2 Introduction to the manual

Contents of this chapter.....	23
Target audience.....	23
Categorization by frame size and option code.....	23
Quick installation, commissioning and operating flowchart.....	24
Terms and abbreviations.....	25
Related documents.....	27

3 Operation principle and hardware description

Contents of this chapter.....	29
Product overview.....	30
Layout.....	31
Standard drive module configuration with option +E208.....	31
Drive module for flat mounting (option +C173).....	33
Drive module with full power cabling panels (option +H381).....	34
Drive module without full-size output cable connection terminals (option +0H371) and IP20 shrouds (option +0B051).....	35
Drive module configuration with power cable connection terminals on the right-hand side of the drive module (option +H391).....	36
Control unit.....	37
Control panel.....	37
Overview of power and control connections.....	38
Type designation label.....	38
Type designation key.....	39
Basic code.....	39
Option codes.....	40

4 Guidelines for planning the mechanical installation

Contents of this chapter.....	43
Installation positions of the drive module.....	44



Planning the layout.....	45
Layout example, door closed.....	45
Layout example, door open (standard drive module configuration).....	46
Layout example, door open (option +H391).....	47
Layout example, door open (option +0B051).....	48
Bookshelf mounting (standard drive module configuration).....	49
Bookshelf mounting (option +0B051).....	50
Bookshelf mounting (option +H381).....	51
Flat mounting (option +C173).....	52
Flat mounting (option +C173 + 0B051).....	53
Free space requirements.....	54
Free space at the top of the drive module.....	54
Free space around the drive module.....	54
Free space below the drive module.....	54
Installation positions other than vertical.....	55
ABB air inlet and outlet kits.....	55



5 Mechanical installation

Contents of this chapter.....	57
Safety.....	58
Examining the installation site.....	58
Moving and unpacking the unit.....	59
Moving the drive module.....	59
Unpacking.....	59
Package drawings.....	60
Examining the delivery.....	64
Lifting the drive module.....	64
Installation alternatives.....	64
Standard drive module configuration (bookshelf mounting).....	65
Drive module configuration for flat mounting (option +C173).....	65
Optional input power cable connection terminals and ground busbar assembly (+H370).....	65
Drive module with full cabling panels (option +H381).....	66
Drive module without full-size output cable connection terminals (option +0H371) and IP20 shrouds (option +0B051).....	66
Drive module configuration with power cable connection terminals on the right-hand side of the drive module (option +H391).....	66
Drive module without wheeled pedestal (option +0H354).....	67
Attaching the drive module to a mounting plate or wall.....	67
Attaching the drive module to a mounting plate or wall (option +H391).....	67
Attaching the external control unit.....	67
Attaching the external control unit to a mounting plate or wall.....	68
Attaching the external control unit vertically on a DIN rail.....	68
Attaching the external control unit horizontally on a DIN rail.....	69
Alternatives for grounding the drive module.....	69
Installing the bottom grille for IP20 degree of protection.....	71

6 Guidelines for planning the electrical installation

Contents of this chapter.....	73
Limitation of liability.....	73
North America.....	73

Selecting the main supply disconnecting device.....	73
Selecting the main contactor.....	74
Examining the compatibility of the motor and drive.....	74
Protecting the motor insulation and bearings.....	74
Requirements tables.....	75
Requirements for ABB motors, $P_n < 100$ kW (134 hp).....	75
Requirements for ABB motors, $P_n \geq 100$ kW (134 hp).....	76
Requirements for non-ABB motors, $P_n < 100$ kW (134 hp).....	77
Requirements for non-ABB motors, $P_n \geq 100$ kW (134 hp).....	78
Abbreviations.....	78
Availability of du/dt filter and common mode filter by drive type.....	79
Additional requirements for explosion-safe (EX) motors.....	79
Additional requirements for ABB motors of types other than M2_, M3_, M4_, HX_ and AM_.....	79
Additional requirements for braking applications.....	79
Additional requirements for ABB high-output and IP23 motors.....	79
Additional requirements for non-ABB high-output and IP23 motors.....	79
Additional data for calculating the rise time and the peak line-to-line voltage.....	80
Additional note for sine filters.....	81
Selecting the power cables.....	81
General guidelines.....	81
Typical power cable sizes.....	82
Power cable types.....	82
Preferred power cable types.....	82
Alternate power cable types.....	82
Not allowed power cable types.....	83
Additional guidelines – North America.....	83
Metal conduit.....	84
Power cable shield.....	84
Grounding requirements.....	85
Additional grounding requirements – IEC.....	86
Additional grounding requirements – UL (NEC).....	86
Selecting the control cables.....	86
Shielding.....	86
Signals in separate cables.....	87
Signals that can be run in the same cable.....	87
Relay cable.....	87
Control panel to drive cable.....	87
PC tool cable.....	87
Routing the cables.....	87
General guidelines – IEC.....	87
General guidelines – North America.....	88
Continuous motor cable shield/conduit and metal enclosure for equipment on the motor cable.....	89
Separate control cable ducts.....	89
Protecting the drive, input power cable, motor and motor cable in short circuit situations and against thermal overload.....	90
Protecting the drive and the input power cable in short-circuits.....	90
Tested circuit breakers.....	90
Protecting the motor and motor cable in short-circuits.....	90
Protecting the motor cables against thermal overload.....	91
Protecting the motor against thermal overload.....	91



Protecting the motor against overload without thermal model or temperature sensors..... 91

Protecting the drive against ground faults..... 92

 Residual current device compatibility..... 92

Implementing a motor temperature sensor connection..... 92

 Connecting a motor temperature sensor to the drive through an option module. 93

Implementing the emergency stop function..... 94

Implementing the Safe torque off function..... 94

Implementing the functions provided by the FSO safety functions module..... 94

Implementing the functions provided by the FSPS-21 PROFIsafe safety functions module..... 94

Implementing the functions provided by the FSCS-21 CIP Safety™ functions module..... 95

Using power factor compensation capacitors with the drive..... 95

Using a safety switch between the drive and the motor..... 95

Implementing an ATEX-certified motor thermal protection..... 96

Implementing the power loss ride-through function..... 96

Controlling a contactor between drive and motor..... 97

Implementing a bypass connection..... 97

 Example bypass connection..... 98

 Switching the motor power supply from drive to direct-on-line..... 98

 Switching the motor power supply from direct-on-line to drive..... 99

Protecting the contacts of relay outputs..... 99

7 Electrical installation

Contents of this chapter.....101

Safety.....101

 Handling fiber optic cables.....101

Grounding the motor cable shield at the motor end.....102

Measuring the insulation.....102

 Measuring the insulation resistance of the drive.....102

 Measuring the insulation resistance of the input power cable.....102

 Measuring the insulation resistance of the motor and motor cable.....102

 Measuring the insulation resistance of the brake resistor circuit.....103

Grounding system compatibility check.....103

 Corner-grounded and midpoint-grounded 525...690 V delta systems.....104

Installing the EMC filter (option +E202).....104

Connecting the power cables.....105

 Power cable connection diagram.....105

 Preparing the cable ends and making 360° grounding at the cable entry.....106

 Power cable connection procedure.....107

 DC connection.....108

Removing the control panel holder from the external control unit.....108

Attaching the control cable clamp plate.....108

Connecting the external control unit to the drive module.....109

 Control unit connection cables.....109

 Routing the control unit cables into the drive module.....110

 Connections to the drive module.....110

 Connections to the control unit.....110

Connecting the control cables to the terminals of the external control unit..... 112

Connecting the control cables to the integrated control unit (option +P905)..... 113



Connecting the control cables to the integrated control unit (options +P905 and +0B051).....	114
Connecting a control panel.....	115
Panel bus (control of several units from one control panel).....	115
Connecting a PC.....	117
Installing option modules.....	118
Installing the FSO-xx safety functions module.....	118
Installing the FSPS-21 PROFIsafe safety functions module.....	119
Installing the FSCS-21 CIP Safety™ functions module.....	119
Installing I/O extension, fieldbus adapter and pulse encoder interface modules.....	119
Wiring the option modules.....	120

8 Control unit

Contents of this chapter.....	121
General.....	121
ZCU-14 layout.....	122
Default control connection diagram of the drive control unit (ZCU).....	123
Additional information on the connections.....	125
Connecting motor temperature sensors to the drive.....	125
Power supply for the control unit (XPOW).....	125
Digital interlock (DIIL).....	125
The XD2D connector.....	125
Safe torque off (XSTO).....	126
Safety functions module connection (X12).....	126
Connector data.....	127
ZCU ground isolation diagram.....	129

9 Installation example 1 - Bookshelf installation in a 600 mm enclosure

Contents of this chapter.....	131
Limitation of liability.....	131
North America.....	131
Required parts.....	132
Required tools.....	132
Overall flowchart of the installation process.....	132
Installing the drive module into the enclosure.....	133
Connecting the power cables and installing the shrouds.....	134
Installing the roof and door (Rittal parts).....	135
Installing the roof and door (ABB air filters and roof).....	136
Removing the protective covering from the drive module air outlet.....	137
Miscellaneous.....	137
Input power cable entry from top.....	137
Attaching the drive module to a mounting plate or wall.....	137

10 Installation example 2 - Bookshelf installation in a 400 mm enclosure

Contents of this chapter.....	139
Limitation of liability.....	139
North America.....	139
Required parts.....	140
Required tools.....	140
Overall flowchart of the installation process.....	141
Installing the mechanical accessories into the enclosure.....	141



Connecting the power cables.....142
 Power cable connection diagram.....142
 Power cable connection procedure.....143
 Installing the drive module into the enclosure.....145
 Installation procedure.....145
 Assembly drawing of installing the drive module to the enclosure (frame R10).....149
 Assembly drawing of installing the drive module to the enclosure (frame R11).....150
 Assembly drawing of installing the roof and door.....151
 Removing the protective covering from the drive module air outlet.....152
 Miscellaneous.....152
 Installations with input and motor cables of size 4 × 240 mm² per phase.....152
 Installing the rubber grommet.....152

11 Installation checklist

Contents of this chapter.....155
 Checklist.....155

12 Start-up

Contents of this chapter.....157
 Reforming the capacitors.....157
 Start-up procedure.....157

13 Fault tracing

Contents of this chapter.....159
 LEDs.....159
 Warning and fault messages.....159

14 Maintenance

Contents of this chapter.....161
 Maintenance intervals.....161
 Description of symbols.....161
 Recommended maintenance intervals after start-up.....162
 Cabinet.....163
 Cleaning the interior of the cabinet.....163
 Heatsink.....163
 Cleaning the interior of the heatsink.....163
 Fans.....165
 Replacing the circuit board compartment cooling fans.....165
 Replacing the main cooling fans.....166
 Replacing the standard drive module.....167
 Replacing the drive module with option +H381.....169
 Capacitors.....171
 Reforming the capacitors.....172
 Control panel.....172
 Control unit.....172
 Replacing the ZCU-14 control unit battery.....172
 Replacing the memory unit of ZCU-14.....173
 Replacing safety functions modules FSO-12 (option +Q973) and FSO-21 (option +Q972).....174



Functional safety components.....	174
15 Ordering information	
Contents of this chapter.....	175
Control panel.....	175
Brake choppers and resistors.....	176
Output (du/dt) filters.....	176
Sine filters.....	176
EMC filter ARFI-10.....	176
Cabinet ventilation.....	176
Air inlet kits.....	176
Air outlet kits.....	178
Cooling fans.....	179
FSO accessories kit.....	180
Control panel mounting platforms.....	180
Retrofit accessory kits.....	180
16 Technical data	
Contents of this chapter.....	181
Marine type-approved drives (option +C132).....	181
Electrical ratings.....	181
Output derating.....	183
When is derating necessary.....	183
Ambient temperature derating.....	184
Altitude derating.....	184
Deratings for special settings in the drive control program.....	185
High speed mode.....	187
Fuses (IEC).....	189
Calculating the short-circuit current of the installation.....	189
Calculation example.....	190
Fuses (UL).....	191
Circuit breakers.....	192
Dimensions, weights and free space requirements.....	193
Losses, cooling data and noise.....	195
Typical power cables.....	196
Terminal and entry data for the power cables.....	197
Units with optional cabling panels (+H381).....	197
Units without full-size output cable connection terminals (+OH371) and with a common mode filter (+E208).....	197
Terminal data for the control cables.....	197
Electrical power network specification.....	197
Motor connection data.....	197
Brake resistor data.....	198
du/dt and sine filters.....	198
DC connection data.....	199
Control panel type.....	199
Efficiency.....	199
Energy efficiency data (ecodesign).....	200
Protection classes.....	200
Ambient conditions.....	201
Storage conditions.....	202



Colors.....	202
Materials.....	202
Drive.....	202
Package materials for module products.....	202
Package materials for options, accessories and spare parts.....	203
Materials of manuals.....	203
Disposal.....	203
Applicable standards.....	203
Markings.....	204
EMC compliance (IEC/EN 61800-3).....	205
Definitions.....	205
Category C2.....	206
Category C3.....	206
Category C4.....	206
UL checklist.....	208
Disclaimers.....	208
Generic disclaimer.....	208
Cyber security disclaimer.....	209
Declarations of conformity.....	209

17 Dimension drawings

Contents of this chapter.....	211
R10 – Standard configuration.....	212
R10 with options +E208+H370+J414+P905.....	213
R10 with options +0B051+C173+E208+H356+0H354+0H371.....	214
R10 with options +0B051+E208+H356+0H371.....	215
R10 with options +E208+H356+H381+J414+P905.....	216
R10 – Cabling panels (+H381) installed into a Rittal VX25 enclosure.....	217
R10 with options +E208+H370+H391+0J400.....	218
R11 – Standard configuration.....	219
R11 with options +E208+H370+J414+P905.....	220
R11 with options +0B051+E208+H356+0H371.....	221
R11 with options +E208+H356+H381+J414+P905.....	222
R11 with options +0B051+C173+E208+H356+0H354+0H371.....	223
R11 – Cabling panels (+H381) installed into a Rittal VX25 enclosure.....	224
Bottom plate for option +H381 in Rittal VX25 400 mm wide enclosure installation.....	225
Frame R11 with options +E208+H370+H391+0J400.....	226
Air baffles for the standard drive module and option +C173.....	227
Air baffles for option +H381 in Rittal VX25 400 mm wide enclosure installation.....	228
Material of the air baffles.....	228
External control unit.....	229

18 Example circuit diagram

Contents of this chapter.....	231
Example circuit diagram.....	231

19 The Safe torque off function

Contents of this chapter.....	233
Description.....	233
Compliance with the European Machinery Directive and the UK Supply of Machinery (Safety) Regulations.....	234



Wiring.....	235
Activation switch.....	235
Cable types and lengths.....	235
Grounding of protective shields.....	235
Single drive (internal power supply).....	236
Dual-channel connection.....	236
Single-channel connection.....	237
Multiple drives.....	238
Internal power supply.....	238
External power supply.....	239
Operation principle.....	240
Start-up including validation test.....	241
Competence.....	241
Validation test reports.....	241
Validation test procedure.....	241
Use.....	243
Maintenance.....	244
Competence.....	244
Perfect proof test procedure.....	245
Simplified proof test procedure.....	245
Fault tracing.....	246
Safety data.....	247
Terms and abbreviations.....	249
TÜV certificate.....	250

20 Resistor braking

Contents of this chapter.....	251
When to use resistor braking.....	251
Operation principle and hardware description.....	251
Planning the braking system.....	251
Generic guidelines.....	251
Resistor cables.....	252
Resistor thermal switch.....	252
Protecting the system against thermal overload.....	252
EMC compliance of the complete installation.....	253
Selecting the installation location for the brake resistors.....	253
Protecting the system in fault situations.....	253
Selecting the drive, brake chopper and brake resistor.....	253
Calculation example.....	254
Selecting a custom brake resistor.....	254
Mechanical installation of resistors.....	255
Electrical installation.....	255
Measuring the insulation of the assembly.....	255
Connection diagram.....	255
Connection procedure.....	255
Start-up.....	255
Parameter settings.....	255
Technical data.....	257
Ratings.....	257
SAFUR resistor data.....	257
Terminals and cable entry data.....	258

21 Filters

Contents of this chapter.....	259
<i>du/dt</i> filters.....	259
When is a <i>du/dt</i> filter necessary?.....	259
Selection table.....	259
Ordering codes.....	260
Description, installation and technical data of the FOCH filters.....	260
Sine filters.....	260
When is a sine filter necessary?.....	260
Selection table.....	260
Ordering codes.....	260
Derating.....	260
Description, installation and technical data of the sine filters.....	260

22 Step-by-step drawings for an installation example of standard drive configuration with option +E208 in Rittal VX25 600 mm wide enclosure

Step-by-step drawings for installation example 2 - Bookshelf installation (option +H381) in a Rittal VX25 400 mm enclosure

Installation procedure.....	266
Installation procedure (continued).....	267

23 Step-by-step drawings for a flat installation example in a Rittal VX25 600 mm wide enclosure

24 Step-by-step drawings for option +H391 installation example in a Rittal VX25 600 mm wide enclosure

Further information



1

Safety instructions

Contents of this chapter

This chapter contains the safety instructions which you must obey when you install, start-up, operate and do maintenance work on the drive. If you ignore the safety instructions, injury, death or damage can occur.

Safety messages

These safety messages help to prevent personal injury and damage to the equipment. The hazard levels comply with standard ANSI Z535.6.

The manual uses these warning symbols:



▲DANGER Indicates a hazardous situation which, if not avoided, will result in death or serious injury.



▲WARNING Indicates a hazardous situation which, if not avoided, could result in death or serious injury.



▲CAUTION Indicates a hazardous situation which, if not avoided, could result in minor or moderate injury.

NOTICE Is used to address practices not related to physical injury, but which can result in equipment damage.



General safety in installation, start-up and maintenance

These instructions are for all persons who do work on the drive.



WARNING Obey these instructions. If you ignore them, injury or death, or damage to the equipment can occur.

- Keep the drive in its package until you install it. After unpacking, protect the drive from dust, debris and moisture.
- Use the required personal protective equipment: safety shoes with metal toe cap, safety glasses, protective gloves and long sleeves, etc. Some parts have sharp edges.
- Use a lifting device to lift a heavy drive. Use the designated lifting points. Refer to the dimension drawings.
- Obey the local laws and regulations that apply to lifts, such as the requirements to plan the lift, the capacity and condition of the lifting equipment, and personnel training.
- Attach the drive cabinet to the floor to prevent it from falling over. The cabinet has a high center of gravity. When you pull out heavy components or power modules, there is a risk of overturning. Attach the cabinet also to the wall when necessary.

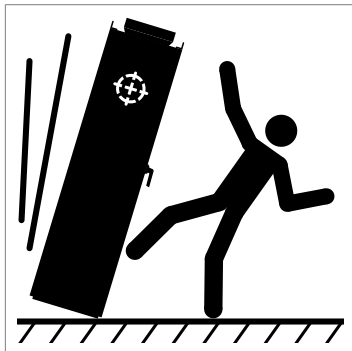

- Beware of hot surfaces. Some parts, such as heatsinks of power semiconductors, and brake resistors, can be hot for a period after operation.
- Before the start-up, vacuum clean the area around the drive to prevent the drive cooling fan from drawing dust inside the drive.
- Make sure that debris from drilling, cutting and grinding does not go into the drive during installation. Electrically conductive debris inside the drive can cause damage or malfunction.
- Make sure that there is sufficient cooling. Refer to the technical data.
- Keep the drive cabinet doors closed when the drive has electrical power. If the doors of the drive cabinet are open, there is a risk of a potentially fatal electric shock, arc flash or high-energy arc blast exists.
- If you must do work on a drive that is connected to the power supply, obey the local laws and regulations on live electrical work. This includes, but is not limited to, electric shock and arc protection.
- Before you adjust the drive operation limits, make sure that the motor and all driven equipment can operate throughout the set operation limits.

- Before you activate the automatic fault reset or automatic restart functions of the drive control program, make sure that no dangerous situations can occur. These functions reset the drive automatically and continue operation after a fault or break in the power supply. If these functions are activated, the installation must be clearly marked as defined in IEC/EN/UL 61800-5-1, subclause 6.5.3, for example, "THIS MACHINE STARTS AUTOMATICALLY".
- The maximum number of drive power-ups is five in ten minutes. Too frequent power-ups can damage the charging circuit of the DC capacitors.
- If the drive has connected safety circuits (for example, Safe torque off or emergency stop), validate them at start-up. Refer to separate instructions for the safety circuits.
- Beware of hot air flow from the cooling outlets.
- Do not cover the air inlet or air outlet when the drive operates.

Note:

- If you select an external source for the start command and it is on, the drive starts immediately after a fault reset unless you configure the drive for pulse start. Refer to the firmware manual.
- If the drive is in remote control mode, you cannot stop or start the drive with the control panel.
- Only authorized persons are permitted to repair a faulty drive.



Electrical safety in installation, start-up and maintenance

■ Electrical safety precautions

These electrical safety precautions are for all persons who do work on the drive, motor cable or motor.



▲ WARNING Obey these instructions. If you ignore them, injury or death, or damage to the equipment can occur. If you are not a qualified electrical professional, do not do electrical installation or maintenance work. Do these steps before you do installation or maintenance work.

1. Prepare for the work.
 - Make sure that you have a work order.
 - Do an on-site risk assessment or job hazard analysis.
 - Make sure that you have the correct tools available.
 - Make sure that the workers are qualified.
 - Select the correct personal protective equipment (PPE).
 - Stop the drive and motor(s).
2. Clearly identify the work location and equipment.
3. Disconnect all possible voltage sources. Make sure that connection is not possible. Lock out and tag out.
 - Open the main disconnecting device of the drive.
 - Open the charging switch if it is present.
 - Open the disconnecter of the supply transformer. (The main disconnecting device in the drive cabinet does not disconnect the voltage from the AC input power busbars of the drive cabinet.)
 - Open the auxiliary voltage switch-disconnector (if it is present), and all other possible disconnecting devices that isolate the drive from dangerous voltage sources.
 - If there is a permanent magnet motor connected to the drive, disconnect the motor from the drive with a safety switch or by other means.
 - Open the main isolating device of the drive.
 - Disconnect all dangerous external voltages from the control circuits.
 - After you disconnect power from the drive, wait 5 minutes to let the intermediate circuit capacitors discharge before you continue.
4. Protect other energized parts in the work location against contact and take special precautions when close to bare conductors.
5. Measure that the installation is de-energized. Use a high-quality voltage tester. If the measurement requires that you remove shrouding or other cabinet structures, obey the local laws and regulations applicable to live electrical work. This includes, but is not limited to, electric shock and arc protection.
 - Before and after you measure the installation, verify the operation of the voltage tester on a known voltage source.
 - Make sure that the voltage between the input power terminals of the drive (L1, L2, L3) and the grounding (PE) busbar is zero.
 - Make sure that the voltage between the output power terminals of the drive (U, V, W) and the grounding (PE) busbar is zero.

Important! Repeat the measurement with the DC voltage setting of the voltage tester. Measure between each phase and ground. There is a risk of dangerous DC voltage charging due to leakage capacitances of the motor circuit. This



- voltage can remain charged for a long time after the drive power-off. The measurement discharges the voltage.
 - Make sure that the voltage between the drive DC terminals (UDC+ and UDC-) and the grounding (PE) terminal is zero.
6. Install temporary grounding as required by the local regulations.
 7. Ask for a permit to work from the person that is responsible for the electrical installation work.

■ Additional instructions and notes



▲WARNING Obey these instructions. If you ignore them, injury or death, or damage to the equipment can occur.

If you are not a qualified electrical professional, do not do installation or maintenance work.

- Keep the cabinet doors closed when the drive has electrical power. If the doors of the drive cabinet are open, there is a risk of a potentially fatal electric shock, arc flash or high-energy arc blast.
- Make sure that the electrical power network, motor/generator, and environmental conditions agree with the drive data.
- Do not do insulation or voltage withstand tests on the drive.
- If you have a cardiac pacemaker or other electronic medical device, do not go near the motor, drive, or the drive power cabling when the drive is in operation. The equipment produces electromagnetic fields that can cause interference in electronic medical devices. This can cause a health hazard.
- Remove the code labels that are attached to mechanical parts such as busbars, shrouds and sheet metal parts before installation. They can cause bad electrical connections, or, after peeling off and collecting dust, can cause arcing or block the cooling air flow.

Note:

- When the drive is connected to the input power, the motor cable terminals and the DC bus are at a dangerous voltage.
The brake circuit, including the brake chopper (option +D150) and brake resistor (if it is installed) are also at a dangerous voltage.
After you disconnect the drive from the input power, these remain at a dangerous voltage until the intermediate circuit capacitors discharge.
- External wiring can supply dangerous voltages to the relay outputs of the control units of the drive.
- The Safe torque off function does not remove the voltage from the main and auxiliary circuits. The function is not effective against deliberate sabotage or misuse.

Printed circuit boards

NOTICE Use an antistatic wrist strap when you handle printed circuit boards. Do not touch the boards unnecessarily. The boards are sensitive to electrostatic discharge.



■ Grounding

These instructions are for all persons who are responsible for the grounding of the drive.



⚠ WARNING Obey these instructions. If you ignore them, injury or death, or equipment malfunction can occur, and electromagnetic interference can increase.

If you are not a qualified electrical professional, do not do grounding work.

- Always ground the drive, the motor and adjoining equipment. This is necessary for personnel safety.
- Make sure that the conductivity of the protective earth (PE) conductors is sufficient and that other requirements are met. Refer to the electrical planning instructions of the drive. Obey the applicable national and local regulations.
- When you use shielded cables, make a 360° grounding of the cable shields at the cable entries to reduce electromagnetic emission and interference.
- In a multiple-drive installation, connect each drive separately to the protective earth (PE) busbar of the power supply.



General safety in operation

These instructions are for all persons that operate the drive.



▲WARNING Obey these instructions. If you ignore them, injury or death, or damage to the equipment can occur.

- Keep the cabinet doors closed when the drive has electrical power. If the doors of the drive cabinet are open, there is a risk of a potentially fatal electric shock, arc flash or high-energy arc blast.
- If you have a cardiac pacemaker or other electronic medical device, do not go near the motor, drive, or the drive power cabling when the drive is in operation. The equipment produces electromagnetic fields that can cause interference in electronic medical devices. This can cause a health hazard.
- Give a stop command to the drive before you reset a fault. If you have an external source for the start command and the start is on, the drive starts immediately after the fault reset, unless you configure the drive for pulse start. Refer to the firmware manual.
- Before you activate the automatic fault reset or automatic restart functions of the drive control program, make sure that no dangerous situations can occur. These functions reset the drive automatically and continue operation after a fault or break in the power supply. If these functions are activated, the installation must be clearly marked as defined in IEC/EN/UL 61800-5-1, subclause 6.5.3, for example, "THIS MACHINE STARTS AUTOMATICALLY".

Note:

- The maximum number of drive power-ups is five in ten minutes. Too frequent power-ups can damage the charging circuit of the DC capacitors. If you need to start or stop the drive, use the control panel keys or commands through the I/O terminals of the drive or the fieldbus interface.
- If the drive is in remote control mode, you cannot stop or start the drive with the control panel.

Additional instructions for permanent magnet motor drives

■ Safety in installation, start-up, maintenance

These are additional warnings for permanent magnet motor drives. The other safety instructions in this chapter are also valid.



▲WARNING Obey these instructions. If you ignore them, injury or death, or damage to the equipment can occur.

If you are not a qualified electrical professional, do not do installation or maintenance work.

- Do not do work on the drive when a rotating permanent magnet motor is connected to it. A rotating permanent magnet motor energizes the drive including its input and output power terminals.

Before installation, start-up and maintenance work on the drive:

- Stop the drive.
- Disconnect the motor from the drive with a safety switch or by other means.
- If you cannot disconnect the motor, make sure that the motor cannot rotate during work. Make sure that no other system, like hydraulic crawling drives, can rotate the motor directly or through any mechanical connection such as belt, nip, rope, etc.
- Do the steps in section [Electrical safety precautions \(page 18\)](#).
- Install temporary grounding to the drive output terminals (T1/U, T2/V, T3/W). Connect the output terminals together as well as to the PE.

During the start-up:

- Make sure that the motor cannot run at overspeed, for example, when it is driven by the load. Motor overspeed causes an overvoltage that can cause damage to the capacitors in the intermediate circuit of the drive.

■ Safety in operation



NOTICE Make sure that the motor cannot run at overspeed, for example, when it is driven by the load. Motor overspeed causes an overvoltage that can cause damage to the capacitors in the intermediate circuit of the drive.



Introduction to the manual

Contents of this chapter

This chapter describes the intended audience and contents of the manual. It contains a flowchart of steps in examining the delivery, installing and commissioning the drive. The flowchart refers to chapters/sections in this manual and in other manuals.

Target audience

This manual is intended for people who plan the installation, install, commission, and do maintenance work on the drive, or create instructions for the end user of the drive concerning the installation and maintenance of the drive.







Read the manual before you do work on the drive. You are expected to know the fundamentals of electricity, wiring, electrical components, and electrical schematic symbols.

Categorization by frame size and option code

The frame size identifies information which concerns only a certain frame size of the drive. The frame size is shown on the type designation label. All frame sizes are listed in the technical data.

The option code (A123) identifies information which concerns only a certain optional selection. The options included in the drive are listed on the type designation label.

Quick installation, commissioning and operating flowchart

Task	See
<p>Plan the mechanical and electrical installation and acquire the accessories needed (cables, fuses, etc.).</p> <p>Examine the ambient conditions, ratings, required cooling air flow, input power connection, compatibility of the motor, motor connection, and other technical data.</p>	<p>Guidelines for planning the mechanical installation (page 43)</p> <p>Guidelines for planning the electrical installation (page 73)</p> <p>Technical data (page 181)</p> <p>Resistor braking (page 251)</p> <p>Option manual (if optional equipment is included)</p>
	
<p>Unpack and examine the units.</p> <p>Make sure that all necessary optional modules and equipment are present and correct.</p> <p>Only intact units can be started up.</p>	<p>Moving and unpacking the unit (page 59)</p> <p>Examining the installation site (page 58)</p> <p>if the drive has not been powered (either in storage or unused) for a year or more, the converter DC link capacitors need to be reformed. (Reforming the capacitors (page 172))</p>
	
<p>Examine the installation site. Attach the base of the cabinet to the floor.</p>	<p>Examining the installation site (page 58)</p> <p>Ambient conditions (page 201)</p>
	
<p>Route the cables.</p>	<p>Routing the cables (page 87)</p>
	
<p>Measure the insulation of the supply cable, the motor and the resistor cable and the resistor cable (if present).</p>	<p>Measuring the insulation (page 102)</p>
	
<p>Standard drive modules</p> <ul style="list-style-type: none"> • Install the additional components into the cabinet: eg, main disconnector, main contactor, main AC fuses, etc. • Install the drive module into the cabinet • Connect the motor cables to the drive module terminals • Connect the brake resistors and DC connection cables (if any) to the drive module terminals • If the main disconnector is installed into the cabinet, connect it to the drive module terminals and the input power cabling to the disconnector • Connect the cables from the drive module to the external control unit and install the control unit into the cabinet. 	<p>Mechanical installation (page 57)</p> <p>Connecting the power cables (page 105)</p> <p>Connecting the external control unit to the drive module (page 109)</p> <p>Attaching the external control unit (page 67)</p> <p>Manuals for any optional equipment</p>
	

Task	See
<p><u>Drive modules with optional cabling panels (+H381)</u></p> <ul style="list-style-type: none"> • Install the cabling panels into the cabinet • Install the additional components into the cabinet: eg, main disconnect, main contactor, main AC fuses, etc. • If the main disconnect is installed into the cabinet, connect the input power cabling to it • Connect the input power cables and motor cables to the cabling panel terminals • Connect the brake resistors and DC connection cables (if any) to the cabling panel terminals • Install the drive module into the cabinet • Fasten the cabling panel busbars to the drive module busbars • <u>Drive modules with an external drive control unit:</u> Connect the cables from the drive module to the control unit and install the control unit into the cabinet. 	<p>Mechanical installation (page 57)</p> <p>Connecting the power cables (page 105)</p> <p>Installing the drive module into the enclosure (page 145)</p> <p>Connecting the external control unit to the drive module (page 109)</p> <p>Attaching the external control unit (page 67)</p> <p>Manuals for any optional equipment</p>
↓	
<p><u>Drive modules without full-size output cable connection terminals (option +0H371) and IP20 shrouds (option +0B051)</u></p> <ul style="list-style-type: none"> • Install the additional components into the cabinet: eg, main PE busbar, main disconnect, main contactor, main AC fuses, etc. • Install the drive module into the cabinet • Connect the power cabling between the drive module and the rest of the main circuit components in the cabinet (if any) • Connect the input power cables and motor cables to the drive cabinet • Connect the brake resistors and DC connection cables (if any) to the drive cabinet • <u>Drive modules with an external drive control unit:</u> Connect the cables from the drive module to the control unit and install the control unit into the cabinet. 	<p>Mechanical installation (page 57)</p> <p>Connecting the power cables (page 105)</p> <p>Installing the drive module into the enclosure (page 145)</p> <p>Connecting the external control unit to the drive module (page 109)</p> <p>Attaching the external control unit (page 67)</p> <p>Manuals for any optional equipment</p>
↓	
<p>Connect the external control cables to the drive control unit.</p>	<p>Connecting the control cables to the terminals of the external control unit (page 112)</p>
↓	
<p>Examine the installation.</p>	<p>Installation checklist (page 155)</p>
↓	
<p>Commission the drive.</p>	<p>Start-up (page 157)</p>
↓	
<p>Commission the brake chopper (if used).</p>	<p>Resistor braking (page 251)</p>
↓	
<p>Operate the drive: start, stop, speed control etc.</p>	<p>Appropriate firmware manual</p>

Terms and abbreviations

Term	Description
ACS-AP-I	Industrial assistant non-Bluetooth control panel
ACS-AP-W	Industrial assistant control panel with Bluetooth interface
BGDR	Gate driver board

Term	Description
DDCS	Distributed Drives Communication System. Optical fiber-based industrial protocol.
DTC	Direct torque control, a motor control method
EMC	Electromagnetic compatibility
EMI	Electromagnetic interference
FAIO-01	Analog I/O extension module
FCAN	Optional CANopen® adapter module
FCNA-01	Optional ControlNet™ adapter module
FDCO-01	DDCS communication module with two pairs of 10 Mbit/s DDCS channels
FDIO-01	Optional digital I/O extension module
FDNA-01	Optional DeviceNet™ adapter module
FEA-03	Optional I/O extension adapter
FECA-01	Optional EtherCAT® adapter module
FEIP-21	Optional Ethernet adapter module for EtherNet/IP™
FEN-01	Optional TTL incremental encoder interface module
FEN-11	Optional absolute encoder interface module
FEN-21	Optional resolver interface module
FEN-31	Optional HTL incremental encoder interface module
FENA-21	Optional Ethernet adapter module for EtherNet/IP™, Modbus TCP and PROFINET IO protocols, 2-port
FEPL-02	Optional Ethernet POWERLINK adapter module
FIO-01	Optional digital I/O extension module
FIO-11	Optional analog I/O extension module
FMBT-21	Optional Ethernet adapter module for Modbus TCP protocol
FPBA-01	Optional PROFIBUS DP® adapter module
FPNO-21	Optional PROFINET IO adapter module
FPTC-01	Optional thermistor protection module
FPTC-02	Optional ATEX-certified thermistor protection module for potentially explosive atmospheres
Frame, frame size	Physical size of the drive or power module
FSCA-01	Optional RS-485 (Modbus/RTU) adapter
FSCS-21	CIP Safety™ functions module
FSE-31	Optional pulse encoder interface module for safety encoder
FSO-12, FSO-21	Optional functional safety modules
FSPS-21	PROFIsafe safety functions module
HTL	High-threshold logic
IGBT	Insulated gate bipolar transistor
IT system	Type of supply network that has no (low-impedance) connection to ground. See IEC 60364-5.
PLC	Programmable logic controller
SAFUR	Series of brake resistors
SOIA	Optical interface adapter board
STO	Safe torque off (IEC/EN 61800-5-2)
TN system	Type of supply network that provides a direct connection to ground
TTL	Transistor-transistor logic
UCU	Type of control unit
ZBIB	Adapter board connected to the control board in the control unit
ZCU	Type of control unit
ZPOW	Power supply board

Related documents

You can find manuals and other product documents in PDF format on the Internet at www.abb.com/drives/documents and with the following code and link.



[ACS880-04 manuals](#)



3

Operation principle and hardware description

Contents of this chapter

This chapter describes the operation principle and construction of the drive module.

Product overview

The ACS880-04 is a drive module for controlling asynchronous AC induction motors, permanent magnet motors, AC induction servomotors and ABB synchronous reluctance motors (SynRM motors).

The main circuit of the drive module is shown below.

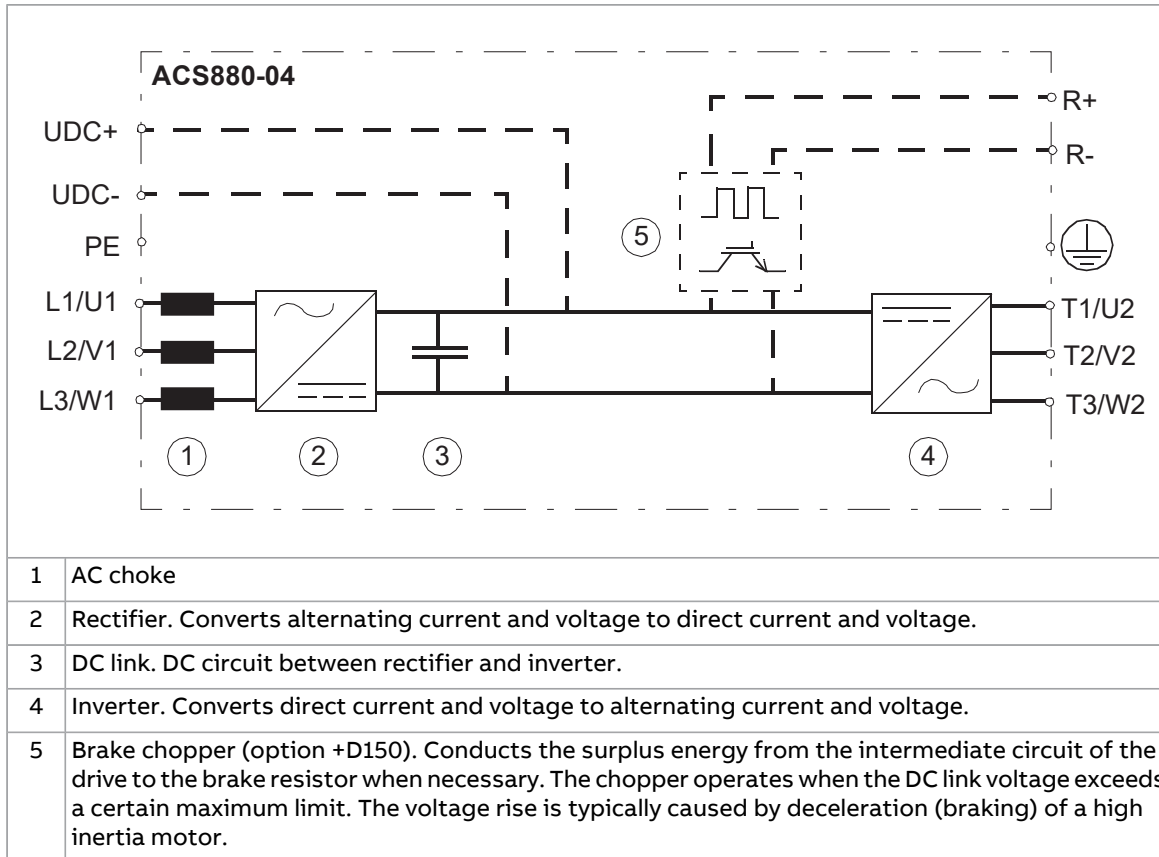

Layout

■ Standard drive module configuration with option +E208

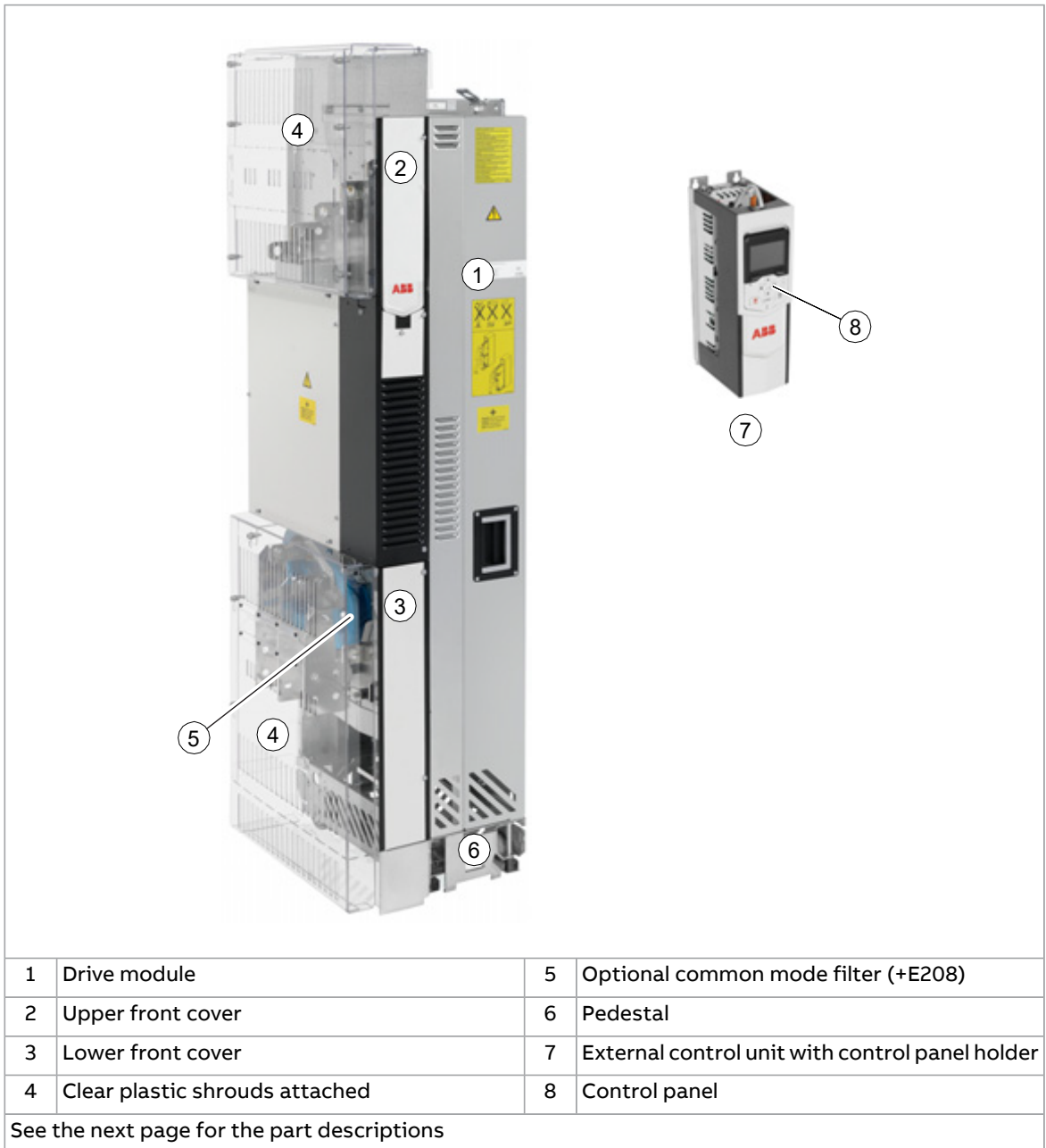

32 Operation principle and hardware description

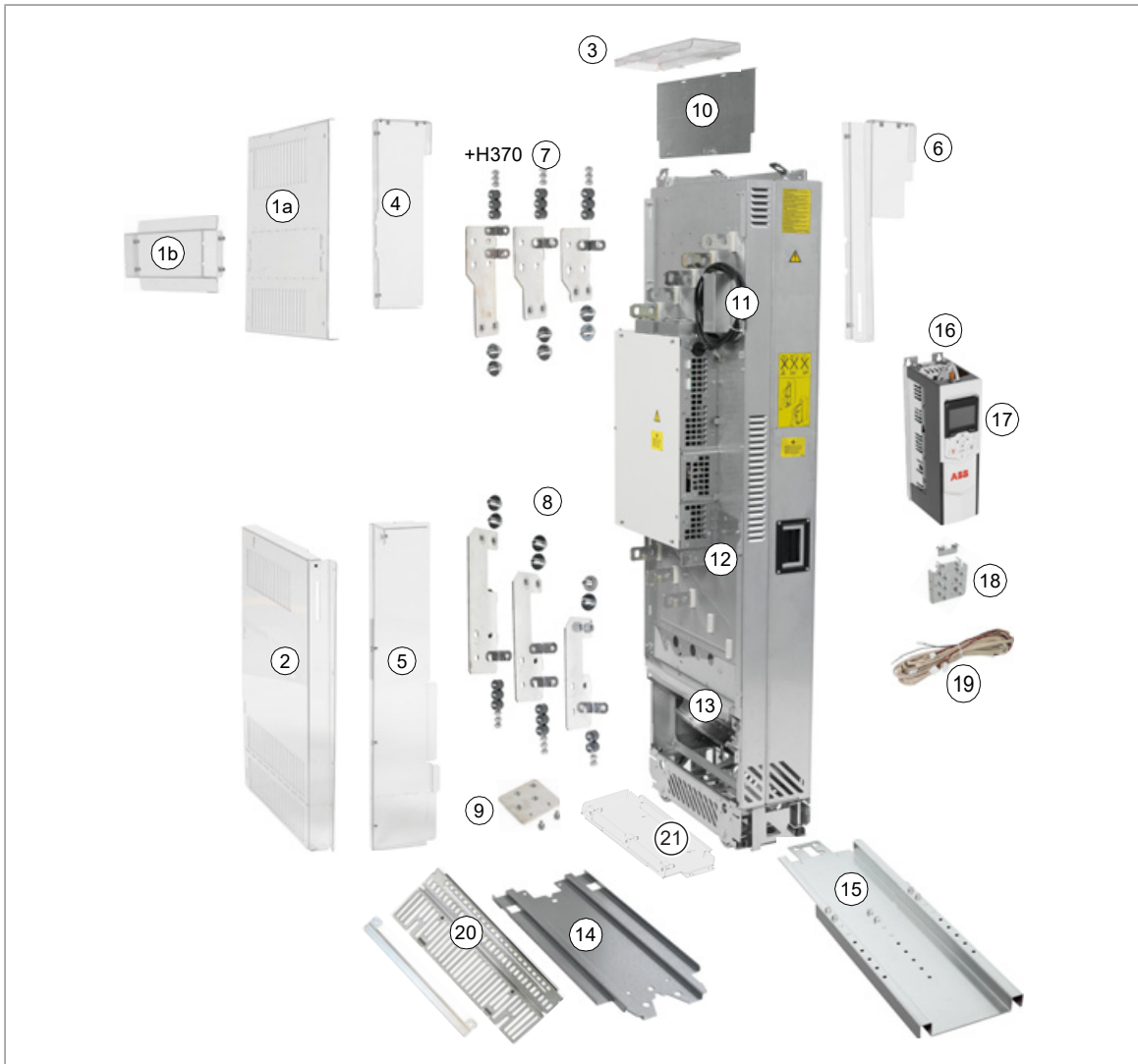

1	Clear plastic shroud to be attached onto the drive module input power cabling (a). Entry shroud for side cabling (b).	12	PE (ground) terminal
2	Clear plastic shrouds to be attached onto the drive module output power cabling	13	Main cooling fans
3	Clear plastic shroud to be attached on top of the drive module (entry for top cabling)	14	Pedestal guide plate
4	Upper back clear plastic shroud	15	Telescopic extraction/installation ramp
5	Lower back clear plastic shroud	16	External control unit. The control unit can also be inside the drive module (option +P905).
6	Front clear plastic shroud	17	Control panel
7	Input power cable connection terminals (option +H370)	18	Control cable clamp plate
8	Output power cable connection terminals	19	Cables for connecting the control unit to the drive module
9	Grounding terminal for output power cable shields	20	Bottom grille with mounting bracket
10	Metallic shroud. With option +H370, the shroud includes a ground bar.	21	Bottom clear plastic shroud
11	Fiber optic cables	-	-

■ **Drive module for flat mounting (option +C173)**

Front view of an assembled drive module for flat mounting is shown below. Option +C173 adds flat mounting brackets to the standard drive module configuration. Option +0H354 replaces the normal pedestal with a low pedestal. Option +0P919 removes the installation ramp. You must cut the lower part of the output cabling clear plastic shroud off when the low pedestal is in use.



Flat mounting position (front view)		Side view	
1	Flat mounting bracket (two pcs). The brackets are installed to the mounting plate with 2×8 screws. Four combi screws for installing the drive module to the brackets are included in the delivery.	4	Low pedestal
2	External control unit with control panel holder and control panel	5	Grounding terminal for output cabling
3	Bottom grille to be installed to the base of the drive module for IP20 degree of protection	6	Bottom clear plastic shroud with low pedestal

See section [Standard drive module configuration with option +E208 \(page 31\)](#) for the part descriptions.

■ Drive module with full power cabling panels (option +H381)



Accessories		Assembled drive module	
1	Input power cabling panel	8	Rubber grommet
2	Side guides	9	Input power cabling panel to be attached to the drive cabinet
3	Output power cabling panel	10	Output power cabling panel to be attached to the drive cabinet
4	Top guide plate	11	Front cover
5	Pedestal guide plate	12	Integrated control unit (option +P905) and control panel holder mounted on the drive module (option +J414)
6	Telescopic extraction/installation ramp	-	-
7	Shim plates for Rittal VX25 enclosure (8 pcs)	-	-

■ **Drive module without full-size output cable connection terminals (option +0H371) and IP20 shrouds (option +0B051)**



1	Lifting lugs
2	Fastening bracket
3	Input cable connection busbars (L1/U1, L2/V1, L3/W1) and DC+ and DC- busbars (UDC+, UCD with option +H356)
4	Circuit board compartment
5	Output cable connection busbars (T1/U2, T2/V2, T3/W2) and brake resistor connection busbars (R+ and R- with option +D150)
6	Control cable duct (not included with external control unit)
7	Main cooling fans
8	Pedestal
9	Retractable support legs
10	Base fastening screws
11	Handle for pulling the drive module out of the cabinet
12	Optional common mode filter (+E208)
13	PE busbar
14	Pedestal guide plate
15	Telescopic extraction/installation ramp

Note: The front covers are removed in this photo, see numbers 2 and 3 in section [Standard drive module configuration with option +E208 \(page 31\)](#).

■ **Drive module configuration with power cable connection terminals on the right-hand side of the drive module (option +H391)**



1	Lifting lugs
2	Fastening bracket
3	Input cable connection busbars (L1/U1, L2/V1, L3/W1) and DC+ and DC- busbars (UDC+, UCD with option +H356)
4	Circuit board compartment cooling fans
5	Circuit board compartment
6	Output cable connection busbars (T1/U2, T2/V2, T3/W2) and brake resistor connection busbars (R+ and R- with option +D150)
7	Main cooling fans
8	Pedestal
9	Retractable support legs
10	Base fastening screws
11	Handle for pulling the drive module out of the cabinet
12	PE busbar
13	Pedestal guide plate
14	Telescopic extraction/installation ramp
<p>Note: The front covers are removed in this photo, see number 11 in section Drive module with full power cabling panels (option +H381) (page 34).</p>	

■ **Control unit**

See section [Standard drive module configuration with option +E208](#) (page 31).

■ **Control panel**



In the standard drive module configuration, the control panel is located in the control panel holder of the external control unit.

When the control unit is inside the drive module (option +P905), the control panel can be mounted on the drive module (option +J414).

For the use of the control panel, see the firmware manual or [ACS-AP-I, -S, -W and ACH-AP-H, -W assistant control panels user's manual](#) (3AUA0000085685 [English]).

For the control panel mounting platforms, see [Cabinet design and construction instructions for drive modules](#) (3AUA0000107668 [English]).

Overview of power and control connections

The diagram shows the power connections and control interfaces of the drive module.

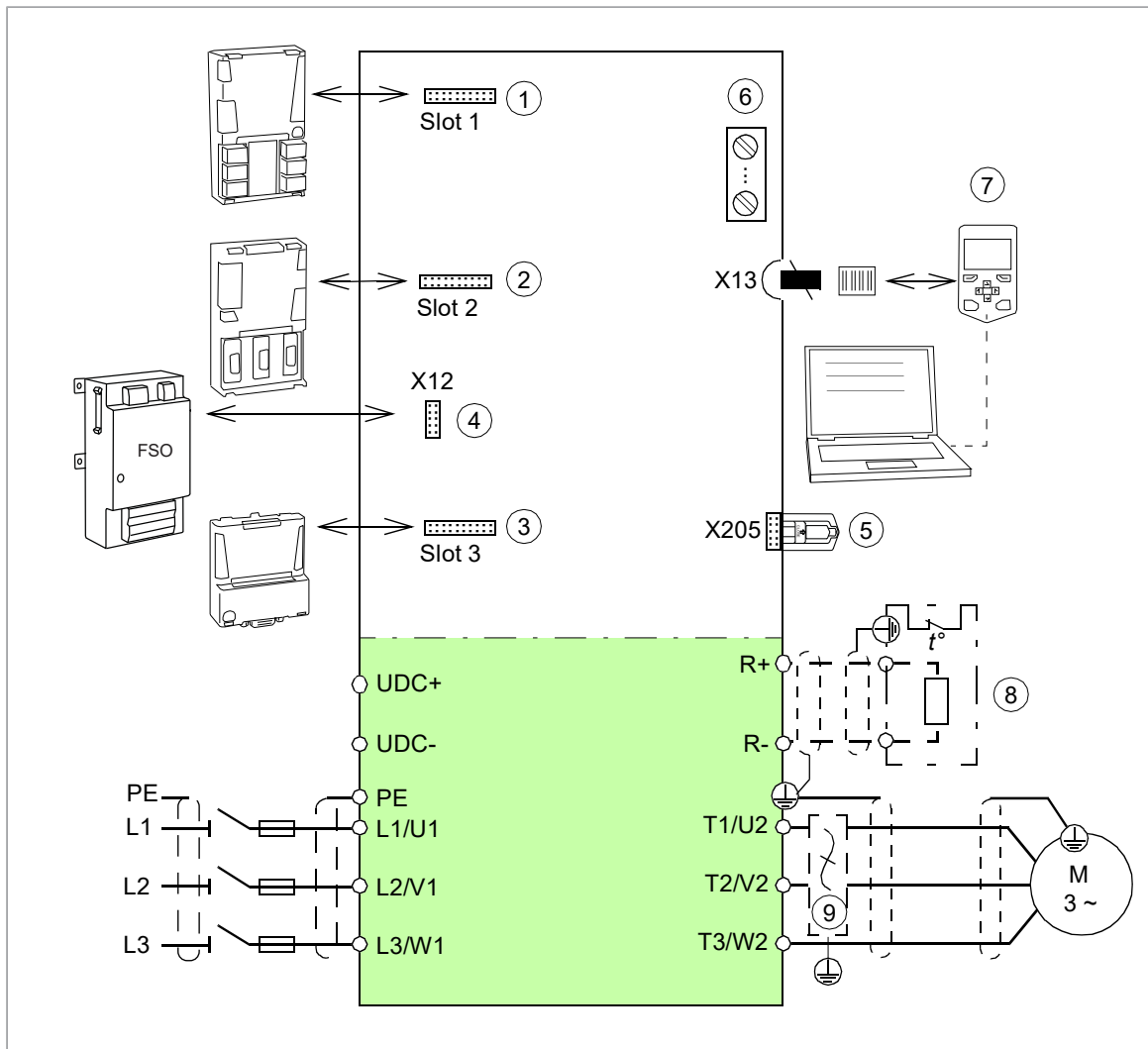

1,2,3	Analog and digital I/O extension modules, feedback interface modules and fieldbus communication modules can be inserted into slots 1, 2 and 3. See section <i>Type designation key</i> .
4	Connector for the FSO-xx safety functions module (X12). The module can be installed on or above the control unit (see <i>Installing the FSO safety functions module (options +Q972 and +Q973)</i>).
5	Memory unit, see <i>Connecting memory unit</i>
6	I/O terminal blocks, see section <i>Default I/O connection diagram</i>
7	Control panel, see section <i>Connecting control panel</i>
8	Brake resistor (optional, see chapter <i>Resistor braking</i>)
9	du/dt or sine filter (optional, see chapter <i>Filters</i>)

Type designation label

The type designation label includes a rating, markings, a type designation and a serial number, which allow individual recognition of each drive module. The type designation label is located on the front cover. An example label is shown below.

ABB ① ACS880-04-330A-7+0B051+D150+0H371

Origin Finland
Made in Finland
ABB Oy
Hiomotie 13
00380 Helsinki
Finland

②

Input U1 3~ 525-600-690 VAC
I1 336-336-330 A
f1 50 / 60 Hz

Output U2 3~ 0-U1
I2 336-336-330 A
f2 0-598 Hz
Sn 394 kVA

③

FRAME
R10

④ Air cooling

⑤ IP00

⑥ Icc 65 kA
SCCR 100 kA

⑦ UL open type
UL, CSA: max. 600 VAC
IE2 (90;100) 1,2 %

⑧

⑨

⑩ CE, EAC, UK CA, TÜV NORD Safety Approved, UL US LISTED IND. CONT. EQ. 1PDB, MSIP-REI-Abb-370A-7, S/N: 1250300741

1	Type designation, see section Type designation key (page 39) .
2	Name and address of the manufacturer
3	Frame size
4	Cooling method
5	Degree of protection
6	Short-circuit withstand strength. See section Electrical power network specification (page 197) .
7	Typical drive losses when it operates at 90% of the motor nominal frequency and 100% of the drive nominal output current (calculated according to IEC61800-9-2).
8	Ratings, see Electrical ratings (page 181)
9	Link to product information
10	Valid markings
11	Serial number. The first digit of the serial number refers to the manufacturing plant. The next four digits refer to the unit's manufacturing year and week, respectively. The remaining digits complete the serial number so that there are no two units with the same number.

Type designation key

The type designation contains information on the specifications and configuration of the drive. The first digits from left express the basic drive type. The optional selections are given next, separated by plus signs. Codes that start with zero (eg. +0A123) indicate the absence of a specified feature. The main selections are described below. The list describes the meaning of the option codes, not availability. Not all selections are available for all types or in all regions. For the availability, refer to the ordering information.

■ Basic code

Code	Description
ACS880	Product series
Type	
-04	The standard delivery includes: drive module to be installed in a cabinet, IP20 (UL Open Type), bookshelf mounting with pedestal, external control unit, ACS-AP-W control panel and panel holder, build-in choke, full-size output cable connection terminals, no EMC filter, no DC connection busbars, clear plastic shrouds for covering the input power and motor cable connections, ACS880 primary control program, Safe torque off function, coated boards, printed multilingual quick installation and start-up guides. Refer to section Option codes (page 40) for options.

40 Operation principle and hardware description

Code	Description
Size	
-xxxxA	See the rating tables
Voltage range	
-3	380...415 V AC. This is indicated in the type designation label as typical input voltage level (3~ 400 V AC)
-5	380...500 V AC. This is indicated in the type designation label as typical input voltage levels (3~ 400/480/500 V AC)
-7	525...690 V AC. This is indicated in the type designation label as typical input voltage levels (3~ 525/600/690 V AC)

■ Option codes

Code	Description
0B051	No IP20 shrouds for cabling area
C132	Marine type approval
C173	Flat mounting
C205	Marine product certification issued by DNV GL
C206	Marine product certification issued by the American Bureau of Shipping (ABS)
C207	Marine product certification issued by Lloyd's Register (LR)
C208	Marine product certification issued by Registro Italiano Navale (RINA)
C209	Marine product certification issued by Bureau Veritas
C210	Marine product certification issued by Nippon Kaiji Kyokai (NK)
C227	Marine product certification issued by Korean Register of Shipping (KR)
C228	Marine product certification issued by China Classification Society (CCS)
C229	Marine product certification issued by Russian Maritime Register of Shipping (RS)
C255	Nickel plated busbars
D150	Brake choppers
E200	EMC filter for 2nd environment TN (grounded) system, category C3
E201	EMC filter for 2nd environment IT (ungrounded) system, category C3
E202	EMC filter for 1st environment TN (grounded) system, category C2
E208	Common mode filter
0H354	No standard wheeled pedestal. The drive module is equipped with a low pedestal to which the bottom grille can be attached if IP20 degree of protection is needed from bottom. Requires option +0P919.
0H371	No full size cable connection terminals for output power cables
H356	DC connection busbars
H370	Full-size input terminals
H381	Full power cabling panels to be attached to a cabinet. The drive module can be pulled out from the cabinet without disconnecting the power cables. IP20 degree of protection.
H391	Power cable terminals on the right-hand side. Includes accessories for mounting the drive module in the back to front position. Not to be used with options +P905, +H381 and +C173.
0J400	No control panel
J410	DPMP-01 door mounting kit
J413	DPMP-02 door mounting kit (surface mounting) for the panel
J414	Control panel holder integrated in the unit (requires option P905, integrated control unit)

Code	Description
J425	ACS-AP-I control panel
J461	ACS-DCP-11 drive connectivity panel (EU variant)
K451	FDNA-01 DeviceNet™ adapter module
K454	FPBA-01 PROFIBUS DP adapter module
K457	FCAN-01 CANopen adapter module
K458	FSCA-01 RS-485 (Modbus/RTU) adapter module
K462	FCNA-01 ControlNet™ adapter module
K469	FECA-01 EtherCat adapter module
K470	FEPL-02 EtherPOWERLINK adapter module
K490	FEIP-21 EtherNet/IP adapter module
K491	FMBT-21 Modbus/TCP adapter module
K492	FPNO-21 PROFINET IO adapter module
L500	FIO-11 analog I/O extension module (1, 2 or 3 pcs)
L501	FIO-01 digital I/O extension module
L502	FEN-31 HTL incremental encoder interface module
L503	FDCO-01 optical DDCS communication adapter module
L508	FDCO-02 optical DDCS communication adapter module
L515	FEA-03 I/O extension adapter
L516	FEN-21 resolver interface module
L517	FEN-01 TTL incremental encoder interface module
L518	FEN-11 TTL absolute encoder interface module
L521	FSE-31 pulse encoder interface module
L525	FAIO-01 analog I/O extension module
L526	FDIO-01 digital I/O extension module
L536	FPTC-01 thermistor protection module
L537	FPTC-02 ATEX-certified thermistor protection module
N5000	Winder control program
N5050	Crane control program
N5100	Winch control program
N5150	Centrifuge control program
N5200	PCP (Progressive Cavity Pump) control program
N5250	Rod pump control program
N5350	Cooling tower control program
N5450	Override control program
N5500	Spinning and traverse control program
N5600	ESP (Electrical Submersible Pump) control program
N5650	Tower crane control program
N7500	High-speed control firmware. High-speed operation above 598 Hz output frequency.
N7502	Control program for synchronous reluctance motors (SynRM)
N8010	Drive application programming
N8200	Dual-use license for an operating range of 600 Hz and more
OP919	No extraction/installation ramp

42 Operation principle and hardware description

Code	Description
P904	Extended warranty (24 months from commissioning or 30 months from delivery)
P905	Integrated control unit (inside drive module)
P909	Extended warranty (36 months from commissioning or 42 months from delivery)
P911	Extended warranty (60 months from commissioning or 66 months from delivery)
P912	Seaworthy packaging
P952	European Union Country of Origin
Q971	ATEX-certified safe disconnection function
Q972	FSO-21 safety functions module
Q973	FSO-12 safety functions module
Q982	PROFIsafe with FSO-xx safety function module and FPNO-21 PROFINet adapter or FENA-21 Ethernet adapter module
Q986	PROFIsafe safety functions module, FSPS-21
Q989	CIP Safety™ functions module, FSCS-21
R700	Printed manuals in English
R701	Printed manuals in German ¹⁾
R702	Printed manuals in Italian ¹⁾
R703	Printed manuals in Dutch ¹⁾
R704	Printed manuals in Danish ¹⁾
R705	Printed manuals in Swedish ¹⁾
R706	Printed manuals in Finnish ¹⁾
R707	Printed manuals in French ¹⁾
R708	Printed manuals in Spanish ¹⁾
R709	Printed manuals in Portuguese ¹⁾
R711	Printed manuals in Russian ¹⁾
R712	Printed manuals in Chinese ¹⁾
R713	Printed manuals in Polish ¹⁾
R714	Printed manuals in Turkish ¹⁾
V998	UCU-20 control unit

¹⁾ Manuals in English may be included if a translation in the specified language is not available.



4

Guidelines for planning the mechanical installation

Contents of this chapter

This chapter guides in planning drive cabinets and installing the drive module into a user-defined cabinet. The chapter gives cabinet layout examples and free space requirements around the module for cooling. These drive-specific guidelines are essential for the safe and trouble-free use of the drive system.

Installation positions of the drive module

You can install the drive module in a bookshelf or flat position or on its back in a cabinet.

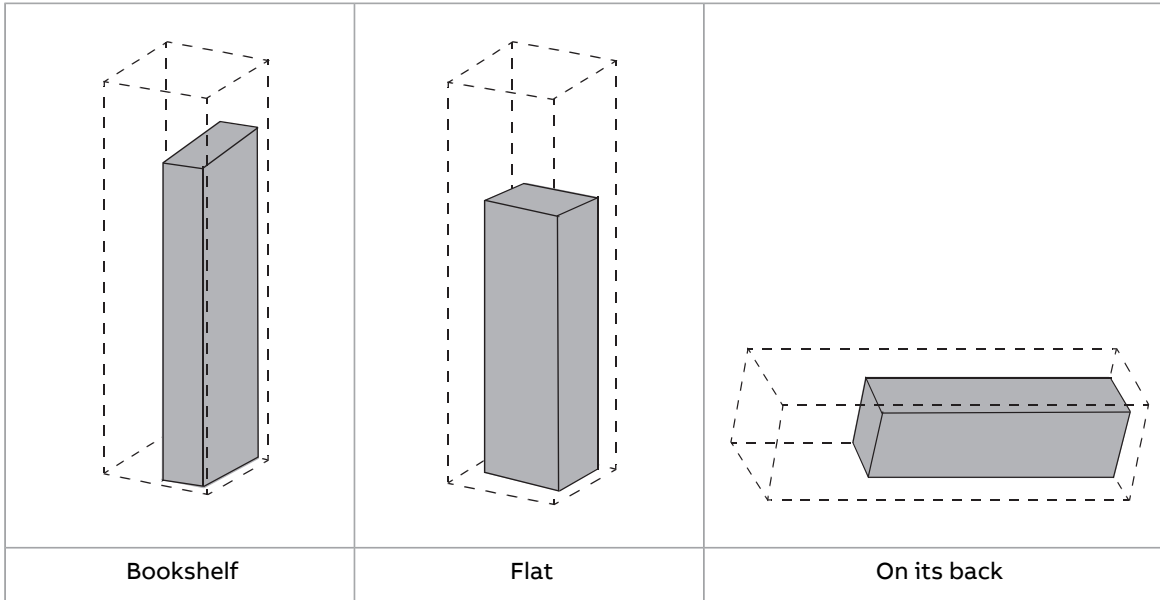

Planning the layout

■ Layout example, door closed

This diagram shows a cabinet layout example with the input power cable entry from top and the motor cable entry from bottom.

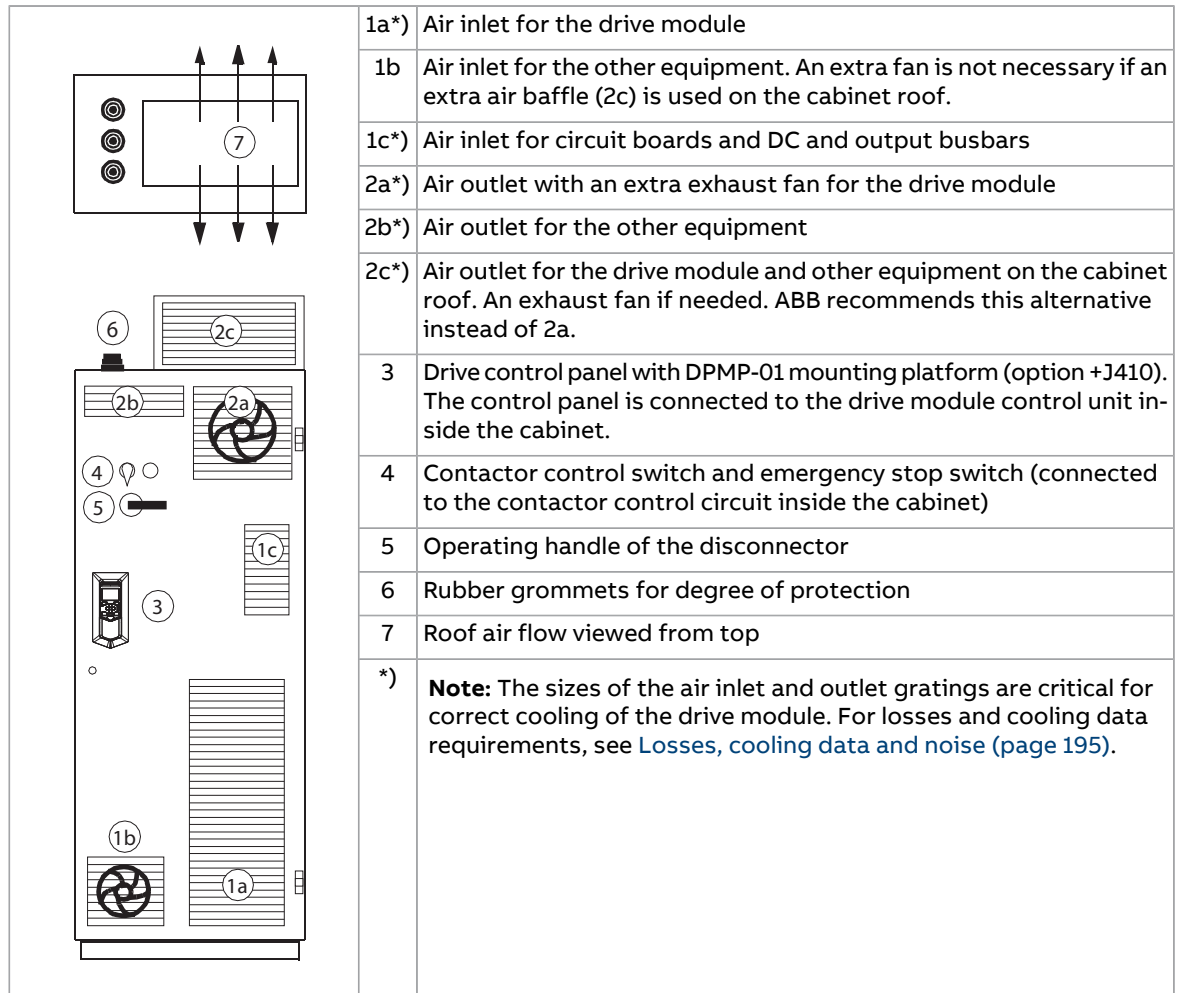

■ **Layout example, door open (standard drive module configuration)**

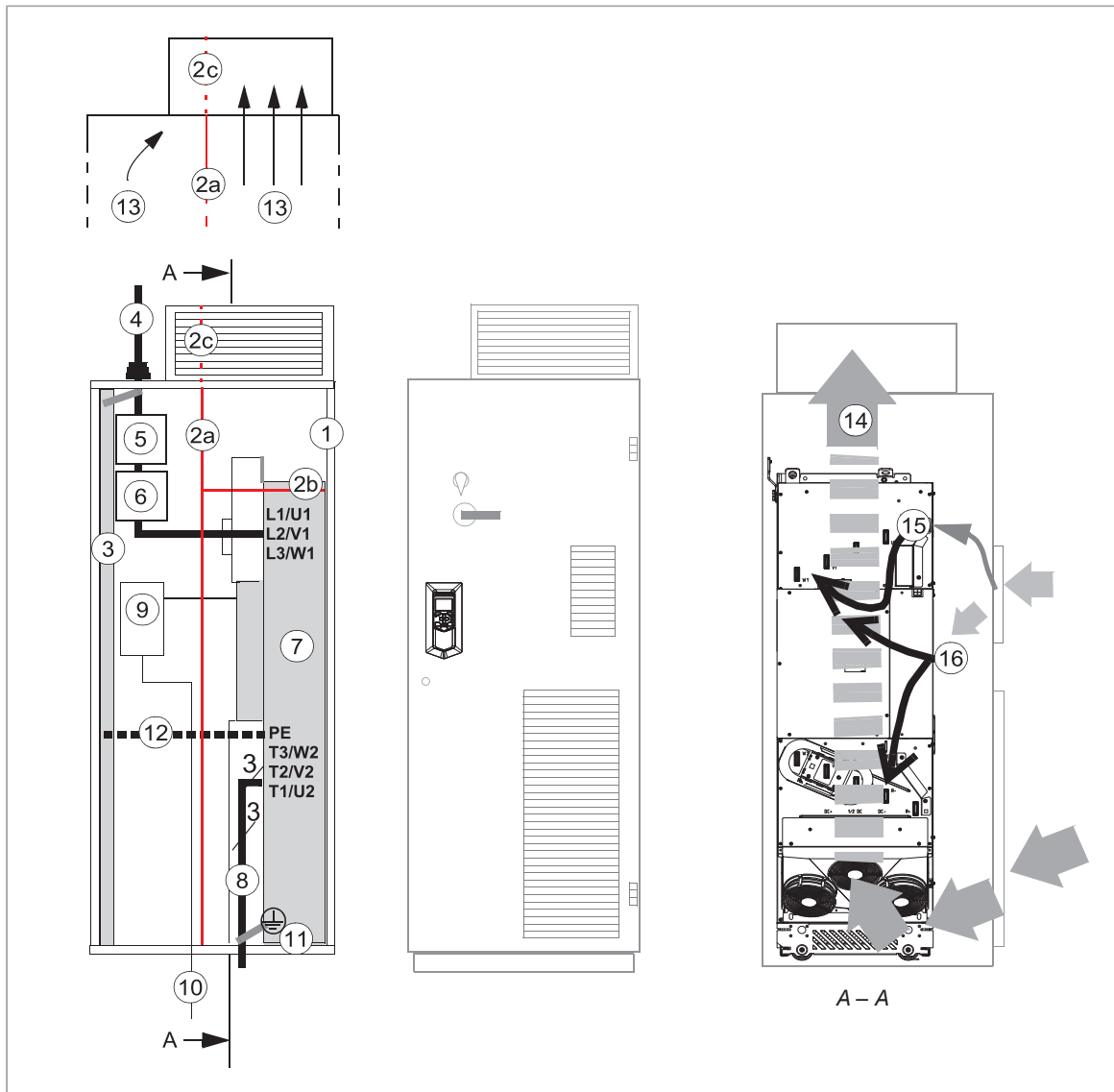

1	Supporting frame of the cabinet	8	Motor cable including the protective ground conductor of the drive module
2a	Vertical (2a) and horizontal (2b) air baffles that separate the cool and hot areas (leakproof lead-throughs).	9	Drive module control unit. Note: With an integrated control unit (option +P905), the upper door air inlet is critical for proper cooling of the control board.
2b		10	External control cables
2c	Optional air baffle that is needed when there is no fan on the lower part of the cabinet door (see 1b (page 45))	11	Grounding screws
3	Cabinet grounding busbar (PE)	12	Alternative to grounding screws (11)
4	Input power cable including the protective ground conductor (PE) of the drive	13	Air flow to the roof
5	Disconnecter and fuses	14	Air flow through the drive module
6	Contacteur	15	Air flow to circuit boards and DC and output busbars
7	Drive module	16	Air flow to the brake option

■ Layout example, door open (option +H391)

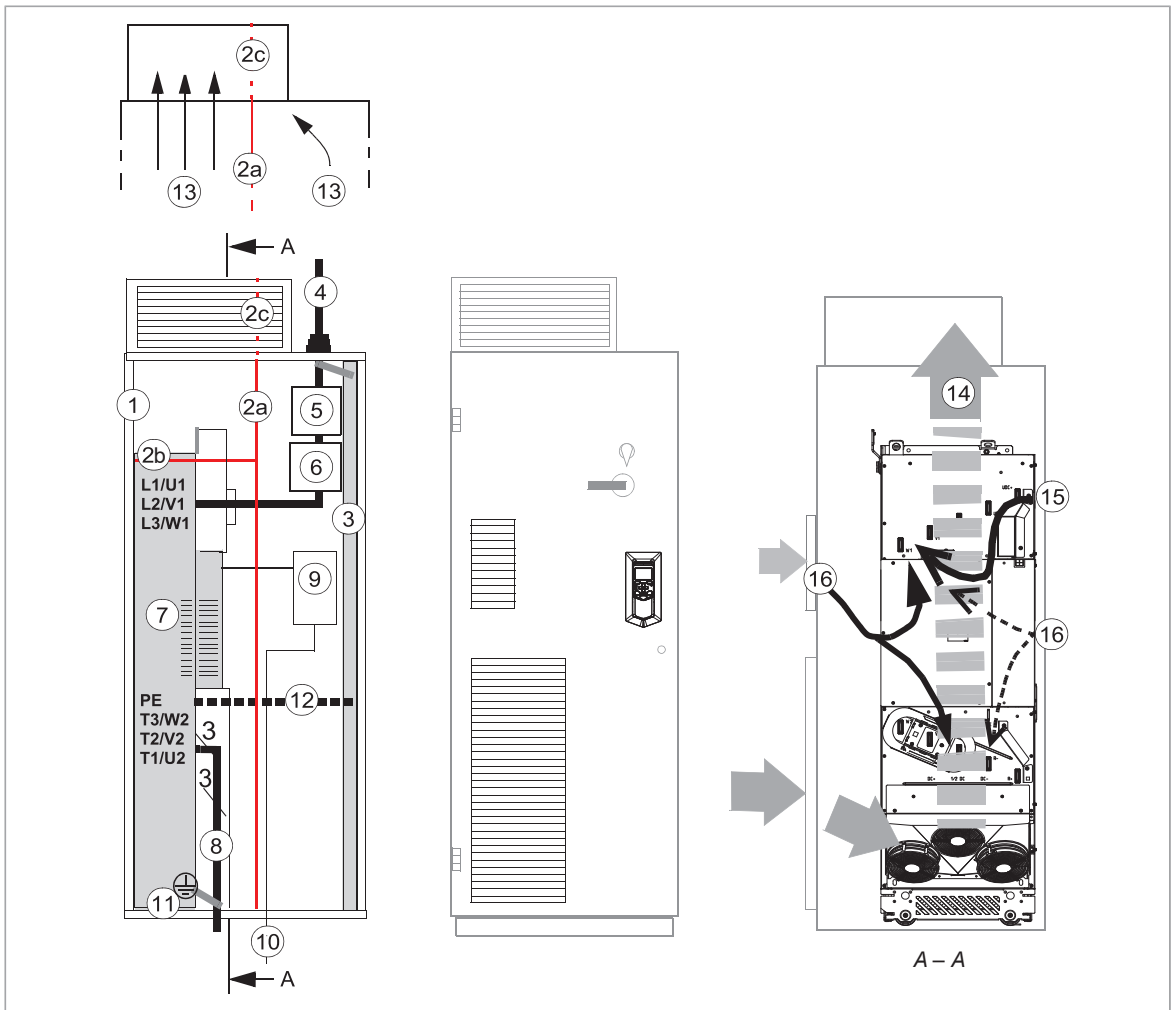

1	Supporting frame of the cabinet	8	Motor cable including the protective ground conductor of the drive module
2a 2b	Vertical (2a) and horizontal (2b) air baffles that separate the cool and hot areas (leakproof lead-throughs).	9	Drive module control unit. Note: With an integrated control unit (option +P905), the upper door air inlet is critical for proper cooling of the control board.
		10	External control cables
2c	Optional air baffle that is needed when there is no fan on the lower part of the cabinet door (see 1b (page 45))	11	Grounding screws
3	Cabinet grounding busbar (PE)	12	Alternative to grounding screws (11)
4	Input power cable including the protective ground conductor (PE) of the drive	13	Air flow to the roof
5	Disconnecter and fuses	14	Air flow through the drive module
6	Contactors	15	Air flow to circuit boards and DC and output busbars
7	Drive module	16	Air flow to the brake option

■ **Layout example, door open (option +OB051)**

This diagram shows a layout example for drive modules with no IP20 shrouds (option +OB051) or no cabling panels (option +H381 not included).

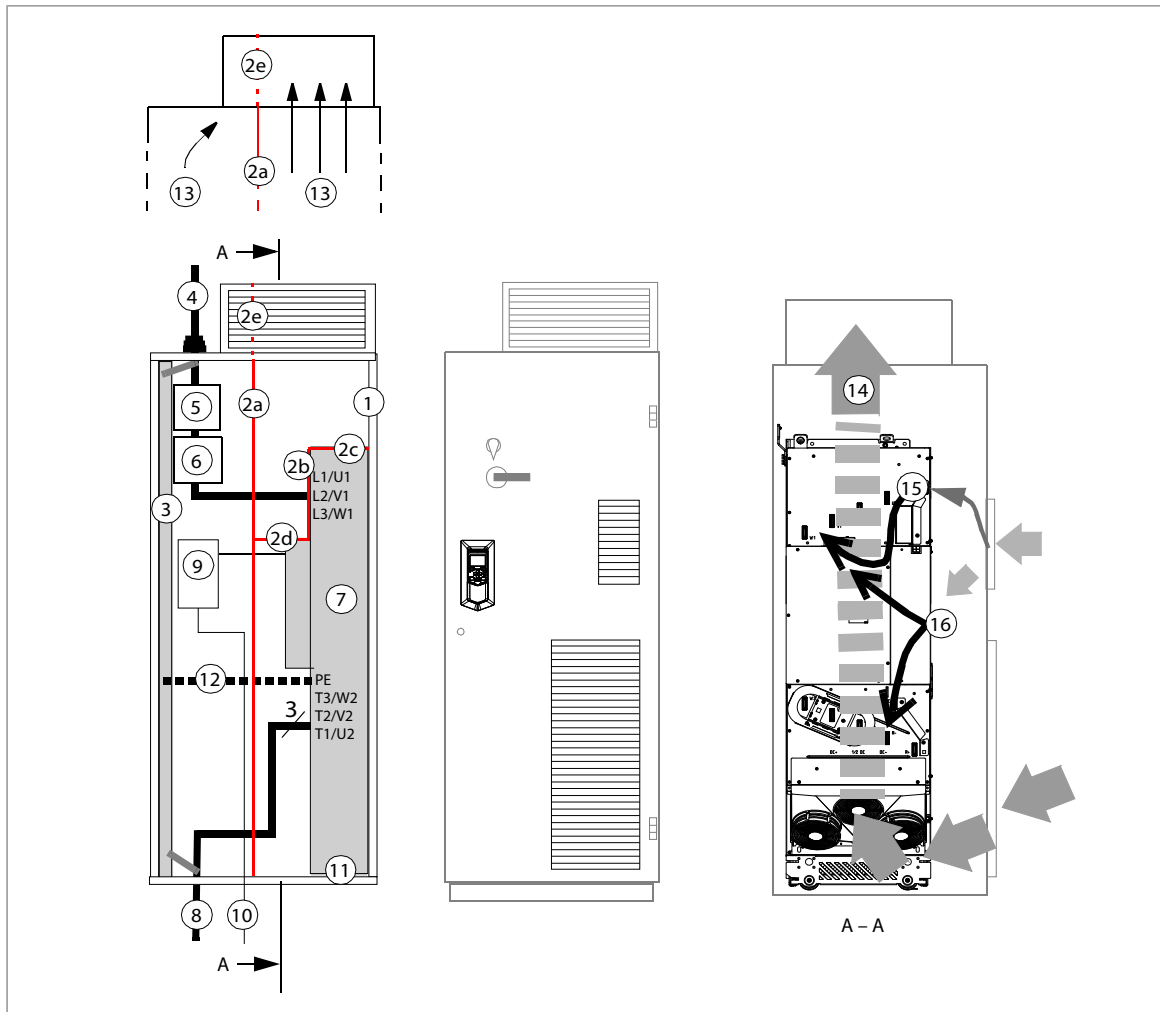

1	Supporting frame of the cabinet	8	Motor cable including the protective ground conductor of the drive module
2	Vertical (2a, 2b) and horizontal (2c, 2d) air baffles that separate the cool and hot areas (leakproof lead-throughs).	9	Drive module control unit. Note: With an integrated control unit (option +P905), the upper door air inlet is critical for proper cooling of the control board.
2e	Optional air baffle that is needed when there is no fan on the lower part of the cabinet door (see 1b (page 45))	10	External control cables
3	Cabinet grounding busbar (PE)	11	Grounding screws
4	Input power cable including the protective ground conductor (PE) of the drive	12	Alternative to grounding screws (11)
5	Disconnecter and fuses	13	Air flow to the roof
6	Contactor	14	Air flow through the drive module
7	Drive module	15	Air flow to circuit boards and DC and output busbars
		16	Air flow to the brake option

Note: The power cable shields can also be grounded to the drive module grounding terminals.

■ **Bookshelf mounting (standard drive module configuration)**

This diagram shows the air baffle position inside an example cabinet. For dimensions of the baffle, see [Air baffles for the standard drive module and option +C173](#) (page 227).

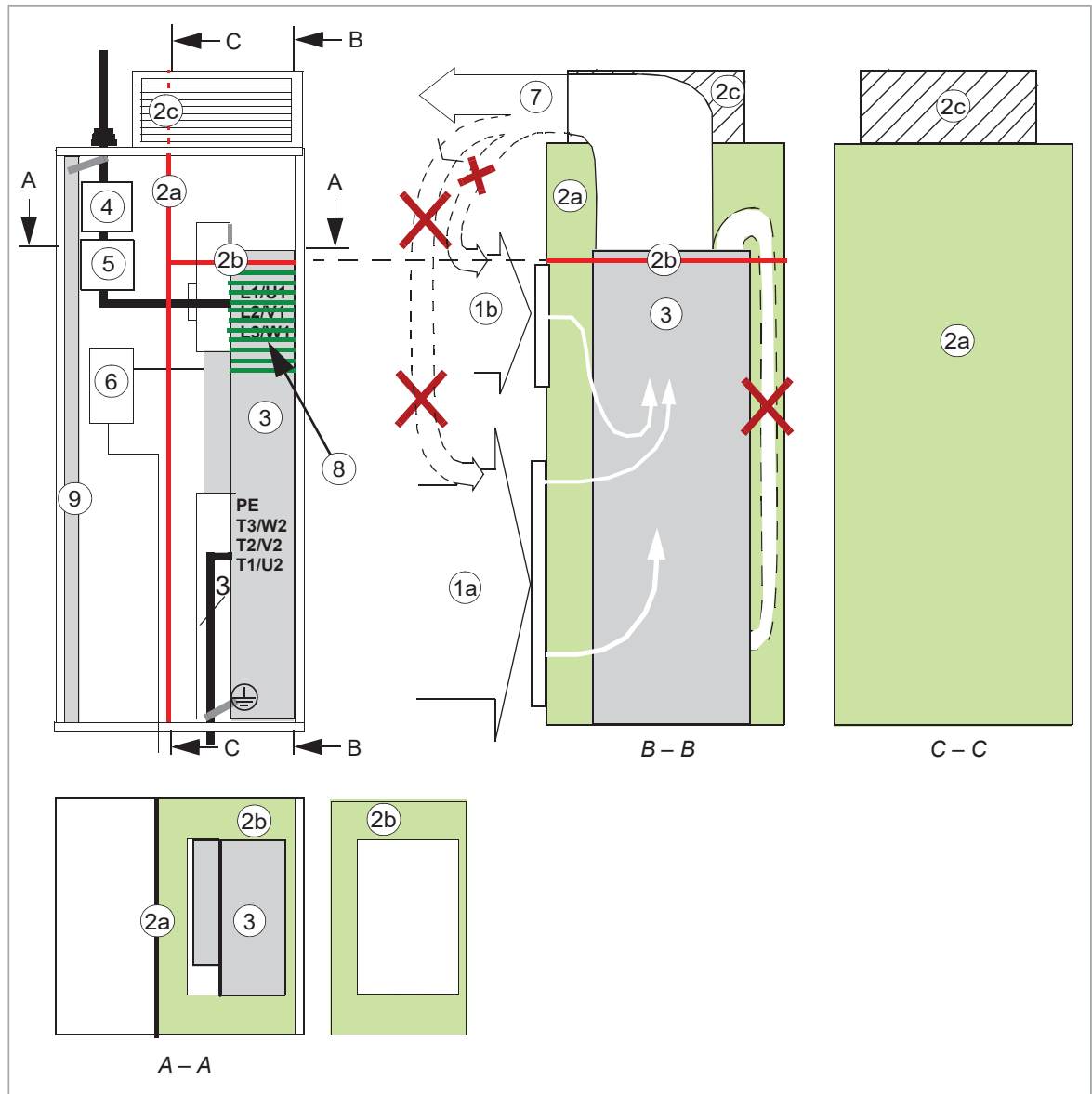

1a	Air flow to the drive module, max. 40 °C (104 °F)	4	Disconnectors and fuses
1b	Air flow to the drive circuit boards and DC and output busbars	5	Contactors
2a	Vertical air baffle that separates the cool and hot areas in the cabinet	6	Drive module control unit
2b	Horizontal air baffle	7	Air flow out
2c	Optional air baffle that is needed when there is no fan on the lower part of the cabinet door (see 1b (page 45))	8	Note: The upper grating in the cabinet door must be located in the area marked with the horizontal shading lines for correctly directed cooling air flow to the circuit board compartment of the drive module.
3	Drive module	9	Cabinet grounding busbar (PE)

■ **Bookshelf mounting (option +OB051)**

This diagram shows the air baffle position inside an example cabinet. For the descriptions, see the next page.

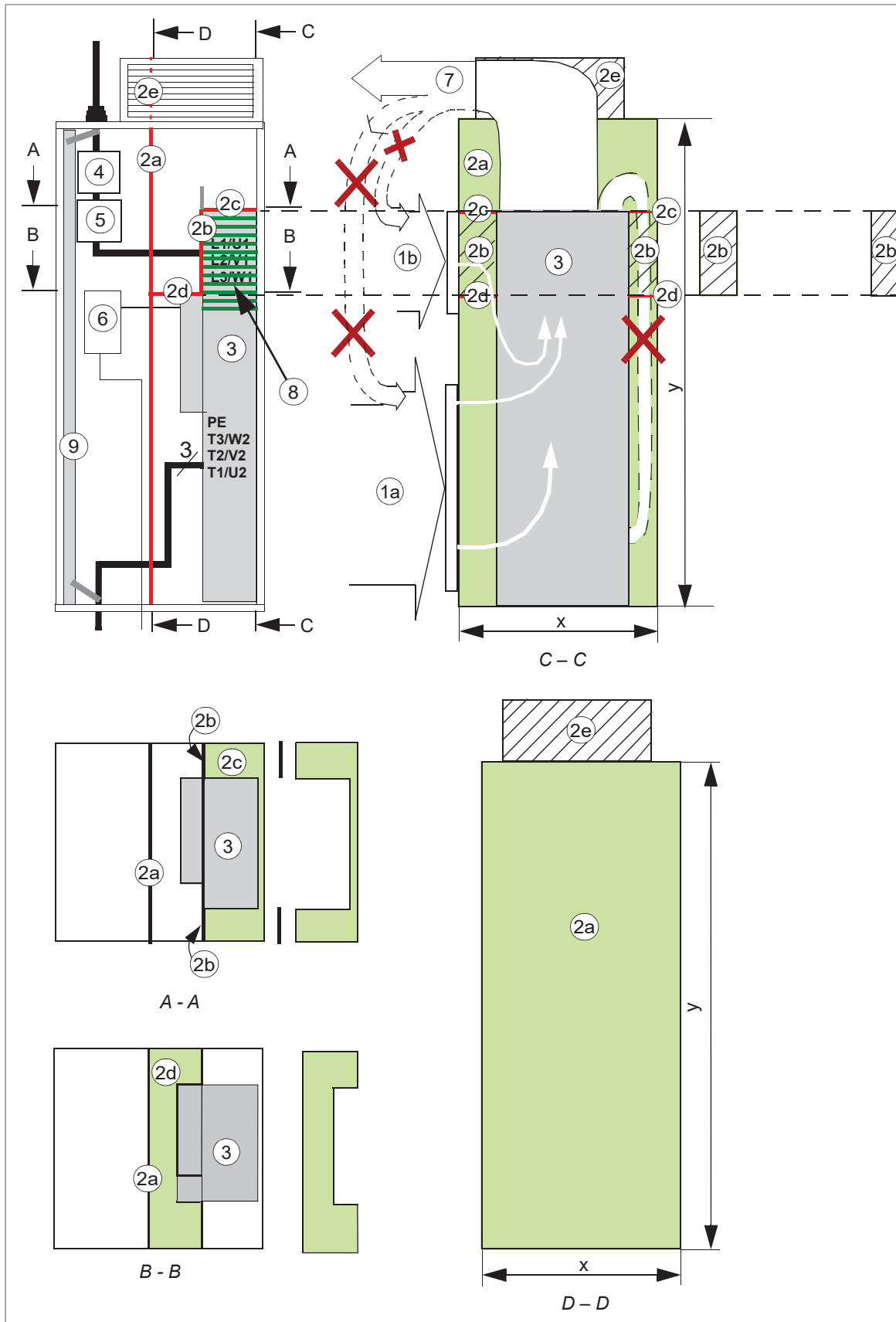

1a	Air flow to the drive module, max. 40 °C (104 °F)	3	Drive module
1b	Air flow to the drive circuit boards and DC and output busbars	4	Disconnecter and fuses
2a	Vertical air baffle that separates the cool and hot areas in the cabinet	5	Contactator
2b	Vertical air baffle	6	Drive module control unit
2c	Upper horizontal air baffle	7	Air flow out
2d	Lower horizontal air baffle	8	Upper grating in the cabinet door Note: The grating must be located in the area marked with the horizontal shading lines for correctly directed cooling air flow to the circuit board compartment of the drive module.
2e	Optional air baffle that is needed when there is no fan on the lower part of the cabinet door (see 1b (page 45))	9	Cabinet grounding busbar (PE)

■ **Bookshelf mounting (option +H381)**

See [Step-by-step drawings for installation example 2 - Bookshelf installation \(option +H381\) in a Rittal VX25 400 mm enclosure \(page 265\)](#) and [Air baffles for option +H381 in Rittal VX25 400 mm wide enclosure installation \(page 228\)](#).

■ Flat mounting (option +C173)

This diagram shows the air baffle position inside an example cabinet. For dimensions of the baffle, see [Air baffles for the standard drive module and option +C173 \(page 227\)](#).



1a	Air flow to the drive module, max. 40 °C (104 °F)	5	Contactors
1b	Air flow to the drive circuit boards and DC and output busbars	6	Drive module control unit
2	Horizontal air baffle	7	Air flow out
3	Drive module	8	Air gap between the drive module front and cabinet wall for cooling air flow
4	Disconnectors and fuses	9	Cabinet grounding busbar (PE)

■ Flat mounting (option +C173 + 0B051)

This diagram shows the air baffle position inside an example cabinet.

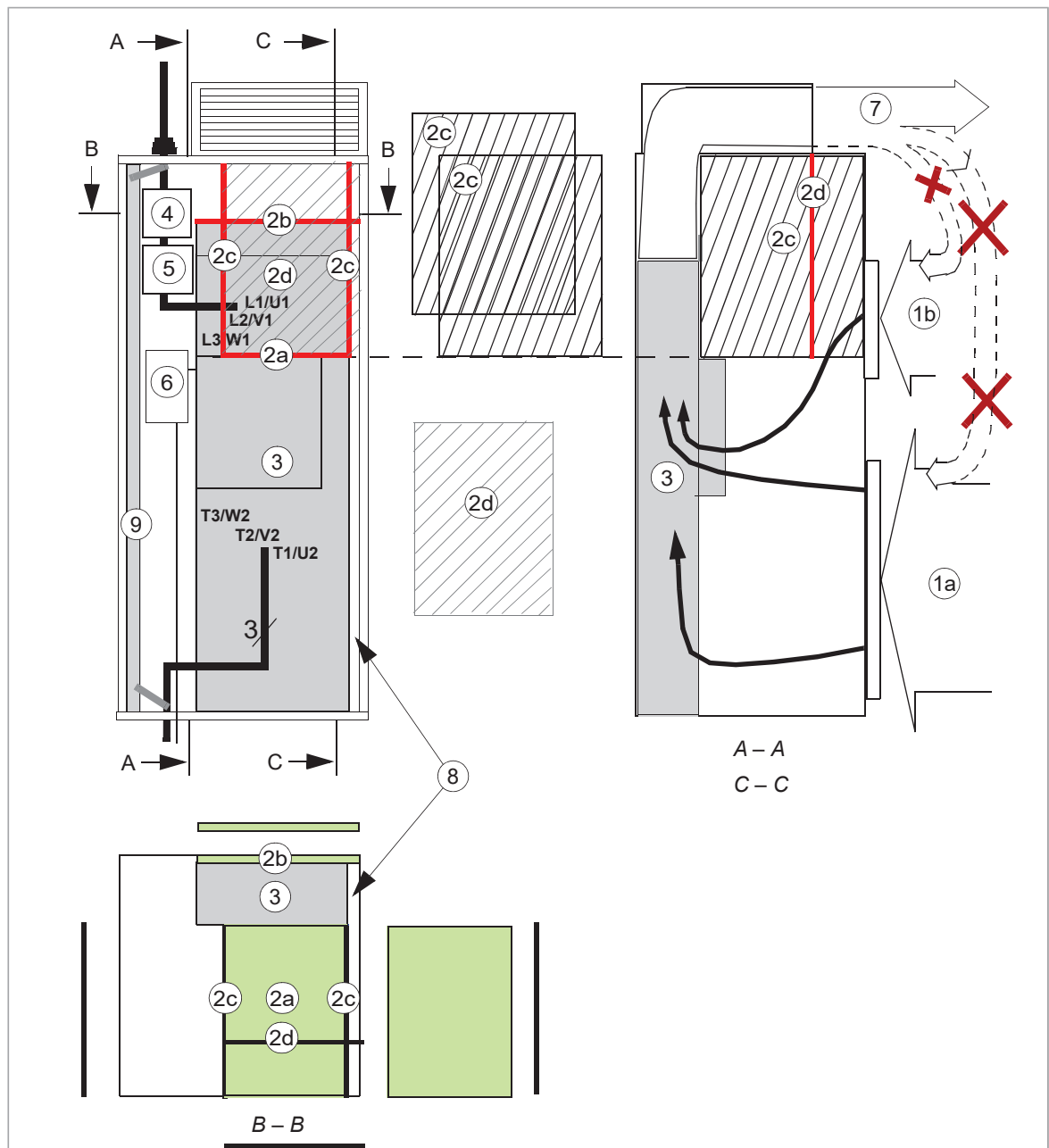

1a	Air flow to the drive module, max. 40 °C (104 °F)	4	Disconnecter and fuses
1b	Air flow to the drive circuit boards and DC and output busbars	5	Contactor
2a	Horizontal air baffles that guide cooling air flow	6	Drive module control unit
2b	Horizontal air baffle	7	Air flow out
2c	Vertical air baffle	8	Air gap between the drive module front and cabinet wall for cooling air flow
2d	Vertical air baffle that guides air flow to the inside the drive module	9	Cabinet grounding busbar (PE)
3	Drive module	-	-

Free space requirements

Free space around the drive module is needed to make sure that sufficient cooling air flows through the module and the module cools correctly.

■ Free space at the top of the drive module

The free space requirement at the top of the module is shown below.

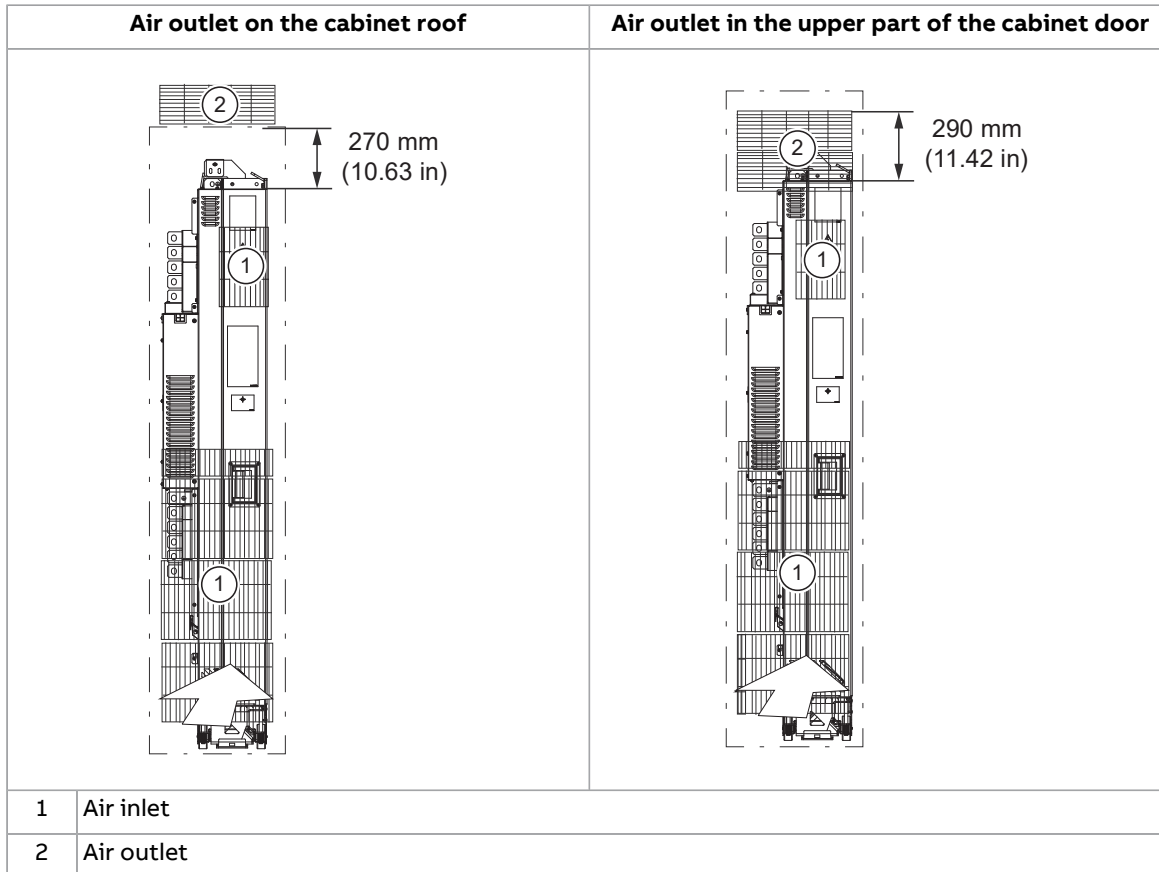

■ Free space around the drive module

Bookshelf installation: 10 mm (0.39 in) free space around the drive module is required from the cabinet back panel and front door. No free space for cooling is required on the left- and right-hand sides of the module.

The module can be installed in a cabinet with the following dimensions:

- width 400 mm (15.75 in)
- depth 600 mm (23.62 in)
- height 2000 mm (78.74 in).

■ Free space below the drive module

Standard drive module: No free space for cooling is required at the bottom of the drive module.

Low pedestal (options +C173 and +0H354):

- No free space for cooling is required below the drive module when the module is installed in a cabinet.
- 200 mm (7.87 in) free space is required below the drive module when the module is installed on a wall.

Installation positions other than vertical

You can install the drive module on its back. Make sure that the hot cooling air which flows upwards from the module does not cause danger.

For other installation positions, contact ABB.

ABB air inlet and outlet kits

See [Cabinet ventilation \(page 176\)](#).

5

Mechanical installation

Contents of this chapter

This chapter describes how to install the drive module mechanically without the clear plastic shrouds. The shrouds are attached after the power cabling.



Safety



⚠ WARNING

Lift the drive module only by the lifting lugs:

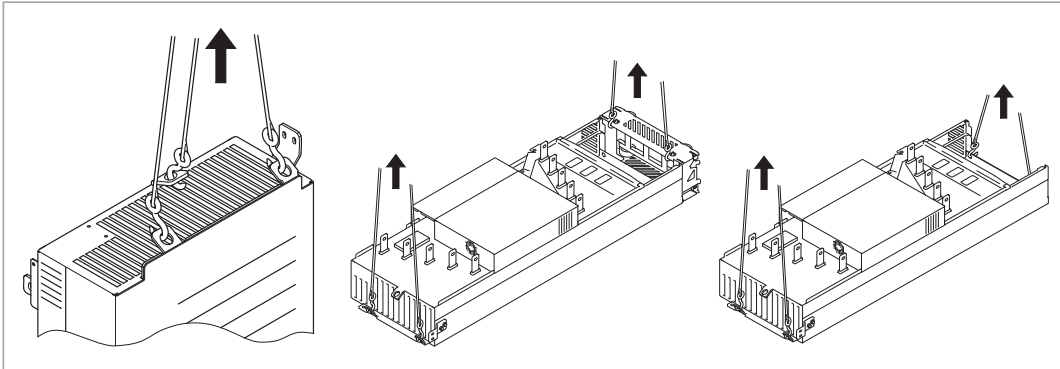

Make sure that the module does not topple over when you move it on the floor: To open the support legs, press each leg a little down (1, 2) and turn it aside. Whenever possible attach the module also with chains. Do not tilt the module. It is heavy and its center of gravity is high. The module overturns from a sideways tilt of 5 degrees. Do not leave the module unattended on a sloping floor.

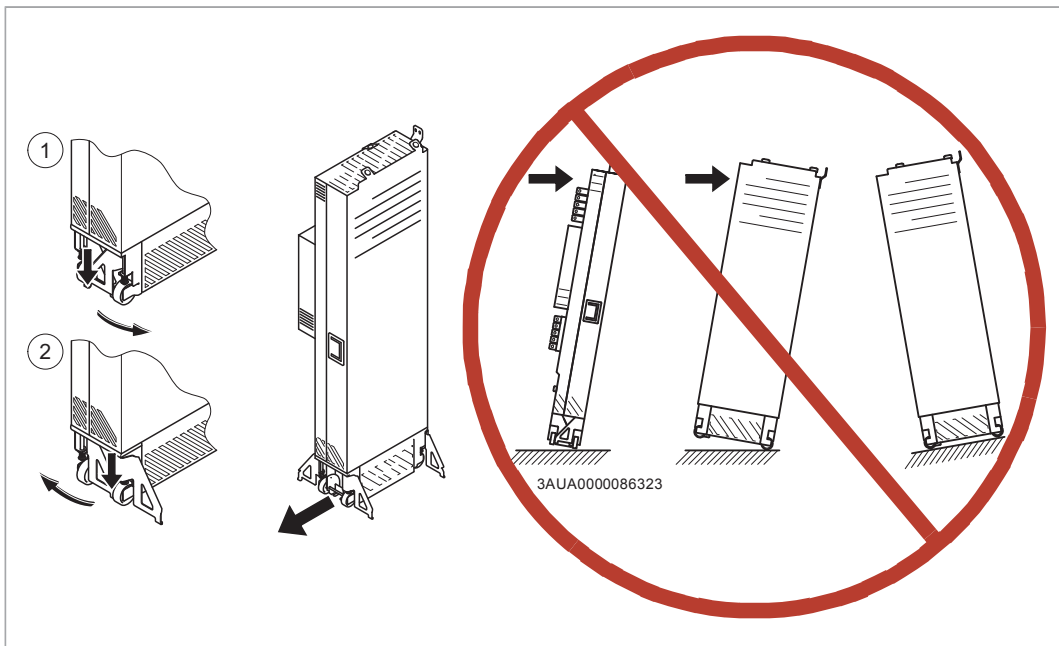

Examining the installation site

Examine the installation site. Make sure that:

- The installation site is sufficiently ventilated or cooled to remove heat from the drive. Refer to the technical data.
- The ambient conditions of the drive meet the specifications. Refer to the technical data.

- The material behind, above, and below the drive is non-flammable.
- There is sufficient free space around the drive for cooling, maintenance work, and operation. Refer to the free space specifications for the drive.
- There are no sources of strong magnetic fields such as high-current single-core conductors or contactor coils near the drive. A strong magnetic field can cause interference or inaccuracy in the operation of the drive.

Moving and unpacking the unit



▲WARNING Obey the safety instructions of the drive. If you ignore them, injury or death, or damage to the equipment can occur. If you are not a qualified electrical professional, do not do electrical installation, commissioning or maintenance work.

■ Moving the drive module

Move the drive module in its transport package to the installation site.

■ Unpacking

Unpack the package as follows, see section [Package drawings \(page 60\)](#):

- Cut the bands (A).
- Unpack the additional boxes (B).
- Remove the outer sheathing by lifting it (C).
- Remove the sheathing by lifting it (D).
- Remove the pedestal guide plate as shown below (not included with options +OH354 and +OP919).

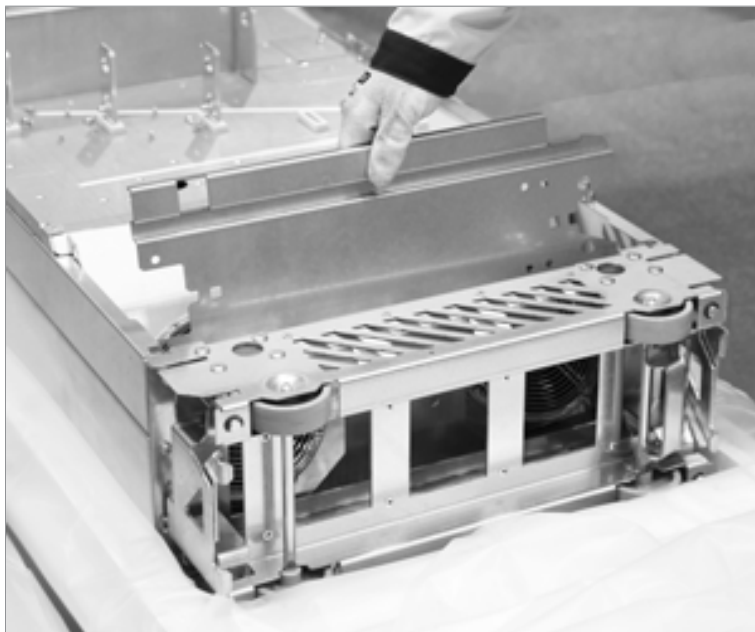

Package drawings

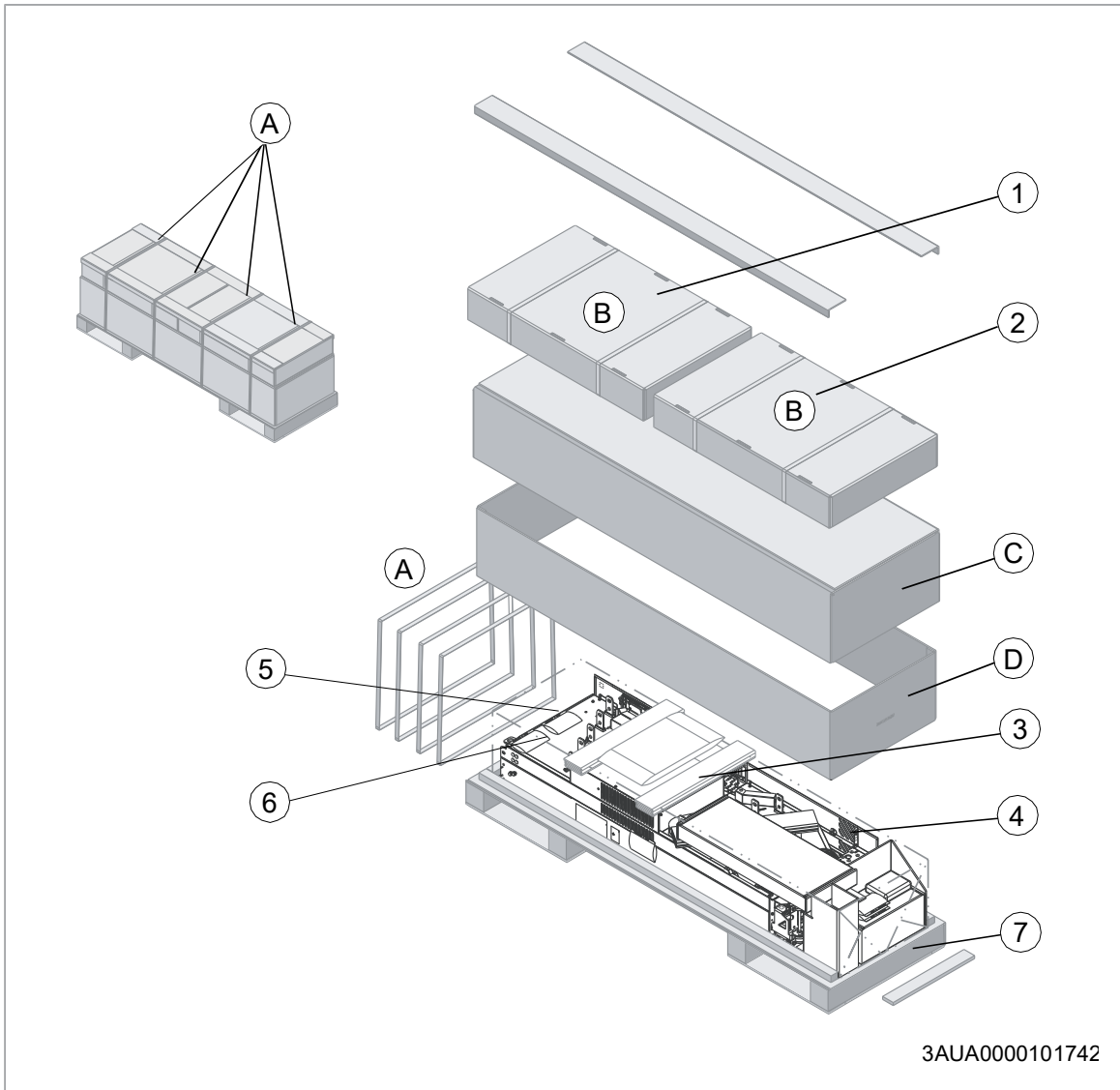

Transport package contents	
1	<p><u>With standard drive module configuration:</u> Clear plastic shrouds. <u>With option +H381:</u> Input cabling panel parts. See below for the box contents.</p>
2	<p><u>With standard drive module configuration:</u> Output cable connection terminals. With option +H370 also input cable connection terminals. <u>With option +H381:</u> Output cabling panel parts. See below for the box contents.</p>
3	Plywood support
4	<p>Drive module with factory installed options and multilingual residual voltage warning sticker, top guide plate, pedestal guide plate, telescopic ramp package, fastening screws in a plastic bag, external control unit with control cable clamp plate and factory installed option modules, control panel and cable or control panel with door mounting kit (option +J410), delivery documents and a printed multilingual quick installation and start-up guide. Other printed manuals with option +R7xx.</p>
5	<u>With option +C173:</u> Back fastening bars
6	<u>With option +H391:</u> Accessories for mounting
7	Pallet

3AXD10000407466

Option +H391: Top and bottom brackets and handle	
1	Top bracket
2	Bottom bracket
3	Handle
4	Screw package
5	Cardboard package

3AXD50000013807

Box B1 contents (standard drive module configuration)	
1	Paper fill
2	Clear plastic shroud for output power cabling
3	Mounting bracket for bottom grille
4	Cardboard box bottom
5	Cardboard box cover
6	Bottom grille
7	Support
8	Straps
9	Screws in a plastic bag
10	Back clear plastic shroud (upper)
11	Back clear plastic shroud (lower)
12	Front clear plastic shroud
13	Clear plastic shroud for input power cabling
14	Top clear plastic shroud
15	Entry clear plastic shroud for side input cabling
16	Clear plastic bottom shroud 1
17	Clear plastic bottom shroud 2
18	Metallic shroud



62 Mechanical installation

3AXD50000478613

Box B1 contents with option +H381: Input power cabling panel parts	
1	Screw package
2	Paper fill
3	Grounding busbar to be connected to the input power cabling panel and the drive module
4	Bracket
5	Cardboard tray
6	Top cardboard cover
7	Rubber grommet
8	Support
9	Bands
10	Plastic bag
11	Input power cabling panel
12	Top guide

3AXD5000009515

Box B2 contains this box with standard drive module configuration	
1	Paper fill
2	Output cable connection terminal T3/W2
3	Output cable connection terminal T2/V2
4	Output cable connection terminal T1/U2
5	Grounding terminal
6	Cardboard box
7	Screws and insulators in a plastic bag



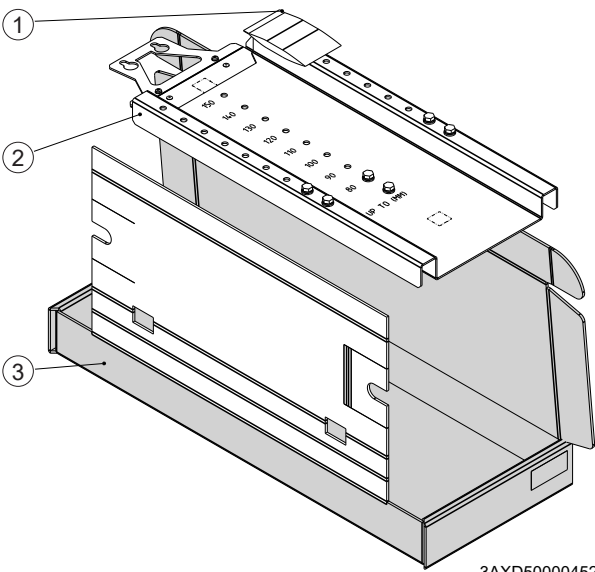

3AXD50000452965

Ramp box contents	
1	Screw package
2	Telescopic extraction and insertion ramp
3	Cardboard box

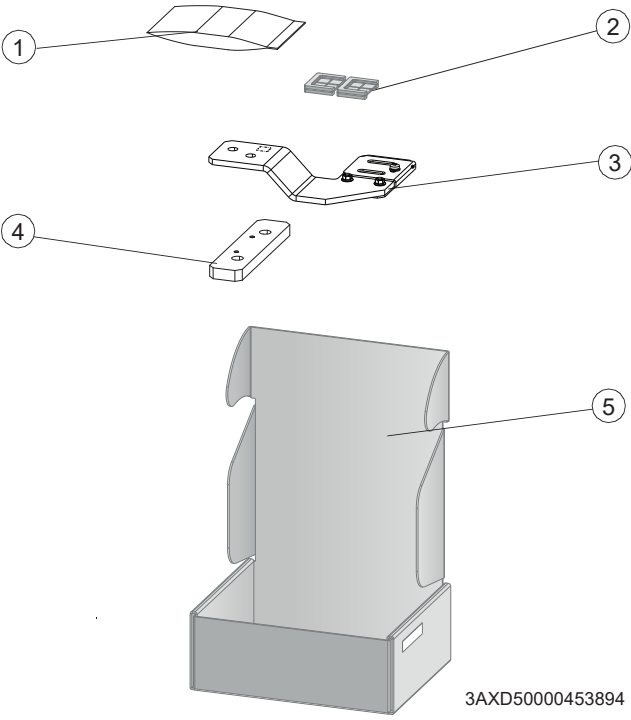

3AXD50000453894

Accessory box contents: Assembly kit 3AXD50000453900	
1	Screw package, includes also spacers for FSO module installation
2	Rubber grommets for control unit cable entry holes in the middle front cover of the drive module
3	Fastener for Rittal VX25 enclosure
4	Bracket for attaching the drive module from top (3AUA0000096082). The bracket brings a gap for cooling air flow and prevents the drive module screws from chafing the plate.
5	Cardboard box



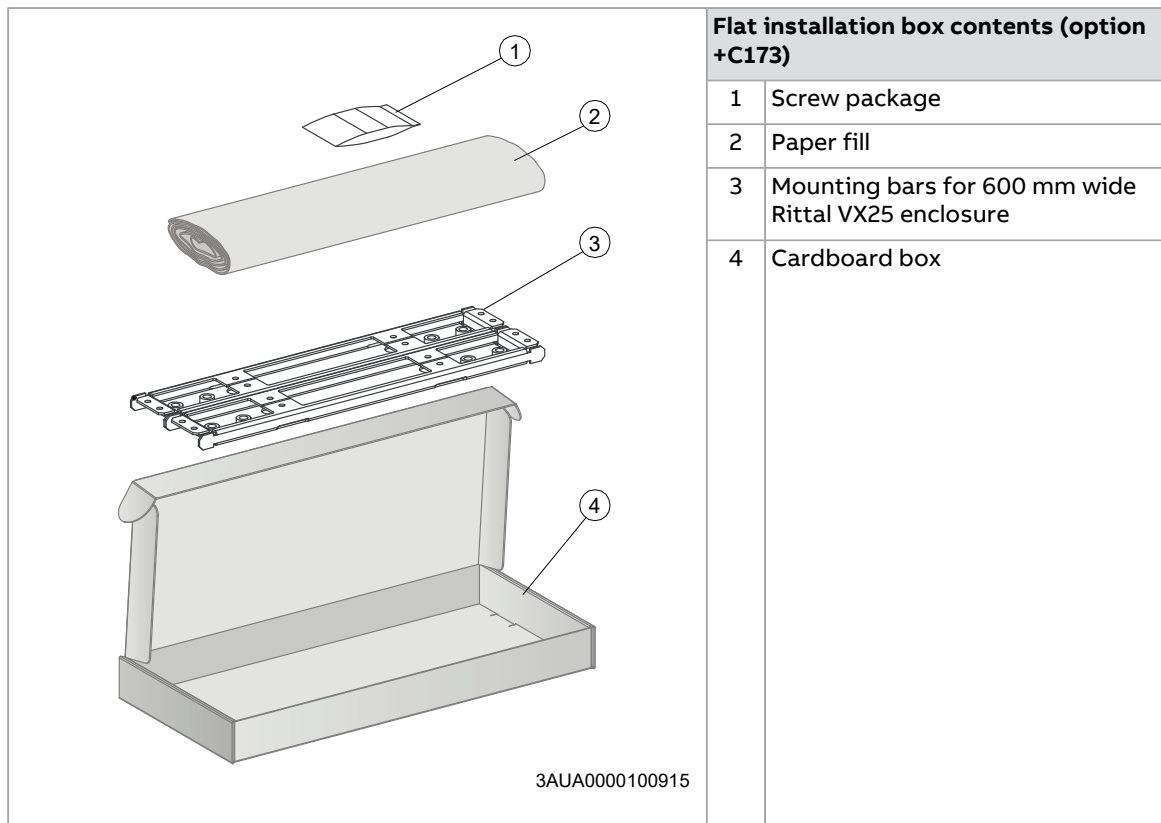

■ Examining the delivery

Examine that all the items are present and there are no signs of damage. Read the data on the type designation label of the drive module to make sure that the module is of the correct type.

■ Lifting the drive module

Lift the drive module only by the lifting lugs.

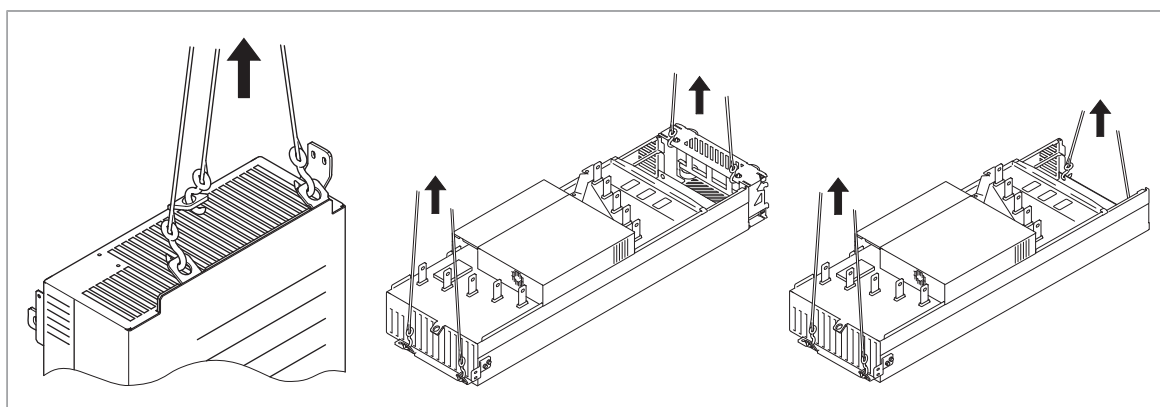

Installation alternatives

You can install the drive module into a cabinet using different procedures depending on the drive configuration. Obey the general power and control cable installation instructions in this chapter and see the installation example of your drive configuration in the following chapters.

■ Standard drive module configuration (bookshelf mounting)

For an installation example on how to install the drive module with clear plastic shrouds into a Rittal VX25 enclosure, see [Installation example 1 - Bookshelf installation in a 600 mm enclosure \(page 131\)](#). See also [ACS880-04 drive modules \(200 to 710 kW, 300 to 700 hp\) quick installation guide \(3AXD50000009366 \[English\]\)](#).

■ Drive module configuration for flat mounting (option +C173)

You can attach the drive module to the cabinet mounting plate in flat position

- with bolts through the mounting holes at the top and bottom of the module,
- or you can, first, attach the mounting brackets delivered with option +C173 to the cabinet mounting plate and then attach the drive module to the mounting brackets with screws.

See the dimension drawing for [R10 with options +0B051+C173+E208+H356+0H354+0H371 \(page 214\)](#) or for [R11 with options +0B051+C173+E208+H356+0H354+0H371 \(page 223\)](#).

Note: For option +0H354 (low pedestal): Make sure that the cabinet mounting plate and frame are strong enough to carry the weight of the drive module. See section [Dimensions, weights and free space requirements \(page 193\)](#).

For an installation example on how to install the drive module without wheeled pedestal in flat position in a Rittal VX25 enclosure, see [Step-by-step drawings for a flat installation example in a Rittal VX25 600 mm wide enclosure \(page 269\)](#).

■ Optional input power cable connection terminals and ground busbar assembly (+H370)

Connect the input power cable connection terminals as shown in [Step-by-step drawings for an installation example of standard drive configuration with option +E208 in Rittal VX25 600 mm wide enclosure \(page 261\)](#).

Install the metallic shroud with ground bar as shown below.



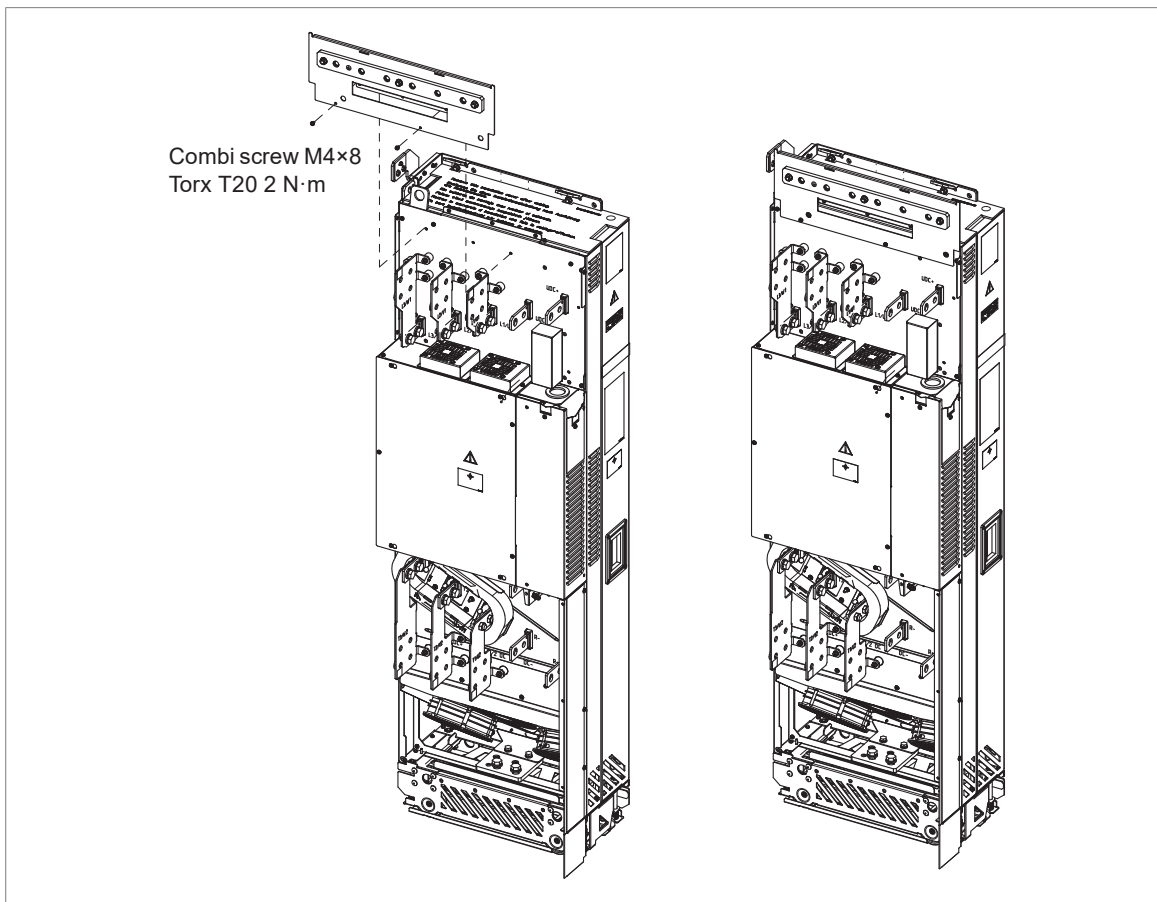

■ Drive module with full cabling panels (option +H381)

For an installation example of the drive module with full cabling panels (option +H381) into a Rittal VX25 enclosure including power cable connection procedure, see [Installation example 2 - Bookshelf installation in a 400 mm enclosure \(page 139\)](#).

Note: This installation alternative is not possible without wheeled pedestal (with option +0H354).

■ Drive module without full-size output cable connection terminals (option +0H371) and IP20 shrouds (option +0B051)

The power cables can be connected directly to the drive module input and output terminals with cable lugs or by busbars. The drive module can also be installed self standing on the floor in an electrical equipment room when the power cable terminals and electrical parts are protected against contact and the drive module is grounded correctly.

■ Drive module configuration with power cable connection terminals on the right-hand side of the drive module (option +H391)

For an installation example of the drive module with option +H391 into a Rittal VX25 enclosure, see [Step-by-step drawings for option +H391 installation example in a Rittal VX25 600 mm wide enclosure \(page 271\)](#). Otherwise, install the drive module as the standard drive module configuration.

■ Drive module without wheeled pedestal (option +0H354)

The drive module without wheeled pedestal can be mounted on a wall or a cabinet with four screws through the fastening holes at the top and bottom of the module.

Make sure that the cabinet mounting plate and frame are strong enough to carry the weight of the drive module. See [Dimensions, weights and free space requirements \(page 193\)](#).

■ Attaching the drive module to a mounting plate or wall

Use the support bracket 3AUA0000096082 (included in the assembly kit 3AXD50000453900) if you attach the drive module directly to a mounting plate or wall. The support bracket prevents the drive module screws from chafing against the plate.

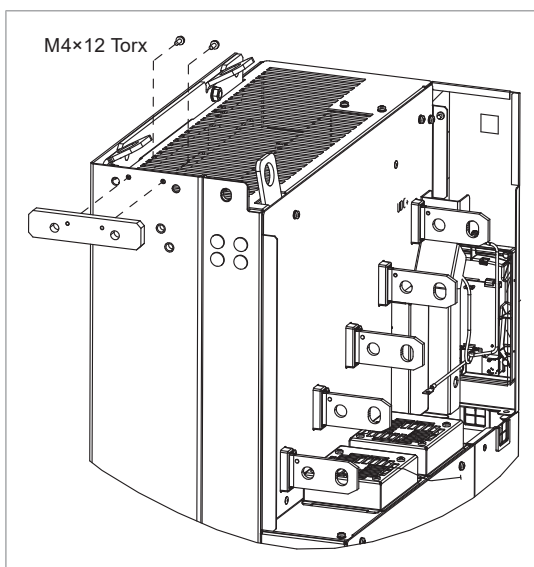

■ Attaching the drive module to a mounting plate or wall (option +H391)

See [Step-by-step drawings for option +H391 installation example in a Rittal VX25 600 mm wide enclosure \(page 271\)](#).

■ Attaching the external control unit

The drive control unit can be attached on a mounting plate through the fastening holes in its back or by using a DIN rail.



Attaching the external control unit to a mounting plate or wall

The external control unit and its mounting template are delivered in a cardboard box inside the drive module package. The mounting template contains a mounting pattern for two different control units, one on each side. Make sure to use the ZCU-14 control unit mounting pattern.

1. Mark the positions of the fastening screws to the wall through the mounting template.
2. Attach the screws.
3. Lift the control unit onto the screws and tighten the screws.

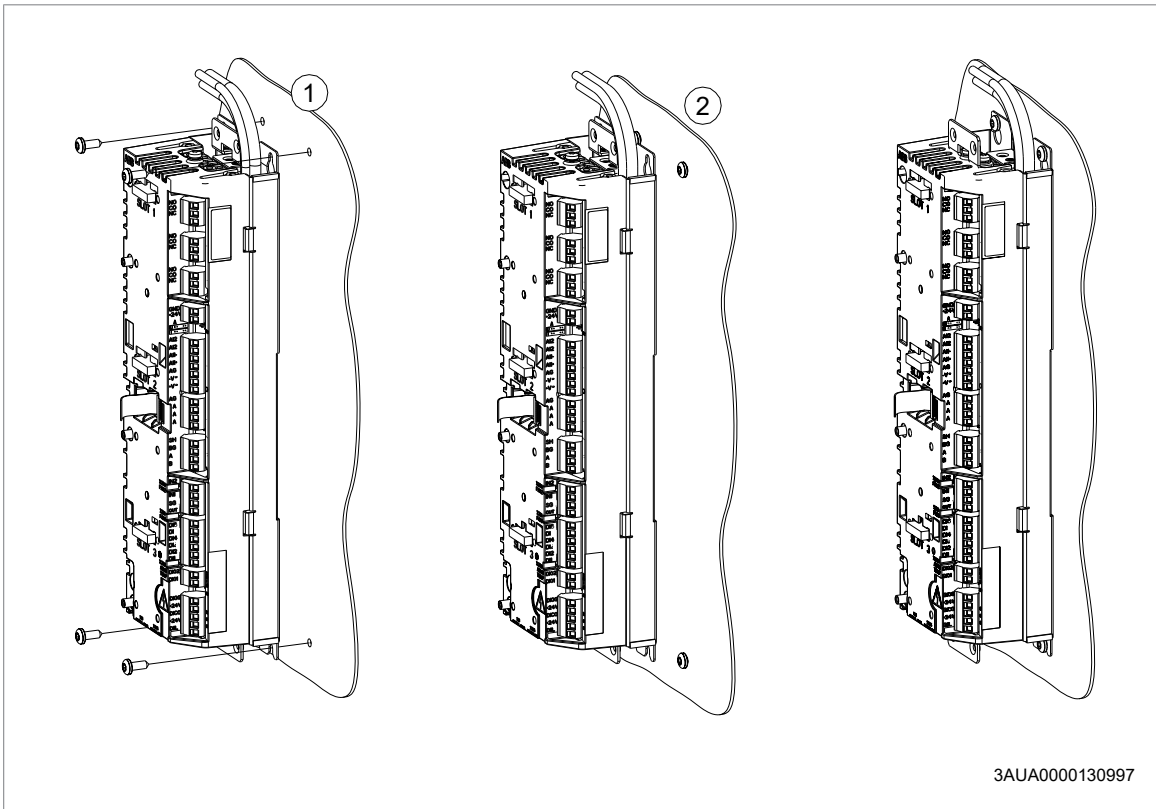

Attaching the external control unit vertically on a DIN rail

1. Attach the latch (A) to the back of the control unit with three screws.
2. Click the control unit to the rail as shown below (B).

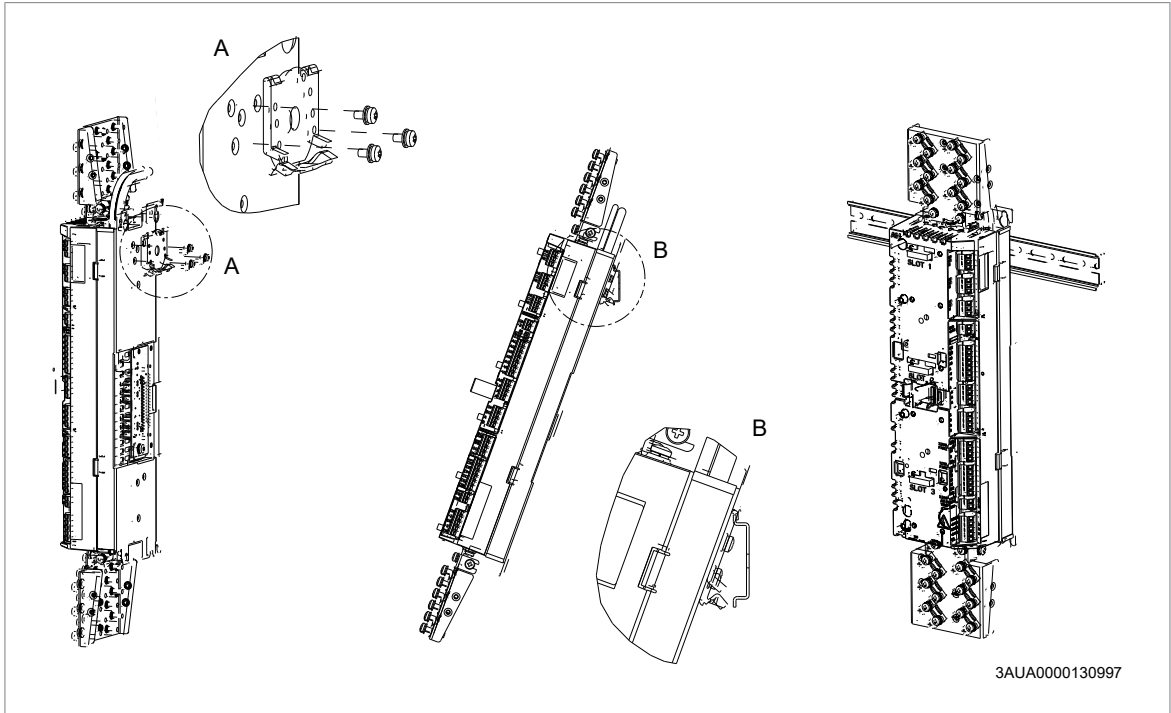

Attaching the external control unit horizontally on a DIN rail

1. Attach the latches (A) to the back of the control unit with three screws.
2. Click the control unit to the rail as shown below (B).

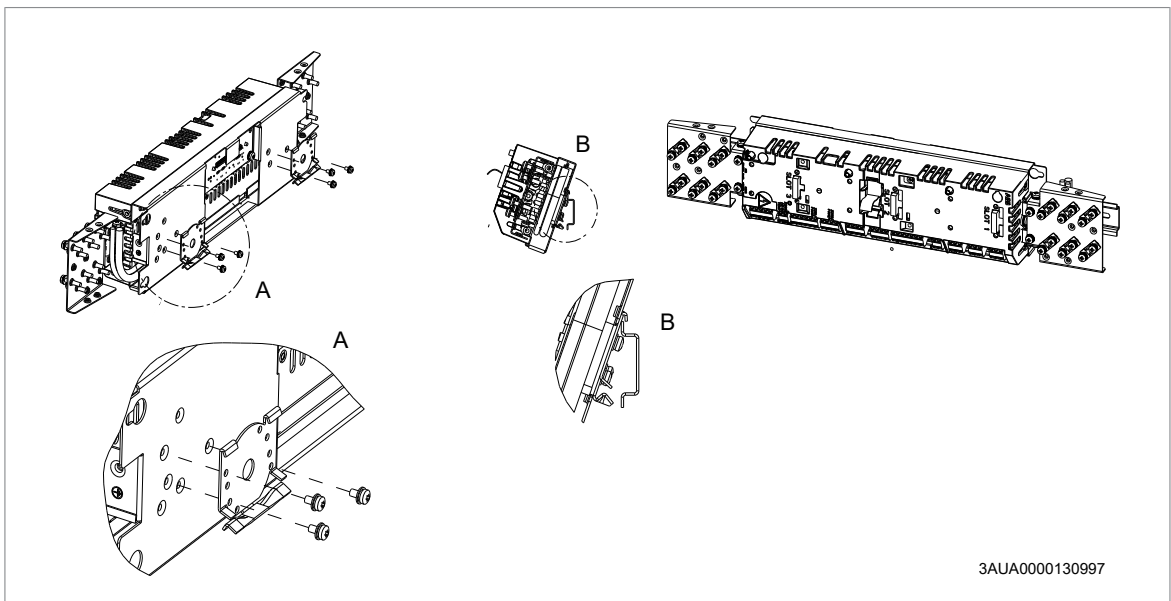

■ Alternatives for grounding the drive module

You can ground the drive module from its top back to the cabinet frame with these alternatives:

1. from the grounding hole
2. to a Rittal punched section with the fastening bracket.

70 Mechanical installation

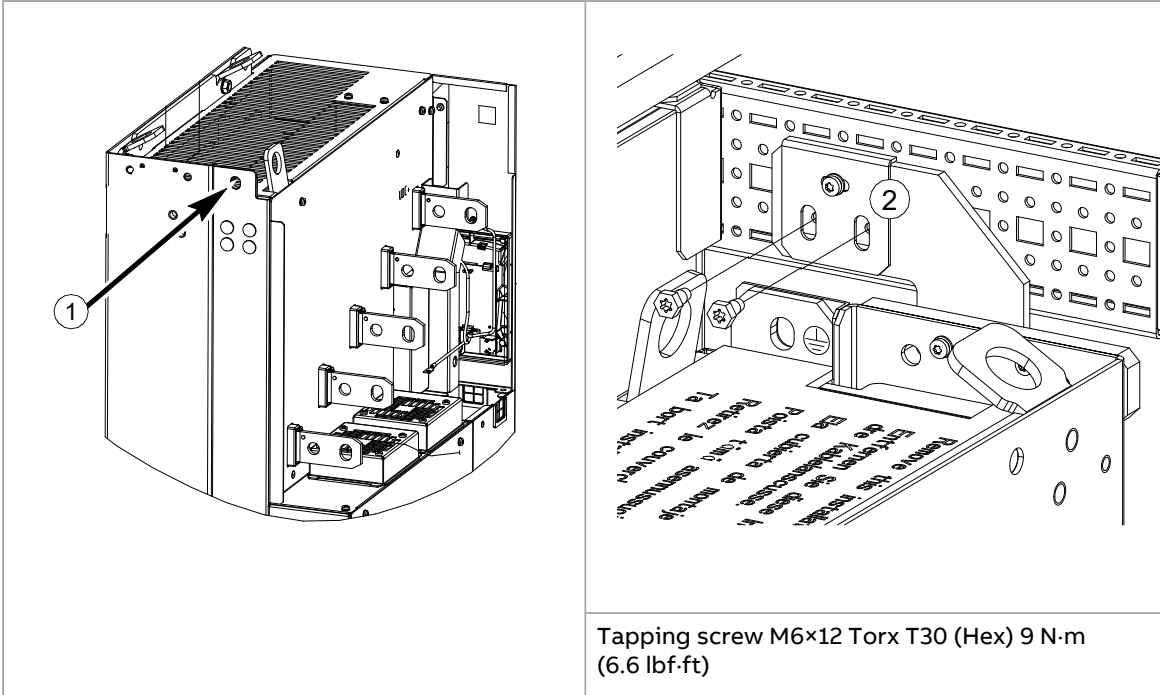

■ **Installing the bottom grille for IP20 degree of protection**

If IP20 degree of protection is needed from the bottom side, install the bottom grille as shown below.

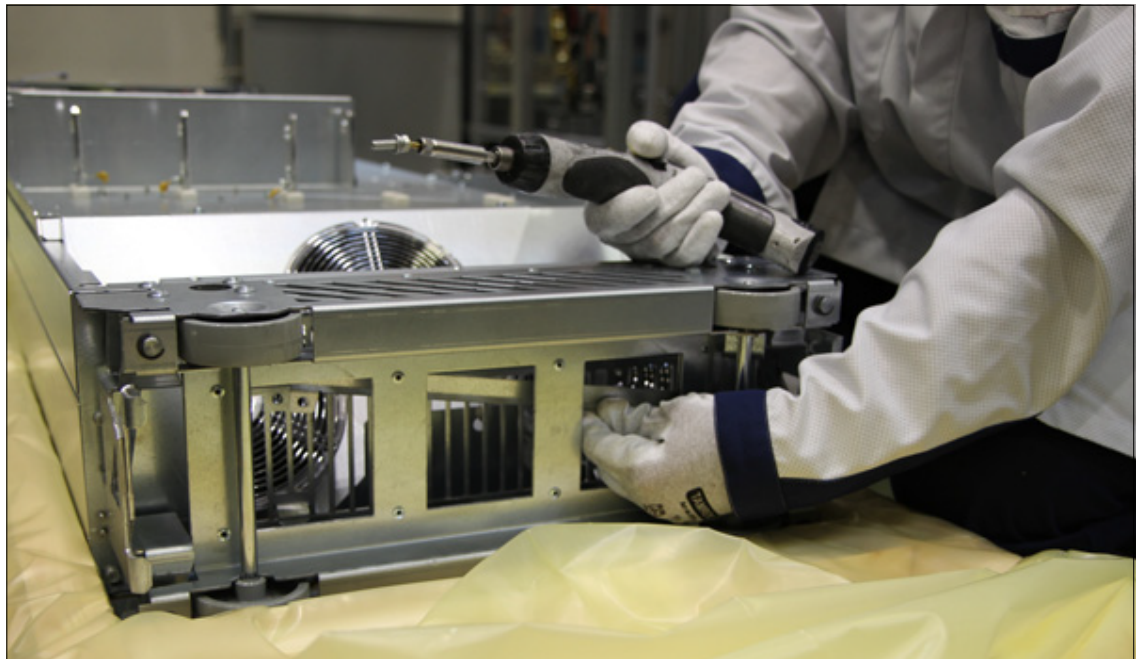
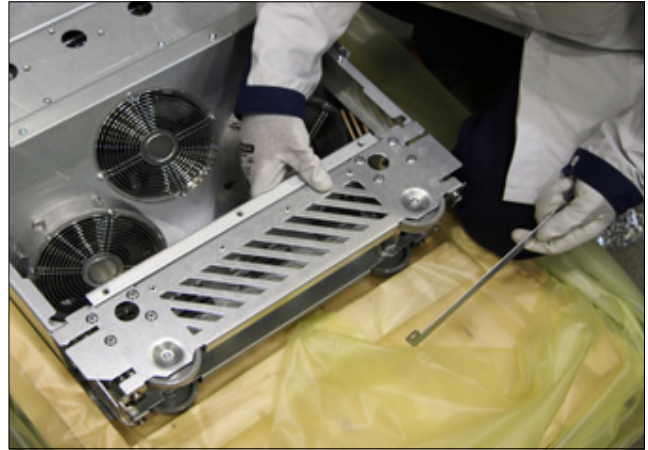

6

Guidelines for planning the electrical installation

Contents of this chapter

This chapter contains guidelines for planning the electrical installation of the drive.

Limitation of liability

The installation must always be designed and made according to applicable local laws and regulations. ABB does not assume any liability whatsoever for any installation which breaches the local laws and/or other regulations. Furthermore, if the recommendations given by ABB are not followed, the drive may experience problems that the warranty does not cover.

■ North America

Installations must be compliant with NFPA 70 (NEC)¹⁾ and/or Canadian Electrical Code (CE) along with state and local codes for your location and application.

¹⁾ National Fire Protection Association 70 (National Electric Code).

Selecting the main supply disconnecting device

You must equip the drive with a main supply disconnecting device which meets the local safety regulations. You must be able to lock the disconnecting device to the open position for installation and maintenance work.

To comply with European Union directives and United Kingdom regulations related to standard EN 60204-1, the disconnecting device must be one of these types:

- switch-disconnector of utilization category AC-23B (IEC 60947-3)
- disconnector that has an auxiliary contact that in all cases causes switching devices to break the load circuit before the opening of the main contacts of the disconnector (EN 60947-3)
- circuit-breaker suitable for isolation in accordance with IEC 60947-2.

Selecting the main contactor

You can equip the drive with a main contactor.

Follow these guidelines when you select a customer-defined main contactor:

- Dimension the contactor according to the nominal voltage and current of the drive. Also consider the environmental conditions such as surrounding air temperature.
- IEC installations: Select contactor with utilization category AC-1 (number of operations under load) according to IEC 60947-4.
- Consider the application life time requirements.

Examining the compatibility of the motor and drive

Use asynchronous AC induction motors, permanent magnet synchronous motors, AC induction servomotors or ABB synchronous reluctance motors (SynRM motors) with the drive.

Select the motor size and drive type from the rating table on basis of the AC line voltage and motor load. You can find the rating table in the appropriate hardware manual. You can also use the DriveSize PC tool.

Make sure that the motor can be used with an AC drive. See [Requirements tables \(page 75\)](#). For basics of protecting the motor insulation and bearings in drive systems, see [Protecting the motor insulation and bearings \(page 74\)](#).

Note:

- Consult the motor manufacturer before using a motor with nominal voltage that differs from the AC line voltage connected to the drive input.
- The voltage peaks at the motor terminals are relative to the supply voltage of the drive, not to the drive output voltage.

■ Protecting the motor insulation and bearings

The drive employs modern IGBT inverter technology. Regardless of frequency, the drive output comprises pulses of approximately the drive DC bus voltage with a very short rise time. The pulse voltage can almost double at the motor terminals, depending on the attenuation and reflection properties of the motor cable and the terminals. This can cause additional stress on the motor and motor cable insulation.

Modern variable speed drives with their fast rising voltage pulses and high switching frequencies can generate current pulses that flow through the motor bearings. This can gradually erode the bearing races and rolling elements.

du/dt filters protect motor insulation system and reduce bearing currents. Common mode filters mainly reduce bearing currents. Insulated N-end (non-drive end) bearings protect the motor bearings.

■ Requirements tables

These tables show how to select the motor insulation system and when a drive du/dt and common mode filters and insulated N-end (non-drive end) motor bearings are required. Ignoring the requirements or improper installation may shorten motor life or damage the motor bearings and voids the warranty.

Requirements for ABB motors, $P_n < 100$ kW (134 hp)

See also [Abbreviations \(page 78\)](#).

Motor type	Nominal AC line voltage	Requirement for	
		Motor insulation system	ABB du/dt and common mode filters, insulated N-end motor bearings
			$P_n < 100$ kW and frame size < IEC 315 $P_n < 134$ hp and frame size < NEMA 500
Random-wound M2_, M3_ and M4_	$U_n \leq 500$ V	Standard	-
	500 V < $U_n \leq 600$ V	Standard	+ du/dt
		Reinforced	-
	600 V < $U_n \leq 690$ V	Reinforced (+405 special insulation)	_1)
Form-wound HX_ and AM_	380 V < $U_n \leq 690$ V	Standard	N/A
Old ²⁾ form-wound HX_ and modular	380 V < $U_n \leq 690$ V	Check with the motor manufacturer.	+ N + du/dt with voltages over 500 V + CMF
Random-wound HX_ and AM_ ³⁾	0 V < $U_n \leq 500$ V	Enamelled wire with fiber glass taping	+ N + CMF
	500 V < $U_n \leq 690$ V		+ N + du/dt + CMF
HDP	Consult the motor manufacturer.		

¹⁾ Not applicable to motors for explosive atmospheres. Refer to Low voltage Motors for explosive atmospheres catalog.

²⁾ manufactured before 1.1.1998

³⁾ For motors manufactured before 1.1.1998, check for additional instructions with the motor manufacturer.

Requirements for ABB motors, $P_n \geq 100$ kW (134 hp)See also [Abbreviations \(page 78\)](#).

Motor type	Nominal AC line voltage	Motor insulation system	Requirement for	
			ABB du/dt and common mode filters, insulated N-end motor bearings	
			$100 \text{ kW} \leq P_n < 350 \text{ kW}$ or $IEC 315 \leq \text{frame size} < IEC 400$	$P_n \geq 350 \text{ kW}$ or $\text{frame size} \geq IEC 400$
			$134 \text{ hp} \leq P_n < 469 \text{ hp}$ or $NEMA 500 \leq \text{frame size} \leq NEMA 580$	$P_n \geq 469 \text{ hp}$ or $\text{frame size} > NEMA 580$
Random-wound M2_, M3_ and M4_	$U_n \leq 500 \text{ V}$	Standard	+ N	+ N + CMF
	$500 \text{ V} < U_n \leq 600 \text{ V}$	Standard	+ N + du/dt	+ N + du/dt + CMF
		Reinforced	+ N	+ N + CMF
$600 \text{ V} < U_n \leq 690 \text{ V}$	Reinforced (+405 special insulation)	+ N ¹⁾	+ N + CMF ¹⁾	
Form-wound HX_ and AM_	$380 \text{ V} < U_n \leq 690 \text{ V}$	Standard	+ N + CMF	$P_n < 500 \text{ kW}$: + N + CMF
				$P_n \geq 500 \text{ kW}$: + N + du/dt + CMF
Old ²⁾ form-wound HX_ and modular	$380 \text{ V} < U_n \leq 690 \text{ V}$	Check with the motor manufacturer.	+ N + du/dt with voltages over 500 V + CMF	
Random-wound HX_ and AM_ ³⁾	$0 \text{ V} < U_n \leq 500 \text{ V}$	Enamelled wire with fiber glass taping	+ N + CMF	
	$500 \text{ V} < U_n \leq 690 \text{ V}$		+ N + du/dt + CMF	
HDP	Consult the motor manufacturer.			

¹⁾ Not applicable to motors for explosive atmospheres. Refer to Low voltage Motors for explosive atmospheres catalog.

²⁾ manufactured before 1.1.1998

³⁾ For motors manufactured before 1.1.1998, check for additional instructions with the motor manufacturer.

Requirements for non-ABB motors, $P_n < 100$ kW (134 hp)See also [Abbreviations \(page 78\)](#).

Motor type	Nominal AC line voltage	Motor insulation system	Requirement for
			ABB du/dt and common mode filters, insulated N-end motor bearings
			$P_n < 100$ kW and frame size < IEC 315
			$P_n < 134$ hp and frame size < NEMA 500
Random-wound and form-wound	$U_n \leq 420$ V	Standard: $\hat{U}_{LL} = 1300$ V	-
	420 V < $U_n \leq 500$ V	Standard: $\hat{U}_{LL} = 1300$ V	+ du/dt
		Reinforced: $\hat{U}_{LL} = 1600$ V, 0.2 μ s rise time	-
	500 V < $U_n \leq 600$ V	Reinforced: $\hat{U}_{LL} = 1600$ V	+ du/dt
		Reinforced: $\hat{U}_{LL} = 1800$ V	-
	600 V < $U_n \leq 690$ V	Reinforced: $\hat{U}_{LL} = 1800$ V	+ du/dt
		Reinforced: $\hat{U}_{LL} = 2000$ V, 0.3 μ s rise time ¹⁾	-

¹⁾ If the intermediate DC circuit voltage of the drive is increased from the nominal level due to long term resistor braking cycles, check with the motor manufacturer if additional output filters are needed.

Requirements for non-ABB motors, $P_n \geq 100$ kW (134 hp)See also [Abbreviations \(page 78\)](#).

Motor type	Nominal AC line voltage	Motor insulation system	Requirement for	
			ABB du/dt and common mode filters, insulated N-end motor bearings	
			$100 \text{ kW} \leq P_n < 350 \text{ kW}$ or $\text{IEC } 315 \leq \text{frame size} < \text{IEC } 400$	$P_n \geq 350 \text{ kW}$ or $\text{frame size} \geq \text{IEC } 400$
			$134 \text{ hp} \leq P_n < 469 \text{ hp}$ or $\text{NEMA } 500 \leq \text{frame size} \leq \text{NEMA } 580$	$P_n \geq 469 \text{ hp}$ or $\text{frame size} > \text{NEMA } 580$
Random-wound and form-wound	$U_n \leq 420 \text{ V}$	Standard: $\hat{U}_{LL} = 1300 \text{ V}$	+ N or CMF	+ N + CMF
	$420 \text{ V} < U_n \leq 500 \text{ V}$	Standard: $\hat{U}_{LL} = 1300 \text{ V}$	+ du/dt + (N or CMF)	+ N + du/dt + CMF
		Reinforced: $\hat{U}_{LL} = 1600 \text{ V}$, 0.2 μs rise time	+ N or CMF	+ N + CMF
	$500 \text{ V} < U_n \leq 600 \text{ V}$	Reinforced: $\hat{U}_{LL} = 1600 \text{ V}$	+ du/dt + (N or CMF)	+ N + du/dt + CMF
		Reinforced: $\hat{U}_{LL} = 1800 \text{ V}$	+ N or CMF	+ N + CMF
	$600 \text{ V} < U_n \leq 690 \text{ V}$	Reinforced: $\hat{U}_{LL} = 1800 \text{ V}$	+ du/dt + N	+ N + du/dt + CMF
		Reinforced: $\hat{U}_{LL} = 2000 \text{ V}$, 0.3 μs rise time ¹⁾	+ N + CMF	+ N + CMF

¹⁾ If the intermediate DC circuit voltage of the drive is increased from the nominal level due to long term resistor braking cycles, check with the motor manufacturer if additional output filters are needed.

Abbreviations

Abbr.	Definition
U_n	Nominal AC line voltage
\hat{U}_{LL}	Peak line-to-line voltage at motor terminals which the motor insulation must withstand
P_n	Motor nominal power
du/dt	du/dt filter at the output of the drive
CMF	Common mode filter of the drive
N	N-end bearing: insulated motor non-drive end bearing
n.a.	Motors of this power range are not available as standard units. Consult the motor manufacturer.

Availability of du/dt filter and common mode filter by drive type

Product type	Availability of du/dt filter	Availability of common mode filter (CMF)
ACS880-04	Ordered separately, see du/dt filters (page 259)	+E208

Additional requirements for explosion-safe (EX) motors

If you use an explosion-safe (EX) motor, obey the rules in the requirements table above. In addition, consult the motor manufacturer for any further requirements.

Additional requirements for ABB motors of types other than M2_, M3_, M4_, HX_ and AM_

Use the selection criteria given for non-ABB motors.

Additional requirements for braking applications

When the motor brakes the machinery, the intermediate circuit DC voltage of the drive increases, the effect being similar to the motor supply voltage increasing by up to 20 percent. Consider this voltage increase when specifying the motor insulation requirements if the motor will be braking a large part of its operation time.

Example: Motor insulation requirement for a 400 V AC line voltage application must be selected as if the drive were supplied with 480 V.

Additional requirements for ABB high-output and IP23 motors

The rated output power of high output motors is higher than what is stated for the particular frame size in EN 50347 (2001).

This table shows the requirements for protecting the motor insulation and bearings in drive systems for ABB random-wound motor series (for example, M3AA, M3AP and M3BP).

Nominal AC supply voltage	Requirement for			
	Motor insulation system	ABB du/dt and common mode filters, insulated N-end motor bearings		
		$P_n < 100 \text{ kW}$	$100 \text{ kW} \leq P_n < 200 \text{ kW}$	$P_n \geq 200 \text{ kW}$
		$P_n < 140 \text{ hp}$	$140 \text{ hp} \leq P_n < 268 \text{ hp}$	$P_n \geq 268 \text{ hp}$
$U_n \leq 500 \text{ V}$	Standard	-	+ N	+ N + CMF
$500 \text{ V} < U_n \leq 600 \text{ V}$	Standard	+ du/dt	+ du/dt + N	+ du/dt + N + CMF
	Reinforced	-	+ N	+ N + CMF
$600 \text{ V} < U_n \leq 690 \text{ V}$	Reinforced	+ du/dt	+ du/dt + N	+ du/dt + N + CMF

Additional requirements for non-ABB high-output and IP23 motors

The rated output power of high-output motors is higher than what is stated for the particular frame size in EN 50347 (2001).

If you plan to use a non-ABB high-output motor or an IP23 motor, consider these additional requirements for protecting the motor insulation and bearings in drive systems:

80 Guidelines for planning the electrical installation

- If motor power is below 350 kW: Equip the drive and/or motor with the filters and/or bearings according to the table below.
- If motor power is above 350 kW: Consult the motor manufacturer.

Nominal AC supply voltage	Requirement for		
	Motor insulation system	ABB du/dt and common mode filters, insulated N-end motor bearings	
		$P_n < 100 \text{ kW}$ or frame size < IEC 315	$100 \text{ kW} < P_n < 350 \text{ kW}$ or IEC 315 < frame size < IEC 400
	$P_n < 134 \text{ hp}$ or frame size < NEMA 500	$134 \text{ hp} < P_n < 469 \text{ hp}$ or NEMA 500 < frame size < NEMA 580	
$U_n \leq 420 \text{ V}$	Standard: $\hat{U}_{LL} = 1300 \text{ V}$	+ N or CMF	+ N or CMF
$420 \text{ V} < U_n < 500 \text{ V}$	Standard: $\hat{U}_{LL} = 1300 \text{ V}$	+ du/dt + (N or CMF)	+ N + du/dt + CMF
	Reinforced: $\hat{U}_{LL} = 1600 \text{ V}$, 0.2 microsecond rise time	+ N or CMF	+ N or CMF
$500 \text{ V} < U_n \leq 600 \text{ V}$	Reinforced: $\hat{U}_{LL} = 1600 \text{ V}$	+ du/dt + (N or CMF)	+ N + du/dt + CMF
	Reinforced: $\hat{U}_{LL} = 1800 \text{ V}$	+ N or CMF	+ N + CMF
$600 \text{ V} < U_n \leq 690 \text{ V}$	Reinforced: $\hat{U}_{LL} = 1800 \text{ V}$	+ N + du/dt	+ N + du/dt + CMF
	Reinforced: $\hat{U}_{LL} = 2000 \text{ V}$, 0.3 microsecond rise time ¹⁾	+ N + CMF	+ N + CMF

¹⁾ If the intermediate DC circuit voltage of the drive is increased from the nominal level due to long term resistor braking cycles, check with the motor manufacturer if additional output filters are needed.

Additional data for calculating the rise time and the peak line-to-line voltage

The diagrams below show the relative peak line-to-line voltage and rate of change of voltage as a function of the motor cable length. If you need to calculate the actual peak voltage and voltage rise time considering the actual cable length, proceed as follows:

- Peak line-to-line voltage: Read the relative \hat{U}_{LL}/U_n value from the diagram below and multiply it by the nominal supply voltage (U_n).
- Voltage rise time: Read the relative values \hat{U}_{LL}/U_n and $(du/dt)/U_n$ from the diagram below. Multiply the values by the nominal supply voltage (U_n) and substitute into equation $t = 0.8 \cdot \hat{U}_{LL}/(du/dt)$.

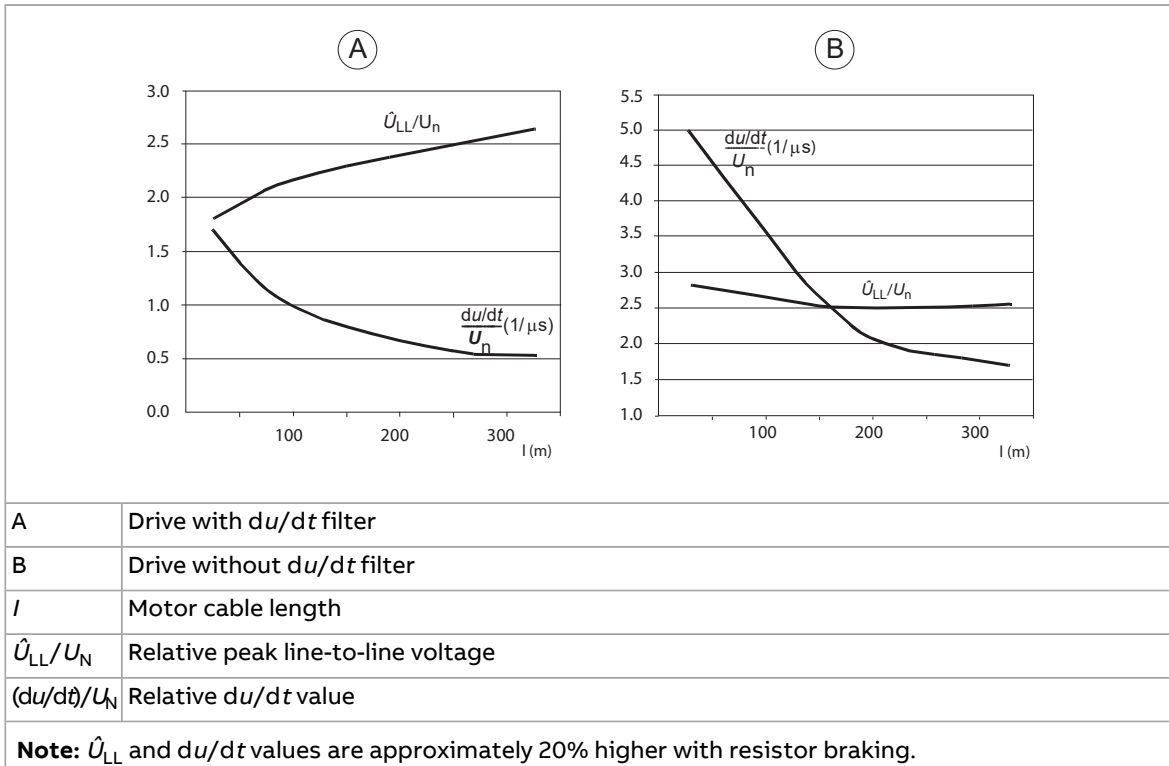

Additional note for sine filters

A sine filter also protects the motor insulation system. The peak phase-to-phase voltage with a sine filter is approximately $1.5 \cdot U_n$.

Selecting the power cables

■ General guidelines

Select the input power and motor cables according to local regulations.

- **Current:** Select a cable capable of carrying the maximum load current and suitable for the prospective short-circuit current provided by the supply network. The method of installation and ambient temperature affect the cable current carrying capacity. Obey local regulations and laws.
- **Temperature:** For an IEC installation, select a cable rated for at least 70 °C (158 °F) maximum permissible temperature of conductor in continuous use. For North America, select a cable rated for at least 75 °C (167 °F).
Important: For certain product types or option configurations higher temperature rating may be required. See the technical data for details.
- **Voltage:** 600 V AC cable is accepted for up to 500 V AC. 750 V AC cable is accepted for up to 600 V AC. 1000 V AC cable is accepted for up to 690 V AC.

To comply with the EMC requirements of the CE mark, use one of the preferred cable types. See [Preferred power cable types \(page 82\)](#).

Symmetrical shielded cable reduces electromagnetic emission of the whole drive system as well as the stress on motor insulation, bearing currents and wear.

Metal conduit reduces electromagnetic emission of the whole drive system.

■ **Typical power cable sizes**

See the technical data in the appropriate hardware manual.

■ **Power cable types**

Preferred power cable types

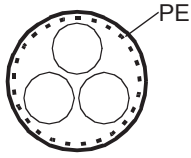
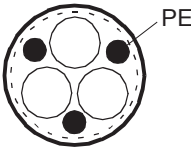
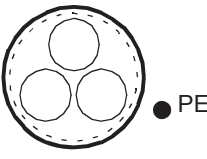

This section shows the preferred cable types. Make sure that the selected cable type also complies with local/state/country electrical codes.

Cable type	Use as input power cabling	Use as motor cabling and as brake resistor cabling
 <p>Symmetrical shielded (or armored) cable with three phase conductors and concentric PE conductor as shield (or armor)</p>	Yes	Yes
 <p>Symmetrical shielded (or armored) cable with three phase conductors and symmetrically constructed PE conductor and a shield (or armor)</p>	Yes	Yes
 <p>Symmetrical shielded (or armored) cable with three phase conductors and a shield (or armor), and separate PE conductor/cable¹⁾</p>	Yes	Yes

¹⁾ A separate PE conductor is required if the conductivity of the shield (or armor) is not sufficient for the PE use.

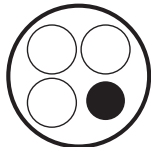
Alternate power cable types

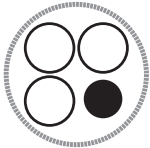
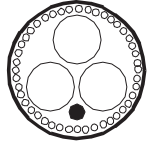
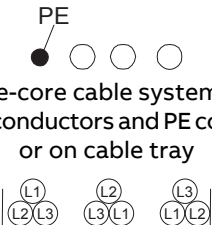
Cable type	Use as input power cabling	Use as motor cabling and as brake resistor cabling
 <p>Four-conductor cable in plastic jacket (three phase conductors and PE)</p>	Yes with phase conductor smaller than 10 mm ² (8 AWG) Cu.	Yes with phase conductor smaller than 10 mm ² (8 AWG) Cu, or motors up to 30 kW (40 hp). Note: Shielded or armored cable, or cabling in metal conduit is always recommended to minimize radio frequency interference.

Cable type	Use as input power cabling	Use as motor cabling and as brake resistor cabling
 <p>Four-conductor armored cable (three phase conductors and PE)</p>	Yes	Yes with phase conductor smaller than 10 mm ² (8 AWG) Cu, or motors up to 30 kW (40 hp)
 <p>Shielded (Al/Cu shield or armor)¹⁾ four-conductor cable (three phase conductors and a PE)</p>	Yes	Yes with motors up to 100 kW (135 hp). A potential equalization between the frames of motor and driven equipment is required.
 <p>A single-core cable system: three phase conductors and PE conductor on cable tray</p> <p>Preferable cable arrangement to avoid voltage or current imbalance between the phases</p>	Yes  WARNING If you use unshielded single-core cables in an IT network, make sure that the non-conductive outer sheath (jacket) of the cables have good contact with a properly grounded conductive surface. For example, install the cables on a properly grounded cable tray. Otherwise voltage may become present on the non-conductive outer sheath of the cables, and there is even a risk of an electric shock.	No

¹⁾ Armor may act as an EMC shield, as long as it provides the same performance as a concentric EMC shield of a shielded cable. To be effective at high frequencies, the shield conductivity must be at least 1/10 of the phase conductor conductivity. The effectiveness of the shield can be evaluated based on the shield inductance, which must be low and only slightly dependent on frequency. The requirements are easily met with a copper or aluminum shield/armor. The cross-section of a steel shield must be ample and the shield helix must have a low gradient. A galvanized steel shield has a better high-frequency conductivity than a non-galvanized steel shield.

Not allowed power cable types

Cable type	Use as input power cabling	Use as motor cabling and as brake resistor cabling
 <p>Symmetrical shielded cable with individual shields for each phase conductor</p>	No	No

■ **Additional guidelines – North America**

ABB recommends the use of metallic conduit for power wiring. ABB also recommends the use of symmetrical shielded VFD cable between drive and motor(s).

This table shows examples of methods for wiring the drive. Refer to NFPA 70 (NEC) along with state and local codes for the appropriate methods for your application.

Wiring method	Notes
Conduit - Metallic ^{1) 2)}	
Electrical metallic tubing: Type EMT	Prefer symmetrical shielded VFD cable. Use separate conduit run for each motor. Do not run input power wiring and motor wiring in the same conduit.
Rigid metal conduit: Type RMC	
Liquid-tight flexible metal electrical conduit: Type LFMC	
Conduit - Non-metallic ^{2) 3)}	
Liquid-tight flexible non-metallic conduit: Type LFNC	Prefer symmetrical shielded VFD cable. Use separate conduit run for each motor. Do not run input power wiring and motor wiring in the same conduit.
Wireways ²⁾	
Metallic	Prefer symmetrical shielded VFD cable. Separate motor wiring from input power wiring and other low voltage wiring. Do not run outputs of multiple drives parallel. Bundle each cable (wiring) together and use separators where possible.
Free air ²⁾	
Enclosures, air handlers, etc.	Prefer symmetrical shielded VFD cable. Allowed internally in enclosures when in accordance with UL.

¹⁾ Metallic conduit may be used as an additional ground path, provided this path is a solid path capable of handling ground currents.

²⁾ See NFPA 70 (NEC), UL, and local codes for your application.

³⁾ Non-metallic conduit use underground is allowed; however, these installations inherently have an increased chance for nuisance problems due to the potential for water/moisture in the conduit. Water/moisture in the conduit increases the likelihood of VFD faults or warnings. Proper installation is required to make sure there is no intrusion of water/moisture.

Metal conduit

Couple separate parts of a metal conduit together: bridge the joints with a ground conductor bonded to the conduit on each side of the joint. Also bond the conduits to the drive enclosure and motor frame. Use separate conduits for input power, motor, brake resistor, and control wiring. Do not run motor wiring from more than one drive in the same conduit.

■ Power cable shield

If the cable shield is used as the sole protective earth (PE) conductor, make sure that its conductivity agrees with the PE conductor requirements.

To effectively suppress radiated and conducted radio-frequency emissions, the cable shield conductivity must be at least 1/10 of the phase conductor conductivity. The requirements are easily met with a copper or aluminum shield. The minimum requirement of the motor cable shield of the drive is shown below. It consists of a concentric layer of copper wires with an open helix of copper tape or copper wire. The better and tighter the shield, the lower the emission level and bearing currents.

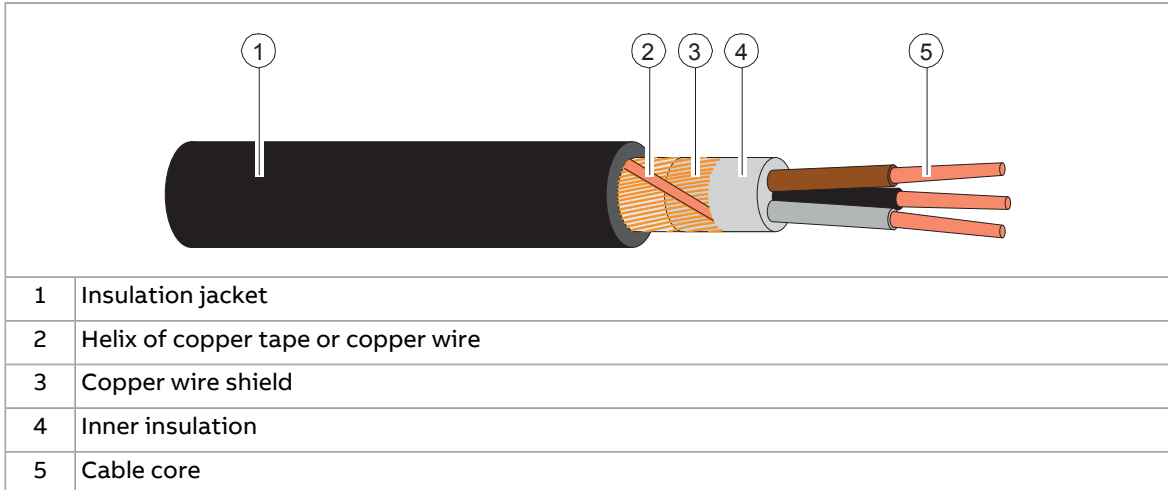

Grounding requirements

This section gives general requirements for grounding the drive. When you plan the grounding of the drive, obey all the applicable national and local regulations.

The conductivity of the protective earth conductor(s) must be sufficient.

Unless local wiring regulations state otherwise, the cross-sectional area of the protective earth conductor must agree with the conditions that require automatic disconnection of the supply required in 411.3.2 of IEC 60364-4-41:2005 and be capable of withstanding the prospective fault current during the disconnection time of the protective device. The cross-sectional area of the protective earth conductor must be selected from the table below or calculated according to 543.1 of IEC 60364-5-54.

The table shows the minimum cross-sectional area of the protective earth conductor related to the phase conductor size according to IEC/UL 61800-5-1 when the phase conductor(s) and the protective earth conductor are made of the same metal. If they are different metals, the cross-sectional area of the protective earth conductor must be determined in a manner which produces a conductance equivalent to that which results from the application of this table.

Cross-sectional area of the phase conductors S (mm ²)	Minimum cross-sectional area of the corresponding protective earth conductor S_p (mm ²)
$S \leq 16$	S ¹⁾
$16 < S \leq 35$	16
$35 < S$	$S/2$

¹⁾ For the minimum conductor size in IEC installations, refer to [Additional grounding requirements – IEC \(page 86\)](#).

If the protective earth conductor is not part of the input power cable or input power cable enclosure, the minimum permitted cross-sectional area is:

- 2.5 mm² if the conductor is mechanically protected,
or
- 4 mm² if the conductor is not mechanically protected. If the equipment is cord-connected, the protective earth conductor must be the last conductor to be interrupted if there is a failure in the strain relief mechanism.

■ Additional grounding requirements – IEC

This section gives grounding requirements according to standard IEC/EN 61800-5-1.

Because the normal touch current of the drive is more than 3.5 mA AC or 10 mA DC:

- the minimum size of the protective earth conductor must comply with the local safety regulations for high protective earth conductor current equipment, and
- you must use one of these connection methods:
 1. a fixed connection and:
 - a protective earth conductor with a minimum cross-sectional area of 10 mm² Cu or 16 mm² Al (as an alternative when aluminum cables are permitted),
or
 - a second protective earth conductor of the same cross-sectional area as the original protective earth conductor,
or
 - a device that automatically disconnects the supply if the protective earth conductor is damaged.
 2. a connection with an industrial connector according to IEC 60309 and a minimum protective earth conductor cross-section of 2.5 mm² as part of a multi-conductor power cable. Sufficient strain relief must be provided.

If the protective earth conductor is routed through a plug and socket, or similar means of disconnection, it must not be possible to disconnect it unless power is simultaneously removed.

Note: You can use power cable shields as protective earth conductors only when their conductivity is sufficient.

■ Additional grounding requirements – UL (NEC)

This section gives grounding requirements according to standard UL 61800-5-1.

The protective earth conductor must be sized as specified in Article 250.122 and table 250.122 of the National Electric Code, ANSI/NFPA 70.

For cord-connected equipment, it must not be possible to disconnect the protective earth conductor before power is removed.

Selecting the control cables

■ Shielding

Only use shielded control cables.

Use a double-shielded twisted pair cable for analog signals. ABB recommends this type of cable also for the pulse encoder signals. Use one individually shielded pair for each signal. Do not use common return for different analog signals.

A double-shielded cable (a) is the best alternative for low-voltage digital signals, but single-shielded (b) twisted pair cable is also acceptable.

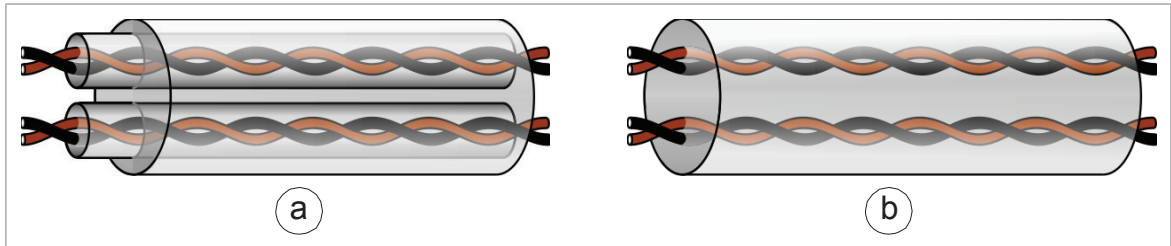

■ Signals in separate cables

Run analog and digital signals in separate, shielded cables. Do not mix 24 V DC and 115/230 V AC signals in the same cable.

■ Signals that can be run in the same cable

If their voltage does not exceed 48 V, relay-controlled signals can be run in the same cables as digital input signals. The relay-controlled signals should be run as twisted pairs.

■ Relay cable

The cable type with braided metallic shield (for example ÖLFLEX by LAPPKABEL, Germany) has been tested and approved by ABB.

■ Control panel to drive cable

Use EIA-485, Cat 5e (or better) cable with male RJ45 connectors. The maximum length of the cable is 100 m (328 ft).

■ PC tool cable

Connect the Drive Composer PC tool to the drive through the USB port of the control panel. Use a USB Type A (PC) - Type Mini-B (control panel) cable. The maximum length of the cable is 3 m (9.8 ft).

Routing the cables

■ General guidelines – IEC

- Route the motor cable away from other cables. Motor cables of several drives can be run in parallel installed next to each other.
- Install the motor cable, input power cable and control cables on separate trays.
- Avoid long parallel runs of motor cables with other cables.
- Where control cables must cross power cables, make sure that they are arranged at an angle as near to 90 degrees as possible.
- Do not run extra cables through the drive.
- Make sure that the cable trays have good electrical bonding to each other and to the grounding electrodes. Aluminum tray systems can be used to improve local equalizing of potential.

The following figure illustrates the cable routing guidelines with an example drive.

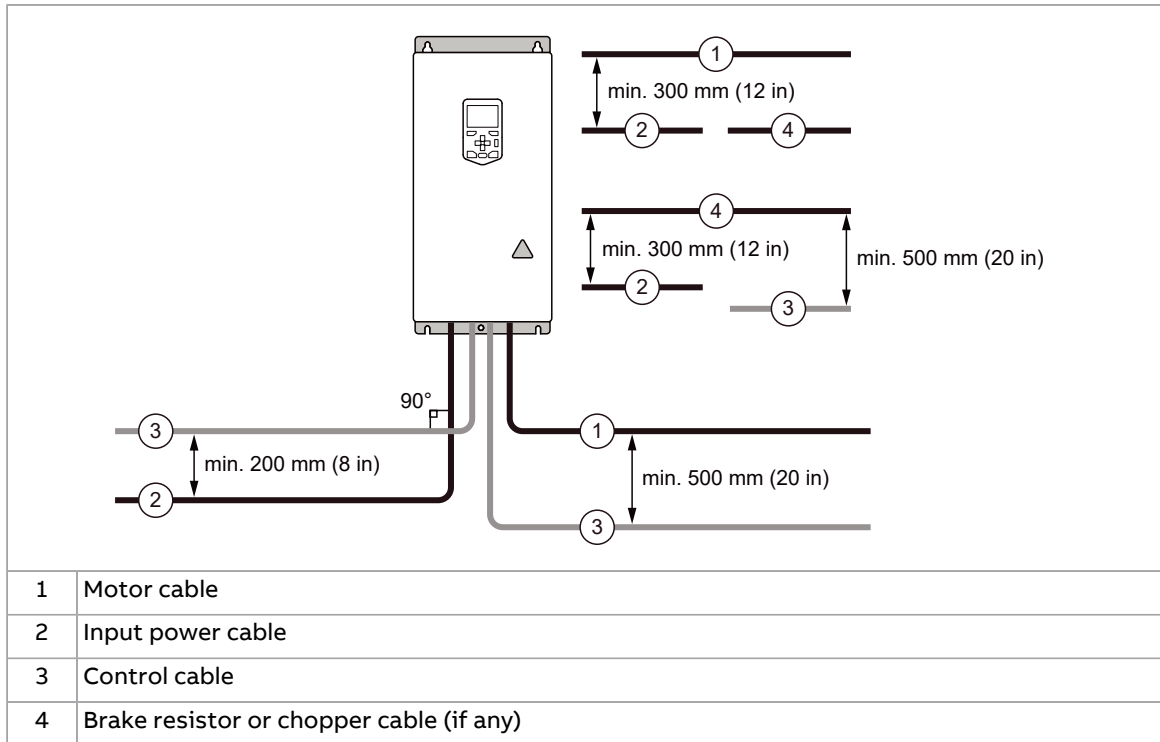

■ **General guidelines – North America**

Make sure that the installation is in accordance with national and local codes. Obey these general guidelines:

- Use separate conduits for the input power, motor, brake resistor (optional), and control cabling.
- Use separate conduit for each motor cabling.

The following figure illustrates the cable routing guidelines with an example drive.

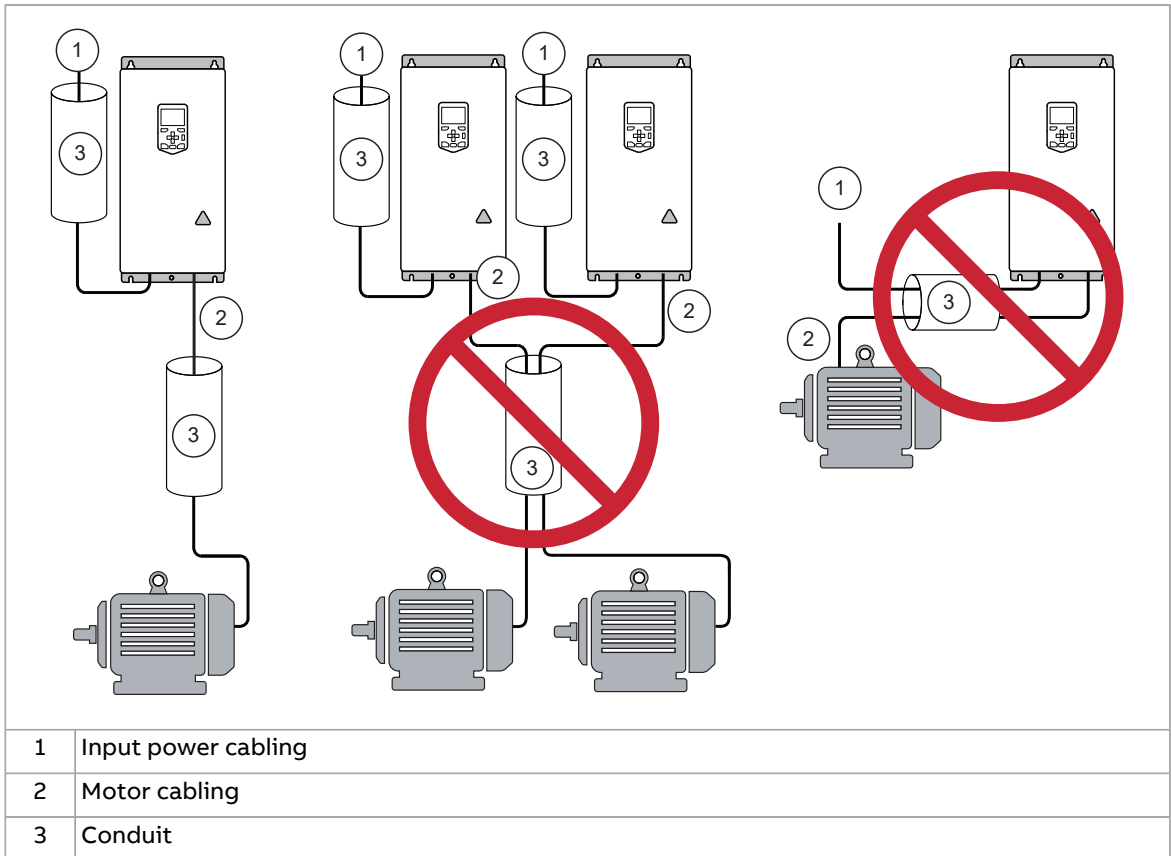

■ **Continuous motor cable shield/conduit and metal enclosure for equipment on the motor cable**

To minimize the emission level when safety switches, contactors, connection boxes or similar equipment are installed on the motor cable between the drive and the motor:

- Install the equipment in a metal enclosure.
- Use either a symmetrical shielded cable, or install the cabling in a metal conduit.
- Make sure that there is a good and continuous galvanic connection in the shield/conduit between drive and motor.
- Connect the shield/conduit to the protective ground terminal of the drive and the motor.

■ **Separate control cable ducts**

Put 24 V DC and 230 V AC (120 V AC) control cables in separate ducts, unless the 24 V DC cable is insulated for 230 V AC (120 V AC) or insulated with an insulation sleeving for 230 V AC (120 V AC).

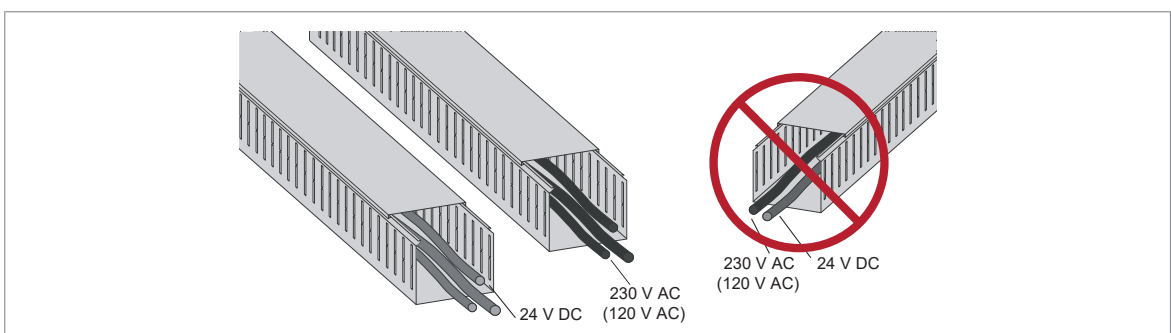

Protecting the drive, input power cable, motor and motor cable in short circuit situations and against thermal overload

■ Protecting the drive and the input power cable in short-circuits

Protect the drive (1) with fuses (a) and the input cable with fuses (b) or a circuit breaker.

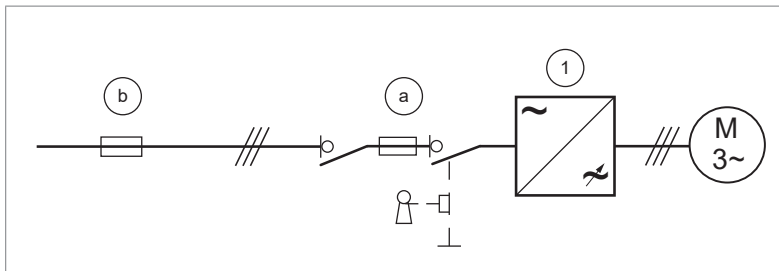

Select the fuses or the circuit breaker according to local regulations for the input cable protection. Select the fuses for the drive according to the instructions given in the technical data. The fuses for the drive protection will restrict drive damage and prevent damage to adjoining equipment in case of a short-circuit inside the drive.

Note: Circuit breakers must not be used without fuses.



▲WARNING Due to the inherent operating principle and construction of circuit breakers, independent of the manufacturer, hot ionized gases can escape from the breaker enclosure in case of a short-circuit. To ensure safe use, pay special attention to the installation and placement of the breakers. Obey the manufacturer's instructions.

■ Tested circuit breakers

You can use the circuit breakers listed in the technical data. Other circuit breakers can be used with the drive if they provide the same electrical characteristics. ABB does not assume any liability whatsoever for the correct function and protection with circuit breakers not listed. Furthermore, if the recommendations given by ABB are not obeyed, the drive can experience problems that the warranty does not cover.

■ Protecting the motor and motor cable in short-circuits

The drive protects the motor cable and motor in a short-circuit situation when:

- the motor cable is sized correctly
- the motor cable type complies with the motor cable selection guidelines by ABB
- the cable length does not exceed the allowed maximum length specified for the drive
- the setting of parameter 99.10 Motor nominal power in the drive is equal with the value given on the motor rating plate.

The electronic power output short-circuit protection circuitry meets the requirements of IEC 60364-4-41:2005 + AMD1:2017.

■ Protecting the motor cables against thermal overload

The drive protects the motor cables against thermal overload when the cables are sized according to the nominal output current of the drive. No additional thermal protection devices are needed.



▲WARNING If the drive is connected to multiple motors, use a separate overload protection for each motor cable and motor. The drive overload protection is tuned for the total motor load. It may not detect an overload in one motor circuit only.

North America: The local code (NEC) requires an overload protection and a short-circuit protection for each motor circuit. Use, for example:

- manual motor protector
- circuit breaker, contactor and overload relay or
- fuses, contactor and overload relay.

■ Protecting the motor against thermal overload

According to regulations, the motor must be protected against thermal overload and the current must be switched off when overload is detected. The drive includes a motor thermal protection function that protects the motor and switches off the current when necessary. Depending on a drive parameter value, the function either monitors a calculated temperature value (based on a motor thermal model) or an actual temperature indication given by motor temperature sensors.

The motor thermal protection model supports thermal memory retention and speed sensitivity. The user can tune the thermal model further by feeding in additional motor and load data.

The most common temperature sensor types are PTC or Pt100.

For more information, see the firmware manual.

■ Protecting the motor against overload without thermal model or temperature sensors

Motor overload protection protects the motor against overload without using motor thermal model or temperature sensors.

Motor overload protection is required and specified by multiple standards including the US National Electric Code (NEC) and the common UL/IEC 61800-5-1 standard in conjunction with UL/IEC 60947-4-1. The standards allow for motor overload protection without external temperature sensors.

The protection feature of the drive allows the user to specify the class of operation in the same manner as the overload relays are specified in standards UL/IEC 60947-4-1 and NEMA ICS 2.

The motor overload protection supports thermal memory retention and speed sensitivity.

For more information, see drive firmware manual.

Protecting the drive against ground faults

The drive is equipped with an internal ground fault protective function to protect the unit against ground faults in the motor and motor cable. This function is not a personnel safety or a fire protection feature. See the firmware manual for more information.

■ Residual current device compatibility

The drive is suitable for use with residual current devices of Type B.

Note: As standard, the drive contains capacitors connected between the main circuit and the frame. These capacitors and long motor cables increase the ground leakage current and may cause nuisance faults in residual current devices.

Implementing a motor temperature sensor connection



▲WARNING IEC 61800-5-1 requires double or reinforced insulation between the live parts and accessible parts when:

- the accessible parts are not conductive, or
- the accessible parts are conductive, but not connected to the protective earth.

Obey this requirement when you plan the connection of the motor temperature sensor to the drive.

You have these implementation alternatives:

1. If there is double or reinforced insulation between the sensor and the live parts of the motor: You can connect the sensor directly to the analog/digital input(s) of the drive. See the control cable connection instructions. Make sure that the voltage is not more than the maximum allowed voltage over the sensor.
 2. If there is basic insulation between the sensor and the live parts of the motor, or if the insulation type is not known: You can connect the sensor to the drive via an option module. The sensor and the module must form a double or reinforced insulation between the motor live parts and the drive control unit. Refer to [Connecting a motor temperature sensor to the drive through an option module \(page 93\)](#). Make sure that the voltage does not exceed the maximum allowed voltage over the sensor.
 3. If there is basic insulation between the sensor and the live parts of the motor, or if the insulation type is not known: You can connect a sensor to a digital input of the drive via an external relay. The sensor and the relay must form a double or reinforced insulation between the motor's live parts and the digital input of the drive. Make sure that the voltage does not exceed the maximum allowed voltage over the sensor.
-

■ Connecting a motor temperature sensor to the drive through an option module

This table shows:

- option module types that you can use for the motor temperature sensor connection
- insulation or isolation level that each option module forms between its temperature sensor connector and other connectors
- temperature sensor types that you can connect to each option module
- temperature sensor insulation requirement in order to form, together with the insulation of the option module, a reinforced insulation between the motor live parts and the drive control unit.

Option module		Temperature sensor type			Temperature sensor insulation requirement
Type	Insulation/Isolation	PTC	KTY	Pt100, Pt1000	
FIO-11	Galvanic isolation between sensor connector and drive control unit connector. No isolation between sensor connector and other I/O connectors.	x	x	x	Reinforced insulation
FEN-01	Galvanic isolation between sensor connector and drive control unit connector. No isolation between sensor connector and TTL encoder emulation output.	x	-	-	Reinforced insulation
FEN-11	Galvanic isolation between sensor connector and drive control unit connector. No isolation between sensor connector and TTL encoder emulation output.	x	x	-	Reinforced insulation
FEN-21	Galvanic isolation between sensor connector and drive control unit connector. No isolation between sensor connector and TTL encoder emulation output.	x	x	-	Reinforced insulation
FEN-31	Galvanic isolation between sensor connector and drive control unit connector. No isolation between sensor connector and other connectors.	x	x	-	Reinforced insulation
FAIO-01	Basic insulation between sensor connector and drive control unit connector. No insulation between sensor connector and other I/O connectors.	x	x	x	Reinforced or basic insulation. With basic insulation, the other I/O connectors of the option module must be kept disconnected.
FPTC-01/02 ¹⁾	Reinforced insulation between sensor connector and other connectors (including drive control unit connector).	x	-	-	No special requirement

¹⁾ Suitable for use in safety functions (SIL2 / PL c classified).

Implementing the emergency stop function

For safety reasons, install the emergency stop devices at each operator control station and at other operating stations where the emergency stop may be needed. Implement the emergency stop according to relevant standards.

Note: You can use the Safe torque off function of the drive to implement the Emergency stop function.

Implementing the Safe torque off function

See [The Safe torque off function \(page 233\)](#).

Implementing the functions provided by the FSO safety functions module

You can order the drive with an FSO-12 safety functions module or FSO-21 safety functions module. An FSO module enables the implementation of functions such as Safe brake control (SBC), Safe stop 1 (SS1), Safe stop emergency (SSE), Safely limited speed (SLS) and Safe maximum speed (SMS).

The settings of the FSO module have default values when delivered from the factory. The wiring of the external safety circuit and configuration of the FSO module are the responsibility of the user.

The FSO module reserves the standard Safe torque off (STO) connection of the drive (or inverter) control unit. STO can still be utilized by other safety circuits through the FSO module.

See the appropriate manual for more information.

Name	Code
FSO-12 safety functions module user's manual	3AXD50000015612
FSO-21 safety functions module user's manual	3AXD50000015614

Implementing the functions provided by the FSPS-21 PROFIsafe safety functions module

You can order the drive with an FSPS-21 PROFIsafe safety functions module, which provides PROFINET and PROFIsafe connection to the drive and has two safety functions integrated into it: Safe torque off (STO) and Safe stop 1, time monitored (SS1-t). With the module, it is possible to control the drive via PROFINET and safely stop the drive via PROFIsafe.

The Safe torque off function can be controlled with PROFIsafe. When using FSPS-21 PROFIsafe safety functions module, other safety functions are not available. Use of PROFIsafe and PROFINET is also possible by using FPNO-21 and FSO option modules.

The settings of the module have default values when delivered from the factory. The wiring and configuration of the FSPS-21 module are the responsibility of the user.

For more information, see [FSPS-21 PROFIsafe safety functions module user's manual \(3AXD50000158638 \[English\]\)](#).

Implementing the functions provided by the FSCS-21 CIP Safety™ functions module

You can order the drive with FSCS-21 CIP Safety™ functions module . The module has two safety functions integrated into it: Safe torque off (STO) and Safe stop 1, time monitored (SS1-t). With the module, you can connect a drive to an Ethernet network and a safety PLC. The module supports the CIP Safety™ communication technology through the EtherNet/IP communication protocol. The intended use of the FSCS module is to safely stop the drive when necessary. A safety PLC can activate the safety functions of the module.

The settings of the FSCS module have default values when delivered from the factory. The wiring and configuration of the FSCS module are the responsibility of the user. The FSCS module reserves the standard Safe torque off (STO) connection of the drive (or inverter) control unit.

For more information, refer to [FSCS-21 CIP Safety™ functions module user's manual \(3AXD50001065478 \[English\]\)](#).

Using power factor compensation capacitors with the drive

Power factor compensation is not needed with AC drives. However, if a drive is to be connected in a system with compensation capacitors installed, note the following restrictions.

NOTICE Do not connect power factor compensation capacitors or harmonic filters to the motor cables (between the drive and the motor). They are not designed for use with AC drives and can cause permanent damage to the drive or themselves.

If there are power factor compensation capacitors in parallel with the input of the drive:

1. Do not connect a high-power capacitor to the power line while the drive is connected. The connection will cause voltage transients that can trip or cause damage to the drive.
2. If capacitor load is increased/decreased step by step when the AC drive is connected to the power line, make sure that the connection steps are low enough not to cause voltage transients that would trip the drive.
3. Make sure that the power factor compensation unit is suitable for use in systems with AC drives, ie, harmonic generating loads. In such systems, the compensation unit should typically be equipped with a blocking reactor or harmonic filter.

Using a safety switch between the drive and the motor

ABB recommends to install a safety switch between the permanent magnet motor and the drive output. The switch is needed to isolate the motor from the drive during maintenance work on the drive.

Implementing an ATEX-certified motor thermal protection

With option +Q971, the drive provides ATEX-certified safe motor disconnection without contactor using the drive Safe torque off function. To implement the thermal protection of a motor in explosive atmosphere (Ex motor), you must also:

- use an ATEX-certified Ex motor
- order an ATEX-certified thermistor protection module for the drive (option +L537), or acquire and install an ATEX-compliant protection relay
- do the necessary connections.

For more information, see:

User's manual	Manual code (English)
ATEX-certified Safe disconnection function, Ex II (2) GD for ACS880 drives (+Q971) application guide	3AUA0000132231
FPTC-02 ATEX-certified thermistor protection module, Ex II (2) GD (option +L537+Q971) for ACS880 drives user's manual	3AXD50000027782
FPTC-02 ATEX-certified thermistor protection module, instructions for pairing the module with a drive with the ATEX-certified disconnection function (option +Q971)	3AXD50001096700

Implementing the power loss ride-through function

If the incoming supply voltage is cut off, the drive will continue to operate by utilizing the kinetic energy of the rotating motor. The drive will be fully operational as long as the motor rotates and generates energy to the drive.

If you equip the drive with a main contactor or breaker, make sure that it restores the drive input power after a short break. The contactor must either re-connect after the break automatically, or remain closed over the break. Depending on the contactor control circuit design, this can require an additional hold circuit, uninterruptible auxiliary power supply or auxiliary power supply buffering.

Note: If the power loss lasts so long that the drive trips on undervoltage, a fault reset and a fresh start command is required to continue operation.

Implement the power-loss ride-through function as follows:

1. Enable the power-loss ride-through function of the drive (parameter 30.31).
2. If the installation is equipped with a main contactor, prevent its tripping at the input power break. For example, use a time delay relay (hold) in the contactor control circuit.
3. Enable the automatic restart of the motor after a short power supply break:
 - Set the start mode to automatic (parameter 21.01 or 21.19, depending on the motor control mode being used).
 - Define the automatic restart time (parameter 21.18).



WARNING Make sure that a flying restart of the motor will not cause any danger. If you are in doubt, do not implement the power loss ride-through function.

Controlling a contactor between drive and motor

The control of the output contactor depends on how you use the drive, that is, which motor control mode and which motor stop mode you select.

If you have the DTC motor control mode and the motor ramp stop mode selected, use this operation sequence to open the contactor:

1. Give a stop command to the drive.
2. Wait until the drive decelerates the motor to zero speed.
3. Open the contactor.

If you have the DTC motor control mode and the motor coast stop, or scalar control mode selected, open the contactor as follows:

1. Give a stop command to the drive.
2. Open the contactor.



WARNING When the DTC motor control mode is in use, never open the output contactor while the drive controls the motor. The DTC motor control operates extremely fast, much faster than it takes for the contactor to open its contacts. When the contactor starts opening while the drive controls the motor, the DTC control will try to maintain the load current by immediately increasing the drive output voltage to the maximum. This will damage, or even burn, the contactor completely.

Implementing a bypass connection

If bypassing is required, use mechanically or electrically interlocked contactors between the motor and the drive and between the motor and the power line. Make sure with interlocking that the contactors cannot be closed simultaneously. The installation must be clearly marked as defined in IEC/EN/UL 61800-5-1, subclause 6.5.3, for example, "THIS MACHINE STARTS AUTOMATICALLY".

NOTICE Do not connect the drive output to the electrical power network. The connection can cause damage to the drive.

■ **Example bypass connection**

An example bypass connection is shown below.

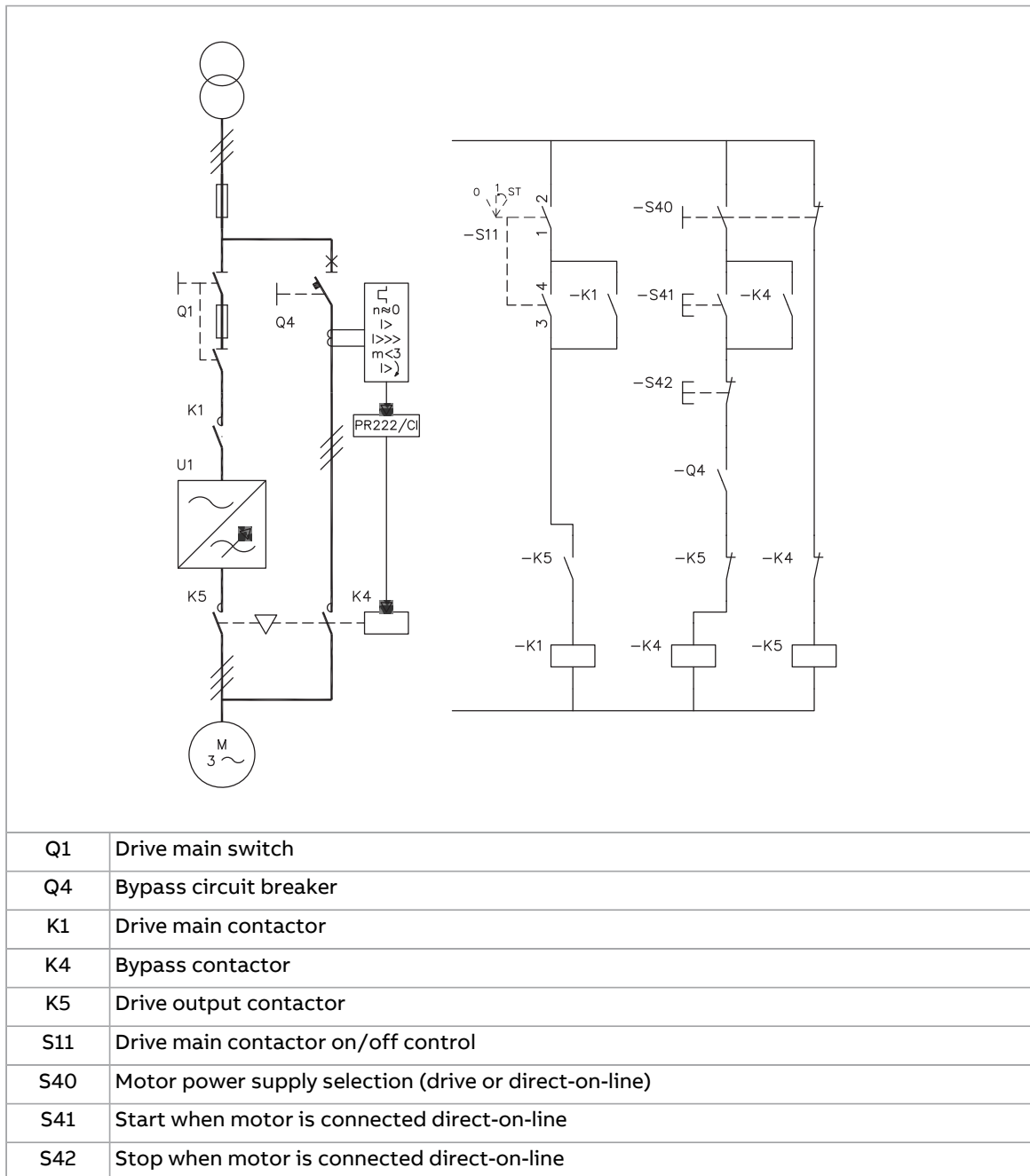

Switching the motor power supply from drive to direct-on-line

1. Stop the drive and the motor with the drive control panel stop key (drive in the local control mode) or the external stop signal (drive in the remote control mode).
2. Open the main contactor of the drive with S11.
3. Switch the motor power supply from the drive to direct-on-line with S40.
4. Wait for 10 seconds to allow the motor magnetization to dissipate.
5. Start the motor with S41.

Switching the motor power supply from direct-on-line to drive

1. Stop the motor with S42.
2. Switch the motor power supply from direct-on-line to the drive with S40.
3. Close the main contactor of the drive with switch S11 (-> turn to position ST for two seconds and leave to position 1).
4. Start the drive and the motor with the drive control panel start key (drive in the local control mode) or the external start signal (drive in remote control mode).

Protecting the contacts of relay outputs

Inductive loads (relays, contactors, motors) cause voltage transients when switched off.

The relay contacts on the drive control unit are protected with varistors (250 V) against overvoltage peaks. In spite of this, it is highly recommended that inductive loads are equipped with noise attenuating circuits (varistors, RC filters [AC] or diodes [DC]) to minimize the EMC emission at switch-off. If not suppressed, the disturbances may connect capacitively or inductively to other conductors in the control cable and form a risk of malfunction in other parts of the system.

Install the protective component as close to the inductive load as possible. Do not install protective components at the relay outputs.

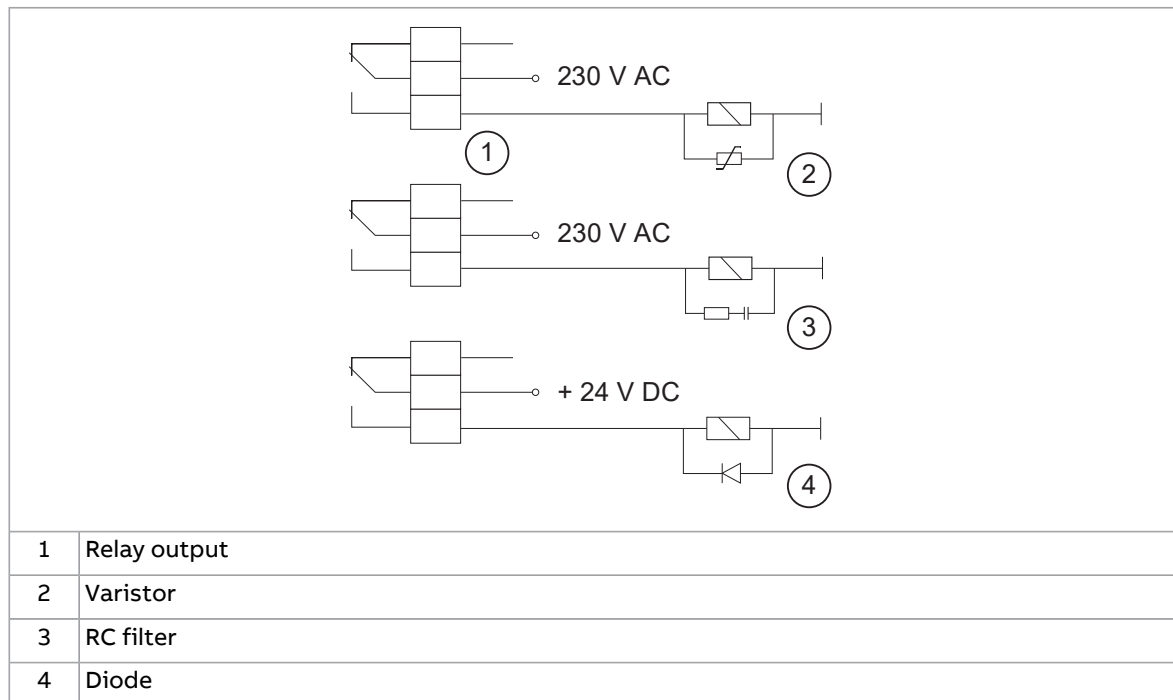

7

Electrical installation

Contents of this chapter

This chapter contains instructions for electrical installation of the drive module. The chapter refers to installation example chapters which contain instructions that depend on the selected drive configuration.

Safety



▲WARNING Obey the safety instructions of the drive. If you ignore them, injury or death, or damage to the equipment can occur. If you are not a qualified electrical professional, do not do electrical installation, commissioning or maintenance work.

■ Handling fiber optic cables

NOTICE Obey these instructions. If you ignore them, damage to the equipment can occur.

- Handle the fiber optic cables with care.
 - When you disconnect the fiber optic cables, always hold the connector, not the cable.
 - Do not touch the ends of the fibers. They are sensitive to dirt.
 - Do not bend the fiber optic cables too tightly. The minimum allowed bend radius is 35 mm (1.4 in).
-



Grounding the motor cable shield at the motor end

For minimum radio-frequency interference, ground the cable shield 360° at the cable entry of the motor terminal box.

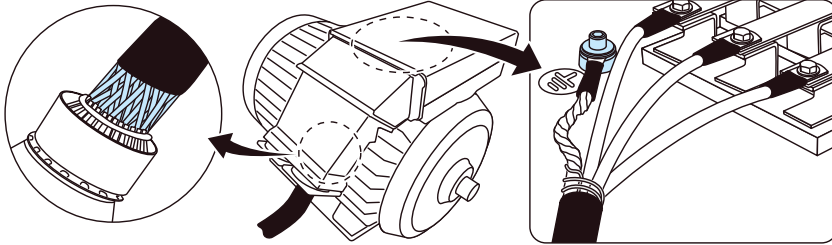

Measuring the insulation

■ Measuring the insulation resistance of the drive

NOTICE Do not do voltage withstand or insulation resistance tests on the drive. The tests can cause damage to the drive. Every drive is tested for insulation between the main circuit and the chassis at the factory. Also, there are voltage-limiting circuits inside the drive which cut down the testing voltage automatically.

■ Measuring the insulation resistance of the input power cable

Before you connect the input power cable to the drive, measure its insulation resistance according to local regulations.

■ Measuring the insulation resistance of the motor and motor cable



▲WARNING Obey the safety instructions of the drive. If you ignore them, injury or death, or damage to the equipment can occur. If you are not a qualified electrical professional, do not do installation, commissioning, or maintenance work.

1. Do the steps in section [Electrical safety precautions \(page 18\)](#) before you start the work.
2. Make sure that the motor cable is disconnected from the drive output terminals.
3. Measure the insulation resistance between each phase conductor and the protective earth conductor. Use a measuring voltage of 1000 V DC. The insulation resistance of an ABB motor must be more than 100 Mohm (reference value at 25 °C [77 °F]). For the insulation resistance of other motors, refer to the manufacturer's instructions.

Note: Moisture inside the motor reduces the insulation resistance. If you think that there is moisture in the motor, dry the motor and do the measurement again.

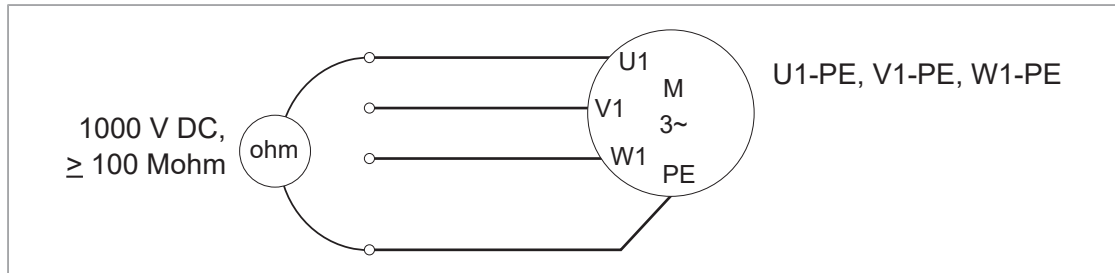

■ Measuring the insulation resistance of the brake resistor circuit



▲WARNING Obey the safety instructions of the drive. If you ignore them, injury or death, or damage to the equipment can occur. If you are not a qualified electrical professional, do not do electrical installation, commissioning or maintenance work.

1. Stop the drive and do the steps in section [Electrical safety precautions \(page 18\)](#) before you start the work.
2. Make sure that the resistor cable is connected to the resistor and disconnected from the drive output terminals.
3. At the drive end, connect the R+ and R- conductors of the resistor cable together. Measure the insulation resistance between the conductors and the PE conductor with a measuring voltage of 1000 V DC. The insulation resistance must be more than 1 Mohm.

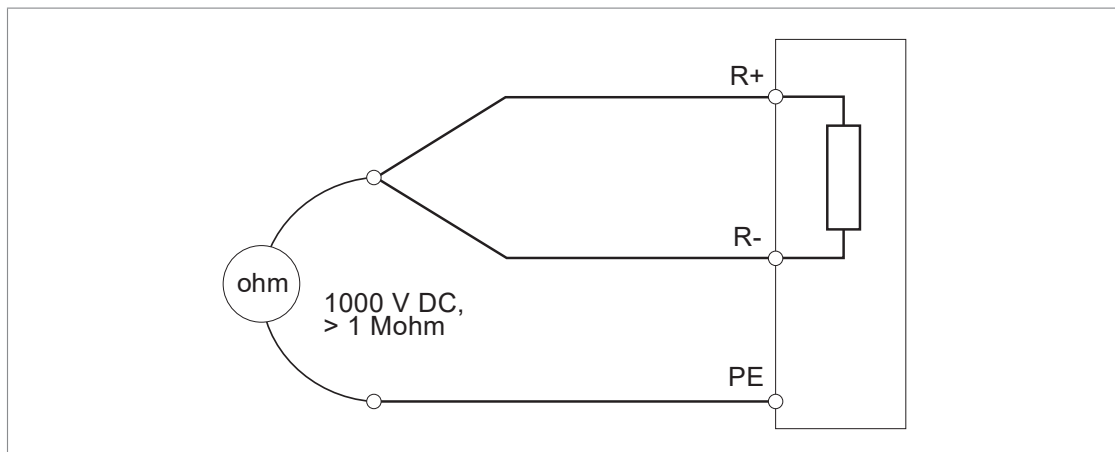

Grounding system compatibility check

The standard drive with no EMC filter and the ground-to-phase varistor connected can be installed to a symmetrically grounded TN-S system. If you install the drive to another system, you may need to disconnect the EMC filter and ground-to-phase varistor. Refer to [ACS880 frames R1 to R11 EMC filter and ground-to-phase varistor disconnecting instructions \(3AUA0000125152 \[English\]\)](#)



▲CAUTION Do not install the drive with EMC filter option +E200 to a system that the filter is not suitable for. This can cause danger, or damage the drive.

NOTICE Do not install the drive with the ground-to-phase varistor connected to a system that the varistor is not suitable for. It can cause damage to the varistor circuit.

■ **Corner-grounded and midpoint-grounded 525...690 V delta systems**

NOTICE Do not install the drive on a 525...690 V corner-grounded or midpoint-grounded delta system. Disconnecting the EMC filter and ground-to-phase varistor does not prevent damage to the drive.

Installing the EMC filter (option +E202)

See [ARFI-10 EMC filter installation guide \(3AFE68317941 \[English\]\)](#).



Connecting the power cables

■ Power cable connection diagram

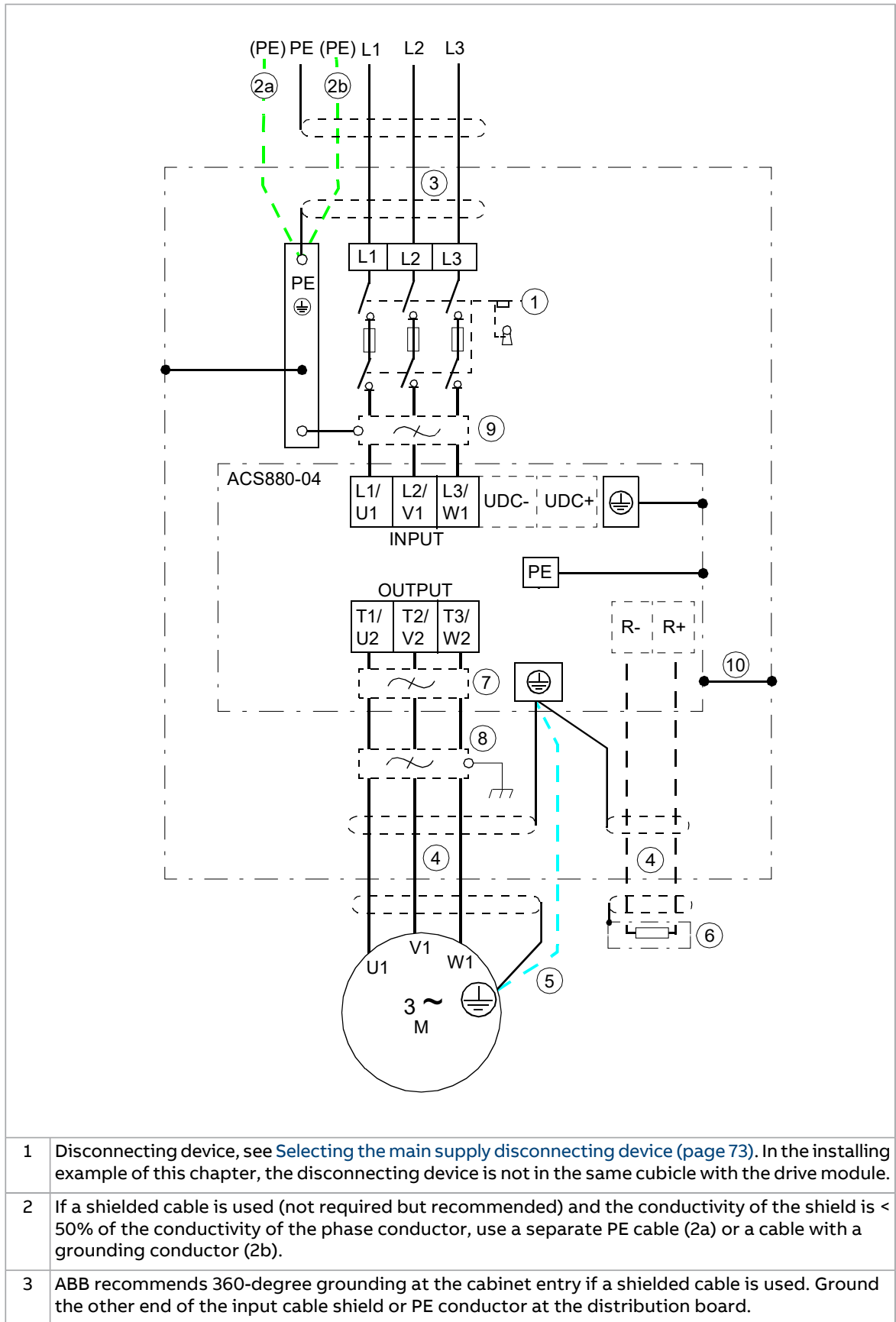

4	ABB recommends 360-degree grounding at the cabinet entry.
5	Use a separate grounding cable if the conductivity of the cable shield is < 50% of the conductivity of the phase conductor and there is no symmetrically constructed grounding conductor in the cable, see Power cable types (page 82)
6	External brake resistor (optional, see Resistor braking (page 251))
7	Common mode filter (optional, see Requirements tables (page 75))
8	du/dt filter (optional, see du/dt filters (page 259))
9	EMC filter (option +E202, see section Installing the EMC filter (option +E202) (page 104))
10	The drive module frame must be connected to the cabinet frame, see Alternatives for grounding the drive module (page 69)

If there is a symmetrically constructed grounding conductor in the motor cable in addition to the conductive shield, connect the grounding conductor to the grounding terminal at the drive and motor ends. Do not use an asymmetrically constructed motor cable. Connecting its fourth conductor at the motor end increases bearing currents and causes extra wear.

■ Preparing the cable ends and making 360° grounding at the cable entry



⚠ WARNING Obey the safety instructions of the drive. If you ignore them, injury or death, or damage to the equipment can occur. If you are not a qualified electrical professional, do not do electrical installation, commissioning or maintenance work.

1. Do the steps in section [Electrical safety precautions \(page 18\)](#) before you start the work.
2. Peel off 3...5 cm (1 1/4 ... 2 in) of the outer insulation of the cables at the cable entries with the conductive sleeves for the 360° high-frequency grounding.

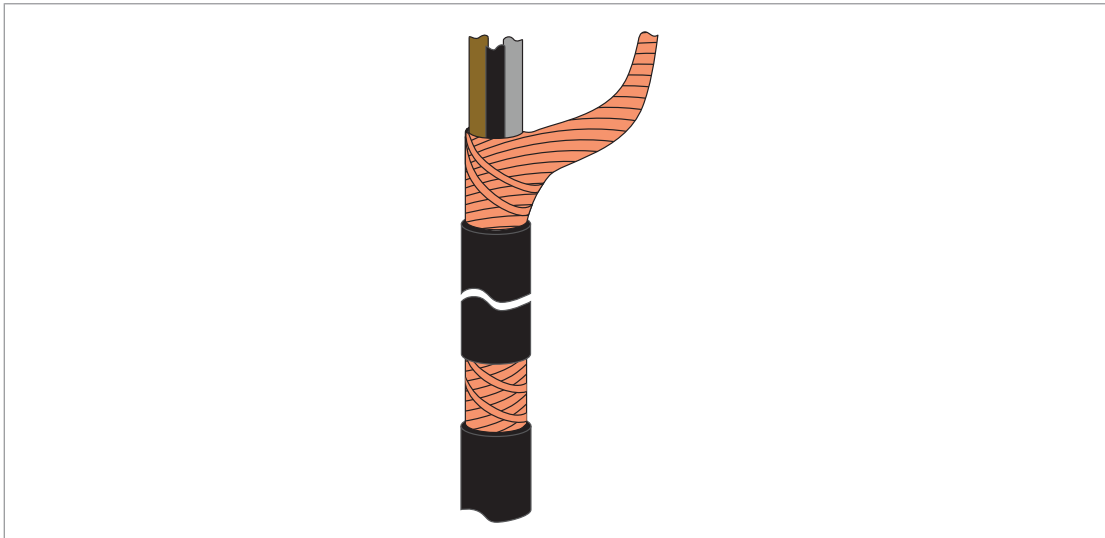

3. Prepare the ends of the cables.

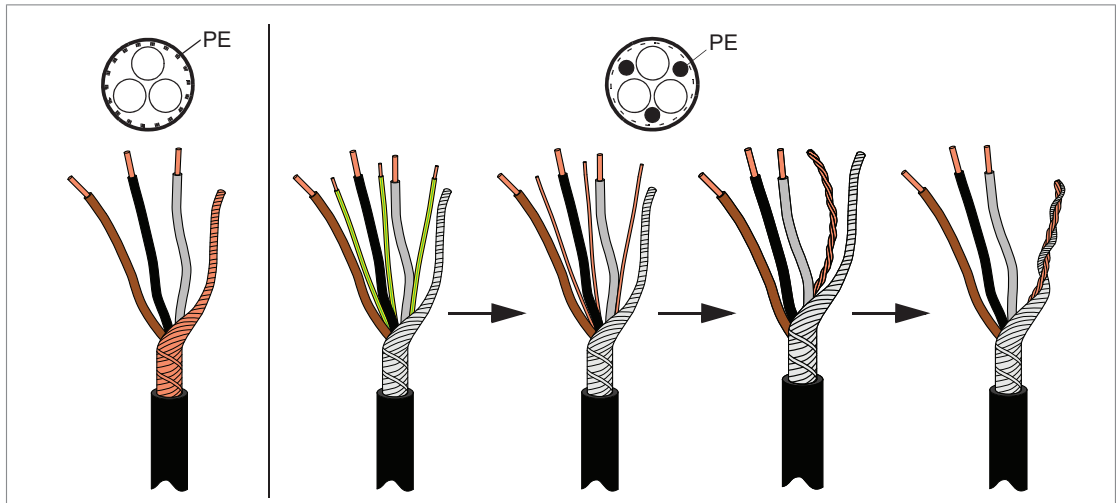

4. Put the cables through the entry plate. If the entry holes have rubber grommets, use one grommet for each cable. Cut adequate hole into the grommet and put the cable through the grommet inside the cabinet.
5. Attach the conductive sleeves to the cable shields with cable ties. Tie up the unused conductive sleeves with cable ties. An example of bottom entry is shown below. For top entry, put the grommet upwards.

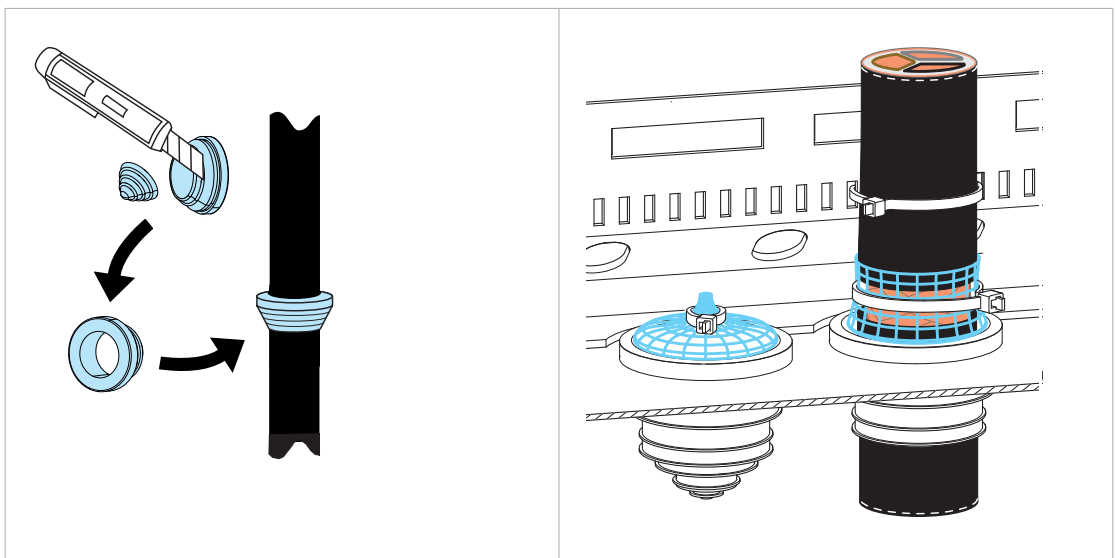

■ Power cable connection procedure



▲WARNING Obey the safety instructions of the drive. If you ignore them, injury or death, or damage to the equipment can occur. If you are not a qualified electrical professional, do not do electrical installation, commissioning or maintenance work.

1. Do the steps in section [Electrical safety precautions \(page 18\)](#) before you start the work.
2. Connect the cable shields of the motor cables and any separate ground conductors or cables to the ground terminal of the drive module or to the cabinet ground bar.

3. Connect the phase conductors of the motor cables to terminals T1/U2, T2/V2 and T3/W2 of the drive module. For the tightening torques, see the technical data.
4. Drive modules with option +D150: Connect the brake resistor conductors to the R+ and R- terminals. For the tightening torques, see the technical data.
5. Connect the cable shields of the input cables and any separate ground conductors or cables to the drive module ground terminal or to the cabinet PE busbar.
6. Connect the phase conductors of the input cables to terminals L1/U1, L2/V1 and L3/W1 of the drive module. For the tightening torques, see the technical data.

■ DC connection

The UDC+ and UDC– terminals are intended for common DC configurations of a number of drives, allowing regenerative energy from one drive to be utilized by the other drives in the motoring mode. See [ACS880-01 drives and ACS880-04 drive modules common DC systems application guide \(3AUA0000127818 \[English\]\)](#).

Removing the control panel holder from the external control unit

1. Disconnect the control panel cable from connector X13 on the control unit.
2. Loosen the mounting screws of the control panel holder and take the holder off.

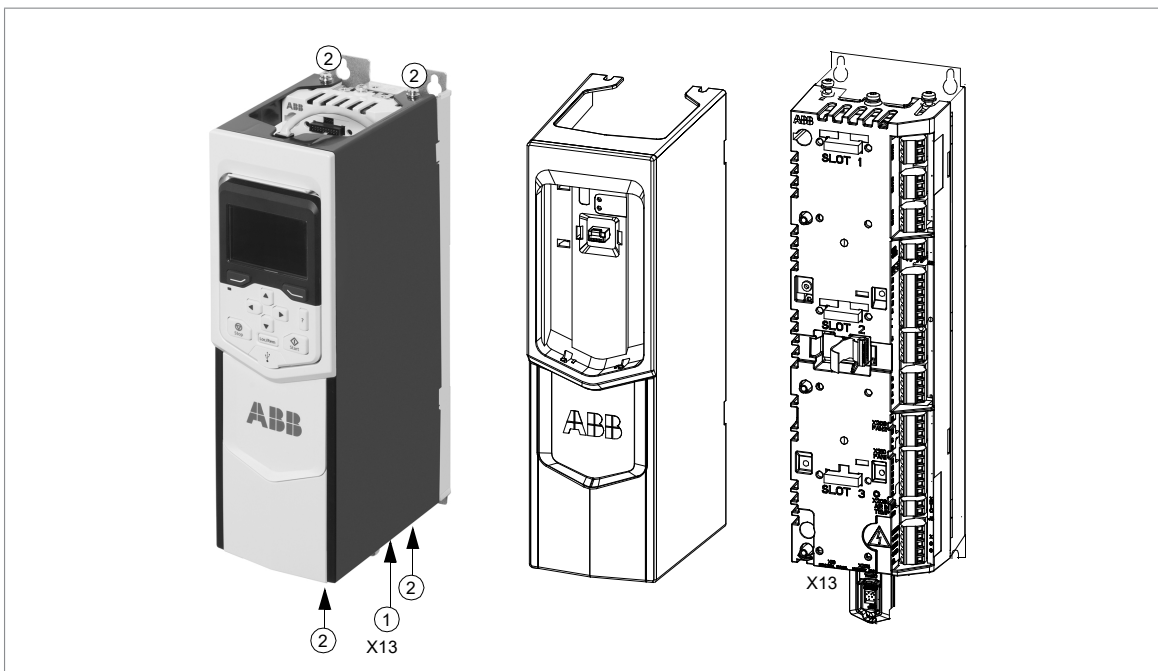

Attaching the control cable clamp plate

Attach the control cable clamp plate either to the top or base of the control unit with four screws as shown below.

Note: If you install the FSO-xx safety functions module above the control unit, attach the control cable clamp plate on the base of the control unit.

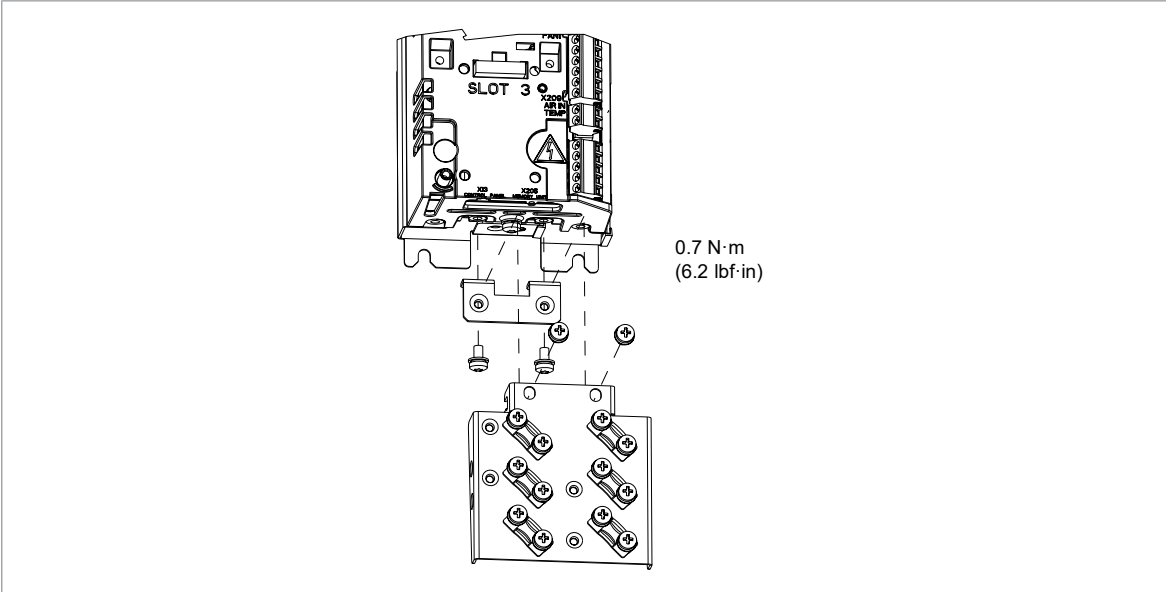

Connecting the external control unit to the drive module

- **Control unit connection cables**

The cables that are delivered with the drive module for connecting the drive module and control panel to the control unit are shown below.

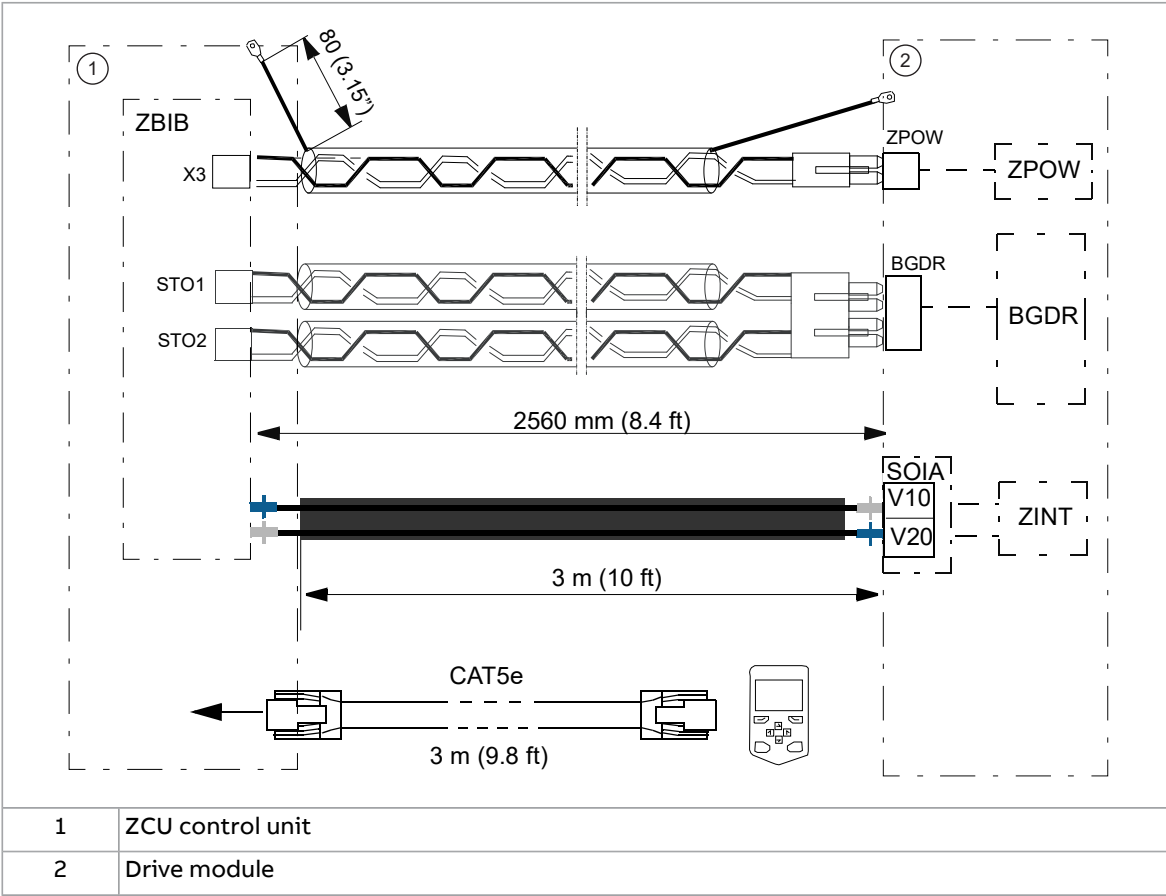

NOTICE Obey these instructions. If you ignore them, equipment malfunction and damage to the fiber-optic cables can occur.

- Handle the fiber-optic cables with care.
- When you disconnect the cables, always hold the connector, not the cable itself.
- Do not touch the ends of the optical fibers with bare hands, because the ends are very sensitive to dirt.
- Do not bend the fiber-optic cables too tightly. The minimum permitted bend radius is 35 mm (1.4 in).

■ Routing the control unit cables into the drive module

Route the control unit connection cables to the drive module through the slot in the middle front cover at the front or left side. First, remove the plate which covers the slot. Then, install the rubber grommet (item 2) from the accessories box.

■ Connections to the drive module

1. Connect power supply cable of the control unit to the ZPOW connector and the ground wire of the cable to the ground terminal.
2. Connect the BGDR cable to the BGDR connector.
3. Connect the fiber optic cables to the V20 and V10 connectors.

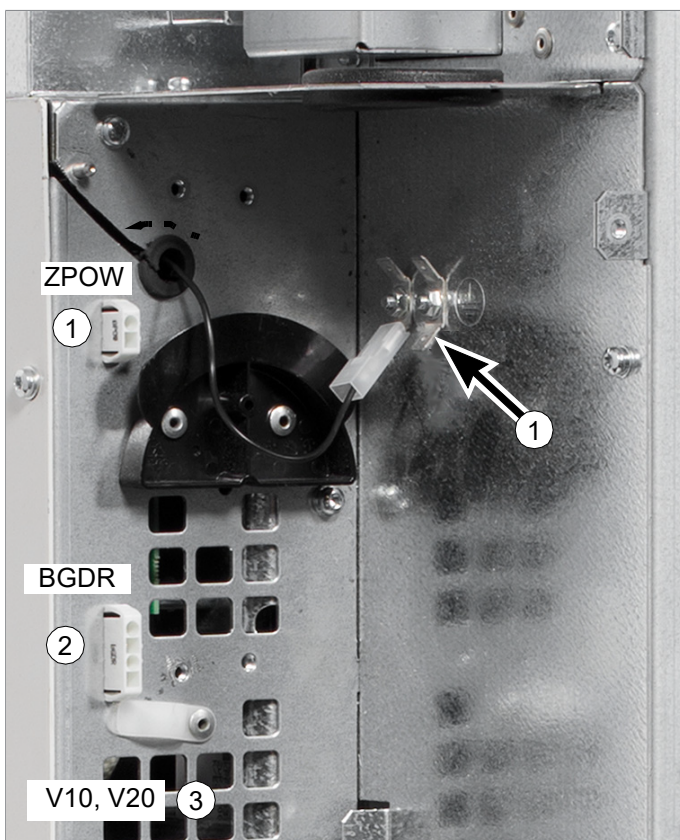

■ Connections to the control unit

Connect the fiber optic, power supply and BGDR cables to the control unit as follows:

1. Thread the cables inside the back frame of the control unit.
2. Connect the cables to the ZBIB board terminals.

ZPOW	ZBIB
X3:1	X3:1
X3:2	X3:2
X3:3 (not used)	X3:3 (not used)
BGDR	ZBIB
X7 (STO1)	X7 (STO1)
X8 (STO2)	X8 (STO2)

SOIA	ZBIB
V10	V1
V20	V2

3. Connect the ZPOW cable grounding wire to the grounding terminal at the back top or bottom of the control unit.

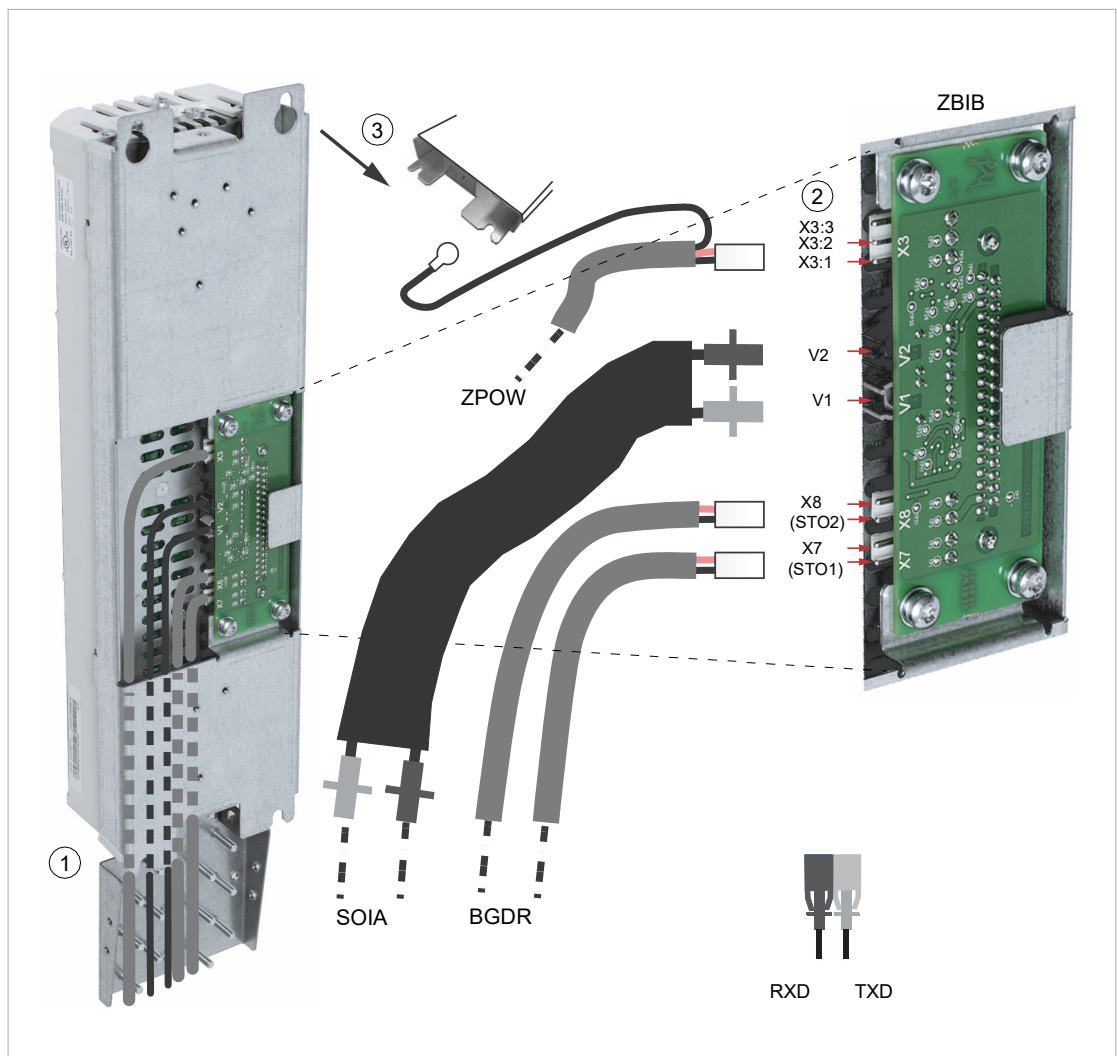

RXD = receiver TXD = transmitter

Connecting the control cables to the terminals of the external control unit

1. Route the cables to the control unit as shown below.

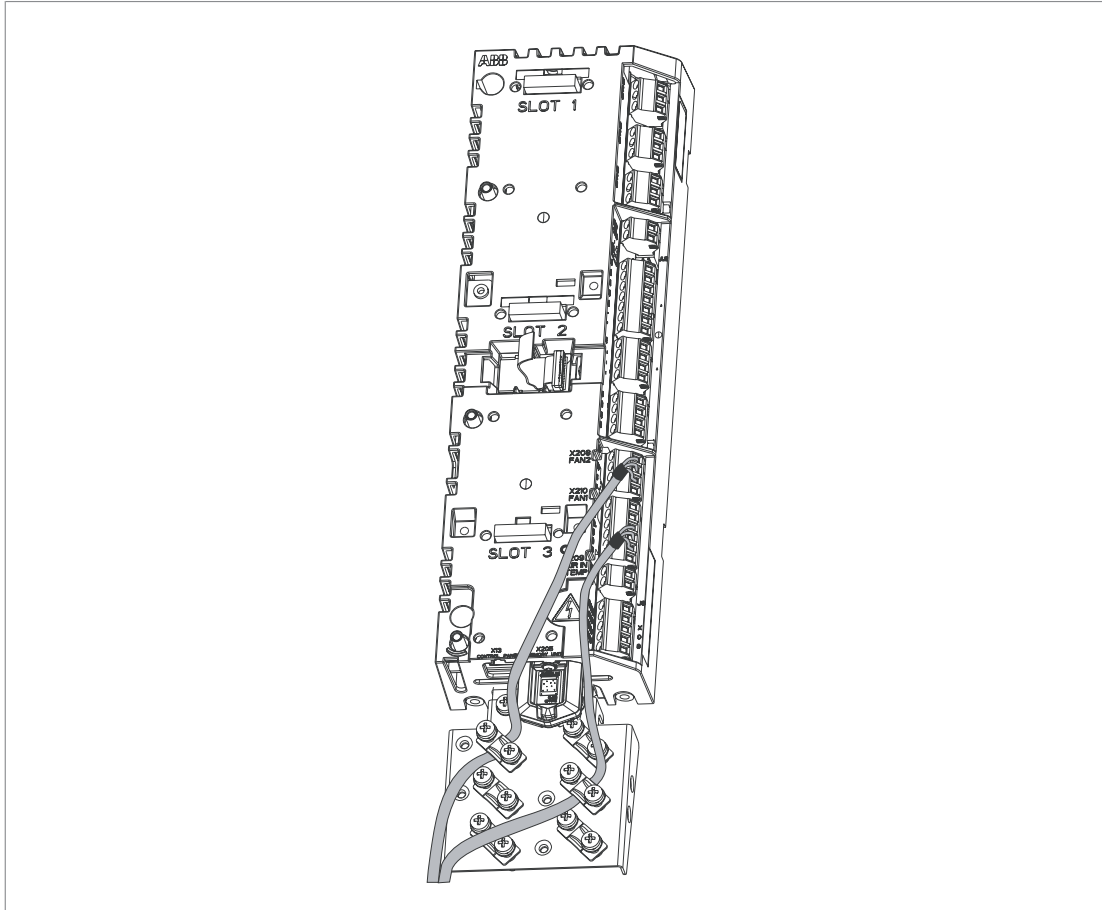

2. Ground the shields of the control cables at the clamp plate. Use torque 1.5 N·m (13 lbf·in). The shields should be continuous as close to the terminals of the control unit as possible. Only remove the outer jacket of the cable at the cable clamp so that the clamp presses on the bare shield. The shield (especially in case of multiple shields) can also be terminated with a lug and fastened with a screw at the clamp plate. Leave the other end of the shield unconnected or ground it indirectly via a few nanofarads high-frequency capacitor eg, 3.3 nF / 630 V. The shield can also be grounded directly at both ends if they are in the same ground line with no significant voltage drop between the end points. Tighten the screws to secure the connection.
3. Connect the conductors to the appropriate detachable terminals of the control unit. See the [Default control connection diagram of the drive control unit \(ZCU\) \(page 123\)](#). Use shrink tubing or insulating tape to contain any strain strands.

Note: Keep any signal wire pairs twisted as close to the terminals as possible. Twisting the wire with its return wire reduces disturbances caused by inductive coupling. Keep the shields continuous as close to the terminals of the control unit as possible.

Connecting the control cables to the integrated control unit (option +P905)

1. Ground the outer control cable shields 360 degrees at the cabinet entry plate (recommendation).
2. Remove the middle front cover of the drive module (view of standard drive module configuration below).
3. Attach the clamp plate to the top of the control unit with two screws from front, see [Attaching the control cable clamp plate \(page 108\)](#).
4. Fasten the optional modules if not attached already.
5. Remove the cover plate from the control cable entry plate and put the rubber grommet in its place. Put the control cables through the grommet.

Note: If you route the control cables from top or bottom instead of front or side, you need to make holes for the entries to the clear plastic shrouds.

6. Ground the control cables at the clamp plate as described in Step 2 in section [Connecting the control cables to the terminals of the external control unit \(page 112\)](#).
7. Connect the conductors to the appropriate detachable terminals of the control unit, see [Default control connection diagram of the drive control unit \(ZCU\) \(page 123\)](#). Use shrink tubing or insulating tape to contain any stray strands. Tighten the screws to secure the connection.

Note: Keep any signal wire pairs twisted as close to the terminals as possible. Twisting the wire with its return wire reduces disturbances caused by inductive coupling.

8. Install the middle front cover back.



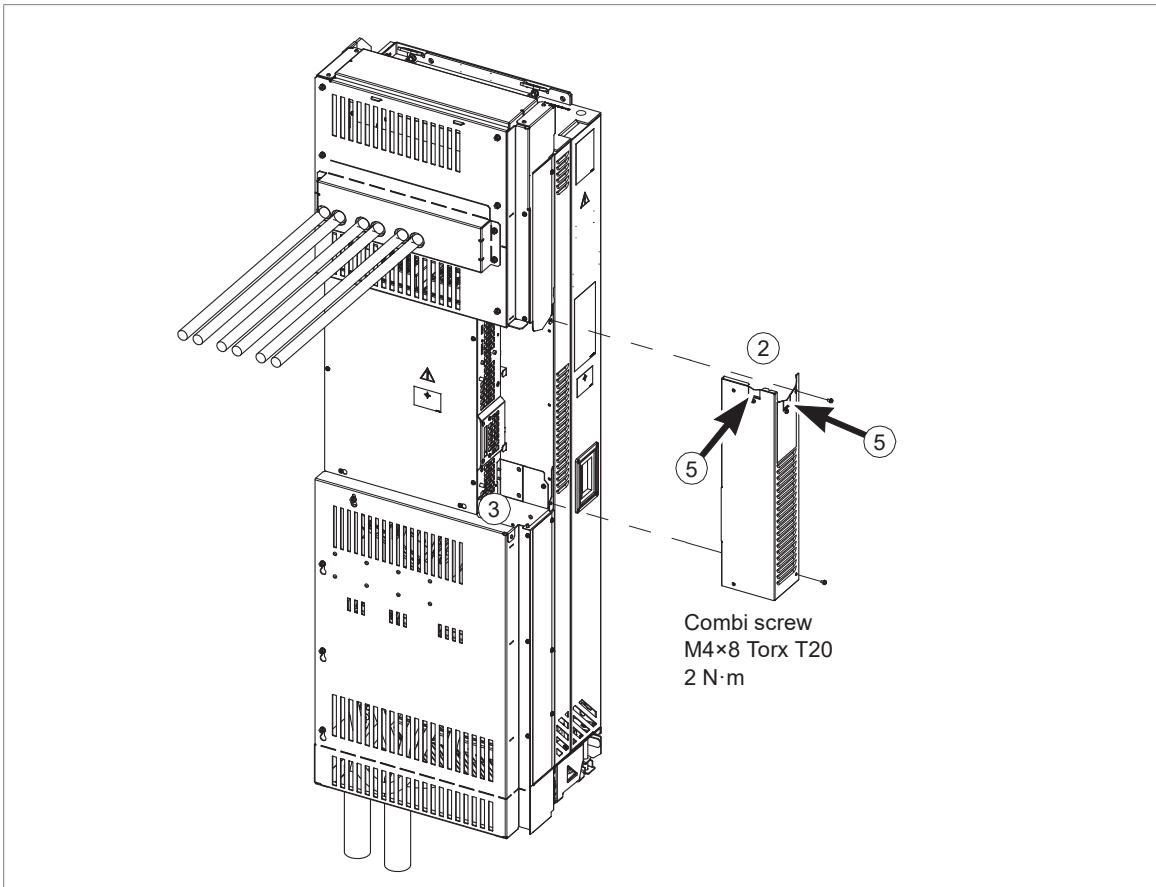

Connecting the control cables to the integrated control unit (options +P905 and +OB051)



1. Remove the middle front cover of the drive module.
2. Attach the clamp plate to the control unit with two screws from front, see [Attaching the control cable clamp plate \(page 108\)](#).
3. Attach the optional modules if not fastened already.
4. Put the control cables inside the drive cabinet.
5. Route the control cables along the control cable duct from bottom or top to the control unit. A view of a drive module with full cabling panels (option +H381) is shown below.
6. Ground the outer control cable shields 360 degrees at the cabinet entry plate (recommendation).
7. Ground the control cables at the clamp plate as described in Step 2 in section [Connecting the control cables to the terminals of the external control unit \(page 112\)](#).
8. Connect the conductors to the appropriate detachable terminals of the control unit, see [Default control connection diagram of the drive control unit \(ZCU\) \(page 123\)](#). Use shrink tubing or insulating tape to contain any stray strands. Tighten the screws to secure the connection.

Note: Keep any signal wire pairs twisted as close to the terminals as possible. Twisting the wire with its return wire reduces disturbances caused by inductive coupling.



Connecting a control panel

Connect the control panel as follows:

1. Connect an Ethernet cable to the RJ-45 connector of the control panel.
2. Connect the other end of the cable to the X13 connector of the control unit.

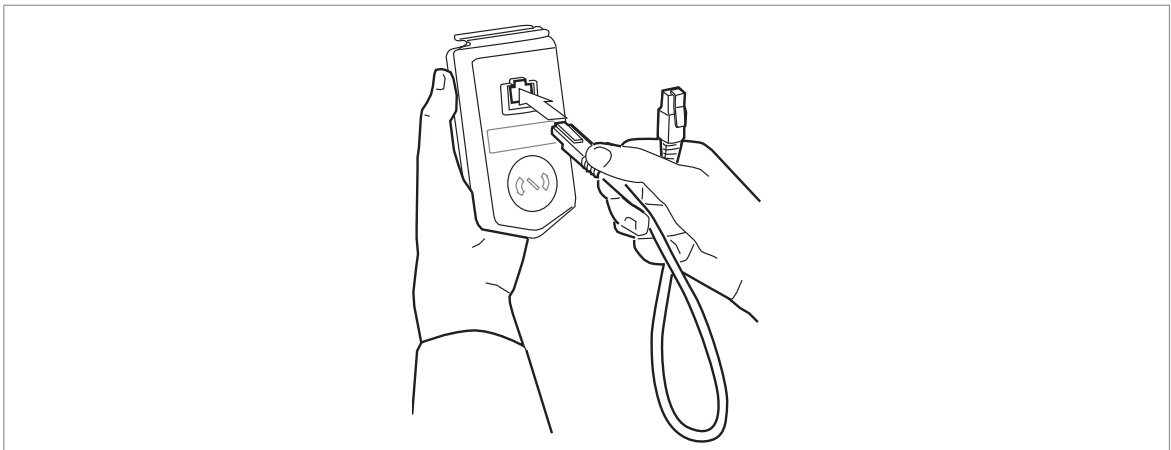

Note: When a PC is connected to the control panel, the control panel keypad is disabled. In this case, the control panel acts as a USB-RS485 adapter.

Panel bus (control of several units from one control panel)

One control panel (or PC) can be used to control several drives (or inverter units, supply units etc.) by constructing a panel bus. This is done by daisy-chaining the panel

connections of the drives. Some drives have the necessary (twin) panel connectors in the control panel holder; those that do not require the installation of an FDPI-02 module (available separately). For further information, see the hardware description and [FDPI-02 diagnostics and panel interface user's manual \(3AUA0000113618 \[English\]\)](#).

The maximum allowed length of the cable chain is 100 m (328 ft).

Do the steps in section [Electrical safety precautions \(page 18\)](#) before you start the work.

1. Connect the panel to one drive using an Ethernet (for example Cat 5e) cable.
 - Use Menu - Settings - Edit texts - Drive to give a descriptive name to the drive
 - Use parameter 49.01* to assign the drive with a unique node ID number
 - Set other parameters in group 49* if necessary
 - Use parameter 49.06* to validate any changes.

*The parameter group is 149 with supply (line-side), brake or DC/DC converter units.

Repeat the above for each drive.

2. With the panel connected to one unit, link the units using Ethernet cables.
3. Switch on the bus termination on the drive that is farthest from the control panel in the chain.
 - With drives that have the panel mounted on the front cover, move the terminating switch into the outer position.
 - With the FDPI-02 module: move termination switch S1 on the FDPI-02 module into the TERMINATED position.

Make sure that bus termination is off on all other drives.

4. On the control panel, switch on the panel bus functionality (Options - Select drive - Panel bus). The drive to be controlled can now be selected from the list under Options - Select drive.

If a PC is connected to the control panel, the drives on the panel bus are automatically displayed in the Drive Composer PC tool.

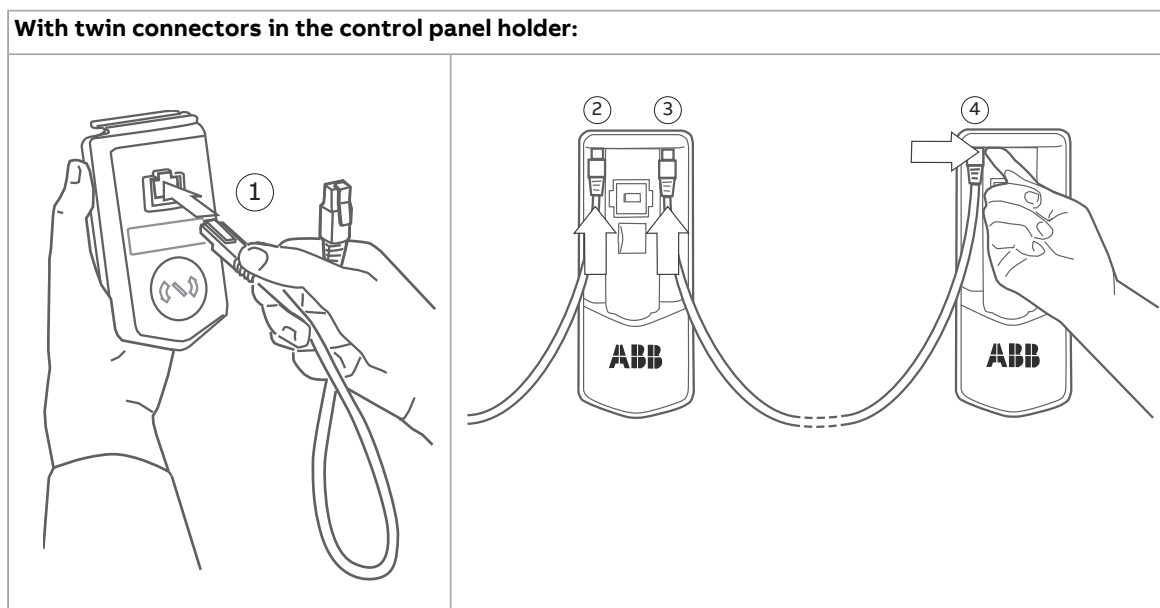

With FDPI-02 modules:

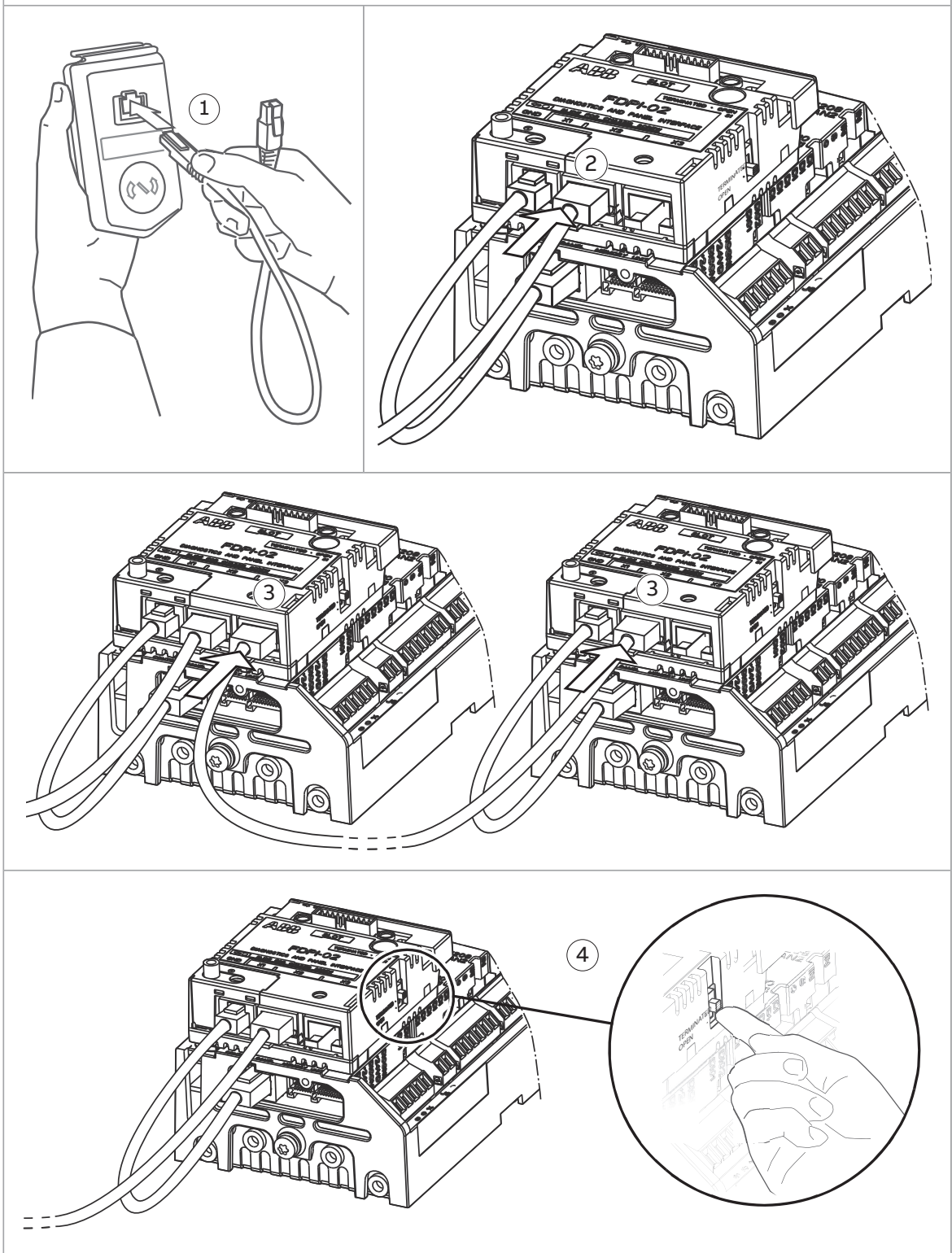

Connecting a PC

NOTICE Do not connect a PC directly to the control panel connector of the control unit. It can cause damage.

To connect a control panel to a PC (with, for example, Drive Composer PC tool):

1. Put the control panel into the panel holder or platform.
2. Remove the USB connector cover on the front of the control panel.
3. Connect an USB cable (Type A to Type Mini-B) between the USB connector on the control panel (3a) and a free USB port on the PC (3b).
4. The panel will display an indication whenever the connection is active.
5. Refer to the documentation of the PC tool for setup instructions.

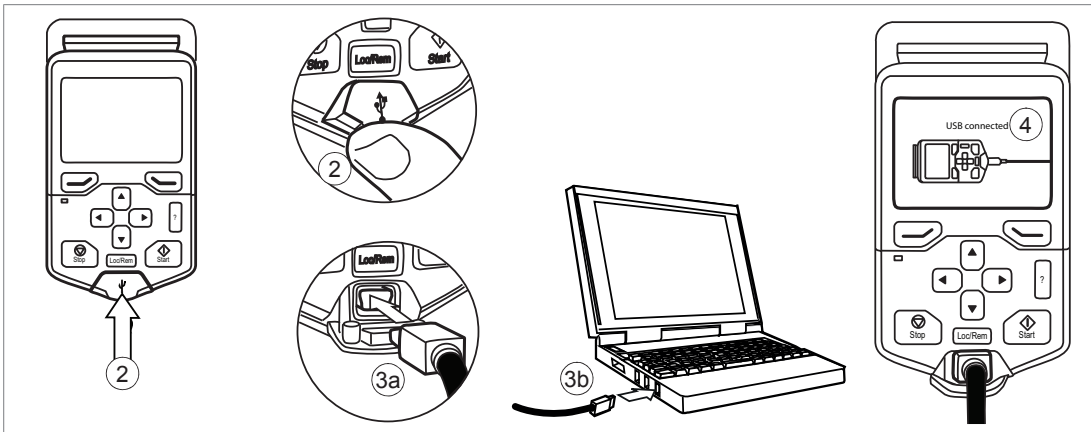

Alternatively, you can connect an Ethernet networking cable (eg. Cat 5e) to the Ethernet port behind the control panel. Make sure that the control panel is placed on a platform or a DIN rail.

Installing option modules

Note: The instructions in this section are applicable to drives with ZCU control unit. For UCU-20 control unit related instructions, refer to [UCU-20 control unit hardware manual \(3AXD50001079246 \[English\]\)](#).

■ Installing the FSO-xx safety functions module

Install the FSO safety functions module in Slot 2 of the control unit as described below.



WARNING Obey the safety instructions of the drive. If you ignore them, injury or death, or damage to the equipment can occur.

1. Stop the drive and do the steps in section [Electrical safety precautions \(page 18\)](#) before you start the work.
2. If the bottom plate of the FSO-xx module looks different from that in the drawing below, remove the bottom plate and attach the alternative bottom plate from the FSO package to module.
3. Connect the FSO-xx data cable to connector X12 on the control unit.
4. Attach the FSO-xx module to Slot 2 with four screws.
5. Tighten the FSO module electronics grounding screw to 0.8 N·m. Note: The screw tightens the connections and grounds the module. It is essential for fulfilling the EMC requirements and for proper operation of the module.

6. Connect the FSO-xx data cable to FSO-xx connector X110.
7. Connect the Safe torque off four-wire cable to connector X111 on the module and to connector XSTO on the drive module control unit.
8. Connect the external +24 V power supply cable to connector X112.
9. Connect the other wires as shown in [FSO-12 safety functions module user's manual \(3AXD50000015612 \[English\]\)](#) or [FSO-21 safety functions module user's manual \(3AXD50000015614 \[English\]\)](#).

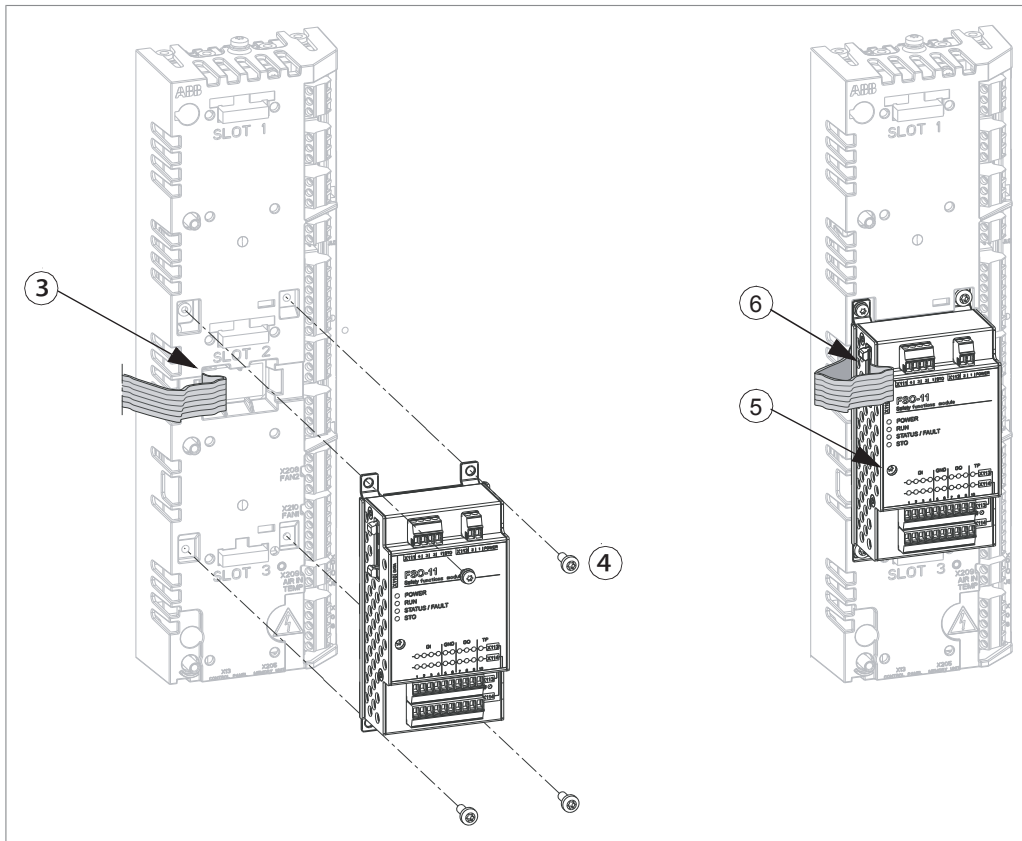

■ Installing the FSPS-21 PROFIsafe safety functions module

To install the FSPS-21 PROFIsafe safety functions module onto the drive control unit, refer to [FSPS-21 PROFIsafe safety functions module user's manual \(3AXD50000158638 \[English\]\)](#).

■ Installing the FSCS-21 CIP Safety™ functions module

To install the FSCS-21 CIP Safety™ functions module onto the drive control unit, refer to [FSCS-21 CIP Safety™ functions module user's manual \(3AXD50001065478 \[English\]\)](#).

■ Installing I/O extension, fieldbus adapter and pulse encoder interface modules

Note: Slot 3 of the control unit supports only small F-type option modules. These are +Kxxx, +L503, +L508, +Q986 and +Q989.

See [Overview of power and control connections \(page 38\)](#) for the available slots for each module.



WARNING Obey the safety instructions of the drive. If you ignore them, injury or death, or damage to the equipment can occur.

1. Stop the drive and do the steps in section [Electrical safety precautions \(page 18\)](#) before you start the work.
2. Insert the module carefully into its position on the control unit.
3. Tighten the grounding screw torque of 0.8 N·m.

Note: The screw tightens the connections and grounds the module. It is essential for fulfilling the EMC requirements and for correct operation of the module.

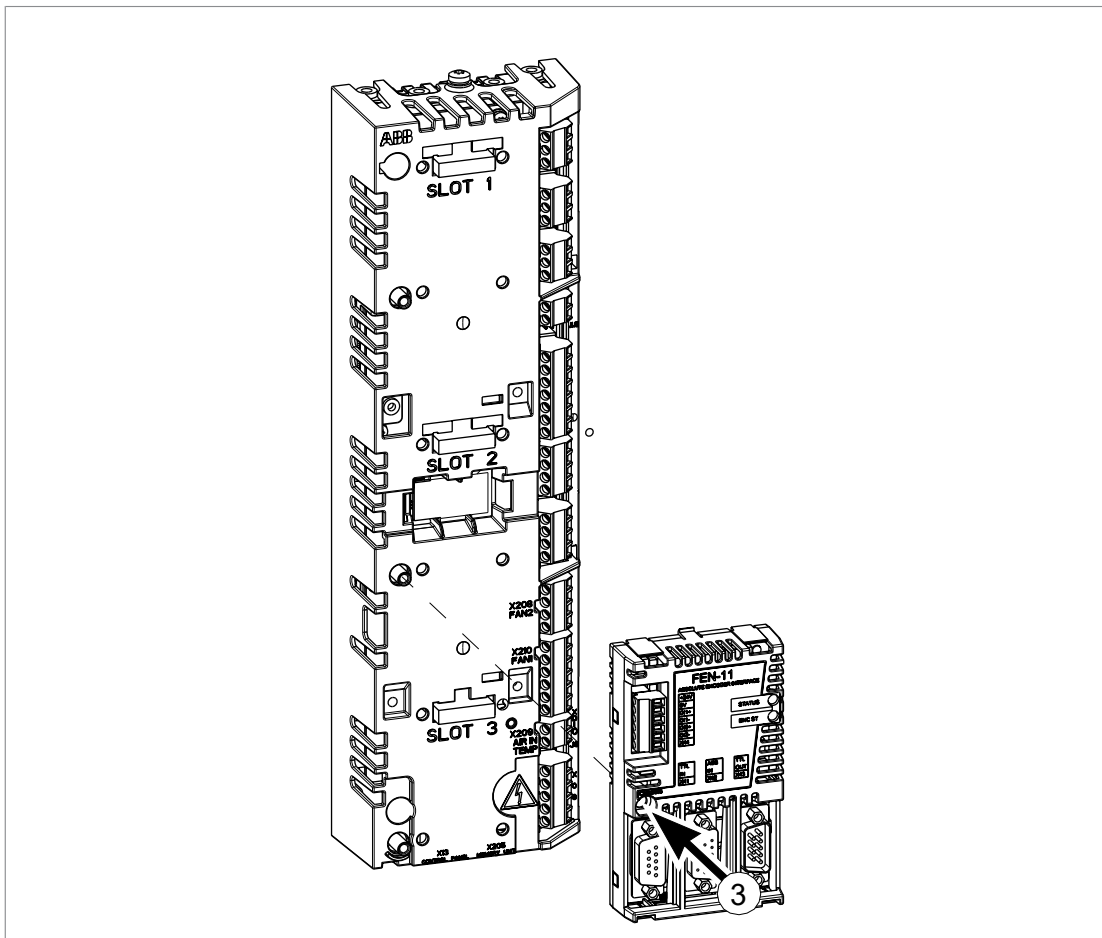

■ Wiring the option modules

See the appropriate option module manual for specific installation and wiring instructions.



Control unit

Contents of this chapter

This chapter

- gives information on the connections of the control unit, and
- has the specifications of the inputs and outputs of the control unit.

General

The drive uses ZCU-14 control unit. UCU-20 control unit is available with plus code +V998. For more information on the UCU-20 control unit, refer to [UCU-20 control unit hardware manual \(3AXD50001079246 \[English\]\)](#).

ZCU-14 layout

This figure shows the layout of the ZCU-14 control unit.

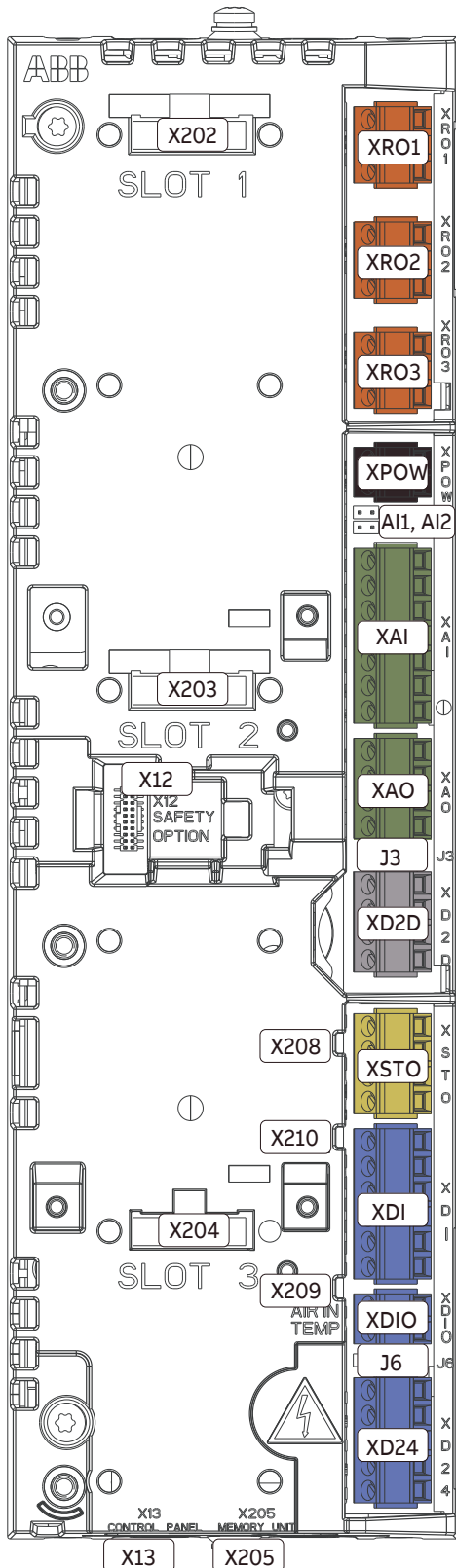

	Description
XPOW	External power input
XAI	Analog inputs
XAO	Analog outputs
XD2D	Drive-to-drive link or Modbus/RTU
XRO1	Relay output RO1
XRO2	Relay output RO2
XRO3	Relay output RO3
XD24	Digital input interlock (DIIL) and +24 V output
XDIO	Digital input/outputs
XDI	Digital inputs
XSTO	Safe torque off connection (inverter unit only). Note: This connection only acts as a true Safe torque off input when the ZCU is controlling an inverter unit. When the ZCU is controlling a supply unit, de-energizing the inputs will stop the unit but will not constitute a true safety function.
X12	Connection for FSO safety functions module (inverter unit only).
X13	Control panel connection
X202	Option slot 1
X203	Option slot 2
X204	Option slot 3
X205	Memory unit connection
X208	Cooling fan 1 connection
X209	Connection for ambient temperature sensor (at air inlet). Connected at the factory.
X210	Cooling fan 2 connection
AI1, AI2	Voltage/Current selection jumpers (AI1, AI2) for analog inputs
J3	Drive-to-drive link termination switch (J3)
J6	Common digital input ground selection jumper (J6).

Default control connection diagram of the drive control unit (ZCU)

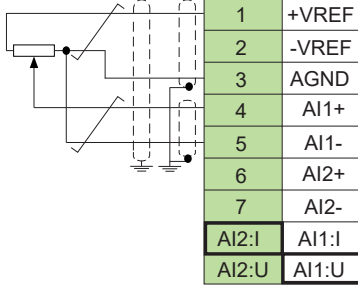
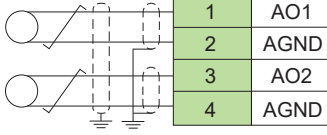
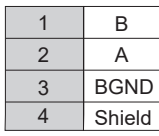
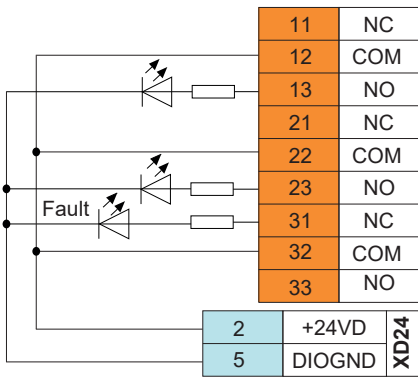
Connection	Term	Description
XPOW External power input		
	+24VI	24 V DC, 2 A min. (without optional modules)
	GND	
XAI Reference voltage and analog inputs		
	1 +VREF	+VREF 10 V DC, R_L 1...10 kohm
	2 -VREF	-VREF -10 V DC, R_L 1...10 kohm
	3 AGND	AGND Ground
	4 AI1+	AI1+ Speed reference
	5 AI1-	AI1- 0(2)...10 V, $R_{in} > 200$ kohm ¹⁾
	6 AI2+	AI2+ By default not in use.
	7 AI2-	AI2- 0(4)...20 mA, $R_{in} = 100$ ohm ¹⁾
	AI2:I AI1:I	J1 Current (I) / voltage (U) selection jumper for AI1
	AI2:U AI1:U	J2 Current (I) / voltage (U) selection jumper for AI2
	XAO Analog outputs	
	1 AO1	AO1 Motor speed rpm
	2 AGND	AGND 0...20 mA, $R_L < 500$ ohm
	3 AO2	AO2 Motor current
	4 AGND	AGND 0...20 mA, $R_L < 500$ ohm
XD2D Drive-to-drive link		
	B	Master/follower, drive-to-drive or embedded fieldbus connection
	A	
	BGND	
	Shield	
	J3	Drive-to-drive link termination
XRO1, XRO2, XRO3 Relay outputs		
	11 NC	NC Ready run
	12 COM	COM 250 V AC / 30 V DC
	13 NO	NO 2 A
	21 NC	NC Running
	22 COM	COM 250 V AC / 30 V DC
	23 NO	NO 2 A
	31 NC	NC Fault (-1)
	32 COM	COM 250 V AC / 30 V DC
	33 NO	NO 2 A
	2 +24VD	COM
5 DIOGND	NO	

124 Control unit

Connection	Term	Description
XD24 Auxiliary voltage output, digital interlock		
	DIIL	Run enable
	+24VD	+24 V DC 200 mA ²⁾
	DICOM	Digital input ground
	+24VD	+24 V DC 200 mA ²⁾
	DIOGND	Digital input/output ground
XDIO Digital input/outputs		
	DIO1	Output: Ready run
	DIO2	Output: Running
	J6	Ground selection ³⁾
XDI Digital inputs		
	DI1	Stop (0) / Start (1)
	DI2	Forward (0) / Reverse (1)
	DI3	Reset
	DI4	Acc/Dec time select ⁴⁾
	DI5	Constant speed 1 (1 = On) ⁵⁾
	DI6	By default, not in use.
XSTO Safe torque off connection		
	OUT	IN1 and IN2 are connected to OUT at the factory. To enable start and operation, IN1 and IN2 must be connected to OUT. Refer to chapter The Safe torque off function (page 233) .
	SGND	
	IN1	
	IN2	
X12	Safety options connection	
X13	Control panel connection	
X205	Memory unit connection	

¹⁾ Current [0(4)...20 mA, $R_{in} = 100 \text{ ohm}$] or voltage [0(2)...10 V, $R_{in} > 200 \text{ kohm}$] input selected by jumper. Change of setting requires reboot of control unit.

²⁾ Total load capacity of these outputs is 4.8 W (200 mA at 24 V) minus the power taken by DIO1 and DIO2.

³⁾ Determines whether DICOM is separated from DIOGND (ie. common reference for digital inputs floats; in practice, selects whether the digital inputs are used in current sinking or sourcing mode). See also [ZCU ground isolation diagram \(page 129\)](#). DICOM=DIOGND ON: DICOM connected to DIOGND. OFF: DICOM and DIOGND separate.

⁴⁾ 0 = Acceleration/deceleration ramps defined by parameters 23.12/23.13 in use. 1 = Acceleration/deceleration ramps defined by parameters 23.14/23.15 in use.

⁵⁾ Constant speed 1 is defined by parameter 22.26.

Additional information on the connections

■ Connecting motor temperature sensors to the drive

Refer to the electrical planning instructions.

■ Power supply for the control unit (XPOW)

Connect a power supply to the control unit through terminal block XPOW.

Refer to the control unit connector data for the current and voltage ratings of the power supply.

Connect an additional external power supply to the free +24 V and GND terminals of the XPOW terminal block if:

- the control unit must be kept operational during input power breaks, for example, because of continuous fieldbus communication
- immediate restart is necessary after a power break (that is, no control unit power-up delay is permitted).

■ Digital interlock (DIIL)

Digital interlock input (DIIL) terminal is originally intended for interlock signals that stop the drive/unit when necessary. In the ACS880 primary control program, DIIL terminal is the source for the run enable signal by default. The inverter unit or drive cannot start, or it stops when there is no DIIL signal. In other control programs (and units), the default use of the DIIL terminal varies. Refer to the firmware manual for more information.

Note: This input is **not** SIL or PL classified.

■ The XD2D connector

The XD2D connector provides an RS-485 connection that can be used for

- basic master/follower communication with one master drive and multiple followers,
- fieldbus control through the embedded fieldbus interface (EFB), or
- drive-to-drive (D2D) communication implemented by application programming.

See the firmware manual for the related parameter settings.

Terminate the bus on the units at the ends of the drive-to-drive link. Disable bus termination on the intermediate units.

Use a shielded twisted-pair cable for data, and another pair or a wire for signal ground (nominal impedance 100...165 ohm, for example Belden 9842). For the best immunity, ABB recommends high quality cable. Keep the cable as short as possible. Avoid unnecessary loops and parallel runs near power cables such as motor cables.

The diagram that follows shows the wiring of the drive-to-drive link. The diagram is applicable to these control units:

- ZCU-14

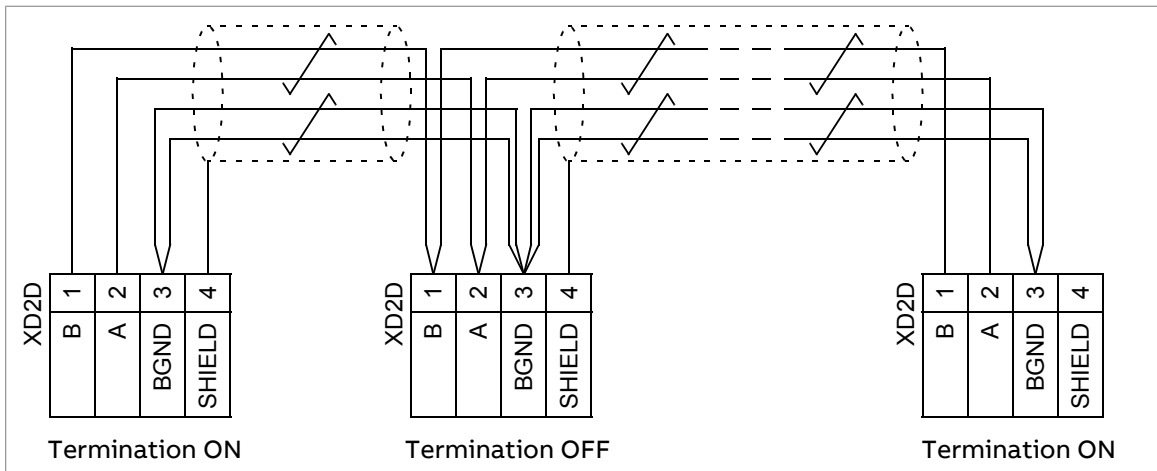

■ Safe torque off (XSTO)

The XSTO input only acts as a true Safe torque off input on the inverter control unit. De-energizing the STO input terminals of other control units (supply, DC/DC converter, or brake unit) stops the unit but does not constitute a SIL/PL classified safety function.

■ Safety functions module connection (X12)

In drives or inverter units with a compatible control program, an optional FSO safety functions module can be connected to the X12 connector. The control program in supply, brake, and DC/DC converter units does not support the FSO safety functions module.

For more information on the FSO safety functions module, refer to the applicable FSO module user's manual.

Note: Inverter modules and control units that have a sticker with the text “No FSO support” are not compatible with the FSO safety functions module.

Connector data

This data applies also to integrated control unit (option +P905) connectors.

The wire size accepted by all screw terminals (for both stranded and solid wire) is 0.5 ... 2.5 mm² (22...12 AWG). Connector pitch is 5 mm.

The maximum tightening torque for screw terminals is 0.5 N·m (5 lbf·in).

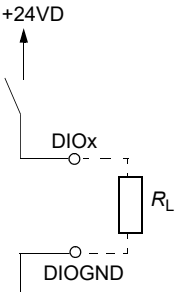
Power supply (XPOW)	24 V DC ($\pm 10\%$), 2 A External power input.
Relay outputs RO1...RO3 (XRO1...XRO3)	250 V AC / 30 V DC, 2 A Protected by varistors
+24 V output (XD24:5 and XD24:7)	Total load capacity of these outputs is 4.8 W (200 mA / 24 V) minus the power taken by DIO1 and DIO2.
Digital inputs DI1...DI6 (XDI:1...XDI:6)	24 V logic levels: "0" < 5 V, "1" > 15 V R_{in} : 2.0 kohm (DI1...DI5) Input type: NPN/PNP (DI1...DI5), PNP (DI6) Hardware filtering: 0.04 ms, digital filtering up to 8 ms I_{max} : 15 mA (DI1...DI5), 5 mA (DI6)
Start interlock input DIIL (XD24:1)	24 V logic levels: "0" < 5 V, "1" > 15 V R_{in} : 2.0 kohm Input type: NPN/PNP Hardware filtering: 0.04 ms, digital filtering up to 8 ms
Digital inputs/outputs DIO1 and DIO2 (XDIO:1 and XDIO:2) Input/output mode selection by parameters. DIO1 can be configured as a frequency input (0...16 kHz with hardware filtering of 4 microseconds) for 24 V level square wave signal (sinusoidal or other wave form cannot be used). In some control programs, DIO2 can be configured as a 24 V level square wave frequency output. Refer to the firmware manual, parameter group 11.	<u>As inputs:</u> 24 V logic levels: "0" < 5 V, "1" > 15 V. R_{in} : 2.0 kohm. Filtering: 1 ms. <u>As outputs:</u> Total output current from +24VD is limited to 200 mA 
Reference voltage for analog inputs +VREF and -VREF (XAI:1 and XAI:2)	10 V $\pm 1\%$ and -10 V $\pm 1\%$, R_{load} 1...10 kohm Maximum output current: 10 mA
Analog inputs AI1 and AI2 (XAI:4 ... XAI:7). Current/voltage input mode selection by jumpers	Current input: -20...20 mA, R_{in} = 100 ohm Voltage input: -10...10 V, R_{in} > 200 kohm Differential inputs, common mode range ± 30 V Sampling interval per channel: 0.25 ms Hardware filtering: 0.25 ms Resolution: 11 bit + sign bit Inaccuracy: 1% of full scale range
Analog outputs AO1 and AO2 (XAO)	0...20 mA, R_{load} < 500 ohm Frequency range: 0...300 Hz Resolution: 11 bit + sign bit Inaccuracy: 2% of full scale range

128 Control unit

XD2D connector	<p>Physical layer: RS-485</p> <p>Transmission rate: 8 Mbit/s</p> <p>Cable type: Shielded twisted-pair cable with a twisted pair for data and a wire or another pair for signal ground (nominal impedance 100 ... 165 ohm, for example Belden 9842)</p> <p>Maximum length of link: 50 m (164 ft)</p> <p>Termination by jumper</p>
RS-485 connection (X485)	<p>Physical layer: RS-485</p> <p>Cable type: Shielded twisted-pair cable with a twisted pair for data and a wire or another pair for signal ground (nominal impedance 100 ... 165 ohm, for example Belden 9842)</p> <p>Maximum length of link: 50 m (164 ft)</p>
Safe torque off connection (XSTO)	<p>Input voltage range: -3...30 V DC</p> <p>Logic levels: "0" < 5 V, "1" > 17 V.</p> <p>Note: Both circuits must be closed to enable start and operation (IN1 and IN2 must be connected to OUT). This applies to all control units (including drive, inverter, supply, brake, DC/DC converter etc. control units), but SIL/PL classified Safe torque off functionality is only achieved through the XSTO connector of the drive/inverter control unit.</p> <p>Current consumption: 66 mA (continuous) per STO channel</p> <p>EMC (immunity) according to IEC 61326-3-1 and IEC 61800-5-2</p>
Control panel connection (X13)	<p>Connector: RJ-45</p> <p>Cable length < 100 m (328 ft)</p>
<p>The terminals of the control unit fulfill the Protective Extra Low Voltage (PELV) requirements. The PELV requirements of a relay output are not fulfilled if a voltage higher than 48 V is connected to the relay output.</p>	

■ ZCU ground isolation diagram

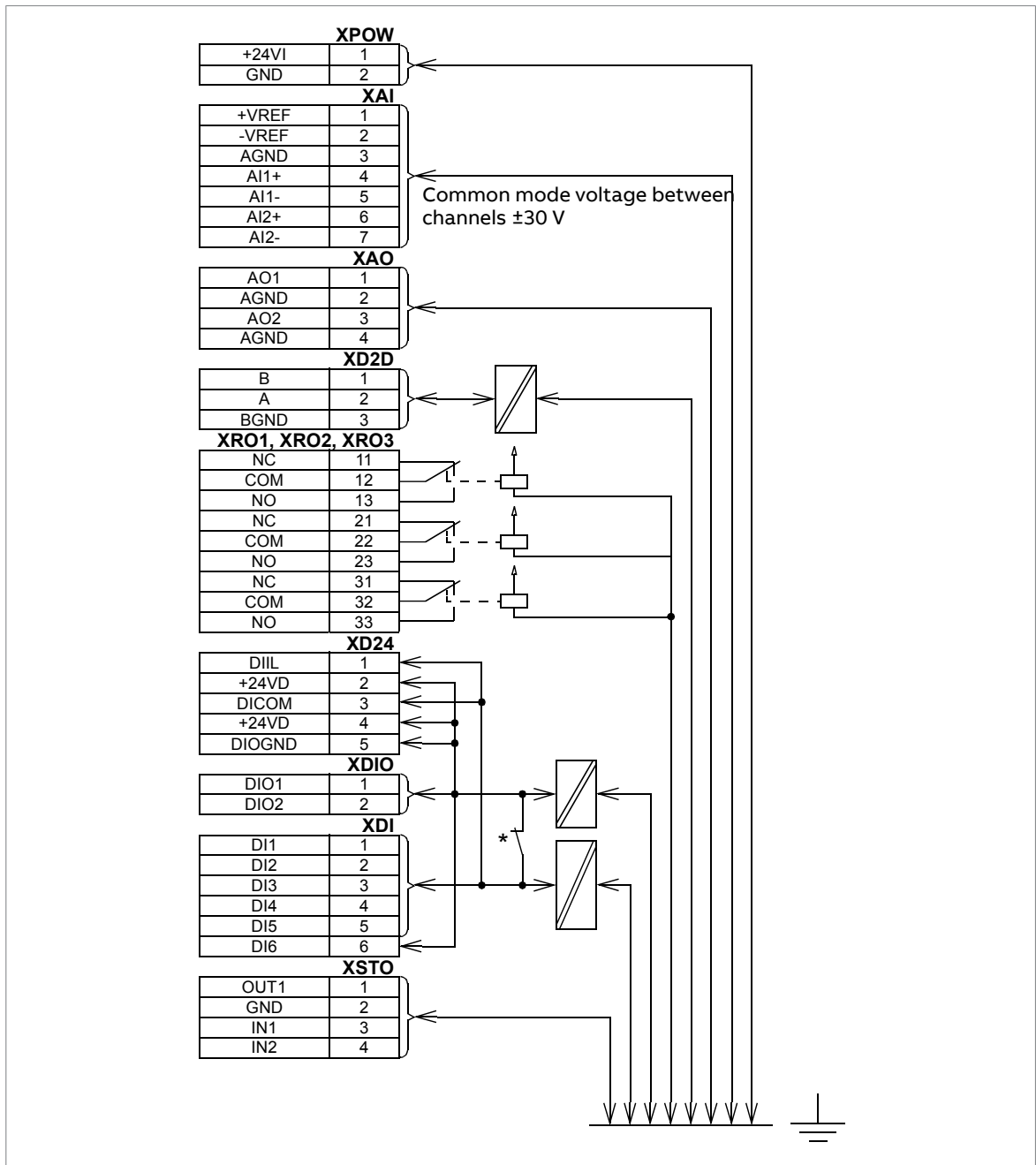

* Ground selector (J6) settings



All digital inputs share a common ground (DICOM connected to DIOGND). This is the default setting.



Ground of digital inputs DI1...DI5 and DIIL (DICOM) is isolated from DIO signal ground (DIOGND). Isolation voltage 50 V.

9

Installation example 1 - Bookshelf installation in a 600 mm enclosure

Contents of this chapter

In this chapter, the drive module is installed in a 600 mm wide Rittal VX25 enclosure in a bookshelf way of mounting. The module is placed in an upright position on the enclosure bottom with its front facing the enclosure door. Available alternative ABB parts are also given.

Limitation of liability

The installation must always be designed and made according to applicable local laws and regulations. ABB does not assume any liability whatsoever for any installation which breaches the local laws and/or other regulations. Furthermore, if the recommendations given by ABB are not followed, the drive may experience problems that the warranty does not cover.

■ North America

Installations must be compliant with NFPA 70 (NEC)¹⁾ and/or Canadian Electrical Code (CE) along with state and local codes for your location and application.

¹⁾ National Fire Protection Association 70 (National Electric Code).

Required parts

Drive module standard parts		
<ul style="list-style-type: none"> • Drive module • Fastening bracket • Pedestal guide plate • Telescopic extraction and insertion ramp • Fastening screws and insulators in a plastic bag • External control unit 		
Rittal parts / Alternative ABB parts		
Rittal part code	Qty (pcs)	Description
VX 8606.000	1	Enclosure frame with one front door, rear panel, mounting plate, roof plate, divided gland plates.
DK 7967.000 (one set = four pieces) ABB 3AUA0000117003 (IP20) ABB 3AUA0000117008 (IP42)	1	Spacers for roof plates. / ABB roof Note: For alternative ABB outlet kits, see section Air outlet kits (page 178) .
VX 8617.030	5	Punched section with mounting flange, outer mounting level for 600 mm horizontal
TS 4396.500		Support rails
SK 3243.200 / ABB 3AUA0000117003 (IP20) ABB 3AUA0000117008 (IP42)	4 / 2	Air filter 323 mm × 323 mm. Remove the filter mats. Note: For alternative ABB air filters, see section Air inlet kits (page 176) .
Customer-made parts (not ABB or Rittal products)		
Air baffles	2	See Layout example, door open (standard drive module configuration) (page 46) .

Required tools

- Set of screw drivers (Torx and Pozidriv)
- Set of metric magnetic-end hexagon sockets
- Torque wrench
- Step drill bit for drilling the holes in the clear plastic shroud for input power cables.

Overall flowchart of the installation process

Step	Task	For instructions, see
1	Install the Rittal parts, drive bottom guide plate and loose drive options in the drive module cubicle	Installing the drive module into the enclosure (page 133) and installation drawings
2	Install the auxiliary components (such as mounting plates, air baffles, switches, busbars etc.)	The component manufacturer's instructions Air baffles for the standard drive module and option +C173 (page 227)
3	Attach the drive module to the enclosure	Step-by-step drawings for an installation example of standard drive configuration with option +E208 in Rittal VX25 600 mm wide enclosure (page 261)
4	Connect the power cables and install the clear plastic shrouds to the drive module	Connecting the power cables and installing the shrouds (page 134)

Step	Task	For instructions, see
5	Install the external control unit	Attaching the external control unit (page 67)
6	Connect the control cables	Connecting the control cables to the terminals of the external control unit (page 112)
7	Install the remaining parts, for example enclosure doors, side plates, etc.	The component manufacturer's instructions Installing the roof and door (Rittal parts) (page 135)

Installing the drive module into the enclosure

See [Step-by-step drawings for an installation example of standard drive configuration with option +E208 in Rittal VX25 600 mm wide enclosure \(page 261\)](#) and [ACS880-04 quick installation guide \(3AXD50000009366 \[English\]\)](#).

- Install the punched section to the back of the enclosure frame.
 - Install the bottom grille to the drive module for IP20 degree of protection from bottom if there is no leak-proof bottom plate in the enclosure.
 - Install the support rails and pedestal guide plate to the enclosure bottom frame.
 - Install the telescopic insertion ramp to the pedestal guide plate.
 - Remove the sheeting from the clear plastic shrouds from both sides.
 - Install the top metallic shroud to the drive module.
 - Install the back shrouds to the drive module.
 - To prevent the drive module from falling, attach its lifting lugs with chains to the enclosure frame.
 - Push the drive module carefully into the enclosure along the telescopic insertion ramp.
 - Remove the ramp.
 - Attach the drive module to the pedestal guide plate.
 - Attach the drive module from top to the punched section at the enclosure back.
- Note:** The fastening bracket grounds the drive module to the enclosure frame.
- Install the air baffles.
-

Connecting the power cables and installing the shrouds

Step	Task (motor cables)
1	Install the grounding terminal to the drive module base.
2	Run the motor cables to the enclosure. Ground the cable shields 360 degrees at the enclosure entry.
3	Connect the twisted shields of the motor cables to the grounding terminal.
4	Screw in and tighten the insulators to the drive module by hand. Install the T3/W2 connection terminal to the insulators.  WARNING Do not use longer screws or more tightening torque than the installation drawing shows. Screws that are too long and excessive torque can cause damage to the insulator and cause dangerous voltage to be present at the module frame.
5	Connect the phase T3/W2 conductors to the T3/W2 terminal.
6	Install the T2/V2 connection terminal to the insulators. See the warning in step 4.
7	Connect the phase T2/V2 conductors to the T2/V2 connection terminal.
8	Install the T1/U2 connection terminal to the insulators. See the warning in step 4.
9	Connect the phase T1/U2 conductors to the T1/U2 terminal.
10	Remove the plastic sheeting from the output clear plastic shrouds from both sides.
11	Install the shrouds to the drive module.
12	Install the lower front cover to the drive module.

Step	Task (input cables)
1	Ground the input cable shields (if present) 360 degrees at the enclosure entry.
2	Connect the twisted shields of the input cables and separate ground cable (if present) to the enclosure grounding busbar.
3	Step drill carefully sufficiently big holes to the entry clear plastic shroud for the cables to be connected. Align the holes in the vertical direction according to the alignment holes in the shroud. Smooth the hole edges. Remove the plastic sheeting from both sides of the shroud. Attach the cables firmly to the enclosure frame to prevent chafing against the hole edges.
4	Put the conductors of the input cables through the drilled holes in the clear plastic shroud.
5	<u>For drive modules without option +H370:</u> Connect the input cable conductors to the drive module L1/U1, L2/V1 and L3/W1 connection busbars, Go to step 12.
For option +H370: Do steps 6 to 11.	
6	Screw in and tighten the insulators to the drive module by hand. Install the L1/U1 connection terminal to the insulators.  WARNING Do not use longer screws or more tightening torque than the installation drawing shows. Screws that are too long and excessive torque can cause damage to the insulator and cause dangerous voltage to be present at the module frame.
7	Connect the L1/U1 conductors to the L1/U1 connection terminal.
8	Install the L2/V1 connection terminal to the insulators. See the warning in step 6.
9	Connect the L2/V1 conductors to the L2/V1 connection terminal.
10	Install the L3/W1 connection terminal to the insulators. See the warning in step 6.
11	Connect the L3/W1 conductors to the L3/W1 connection terminal.
12	Install the entry clear plastic shroud. Install the front clear plastic shroud and upper front cover.
13	Install the side and top clear plastic shrouds to the drive module.

Installing the roof and door (Rittal parts)

This drawing shows a layout tested by ABB.

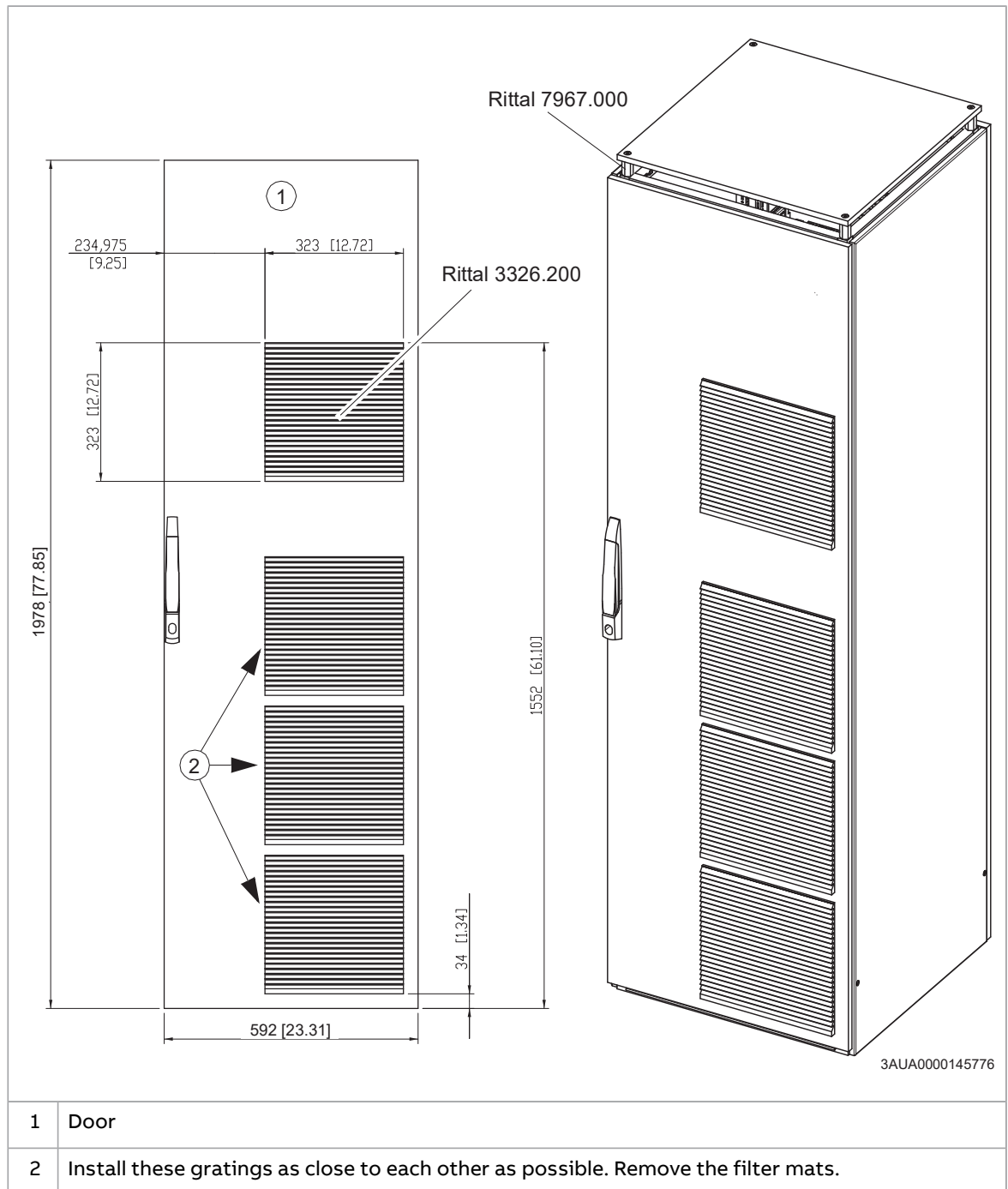

Installing the roof and door (ABB air filters and roof)

This drawing shows a layout tested by ABB.

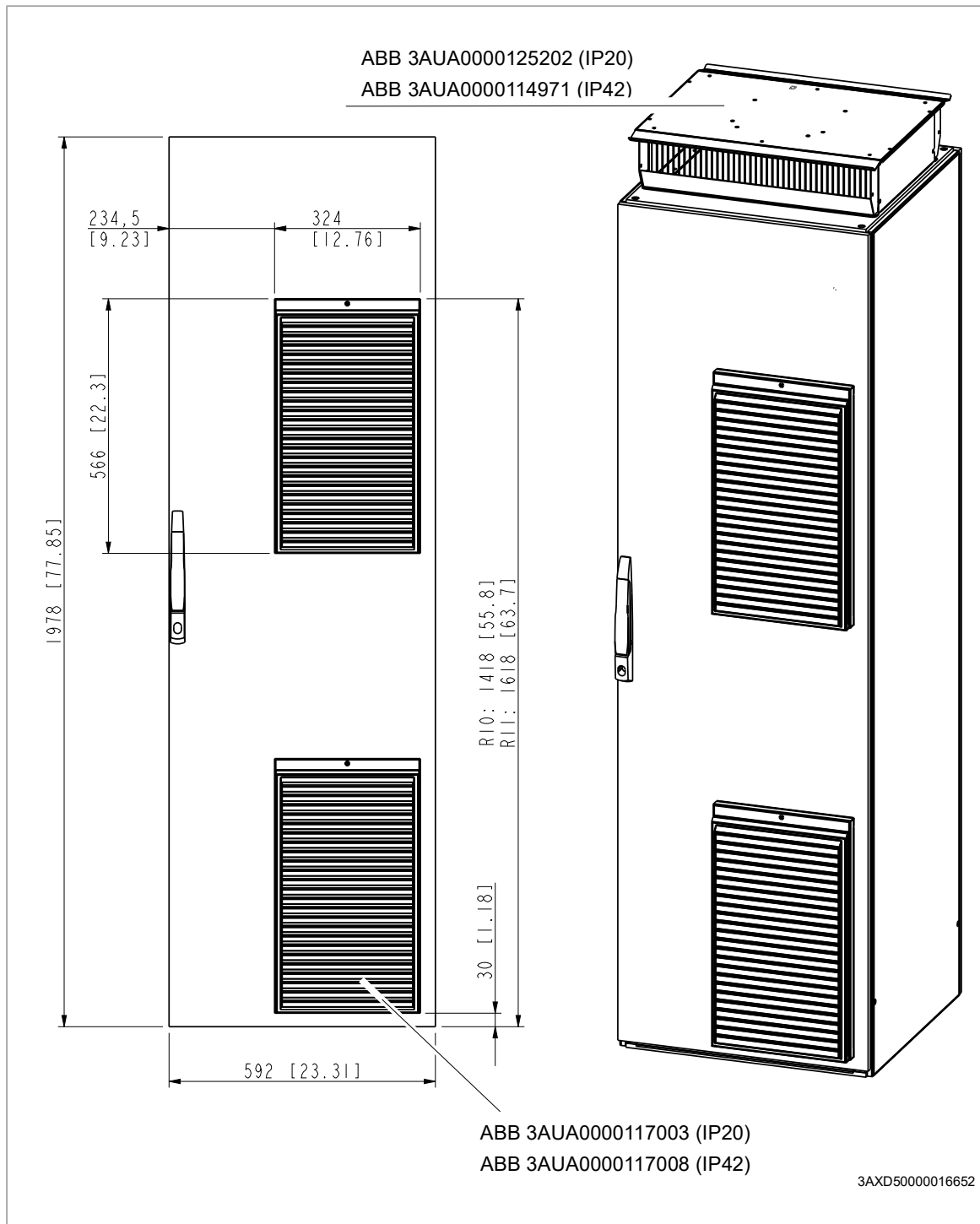

Removing the protective covering from the drive module air outlet



WARNING Remove the protective cover from the top of the module after the module is installed. The protective cover prevents cooling airflow and can cause the module to overheat.



Miscellaneous

■ Input power cable entry from top

If you run the input cables from top to the drive module, drill the entry holes to the top clear plastic shroud.

■ Attaching the drive module to a mounting plate or wall

Use the support bracket 3AUA0000096082 (included in the assembly kit 3AXD50000453900) if you attach the drive module directly to a mounting plate or wall. The support bracket prevents the drive module screws from chafing against the plate.

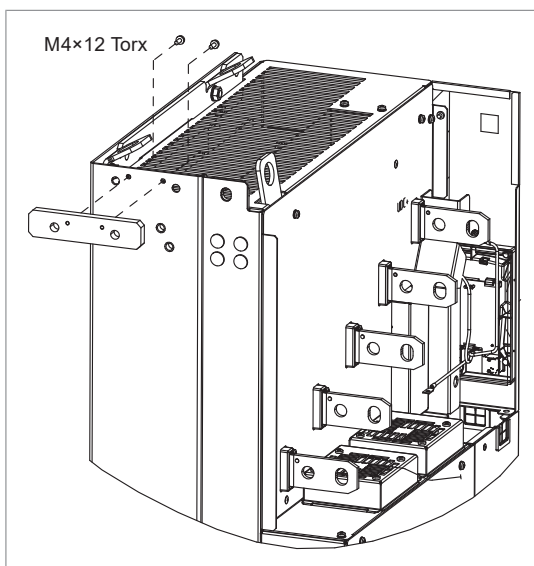

10

Installation example 2 - Bookshelf installation in a 400 mm enclosure

Contents of this chapter

In this chapter, the drive module is installed into a 400 mm wide Rittal VX25 enclosure in a bookshelf way of mounting. The module is placed in an upright position on the enclosure bottom with its front facing the enclosure door. Space for the additional components can be made by connecting two or more VX25 enclosures together. Available alternative ABB parts are also given.

Limitation of liability

The installation must always be designed and made according to applicable local laws and regulations. ABB does not assume any liability whatsoever for any installation which breaches the local laws and/or other regulations. Furthermore, if the recommendations given by ABB are not followed, the drive may experience problems that the warranty does not cover.

■ North America

Installations must be compliant with NFPA 70 (NEC)¹⁾ and/or Canadian Electrical Code (CE) along with state and local codes for your location and application.

¹⁾ National Fire Protection Association 70 (National Electric Code).

Required parts

Drive module standard parts		
<ul style="list-style-type: none"> • Drive module • Top guide plate • Fastening bracket • Grounding busbar • Pedestal guide plate • Telescopic extraction and insertion ramp • Fastening screws in a plastic bag • External control unit 		
Drive module options		
Option code	Qty (pcs)	Description
+H381	1	Full power cabling panels
+P905	1	integrated control unit (inside the drive module)
Rittal parts / Alternative ABB parts		
Rittal part code	Qty (pcs)	Description
VX 8406.000	1	Enclosure frame with one front door, rear panel, mounting plate, roof plate, divided gland plates.
VX 8106.245	1	Side panels for the enclosure
DK 7967.000 (one set = four pieces) ABB 3AUA0000125201 (IP20) ABB 3AUA0000114967 (IP42)	1	Spacers for roof plate / ABB roof Note: For alternative ABB outlet kits, see section Air outlet kits (page 178) .
VX 8617.030	5	Punched section with mounting flange, outer mounting level for 600 mm horizontal
VX 8617.010	3	Punched section with mounting flange, outer mounting level for 400 mm horizontal
SK 3243.200 / ABB 3AUA0000117002 (IP20) ABB 3AUA0000117007 (IP42)	4 / 2	Air filter 323 mm × 323 mm. Remove the filter mat according to the manufacturer's instructions. Note: For alternative ABB air filters, see section Air inlet kits (page 176) .
TS 4396.500	3	Support rail (alternative to a customer-made bottom plate)
Customer-made parts (not ABB or Rittal products)		
Dimension drawing code	Qty (pcs)	Description
3AXD50000437368	2	Air baffles See section Air baffles for option +H381 in Rittal VX25 400 mm wide enclosure installation (page 228) for the dimension drawings of the air baffles required in the cabinet.
3AXD50000433988	1	Cabinet bottom plate (alternative to Rittal support rails) See section Bottom plate for option +H381 in Rittal VX25 400 mm wide enclosure installation (page 225) for the dimension drawing of a customer-made bottom plate.

Required tools

- Set of screw drivers (Torx and Pozidriv)
- Set of metric magnetic-end hexagon sockets
- Torque wrench with a 500 mm (20 in) or 2 × 250 mm (2 × 10 in) long socket extension.

Overall flowchart of the installation process

Step	Task	For instructions, see
1	Install the Rittal parts and drive module mechanical accessories into the enclosure	Installing the mechanical accessories into the enclosure (page 141) and Step-by-step drawings for installation example 2 - Bookshelf installation (option +H381) in a Rittal VX25 400 mm enclosure (page 265)
2	Connect the power cables to the cabling panels	Connecting the power cables (page 142)
3	Install the drive module into the enclosure	Installing the drive module into the enclosure (page 145)
4	Install the external control unit	Attaching the external control unit (page 67)
5	Connect the control cables	Connecting the control cables to the terminals of the external control unit (page 112)
6	Install the remaining parts, for example enclosure doors, side plates, air baffles, etc.	The component manufacturer's instructions Air baffles for option +H381 in Rittal VX25 400 mm wide enclosure installation (page 228)

Installing the mechanical accessories into the enclosure

Install the mechanical accessories into the enclosure as shown in [Step-by-step drawings for installation example 2 - Bookshelf installation \(option +H381\) in a Rittal VX25 400 mm enclosure \(page 265\)](#)

If you do not use Rittal support rails on the bottom of the enclosure but use a custom bottom plate instead, see the dimension drawings for the correct dimensions of the bottom plate.

If the thickness of the bottom plate is not 2.5 mm (0.1 in), adjust the dimensions accordingly.

Connecting the power cables

■ Power cable connection diagram

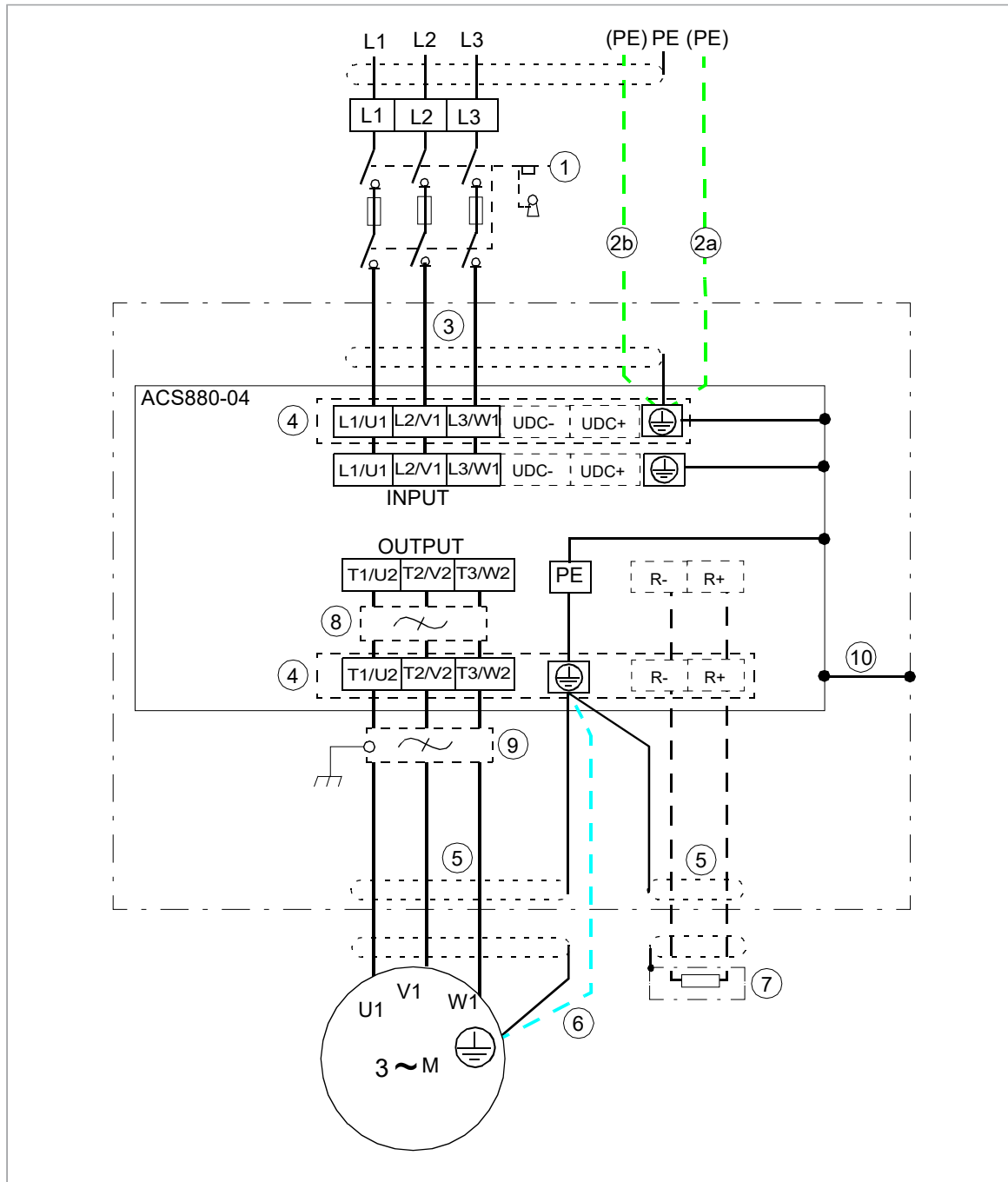

1	For alternatives, see section Selecting the main supply disconnecting device (page 73) . In the installing example of this chapter, the disconnecting device is not in the same cubicle with the drive module.
2	If a shielded cable is used (not required but recommended) and the conductivity of the shield is < 50% of the conductivity of the phase conductor, use a separate PE cable (2a) or a cable with a grounding conductor (2b).
3	ABB recommends 360-degree grounding at the cabinet entry if a shielded cable is used. Ground the other end of the input cable shield or PE conductor at the distribution board.
4	Input and output power cabling panels (option +H381).
5	ABB recommends 360-degree grounding at the cabinet entry.

6	Use a separate grounding cable if the conductivity of the cable shield is < 50% of the conductivity of the phase conductor and there is no symmetrically constructed grounding conductor in the cable, see section Power cable types (page 82) .
7	External brake resistor (optional, see Resistor braking (page 251))
8	Common mode filter (optional, see Requirements tables (page 75))
9	du/dt filter (optional, see du/dt filters (page 259))
10	The drive module frame must be connected to the cabinet frame. See section Alternatives for grounding the drive module (page 69) .

Note: If there is a symmetrically constructed grounding conductor in the motor cable in addition to the conductive shield, connect the grounding conductor to the grounding terminal at the drive and motor ends.

Do not use an asymmetrically constructed motor cable. Connecting its fourth conductor at the motor end increases bearing currents and causes extra wear.

■ Power cable connection procedure



▲WARNING Obey the safety instructions of the drive. If you ignore them, injury or death, or damage to the equipment can occur. If you are not a qualified electrical professional, do not do electrical installation, commissioning or maintenance work.

1. Run the motor cables from the motor to the enclosure. Ground the cable shields 360° at the entry plate.
2. Twist the cable shields of the motor cables into bundles and connect them and any separate ground conductors or cables to the ground terminal of the drive module or to the enclosure ground bar.
3. Connect the phase conductors of the motor cables to terminals T1/U2, T2/V2 and T3/W2 of the drive module. For the tightening torques, see the technical data.
4. Drive modules with option +D150: Run the power cables from the brake resistor to the cabinet. Ground the cable shield (if present) 360° at the entry plate. Connect the conductors to the R+ and R- terminals. For the tightening torques, see the technical data.
5. Make sure that all power is disconnected and reconnection is not possible. Use proper safe disconnect procedures according to local codes.
6. Run the input cables from the supply source to the enclosure. Ground the cable shields 360° at the entry plate.
7. Twist the cable shields of the input cables into bundles and connect them and any separate ground conductors or cables to grounding busbar of the input cabling panel.
8. Connect the phase conductors of the input cables to terminals L1/U1, L2/V1 and L3/W1 of the drive module. For the tightening torques, see the technical data.

An example installation is shown below.

144 Installation example 2 - Bookshelf installation in a 400 mm enclosure

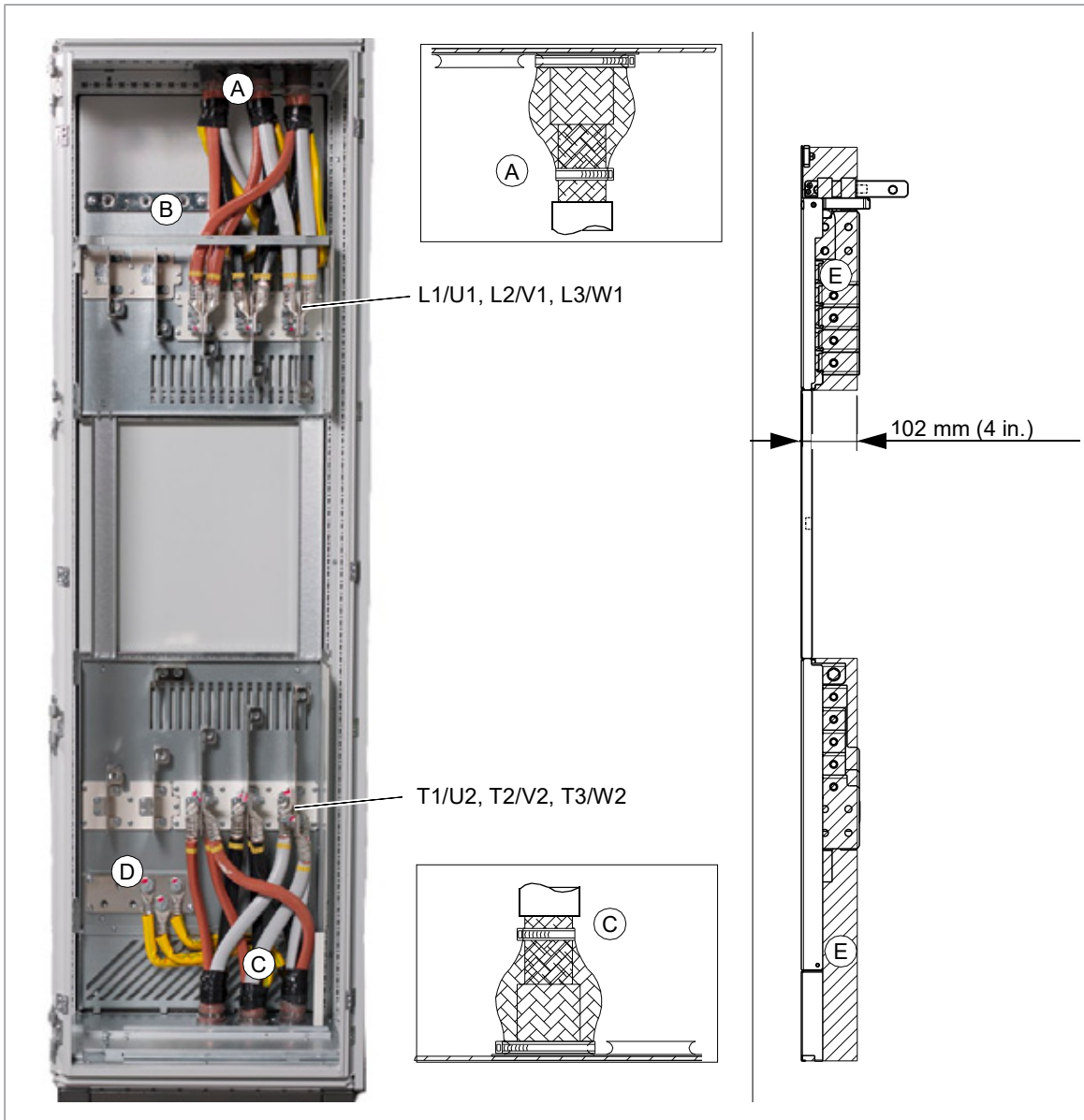

View without cabinet side plate in place.

A	360-degree grounding at the entry plate for the input power cables
B	Grounding busbar of the input power cabling panel
C	360-degree grounding at the entry plate for the output power cables
D	Grounding busbar of the output power cabling panel
E	Allowed space for power cables. The input and output power cables must fit inside the area marked with diagonal lines to prevent chafing of the cables when the drive module is inserted into the cabinet.

Installing the drive module into the enclosure



▲WARNING Obey the safety instructions of the drive. If you ignore them, injury or death, or damage to the equipment can occur.

Handle the drive module carefully. Make sure that the module does not fall down when moving it on the floor and during installation and maintenance work: To open the support legs, press each leg a little down and turn it aside (1, 2). When possible, also secure the module with chains from top.

Do not tilt the drive module (A). It is heavy and its center of gravity is high. The module will overturn from a sideways tilt of 5 degrees. Do not leave the module unattended on a sloping floor.

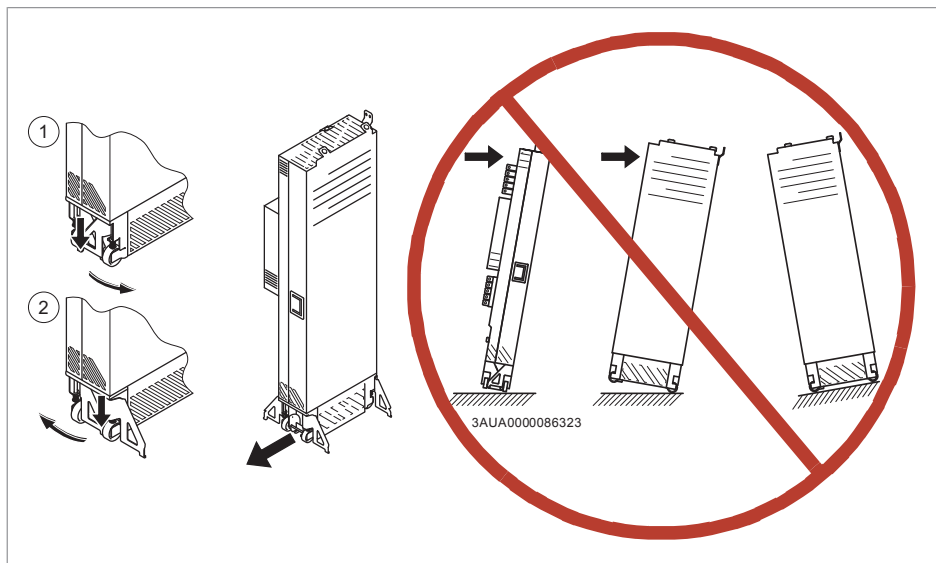

■ Installation procedure

1. Attach the mounting bracket to the drive module. The bracket will ground the drive module to the cabinet frame.

146 Installation example 2 - Bookshelf installation in a 400 mm enclosure

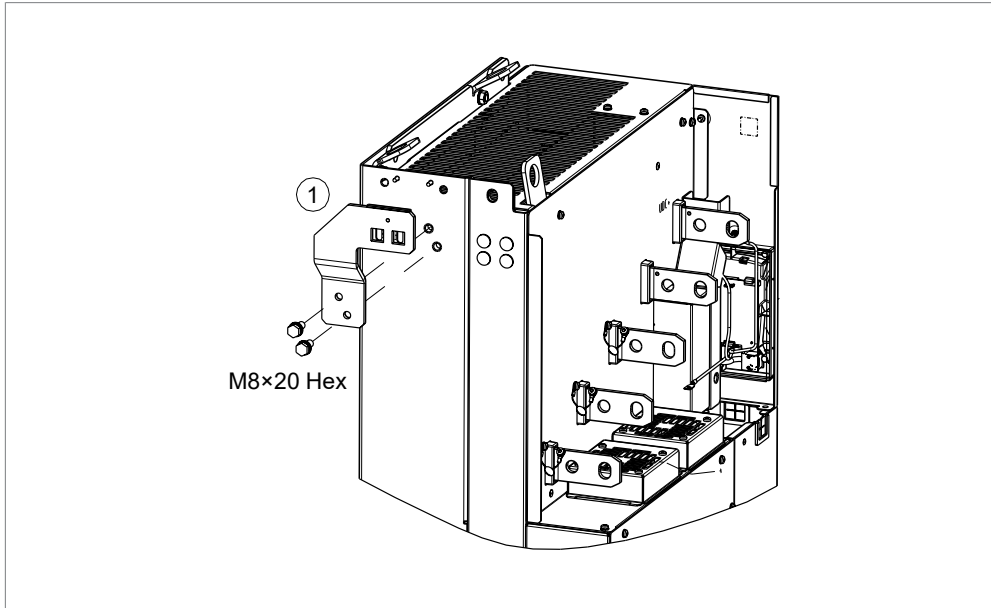

2. Install the telescopic extraction and insertion ramp to the cabinet base with two screws.
3. Remove the upper and lower left-hand side front covers of the drive module (M4x8 combi screws, 2 N·m [18 lbf·in]).
4. Attach the drive module lifting lugs to the enclosure frame with chains.
5. Push the drive module carefully into the enclosure preferably with the help from another person.
6. Attach the grounding busbar that has been previously attached to the input cabling panel to the drive module.

Note: The design of the grounding busbar can be different from what is shown in the figure.

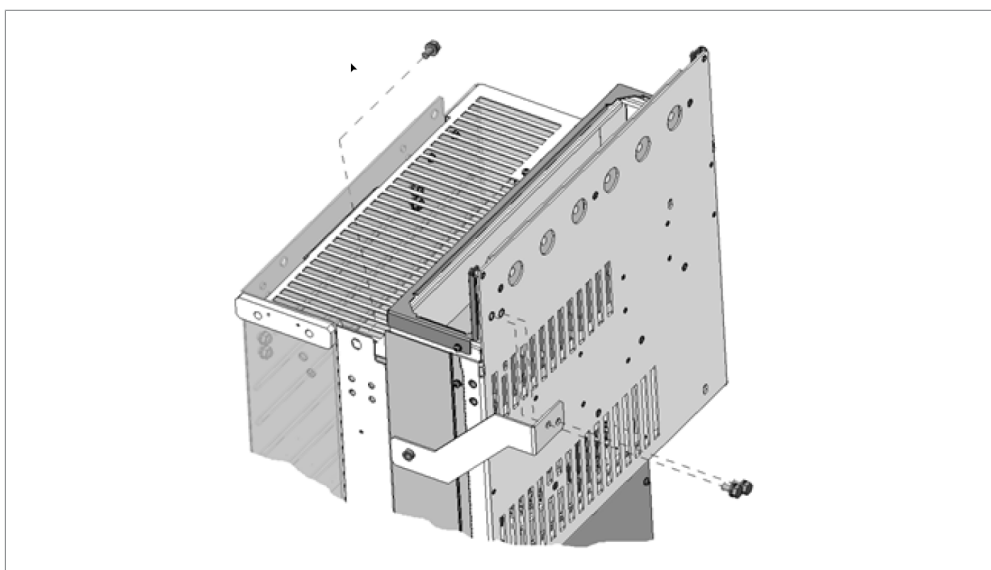

7. Connect the busbars of the drive module to the busbars of the cabling panels (M12 combi screw, 70 N·m [52 lbf·ft]).

8. Attach the drive module to the enclosure from top and bottom, see [Assembly drawing of installing the drive module to the enclosure \(frame R10\) \(page 149\)](#) (frame R10) or [Assembly drawing of installing the drive module to the enclosure \(frame R11\) \(page 150\)](#) (frame R11). The top fastening bracket grounds the drive module to the cabinet frame.
 9. Attach the cabinet roof on the spacers and the side panels, see [Assembly drawing of installing the roof and door \(page 151\)](#).
 10. Remove the filter mats from the air filters according to Rittal's instructions. Install the filters to the cabinet door, see [Assembly drawing of installing the roof and door \(page 151\)](#).
 11. Drive modules with an external control unit: Put back the removed front covers of the drive module on the power cable sections. Connect the control cables, see [Connecting the control cables to the terminals of the external control unit \(page 112\)](#).
Drive modules with an integrated control unit (option +P905): Connect the control cables to the control unit, see [Connecting the control cables to the integrated control unit \(options +P905 and +0B051\) \(page 114\)](#). Connect the control panel cable and put back the removed front covers of the drive module.
-

148 Installation example 2 - Bookshelf installation in a 400 mm enclosure

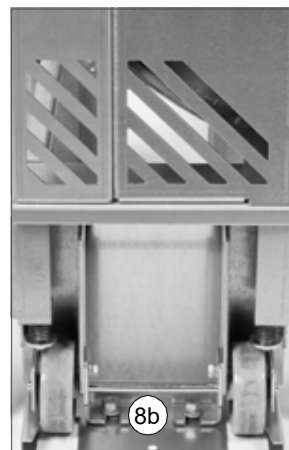
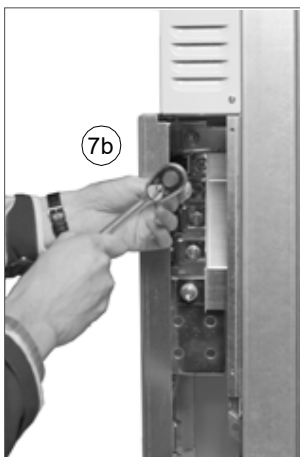
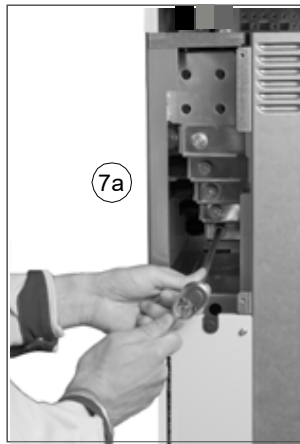
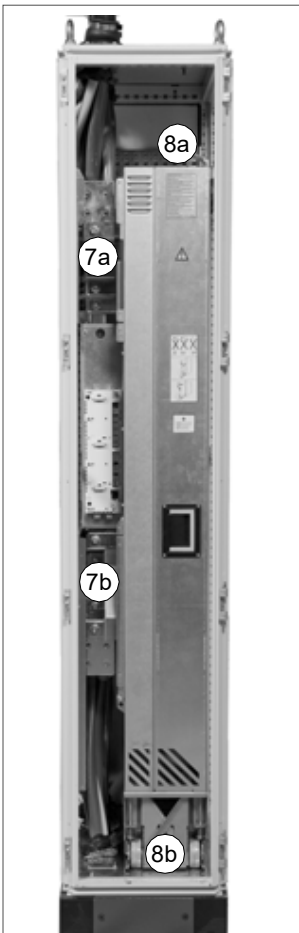
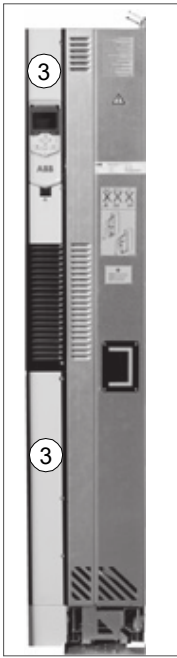
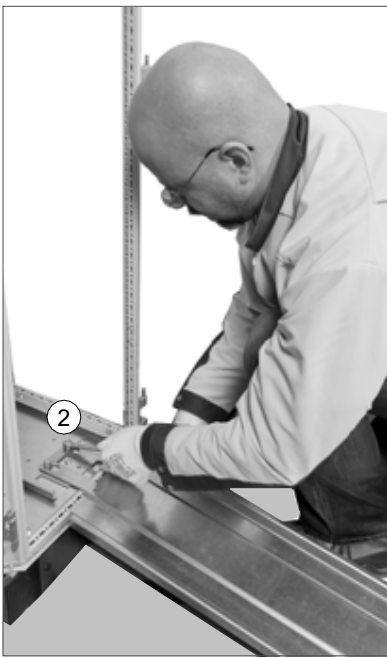

Assembly drawing of installing the drive module to the enclosure (frame R10)

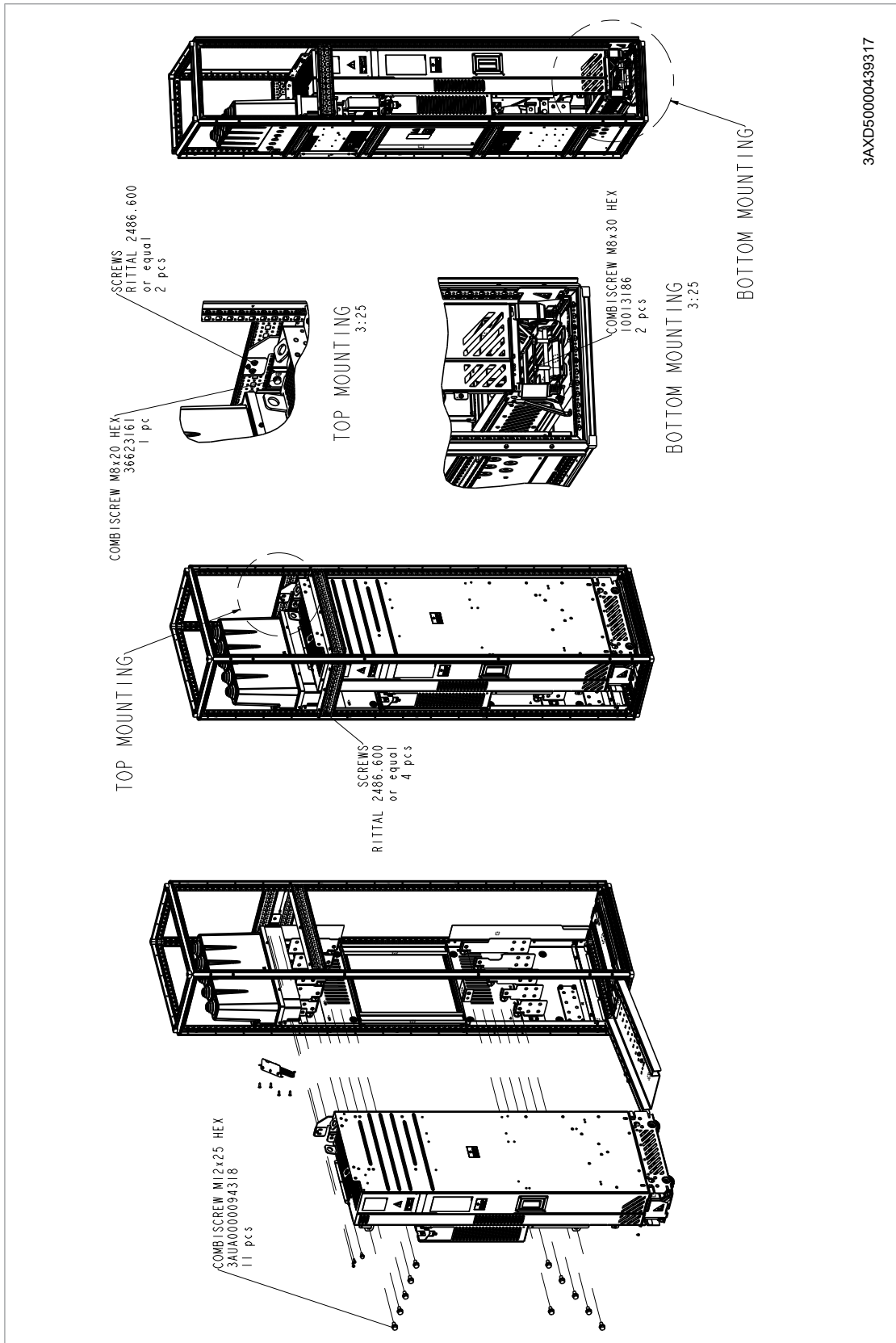

Assembly drawing of installing the drive module to the enclosure (frame R11)

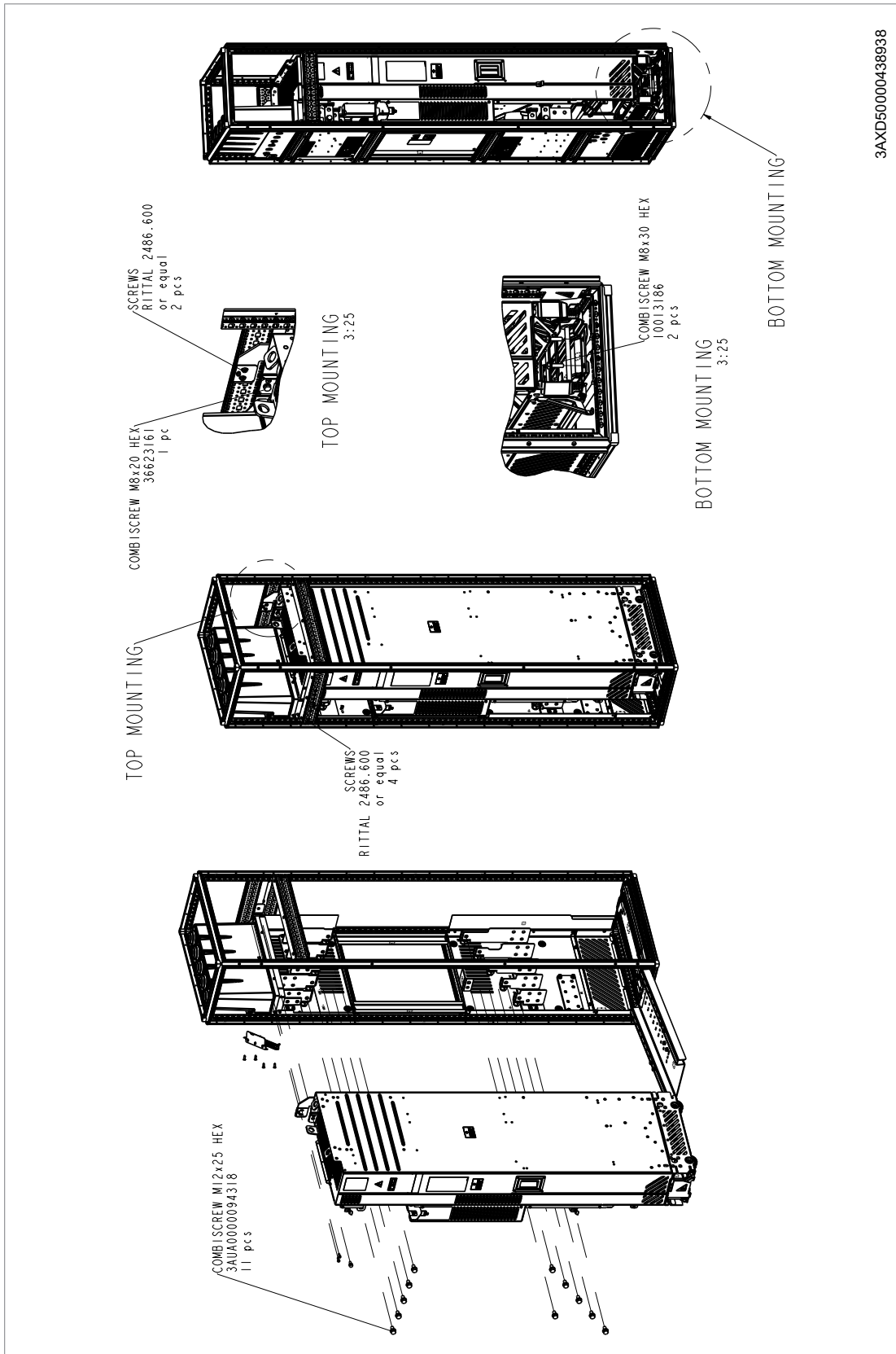

Assembly drawing of installing the roof and door

This drawing shows a layout tested by ABB. If you use ABB air filters, install them vertically in the positions shown in section [Installing the roof and door \(ABB air filters and roof\)](#) (page 136).

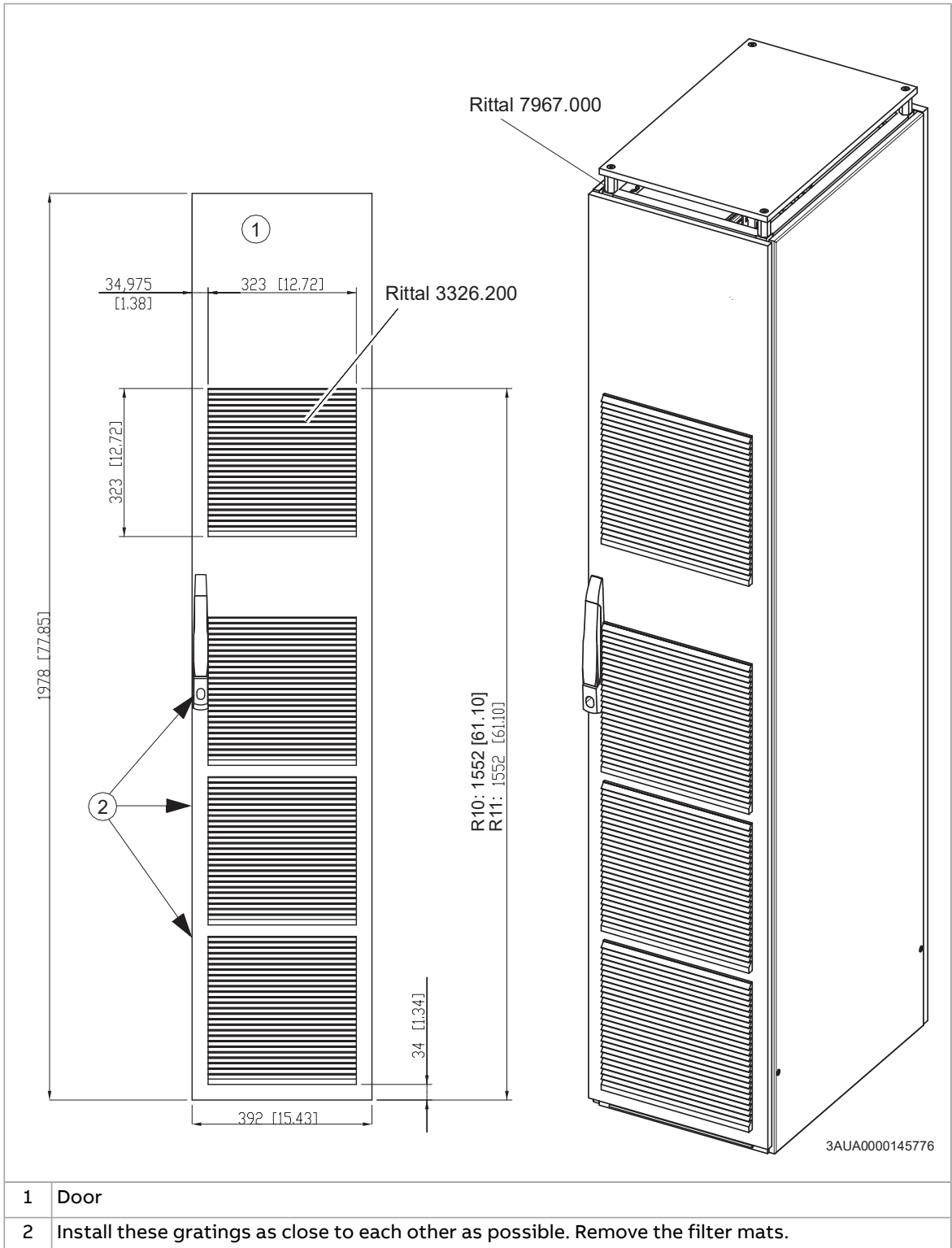

■ Removing the protective covering from the drive module air outlet



▲WARNING Remove the protective cover from the top of the module after the module is installed. The protective cover prevents cooling airflow and can cause the module to overheat.



Miscellaneous

■ Installations with input and motor cables of size $4 \times 240 \text{ mm}^2$ per phase

If resistor cables are to be connected, the lower side plate of the output cabling panel must be removed and the resistor cables lead from side to the terminals of the output cabling panel.

■ Installing the rubber grommet

To get IP20 degree of protection for the drive module, install the input power cables through the rubber grommet. Install the grommet as follows:

1. Cut adequate holes into the grommet for the input power cables.
2. Put the cables through the grommet.
3. Attach the grommet to the input cabling panel with five M4×8 Torx T20 screws as shown below.

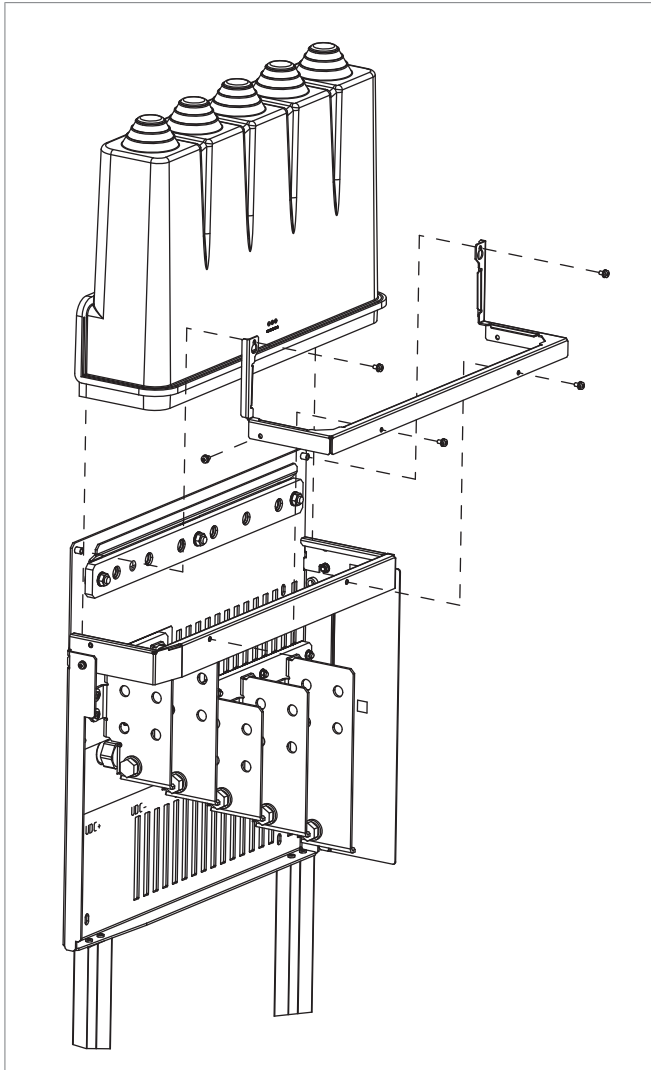

11

Installation checklist

Contents of this chapter

This chapter contains a checklist for the mechanical and electrical installation of the drive.

Checklist



▲WARNING Obey the safety instructions of the drive. If you ignore them, injury or death, or damage to the equipment can occur. If you are not a qualified electrical professional, do not do electrical installation, commissioning or maintenance work.



▲WARNING Do the steps in section [Electrical safety precautions \(page 18\)](#) before you start the work.

Examine the mechanical and electrical installation of the drive before start-up. Do the tasks in the checklist together with a second person.

Make sure that ...	<input checked="" type="checkbox"/>
The ambient operating conditions meet the drive ambient conditions specification and enclosure rating (IP code).	<input type="checkbox"/>
The supply voltage matches the nominal input voltage of the drive. Refer to the type designation label.	<input type="checkbox"/>
The insulation resistance of the input power cable, motor cable and motor is measured according to local regulations and the manuals of the drive.	<input type="checkbox"/>
The drive cabinet is attached to the floor, and if necessary due to vibration etc, also by its top to the wall or roof.	<input type="checkbox"/>
The drive module is fastened properly to the enclosure.	<input type="checkbox"/>

156 Installation checklist

Make sure that ...	<input checked="" type="checkbox"/>
The cooling air can flow freely in and out of the drive. Air recirculation inside the cabinet is not possible (air baffle plates are installed, or there is another air guiding solution).	<input type="checkbox"/>
<u>If the drive is connected to a network other than a symmetrically grounded TN-S system:</u> You have done all the required modifications (for example, you may need to disconnect the EMC filter or ground-to-phase varistor). Refer to the electrical installation instructions.	<input type="checkbox"/>
The enclosures of the equipment in the cabinet have proper galvanic connection to the cabinet protective earth (ground) busbar; The connection surfaces at the fastening points are bare (unpainted) and the connections are tight, or separate grounding conductors have been installed.	<input type="checkbox"/>
The main circuit connections inside the drive cabinet correspond to the circuit diagrams.	<input type="checkbox"/>
The control unit has been connected. Refer to the circuit diagrams.	<input type="checkbox"/>
Appropriate AC fuses and main disconnecting device are installed.	<input type="checkbox"/>
There is an adequately sized protective earth (ground) conductor(s) between the drive and the switchboard, the conductor is connected to correct terminal, and the terminal is tightened to the correct torque. Grounding has also been measured according to the regulations.	<input type="checkbox"/>
The input power cable is connected to the correct terminals, the phase order is correct, and the terminals are tightened to the correct torque.	<input type="checkbox"/>
There is an adequately sized protective earth (ground) conductor between the motor and the drive. The conductor is connected to the correct terminal, and the terminal is tightened to the correct torque. Grounding has also been measured according to the regulations.	<input type="checkbox"/>
The motor cable is connected to the correct terminals, the phase order is correct, and the terminals are tightened to the correct torque.	<input type="checkbox"/>
The motor cable is routed away from other cables.	<input type="checkbox"/>
No power factor compensation capacitors are connected to the motor cable.	<input type="checkbox"/>
<u>If an external brake resistor is connected to the drive:</u> There is an adequately sized protective earth (ground) conductor between the brake resistor and the drive, and the conductor is connected to the correct terminal, and the terminals are tightened to the correct torque. Grounding has also been measured according to the regulations.	<input type="checkbox"/>
<u>If an external brake resistor is connected to the drive:</u> The brake resistor cable is connected to the correct terminals, and the terminals are tightened to the correct torque.	<input type="checkbox"/>
<u>If an external brake resistor is connected to the drive:</u> The brake resistor cable is routed away from other cables.	<input type="checkbox"/>
The control cables are connected to the correct terminals, and the terminals are tightened to the correct torque.	<input type="checkbox"/>
<u>If a drive bypass connection will be used:</u> The direct-on-line contactor of the motor and the drive output contactor are either mechanically and/or electrically interlocked, that is, they cannot be closed at the same time. A thermal overload device must be used for protection when bypassing the drive. Refer to local codes and regulations.	<input type="checkbox"/>
There are no tools, foreign objects or dust from drilling inside the drive.	<input type="checkbox"/>
The area in front of the drive is clean: the drive cooling fan cannot draw any dust or dirt inside.	<input type="checkbox"/>
The terminal box cover of the motor is in place. Cabinet shrouds are in place and doors are closed.	<input type="checkbox"/>
The motor and the driven equipment are ready for power-up.	<input type="checkbox"/>

12

Start-up

Contents of this chapter

This chapter describes the start-up procedure of the drive.

Reforming the capacitors

The capacitors must be reformed if the drive has not been powered (either in storage or unused) for a year or more. The manufacturing date is on the type designation label. For information on reforming the capacitors, refer to [Capacitor reforming instructions \(3BFE64059629 \[English\]\)](#).

Start-up procedure

1. Only qualified electrical professionals are allowed to start-up the drive.
2. Make sure that the installation of the drive module has been checked according to the checklist in chapter Installation checklist, and that the motor and driven equipment are ready for start.
3. Perform the start-up tasks instructed by the cabinet-installer of the drive module.
4. Switch the power on, setup the drive control program, and perform the first start of the drive and motor. See [Quick start-up guide for ACS880 drives with primary control program \(3AUA0000098062 \[English\]\)](#) or [ACS880 primary control program firmware manual \(3AUA0000085967 \[English\]\)](#). If you need more information on the use of the control panel, see [ACS-AP-I, -S, -W and ACH-AP-H, -W Assistant control panels user's manual \(3AUA0000085685 \[English\]\)](#).



- For drives with resistor braking (option +D150): See also section Start-up in chapter Resistor braking.
 - For drives with ABB du/dt filter: Make sure that bit 13 of parameter 95.20 HW options word 1 is switched on.
 - For drives with ABB sine filter: Make sure that parameter 95.15 Special HW settings is set to ABB sine filter. For other sine filters: See [Sine filter hardware manual \(3AXD50000016814 \[English\]\)](#).
5. For drives with ABB motors in explosive atmospheres: See also [ACS880 drives with ABB motors in explosive atmospheres \(3AXD50000019585 \[English\]\)](#).
 6. For drive modules in which the Safe torque off function is in use: Test and validate the operation of the Safe torque off function. See [Validation test procedure \(page 241\)](#).
 7. For drive modules with an FSO-xx safety functions module (options +Q972 and Q973): Test and validate the operation of the safety functions. See the delivery-specific circuit diagrams and [FSO-12 safety functions module user's manual \(3AXD50000015612 \[English\]\)](#) or [FSO-21 safety functions module user's manual \(3AXD50000015614 \[English\]\)](#).



13

Fault tracing

Contents of this chapter

This chapter describes the fault tracing possibilities of the drive.

LEDs

The table below describes the LEDs of the drive module with option +J410.

Where	LED	Color	When the LED is lit
Control panel mounting platform	POWER	Green	Control unit is powered and +15 V is supplied to the control panel
	FAULT	Red	Drive in fault state

Warning and fault messages

See the quick installation and start-up guide or the firmware manual for the descriptions, causes and remedies of the control program warning and fault messages.

14

Maintenance

Contents of this chapter

This chapter contains maintenance instructions of the drive modules.

Maintenance intervals

The tables show the maintenance tasks that can be done by the end user. For the ABB Service offering, contact your local ABB Service representative (new.abb.com/contact-centers).

■ Description of symbols

Action	Description
I	Inspection (visual inspection and maintenance action if needed)
P	Performance of on/off-site work (commissioning, tests, measurements or other work)
R	Replacement

■ Recommended maintenance intervals after start-up

Recommended annual actions by the user	
Action	Description
P	Quality of supply voltage
I	Spare parts
P	DC circuit capacitors reforming, spare modules and spare capacitors
I	Tightness of terminals
I	Dustiness, corrosion and temperature
I	Heat sink cleaning

Component	Years from start-up						
	3	6	9	12	15	18	21
Cooling							
Main cooling fan							
Main cooling fan (R10 and R11)			R			R	
Auxiliary cooling fan							
Circuit board compartment cooling fans (R10 and R11) LONG-LIFE			R			R	
Aging							
ZCU control unit battery (real-time clock)		R		R		R	
Control panel battery (real-time clock)			R			R	
Functional safety							
Safety function test	I See the maintenance information of the safety function.						
Safety component expiry (Mission time, T_M)	20 years						
4FPS10000239703							

Note:

- The maintenance and component replacement intervals are based on the assumption that the equipment operates within the specified ratings and ambient conditions. ABB recommends annual drive inspections to ensure the highest reliability and optimum performance.
- Long-term operation near the specified maximum ratings or ambient conditions may require shorter maintenance intervals for certain components. Contact your local ABB Service representative for additional maintenance recommendations.

Cabinet

■ Cleaning the interior of the cabinet



▲WARNING Obey the safety instructions of the drive. If you ignore them, injury or death, or damage to the equipment can occur. If you are not a qualified electrical professional, do not do electrical installation, commissioning or maintenance work.

NOTICE Use an antistatic wrist strap and a vacuum cleaner with an antistatic hose and nozzle. A normal vacuum cleaner creates static discharges which can cause damage to circuit boards.

1. Stop the drive and do the steps in section [Electrical safety precautions \(page 18\)](#) before you start the work.
2. Open the cabinet door.
3. Clean the interior of the cabinet. Use a vacuum cleaner and a soft brush.
4. Clean the air inlets of the fans and air outlets of the modules (top).
5. Clean the air inlet gratings (if any) on the door.
6. Close the door.

Heatsink

The drive module heatsink collects dust from the cooling air. If the heatsink is not clean, the drive can generate overtemperature warnings and faults. When necessary, clean the heatsink as described in this section.

■ Cleaning the interior of the heatsink



▲WARNING Obey the safety instructions of the drive. If you ignore them, injury or death, or damage to the equipment can occur.

NOTICE Use an antistatic wrist strap and a vacuum cleaner with an antistatic hose and nozzle. A normal vacuum cleaner creates static discharges which can cause damage to circuit boards.

1. Stop the drive and do the steps in section [Electrical safety precautions \(page 18\)](#) before you start the work.
 2. Remove the attaching screws of the handle plate of the drive module.
 3. Remove the handle plate.
 4. Vacuum the interior of the heatsink from the opening.
 5. Carefully blow clean compressed air (not humid or oily) upwards from the opening and, at the same time, vacuum from the top of the drive module. Prevent dust from entering adjoining equipment.
 6. Reinstall the handle plate.
-

164 Maintenance

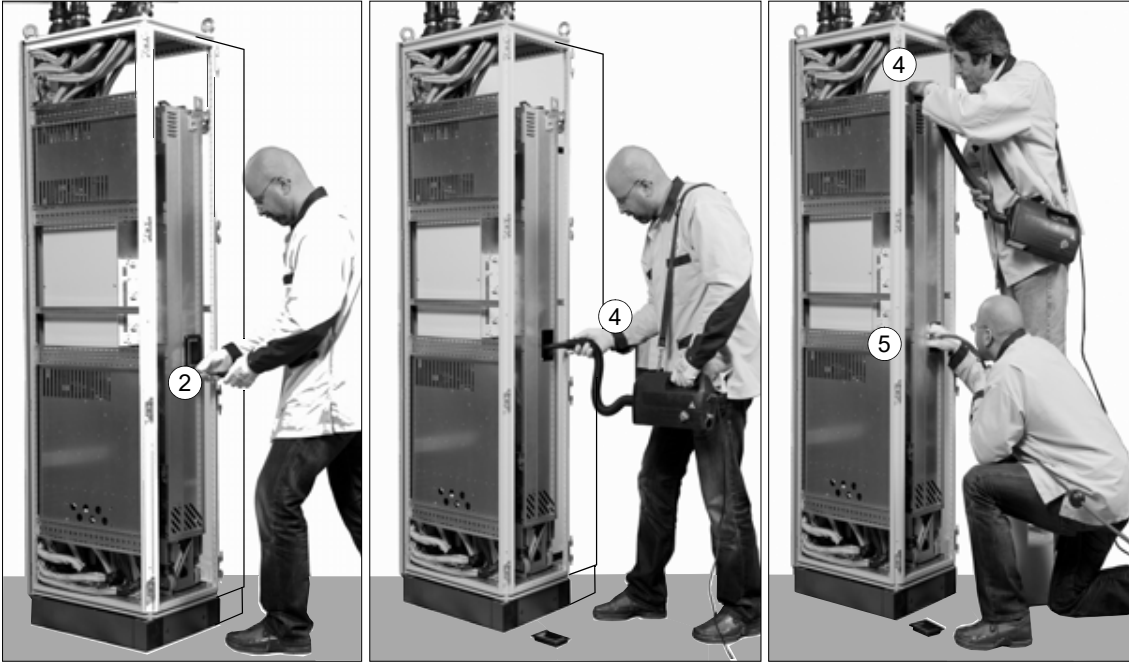

Fans

The lifespan of the cooling fans of the drive depends on running time, ambient temperature and dust concentration. Refer to the firmware manual for the actual signal which indicates the running time of the cooling fan. Reset the running time signal after fan replacement.

Replacement fans are available from ABB. Do not use other than ABB-specified spare parts.

■ Replacing the circuit board compartment cooling fans



▲WARNING Obey the safety instructions of the drive. If you ignore them, injury or death, or damage to the equipment can occur.

1. Stop the drive and do the steps in section [Electrical safety precautions \(page 18\)](#) before you start the work.
2. Remove the drive module out of the cabinet as described in module replacement instructions.
3. Undo the fastening screw of the fan enclosure.
4. Unplug the power supply cable of the fan.
5. Install the new fan in reverse order to the above.
6. Reset the counter (if used) in group 5 in the control program.

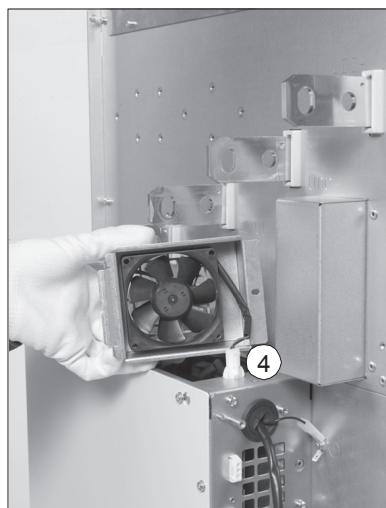

■ Replacing the main cooling fans



▲WARNING Obey the safety instructions of the drive. If you ignore them, injury or death, or damage to the equipment can occur.

1. Stop the drive and do the steps in section [Electrical safety precautions \(page 18\)](#) before you start the work.
2. Remove the drive module out of the cabinet as described in module replacement instructions.
3. Open the support legs of the pedestal.
4. Remove the two screws that fasten the fan assembly plate.
5. Tilt the fan assembly plate down.
6. Disconnect the power supply wires of the fans.
7. Remove the fan assembly from the drive module.
8. Remove the fastening screws of the fan(s) and remove the fan(s) from the assembly plate.
9. Install the new fan(s) in reverse order to the above.
10. Reset the counter (if used) in parameter group 5 in the control program.

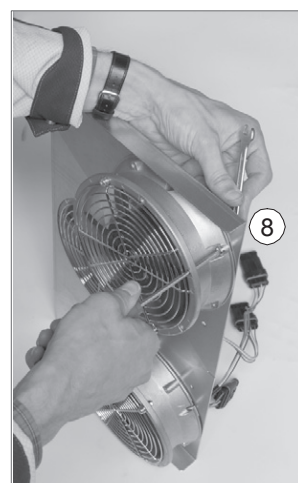
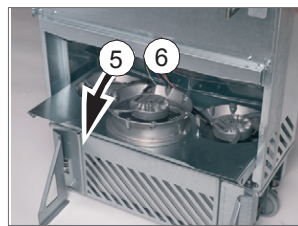

Replacing the standard drive module



⚠ WARNING Obey the safety instructions of the drive. If you ignore them, injury or death, or damage to the equipment can occur.

Note: The replacement module must be of the same type as the original module: same type code and same option codes.

Handle the drive module carefully:

- Use safety shoes with a metal toe cap to prevent foot injury.
- Lift the drive module only by the lifting lugs.
- Make sure that the module does not topple over when you move it on the floor: To open the support legs, press each leg a little down and turn it aside (1, 2). Whenever possible secure the module also with chains.
- Do not tilt the drive module. It is heavy and its center of gravity is high. The module overturns from a sideways tilt of 5 degrees. Do not leave the module unattended on a sloping floor.

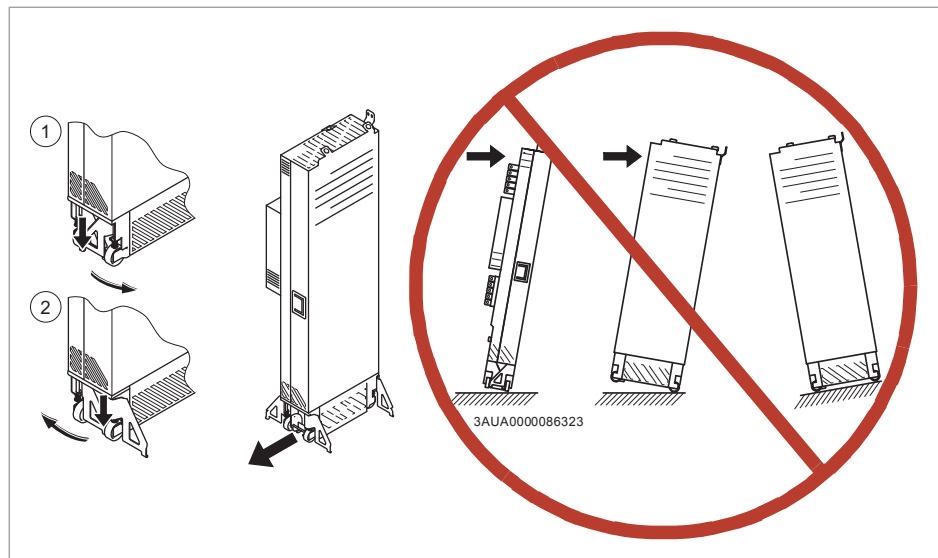

1. Stop the drive and do the steps in section [Electrical safety precautions \(page 18\)](#) before you start the work.
2. Remove the clear plastic shrouds on the power cables and parts in front of the drive module (if present).
3. Disconnect the power cables.
4. Disconnect the power supply, BGDR and fiber optic cables from the drive module.
5. Disconnect the power supply cable and the fiber optic cables from the external control unit and coil them on the top of the drive module.
6. Remove the screws that attach the drive module to the cabinet at the top and behind the front support legs.
7. Attach the extraction ramp to the cabinet base with two screws.
8. To prevent the drive module from falling, attach its top lifting lugs with chains to the cabinet frame.

168 Maintenance

9. Pull the drive module carefully out of the cabinet preferably with help from another person.
10. Install the new module in reverse order.

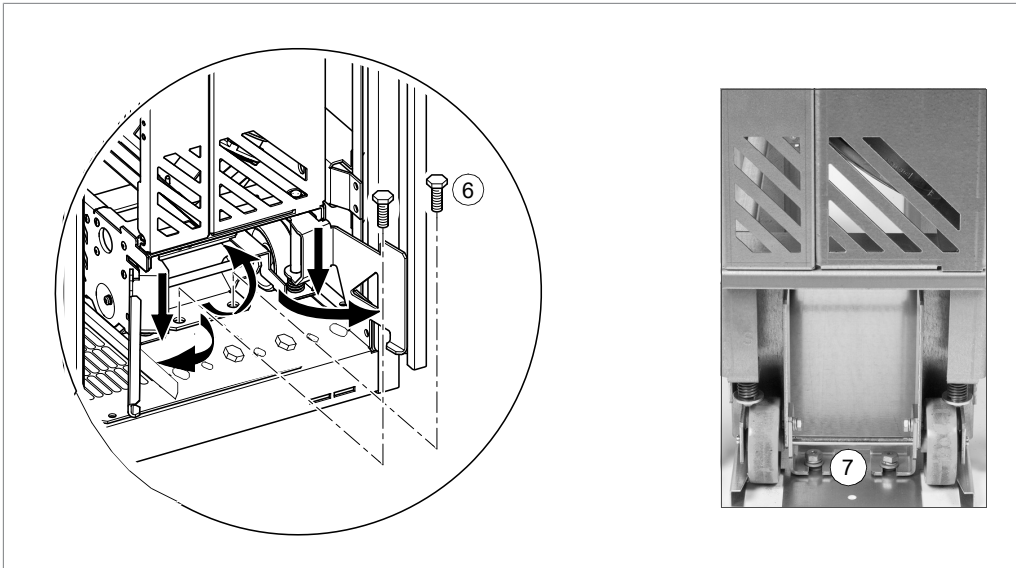

Replacing the drive module with option +H381



⚠WARNING Obey the safety instructions of the drive. If you ignore them, injury or death, or damage to the equipment can occur.

Note: The replacement module must be of the same type as the original module: same type code and same option codes.

Handle the drive module carefully:

- Use safety shoes with a metal toe cap to prevent foot injury.
- Lift the drive module only by the lifting lugs.
- Make sure that the module does not topple over when you move it on the floor: To open the support legs, press each leg a little down and turn it aside (1, 2). When possible, secure the module also with chains.
- Do not tilt the drive module. It is heavy and its center of gravity is high. The module overturns from a sideways tilt of 5 degrees. Do not leave the module unattended on a sloping floor.

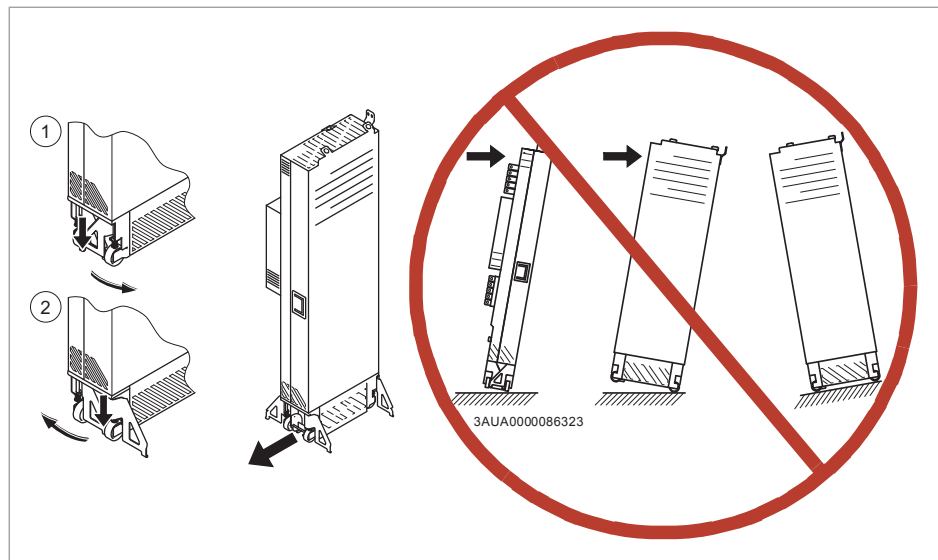

1. Stop the drive and do the steps in section [Electrical safety precautions \(page 18\)](#) before you start the work.
2. Undo the fastening screws to remove the left-hand side upper and lower front covers of the drive module. M4×10 combi screws, 2 N·m (18 lbf·in).
For drive modules with an integrated control unit (option +P905) and control panel (option +J414): Remove the control panel and the control panel cable from the integrated control unit.
3. Disconnect the drive module busbars from the input cabling panel. Combi screw M12, 70 N·m (52 lbf·ft).
4. Disconnect the drive module busbars from the output cabling panel. Combi screw M12, 70 N·m (52 lbf·ft).
5. Undo the screws that attach the drive module to the cabinet at the top (a) and behind the front support legs (b).
6. Remove the front air baffle.

7. Attach the extraction/installation ramp to the cabinet base with two screws.
 8. Disconnect the power supply cables, STO cables and the fiber optic cables from the external control unit and wind them on the top of the drive module.
For drive modules with an integrated control unit (option +P905): Detach the control unit from the drive module by undoing the fastening screws below the optional modules and turn the control unit and the cables aside. (Alternatively remove the clamp plate, and disconnect the cables from the control unit.)
 9. To prevent the drive module from falling, attach its top lifting lugs with chains to the cabinet frame.
 10. Pull the drive module carefully out of the cabinet, preferably with help from another person.
 11. Install the new module in reverse order to the above.
-

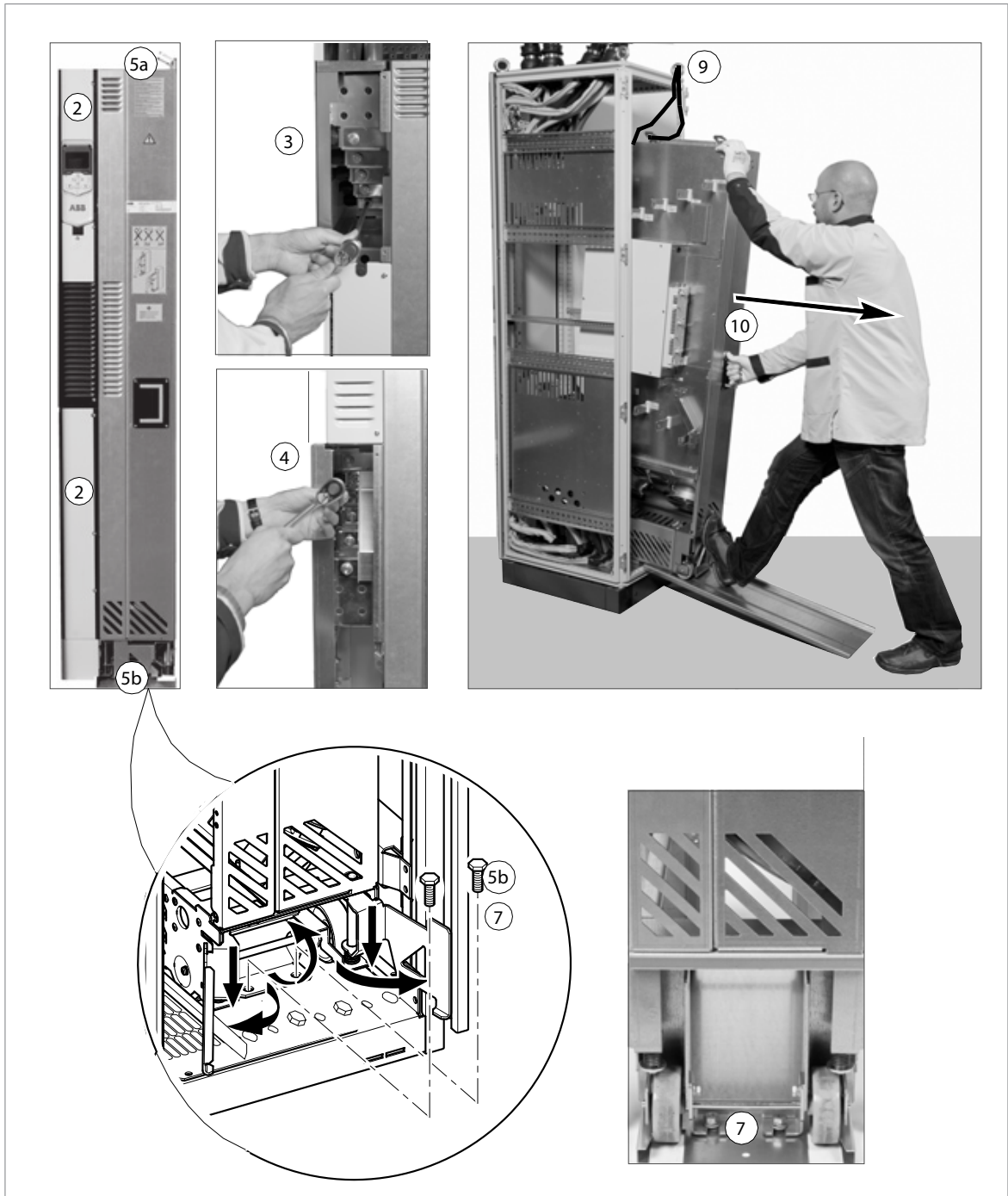

Capacitors

The intermediate DC circuit of the drive contains several electrolytic capacitors. Operating time, load, and surrounding air temperature have an effect on the life of the capacitors. Capacitor life can be extended by decreasing the surrounding air temperature.

Capacitor failure is usually followed by damage to the unit and an input cable fuse failure, or a fault trip. If you think that any capacitors in the drive have failed, contact ABB.

■ Reforming the capacitors

The capacitors must be reformed if the drive has not been powered (either in storage or unused) for a year or more. The manufacturing date is on the type designation label. For information on reforming the capacitors, refer to [Capacitor reforming instructions \(3BFE64059629 \[English\]\)](#).

Control panel

See [ACS-AP-I, -S, -W and ACH-AP-H, -W assistant control panels user's manual \(3AUA0000085685 \[English\]\)](#).

Control unit

For maintenance information of the UCU-20 control unit (option +V998), refer to [UCU-20 control unit hardware manual \(3AXD50001079246 \[English\]\)](#).

■ Replacing the ZCU-14 control unit battery



▲WARNING Obey the safety instructions of the drive. If you ignore them, injury or death, or damage to the equipment can occur. If you are not a qualified electrical professional, do not do electrical installation, commissioning or maintenance work.

1. Stop the drive and do the steps in section [Electrical safety precautions \(page 18\)](#) before you start the work.
 2. Remove the M4×8 (T20) screws at the ends of the control unit.
 3. To see the battery, remove the XD2D terminal block.
 4. Carefully lift the edge of the control unit cover on the side with the I/O terminal blocks.
 5. Pull the battery out of the battery holder.
 6. Put a new CR2032 battery into the battery holder.
 7. Close the control unit cover.
 8. Tighten the M4×8 (T20) screws.
 9. Install the XD2D terminal block.
-

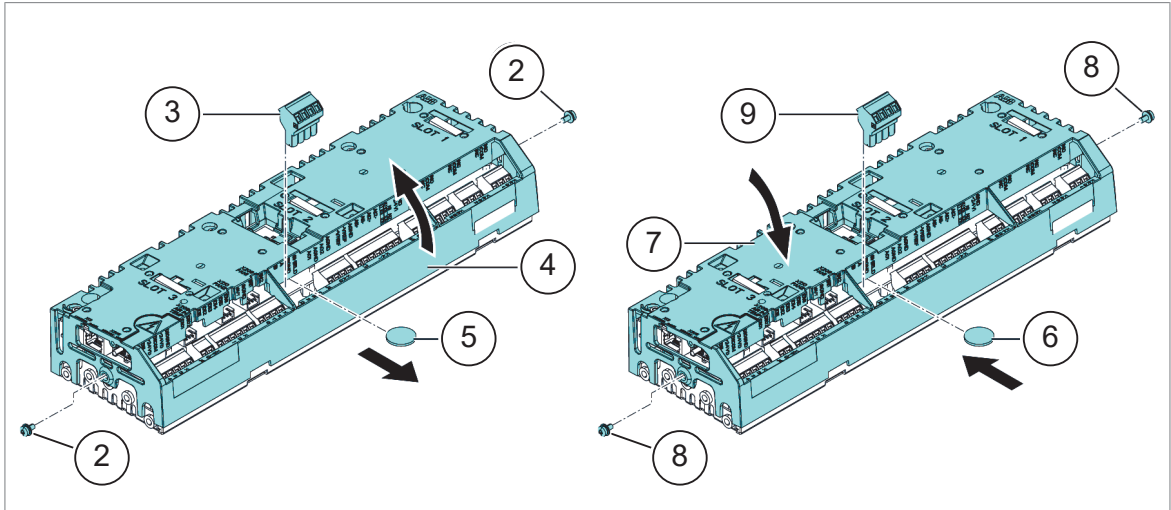

■ Replacing the memory unit of ZCU-14



▲WARNING Obey the safety instructions of the drive. If you ignore them, injury or death, or damage to the equipment can occur. If you are not a qualified electrical professional, do not do electrical installation, commissioning or maintenance work.



▲WARNING Do not remove or install the memory unit when the control unit is energized. There can be a risk of electric shock from relay outputs or adjacent equipment. Also, damage to the control unit or memory unit can occur.

After replacing a control unit, you can keep the existing parameter settings by transferring the memory unit from the defective control unit to the new control unit. After power-up, the control unit will scan the memory unit. This can take several minutes.

1. Stop the drive and do the steps in section [Electrical safety precautions \(page 18\)](#) before you start the work.
2. Pull the clip of the memory unit forward.

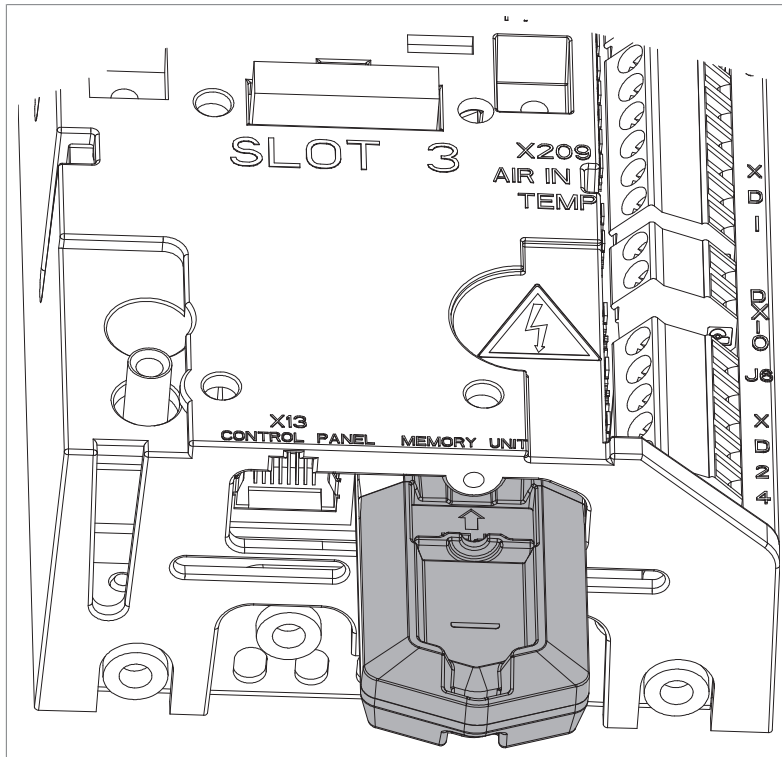

3. Remove the memory unit.
4. Install a new memory unit in reverse order.

Replacing safety functions modules FSO-12 (option +Q973) and FSO-21 (option +Q972)

Do not repair safety functions modules. Replace a faulty module with a new one as described in section [Installing the FSO-xx safety functions module \(page 118\)](#).

Functional safety components

The mission time of functional safety components is 20 years which equals the time during which failure rates of electronic components remain constant. This applies to the components of the standard Safe torque off circuit as well as any modules, relays and, typically, any other components that are part of functional safety circuits.

The expiry of mission time terminates the certification and SIL/PL classification of the safety function. The following options exist:

- Renewal of the whole drive and all optional functional safety module(s) and components.
- Renewal of the components in the safety function circuit. In practice, this is economical only with larger drives that have replaceable circuit boards and other components such as relays.

Note that some of the components may already have been renewed earlier, restarting their mission time. The remaining mission time of the whole circuit is however determined by its oldest component.

For more information, contact ABB.

15

Ordering information

Contents of this chapter

This chapter gives ordering information on additional components available from ABB for the drive module installation.

Note: This chapter only lists the installation accessories available from ABB. All other parts must be sourced from a third party by the system integrator.

See the installation examples for Rittal VX25 enclosure tested by ABB in sections [Installing the roof and door \(Rittal parts\) \(page 135\)](#) and [Assembly drawing of installing the roof and door \(page 151\)](#), or dimension your own cabinet.

Control panel

ACS-AP-W control panel is included with the drive module. A control panel is required for the commissioning of an ACS880 drive system, even if the Drive composer PC tool is used.

The control panel can be mounted on the cabinet door with the help of a door mounting kit.

Type	Description	Ordering code	Illustration
ACS-AP-W	Control panel with Bluetooth	3AXD50000025965	

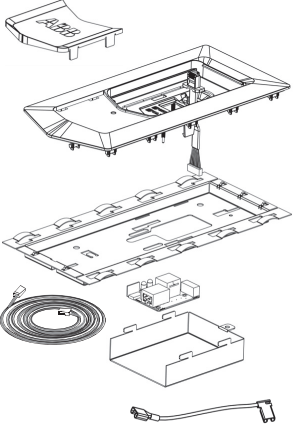
Type	Description	Ordering code	Illustration
ACS-AP-I	Control panel	3AUA0000088311	
DPMP-01	Door mounting kit for flush mounting. Includes a control panel mounting platform, an IP54 cover and a 3-meter panel connection cable.	3AUA0000108878	

Brake choppers and resistors

See chapter [Resistor braking \(page 251\)](#).

Output (du/dt) filters

See section [\$du/dt\$ filters \(page 259\)](#).

Sine filters

See section [Sine filters \(page 260\)](#).

EMC filter ARFI-10

Ordering code: 68241561

Cabinet ventilation

■ Air inlet kits

Mounting screws are included.

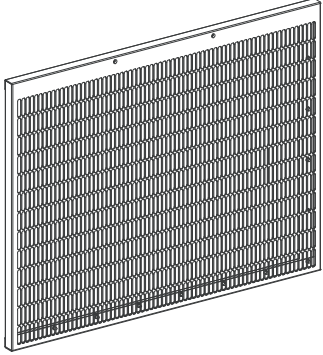
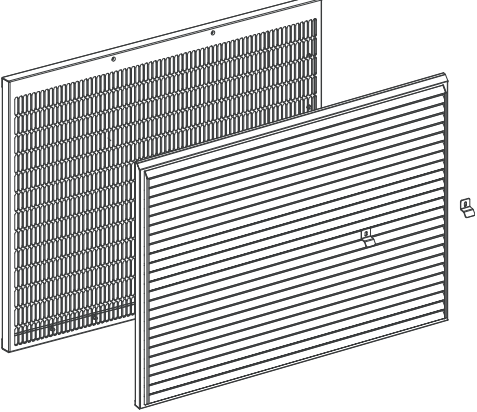
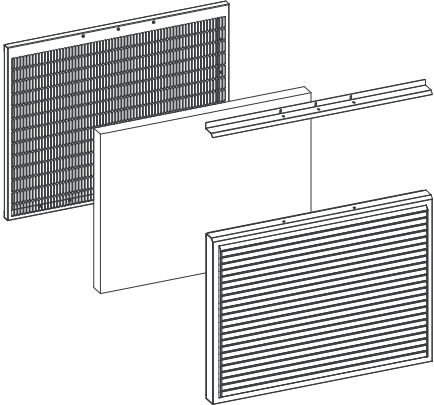
Enclosure width / Degree of protection	Kit code	Ordering code	Illustration
800 mm / IP20	A-8-X-023	3AUA0000117005	 <p data-bbox="987 696 1390 725">Instruction code: 3AUA0000116887</p>
800 mm / IP42	A-8-X-026	3AUA0000117009	 <p data-bbox="987 1189 1390 1218">Instruction code: 3AUA0000116875</p>
800 mm / IP54	A-8-X-029	3AXD50000009186	 <p data-bbox="978 1675 1398 1704">Instruction code: 3AXD50000010001</p>

■ Air outlet kits

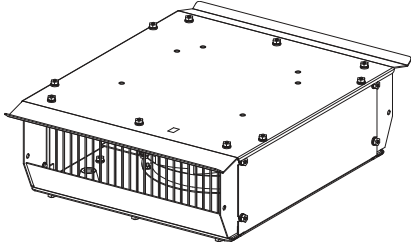
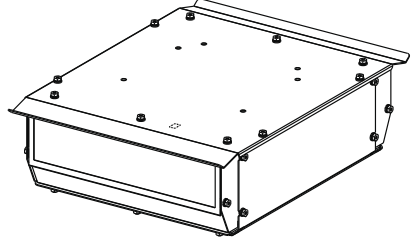
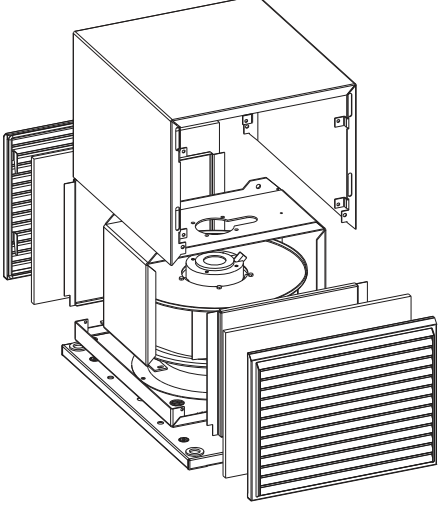
Enclosure width / Degree of protection	Qty	Kit code	Ordering code	Illustration
800 mm / IP20	2	A-4-X-062	3AUA0000125201	 <p data-bbox="858 651 1270 678">Instruction code: 3AXD50000001982</p> <p data-bbox="868 696 1260 723">Note: Fan to be ordered separately</p>
800 mm / IP42	2	A-4-X-060	3AUA0000114967	 <p data-bbox="858 1016 1270 1043">Instruction code: 3AUA0000115290</p> <p data-bbox="868 1061 1260 1088">Note: Fan to be ordered separately</p>
800 mm / IP54 (IEC)	2	A-4-X-064	3AXD50000009187	 <p data-bbox="858 1641 1270 1668">Instruction code: 3AXD50000010284</p> <p data-bbox="868 1686 1260 1713">Note: Fan to be ordered separately</p>

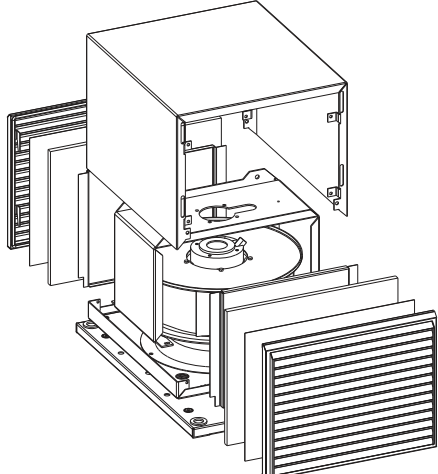
Enclosure width / Degree of protection	Qty	Kit code	Ordering code	Illustration
800 mm / IP54 (UL)	2	A-4-X-067	3AXD50000010362	 <p>Instruction code: 3AXD50000010284</p> <p>Note: Fan to be ordered separately</p>

Cooling fans

Two cooling fans must be installed inside the air outlet compartment of each drive module to ensure sufficient cooling of the cabinet.

UL				
Enclosure width / Degree of protection (Auxiliary voltage)	Component		Qty	Ordering code
	Name	Data		
800 mm / IP20, IP42 (230 V 50/60 Hz)	Fan	0.77 A; 230 V; 96 W; 50/60 Hz	2	3AXD50000000592
	Connector	PLUG; 12 AWG; 2.50 mm ²	2	3AXD50000000723
	Connector	SOCKET; 12 AWG; 2.50 mm ²	2	3AXD50000000724
800 mm / IP20, IP42 (115 V 60 Hz)	Fan	115 V; 115 W; 50/60 Hz	2	3AXD50000700288
	Connector	PLUG; 12 AWG; 2.50 mm ²	2	3AXD50000000723
	Connector	SOCKET; 12 AWG; 2.50 mm ²	2	3AXD50000000724
800 mm / IP54 (230 V 50/60 Hz)	Fan	1.1 A; 230 V; 240 W; 50 Hz 1.45 A; 230 V; 350 W; 60 Hz	2	3AXD50000006934
	Capacitor	6 µF, 600 V	2	3AXD50000006959
	Connector	PLUG; 12 AWG; 2.50 mm ²	2	3AXD50000000723
	Connector	SOCKET; 12 AWG; 2.50 mm ²	2	3AXD50000000724
800 mm / IP54 (115 V 50/60 Hz)	Fan	3.1 A; 115 V; 300 W; 50 Hz 3.9 A; 115 V; 430 W; 60 Hz	2	64750062
	Capacitor	25 µF, 220 V	2	68713188
	Connector	PLUG; 12 AWG; 2.50 mm ²	2	3AXD50000000723
	Connector	SOCKET; 12 AWG; 2.50 mm ²	2	3AXD50000000724

FSO accessories kit

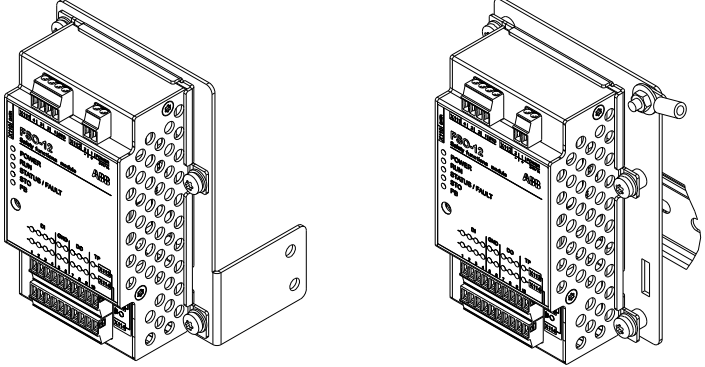
Kit code	Ordering code	Illustration
A-X-X-279	3AXD50000025495	 <p>Instruction code: 3AXD50000025583</p>

Control panel mounting platforms

Kit	Ordering code
DPMP-02 control panel mounting platform	3AXD50000009374
DPMP-04 control panel mounting platform	3AXD50000217717

Retrofit accessory kits

Kit	Option code	Ordering code
Common mode filter kit	+E208	3AXD50000026145
Full size cable connection terminals for input power cables	+H370	3AXD50000019542
Full size cable connection terminals for output power cables	1)	3AXD50000019544
For frame R10: Full power cabling panels to be attached to a cabinet (IP20)	H381	3AXD50000019546
For frame R11: Full power cabling panels to be attached to a cabinet (IP20)	H381	3AXD50000019533
Power cable connection terminals on the right-hand side of the drive module	H391	3AXD50000025765
Flat mounting	C173	3AXD50000019535
For frame R10: IP20 shrouds for covering the input and motor cabling area	2)	3AXD50000019537
For frame R11: IP20 shrouds for covering the input and motor cabling area	2)	3AXD50000019538

¹⁾ The drive module is delivered with full size cable connection terminals for output power cables as standard. They can be excluded with option +0H371.

²⁾ The drive module is delivered with IP20 shrouds for covering the input and motor cabling area as standard. The shrouds can be excluded with option +0B051.

16

Technical data

Contents of this chapter

This chapter contains the technical specifications of the drive, for example the ratings, sizes and technical requirements, provisions for fulfilling the requirements for CE and other markings.

Marine type-approved drives (option +C132)

See [ACS880-01/04 +C132 marine type-approved drives supplement \(3AXD50000010521 \[English\]\)](#) for the ratings, marine-specific data and reference to valid marine type approvals.

Electrical ratings

The ratings of the drive module packages with 50 Hz and 60 Hz supply are given below.

IEC RATINGS											
ACS880-04...	Frame size	Input current	Output ratings								
			Nominal use					Light-duty use		Heavy-duty use	
			I_1	I_{max}	I_{max_start}	I_2	P_n	S_n	I_{Ld}	P_{Ld}	I_{Hd}
A	A	A	A	kW	kVA	A	kW	A	kW		
$U_n = 400\text{ V}$											
505A-3	R10	505	560	671	505	250	350	485	250	361	200
585A-3	R10	585	730	828	585	315	405	575	315	429	250
650A-3	R10	650	730	954	650	355	450	634	355	477	250
725A-3	R11	725	1020	1100	725	400	502	715	400	566	315
820A-3	R11	820	1020	1100	820	450	568	810	450	625	355
880A-3	R11	880	1100	1100	880	500	610	865	500	725*	400

IEC RATINGS												
ACS880-04...	Frame size	Input current	Output ratings									
			Nominal use					Light-duty use		Heavy-duty use		
			I_1	I_{max}	I_{max_start}	I_2	P_n	S_n	I_{Ld}	P_{Ld}	I_{Hd}	P_{Hd}
			A	A	A	A	kW	kVA	A	kW	A	kW
$U_n = 500\text{ V}$												
460A-5	R10	460	560	671	460	315	398	450	315	330	200	
503A-5	R10	505	560	671	503	355	436	483	315	361	250	
583A-5	R10	585	730	828	583	400	505	573	400	414	250	
635A-5	R10	650	730	954	635	450	550	623	450	477	315	
715A-5	R11	725	850	1100	715	500	619	705	500	566	400	
820A-5	R11	820	1020	1100	820	560	710	807	560	625	450	
880A-5	R11	880	1100	1100	880	630	762	857	560	697**	500	
$U_n = 690\text{ V}$												
330A-7	R10	330	480	510	330	315	394	320	315	255	250	
370A-7	R10	370	520	650	370	355	442	360	355	325	315	
430A-7	R10	430	540	720	430	400	514	420	400	360***	355	
470A-7	R11	470	655	830	470	450	562	455	450	415	400	
522A-7	R11	522	685	910	522	500	624	505	500	455	450	
590A-7	R11	590	800	1010	590	560	705	571	560	505	500	
650A-7	R11	650	825	1100	650	630	777	630	630	571**	560	
721A-7	R11	721	825	1100	721	710	862	705	630	571**	560	

UL/NEC RATINGS										
ACS880-04...	Frame size	Input current	Max. current			Output ratings				
			I_1	I_{max}	I_{max_start}	App. power	Light-duty use		Heavy-duty use	
						S_n	I_{Ld}	P_{Ld}	I_{Hd}	P_{Hd}
						kVA	A	hp	A	hp
$U_n = 480\text{ V}$										
460A-5	R10	460	560	671	398	450	350	330	250	
503A-5	R10	503	560	671	435	483	400	361	300	
583A-5	R10	583	730	828	504	573	450	414	350	
635A-5	R10	635	730	954	549	623	500	477	400	
715A-5	R11	715	850	1100	619	705	600	566	450	
820A-5	R11	820	1020	1100	710	807	700	625	500	
880A-5	R11	880	1100	1100	762	857	700	697**	600	
$U_n = 575\text{ V}$										
330A-7	R10	330	480	510	393	336	350	255	250	
370A-7	R10	370	520	650	441	382	400	325	300	
430A-7	R10	430	520	720	513	424	450	360***	350	
470A-7	R11	470	655	830	562	472	500	415	450	
522A-7	R11	522	655	910	624	528	550	455	450	

UL/NEC RATINGS										
ACS880-04-...	Frame size	Input current	Max. current			Output ratings				
						App. power	Light-duty use		Heavy-duty use	
			I_1	I_{max}	I_{max_start}	S_n	I_{Ld}	P_{Ld}	I_{Hd}	P_{Hd}
A	A	A	kVA	A	hp	A	hp			
590A-7	R11	590	800	1010	705	571	600	505	500	
650A-7	R11	650	820	1100	777	630	700	571***	600	
721A-7	R11	721	820	1100	862	705	700	571***	600	

U_n	Nominal voltage of the drive. For input voltage range, see Type designation key (page 39) .
I_1	Nominal input current (rms) at 40 °C (104 °F)
I_{max}	Maximum output current. Available for 10 seconds at start, otherwise as long as allowed by drive temperature. 140% ... 200% of I_{Hd} , depending on power rating.
I_{max_start}	Maximum output current at start. Available for two seconds only at start every five seconds if start current limit is activated by parameter 30.15 Maximum start current enable.
I_2	Continuous rms output current. No overload capability at 40 °C (104 °F). This is indicated in the type designation label as output current I_2 .
P_n	Typical motor power in no-overload use
S_n	Apparent power (no overload)
I_{Ld}	Continuous rms output current allowing 10% overload for 1 minute every 5 minutes
P_{Ld}	Typical motor power for light-overload use
I_{Hd}	Continuous rms output current allowing 50% overload for 1 minute every 5 minutes *Continuous rms output current allowing 40% overload for 1 minute every 5 minutes **Continuous rms output current allowing 45% overload for 1 minute every 5 minutes ***Continuous rms output current allowing 44% overload for 1 minute every 5 minutes
P_{Hd}	Typical motor power for heavy-duty use

Note: To achieve the rated motor power given in the table, the rated current of the drive must be higher than or equal to the rated motor current. The power ratings apply to most IEC 34 motors at the nominal voltage of the drive.

ABB recommends to select the drive, motor and gear combination for the required motion profile with the DriveSize dimensioning tool available from ABB.

Output derating

■ When is derating necessary

Derate the continuous output current of the drive if

- ambient temperature exceeds +40 °C (+104 °F) or
- drive is installed higher than 1000 m (3280 ft) above sea level
- switching frequency is other than default
- the minimum requirements of motor cable length are not met (see chapter [Filters \(page 259\)](#)).

Note: The final derating factor is a multiplication of all applicable derating factors.

■ **Ambient temperature derating**

In the temperature range +40...55 °C (+104...131 °F), the rated output current is derated by 1% for every added 1 °C (1.8 °F) as follows. Calculate the output current by multiplying the current given in the rating table by the derating factor.

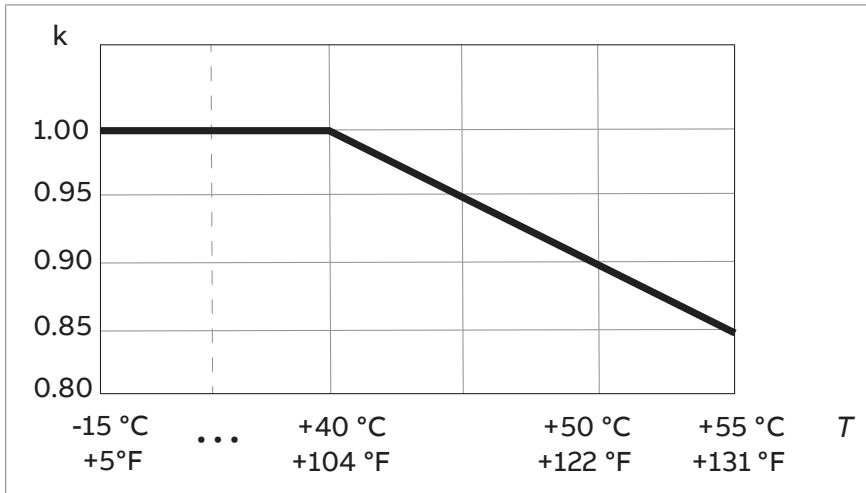

■ **Altitude derating**

At altitudes more than 1000 m (3281 ft) above sea level, the output current derating is 1 percentage point for every added 100 m (328 ft). For example, the derating factor for 1500 m (4921 ft) is 0.95. The maximum permitted installation altitude is given in the technical data.

If the surrounding air temperature is less than +40 °C (104 °F), the derating can be reduced by 1.5 percentage points for every 1 °C (1.8 °F) reduction in temperature. A few altitude derating curves are shown below.

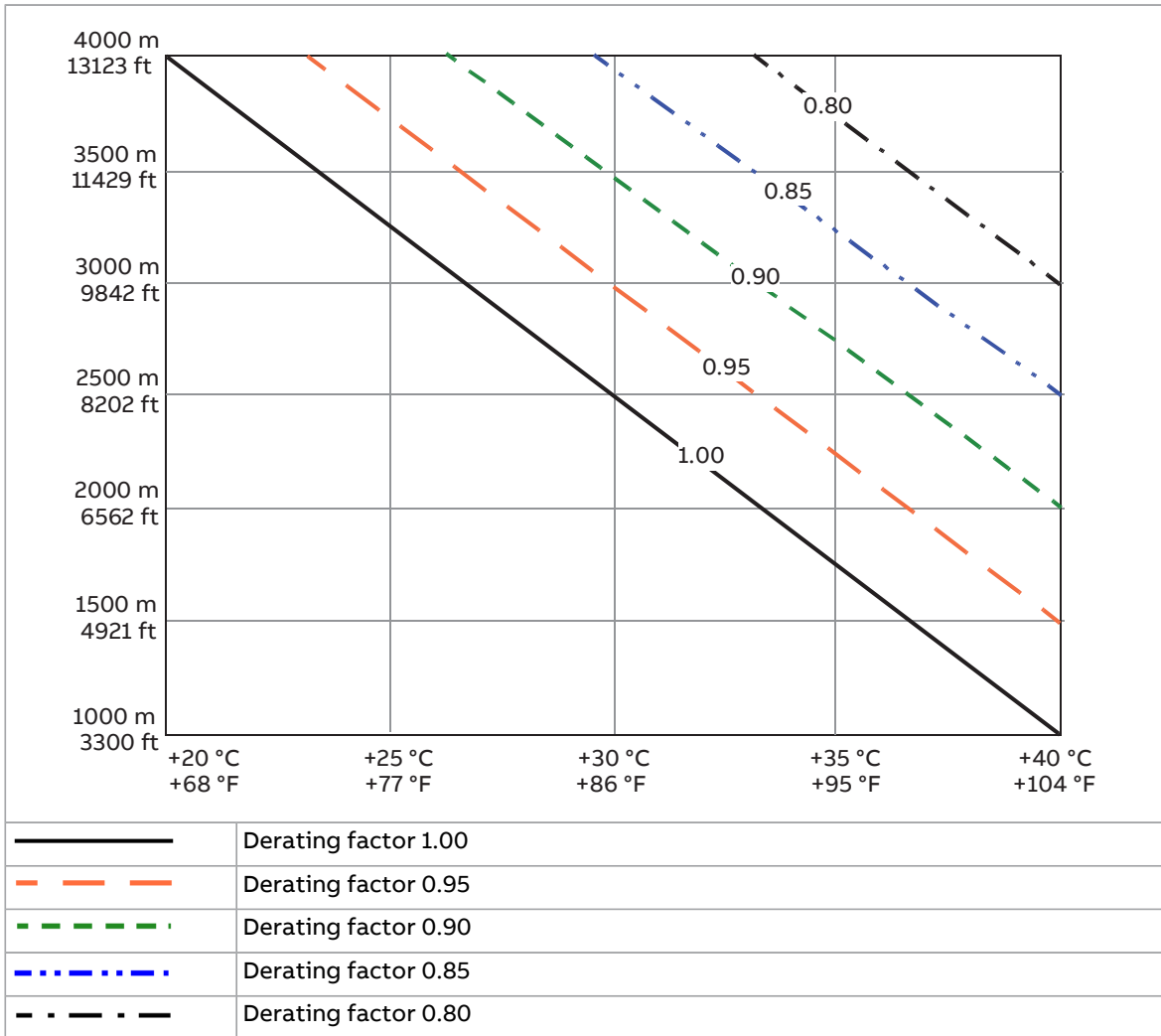

For a more accurate derating, use the DriveSize PC tool.

■ Deratings for special settings in the drive control program

Enabling special settings in the drive control program can require output current derating.

Ex motor, sine filter, low noise

Table below gives the deratings for these cases:

- drive is used with an ABB motor for explosive atmospheres (Ex) and EX motor in parameter 95.15 Special HW settings is enabled
- sine filter given in the selection table in section [Sine filters \(page 260\)](#) is used and ABB sine filter in parameter 95.15 Special HW settings is enabled
- Low noise optimization is selected in parameter 97.09 Switching freq mode.

With other than recommended sine filters (see [Sine filters \(page 260\)](#)) and non-ABB Ex motors, contact ABB.

ACS880-04-...	Output ratings for special settings											
	Ex motor (ABB Ex motor)				ABB sine filter				Low noise mode			
	Nominal use		Light-duty use	Heavy-duty use	Nominal use		Light-duty use	Heavy-duty use	Nominal use		Light-duty use	Heavy-duty use
	I_2	P_n	I_{Ld}	I_{Hd}	I_2	P_n	I_{Ld}	I_{Hd}	I_2	P_n	I_{Ld}	I_{Hd}
A	kW	A	A	A	kW	A	A	A	kW	A	A	
$U_n = 400\text{ V}$												
505A-3	479	250	459	345	470	250	450	340	390	200	370	290
585A-3	551	250	533	394	540	250	518	383	437	250	419	311
650A-3	612	315	590	438	600	315	576	425	485	250	466	346
725A-3	666	355	650	492	647	355	628	468	519	250	496	390
820A-3	753	400	736	544	731	400	712	517	587	315	562	431
880A-3	809	450	786	631	785	450	760	600	630	355	600	500*
$U_n = 500\text{ V}$												
460A-5	437	250	427	316	430	250	419	311	357	250	345	265
503A-5	478	315	458	345	470	315	450	340	390	250	370	290
583A-5	531	355	509	364	514	355	487	347	400	250	380	298
635A-5	579	400	553	419	560	400	530	400	410	250	392	298
715A-5	656	450	641	522	637	450	620	507	462	315	428	362
820A-5	752	500	734	576	730	500	710	560	530	355	490	400
880A-5	768	500	747	594	730	500	710	560	550	400	510	410
$U_n = 690\text{ V}$												
330A-7	310	250	300	217	303	250	293	204	232	200	222	157
370A-7	348	315	338	276	340	315	330	260	260	250	250	200
430A-7	378	355	368	315	360	355	350	300**	290	250	280	236**
470A-7	388	355	376	335	360	355	349	308	270	250	261	238
522A-7	430	400	417	370	400	355	388	342	300	250	290	262
590A-7	485	450	470	449	450	400	436	385	340	315	330	300
650A-7	575	500	555	480	550	500	530	450**	450	400	430	350**
721A-7	593	500	574	480	550	500	530	450**	450	400	430	350**

U_n	Nominal voltage of the drive
I_2	Nominal output current (rms) at 40 °C (104 °F)
P_n	Typical motor power in no-overload use
I_{Ld}	Continuous rms output current allowing 10% overload for 1 minute every 5 minutes
I_{Hd}	Continuous rms output current allowing 50% overload for 1 minute every 5 minutes *Continuous rms output current allowing 40% overload for 1 minute every 5 minutes **Continuous rms output current allowing 44% overload for 1 minute every 5 minutes

Note: To achieve the rated motor power given in the table, the rated current of the drive must be higher than or equal to the rated motor current. The power ratings apply to most IEC 34 motors at the nominal voltage of the drive.

ABB recommends to select the drive, motor and gear combination for the required motion profile with the DriveSize dimensioning tool available from ABB.

■ High speed mode

The selection **High speed mode** of parameter 95.15 Special HW settings improves control performance at high output frequencies. ABB recommends it to be selected with output frequency of 120 Hz and above.

This table gives the drive module ratings for 120 Hz output frequency and the maximum output frequency when **High speed mode** in parameter 95.15 Special HW settings is enabled. With output frequencies lower than the maximum output frequency, the current derating is less than the value given in the table. Contact ABB for operation above the recommended maximum output frequency or for the output current derating with output frequencies above 120 Hz and below the maximum output frequency.

ACS880-04-...	Deratings with selection High speed mode of parameter 95.15 Special HW settings									
	120 Hz output frequency					Maximum output frequency				
	Fre- quency	Nominal use		Light- duty use	Heavy- duty use	Maxim- um fre- quency	Nominal use		Light- duty use	Heavy- duty use
	f	I_2	P_n	I_{Ld}	I_{Hd}	f_{max}	I_2	P_n	I_{Ld}	I_{Hd}
Hz	A	kW	A	A	Hz	A	kW	A	A	
$U_n = 400\text{ V}$										
505A-3	120	505	250	485	361	500	390	200	370	290
585A-3	120	585	315	575	429	500	437	250	419	311
650A-3	120	650	355	634	477	500	485	250	466	346
725A-3	120	725	400	715	566	500	519	250	496	390
820A-3	120	820	450	810	625	500	587	315	562	431
880A-3	120	880	500	865	725*	500	630	355	600	500*
$U_n = 500\text{ V}$										
460A-5	120	460	315	450	330	500	357	250	345	265
503A-5	120	503	355	483	361	500	390	250	370	290
583A-5	120	583	400	573	414	500	400	250	380	298
635A-5	120	635	450	623	477	500	410	250	392	298
715A-5	120	715	500	705	566	500	462	315	428	362
820A-5	120	820	560	807	625	500	530	355	490	400
880A-5	120	880	630	857	697**	500	550	400	510	410
$U_n = 690\text{ V}$										
330A-7	120	330	315	320	255	375	232	200	222	157
370A-7	120	370	355	360	325	375	260	250	250	200
430A-7	120	430	400	420	360***	375	290	250	280	236***
470A-7	120	470	450	455	415	375	270	250	261	238
522A-7	120	522	500	505	455	375	300	250	290	262
590A-7	120	590	560	571	505	375	340	315	330	300

ACS880-04-...	Deratings with selection High speed mode of parameter 95.15 Special HW settings									
	120 Hz output frequency					Maximum output frequency				
	Fre- quency	Nominal use		Light- duty use	Heavy- duty use	Maxim- um fre- quency	Nominal use		Light- duty use	Heavy- duty use
	f	I_2	P_n	I_{Ld}	I_{Hd}	f_{max}	I_2	P_n	I_{Ld}	I_{Hd}
	Hz	A	kW	A	A	Hz	A	kW	A	A
650A-7	120	650	630	630	571***	375	450	400	430	350***
721A-7	120	721	710	705	571***	375	450	400	430	350***

f	Output frequency
f_{max}	Maximum output frequency with High speed mode
U_n	Nominal voltage of the drive
I_2	Continuous rms output current. No overload capability at 40 °C (104 °F).
P_n	Typical motor power in no-overload use
I_{Ld}	Continuous rms output current allowing 10% overload for 1 minute every 5 minutes
I_{Hd}	Continuous rms output current allowing 50% overload for 1 minute every 5 minutes *Continuous rms output current allowing 40% overload for 1 minute every 5 minutes **Continuous rms output current allowing 45% overload for 1 minute every 5 minutes ***Continuous rms output current allowing 44% overload for 1 minute every 5 minutes

Fuses (IEC)

aR fuses by Cooper Bussmann for protection against short-circuit in the input power cable of the drive are listed below.

ACS880-04...	Ultrarapid (aR) fuses per drive module						
	Min. short-circuit current	Input current	Fuse				
	A	A	A	A ² s	V	Type DIN 43653	Size
$U_n = 400\text{ V}$							
505A-3	4500	505	800	465000	690	170M6012	3
585A-3	6500	585	1000	945000	690	170M6014	3
650A-3	6500	650	1000	945000	690	170M6014	3
725A-3	9100	725	1250	1950000	690	170M6016	3
820A-3	11000	820	1600	3900000	690	170M6019	3
880A-3	11000	880	1600	3900000	690	170M6019	3
$U_n = 500\text{ V}$							
460A-5	3000	460	630	210000	690	170M6010	3
503A-5	4500	505	800	465000	690	170M6012	3
583A-5	6500	585	1000	945000	690	170M6014	3
635A-5	6500	650	1000	945000	690	170M6014	3
715A-5	9100	725	1250	1950000	690	170M6016	3
820A-5	11000	820	1600	3900000	690	170M6019	3
880A-5	11000	880	1600	3900000	690	170M6019	3
$U_n = 690\text{ V}$							
330A-7	3600	330	700	300000	690	170M6011	3
370A-7	5600	370	900	670000	690	170M6013	3
430A-7	6500	430	1000	945000	690	170M6014	3
470A-7	7800	470	1100	1300000	690	170M6015	3
522A-7	9100	522	1250	1950000	690	170M6016	3
590A-7	10200	590	1400	2450000	690	170M6017	3
650A-7	10500	650	1500	3100000	690	170M6018	3
721A-7	10500	721	1500	3100000	690	170M6018	3

Note: In multicable installations, install only one fuse per phase (not one fuse per conductor).

Fuses with higher current rating than the recommended ones must not be used. Fuses with lower current rating can be used.

Fuses from other manufacturers can be used if they agree with the ratings and the melting curve of the fuse does not exceed the melting curve of the fuse mentioned in the table.

■ Calculating the short-circuit current of the installation

Make sure that the short-circuit current of the installation is at least the value given in the fuse table.

The short-circuit current of the installation can be calculated as follows:

$$I_{k2-ph} = \frac{U}{2 \cdot \sqrt{R_c^2 + (Z_k + X_c)^2}}$$

where

I_{k2-ph}	Short-circuit current in symmetrical two-phase short-circuit
U	Network line-to-line voltage (V)
R_c	Cable resistance (ohm)
Z_k	$Z_k = z_k \cdot U_n^2 / S_n =$ transformer impedance (ohm)
z_k	Transformer impedance (%)
U_n	Transformer rated voltage (V)
S_n	Nominal apparent power of the transformer (kVA)
X_c	Cable reactance (ohm)

Calculation example

Drive:

- ACS880-04-715A-5
- Supply voltage = 500 V

Transformer:

- rated power $S_n = 5000$ kVA
- rated voltage (drive supply voltage) $U_N = 480$ V
- transformer impedance $z_k = 10\%$.

Supply cable:

- length = 170 m
- resistance/length = 0.125 ohm/km
- reactance/length = 0.074 ohm/km.

$$Z_k = z_k \cdot \frac{U_N^2}{S_N} = 0.1 \cdot \frac{(480 \text{ V})^2}{5000 \text{ kVA}} = 4.61 \text{ mohm}$$

$$R_c = 170 \text{ m} \cdot 0.125 \frac{\text{ohm}}{\text{km}} = 21.25 \text{ mohm}$$

$$X_c = 170 \text{ m} \cdot 0.074 \frac{\text{ohm}}{\text{km}} = 12.58 \text{ mohm}$$

$$I_{k2-ph} = \frac{500 \text{ V}}{2 \cdot \sqrt{(21.25 \text{ mohm})^2 + (4.61 \text{ mohm} + 12.58 \text{ mohm})^2}} = 9.15 \text{ kA}$$

The calculated short-circuit current 9.15 kA is higher than the minimum short-circuit current of the drive aR fuse type 170M6016 (9100 A). -> The 690 V aR fuse (170M6016) can be used.

Fuses (UL)

UL fuses for branch circuit protection per NEC per drive module are listed below. Obey the local regulations. The listed fuses do not include trip indicators by default.

ACS880-04...	UL fuses per drive module					
	Input current (A)	Fuse				
		A	V	Manufacturer	UL class	Type
$U_n = 480\text{ V}$						
460A-5	460	600	600	Bussmann	T	JJS-600
503A-5	505	600	600	Bussmann	T	JJS-600
583A-5	585	800	600	Ferraz	L	A4BY800
635A-5	650	800	600	Ferraz	L	A4BY800
715A-5	725	1000	600	Ferraz	L	A4BY1000
820A-5	820	1000	600	Ferraz	L	A4BY1000
880A-5	880	1000	600	Ferraz	L	A4BY1000
$U_n = 575\text{ V}$						
330A-7	330	500	600	Bussmann	T	JJS-500
370A-7	370	500	600	Bussmann	T	JJS-500
430A-7	430	500	600	Bussmann	T	JJS-500
470A-7	470	600	600	Bussmann	T	JJS-600
522A-7	522	600	600	Bussmann	T	JJS-600
590A-7	590	800	600	Ferraz	L	A4BY800
650A-7	650	800	600	Ferraz	L	A4BY800
721A-7	721	800	600	Ferraz	L	A4BY800

1. Fuses are required as part of the installation, are not included in the base drive configuration and must be provided by others.
2. Fuses with a higher current rating than specified must not be used.
3. The UL listed fuses recommended by ABB are the required branch circuit protection per NEC. Circuit breakers listed in section Circuit breakers (UL) are also acceptable as branch circuit protection.
4. The recommended size or smaller UL listed 248 fast acting, time delay, or high speed fuses must be used to maintain the UL listing of the drive. Additional protection can be used. Refer to local codes and regulations.
5. A fuse of a different class can be used at the high fault rating where the I_{peak} and I^2t of the new fuse is not greater than that of the specified fuse.
6. UL listed 248 fast acting, time delay, or high speed fuses from other manufacturers can be used if they meet the same class and rating requirements specified in the rules above.
7. When you install a drive, always obey ABB installation instructions, NEC requirements and local codes.
8. Alternative fuses can be used if they meet certain characteristics. For permitted fuses, see [Branch Circuit Protection for ABB drives manual supplement \(3AXD50000645015\)](#).

In multicable installations, install only one fuse per phase (not one fuse per conductor).

Circuit breakers

The protective characteristics of circuit breakers depend on the type, construction and settings of the breakers. There are also limitations pertaining to the short-circuit capacity of the supply network. Your local ABB representative can help you in selecting the breaker type when the supply network characteristics are known.

You can use the circuit breakers listed below. Other circuit breakers can be used with the drive if they provide the same electrical characteristics. ABB does not assume any liability whatsoever for the correct function and protection with circuit breakers not listed below. Furthermore, if the recommendations given by ABB are not obeyed, the drive can experience problems that the warranty does not cover.

Drive module type	Frame size	ABB molded case circuit breaker (Tmax)	kA ¹⁾
		Product ID (Type)	
$U_n = 400\text{ V}$			
ACS880-04-505A-3	R10	1SDA054412R1 (T5H 630 PR221DS-LS/I In=630 3p F F)	30
ACS880-04-585A-3	R10	1SDA069428R1 (T6V 800 PR221DS-LS/I In=800 3p F F)	30
ACS880-04-650A-3	R10	1SDA069428R1 (T6V 800 PR221DS-LS/I In=800 3p F F)	30
ACS880-04-725A-3	R11	1SDA062770R1 (T7H 1000 PR231/P LS/I In=1000A 3p F F)	50
ACS880-04-820A-3	R11	1SDA062770R1 (T7H 1000 PR231/P LS/I In=1000A 3p F F)	50
ACS880-04-880A-3	R11	1SDA062770R1 (T7H 1000 PR231/P LS/I In=1000A 3p F F)	50
$U_n = 500\text{ V}$			
ACS880-04-460A-5	R10	1SDA054412R1 (T5H 630 PR221DS-LS/I In=630 3p F F)	30
ACS880-04-503A-5	R10	1SDA054412R1 (T5H 630 PR221DS-LS/I In=630 3p F F)	30
ACS880-04-583A-5	R10	1SDA054412R1 (T5H 630 PR221DS-LS/I In=630 3p F F)	30
ACS880-04-635A-5	R10	1SDA069428R1 (T6V 800 PR221DS-LS/I In=800 3p F F)	30
ACS880-04-715A-5	R11	1SDA062770R1 (T7H 1000 PR231/P LS/I In=1000A 3p F F)	50
ACS880-04-820A-5	R11	1SDA062770R1 (T7H 1000 PR231/P LS/I In=1000A 3p F F)	50
ACS880-04-880A-5	R11	1SDA062770R1 (T7H 1000 PR231/P LS/I In=1000A 3p F F)	50
$U_n = 690\text{ V}$			
ACS880-04-330A-7	R10	1SDA054412R1 (T5H 630 PR221DS-LS/I In=630 3p F F)	30

Drive module type	Frame size	ABB molded case circuit breaker (Tmax)	
		Product ID (Type)	kA ¹⁾
ACS880-04-370A-7	R10	1SDA054412R1 (T5H 630 PR221DS-LS/I In=630 3p F F)	30
ACS880-04-430A-7	R10	1SDA054412R1 (T5H 630 PR221DS-LS/I In=630 3p F F)	30
ACS880-04-470A-7	R11	1SDA054412R1 (T5H 630 PR221DS-LS/I In=630 3p F F)	30
ACS880-04-522A-7	R11	1SDA069428R1 (T6V 800 PR221DS-LS/I In=800 3p F F)	40
ACS880-04-590A-7	R11	1SDA069428R1 (T6V 800 PR221DS-LS/I In=800 3p F F)	40
ACS880-04-650A-7	R11	2)	2)
ACS880-04-721A-7	R11	2)	2)

¹⁾ Maximum allowed rated conditional short-circuit current (IEC 61439-1) of the electrical power network

²⁾ Contact your local ABB representative



⚠ WARNING Due to the inherent operating principle and construction of circuit breakers, independent of the manufacturer, hot ionized gases can escape from the breaker enclosure in case of a short-circuit. To ensure safe use, pay special attention to the installation and placement of the breakers. Obey the manufacturer's instructions.

Dimensions, weights and free space requirements

Standard drive module configuration								
Frame size	Height		Width		Depth		Weight*	
	mm	in	mm	in	mm	in	kg	lb
R10	1541	60.67	350	14.82	506	19.92	161	355
R11	1741	68.54	350	14.82	506	19.92	199	439

Optional selection +0B051+0H371 (without shrouds and full-size output power cable connection terminals)								
Frame size	Height		Width		Depth		Weight*	
	mm	in	mm	in	mm	in	kg	lb
R10	1462	57.56	305	12.01	506	19.92	156	345
R11	1662	65.43	305	12.01	506	19.92	194	429

Optional selection +H381 (full power cabling panels)								
Frame size	Height		Width		Depth		Weight*	
	mm	in	mm	in	mm	in	kg	lb
R10	1590	62.62	329	12.95	516	19.92	196	432
R11	1740	68.58	329	12.95	516	19.92	233	514

* approximate (depends on the selected options)

Weight of optional selections														
Frame size	+H354		+E208		+D150		+H356		+OH371		+H370		+OB051	
	kg	lb	kg	lb	kg	lb	kg	lb	kg	lb	kg	lb	kg	lb
R10	-7	-15	3	7	10	22	2	4	-2.9	-6	2.9	6	-1.5	-3
R11	-7	-15	3	7	9	20	2	4	-2.9	-6	2.9	6	-1.5	-3

The weight of the cabling panels of option +H381 is 30 kg (66 lb).

Height of drive module without pedestal (option +OH354)		
Frame size	mm	in
R10, R11	-100	-3.94

Additional depth with option +C173 when the mounting brackets are used: 18.5 mm (0.73 in)

For the free space requirements, refer to section [Free space requirements \(page 54\)](#).

Losses, cooling data and noise

ACS880-04...	Frame size	Air flow		Heat dissipation ¹⁾	Noise
		m ³ /h	ft ³ /min	W	dB(A)
U_n = 400 V					
505A-3	R10	1200	707	6454	72
585A-3	R10	1200	707	6763	72
650A-3	R10	1200	707	7971	72
725A-3	R11	1200	707	8002	72
820A-3	R11	1200	707	9547	72
880A-3	R11	1420	848	10773	71
U_n = 500 V					
460A-5	R10	1200	707	5753	72
503A-5	R10	1200	707	6615	72
583A-5	R10	1200	707	6859	72
635A-5	R10	1200	707	7845	72
715A-5	R11	1200	707	7969	72
820A-5	R11	1420	848	9796	71
880A-5	R11	1420	848	10899	71
U_n = 690 V					
330A-7	R10	1200	707	4846	72
370A-7	R10	1200	707	5749	72
430A-7	R10	1200	707	7117	72
470A-7	R11	1200	707	6294	72
522A-7	R11	1200	707	7290	72
590A-7	R11	1200	707	8753	72
650A-7	R11	1420	848	8283	71
721A-7	R11	1420	848	9549	71

¹⁾ Typical drive losses when it operates at 90% of the motor nominal frequency and 100% of the drive nominal output current (calculated according to IEC61800-9-2).

The cooling air temperature rises 30 degrees Celsius when it goes through the drive module if the temperature of the input cooling air is 40 degrees Celsius.

Typical power cables

The table below gives typical copper and aluminum cable types with concentric copper shield for the drive modules with nominal current. See also section [Terminal and entry data for the power cables \(page 197\)](#).

ACS880-04...	IEC ¹⁾		US ²⁾	
	Cu cable type	Al cable type	Cu cable type	Al cable type
	mm ²	mm ²	AWG/kcmil	AWG/kcmil
U_n = 400 V				
505A-3	3×(3×95)	3×(3×150)	2×500 MCM or 3×250 MCM	2×700 MCM or 3×350 MCM
585A-3	3×(3×120)	3×(3×185)	2×600 MCM or 3×300 MCM	3×400 MCM or 4×250 MCM
650A-3	3×(3×150)	3×(3×240)	2×700 MCM or 3×350 MCM	3×400 MCM or 4×250 MCM
725A-3	3×(3×185)	4×(3×185)	3×500 MCM or 4×300 MCM	3×500 MCM or 4×300 MCM
820A-3	3×(3×240)	4×(3×240)	3×600 MCM or 4×400 MCM	3×700 MCM or 4×500 MCM
880A-3	3×(3×240)	4×(3×240)	3×600 MCM or 4×400 MCM	4×500 MCM
U_n = 500 V				
460A-5	3×(3×95)	3×(3×150)	2×400 MCM or 3×4/0	2×600 MCM or 3×300 MCM
503A-5	3×(3×95)	3×(3×150)	2×500 MCM or 3×250 MCM	2×700 MCM or 3×350 MCM
583A-5	3×(3×120)	3×(3×185)	2×600 MCM or 3×300 MCM	3×500 MCM or 4×300 MCM
635A-5	3×(3×150)	3×(3×240)	2×700 MCM or 3×350 MCM	3×600 MCM or 4×400 MCM
715A-5	3×(3×185)	4×(3×185)	3×500 MCM or 4×300 MCM	3×600 MCM or 4×400 MCM
820A-5	3×(3×240)	4×(3×240)	3×600 MCM or 4×400 MCM	4×500 MCM
880A-5	3×(3×240)	4×(3×240)	3×600 MCM or 4×400 MCM	4×500 MCM
U_n = 690 V				
330A-7	2×(3×95)	2×(3×120)	2×300 MCM or 3×3/0	2×350 MCM or 3×4/0
370A-7	2×(3×95)	2×(3×120)	2×300 MCM or 3×3/0	2×400 MCM or 3×4/0
430A-7	2×(3×95)	2×(3×120)	2×350 MCM or 3×4/0	2×500 MCM or 3×250 MCM
470A-7	3×(3×95)	3×(3×150)	2×400 MCM or 3×4/0	2×600 MCM or 3×300 MCM
522A-7	3×(3×120)	3×(3×185)	2×500 MCM or 3×250 MCM	2×700 MCM or 3×350 MCM
590A-7	3×(3×150)	3×(3×185)	2×600 MCM or 3×300 MCM	3×500 MCM or 4×300 MCM
650A-7	3×(3×150)	3×(3×240)	2×700 MCM or 3×350 MCM	3×500 MCM or 4×300 MCM
721A-7	3×(3×185)	4×(3×185)	3×500 MCM or 4×300 MCM	3×600 MCM or 4×400 MCM

¹⁾ The cable selection is based on max. 9 cables laid on a cable ladder side by side, three ladder type trays one on top of the other, ambient temperature 30 °C (86 °F) PVC insulation, surface temperature 70 °C (158 °F) (EN 60204-1 and IEC 60364-5-52). For other conditions, select the cables according to local safety regulations, appropriate input voltage and the load current of the drive.

²⁾ The cable selection is based on NEC Table 310-16 for copper wires, 75 °C (167 °F) wire insulation at 40 °C (104 °F) ambient temperature. Not more than three current-carrying conductors in raceway or cable or earth (directly buried). For other conditions, dimension the cables according to local safety regulations, appropriate input voltage and the load current of the drive.

Temperature: For IEC, select a cable rated for at least 70 °C maximum permissible temperature of conductor in continuous use. For North America, power cables must be rated for 75 °C (167 °F) or higher.

Voltage: 600 V AC cable is accepted for up to 500 V AC. 750 V AC cable is accepted for up to 600 V AC. 1000 V AC cable is accepted for up to 690 V AC.

Terminal and entry data for the power cables

The maximum accepted cable size is $4 \times (3 \times 240)$ mm² or $4 \times (3 \times 500)$ MCM). Screw size for connecting busbars to the drive module input and output busbars: M12, tightening torque 50...75 N·m (37...55 lbf·ft).

■ Units with optional cabling panels (+H381)

The maximum accepted cable size is $4 \times (3 \times 240)$ mm² or $4 \times (3 \times 500)$ MCM). The cabling panels are connected to the drive module busbars with M12 serpress nuts, tightening torque 30 N·m (20 lbf·ft).

■ Units without full-size output cable connection terminals (+0H371) and with a common mode filter (+E208)

It is possible to use the maximum cable size ($4 \times [3 \times 240]$ mm² or $4 \times [3 \times 500]$ MCM) only with special cable lugs and additional insulation. For more information, contact your local ABB representative.

Terminal data for the control cables

See section [Default control connection diagram of the drive control unit \(ZCU\) \(page 123\)](#)

Electrical power network specification

Voltage (U_1)	<p>ACS880-04-xxxx-3 drives: 380...415 VAC 3-phase +10%...-15%. This is indicated in the type designation label as typical input voltage level 3~400 V AC.</p> <p>ACS880-04-xxxx-5 drives: 380...500 V AC 3-phase +10%...-15%. This is indicated in the type designation label as typical input voltage levels 3~400/480/500 V AC.</p> <p>ACS880-04-xxxx-7 drives: 525...690 V AC 3-phase +10%...-15%. This is indicated in the type designation label as typical input voltage levels 3~525/600/690 V AC.</p>
Network type	TN (grounded) and IT (ungrounded) systems
Rated conditional short-circuit current I_{cc} (IEC 61800-5-1)	Maximum allowable prospective short-circuit current is 65 kA when protected by the fuses given in the fuse table.
Maximum prospective short-circuit current rating (SCCR) (UL 61800-5-1, CSA C22.2 No. 274-17)	The drive is suitable for use on a circuit capable of delivering not more than 100 kA rms symmetrical amperes at 600 V maximum when protected by the fuses given in the fuse table.
Frequency (f_1)	50/60 Hz. Variation $\pm 5\%$ of nominal frequency.
Imbalance	Max. $\pm 3\%$ of nominal phase to phase input voltage
Fundamental power factor ($\cos \phi_1$)	0.98 (at nominal load)

Motor connection data

Motor types	Asynchronous AC induction motors, permanent magnet motors, AC induction servomotors and ABB synchronous reluctance motors (SynRM motors).
-------------	---

Voltage (U_2)	This is indicated in the type designation label as typical output voltage level $3 \sim 0 \dots U_1$.
Frequency (f_2)	0...598 Hz <u>For drives with du/dt filter:</u> 200 Hz <u>For drives with sine filter:</u> 120 Hz
Frequency resolution	0.01 Hz
Current	See section Electrical ratings (page 181) .
Switching frequency	3 kHz (typically)
Maximum recommended motor cable length	<u>DTC control:</u> 500 m (1640 ft) <u>Scalar control:</u> 500 m (1640 ft) Note: With motor cables longer than 100 m (328 ft), the EMC Directive requirements may not be fulfilled. Note: Long cables cause a motor voltage decrease which limits the available motor power. The decrease depends on the motor cable length and characteristics. Contact ABB for more information. Note that a sine filter (optional) at the drive output also causes a voltage decrease.
Minimum recommended motor cable length	<u>For drive modules without du/dt filter:</u> 2 m (7 ft) from each drive module to the motor or 4 m (13 ft) between the drive modules, possible only with special precautions, see section du/dt filters (page 259) . The motor cabling must be symmetrical.

Brake resistor data

See section [Ratings \(page 257\)](#).

du/dt and sine filters

See section [Filters \(page 259\)](#).

DC connection data

Drive type	I_{DC} (A)	Capacitance (mF)
$U_n = 400$ V		
ACS880-04-505A-3	640	14.0
ACS880-04-585A-3	714	14.0
ACS880-04-650A-3	870	14.0
ACS880-04-725A-3	909	21.0
ACS880-04-820A-3	1033	21.0
ACS880-04-880A-3	1120	21.0
$U_n = 500$ V		
ACS880-04-460A-5	487	14.0
ACS880-04-503A-5	640	14.0
ACS880-04-583A-5	714	14.0
ACS880-04-635A-5	870	14.0
ACS880-04-715A-5	906	21.0
ACS880-04-820A-5	1033	21.0
ACS880-04-880A-5	1120	21.0
$U_n = 690$ V		
ACS880-04-330A-7	429	4.7
ACS880-04-370A-7	481	4.7
ACS880-04-430A-7	559	4.7
ACS880-04-470A-7	611	9.3
ACS880-04-522A-7	679	9.3
ACS880-04-590A-7	767	9.3
ACS880-04-650A-7	845	9.3
ACS880-04-721A-7	937	9.3

Control panel type

ACS-AP-W assistant control panel with Bluetooth connection.

Efficiency

Approximately 98% at nominal power level.

The efficiency is not calculated according to the ecodesign standard IEC 61800-9-2.

Energy efficiency data (ecodesign)

Energy efficiency data according to IEC 61800-9-2 is available from the ecodesign tool (<https://ecodesign.drivesmotors.abb.com>). The drive complies with the IE efficiency class IE2.



Protection classes

Degrees of protection (IEC/EN 60529)	IP20 (standard and with option +H381) IP00 (option +0B051) Heatsink: IP55
Enclosure types (UL 50/50E)	UL Open Type Heatsink: UL Type 12
Overvoltage category (IEC/EN 60664-1)	III
Protective class (IEC/EN 61800-5-1)	I

Ambient conditions

Environmental limits for the drive, including installed options, are given below. The drive is to be used in a heated, indoor, controlled environment.

	Operation (installed for stationary use)	Storage (in the protective pack- age)	Transportation (in the protective pack- age)
Installation site altitude	<p><u>For TN and TT neutral-grounded network systems and IT non-corner-grounded network systems:</u> 0 to 4000 m (13123 ft) above sea level</p> <p><u>For corner-grounded network systems:</u> 0 to 2000 m (6561 ft) above sea level</p> <p><u>Above 1000 m (3281 ft):</u> see section When is derating necessary (page 183)</p>	-	-
Surrounding air temperature	-15...+55 °C (5...131 °F). No frost allowed. See section When is derating necessary (page 183)	-40... 70 °C (-40...+158 °F)	-40...+70 °C (-40...+158 °F)
Relative humidity	5...95%	5...95%	5...95%
	No condensation allowed. Maximum allowed relative humidity is 60% ¹⁾ in the presence of corrosive gases at level C4.		
Contamination levels	IEC60721-3-3:2019, ISO9223 ANSI-ISA 71.04	IEC 60721-3-1:1997	IEC 60721-3-2:1997
Chemical gases	<p>IP00, IP20 and IP21 drives: IEC Class C3 ANSI-ISA 71.04 Class G2</p> <p>IP55 drives: IEC Class C4 ANSI-ISA 71.04 G3/GX up to 2300 Å/30d corrosivity</p> <p>Drives with +P968 corrosion resistance variant: IEC Class C5/CX ANSI-ISA 71.04 GX up to 8000 Å/30d corrosivity</p>	Class 1C2	Class 2C2
	Conformal coated circuit boards as standard on all drives		
Solid particles	Class 3S6. No conductive dust allowed.	Class 1S3 if the package is Class 2S2, otherwise Class 1S2	Class 2S2

	Operation (installed for stationary use)	Storage (in the protective pack- age)	Transportation (in the protective pack- age)
Pollution degree IEC/EN 60664-1	2		
Atmospheric pressure	70...106 kPa (0.7 ... 1.05 atmospheres)	70...106 kPa (0.7 ... 1.05 atmospheres)	60...106 kPa (0.6 ... 1.05 atmospheres)
Vibration IEC 60068-2-6:2007, EN 60068-2-6:2008	Max. 0.1 mm (0.004 in) (10...57 Hz), max. 10 m/s ² (33 ft/s ²) (57...150 Hz) sinusoidal	Max. 1 mm (0.04 in) (5 ... 13.2 Hz), max. 7 m/s ² (23 ft/s ²) (13.2...100 Hz) sinusoidal	Max. 3.5 mm (0.14 in) (2...9 Hz), max. 15 m/s ² (49 ft/s ²) (9...200 Hz) si- nusoidal
Shock IEC 60068-2-27:2008, EN 60068-2-27:2009	Not allowed	With packing max. 100 m/s ² (330 ft/s ²), 11 ms	With packing max. 100 m/s ² (330 ft/s ²), 11 ms
Free fall	Not allowed	100 mm (4 in) for weight over 100 kg (220 lb)	100 mm (4 in) for weight over 100 kg (220 lb)

¹⁾ Contact ABB for higher humidity levels than 60% in the presence of corrosive gases.

Storage conditions

Store the drive in humidity controlled enclosed environments. Keep the drive in its package.

Colors

RAL 9002

Materials

■ Drive

See [Recycling instructions and environmental information for ACS880-04, ACS880-04F, ACS880-14, ACS880-34, ACS580-04, ACH580-04, ACH580-34, ACQ580-04 and ACQ580-34 drives \(3AXD50000137688 \[English\]\)](#).

■ Package materials for module products

This is a complete list of the package materials. The materials vary depending on the frame size (packages do not contain all materials listed below).

- Cardboard (heavy duty quality with wet strength glue in large modules)
 - Molded pulp
 - Plywood
 - Wood
 - PP (strapping)
 - EPP (foam)
 - PE (plastic bag and/or VCI film)
 - Metal (fixing clamps, screws).
-

■ **Package materials for options, accessories and spare parts**

- Cardboard
- Kraft paper
- PP (straps)
- PE (film, bubble wrap)
- Plywood, wood (only for heavy components)

The materials vary according to the item type, size and shape. The typical package is a cardboard box with paper filling or bubble wrap. ESD-safe packing materials are used for printed circuit boards and similar items.

■ **Materials of manuals**

Printed product manuals are made of recyclable paper. Product manuals are available on the Internet.

Disposal

The main parts of the drive can be recycled to preserve natural resources and energy. Product parts and materials should be dismantled and separated.

Generally all metals, such as steel, aluminum, copper and its alloys, and precious metals can be recycled as material. Plastics, rubber, cardboard and other packaging material can be used in energy recovery.

Printed circuit boards and DC capacitors need selective treatment according to IEC 62635 guidelines.

To aid recycling, most plastic parts are marked with an appropriate identification code. In addition, components containing Substances of Very High Concern (SVHCs) are listed in the European Chemicals Agency SCIP database. SCIP is the database for information on Substances of Concern in articles as such or in complex objects (Products) established under the Waste Framework Directive (2008/98/EC). For more information, contact your local ABB distributor or consult the European Chemicals Agency SCIP database to find out which SVHCs are used in the drive and where the components are located.

Contact your local ABB distributor for more information on environmental aspects. End of life treatment must follow international and national regulations.

For more information on ABB end of life services, refer to new.abb.com/service/end-of-life-services.

Applicable standards

The drive complies with the following standards.

<p>EN 61800-5-1:2007 + A1:2017 + A11:2021 IEC 61800-5-1:2007 + Amd1:2016</p>	<p>Adjustable speed electrical power drive systems. Part 5-1: Safety requirements – electrical, thermal and energy</p>
--	--

204 Technical data

EN 60204-1:2006 +A1:2010	Safety of machinery. Electrical equipment of machines. Part 1: General requirements. Provisions for compliance: The final assembler of the machine is responsible for installing <ul style="list-style-type: none"> • emergency-stop device • supply disconnecting device • IP00 drive module into a cabinet.
IEC 60529:1989 + A1:1999 + A2:2013 EN 60529:1991 + A1:2000 + A2:2013	Degrees of protection provided by enclosures (IP code)
IEC 61800-3:2004 + A1:2011 EN 61800-3:2004 + A1:2012	Adjustable speed electrical power drive systems. Part 3: EMC requirements and specific test methods
UL 61800-5-1 First edition	Standard for Adjustable Speed Electrical Power Drive Systems – Part 5-1: Safety Requirements – Electrical, Thermal and Energy
CSA C22.2 No. 0-10	General Requirements - Canadian Electrical Code, Part II
CSA C22.2 No. 274-17	Adjustable speed drives

Markings

These markings are attached to the drive:





	CE mark Product complies with the applicable European Union legislation. For fulfilling the EMC requirements, see the additional information concerning the drive EMC compliance (IEC/EN 61800-3).
---	---

	UL Listed mark for USA and Canada Product has been tested and evaluated against the relevant North American standards by the Underwriters Laboratories. Valid with rated voltages up to 600 V.
---	---

	TÜV Safety Approved mark (functional safety) Product contains Safe torque off and possibly other (optional) safety functions which are certified by TÜV according to the relevant functional safety standards. Applicable to drives and inverters; not applicable to supply, brake or DC/DC converter units or modules.
---	--

	CSA certification mark for USA and Canada Product has been tested and evaluated against the relevant North American standards by the CSA Group. Valid with rated voltages up to 600 V.
---	---

	EAC (Eurasian Conformity) mark Product complies with the technical regulations of the Eurasian Customs Union. EAC mark is required in Russia, Belarus and Kazakhstan.
---	--

	<p>Electronic Information Products (EIP) symbol including an Environment Friendly Use Period (EFUP).</p> <p>Product is compliant with the People's Republic of China Electronic Industry Standard (SJ/T 11364-2014) about hazardous substances. The EFUP is 20 years. China RoHS II Declaration of Conformity is available from https://library.abb.com.</p>
	<p>RCM mark</p> <p>Product complies with Australian and New Zealand requirements specific to EMC, telecommunications and electrical safety. For fulfilling the EMC requirements, see the additional information concerning the drive EMC compliance (IEC/EN 61800-3).</p>
	<p>KC mark</p> <p>Product complies with Korean Registration of Broadcasting and Communications Equipment Clause 3, Article 58-2 of Radio Waves Act.</p>
	<p>WEEE mark</p> <p>At the end of life the product should enter the recycling system at an appropriate collection point and not placed in the normal waste stream.</p>
	<p>UKCA (UK Conformity Assessed) mark</p> <p>Product complies with the applicable United Kingdom's legislation (Statutory Instruments). Marking is required for products being placed on the market in Great Britain (England, Wales and Scotland).</p>

EMC compliance (IEC/EN 61800-3)

■ Definitions

EMC stands for Electromagnetic Compatibility. It is the ability of electrical/electronic equipment to operate without problems within an electromagnetic environment. Likewise, the equipment must not disturb or interfere with any other product or system within its locality.

First environment includes establishments connected to a low-voltage network which supplies buildings used for domestic purposes.

Second environment includes establishments connected to a network not supplying domestic premises.

Drive of category C1: drive of rated voltage less than 1000 V and intended for use in the first environment.

Drive of category C2: drive of rated voltage less than 1000 V and intended to be installed and started up only by a professional when used in the first environment.

Note: A professional is a person or organization having necessary skills in installing and/or starting up power drive systems, including their EMC aspects.

Drive of category C3: drive of rated voltage less than 1000 V and intended for use in the second environment and not intended for use in the first environment.

Drive of category C4: drive of rated voltage equal to or above 1000 V, or rated current equal to or above 400 A, or intended for use in complex systems in the second environment.

■ Category C2

The drive complies with the standard with the following provisions:

1. The drive is equipped with EMC filter +E202/ARFI-10 and common mode filter (+E208).
2. The motor and control cables are selected as specified in the hardware manual.
3. The drive is installed according to the instructions given in the hardware manual.
4. Maximum motor cable length is 150 meters.

NOTICE The drive may cause radio interference. The user is required to take measures to prevent interference, in addition to the requirements for CE compliance listed above, if necessary.

Note: Do not install a drive equipped with EMC filter +E202/ARFI-10 on IT (ungrounded) systems. The supply network becomes connected to ground potential through the EMC filter capacitors which may cause danger or damage to the unit.

■ Category C3

The drive complies with the standard with the following provisions:

1. The drive is equipped with EMC filter (+E200 or +E201) and common mode filter (+E208).
2. The motor and control cables are selected as specified in the hardware manual.
3. The drive is installed according to the instructions given in the hardware manual.
4. Maximum motor cable length is 100 m (328 ft).
5. The value of parameter 97.01 is set to 2 kHz or less.

NOTICE A drive of category C3 is not intended to be used on a low-voltage public network which supplies domestic premises. Radio frequency interference is expected if the drive is used on such a network.

■ Category C4

The drive complies with the C4 category with these provisions:

1. It is made sure that no excessive emission is propagated to neighboring low-voltage networks. In some cases, the natural suppression in transformers and cables is sufficient. If in doubt, a supply transformer with static screening between the primary and secondary windings can be used.
-

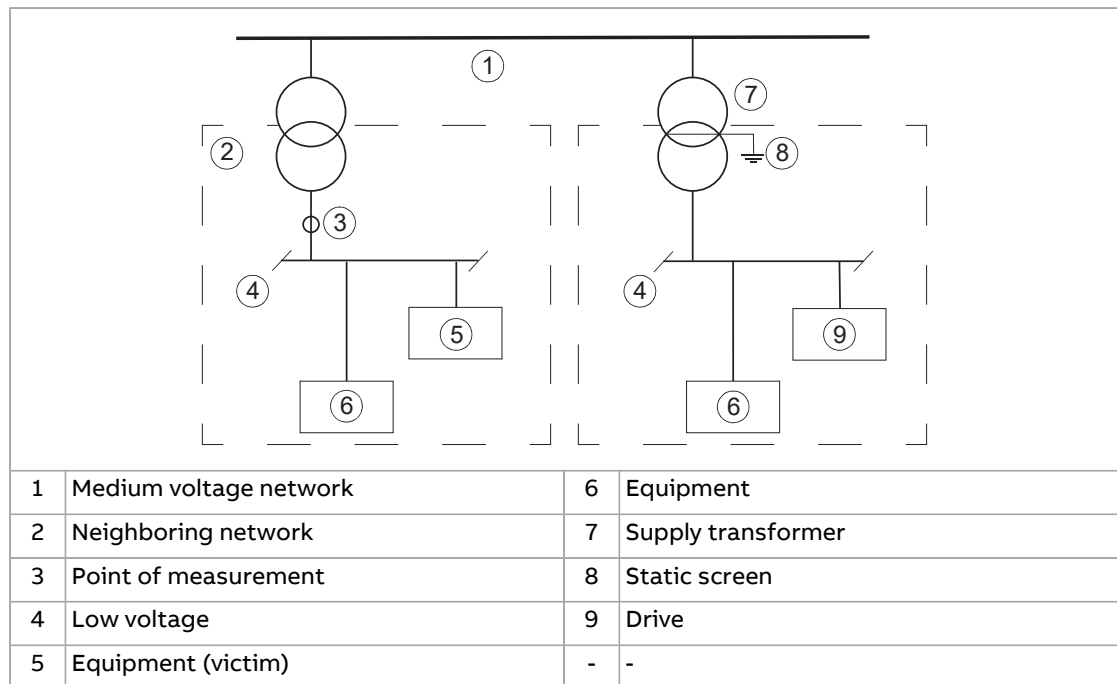

2. An EMC plan for preventing disturbances is drawn up for the installation. A template is available in [Technical guide No. 3 EMC compliant installation and configuration for a power drive system \(3AFE61348280 \[English\]\)](#).
3. The motor and control cables are selected, and routed according to the electrical planning guidelines of the drive. The EMC recommendations are obeyed.
4. The drive is installed according to its installation instructions. The EMC recommendations are obeyed.

NOTICE A drive of category C4 is not intended to be used on a low-voltage public network which supplies domestic premises. Radio frequency interference is expected if the drive is used on such a network.

UL checklist



⚠ WARNING Operation of this drive requires detailed installation and operation instructions provided in the hardware and software manuals. The manuals are provided in electronic format, in the drive package or on the Internet. Keep the manuals with the drive at all times. Hard copies of the manuals can be ordered through the manufacturer.

- Make sure that the drive type designation label includes the applicable marking.
 - **DANGER - Risk of electric shock.** After disconnecting the input power, always wait for 5 minutes to let the intermediate circuit capacitors discharge before you start working on the drive, motor or motor cable.
 - The drive is to be used in a heated, indoor controlled environment. The drive must be installed in clean air according to the enclosure classification. Cooling air must be clean, free from corrosive materials and electrically conductive dust.
 - The maximum surrounding air temperature is 40 °C at rated output current. The output current is derated for 40...55 °C.
 - The drive is suitable for use in a circuit capable of delivering not more than 100 kA rms symmetrical amperes, 600 V maximum when protected by the UL fuses given elsewhere in this chapter.
 - The cables located within the motor circuit must be rated for at least 75 °C in UL-compliant installations.
 - The input cable must be protected with fuses or circuit breakers. These protective devices provide branch circuit protection in accordance with the national regulations (National Electrical Code (NEC) or Canadian Electrical Code). Obey also any other applicable local or provincial codes.
-



⚠ WARNING The opening of the branch-circuit protective device may be an indication that a fault current has been interrupted. To reduce the risk of fire or electric shock, current-carrying parts and other components of the device should be examined and replaced if damaged.

- The integral solid state short circuit protection of the drive does not provide branch circuit protection. Branch circuit protection must be provided in accordance with the National Electrical Code and any additional local codes.
- The drive provides motor overload protection. The protection is not enabled when the drive leaves the ABB factory. For enabling the protection, see the firmware manual.
- The drive overvoltage category according to IEC 60664-1 is III.

Disclaimers

■ Generic disclaimer

The manufacturer shall have no obligation with respect to any product which (i) has been improperly repaired or altered; (ii) has been subjected to misuse, negligence or accident; (iii) has been used in a manner contrary to the manufacturer's instructions; or (iv) has failed as a result of ordinary wear and tear.

■ Cyber security disclaimer

This product is designed to be connected to and to communicate information and data via a network interface. It is Customer's sole responsibility to provide and continuously ensure a secure connection between the product and Customer network or any other network (as the case may be). Customer shall establish and maintain any appropriate measures (such as but not limited to the installation of firewalls, application of authentication measures, encryption of data, installation of anti-virus programs, etc.) to protect the product, the network, its system and the interface against any kind of security breaches, unauthorized access, interference, intrusion, leakage and/or theft of data or information.

ABB and its affiliates are not liable for damages and/or losses related to such security breaches, any unauthorized access, interference, intrusion, leakage and/or theft of data or information.

Declarations of conformity



[Link to Declaration of conformity according to EU Machinery Directive 2006/42/EU \(3AXD10000099646\)](#)



[Link to Declaration of conformity according to UK Supply of Machinery \(Safety\) Regulations 2008 \(3AXD10001329538\)](#)



[Link to Declaration of China RoHS II Conformity \(3AXD10001497397\)](#)



Dimension drawings

Contents of this chapter

This chapter contains dimension drawings of the drive modules with optional parts for Rittal VX25 enclosure assembly.

R10 – Standard configuration

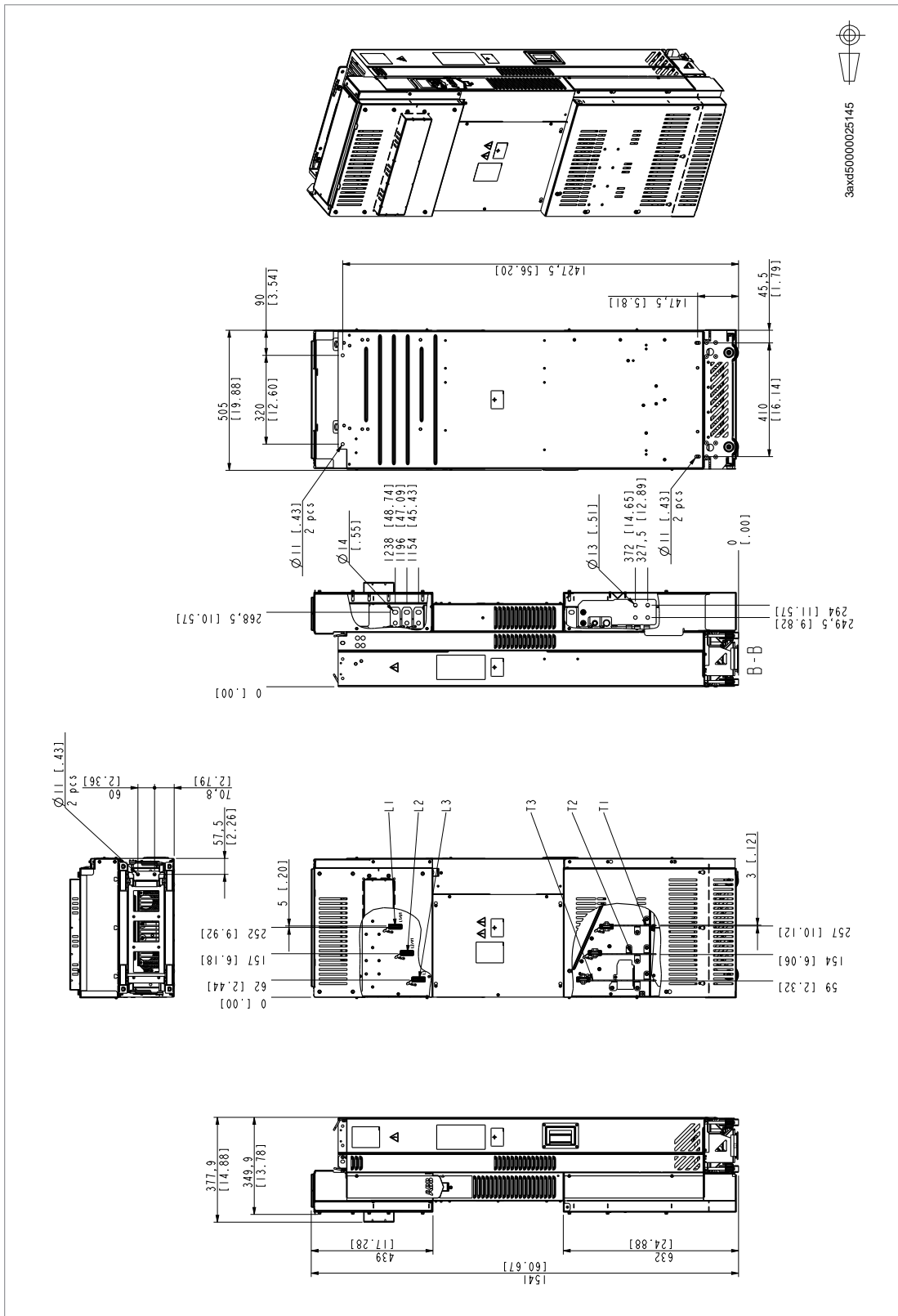

R10 with options +E208+H370+J414+P905

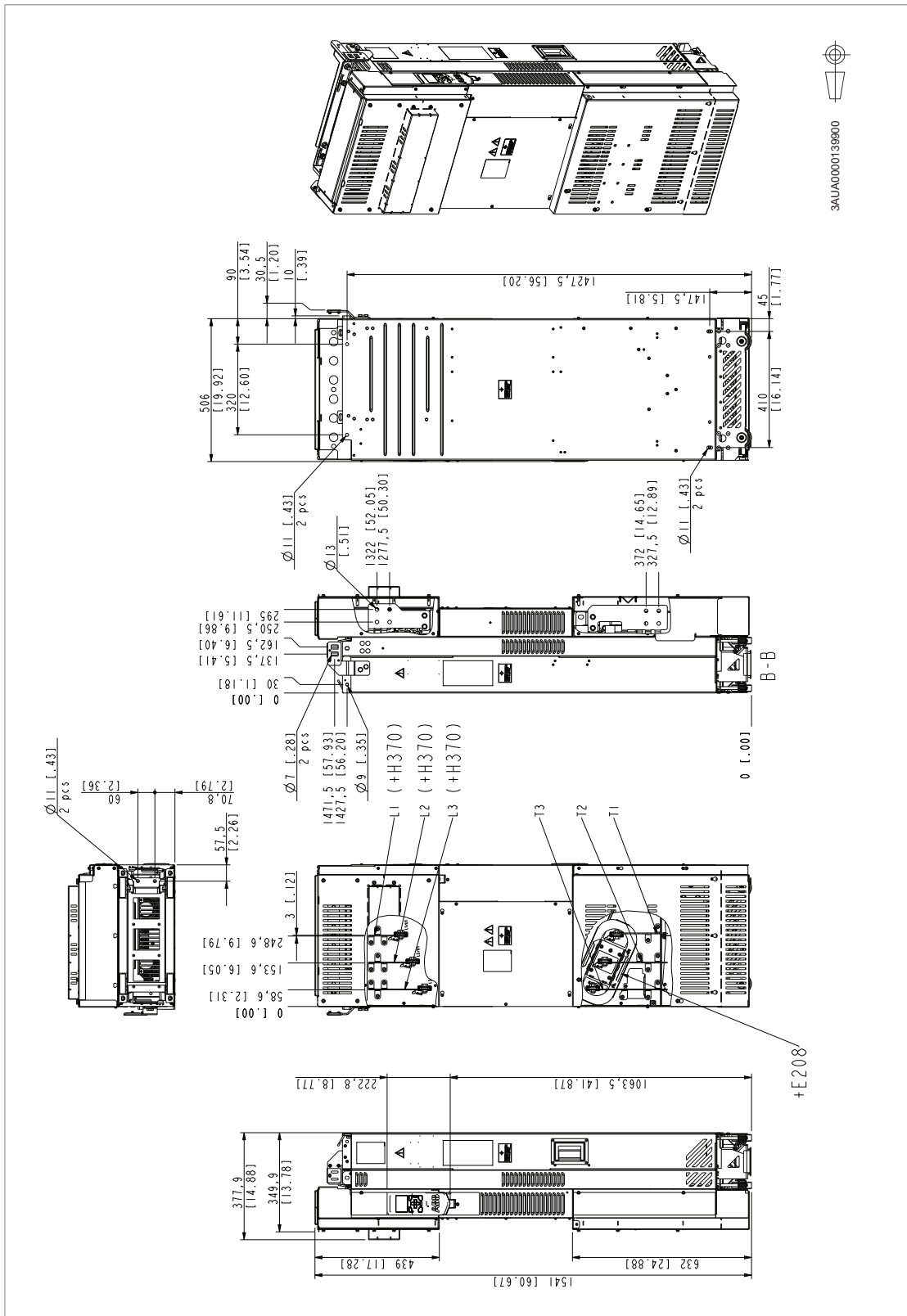

R10 with options +OB051+C173+E208+H356+OH354+OH371

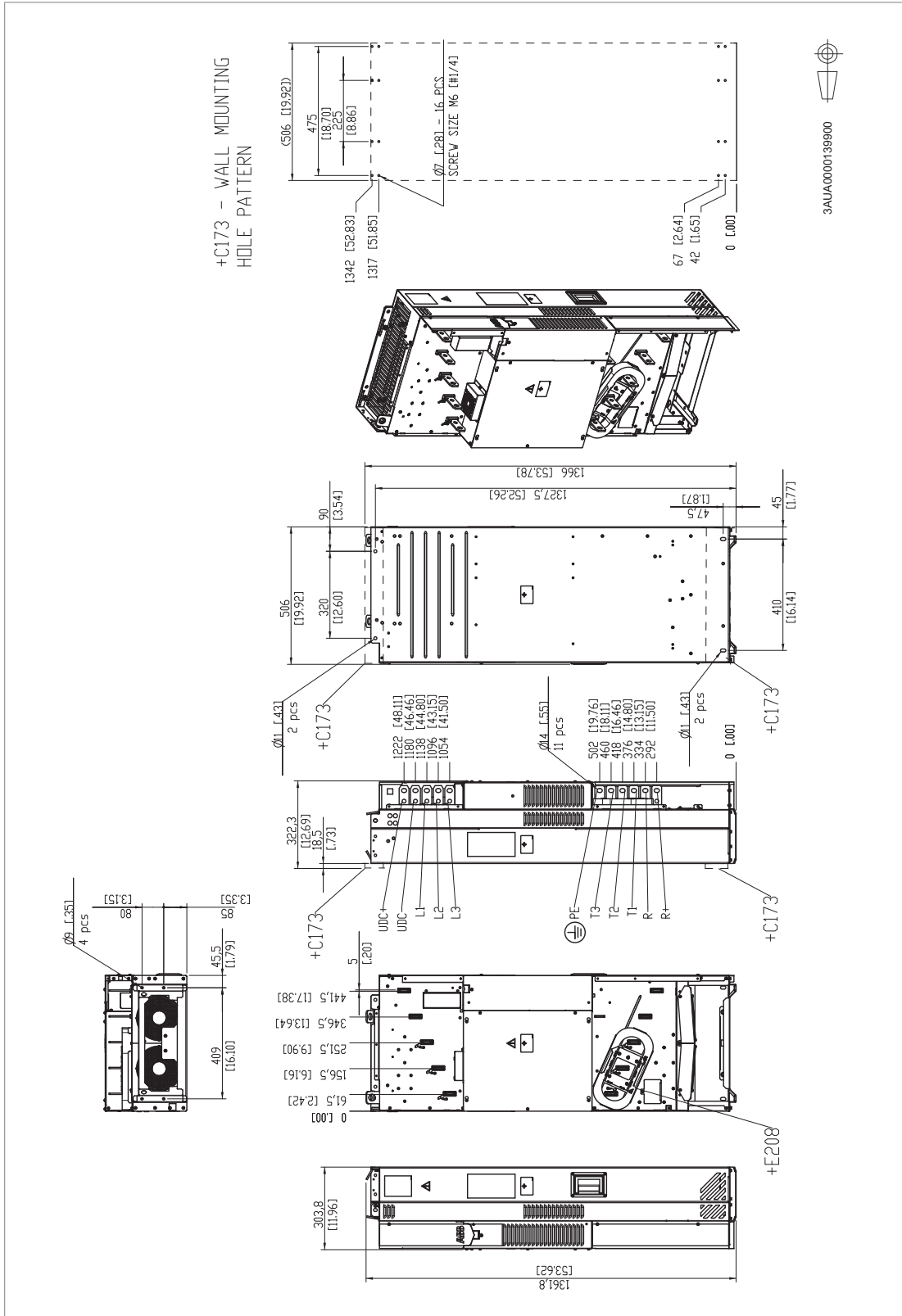

R10 with options +0B051+E208+H356+0H371

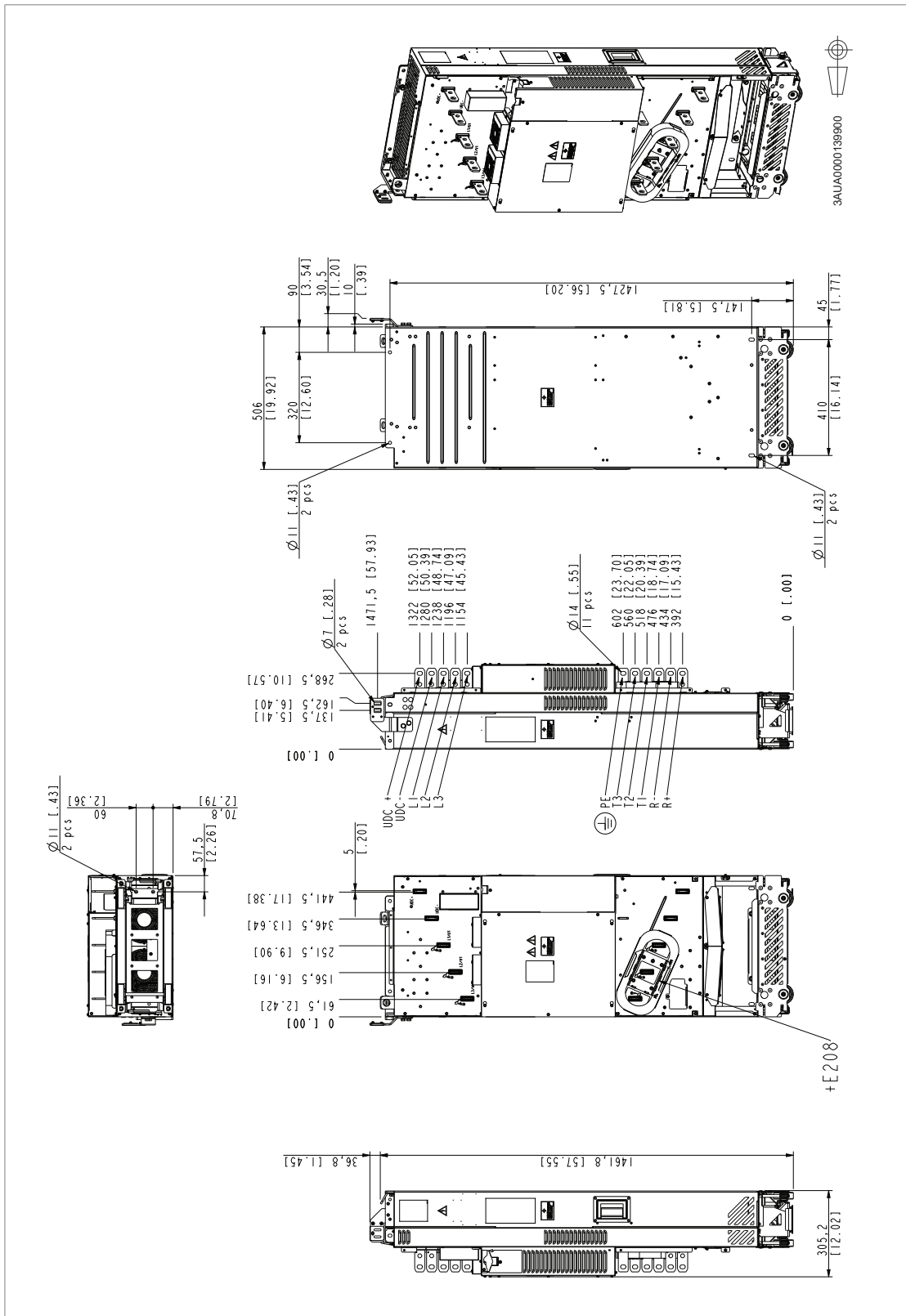

R10 with options +E208+H356+H381+J414+P905

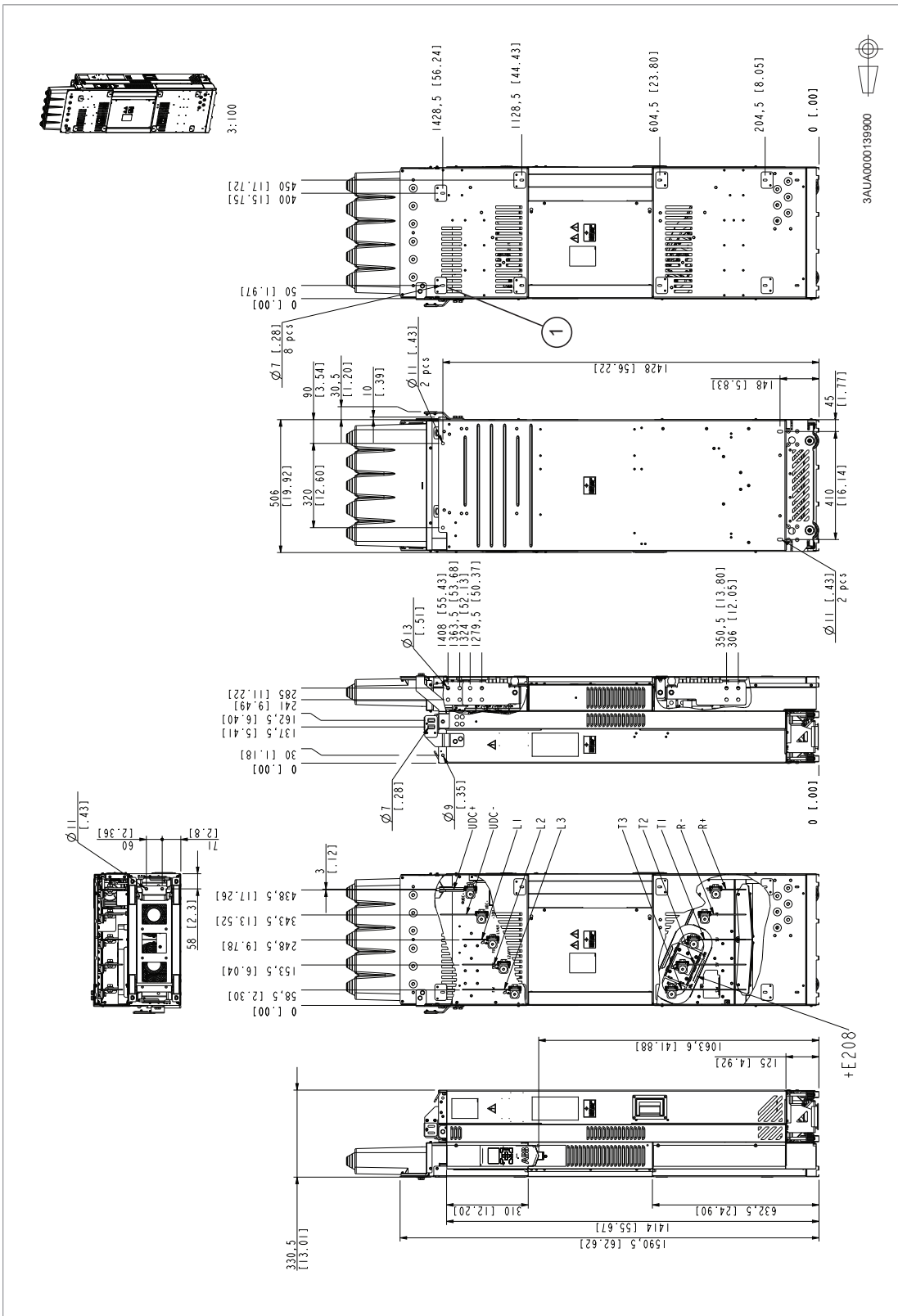

1) Shim plate (3AXD50000546336) for Rittal VX25 enclosure. There are 8 shim plates attached to the drive module. If the drive module is installed into a Rittal TS8 enclosure, remove the shim plates.

R10 – Cabling panels (+H381) installed into a Rittal VX25 enclosure

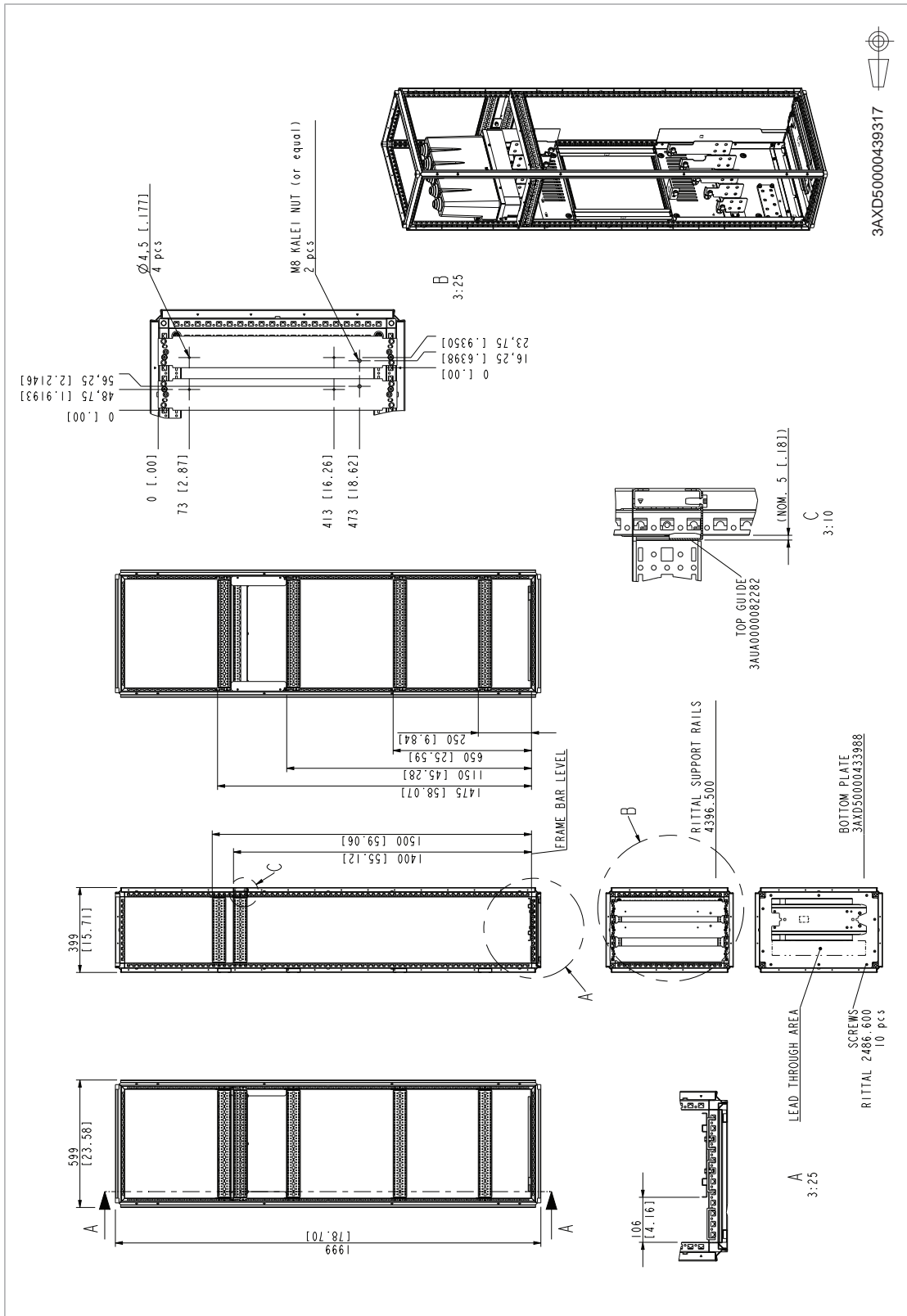

R10 with options +E208+H370+H391+0J400

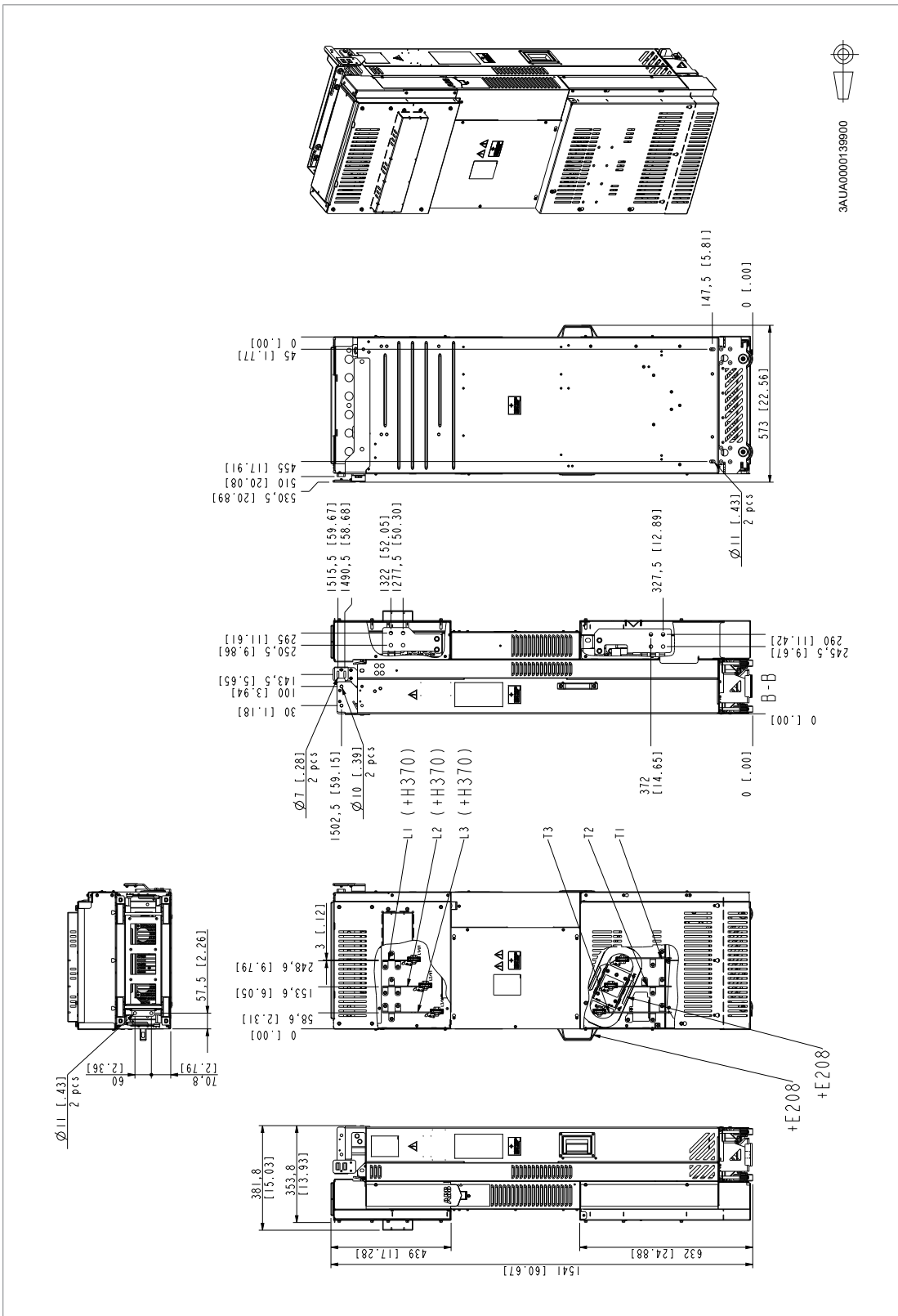

R11 – Standard configuration

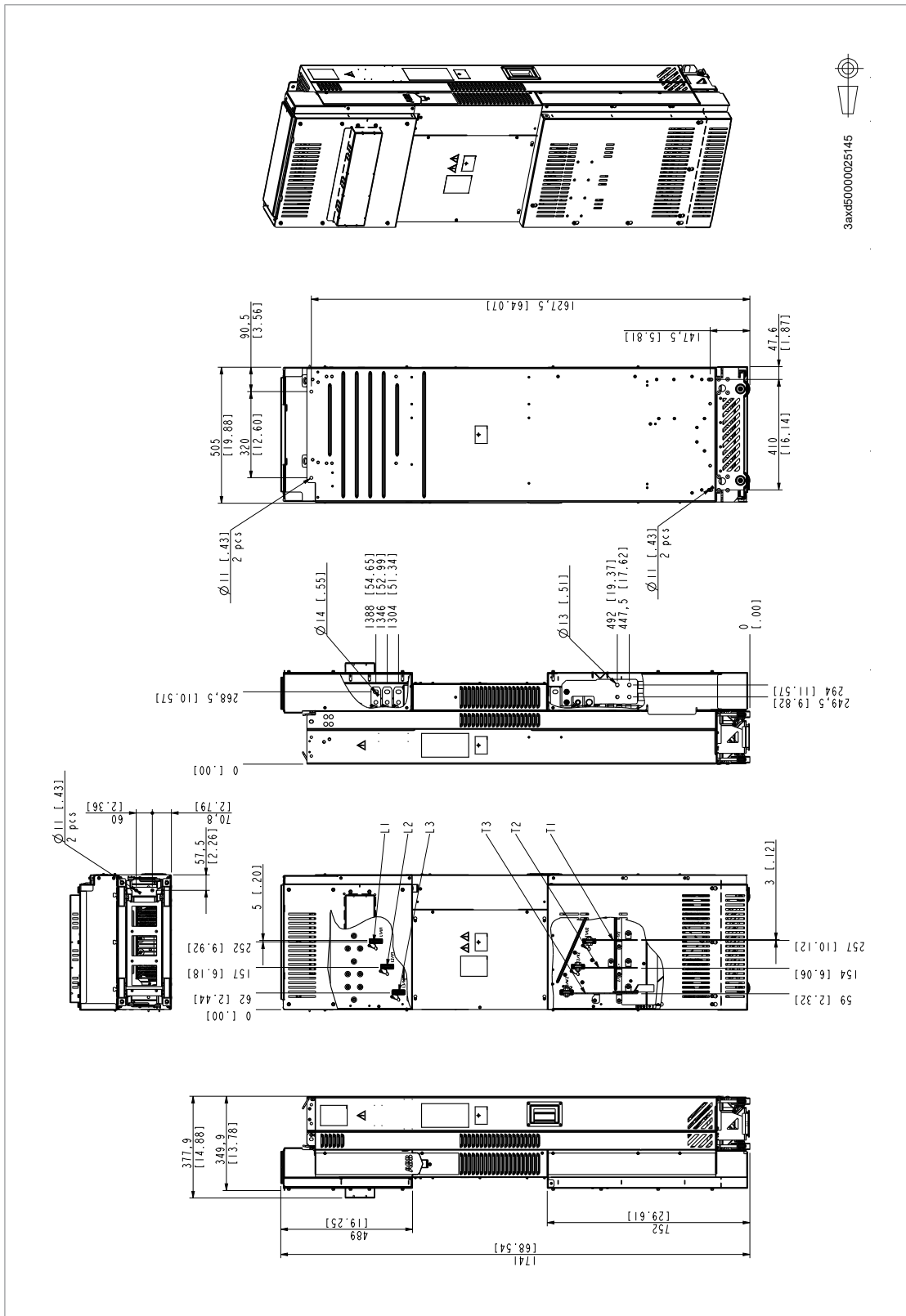

R11 with options +E208+H356+H381+J414+P905

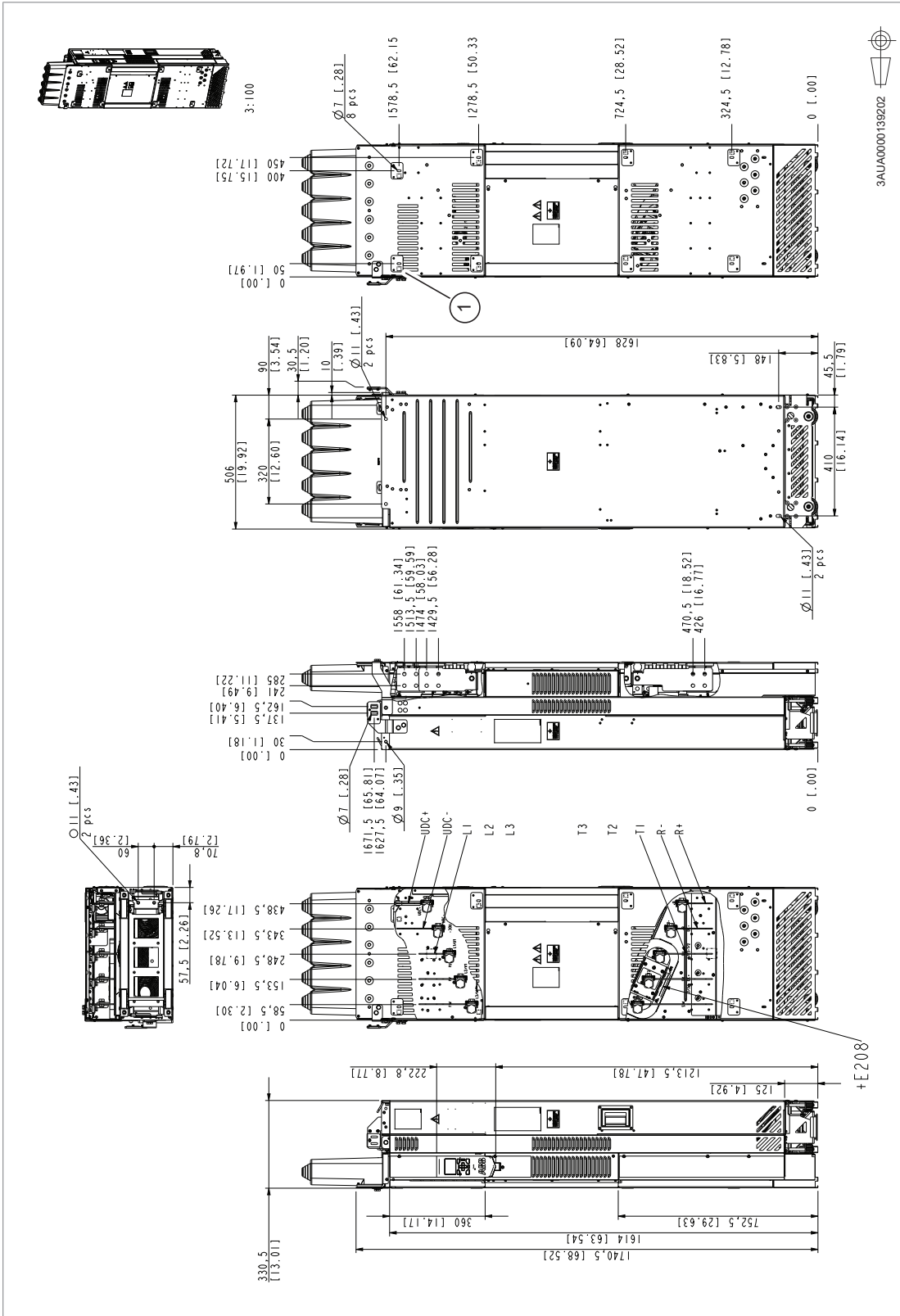

1) Shim plate (3AXD50000546336) for Rittal VX25 enclosure. There are 8 shim plates attached to the drive module. If the drive module is installed into a Rittal TS8 enclosure, remove the shim plates.

R11 with options +0B051+C173+E208+H356+0H354+0H371

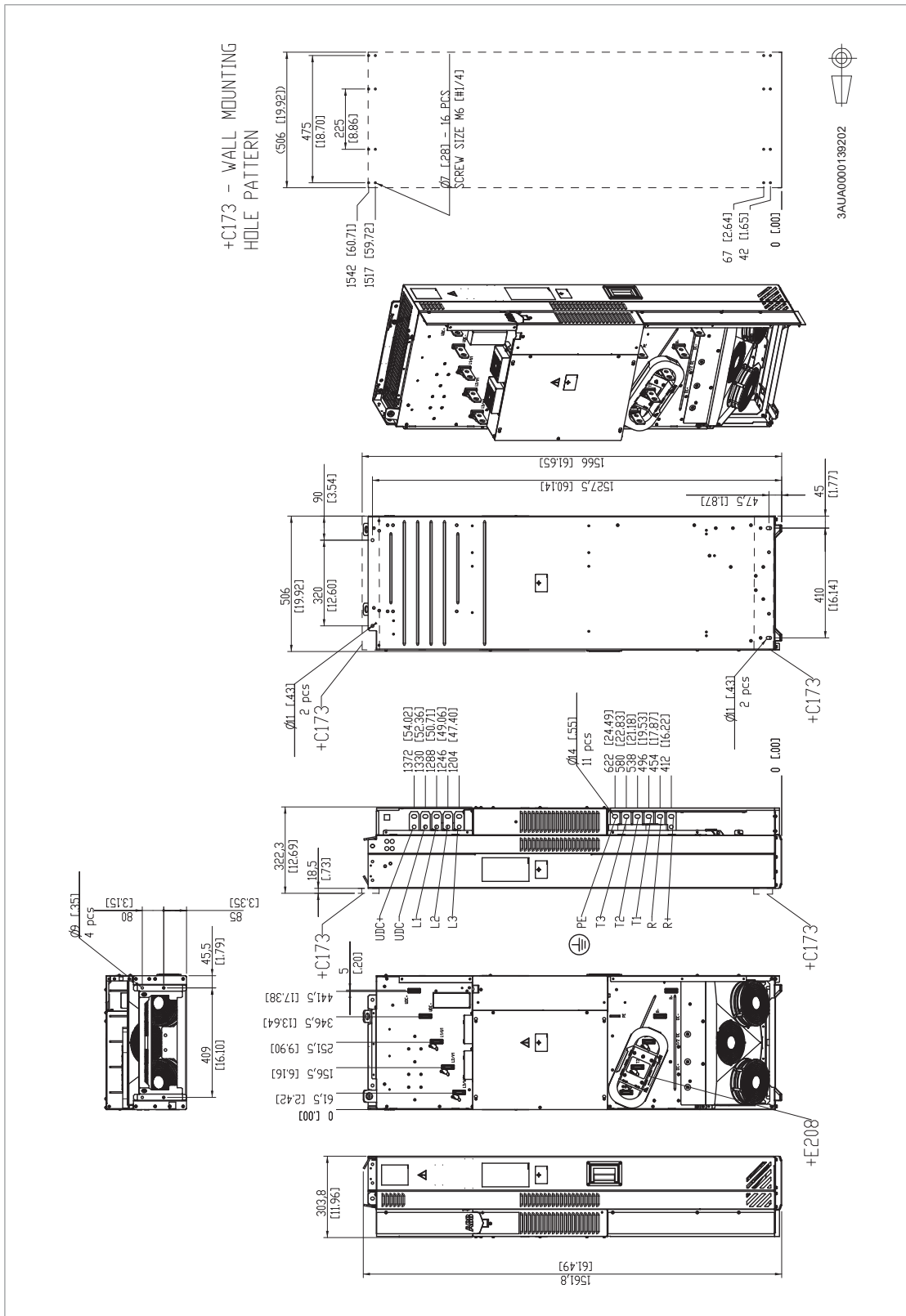

R11 – Cabling panels (+H381) installed into a Rittal VX25 enclosure

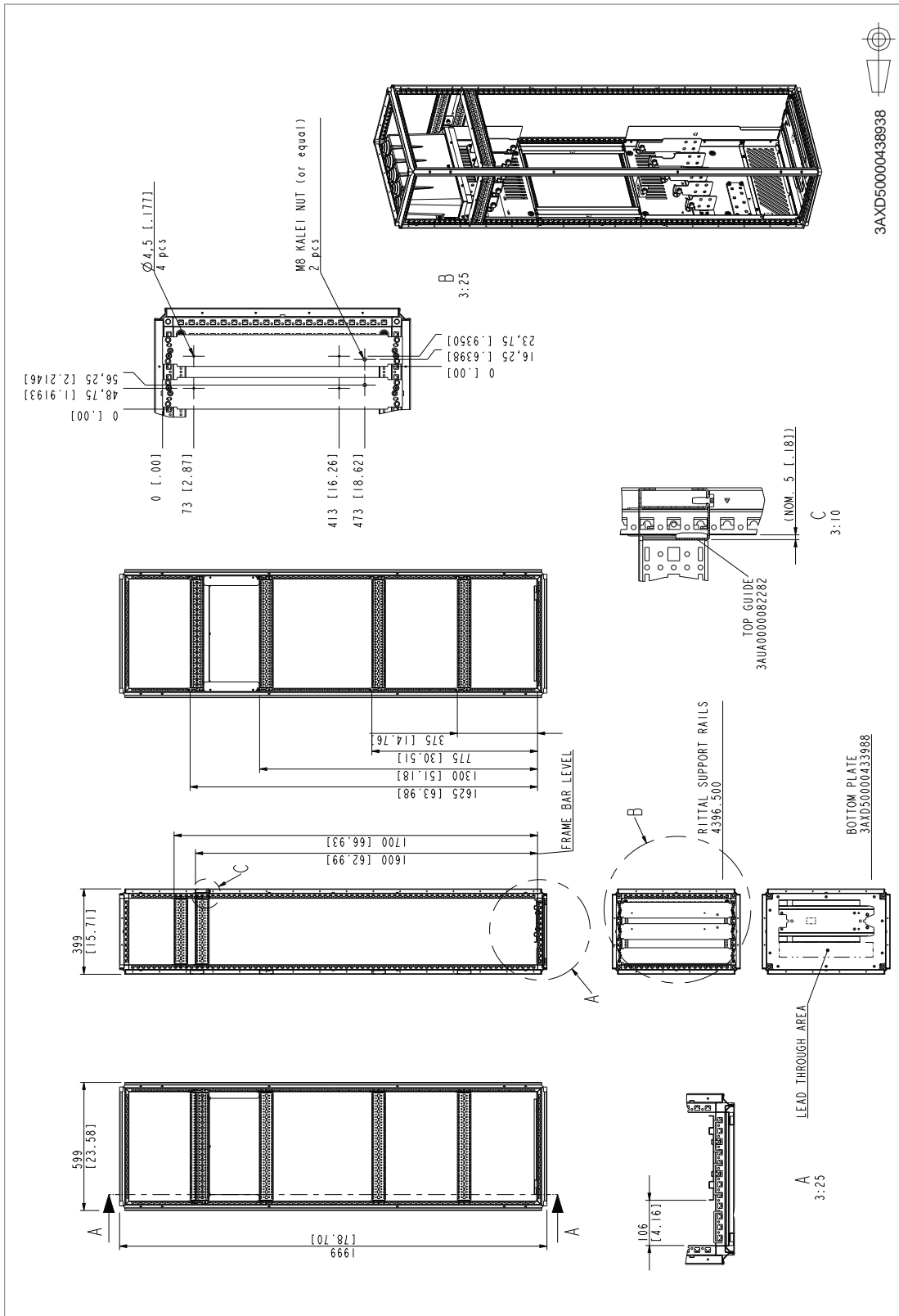

Bottom plate for option +H381 in Rittal VX25 400 mm wide enclosure installation

Note: The bottom plate is not an ABB part.

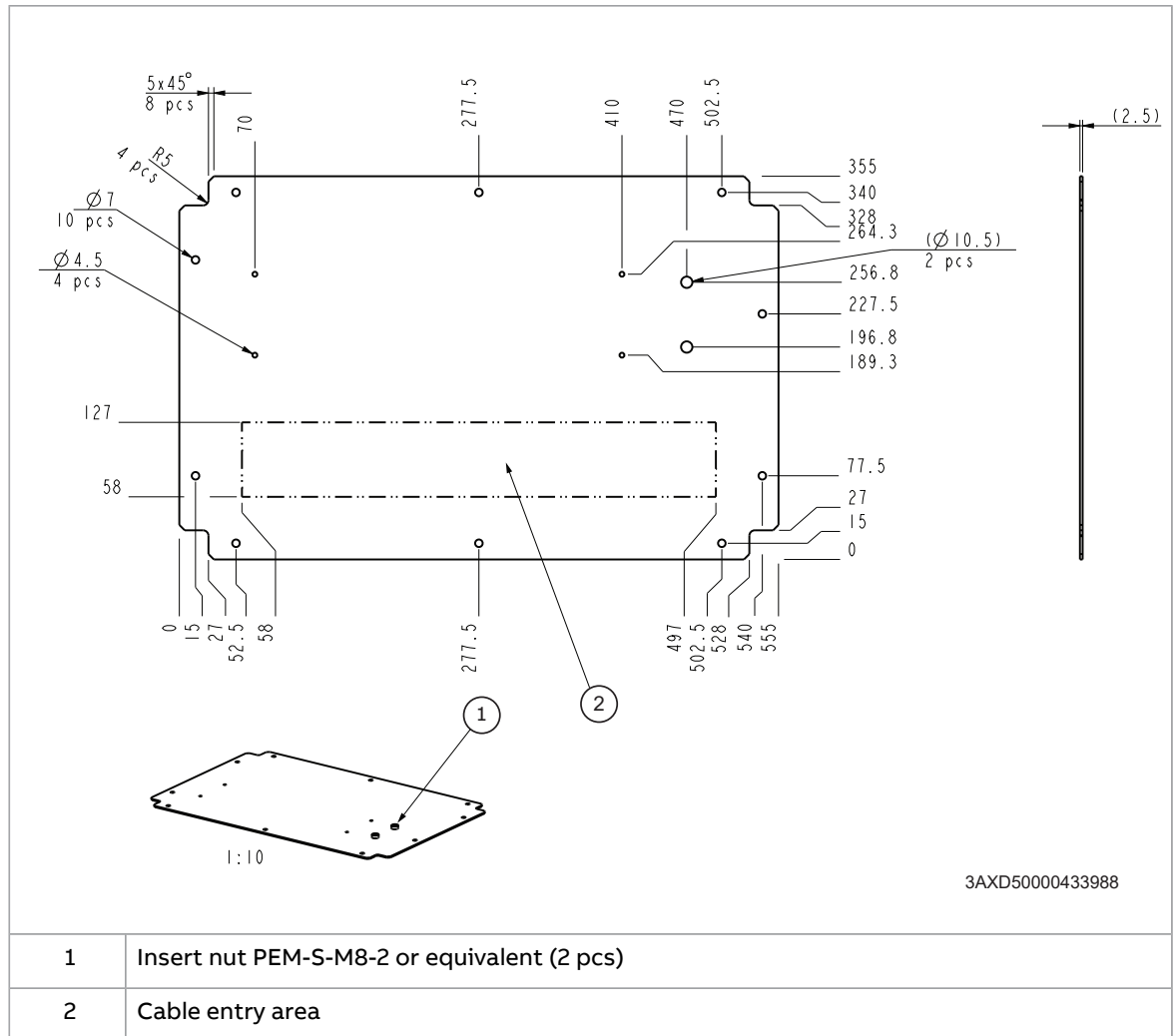

Frame R11 with options +E208+H370+H391+0J400

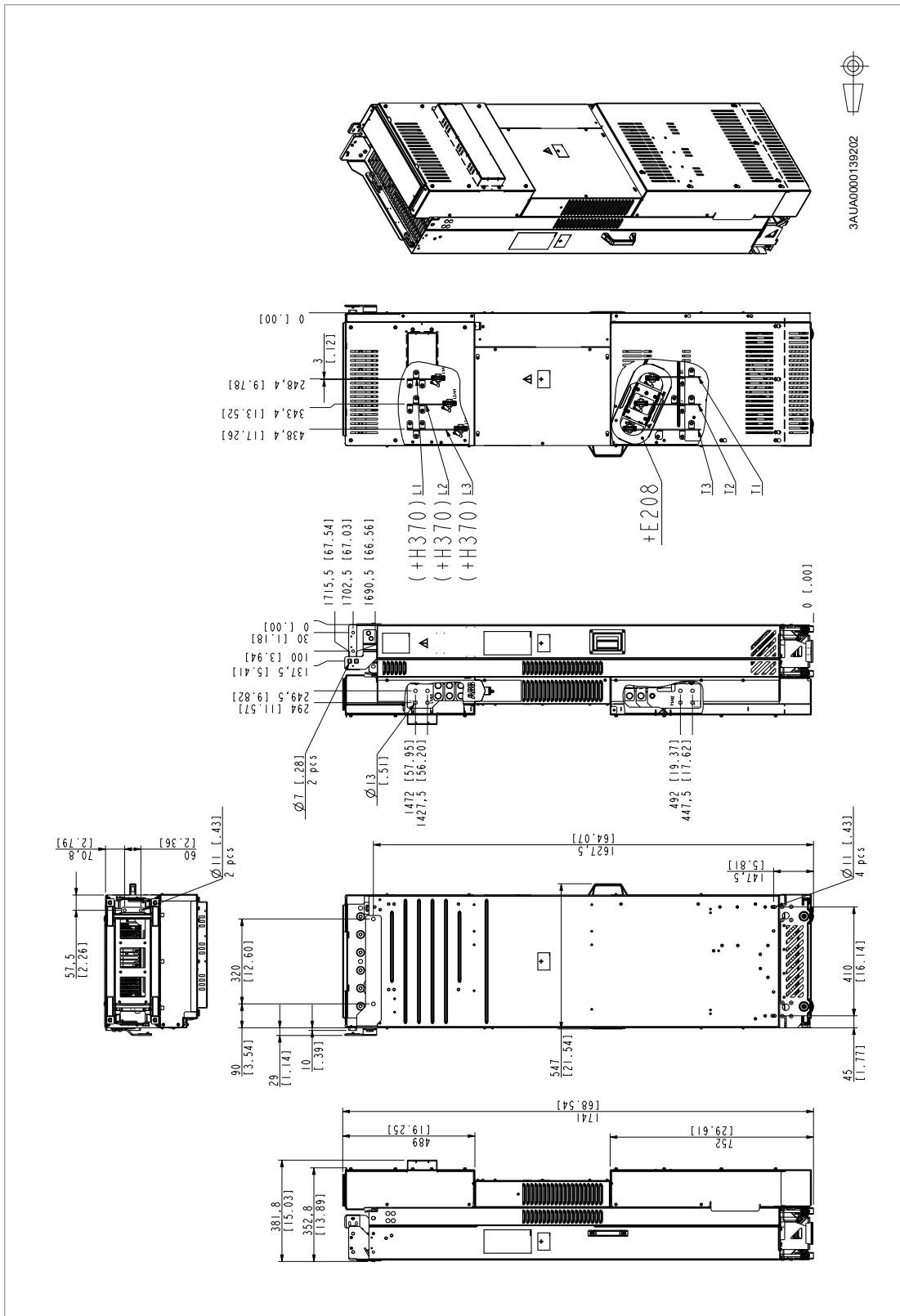

Air baffles for the standard drive module and option +C173

This drawing shows the dimensions of the hole in the air baffle around the standard drive module and flat mounting option +C173. The drawing also shows the correct vertical location area of the air baffle as measured from the top grating.

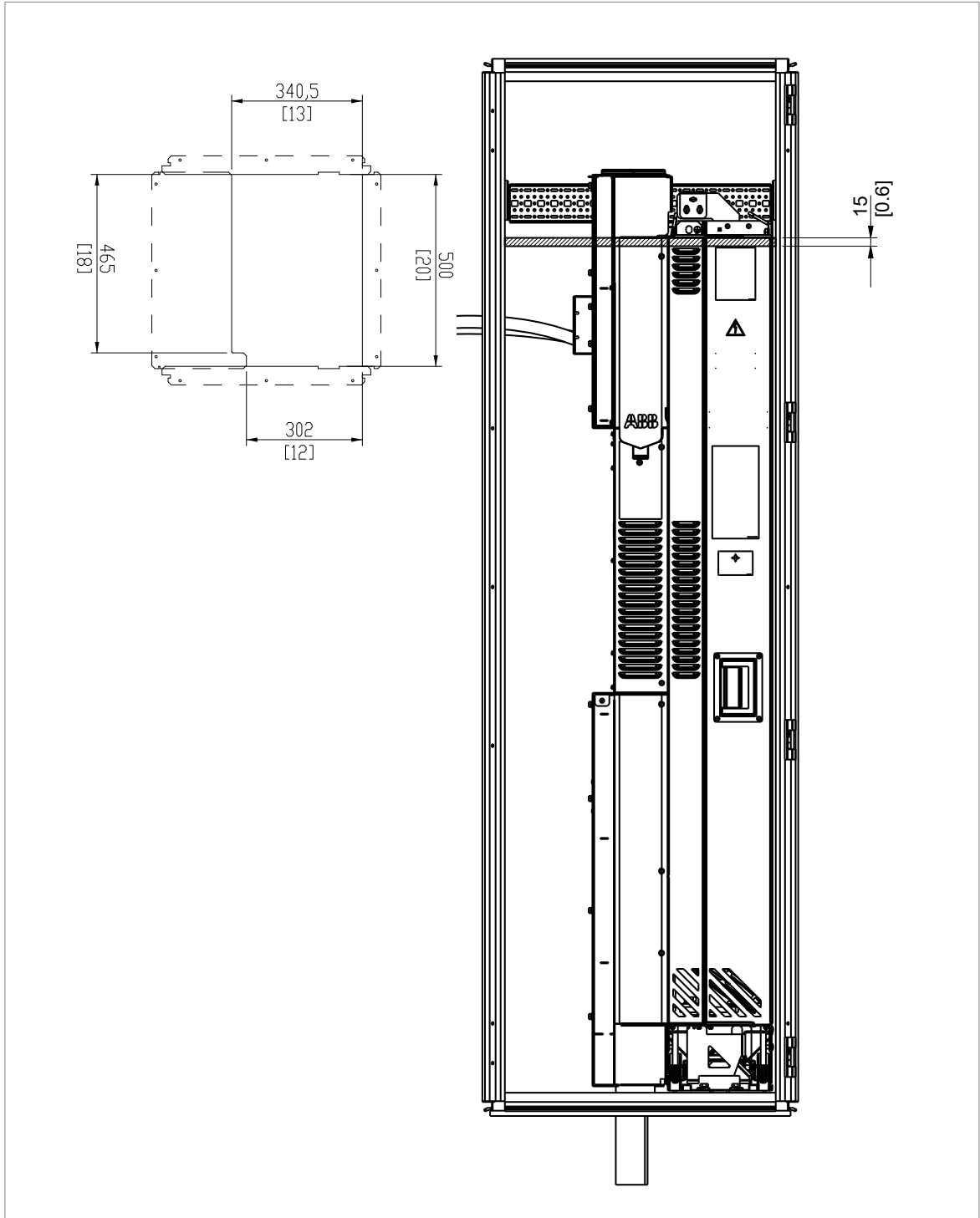

Air baffles for option +H381 in Rittal VX25 400 mm wide enclosure installation

Note: These air baffles are not ABB parts.

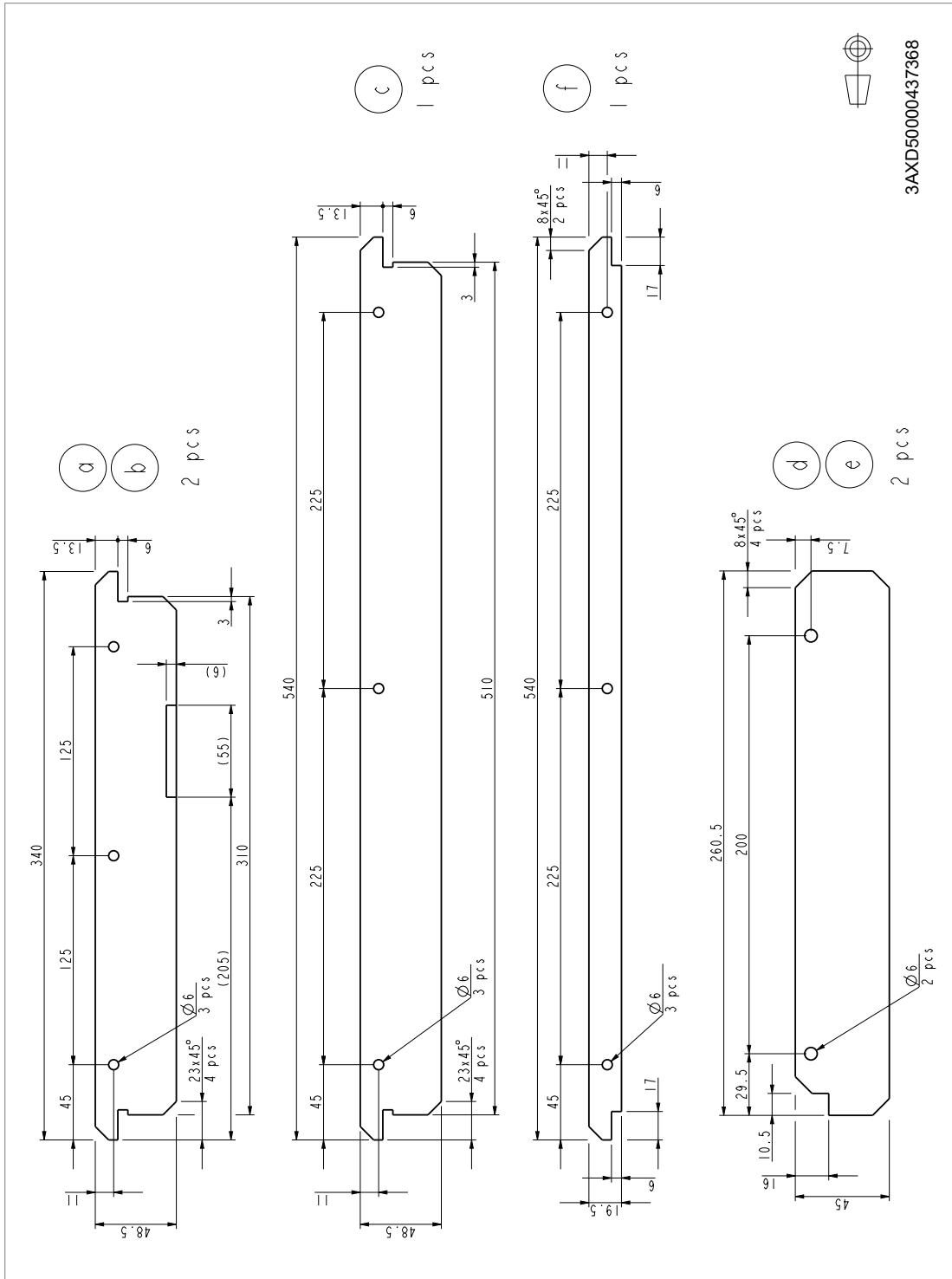

■ Material of the air baffles

0.75 mm polycarbonate (PC) film LEXAN® FR60 (GE) with UL94 V-0 listing, UV stability. Unmarked bend radii 0.6 mm.

External control unit

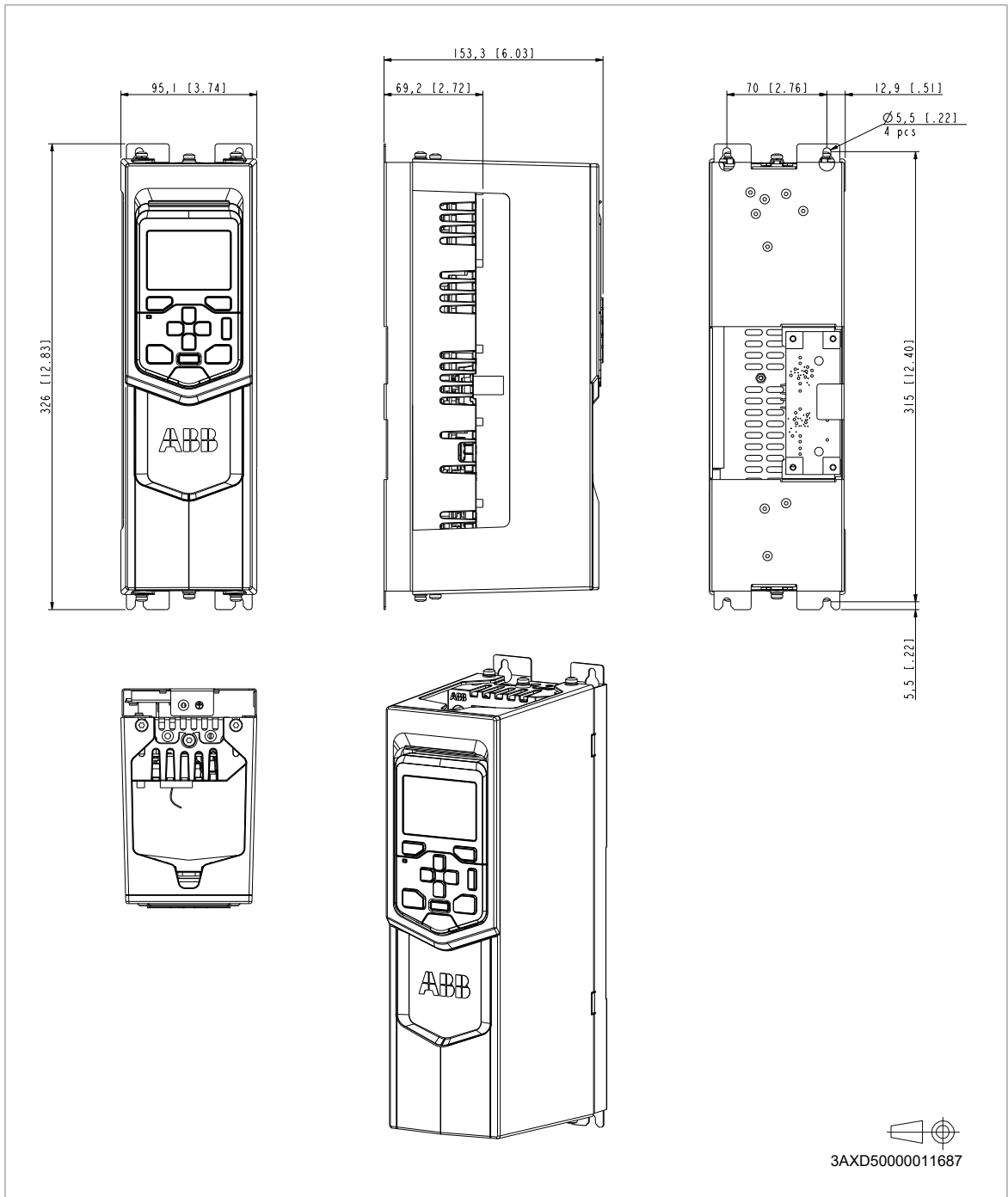



18

Example circuit diagram

Contents of this chapter

This chapter shows an example circuit diagram for a cabinet-installed drive module.

Example circuit diagram

This diagram is an example for the main wiring of a drive cabinet. Note that the diagram includes components which are not included in a basic delivery.

232 Example circuit diagram

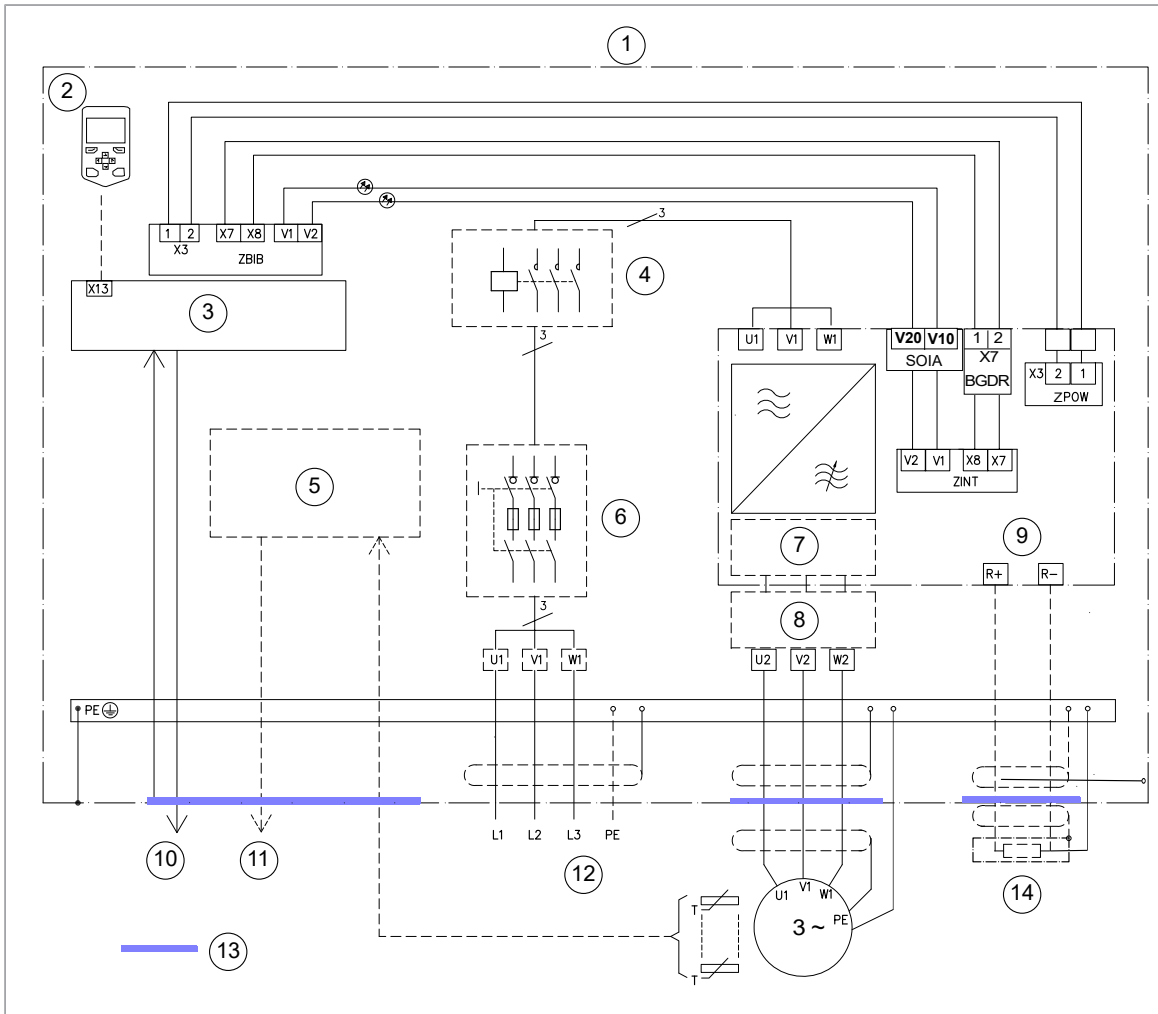

1	Cabinet
2	Control panel
3	ZCU control unit
4	Main contactor ¹⁾
5	Motor temperature supervision ²⁾
6	Switch fuse disconnecter ¹⁾
7	Common mode filter ³⁾
8	du/dt filter or sine filter ²⁾
9	Drive module
10	Input and output signals
11	Alarm
12	Supply
13	360 degree grounding recommended
14	Brake resistor ²⁾

¹⁾ Must be acquired by the customer.

²⁾ Optional (can be installed by the customer).

³⁾ Optional (can be selected with an option code).

19

The Safe torque off function

Contents of this chapter

This chapter describes the Safe torque off (STO) function of the drive and gives instructions for its use.

Description



▲WARNING In case of parallel-connected drives or dual-winding motors, the STO must be activated on each drive to remove the torque from the motor.

The Safe torque off function can be used, for example, as the final actuator device of safety circuits (such as an emergency stop circuit) that stop the drive in case of danger. Another typical application is a prevention of unexpected start-up function that enables short-time maintenance operations like cleaning or work on non-electrical parts of the machinery without switching off the power supply to the drive.

When activated, the Safe torque off function disables the control voltage for the power semiconductors of the drive output stage, thus preventing the drive from generating the torque required to rotate the motor. If the motor is running when Safe torque off is activated, it coasts to a stop.

The Safe torque off function has a redundant architecture, that is, both channels must be used in the safety function implementation. The safety data given in this manual is calculated for redundant use, and does not apply if both channels are not used.

The Safe torque off function complies with these standards:

Standard	Name
IEC 60204-1:2021 EN 60204-1:2018	Safety of machinery – Electrical equipment of machines – Part 1: General requirements

Standard	Name
IEC 61000-6-7:2014	Electromagnetic compatibility (EMC) – Part 6-7: Generic standards – Immunity requirements for equipment intended to perform functions in a safety-related system (functional safety) in industrial locations
IEC 61326-3-1:2017	Electrical equipment for measurement, control and laboratory use – EMC requirements – Part 3-1: Immunity requirements for safety-related systems and for equipment intended to perform safety-related functions (functional safety) – General industrial applications
IEC 61508-1:2010	Functional safety of electrical/electronic/programmable electronic safety-related systems – Part 1: General requirements
IEC 61508-2:2010	Functional safety of electrical/electronic/programmable electronic safety-related systems – Part 2: Requirements for electrical/electronic/programmable electronic safety-related systems
IEC 61511-1:2017	Functional safety – Safety instrumented systems for the process industry sector
IEC 61800-5-2:2016 EN 61800-5-2:2007	Adjustable speed electrical power drive systems – Part 5-2: Safety requirements – Functional
EN IEC 62061:2021	Safety of machinery – Functional safety of safety-related control systems
EN ISO 13849-1:2015	Safety of machinery – Safety-related parts of control systems – Part 1: General principles for design
EN ISO 13849-2:2012	Safety of machinery – Safety-related parts of control systems – Part 2: Validation

The function also corresponds to Prevention of unexpected start-up as specified by EN ISO 14118:2018 (ISO 14118:2017), and Uncontrolled stop (stop category 0) as specified in EN/IEC 60204-1.

■ Compliance with the European Machinery Directive and the UK Supply of Machinery (Safety) Regulations

Refer to the technical data.

Wiring

The connection diagrams in this section are applicable to drives with ZCU control unit. For the connection diagrams of the UCU-20 control unit (option +V998), refer to [UCU-20 control unit hardware manual \(3AXD50001079246 \[English\]\)](#).

For the electrical specifications of the STO connection, see the technical data of the control unit.

■ Activation switch

In the wiring diagrams, the activation switch has the designation [K]. This represents a component such as a manually operated switch, an emergency stop push button switch, or the contacts of a safety relay or safety PLC.

- In case a manually operated activation switch is used, the switch must be of a type that can be locked out to the open position.
- The contacts of the switch or relay must open/close within 200 ms of each other.
- Drives with ZCU control unit: An FSO, FSPS, FSCS, or FPTC module can also be used. For more information, see the module documentation.
- Drives with UCU-20 control unit: An FSPS module can also be used. For more information, see the module documentation.

■ Cable types and lengths

- ABB recommends double-shielded twisted-pair cable.
- Maximum cable lengths:
 - 300 m (1000 ft) between activation switch [K] and drive control unit
 - 60 m (200 ft) between multiple drives
 - 60 m (200 ft) between external power supply and first control unit

Note: A short-circuit in the wiring between the switch and an STO terminal causes a dangerous fault. Therefore, it is recommended to use a safety relay (including wiring diagnostics) or a wiring method (shield grounding, channel separation) which reduces or eliminates the risk caused by the short-circuit.

Note: The voltage at the STO input terminals of the control unit must be at least 17 V DC for ZCU-14 control unit and 15 V DC for UCU-20 control unit to be interpreted as “1”.

The pulse tolerance of the input channels is 1 ms.

■ Grounding of protective shields

- Ground the shield in the cabling between the activation switch and the control unit at the control unit only.
 - Ground the shield in the cabling between two control units at one control unit only.
-

■ **Single drive (internal power supply)**

Dual-channel connection

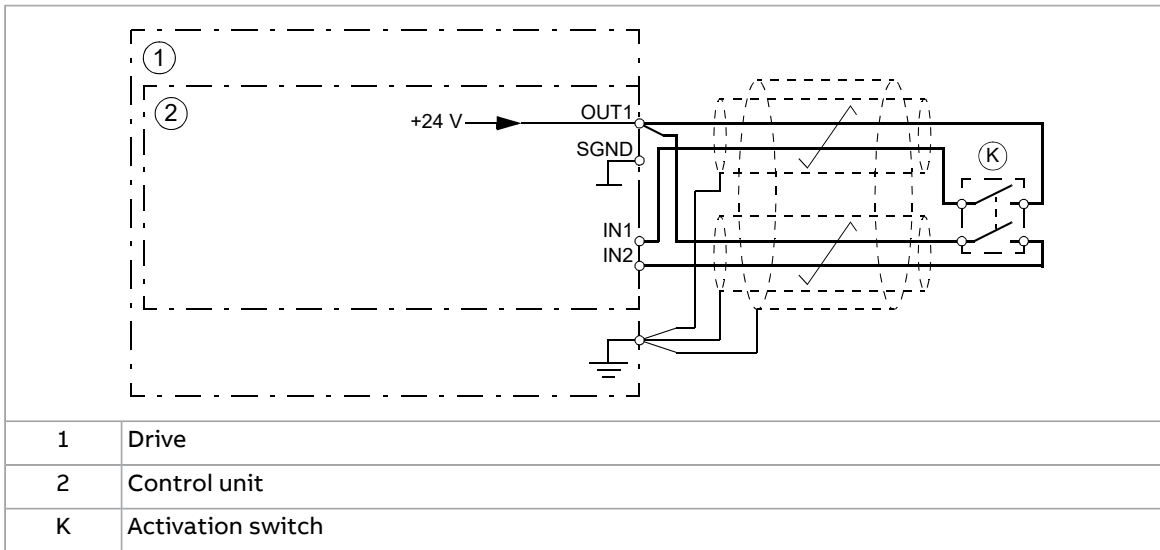

Single-channel connection

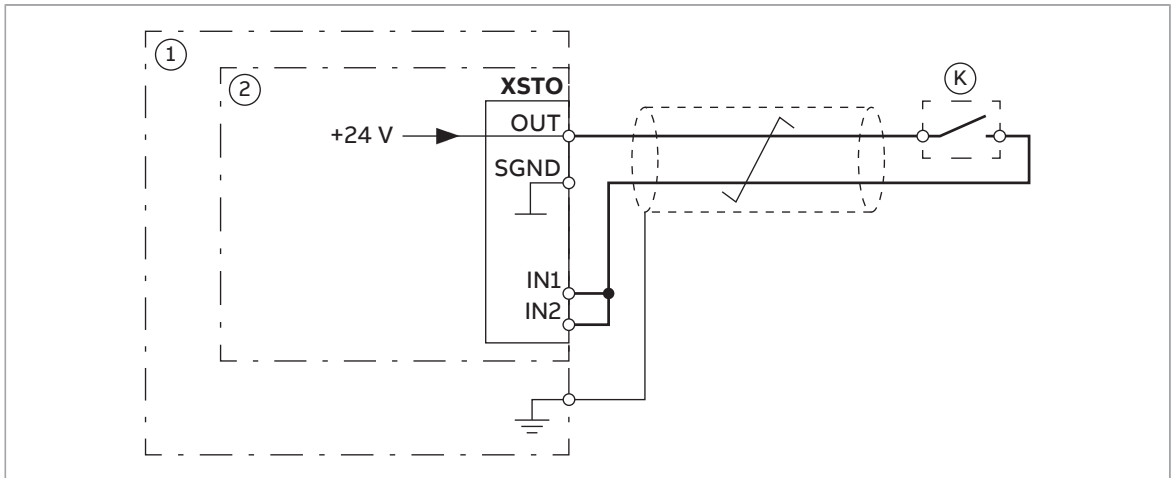

Note:

- Both STO inputs (IN1, IN2) must be connected to the activation switch. Otherwise, no SIL/PL classification is given.
- Pay special attention to avoiding any potential failure modes for the wiring. For example, use shielded cable. For measures for fault exclusion of wiring, see eg. EN ISO 13849-2:2012, table D.4.

1	Drive
2	Control unit
K	Activation switch
	Note: A single-channel activation switch can limit the SIL/PL capability of the safety function to a lower level than the SIL/PL capability of the STO function of the drive.

■ **Multiple drives**

Internal power supply

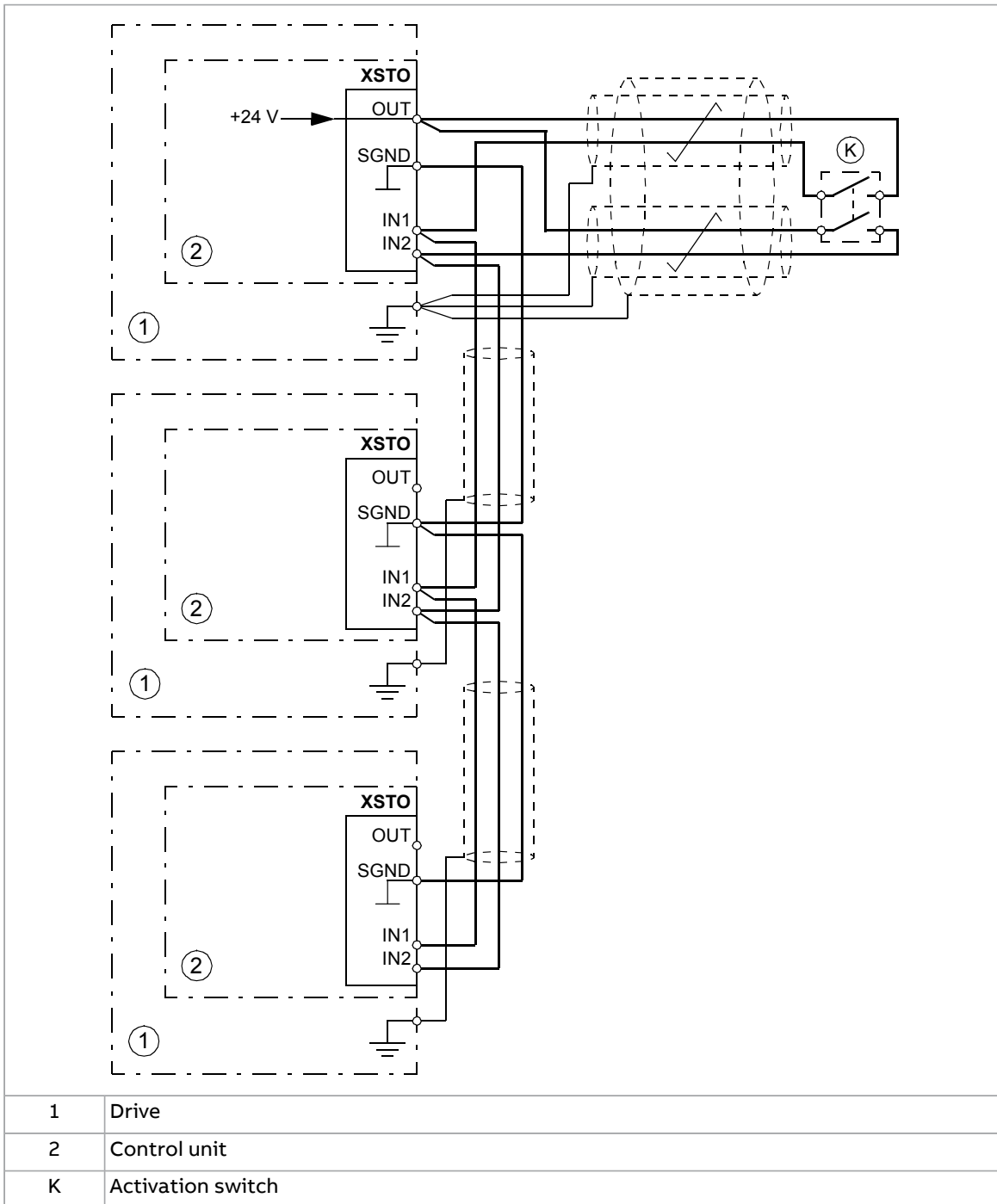

External power supply

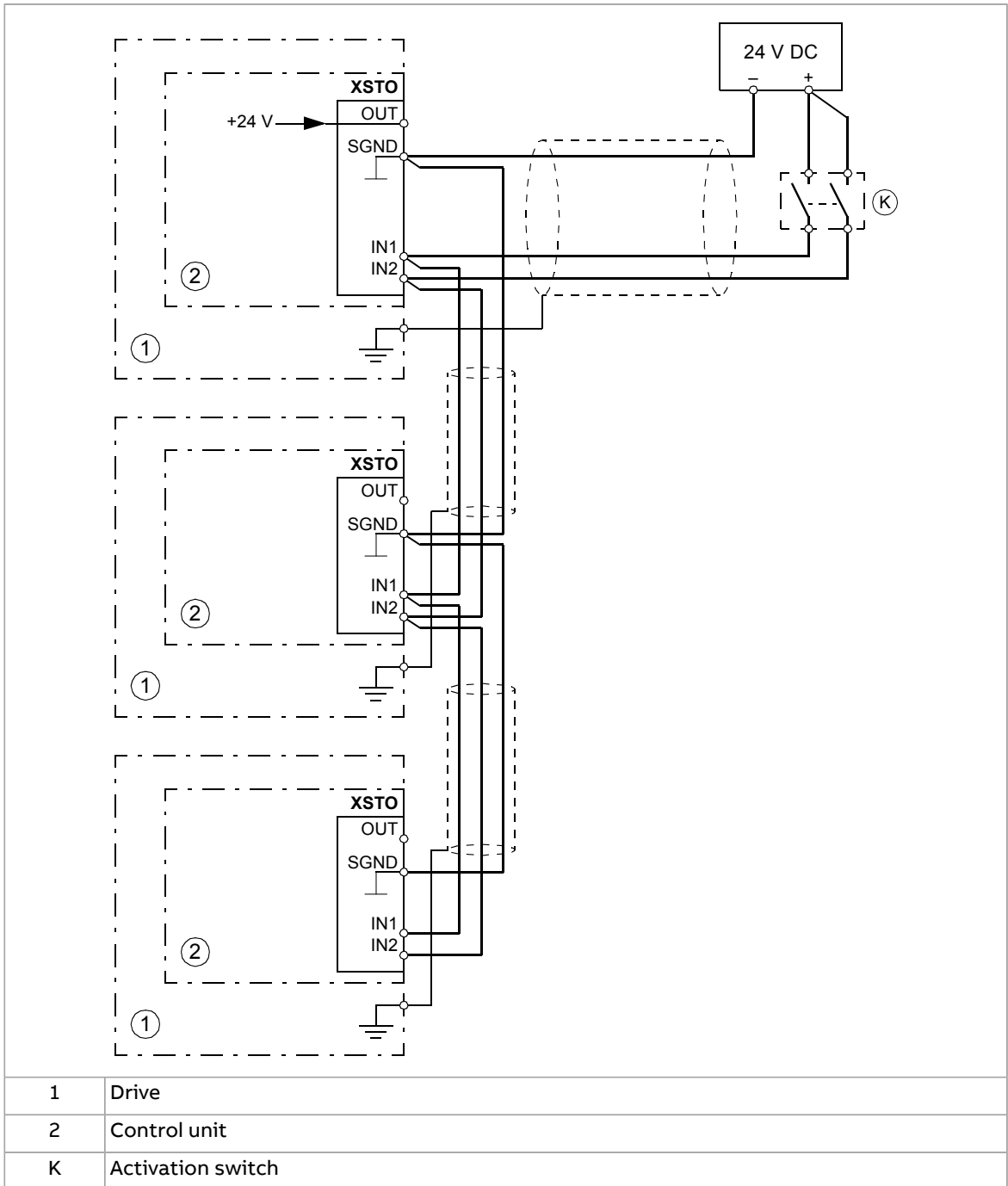

Operation principle

1. The Safe torque off activates (the activation switch is opened, or safety PLC logic output value is 0, or safety relay contacts open).
2. The STO inputs of the drive control unit de-energize.
3. The control unit cuts off the control voltage from the output IGBTs.
4. The control program generates an indication as defined by parameter 31.22 (refer the firmware manual of the drive).

The parameter selects which indications are given when one or both STO signals are switched off or lost. The indications also depend on whether the drive is running or stopped when this occurs.

Note: This parameter does not affect the operation of the STO function itself. The STO function will operate regardless of the setting of this parameter: a running drive will stop upon removal of one or both STO signals, and will not start until both STO signals are restored and all faults reset.

Note: The loss of only one STO signal always generates a fault as it is interpreted as a malfunction of STO hardware or wiring.

5. The motor coasts to a stop (if running). The drive cannot restart while the activation switch or safety relay contacts are open. After the contacts close, a reset may be needed (depending on the setting of parameter 31.22). A new start command is required to start the drive.
-

Start-up including validation test

To ensure the safe operation of a safety function, validation is required. The final assembler of the machine must validate the function by performing a validation test. The test must be performed

1. at initial start-up of the safety function
2. after any changes related to the safety function (circuit boards, wiring, components, settings, replacement of inverter module, etc.)
3. after any maintenance work related to the safety function
4. after a drive firmware update
5. at the proof test of the safety function.

■ Competence

The validation test of the safety function must be carried out by a competent person with adequate expertise and knowledge of the safety function as well as functional safety, as required by IEC 61508-1 clause 6. The test procedures and report must be documented and signed by this person.

■ Validation test reports

Signed validation test reports must be stored in the logbook of the machine. The report shall include documentation of start-up activities and test results, references to failure reports and resolution of failures. Any new validation tests performed due to changes or maintenance shall be logged into the logbook.

■ Validation test procedure

After wiring the Safe torque off function, validate its operation as follows.

Note: If the drive is equipped with safety option +Q972, +Q973 or +Q982, also do the procedure shown in the FSO module documentation.

If an FSCS-21 or FSPS-21 module is installed, refer to its documentation.

Action	<input checked="" type="checkbox"/>
 ▲WARNING Obey the safety instructions. If you ignore them, injury or death, or damage to the equipment can occur.	<input type="checkbox"/>
Make sure that the motor can be run and stopped freely during start-up.	<input type="checkbox"/>
Stop the drive (if running), switch the input power off and isolate the drive from the power line using a disconnecter.	<input type="checkbox"/>
Check the STO circuit connections against the wiring diagram.	<input type="checkbox"/>
Close the disconnecter and switch the power on.	<input type="checkbox"/>

242 The Safe torque off function

Action	<input checked="" type="checkbox"/>
<p>Test the operation of the STO function when the motor is stopped.</p> <ul style="list-style-type: none"> • Give a stop command for the drive (if running) and wait until the motor shaft is at a standstill. <p>Make sure that the drive operates as follows:</p> <ul style="list-style-type: none"> • Open the STO circuit. The drive generates an indication if one is defined for the 'stopped' state in parameter 31.22 (refer the firmware manual). • Give a start command to verify that the STO function blocks the drive's operation. The motor should not start. • Close the STO circuit. • Reset any active faults. Restart the drive and check that the motor runs normally. 	<input type="checkbox"/>
<p>Test the operation of the STO function when the motor is running.</p> <ul style="list-style-type: none"> • Start the drive and make sure the motor is running. • Open the STO circuit. The motor should stop. The drive generates an indication if one is defined for the 'running' state in parameter 31.22 (see the firmware manual). • Reset any active faults and try to start the drive. • Make sure that the motor stays at a standstill and the drive operates as described above in testing the operation when the motor is stopped. • Close the STO circuit. • Reset any active faults. Restart the drive and check that the motor runs normally. 	<input type="checkbox"/>
<p>Test the operation of the failure detection of the drive. The motor can be stopped or running.</p> <ul style="list-style-type: none"> • Open the 1st input channel of the STO circuit. If the motor was running, it should coast to a stop. The drive generates an FA81 fault indication (refer the firmware manual). • Give a start command to verify that the STO function blocks the drive's operation. The motor should not start. • Open the STO circuit (both channels). • Give a reset command. • Close the STO circuit (both channels). • Reset any active faults. Restart the drive and check that the motor runs normally. • Open the 2nd input channel of the STO circuit. If the motor was running, it should coast to a stop. The drive generates an FA82 fault indication (refer the firmware manual). • Give a start command to verify that the STO function blocks the drive's operation. The motor should not start. • Open the STO circuit (both channels). • Give a reset command. • Close the STO circuit (both channels). • Reset any active faults. Restart the drive and check that the motor runs normally. 	<input type="checkbox"/>
<p>Document and sign the validation test report which verifies that the safety function is safe and accepted for operation.</p>	<input type="checkbox"/>

Use

1. Open the activation switch, or activate the safety functionality that is wired to the STO connection.
2. The STO inputs on the drive control unit de-energize, and the control unit cuts off the control voltage from the output IGBTs.
3. The control program generates an indication as defined by parameter 31.22 (refer the firmware manual of the drive).
4. The motor coasts to a stop (if running). The drive will not restart while the activation switch or safety relay contacts are open.
5. Deactivate the STO by closing the activation switch, or resetting the safety functionality that is wired to the STO connection.
6. Reset any faults before restarting.



▲WARNING The Safe torque off function does not disconnect the voltage of the main and auxiliary circuits from the drive. Therefore maintenance work on electrical parts of the drive or the motor can only be carried out after isolating the drive from the supply and all other voltage sources.



▲WARNING The drive cannot detect or memorize any changes in the STO circuitry when the drive control unit is not powered or when the main power to the drive is off. If both STO circuits are closed and a level-type start signal is active when the power is restored, it is possible that the drive starts without a fresh start command. Take this into account in the risk assessment of the system.



▲WARNING Permanent magnet or synchronous reluctance [SynRM] motors only:

In case of a multiple IGBT power semiconductor failure, the drive can produce an alignment torque which maximally rotates the motor shaft by $180/p$ degrees (with permanent magnet motors) or $180/2p$ degrees (with synchronous reluctance [SynRM] motors) regardless of the activation of the Safe torque off function. p denotes the number of pole pairs.

Notes:

- If a running drive is stopped by using the Safe torque off function, the drive will cut off the motor supply voltage and the motor will coast to a stop. If this causes danger or is not otherwise acceptable, stop the drive and machinery using the appropriate stop mode before activating the Safe torque off function.
 - The Safe torque off function overrides all other functions of the drive.
 - The Safe torque off function is ineffective against deliberate sabotage or misuse.
 - The Safe torque off function has been designed to reduce the recognized hazardous conditions. In spite of this, it is not always possible to eliminate all potential hazards. The assembler of the machine must inform the final user about the residual risks.
-

Maintenance

After the operation of the circuit is validated at start-up, the STO function shall be maintained by periodic proof testing. In high demand mode of operation, the maximum proof test interval is 20 years. In low demand mode of operation, the maximum proof test interval is 10 years; refer section [Safety data \(page 247\)](#).

There are two alternative procedures for proof testing:

1. Perfect proof testing. It is assumed that all dangerous failures of the STO circuit are detected during the test. PFD_{avg} values for STO with the perfect proof testing procedure are given in the safety data section.
2. Simplified proof testing. This procedure is faster and simpler than perfect proof testing. Not all dangerous failures of the STO circuit are detected during the test. The PFD_{avg} value for STO with the simplified proof testing procedure is given in the safety data section.

Note: The proof testing procedures are only valid for proof testing (periodic test, item 5 under section [Start-up including validation test](#)) but not for re-validation after changes made in the circuit. Re-validation (items 1...4 under [Start-up including validation test](#)) must be done according to the initial validation procedure.

Note: Refer also the Recommendation of Use CNB/M/11.050 (published by the European co-ordination of Notified Bodies) concerning dual-channel safety-related systems with electromechanical outputs:

- When the safety integrity requirement for the safety function is SIL 3 or PL e (cat. 3 or 4), the proof test for the function must be performed at least every month.
- When the safety integrity requirement for the safety function is SIL 2 (HFT = 1) or PL d (cat. 3), the proof test for the function must be performed at least every 12 months.

The STO function of the drive does not contain any electromechanical components.

In addition to proof testing, it is a good practice to check the operation of the function when other maintenance procedures are carried out on the machinery.

Include the Safe torque off operation test described above in the routine maintenance program of the machinery that the drive runs.

If any wiring or component change is needed after start-up, or the parameters are restored, do the test given in section [Validation test procedure \(page 241\)](#).

Use only spare parts approved by ABB.

Record all maintenance and proof test activities in the machine logbook.

■ Competence

The maintenance and proof test activities of the safety function must be carried out by a competent person with adequate expertise and knowledge of the safety function as well as functional safety, as required by IEC 61508-1 clause 6.

■ Perfect proof test procedure

Action	<input checked="" type="checkbox"/>
 ▲WARNING Obey the safety instructions. If you ignore them, injury or death, or damage to the equipment can occur.	<input type="checkbox"/>
<p>Test the operation of the STO function. If the motor is running, it will stop during the test.</p> <ul style="list-style-type: none"> • Give a stop command for the drive (if running) and wait until the motor shaft is at a standstill. <p>Make sure that the drive operates as follows:</p> <ul style="list-style-type: none"> • Open the STO circuit. The drive generates an indication if one is defined for the 'stopped' state in parameter 31.22 (see the firmware manual). • Close the STO circuit. • Reset any active faults. Restart the drive and check that the motor runs normally. 	<input type="checkbox"/>
<p>Test the operation of the failure detection of the drive. The motor can be stopped or running.</p> <ul style="list-style-type: none"> • Open the 1st input channel of the STO circuit. If the motor was running, it should coast to a stop. The drive generates an FA81 fault indication (see the firmware manual). • Open the STO circuit (both channels). • Give a reset command. • Close the STO circuit (both channels). • Reset any active faults. • Open the 2nd input channel of the STO circuit. If the motor was running, it should coast to a stop. The drive generates an FA82 fault indication (see the firmware manual). • Open the STO circuit (both channels). • Give a reset command. • Close the STO circuit (both channels). • Reset any active faults. Restart the drive and check that the motor runs normally. 	<input type="checkbox"/>
Document and sign the test report to verify that the safety function has been tested according to the procedure.	<input type="checkbox"/>

■ Simplified proof test procedure

Action	<input checked="" type="checkbox"/>
 ▲WARNING Obey the safety instructions. If you ignore them, injury or death, or damage to the equipment can occur.	<input type="checkbox"/>
<p>Test the operation of the STO function. If the motor is running, it will stop during the test.</p> <ul style="list-style-type: none"> • Give a stop command for the drive (if running) and wait until the motor shaft is at a standstill. <p>Make sure that the drive operates as follows:</p> <ul style="list-style-type: none"> • Open the STO circuit. The drive generates an indication if one is defined for the 'stopped' state in parameter 31.22 (see the firmware manual). • Close the STO circuit. • Reset any active faults. Restart the drive and check that the motor runs normally. 	<input type="checkbox"/>
Document and sign the test report to verify that the safety function has been tested according to the procedure.	<input type="checkbox"/>

Fault tracing

The indications given during the normal operation of the Safe torque off function are selected by drive control program parameter 31.22.

The diagnostics of the Safe torque off function cross-compare the status of the two STO channels. In case the channels are not in the same state, a fault reaction function is performed and the drive trips on an FA81 or FA82 fault. An attempt to use the STO in a non-redundant manner, for example activating only one channel, will trigger the same reaction.

Refer the firmware manual of the drive control program for the indications generated by the drive, and for details on directing fault and warning indications to an output on the control unit for external diagnostics.

Any failures of the Safe torque off function must be reported to ABB.

Safety data

The safety data for the Safe torque off function is given below.

Note: The safety data is calculated for redundant use, and applies only if both STO channels are used.

Frame size	SIL	SC	PL	PFH (1/h)	PFD _{avg}		MTTF _D (a)	DC (%)	SFF (%)	Cat.	HFT	CCF	T _M (a)	PFH _{diag} (1/h)	λ _{Diag,s} (1/h)	λ _{Diag,d} (1/h)
					Perfect proof test T ₁ = 5 a	Simplified proof test T ₁ = 5 or 10 a										
R10 R11	3	3	e	3.65E-09	8.00E-05	1.60E-04	3.20E-04	≥90	>90	3	1	80	20	6.20E-09	8.30E-07	1.80E-08
3AXD10001609376 C																

- Drives with UCU-20 control unit (option +V998): The values for DC, PFH_{diag} , λ_{Diag_s} and λ_{Diag_d} in the table are according to ISO 13849-1. These values are not claimed according to IEC 61508. For drives with other control units, the values for DC, PFH_{diag} , λ_{Diag_s} and λ_{Diag_d} are according to ISO 13849-1 and IEC 61508.
- The STO is a type A safety component as defined in IEC 61508-2.
- Relevant failure modes:
 - The STO trips spuriously (safe failure)
 - The STO does not activate when requested
 - A fault exclusion on the failure mode “short circuit on printed circuit board” has been made (EN 13849-2, table D.5). The analysis is based on an assumption that one failure occurs at one time. No accumulated failures have been analyzed.
- STO response times:
 - STO reaction time (shortest detectable break): 1 ms
 - STO response time: 2 ms (typical), 30 ms (maximum)
 - Fault detection time: Channels in different states for longer than 200 ms
 - Fault reaction time: Fault detection time + 10 ms.
- Indication delays:
 - STO fault indication (parameter 31.22) delay: < 500 ms
 - STO warning indication (parameter 31.22) delay: < 1000 ms.

■ **Terms and abbreviations**

Term or abbreviation	Reference	Description
Cat.	EN ISO 13849-1	Classification of the safety-related parts of a control system in respect of their resistance to faults and their subsequent behavior in the fault condition, and which is achieved by the structural arrangement of the parts, fault detection and/or by their reliability. The categories are: B, 1, 2, 3 and 4.
CCF	EN ISO 13849-1	Common cause failure (%)
DC	EN ISO 13849-1	Diagnostic coverage (%)
HFT	IEC 61508	Hardware fault tolerance
$MTTF_D$	EN ISO 13849-1	Mean time to dangerous failure: (Total number of life units) / (Number of dangerous, undetected failures) during a particular measurement interval under stated conditions
PFD_{avg}	IEC 61508	Average probability of dangerous failure on demand, that is, mean unavailability of a safety-related system to perform the specified safety function when a demand occurs
PFH	IEC 61508	Average frequency of dangerous failures per hour, that is, average frequency of a dangerous failure of a safety related system to perform the specified safety function over a given period of time
PFH_{diag}	IEC/EN 62061	Average frequency of dangerous failures per hour for the diagnostic function of STO
PL	EN ISO 13849-1	Performance level. Levels a...e correspond to SIL
Proof test	IEC 61508, IEC 62061	Periodic test performed to detect failures in a safety-related system so that, if necessary, a repair can restore the system to an "as new" condition or as close as practical to this condition
SC	IEC 61508	Systematic capability (1...3)
SFF	IEC 61508	Safe failure fraction (%)
SIL	IEC 61508	Safety integrity level (1...3)

250 The Safe torque off function

Term or abbreviation	Reference	Description
STO	IEC/EN 61800-5-2	Safe torque off
T_1	IEC 61508-6	Proof test interval. T_1 is a parameter used to define the probabilistic failure rate (PFH or PFD) for the safety function or subsystem. Performing a proof test at a maximum interval of T_1 is required to keep the SIL capability valid. The same interval must be followed to keep the PL capability (EN ISO 13849) valid. See also section Maintenance.
T_M	EN ISO 13849-1	Mission time: the period of time covering the intended use of the safety function/device. After the mission time elapses, the safety device must be replaced. Note that any T_M values given cannot be regarded as a guarantee or warranty.
λ_{Diag_d}	IEC 61508-6	Dangerous failure rate (per hour) of the diagnostics function of STO
λ_{Diag_s}	IEC 61508-6	Safe failure rate (per hour) of the diagnostics function of STO

■ TÜV certificate

The TÜV certificate is available on the Internet.

20

Resistor braking

Contents of this chapter

This chapter describes how to select, protect and wire brake choppers and resistors. The chapter also contains the technical data.

When to use resistor braking

Resistor braking is necessary for high capacity braking of the motor and machinery if a regenerative drive cannot be used.

Operation principle and hardware description

The drive can be equipped with optional built-in brake chopper (+D150). Brake resistors are available as add-on kits.

The brake chopper handles the extra energy generated by motor during a quick deceleration. The extra energy increases the drive DC link voltage. The chopper connects the brake resistor to the DC link whenever the voltage is higher than the operation limit of the chopper. Energy consumption by the resistor losses lowers the voltage until it is below the limit at which the chopper stops.

Planning the braking system

■ Generic guidelines

This section contains generic brake cable type, length and placing instructions, rules on how to minimize electromagnetic interference and descriptions and requirements for protections.

Resistor cables

Cable type

Use the same cable type for the resistor cabling as for the drive input cabling or, alternatively, a two conductor shielded cable with the same cross-sectional area.

Maximum cable length

The maximum length of the resistor cable(s) is 10 m (33 ft).

Minimizing electromagnetic interference

Make sure that the installation is compliant with the EMC requirements. Obey these rules in order to minimize electromagnetic interference caused by the rapid voltage and current changes in the resistor cables:

- Shield the brake resistor cable. Use shielded cable or a metallic enclosure. If you use unshielded single-core cables, route them inside a cabinet that efficiently suppresses the radiated emissions.
- Install the cables away from other cable routes.
- Avoid long parallel runs with other cables. The minimum parallel cabling separation distance is 0.3 meters (1 ft).
- Cross the other cables at 90° angles.
- Keep the cable as short as possible in order to minimize the radiated emissions and stress on the brake chopper. The longer the cable the greater the radiated emissions, inductive load and voltage peaks over the IGBT semiconductors of the brake chopper.

Protecting the resistor cable against short-circuits

The input fuses of the drive will also protect the resistor cable when it is identical with the input cable.

Resistor thermal switch

Use a resistor with a thermal switch (standard in ABB resistors).

Make sure that the cable in the resistor thermal switch circuit meets the following requirements:

- shielded cable
- rated operating voltage between a core and ground $> 750 (U_0)$
- insulation test voltage > 2.5 kV
- jacket material for at least 90 °C (194 °F). Take into account further requirements due to resistor construction and temperature.

Protecting the system against thermal overload

The brake chopper protects itself and the resistor cables against thermal overload when the cables are dimensioned according to the nominal current of the drive. The drive control program includes a resistor overload protection function which can be tuned by the user. See the firmware manual.

EMC compliance of the complete installation

ABB cannot test that the EMC requirements are fulfilled with custom brake resistors and cabling. The customer must consider the EMC compliance of the complete installation.

Selecting the installation location for the brake resistors

Protect the open (IP00) brake resistors against contact. Install the brake resistor in a place where it cools effectively. Arrange the cooling of the resistor so that:

- no danger of overheating is caused to the resistor or nearby materials, and
- the temperature of the space that the resistor is in does not go above the allowed maximum value.



▲WARNING The materials near the brake resistor must be non-flammable. The surface temperature of the resistor is high. Airflow from the resistor can have a high temperature. If the exhaust vents connect to a ventilation system, make sure that the material withstands high temperatures. Protect the resistor against contact.

■ Protecting the system in fault situations

A main contactor is not required for protecting against resistor overheating when the resistor is dimensioned according to the instructions and the internal brake chopper is in use. The drive will disable power flow through the input bridge if the chopper remains conductive in a fault situation but the charging resistor may fail.

Note: If an external brake chopper (outside the drive module) is used, ABB always requires a main contactor.

■ Selecting the drive, brake chopper and brake resistor

For the ratings of the brake choppers and resistors, refer to the resistor braking technical data.

1. Define the basic data: maximum power generated by the motor during the braking (P_{br}), braking time (t_{br}) and braking cycle time (T).
2. Select the drive. Take its resistor braking capacity into account. The power rating of the drive and brake chopper (P_{brmax}) must be greater than or equal to P_{br} .
3. Make sure that the ABB default brake resistor assembly can dissipate the braking energy. The energy generated by the motor during one resistor heat dissipation period (400 s) must be equal to or smaller than the heat dissipation capacity (E_R) of the resistor assembly. If it is not, you cannot use the default ABB resistor assembly. These alternatives are possible:
 - If it is possible, decrease the braking power or braking time, or prolong the braking cycle time.
 - Select a custom brake resistor with high enough heat dissipation capacity. The resistance may not be smaller than the minimum value defined for the chopper.
 - Use multiple of the ABB default brake resistors. Make sure that the total resistance seen from the brake chopper terminals remains unchanged. An example connection is shown below. The connection of an ABB default brake resistor assembly is on the left (two resistors). The equivalent multiple resistor

connection is on the right (8 resistors). The heat dissipation capacity is four times bigger.

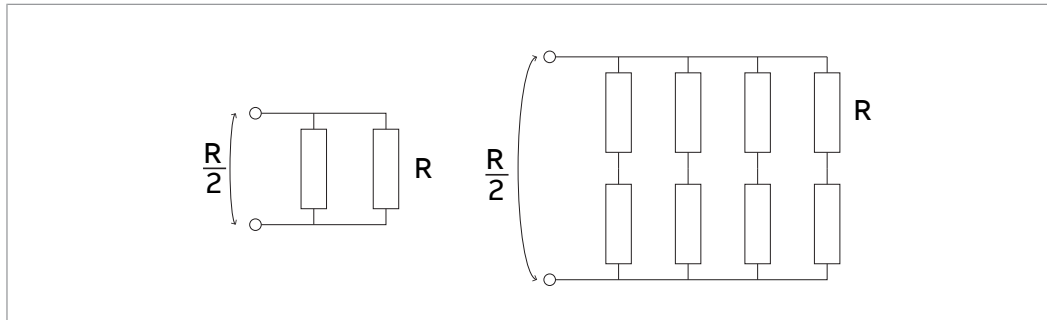

■ Calculation example

Drive: ACS880-04-583A-5. Maximum continuous braking power (P_{brcont}) of the internal brake chopper = 315 kW. Preselected ABB resistor = 2×SAFUR200F50. Braking power of the motor is 300 kW. The duration of a braking cycle (T) is three minutes -> number of braking pulses in 400 seconds = 2.2. The braking time (t_{br}) is 20 seconds.

$P_{br} = 300 \text{ kW} < P_{brcont} = 315 \text{ kW}$. This is ok.

The energy generated by the motor during a 400-second period = $2.2 \times 300 \text{ kW} \times 20 \text{ s} = 13200 \text{ kJ}$. The brake resistor withstands an energy pulse of 10800 kJ in every 400 seconds period. $13200 \text{ kJ} > 10800 \text{ kJ}$. -> The resistor is too small. -> Decrease the braking power or braking time or select a custom brake resistor as described in section [Selecting a custom brake resistor \(page 254\)](#).

■ Selecting a custom brake resistor

If you want to use custom brake resistor instead of the default ABB resistor:

1. Make sure that the brake resistor resistance not too low, ie, this equation is true. Too low resistance causes overcurrent.

$$R \geq R_{min}$$

where

R Resistance of the custom brake resistor

R_{min} Minimum permitted resistance for the brake resistor



▲ CAUTION Do not use a brake resistor with a resistance lower than the specified minimum value. It causes overcurrent that damages the brake chopper and the drive.

2. Make sure that the brake resistor resistance is not too high, ie, this equation is true. Too high resistance limits the braking capacity.

$$P_{max} < \frac{U_{DC}^2}{R}$$

where

P_{max} Maximum power generated by the motor during the braking

U_{DC} Drive DC voltage during the braking:

1.35 · 1.2 · 415 V (when supply voltage is 380 ... 415 V AC)

1.35 · 1.2 · 500 V (when supply voltage is 440 ... 500 V AC)

1.35 · 1.2 · 690 V (when supply voltage is 525 ... 690 AC)

R Resistance of the custom resistor

3. Make sure that the brake resistor voltage rating match with the drive DC voltage during the braking. See the drive DC voltage values in the table above.
4. Make sure that the resistor can dissipate the energy transferred to it during the braking:
 - Braking energy does not exceed the resistor heat dissipation capacity (E_r) during the specified period.
 - The resistor is installed in a space that is sufficiently cooled to prevent excessive heat accumulation.
5. If you want to monitor the actual resistor temperature, make sure that the resistor has a temperature sensor.

Mechanical installation of resistors

All brake resistors must be installed outside the drive. Obey the resistor manufacturer's instructions.

Electrical installation

■ Measuring the insulation of the assembly

Obey the instructions given in section [Measuring the insulation resistance of the brake resistor circuit \(page 103\)](#).

■ Connection diagram

See section [Power cable connection diagram \(page 105\)](#).

■ Connection procedure

- Connect the resistor cables to the R+ and R- terminals in the same way as the other power cables. If a shielded three-conductor cable is used, cut the third conductor and ground the twisted shield of the cable (protective earth conductor of the resistor assembly) at both ends.
- Wire the thermal switch to a digital input on the drive control unit as shown below.

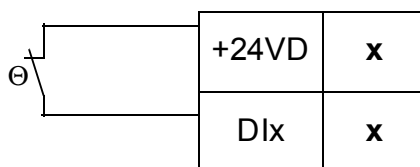

Start-up



▲WARNING Make sure that there is sufficient ventilation. New brake resistors can have a protective grease coating. When the resistor warms up for the first time, the grease burns off and can cause some smoke.

■ Parameter settings

This section describes the parameter settings for an example application in which:

- Drive uses brake resistor thermal model for the resistor overload protection.
- The brake resistor has a temperature sensor. The drive monitors the sensor status via a digital input. An overtemperature indication causes a fault trip.

Set parameters in the example application as follows:

- Set parameter 30.30 to value Disable. This disables the overvoltage control of the drive DC link. the brake chopper operation is possible.
- Set parameter 43.06 to Enabled with thermal model. This enables the brake chopper operation and activates the brake resistor overload protection function with the thermal model.
- Set parameters 43.08, 43.09 and 43.10 according to the brake resistor data. These parameters define the thermal time constant, continuous power rating and resistance for the brake resistor thermal model.
- Set parameters 43.11 and 43.12 to suitable values. They define the warning and fault resistor temperature limits for the brake resistor thermal model.
- Set parameter 31.01 to point to the digital input to which the brake resistor temperature sensor is connected. This defines the source for the external event 1 function.
- Set parameter 31.02 to Fault. This defines fault as the event type for the external event 1 function.



▲WARNING If you disable the brake chopper with a parameter setting, also disconnect the brake resistor cable from the drive. Otherwise, there is a risk of resistor overheating and damage.

Technical data

■ Ratings

The table below gives the ratings for resistor braking.

ACS880-04-...	Internal brake chopper		Example brake resistor(s)			
	P_{brcont}	R_{min}	Type	R	E_R	P_{Rcont}
	kW	ohm		ohm	kJ	kW
$U_n = 400\text{ V}$						
505A-3	250	2.0	2×SAFUR125F500	2.0	7200	18
585A-3	315	1.3	2×SAFUR200F500	1.3	10800	27
650A-3	315	1.3	2×SAFUR200F500	1.3	10800	27
725A-3	400	0.7	3×SAFUR200F500	0.9	16200	40
820A-3	400	0.7	3×SAFUR200F500	0.9	16200	40
880A-3	400	0.7	3×SAFUR200F500	0.9	16200	40
$U_n = 500\text{ V}$						
460A-5	250	2.0	2×SAFUR125F500	2.0	7200	18
503A-5	250	2.0	2×SAFUR125F500	2.0	7200	18
583A-5	315	1.3	2×SAFUR200F500	1.3	10800	27
635A-5	315	1.3	2×SAFUR200F500	1.3	10800	27
715A-5	400	0.7	3×SAFUR200F500	0.9	16200	40
820A-5	400	0.7	3×SAFUR200F500	0.9	16200	40
880A-5	400	0.7	3×SAFUR200F500	0.9	16200	40
$U_n = 690\text{ V}$						
330A-7	285	2.2	SAFUR200F500	2.7	3600	13
370A-7	285	2.2	SAFUR200F500	2.7	3600	13
430A-7	285	2.2	SAFUR200F500	2.7	3600	13
470A-7	350	2.0	2×SAFUR125F500	2.0	7200	18
522A-7	350	2.0	2×SAFUR125F500	2.0	7200	18
590A-7	400	1.8	2×SAFUR125F500	2.0	7200	18
650A-7	400	1.8	2×SAFUR125F500	2.0	7200	18
721A-7	400	1.8	2×SAFUR125F500	2.0	7200	18

P_{brcont} Maximum continuous braking power. The braking is considered continuous if the braking time exceeds 30 seconds.

R_{min} Minimum permitted resistance value for the brake resistor

R Resistance value of the ABB default brake resistor

E_R Energy pulse that the ABB default brake resistor withstands and can dissipate every 400 seconds

P_{Rcont} Continuous heat dissipation capacity (power) of the resistor when placed correctly

The ratings apply at an ambient temperature of 40 °C (104 °F).

■ SAFUR resistor data

These features are common to all SAFUR resistors:

258 Resistor braking

- Degree of protection: IP00 (open)
- Resistor cable tightening torque: 9 N·m
- Thermal time constant: 555 s
- In-built overheat temperature sensor
- Not UL listed.

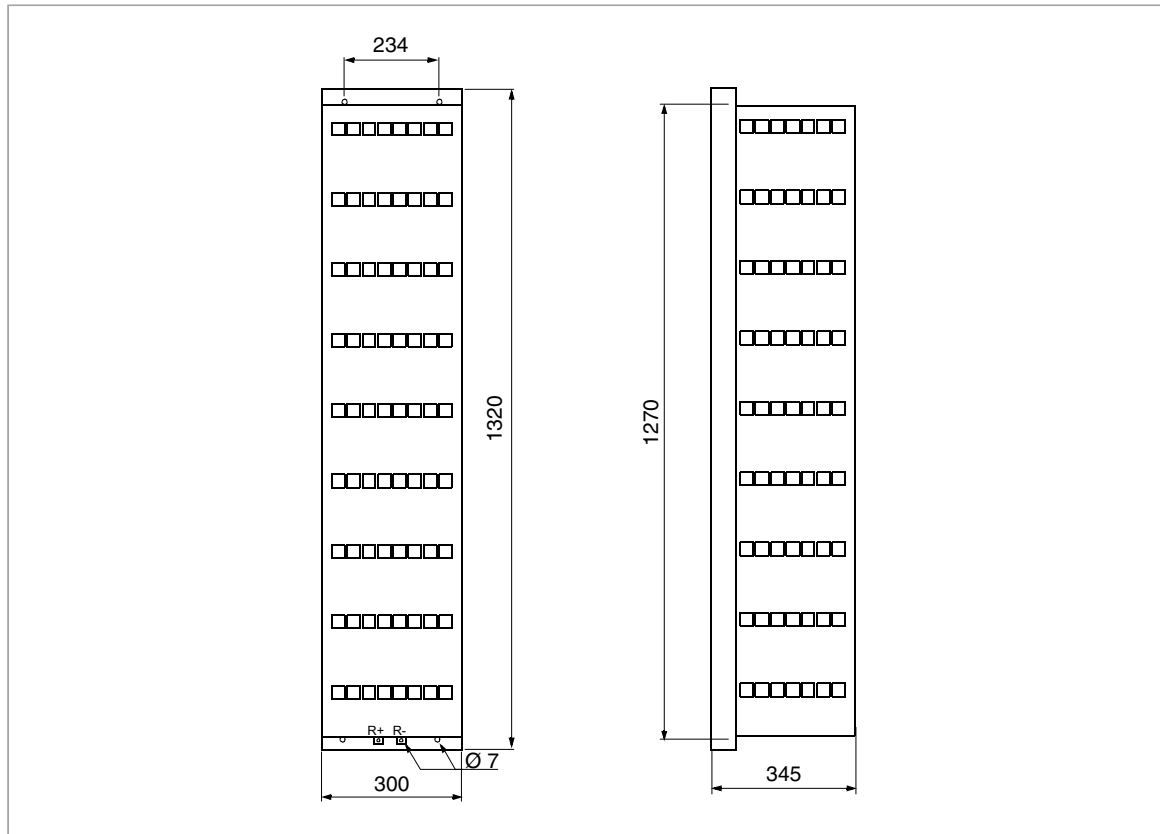

Brake resistor type	R [ohm]	E_r [kJ]	P_{Rcont} [kW]	Weight	ABB ordering code
SAFUR125F500	4.0	3600	9	25 kg (55 lb)	68759285
SAFUR200F500	2.7	5400	13.5	30 kg (66 b)	68759340

R Resistance

E_R Energy pulse that the ABB default brake resistor withstands during a 400 s duty cycle. This energy will heat the resistor element from 40 °C to the maximum allowable temperature.

P_{Rcont} Continuous heat dissipation capacity (power) of the resistor when placed correctly

■ Terminals and cable entry data

See section [Terminal and entry data for the power cables \(page 197\)](#).

21

Filters

Contents of this chapter

This chapter describes how to select du/dt and sine filters for the drive.

du/dt filters

- **When is a du/dt filter necessary?**

See [Examining the compatibility of the motor and drive \(page 74\)](#).

- **Selection table**

du/dt filter types for the drive modules are given below.

ACS880-04-...	du/dt filter type	ACS880-04-...	du/dt filter type	ACS880-04-...	du/dt filter type
$U_n = 400\text{ V}$		$U_n = 500\text{ V}$		$U_n = 690\text{ V}$	
505A-3	FOCH0610-70	460A-5	FOCH0610-70	330A-7	FOCH0610-70
585A-3	FOCH0610-70	503A-5	FOCH0610-70	370A-7	FOCH0610-70
650A-3	FOCH0610-70	583A-5	FOCH0610-70	430A-7	FOCH0610-70
725A-3	FOCH0875-70	635A-5	FOCH0610-70	470A-7	FOCH0610-70
820A-3	FOCH0875-70	715A-5	FOCH0875-70	522A-7	FOCH0610-70
880A-3	FOCH0875-70	820A-3	FOCH0875-70	590A-7	FOCH0610-70
-	-	880A-5	FOCH0875-70	650A-7	FOCH0875-70
-	-	-	-	721A-7	FOCH0875-70

■ Ordering codes

Filter type	ABB ordering code
FOCH0610-70	68550505
FOCH0875-70	3AUA0000129544

■ Description, installation and technical data of the FOCH filters

See [FOCH du/dt filters hardware manual \(3AFE68577519 \[English\]\)](#).

Sine filters

■ When is a sine filter necessary?

See section [Examining the compatibility of the motor and drive \(page 74\)](#).

■ Selection table

Sine filter types for the drive modules are given below.

ACS880-04-...	Sine filter type	ACS880-04-...	Sine filter type	ACS880-04-...	Sine filter type
$U_n = 400\text{ V}$		$U_n = 500\text{ V}$		$U_n = 690\text{ V}$	
505A-3	NSIN0900-6	460A-5	NSIN0485-6	330A-7	NSIN0485-6
585A-3	NSIN0900-6	503A-5	NSIN0900-6	370A-7	NSIN0485-6
650A-3	NSIN0900-6	583A-5	NSIN0900-6	430A-7	NSIN0485-6
725A-3	NSIN0900-6	635A-5	NSIN0900-6	470A-7	NSIN0485-6
820A-3	NSIN0900-6	715A-5	NSIN0900-6	522A-7	NSIN0485-6
880A-3	NSIN0900-6	820A-3	NSIN0900-6	590A-7	NSIN0900-6
-	-	880A-5	NSIN0900-6	650A-7	NSIN0900-6
-	-	-	-	721A-7	NSIN0900-6

■ Ordering codes

Filter type	ABB ordering code
NSIN0485-6	64254936
NSIN0900-6	64254961

■ Derating

See section [Deratings for special settings in the drive control program \(page 185\)](#).

■ Description, installation and technical data of the sine filters

See [Sine filters hardware manual \(3AXD50000016814 \[English\]\)](#). For more information, contact ABB.

22. Step-by-step drawings for an installation example of standard drive configuration with option +E208 in Rittal VX25 600 mm wide enclosure

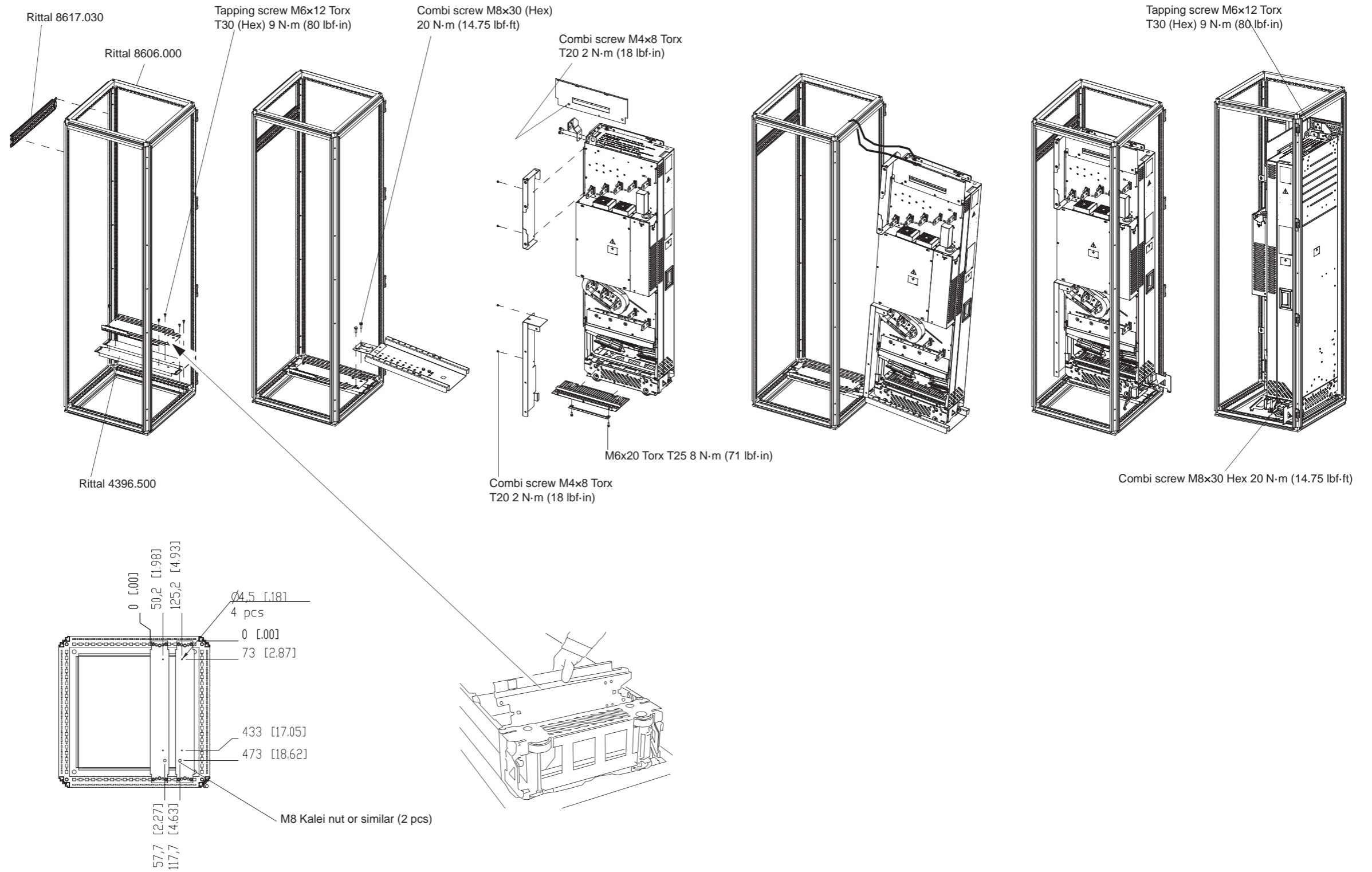

262 Step-by-step drawings for an installation example of standard drive configuration with option +E208 in Rittal VX25 600 mm wide enclosure

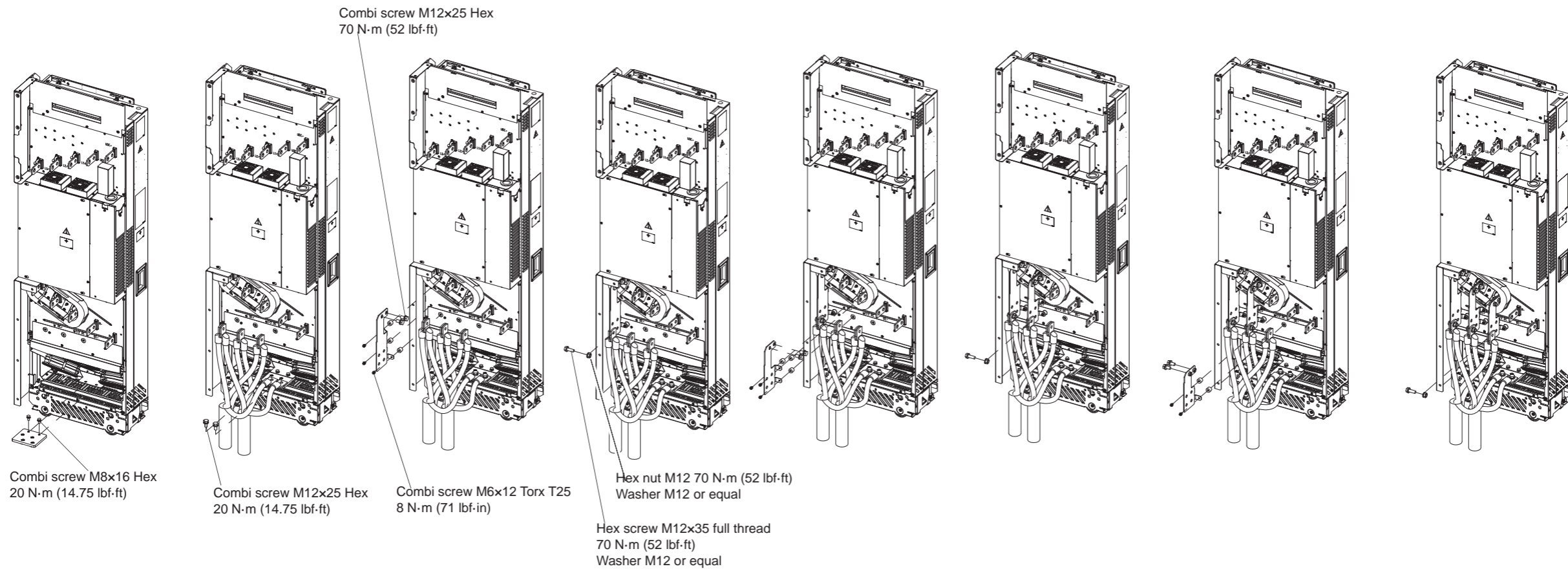

Step-by-step drawings for an installation example of standard drive configuration with option +E208 in Rittal VX25 600 mm wide enclosure 263

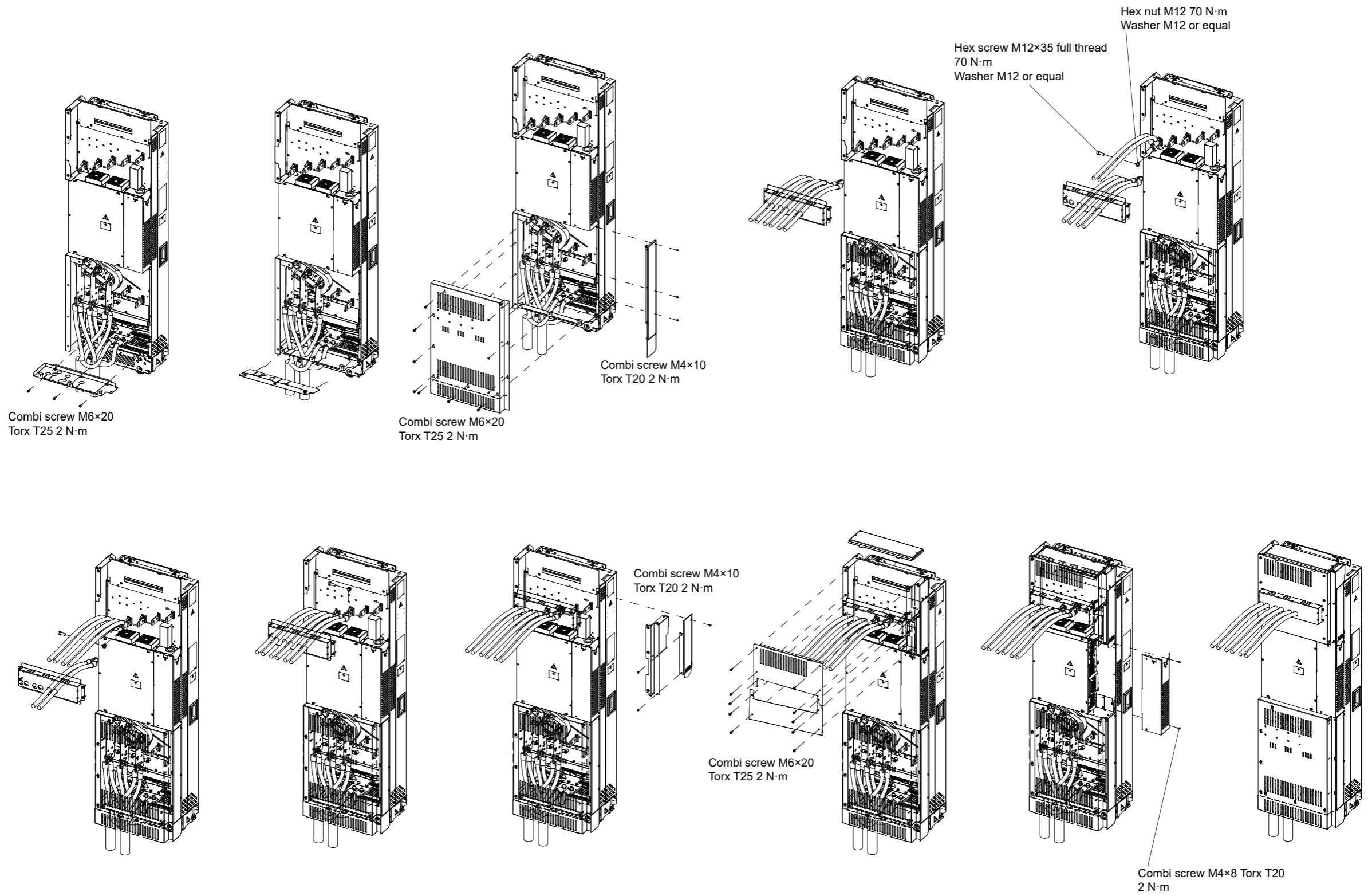

264 Step-by-step drawings for an installation example of standard drive configuration with option +E208 in Rittal VX25 600 mm wide enclosure

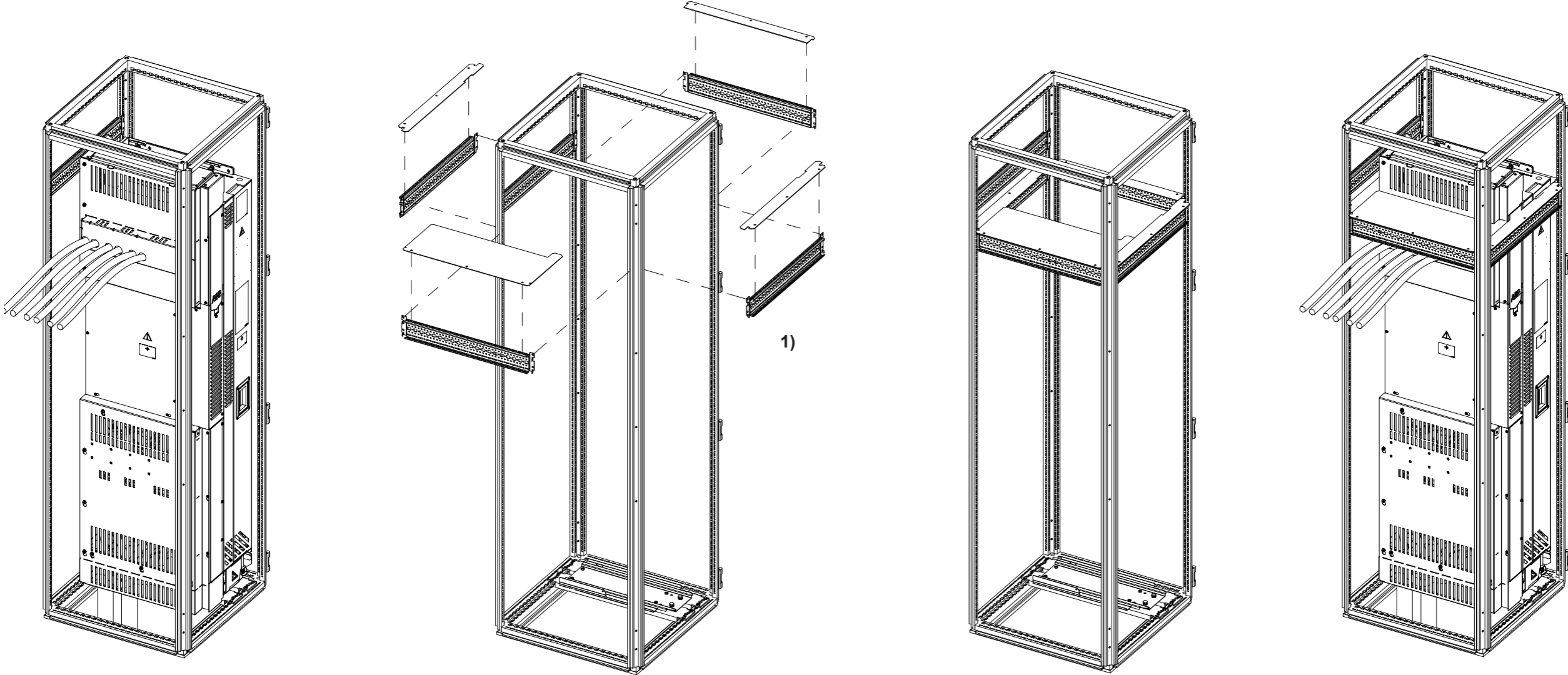

Step-by-step drawings for installation example 2 - Bookshelf installation (option +H381) in a Rittal VX25 400 mm enclosure

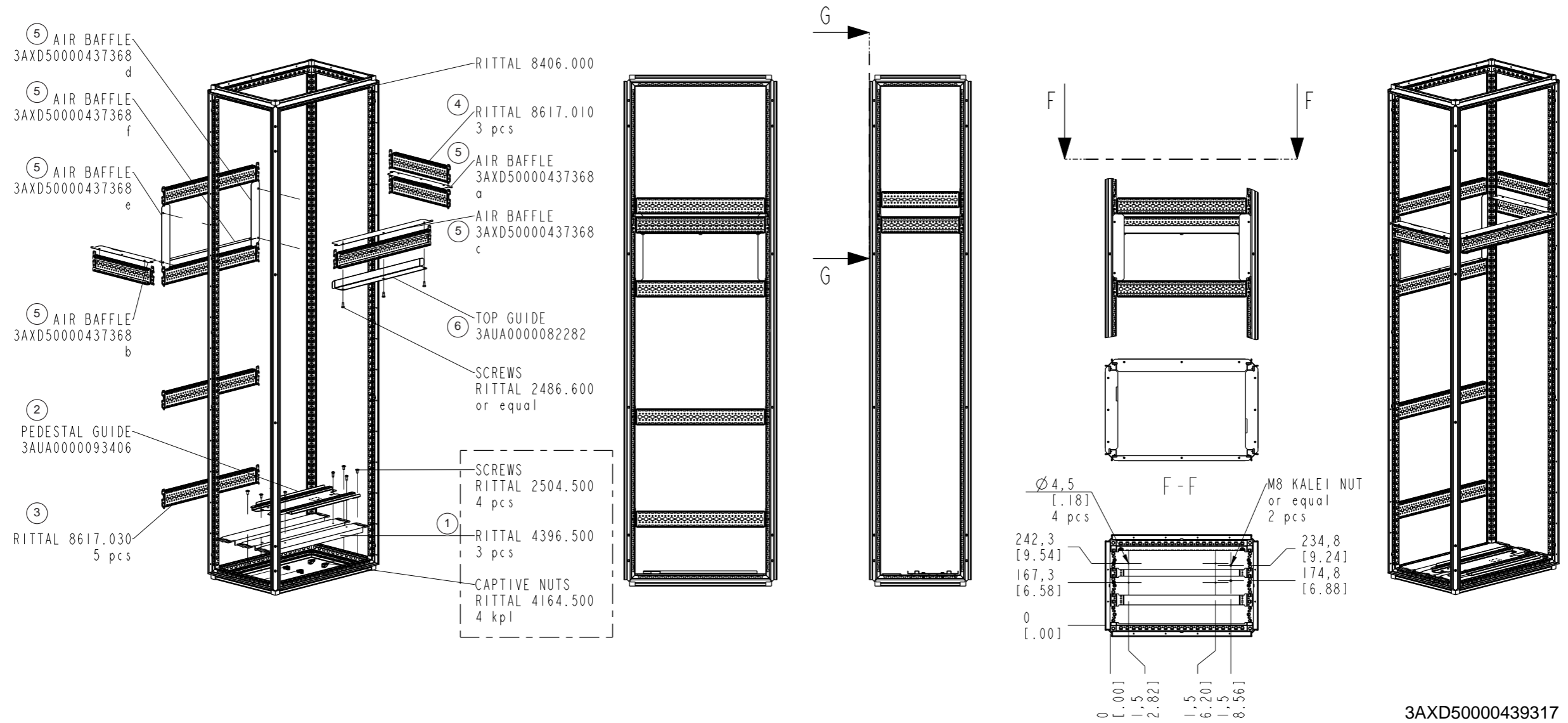

266 Step-by-step drawings for installation example 2 - Bookshelf installation (option +H381) in a Rittal VX25 400 mm enclosure

ABB parts	
2	Pedestal guide plate
6	Top guide plate
Customer-made parts (not ABB or Rittal product)	
5	Air baffles

Installation procedure

1. Install three Rittal support rails (4396.500) on the bottom of the enclosure.
2. Install the pedestal guide onto the support rails.
3. Install the Rittal punched sections 8617.030 (5 pcs).
4. Install the Rittal punched sections 8617.010 (3 pcs).
5. Install the air baffles.
6. Install the top guide plate.

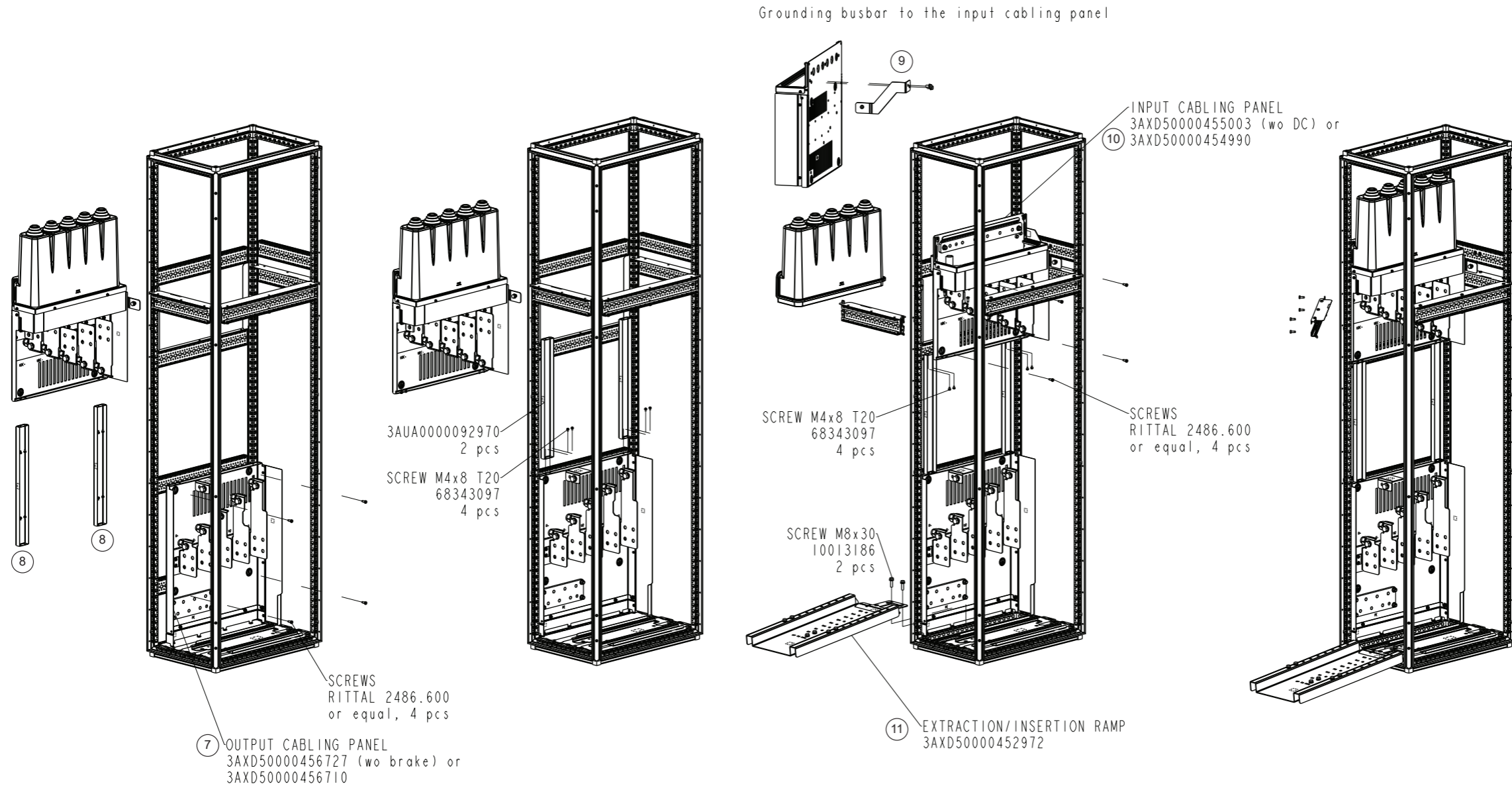

Installation procedure (continued)

7. Install the output cabling panel.
8. Install the side guides to the output cabling panel (2 screws for each side guide).
9. Attach the grounding busbar to the input cabling panel. Back view is shown above.
10. Attach the input cabling panel to the punched section.
11. Install the telescopic extraction and insertion ramp.

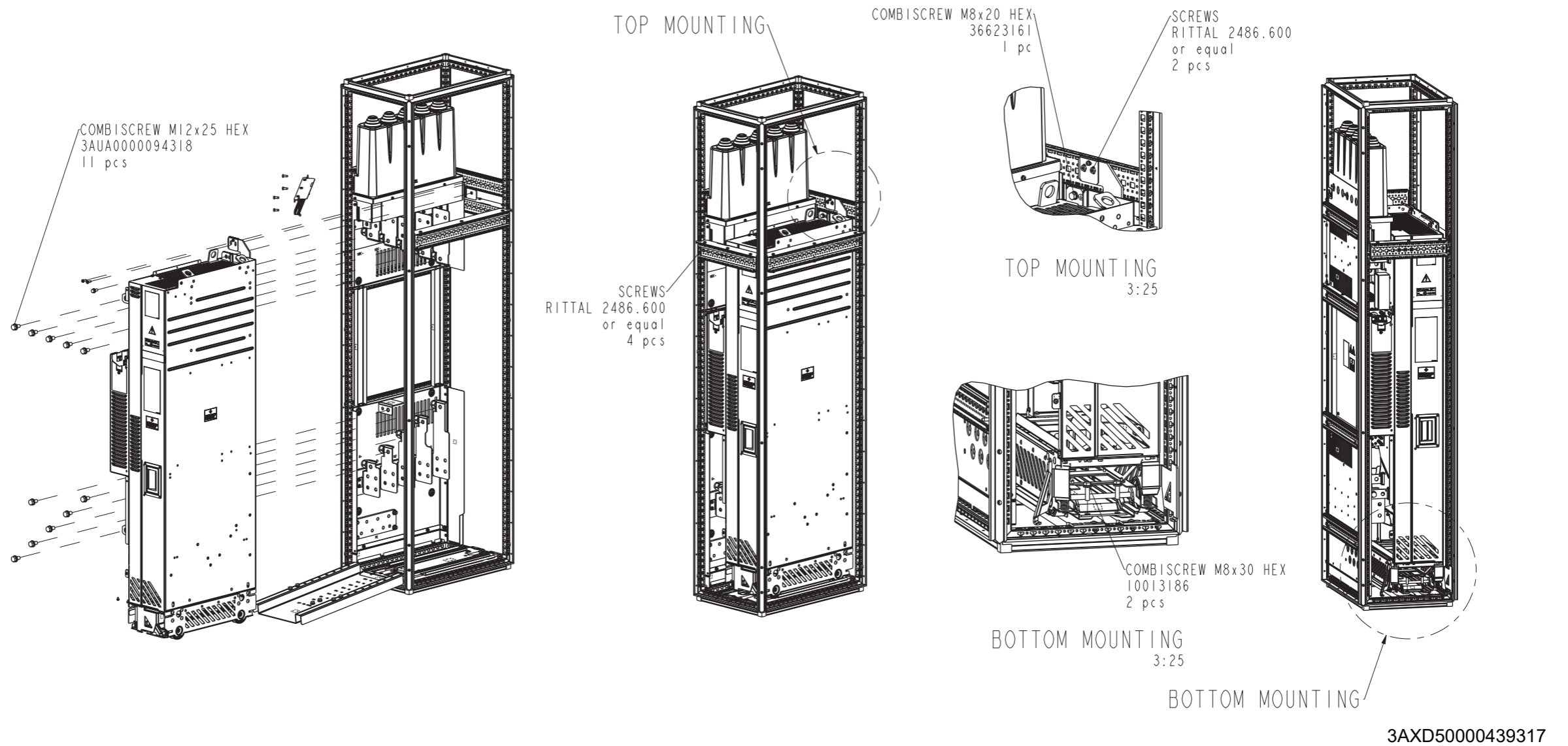

268 Step-by-step drawings for installation example 2 - Bookshelf installation (option +H381) in a Rittal VX25 400 mm enclosure

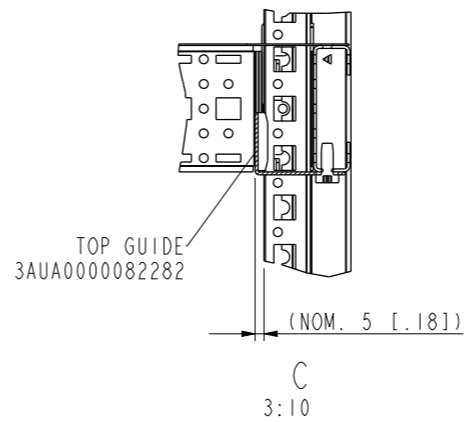
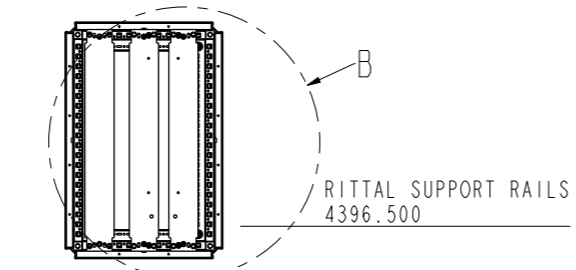
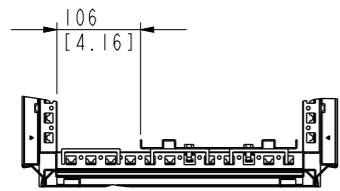
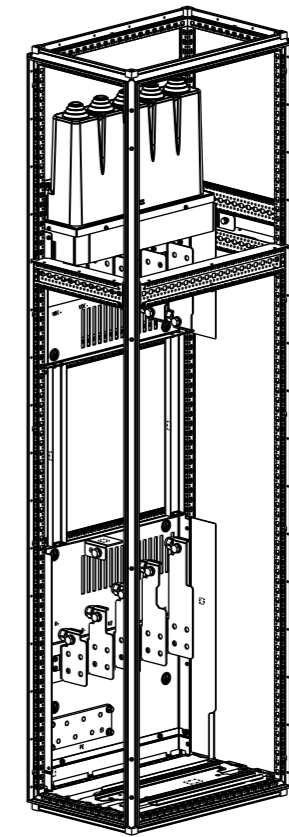
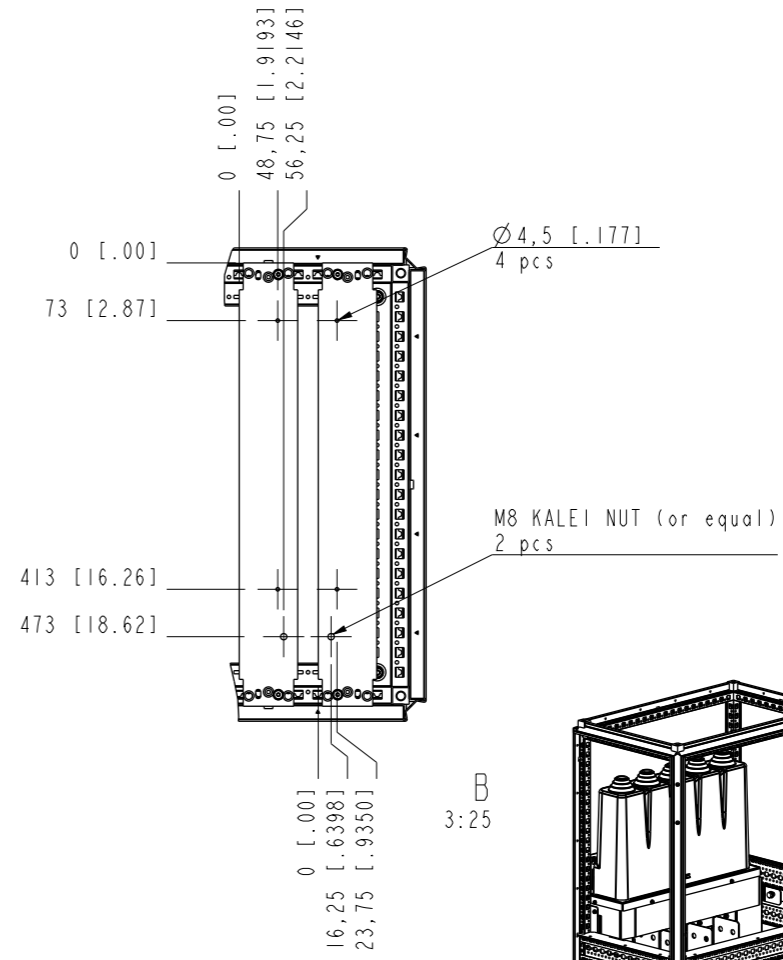
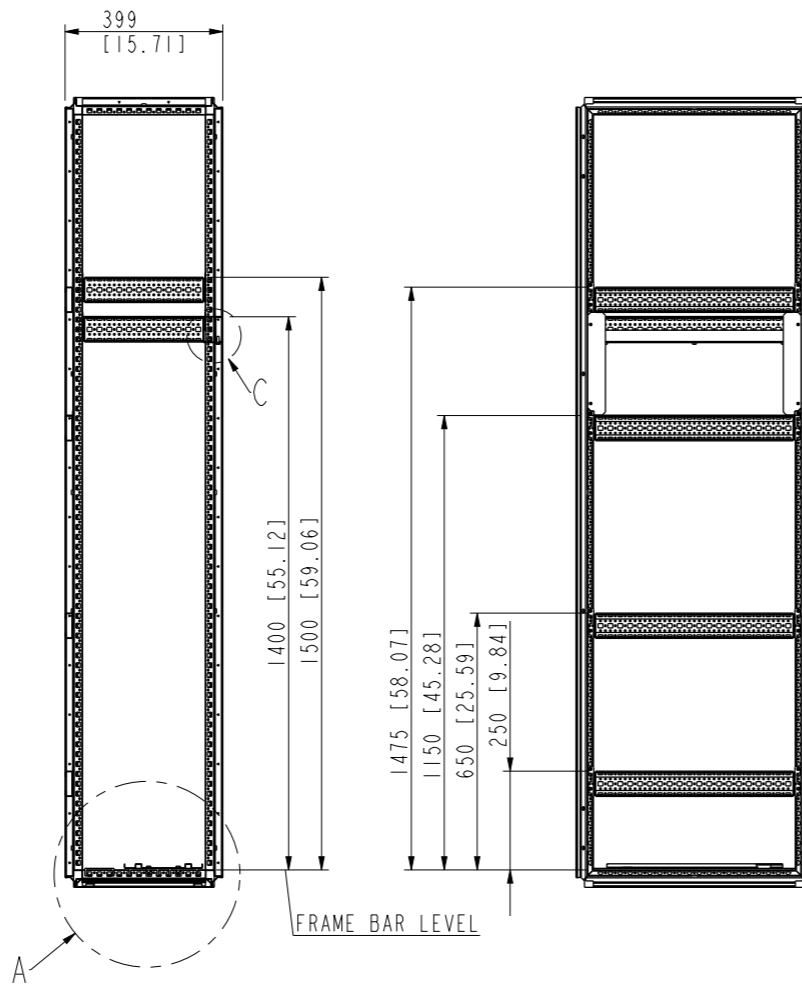
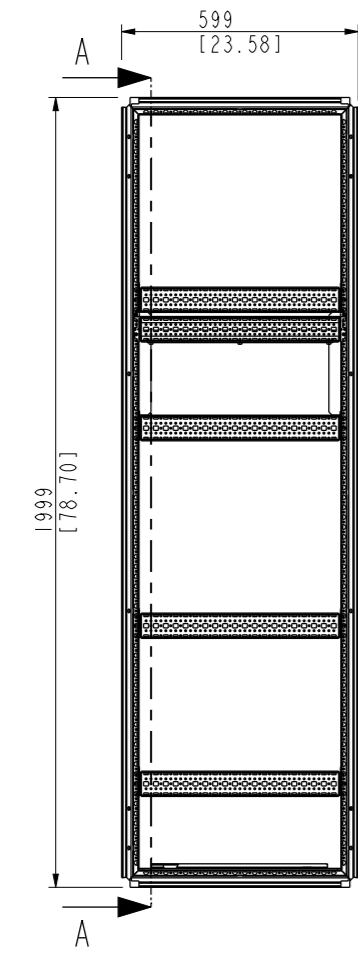

A
3:25

LEAD THROUGH AREA

SCREWS
RITTAL 2486.600
10 pcs

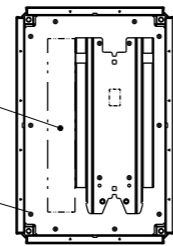

BOTTOM PLATE
3AXD50000433988

B
3:25

C
3:10

3AXD50000439317

23. Step-by-step drawings for a flat installation example in a Rittal VX25 600 mm wide enclosure

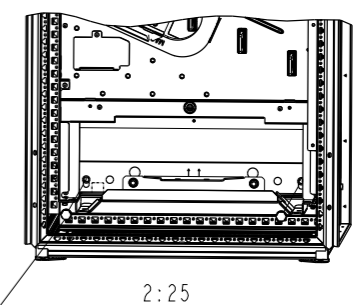
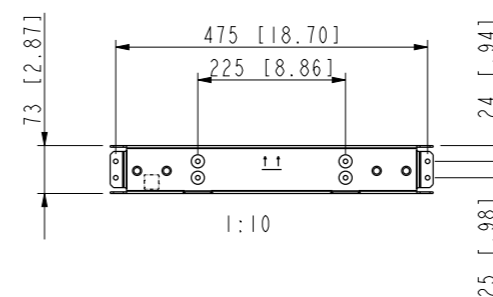
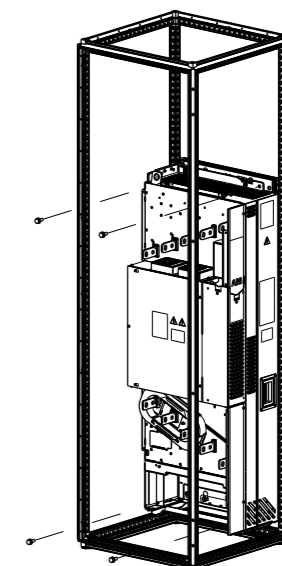
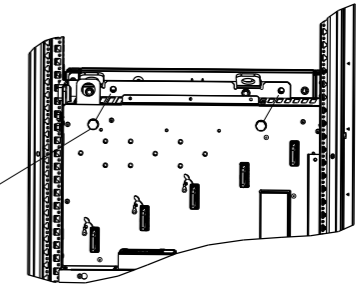
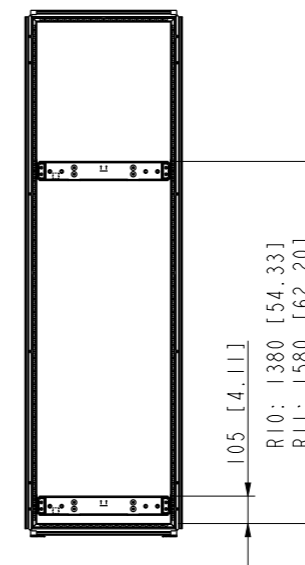
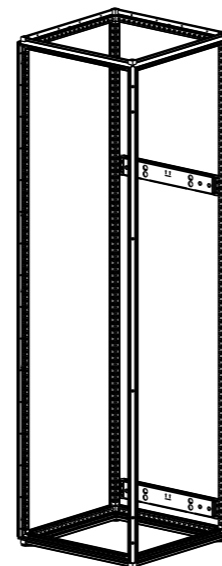
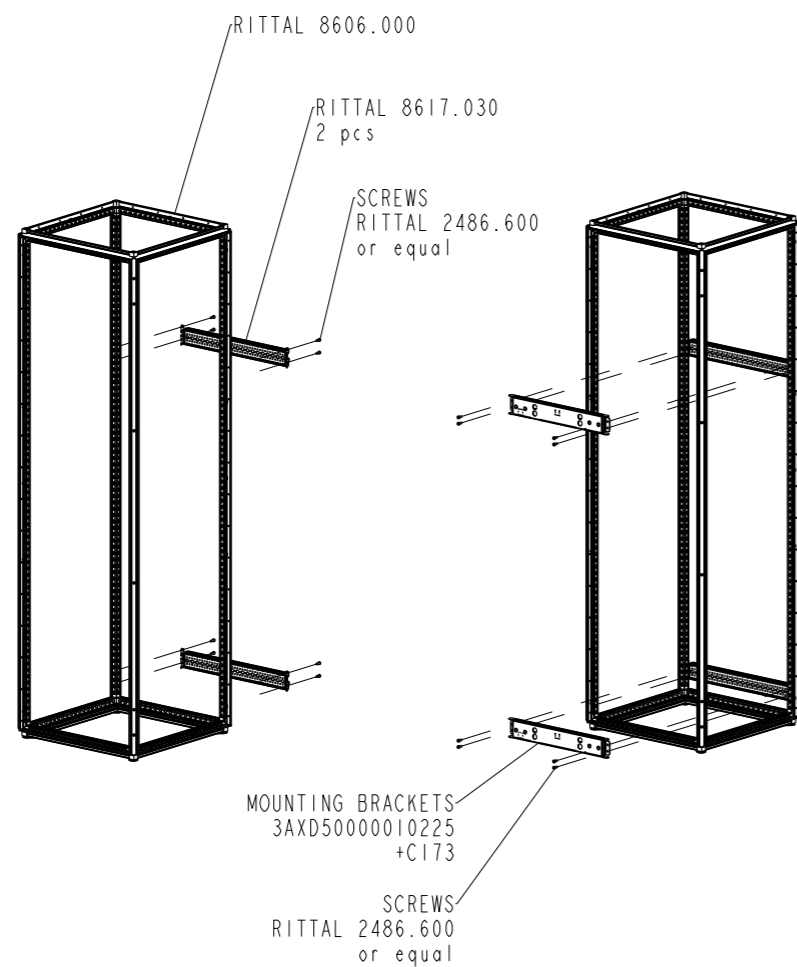

SCREWS
68310857
M10x25
2 pcs

3AXD50000440559

270 Step-by-step drawings for a flat installation example in a Rittal VX25 600 mm wide enclosure

24. Step-by-step drawings for option +H391 installation example in a Rittal VX25 600 mm wide enclosure



ABB parts for option +H391	
1	Support for back top mounting bracket
2	Handle
3	Bottom mounting bracket
ABB standard parts	
4	Lowest back cover plate
5	Back top mounting bracket

272 Step-by-step drawings for option +H391 installation example in a Rittal VX25 600 mm wide enclosure

Further information

Product and service inquiries

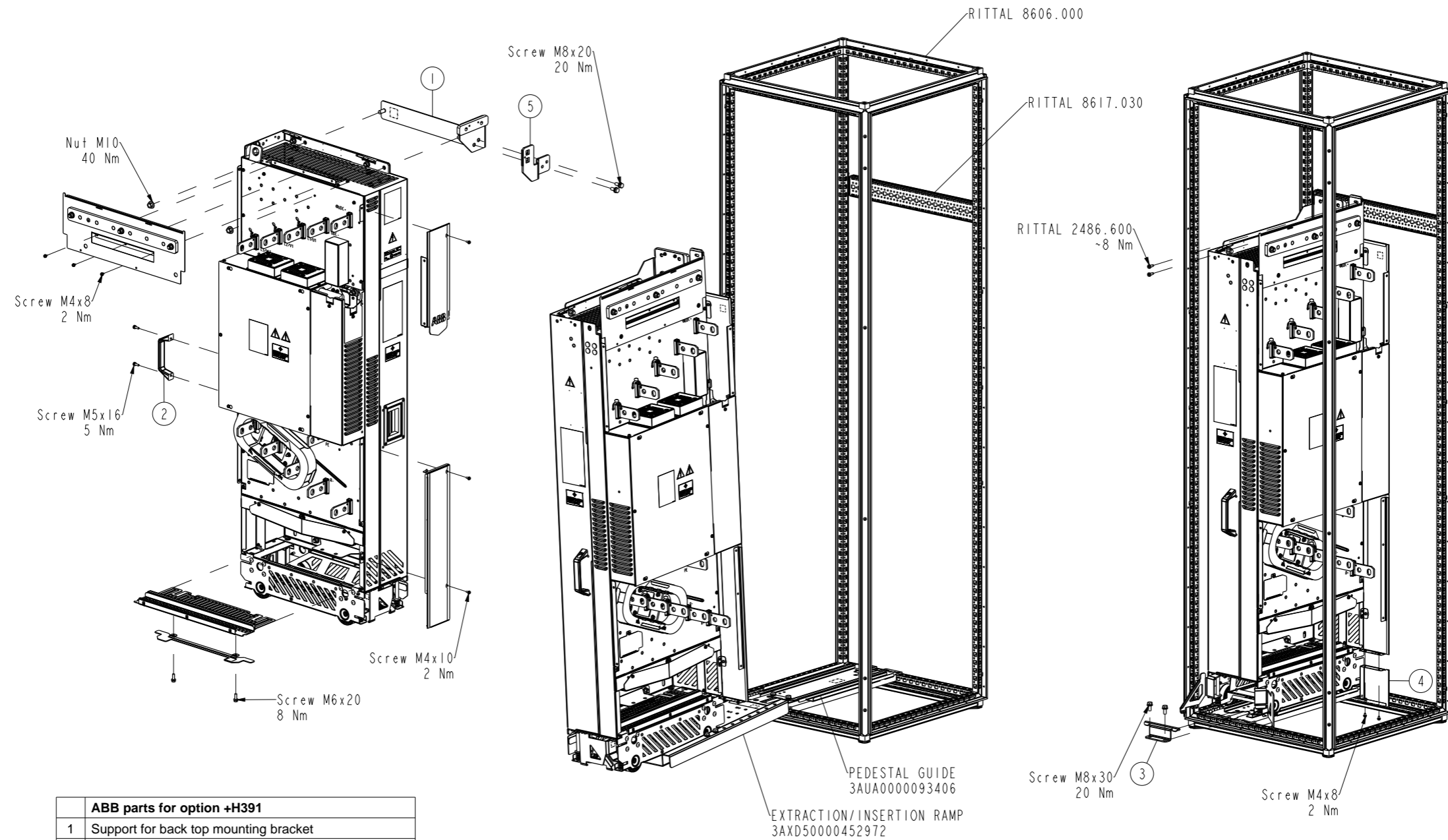
Address any inquiries about the product to your local ABB representative, quoting the type designation and serial number of the unit in question. A listing of ABB sales, support and service contacts can be found by navigating to new.abb.com/contact-centers.

Product training

For information on ABB product training, navigate to new.abb.com/service/training.

Providing feedback on ABB manuals

Your comments on our manuals are welcome. Navigate to forms.abb.com/form-26567.

Document library on the Internet

You can find manuals and other product documents in PDF format on the Internet at www.abb.com/drives/documents.



www.abb.com/drives



3AUA0000128301L