

Tmax lug kits change for T4, T5 and T8

Change notice

ABB is making improvements to its Tmax lug kits, which will bring them into alignment with the rest of ABB's global offering. The following lug kits are affected:

- KT4TN and KT4TN-4
- KT5TGD and KT5TGD-4
- K8TL and K8TM

The changes for all kits will be phased in as we deplete our present stock. Please note the following dates:

- T8 lug kit changes starting in February 2013
- T4 and T5 sizes transitioning in April 2013

During the transition period, ABB will make every effort to ship orders complete with one style. You should, however, advise customers that they may see an order with different styles of kits during this transition period.

Details for the change to each size are provided below. The changes will not affect pricing or performance of the lugs. All other lug kits will remain unaffected.

Current T4 configuration

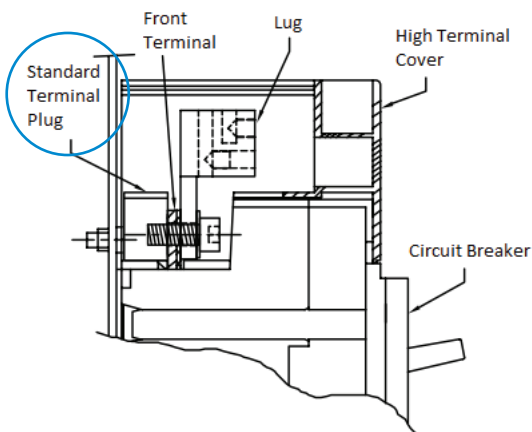

Future T4 configuration

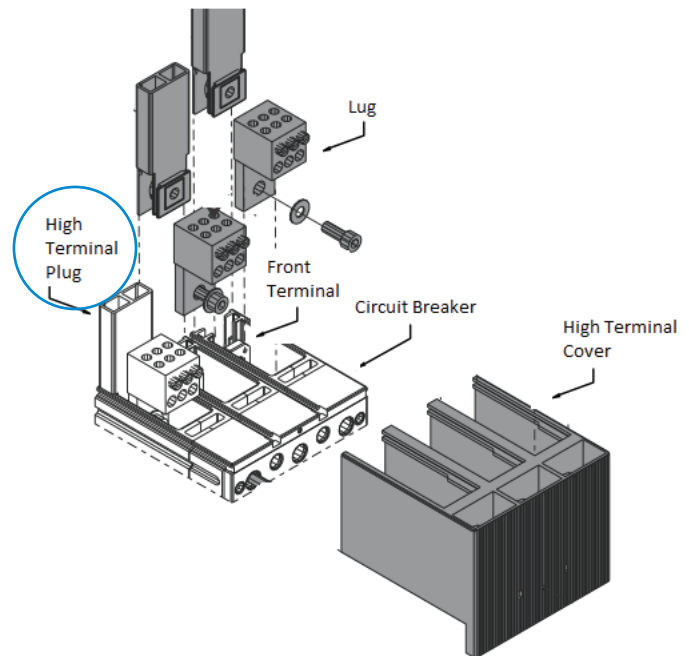

KT5TGD and KT5TGD-4

The T5 series multicable lug kits will now contain high terminal plugs as well. The high terminal plugs are to be used in place of the standard terminal plugs that are supplied with the circuit breaker and were previously used for this configuration. In addition, the screw used to fix the lug to the breaker will be changed from an 8mm head screw affixed from the front to a 7mm head screw affixed from the back.

Current T5 configuration

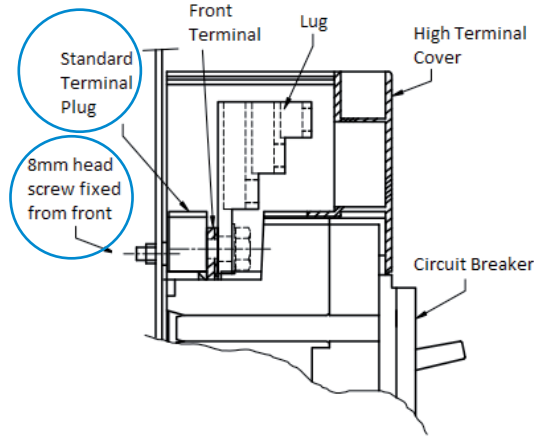

Future T5 configuration

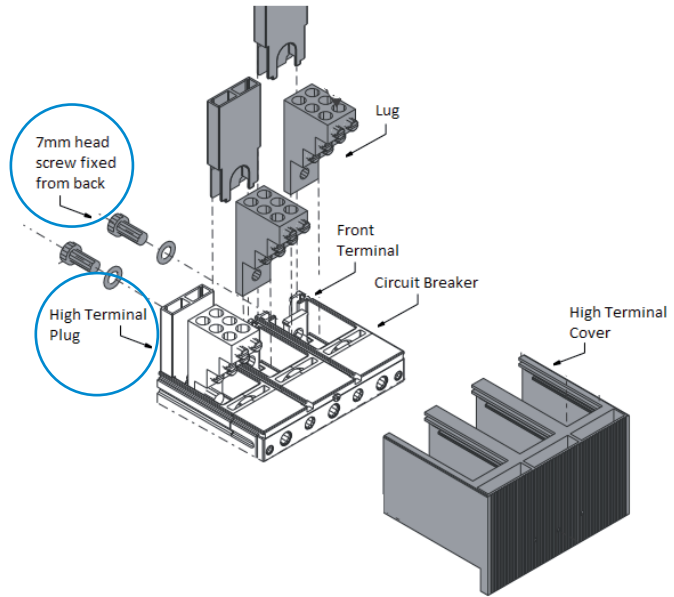

K8TL and K8TM

The T8 kits will now contain large phase separators and a cut out terminal strip. They are to be used in place of the standard phase separator and terminal strip that are supplied with the circuit breaker. The phase separators and terminal strip will be supplied with each kit, but are used only when installing the lugs on the top of the circuit breaker. Installation on the bottom of the breaker does not require the accessories.

Current T8 configuration

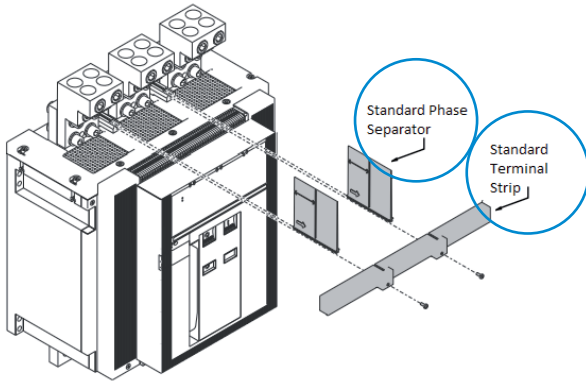

Future T8 configuration

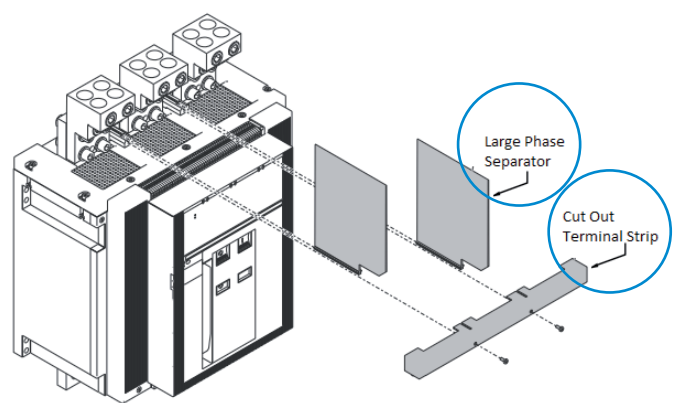

ABB Inc.

Low Voltage Products
16250 W. Glendale Drive
New Berlin, WI 53151

Technical Support & Customer Service
Phone: 888-385-1221, Option 4
Email: lvps.support@us.abb.com
Web: www.abb.us/lowvoltage