

FRONT VIEW

SIDE VIEW

ISOMETRIC VIEW

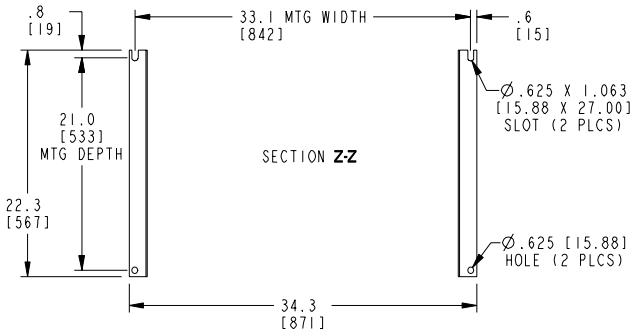
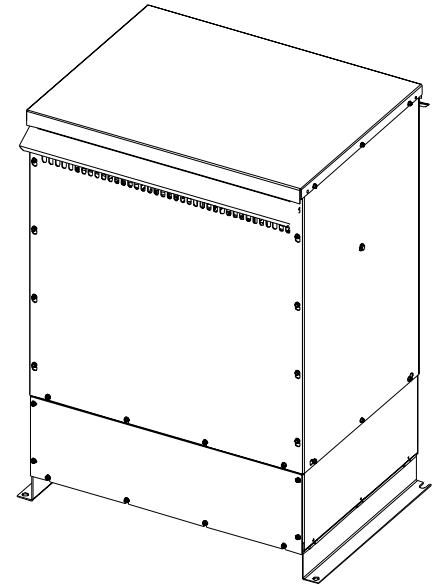
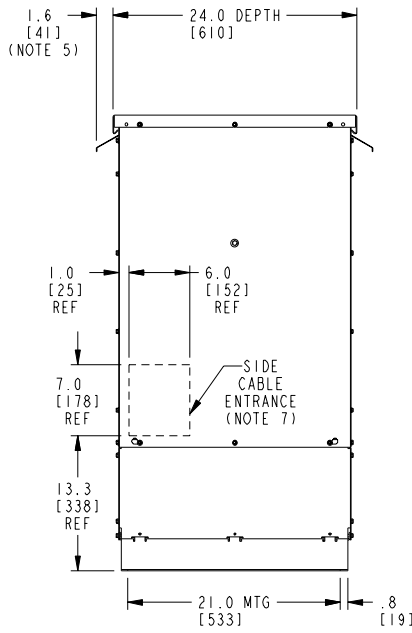
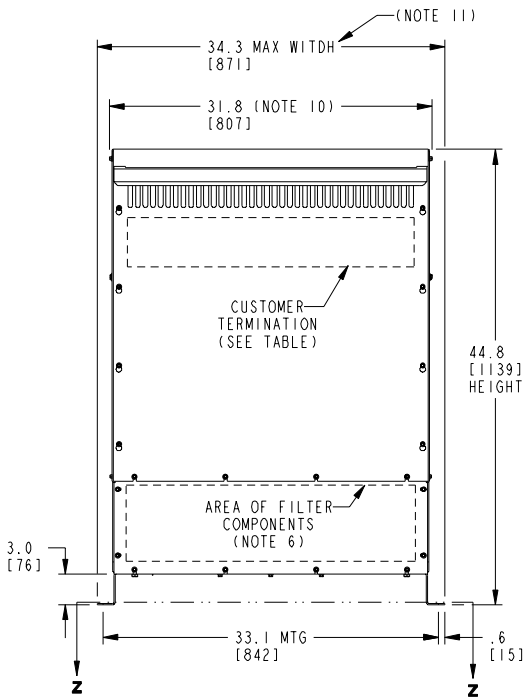

BOTTOM VIEW OF MOUNTING HOLE PATTERN

CUSTOMER TERMINATION			
LOCATION	CONNECTION TYPE	HOLE SIZE	HOLE QTY
PRIMARY BUS BARS	STANDARD BUS BAR (LUGS ARE OPTIONAL)	.40 [10.2] DIA	2 PER BUS BAR
SECONDARY BUS BARS			

APPROX TOTAL WEIGHT LBS [KG]
AL WINDINGS: 680 [308]
CU WINDINGS: 770 [349]

kVA RATING:
K-FACTOR:
PRI VOLTAGE:
SEC VOLTAGE:
FREQ (Hz):
TEMP RISE:
WINDING MATL:
ES SHIELD:
SOUND LVL (dB):

NOTES:

- 1) ALL UNITS ARE UL LISTED AND ARE DESIGNED PER NEMA ST-20 STANDARDS.
- 2) THE TEMPERATURE RISE LISTED IS DETERMINED WHEN THE TRANSFORMER IS MOUNTED IN A STANDARD NEMA-2 ENCLOSURE.
- 3) TRANSFORMER IS DESIGNED FOR FLOOR MOUNTING. OPTIONAL WALL MOUNTING BRACKETS ARE AVAILABLE.
- 4) TRANSFORMER IS DRY TYPE, CLASS AA, WITH VENTILATED ENCLOSURE FOR INDOOR USE. OPTIONAL RAIN SHIELD KITS ARE AVAILABLE TO ADAPT UNIT FOR TYPE 3R OUTDOOR USE WITHOUT VOIDING THE WARRANTY.
- 5) APPLICABLE WHEN OPTIONAL RAIN SHIELDS ARE INSTALLED. RAIN SHIELDS ARE SHIPPED IN KITS FOR FIELD INSTALLATION.
- 6) ALL UNITS INCLUDE CAPACITORS, MOV'S AND FUSES IN COMBINATION WITH ELECTROSTATIC SHIELDS.
- 7) CABLE ENTRANCE SHOULD BE THROUGH THE SIDE ENCLOSURE PANEL ONLY. CABLE ENTRANCE THROUGH THE BOTTOM IS NOT RECOMMENDED DUE TO THE POSSIBLE INTERFERENCE WITH FILTER COMPONENTS THAT ARE LOCATED IN THE LOWER COMPARTMENT.
- 8) FOR LIFTING OTHER THAN WITH A FORK TRUCK, REMOVE TOP COVER AND USE 1" [25 MM] DIAMETER HOLES IN THE TOP CORE CLAMPS.
- 9) ENCLOSURE PAINT COLOR IS ANSI #61 GRAY.
- 10) 6" [152 MM] MINIMUM CLEARANCE IS REQUIRED FROM ALL WALLS.
- 11) USE THIS DIMENSION WHEN PLANNING THE MOUNTING PAD.

JOB NAME:

UNLESS OTHERWISE SPECIFIED
 ALL DIMENSIONS ARE INCH [MM]

THIRD ANGLE PROJECTION

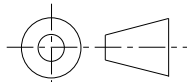

DRY TYPE TRANSFORMER OUTLINE DRAWING
TYPE QL, GUARD-II, 3-PHASE
(ENCLOSED UNIT)

electrification.us.abb.com

CAD DRAWING: 303A403AAP074

SHEET 1 OF 2

CATALOG #

REV **9**

FRONT VIEW

SIDE VIEW

ISOMETRIC VIEW

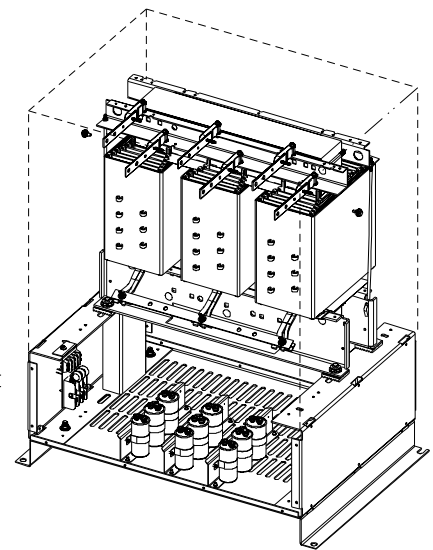
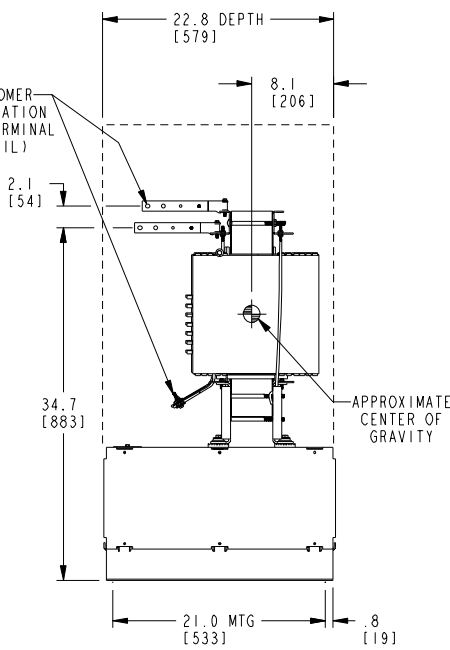
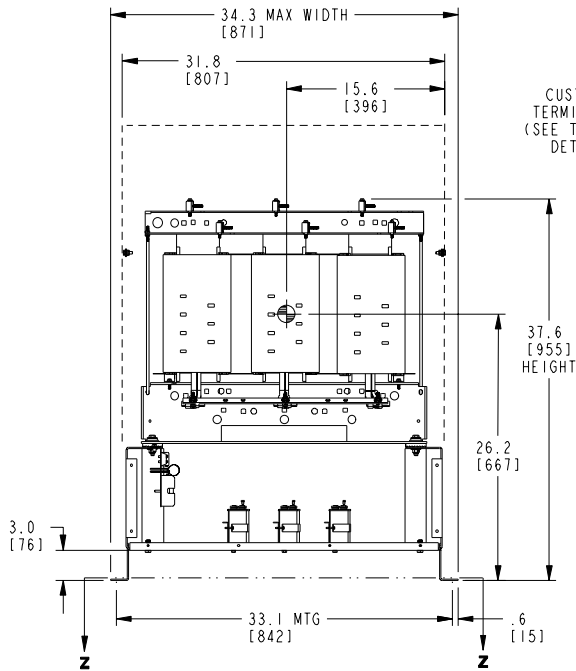

TERMINAL DETAIL

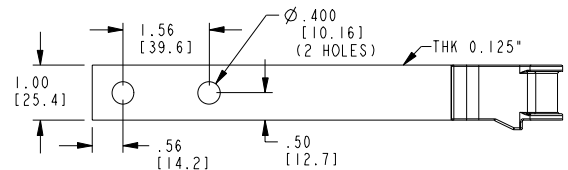

X's & H's TERMINAL

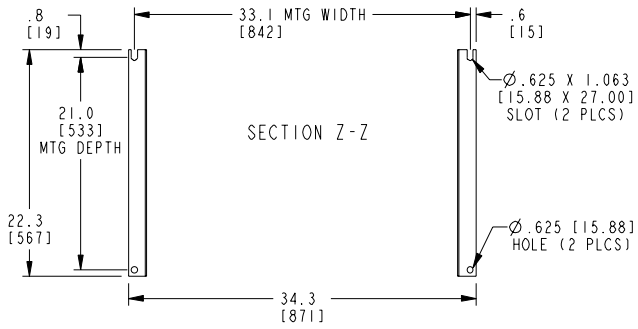
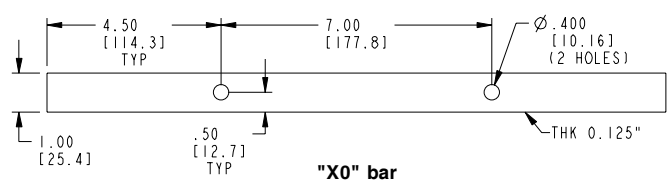

BOTTOM VIEW OF MOUNTING HOLE PATTERN

CONNECTION TYPE: STANDARD BUS BAR (LUGS ARE OPTIONAL).

APPROX TOTAL WEIGHT LBS [KG]
AL WINDINGS: 680 [308]
CU WINDINGS: 770 [349]

kVA RATING:
K-FACTOR:
PRI VOLTAGE:
SEC VOLTAGE:
FREQ (Hz):
TEMP RISE:
WINDING MATL:
ES SHIELD:
SOUND LVL (dB):

NOTES:

- 1) ALL UNITS ARE UL LISTED AND ARE DESIGNED PER NEMA ST-20 STANDARDS.
- 2) THE TEMPERATURE RISE LISTED IS DETERMINED WHEN THE TRANSFORMER IS MOUNTED IN A STANDARD NEMA-2 ENCLOSURE.
- 3) TRANSFORMER IS DESIGNED FOR FLOOR MOUNTING. OPTIONAL WALL MOUNTING BRACKETS ARE AVAILABLE.
- 4) TRANSFORMER IS DRY TYPE, CLASS AA, WITH VENTILATED ENCLOSURE FOR INDOOR USE. OPTIONAL RAINSHIELD KITS ARE AVAILABLE TO ADAPT UNIT FOR TYPE 3R OUTDOOR USE WITHOUT VOIDING THE WARRANTY.
- 5) ALL UNITS INCLUDE CAPACITORS, MOV'S AND FUSES IN COMBINATION WITH ELECTROSTATIC SHIELDS.
- 6) CABLE ENTRANCE SHOULD BE THROUGH THE SIDE ENCLOSURE PANEL ONLY. CABLE ENTRANCE THROUGH THE BOTTOM IS NOT RECOMMENDED DUE TO THE POSSIBLE INTERFERENCE WITH FILTER COMPONENTS THAT ARE LOCATED IN THE LOWER COMPARTMENT.
- 7) FOR LIFTING OTHER THAN WITH A FORK TRUCK, REMOVE TOP COVER AND USE 1" [25 MM] DIAMETER HOLES IN THE TOP CORE CLAMPS.
- 8) ENCLOSURE PAINT COLOR IS ANSI #61 GRAY.
- 9) 6" [152 MM] MINIMUM CLEARANCE IS REQUIRED FROM ALL WALLS.
- 10) ⊕ INDICATES APPROXIMATE CENTER OF GRAVITY.

JOB NAME:

UNLESS OTHERWISE SPECIFIED
 ALL DIMENSIONS ARE INCH [MM]

THIRD ANGLE PROJECTION

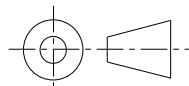

**DRY TYPE TRANSFORMER OUTLINE DRAWING
 TYPE QL, GUARD-II, 3-PHASE
 (VIEWS WITHOUT ENCLOSURE PANELS)**

electrification.us.abb.com

CAD DRAWING: 303B403AAP074

SHEET 2 OF 2

CATALOG #

REV **9**