

BROCHURE

## Slip ring motors

ABB expertise provides the best solutions to drive the industry



- Slip-ring motors are an ideal solution for applications which require high starting torque and low starting current
- They are especially suitable for heavy load inertia applications like mill drives or situations where network conditions are weak

---

We provide motors, generators and mechanical power transmission products, services and expertise to save energy and improve customers' processes over the total life cycle of our products, and beyond.





# The most innovative technology for motors and drives

## More than 125 years of experience for forward-looking products

ABB's wound rotor motors are best suited to the most demanding applications.

Where a high starting torque is required or a high inertia load needs to be started, then ABB's slip ring motors are the right choice allowing successful operation on weak networks with their very low starting current demand.

These motors can also be matched to variable speed drives and can provide a high torque output throughout the entire speed range.

Building on over 125 years' of design experience and application expertise, ABB is one of the world's leading manufacturers of high-voltage wound rotor induction motors.

Today our products are widely used within building material industries in the Cement, Mining and Minerals industries, but they are best suited to pumps in Water Utilities and Water Works.

Our unrivaled manufacturing heritage and track record of building close partnerships with our customers offers you a genuine competitive advantage. At the same time, by continuously developing and incorporating the most advanced design, analysis and manufacturing technologies for all components, we also optimize your operating efficiency and ensure total reliability.

These carefully designed and ruggedly constructed motors with fully braced and vacuum pressure impregnated (VPI) Stator and rotor windings are made for heavy-duty operation. The very high efficiency level of ABB's wound rotor motors is mainly achieved by the effective use of high-quality materials, advanced ventilation technology, and the most sophisticated computer programs for motor design.

This high efficiency level enables considerable energy savings during the entire lifetime of the motor and reduced cost of ownership.

### **ABB premium quality includes and is not limited to:**

- High efficiency levels
- Low operating noise
- Long lifetime with reduced maintenance
- VPI insulation system Micadur Compact Industry®
- Modern and rugged design
- Over 125 years' experience in rotating machines
- Global ABB sales network
- Global ABB service network
- Global production footprint
- ISO9001 quality certification
- ISO14000 environmental certification



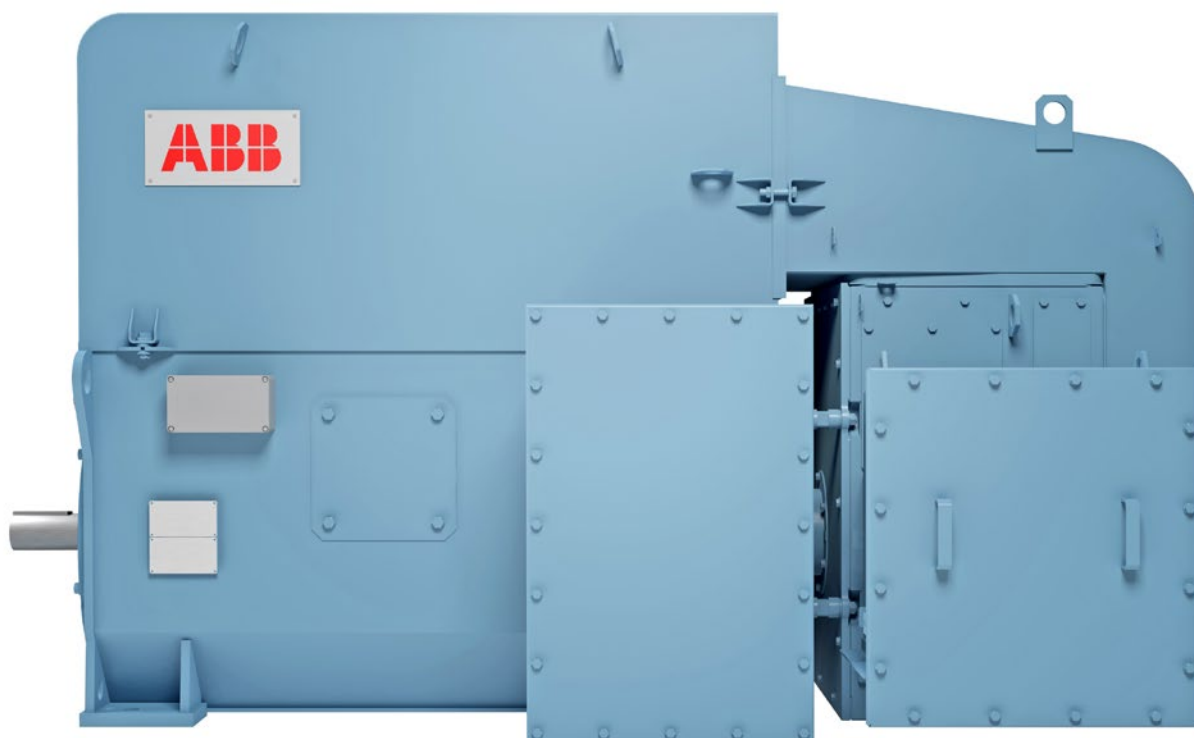

### Slip ring motor, type NMK

#### Technical specifications

Output power	up to 10.000 kW
Frame sizes	400, 450, 500, 560, 630, 710
Number of poles	4 to 16
Voltage	2.3 to 13.8 kV
Frequency	50 Hz, 60 Hz
Cooling	IC611, IC616, IC81W, IC86W
Protection	IP55
Enclosure material	Fabricated steel
Bearings	Antifriction or sleeve
Motor type	NMK
Mounting	Horizontal
Standards	IEC (NEMA MG1 electrical design available)
Supply type	DOL
Insulation class	F 155 °C
Ex protection types	Not available

### Reliable supplier

Every customer can enjoy ABB's comprehensive research and development program which offers the latest technological advancements in both motors and drives. As a pioneer in rotating electrical machines, ABB manufactures, markets and sells electric motors and drives, boasting over 125 years' of experience in applying medium and high voltage AC machines to virtually all industries.

As a well-known and reliable supplier of electrical equipment, ABB has sales and service locations throughout the world, available to customers everywhere. Our extensive experience and resources combined with our global sales and service facilities make ABB the preferred partner of AC motors suppliers. ABB supplies both low voltage motors and high voltage induction motors.

## The rotor

ABB motors are best suited to operate in heavy conditions, driving processes in particularly critical environments requiring equally difficult work cycles. Rotors can especially be subject to external harmful vibrations that can reduce their useful lifetime.

ABB slip ring motor rotors are made of materials that can withstand these conditions ensuring low vibration levels through a solid structure and the perfect balancing of each component. Furthermore, the complete rotors are dynamically balanced at the maximum operating speed.

The shaft is built to meet all the needs deriving from the specific load and work cycles related to the operating conditions.

The Micadur Compact Industry® Insulation system and ABB special rotary VPI curing process for wound rotors minimize vibrations and ensure a lifelong stability; rigid bandages with patented structure also prevent windings from being exposed to distorting centrifugal forces.

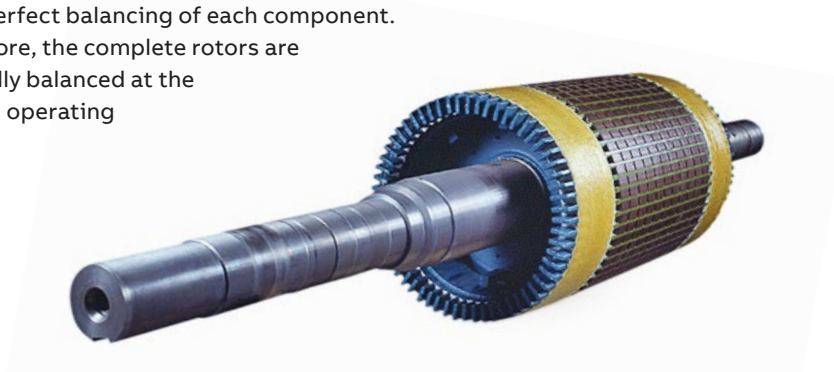

## The stator

The stator core relies on the proven and robust ABB design used in all modular induction motors. It is built in such a way as to obtain a compact and uniform system which ensures a long operating lifetime, even in particularly difficult conditions.

The radial cooling ducts allow the most efficient cooling enabling the highest power density and electrical steel sheet material with performance equivalent to a C5 plate ensures a high efficient operation.

The form wound copper coils are VPI impregnated according to the Micadur® Compact Industry insulation system, forming a single block that maintains its rigidity over the long lifetime of the machine.

The rope bracing of the coil overhangs provides an excellent support, even in the most demanding cases.

Wiring on site is simplified by the terminal boxes designed to make wire connection easier and to reduce installation time.

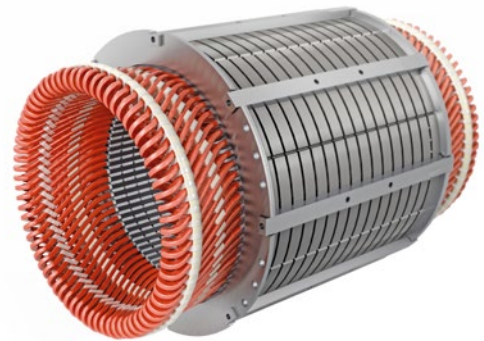

# The bearings

The bearings are an essential element for a smooth, free of vibration and low noise motor operation.

The robust bearing shields made of cast iron are designed by ABB to accommodate both antifriction and sleeve bearings, which are selected based on the motor size and various operating characteristics.

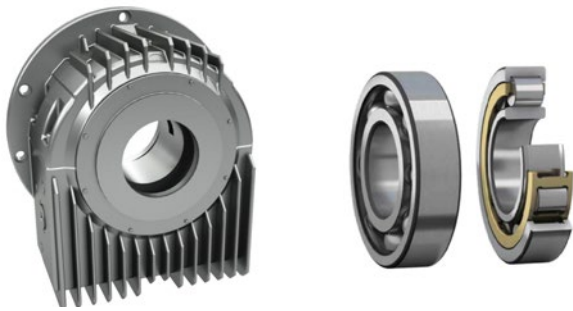

The antifriction bearings used by ABB are designed for a long operating lifetime and easy maintenance, and their structure prevents dust penetration. The sleeve bearings are of the seated, self-aligning and split type design, enabling easy replacement on site without requiring motor dismantling.

The ABB bearing design ensures a long operating lifetime and easy maintenance. According to the type of motor (from size to the various operating characteristics), bearings are available in various types as well as in the cylindrical, self-aligning or sleeve version. The antifriction bearings are designed for a 100,000-hour working lifetime and their structure minimizes noise levels and prevents dust penetration.





# Advanced slip ring unit

ABB wound rotor motors can be supplied with:

- **permanent contact brushes,** or
- **brush-lifting gear.**

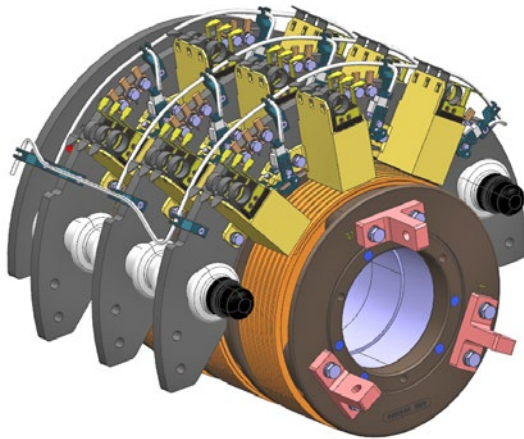

In both cases the slip rings are enclosed in a housing located at the N-end and separated from the main motor frame. This arrangement provides easy access and maintenance having openings through which the operation of the brushes can be observed, even in dark environments thanks to the installed light.

This arrangement keeps carbon dust out of the motor and offers the possibility of having different enclosures and cooling methods for the slip ring housing. Furthermore, filters are installed and these are protected by a differential pressure switch, as standard.

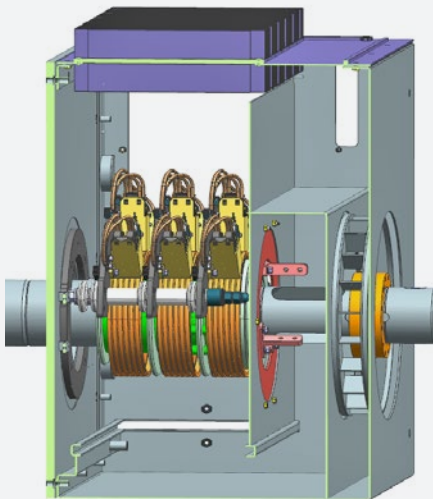

## Slip rings with permanent contact brushes

The slip rings are manufactured from a highly corrosion-resistant Cu-Sn-Ni alloy and are helical grooved to ensure uniform brush wear. An optimum current transmission is herewith achieved enabling a long brush lifetime, even for motors operating the most demanding load cycles.

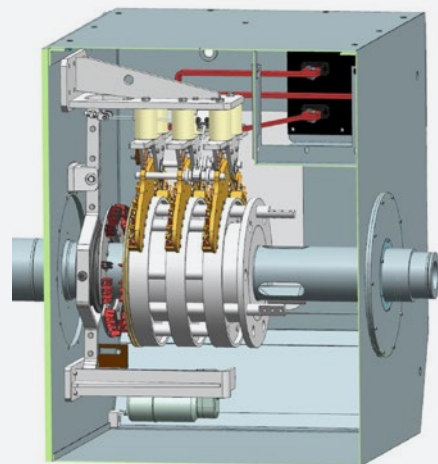

## Slip rings with brush-lifting gear

The slip rings are manufactured from stainless steel and have a smooth, non-grooved surface. Installed on motors which are designed to run non-stop for long time spans, this device integrates a brush-lifting device and a slip ring short-circuiting gear (BLG).

Once the motor has achieved its full speed after starting, the BLG first short-circuits the rotor windings and then raises the brushes from the slip rings.



# Perfect cooling

## The guarantee of safe technology

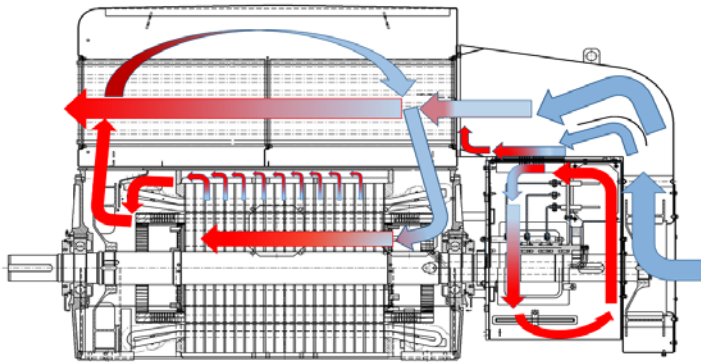

Air-to-air cooled IC611

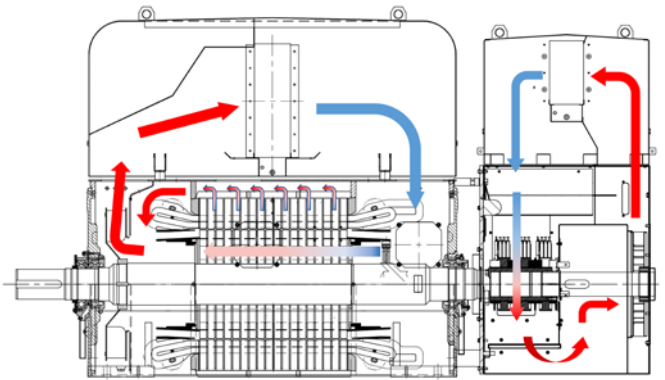

Air-to-water cooled IC81W

ABB slip ring motors can be supplied with the most common cooling arrangements, such as **air-to-air**, **air-to-water**, and air pipes using remote cooling medium. The standard cooling arrangement is always self-ventilated but, upon request, cooling by a separate blower can also be provided.

In air-to-air cooled motors, the external cooling air is circulated by a shaft mounted fan, which is located at NDE.

In both air-to-air and air-to-water cooled motors, the internal air circulation is provided as standard by a shaft mounted fan. Upon request, the internal air can also be circulated by means of a separate blower.

Motors supplied with contact slip ring brushes are equipped with a shaft-mounted fan located in-side the separate slip ring housing, and either by fins on top of the housing itself to remove the heat by the air circulated from the main fan in an air-to-air motor arrangement, or by a dedicated small air-to-water cooler for the same arrangement on the motor.

Uniform and efficient cooling of the stator and rotor is ensured by radial air ducts in both the stator and rotor core and by additional spacers between the coil ends.



# Life cycle services and support

## From pre-purchase to migration and upgrades

ABB offers a complete portfolio of services to ensure trouble-free operation and long product lifetimes. These services cover the entire life cycle. Local support is provided through a global network of ABB service centers and certified partners.



### Pre-purchase



ABB's front-end sales organization can help customers to quickly and efficiently select, configure and optimize the right motor for their application.

### Installation and commissioning



Professional installation and commissioning by ABB's certified engineers represent an investment in availability and reliability over the entire life cycle.

### Engineering and consulting



ABB's experts provide energy efficiency and reliability appraisals, advanced condition and performance assessments and technical studies.

### Condition Monitoring and Diagnosis



Unique services provide early warnings before failures occur. Data can be collected by an engineer on-site or by remote monitoring. With the ABB Ability™ platform data can be transmitted to the cloud and accessed and analyzed remotely, allowing even greater insight into the health of the equipment. The services focus on the bearings, rotor winding, stator winding insulation and overall mechanical condition.

### Maintenance and field services



ABB offers life cycle management plans and preventive maintenance products. The recommended four-level maintenance program covers the entire product lifetime.

### Spare parts



Spare parts and support are offered throughout the life cycle of ABB products. In addition to individual spares, tailored spare part packages are also available.

### Repair and refurbishment



Support for all ABB motors and other brands is provided by ABB's global service organization. Specialist teams can also deliver emergency support.

### Migration and upgrades



Life cycle audits determine the optimum upgrades and migration paths. Upgrades range from individual components to direct replacement motors.

### Training



Product and service training courses take a practical approach. The training ranges from standard courses to specially tailored programs to suit customer requirements.

### Specialized support



Specialized support is offered through ABB's global service organization. Local units provide major and minor repairs as well as overhauls and reconditioning.

### Service contracts



Service contracts are tailored to the customer's needs. The contracts combine ABB's entire service portfolio and 120 years of experience to deploy the optimal service practices.





—  
For more information, please contact  
your local ABB representative or visit

**[new.abb.com/motors-generators](http://new.abb.com/motors-generators)**

**Additional information**

We reserve the right to make technical changes or modify the contents of this document without prior notice. With regard to purchase orders, the agreed particulars shall prevail. ABB does not accept any responsibility whatsoever for potential errors or possible lack of information in this document.

We reserve all rights in this document and in the subject matter and illustrations contained therein. Any reproduction, disclosure to third parties or utilization of its contents – in whole or in parts – is forbidden without prior written consent of ABB.

© Copyright 2020 ABB. All rights reserved.  
Specifications subject to change without notice.