ABB INDUSTRIAL DRIVES

ATEX-certified motor thermal protection functions for cabinet-built ACS880 drives (options +L513+Q971 and +L514+Q971)

User's manual



ATEX-certified motor thermal protection functions for cabinet-built ACS880 drives (options +L513+Q971 and +L514+Q971)

User's manual

Table of contents



1. Safety instructions



Table of contents

1 Safety instructions

Contents of this chapter	9
Use of warnings and notes	9
ATEX/UKEX-certified motor thermal protection functions	9
Instructions for functional safety circuits	10
Electrical safety precautions	11

2 Introduction to the manual

Contents of this chapter	13
Applicability	13
Target audience	13
Exclusion of liability	14
Terms and abbreviations	14
Related manuals	15

3 ATEX-certified motor thermal protection function with PTC thermistor relays (+L513+Q971)

Contents of this chapter	17
Option description	17
Operation principle	19
Without an FSO module	19
With an FSO module	20
Implementation of the manual reset	21
Indications of the motor thermal protection function	21
PTC thermistor relays	21
ABB CM-MSS.41 thermistor motor protection relay	22
DOLD MK 9163N.12/110-ATEX thermistor relay	23
Wiring	24
Insulation of the sensor circuit	24
General wiring instructions	24
Wiring example	25
Commissioning	26
Commissioning the drive for a motor in a hazardous area	26
Validation test	27
Validation of the safety functions	27
Competence	27
Validation procedure	27
Validation test reports	27
Validation test procedure	28
Fault tracing	29
Reporting problems and failures related to safety functions	29
Technical data	29
Safety data and block diagrams	29
Without an FSO module	30
With an FSO module	30



4 ATEX-certified motor thermal protection function with Pt100 relays (+L514+Q971)

Contents of this chapter	33
Option description	33
Operation principle	35
Without an FSO module	35
With an FSO module	36
Implementation of the manual reset	37
Indications of the motor thermal protection function	37
Pt100 relays	37
GM International D5273S relay (configurable)	39
PR electronics 9116B1 universal converter relay (configurable)	40
Wiring	40
Insulation of the sensor circuit	40
General wiring instructions	40
Wiring example	42
Commissioning	43
Commissioning the drive for a motor in a hazardous area	43
Configuring the GM International D5273S relay	43
Configuring the PR electronics 9116B1 universal converter relay	45
Validation test	46
Validation of the safety functions	46
Competence	46
Validation procedure	46
Validation test reports	46
Validation test procedure	47
Fault tracing	48
Reporting problems and failures related to safety functions	48
Technical data	48
Safety data and block diagrams	48
Without an FSO module	49
With an FSO module	49

5 Parameter settings

Contents of this chapter	51
Drive / inverter	51
Switching frequency limitation	51
Reset method and status indications	51
31.22 STO indication run/stop	51
Motor overtemperature indication	52
31.11 Fault reset selection	52
Other recommended settings	53
FSO module	53
General parameters	54
Parameters for the STO function	56
Parameters for the SSE function	58
Parameters for the SS1 function	59
SS1 ramp parameters in the drive/inverter unit	60
FSE module and safety encoder parameters	61
Notes	62
Mechanical brake control	62

6 Maintenance

Contents of this chapter	63
Safety circuit maintenance	63
Proof test interval	63
Competence	64
Intentional misuse	64
Functional safety components	64
Decommissioning	64

7 Technical data

Contents of this chapter	65
The ATEX-certified motor thermal protection functions	65
PTC thermistor relays	65
ABB CM-MSS.41	65
DOLD MK 9163N.12/110-ATEX	69
Pt100 relays	71
GM International D5273S	71
PR electronics 9116B1 universal converter	73
Markings of the drive	75
Ambient conditions	75
Related standards and directives	75
ATEX certificate	77
UKEX certificate	79
Declaration of Conformity (EU)	81
Declaration of Conformity (UK)	83

Further information

1

Safety instructions

Contents of this chapter

This chapter contains the safety instructions which you must obey when you install, operate and do maintenance on the safety functions of a drive.

Use of warnings and notes

Warnings tell you about conditions which can cause injury or death, or damage to the equipment. They also tell you how to prevent the danger. Notes draw attention to a particular condition or fact, or give information on a subject.

The manual uses these warning symbols:

**WARNING!**

Electricity warning tells about hazards from electricity which can cause injury or death, or damage to the equipment.

**WARNING!**

General warning tells about conditions other than those caused by electricity, which can cause injury or death, or damage to the equipment.

**WARNING!**

Electrostatic sensitive devices warning tells you about the risk of electrostatic discharge which can cause damage to the equipment.

ATEX/UKEX-certified motor thermal protection functions

Only qualified specialists are permitted to install, control and maintain the ATEX/UKEX-certified motor thermal protection functions (see IEC/EN 60079-14).



Obey all safety regulations required with application of Ex motors in Zone 1/21 (equipment category 2) or Zone 2/22 (equipment category 2 or 3).

Instructions for functional safety circuits



WARNING!

Obey the safety instructions of the drive. If you ignore them, injury or death, or damage to the equipment can occur. If you are not a qualified electrical professional, do not do installation, commissioning or maintenance work.

This manual does not contain the complete safety instructions of the drive. It only includes the instructions related to the scope of this manual. The general instructions are given in this section and the option-specific instructions in the applicable chapter.

In addition to this manual:

- for ACS880 single drives, see the drive hardware manual
- for ACS880 air-cooled multidrives, see [ACS880 multidrive cabinets and modules safety instructions \(3AUA0000102301 \[English\]\)](#)
- for ACS880 liquid-cooled multidrives, see [ACS880 liquid-cooled multidrive cabinets and modules safety instructions \(3AXD50000048633 \[English\]\)](#).



WARNING!

The safety functions described in this manual do not isolate the main circuit or auxiliary circuit from the power supply. Do not do work on the drive, motor cable or motor before you have isolated the drive system from all power supplies and measured that there are no dangerous voltages. Before you start the work, do the electrical safety precautions in the drive safety instructions.

Electrical safety precautions

These electrical safety precautions are for all personnel who do work on the drive, motor cable or motor.

This procedure gives information on how to de-energize the drive and make it safe to do work on it. The procedure does not include all possible drive configurations. Each drive is made to order. Always refer to the circuit diagrams of the drive delivery.



WARNING!

Obey these instructions. If you ignore them, injury or death, or damage to the equipment can occur.

If you are not a qualified electrical professional, do not do installation or maintenance work.

Do these steps before you begin any installation or maintenance work.

1. Prepare for the work.
 - Make sure that you have a work order.
 - Do an on-site risk assessment or job hazard analysis.
 - Make sure that you have the correct tools available.
 - Make sure that the workers are qualified.
 - Select the correct personal protective equipment (PPE).
 - Stop the motor(s).
2. Clearly identify the work location and equipment.
3. Disconnect all possible voltage sources. Make sure that re-connection is not possible. Lock out and tag out.
 - If the drive is equipped with a DC/DC converter unit or a DC feeder unit: Open the disconnecting device of the energy storage connected to the unit. The disconnecting device is outside the drive cabinet. Then open the DC switch-disconnector ([Q11], option +F286 or +F290) of the unit.
 - Open the main disconnecting device of the drive.
 - Open the charging switch if present.
 - Open the disconnecter of the supply transformer. (The main disconnecting device in the drive cabinet does not disconnect the voltage from the AC input power busbars of the drive cabinet.)
 - Close the grounding switch or switches ([Q9], option +F259) if present. Do not use excessive force as the switch has electromagnetic interlocking.
 - Open the auxiliary voltage switch-disconnector (if present), and all other possible disconnecting devices that isolate the drive from dangerous voltage sources.
 - In the liquid cooling unit (if present), open the switch-disconnector of the cooling pumps.
 - If you have a permanent magnet motor connected to the drive, disconnect the motor from the drive with a safety switch or by other means.
 - Open the main isolating device of the drive.
 - Disconnect all dangerous external voltages from the control circuits.
 - After you disconnect power from the drive, always wait 5 minutes to let the intermediate circuit capacitors discharge before you continue.
4. Protect other energized parts in the work location against contact and take special precautions when close to bare conductors.



5. Measure that the installation is de-energized. Use a quality voltage tester. If the measurement requires removal or disassembly of shrouding or other cabinet structures, obey the local laws and regulations applicable to live working (including – but not limited to – electric shock and arc protection).
 - Before and after you measure the installation, verify the operation of the voltage tester on a known voltage source.
 - Make sure that the voltage between the drive input power terminals (L1, L2, L3) and the grounding (PE) busbar is zero.
 - Make sure that the voltage between the drive output terminals (T1/U, T2/V, T3/W) and the grounding (PE) busbar is zero.

Important! Repeat the measurement also with the DC voltage setting of the tester. Measure between each phase and ground. There is a risk of dangerous DC voltage charging due to leakage capacitances of the motor circuit. This voltage can remain charged for a long time after the drive power-off. The measurement discharges the voltage.

 - Make sure that the voltage between the drive DC busbars and the grounding (PE) busbar is zero.
 - If the drive is equipped with a DC/DC converter unit or a DC feeder unit: Make sure that the voltage between the energy storage terminals of the unit (ES+ and ES-) and the grounding (PE) busbar is zero.



WARNING!

The busbars inside the cabinet of liquid-cooled drives are partially coated. Measurements made through the coating are potentially unreliable, so only measure at uncoated portions. Note that the coating does not constitute a safe or touch-proof insulation.

6. Install temporary grounding as required by the local regulations.
 7. Ask for a permit to work from the person in control of the electrical installation work.
-



Introduction to the manual

Contents of this chapter

This chapter contains information on the manual.

Applicability

The manual is applicable to cabinet-built ACS880 single drives and multidrives with the options:

- +L513+Q971 and +2L513+Q971 (+3L513+Q971 is available on request)
- +3L514+Q971, +5L514+Q971 and +8L514+Q971 (other configurations are available on request).

The motor thermal protection functions described in this manual are certified, with a Type examination certificate, as protective systems in accordance with the ATEX (and UKEX) Product Directive.

Target audience

This manual is intended for people who install, commission, use and service the ATEX-certified motor thermal protection function of the drive. Read the manual before working on the drive. You are expected to know the fundamentals of electricity, wiring, electrical components, electrical schematic symbols, functional safety, and Ex regulations.

Exclusion of liability

ABB is not responsible for the implementation, verification and validation of the overall safety system. It is the responsibility of the system integrator (or other party) who is responsible for the overall system, Ex regulations and system safety.

The system integrator (or other responsible party) must make sure that the entire implementation complies with the instructions in this manual, all relevant standards, directives and local electrical code, and that the system is tested, verified and validated correctly.

Terms and abbreviations

Term	Description
ATEX	Directives 2014/34/EU and 1999/92/EC are commonly referred to as the ATEX directives (from "Atmosphères Explosibles")
BCU	Type of control unit
Drive	Frequency converter for controlling AC motors
Ex	An IEC term used in the context of explosive atmospheres (IEC 60079)
Ex d	Type of protection, flameproof enclosures (IEC/EN 60079-1)
Ex eb, Ex ec	Types of protection, increased safety (IEC/EN 60079-7)
Ex i	Type of protection, intrinsic safety (IEC/EN 60079-11)
Ex motors	Motors used in explosive atmospheres
FIT	Failure in time: 1E-9 hours (IEC 61508)
Frame, frame size	Physical size of the drive or power module
FSE-31	Optional pulse encoder interface module for safety encoder
FSO-21	Safety functions module which supports the FSE-31 module and the use of safety encoders
FSO-12	Safety functions module which does not support the use of encoders
HFT	Hardware fault tolerance (IEC 61508)
Inverter unit	Inverter module(s) under control of one control unit, and related components. One inverter unit typically controls one motor.
PFD_{avg}	Average probability of dangerous failure on demand (IEC 61508)
PLC	Programmable logic controller
Proof test	Periodic test performed to detect failures in a safety-related system so that, if necessary, a repair can restore the system to an "as new" condition or as close as practical to this condition. (IEC 61508, IEC 62061)
RTD	Resistance temperature detector
SAR	Safe acceleration range
SBC	Safe brake control
SIL	Safety integrity level (1...3) (IEC 61508, IEC 62061, IEC 61800-5-2)
SS1	Safe stop 1 (IEC/EN 61800-5-2)
SSE	Safe stop emergency
STO	Safe torque off (IEC/EN 61800-5-2)
Stop category	There are three categories of stop functions defined by IEC/EN 60204-1: <ul style="list-style-type: none"> • stop category 0: an uncontrolled stop where power to the machine actuators is removed immediately (for example, STO) • stop category 1: a controlled stop where the machine actuators have power for stopping, after which the power is removed (SS1) • stop category 2: a controlled stop where the machine actuators continue to have power (SS2).
T_1	Proof test interval. Defines the probabilistic failure rate (PFH or PFD_{avg}) for the safety function or subsystem. Performing a proof test at a maximum interval of T_1 is required to keep the SIL capability valid. Note that any T_1 values given cannot be regarded as a guarantee or warranty.

Term	Description
T_M	Mission time: the period of time covering the intended use of the safety function/device. After the mission time elapses, the safety device must be replaced. Note that any T_M values given cannot be regarded as a guarantee or warranty. (IEC 61800-5-2)
UCU	Type of control unit
UKEX	The Equipment and Protective Systems Intended for Use in Potentially Explosive Atmospheres Regulations 2016 (+ amendment SI 2019 No. 696)
ZCU	Type of control unit
Zone	Potentially explosive atmosphere. Hazardous areas are divided into zones, based on the frequency and duration of the occurrence of an explosive atmosphere. (IEC/EN 60079-10)

Related manuals

Manuals are available on the Internet at www.abb.com/drives/documents.

This table gives a list of related manuals.

Manual	Code
Drive hardware	
ACS880-07 drives (45 to 710 kW, 50 to 700 hp) hardware manual	3AUA0000105718
ACS880-07 drives (560 to 2800 kW) hardware manual	3AUA0000143261
ACS880-07LC drives hardware manual	3AXD50000569786
ACS880-17 drives (45 to 400 kW) hardware manual	3AXD50000035158
ACS880-17 drives (160 to 3200 kW) hardware manual	3AXD50000020436
ACS880-17LC drives hardware manual	3AXD50000250295
ACS880-37 drives (45 to 400 kW) hardware manual	3AXD50000035159
ACS880-37 drives (160 to 3200 kW) hardware manual	3AXD50000020437
ACS880-37LC drives hardware manual	3AXD50000251407
ACS880-107 inverter units hardware manual	3AUA0000102519
ACS880-107LC inverter units hardware manual	3AXD50000196111
Drive firmware	
ACS880 primary control program firmware manual	3AUA0000085967
ACS880 primary control program quick start-up guide	3AUA0000098062
PC tools	
Drive Composer start-up and maintenance PC tool user's manual	3AUA0000094606
Safety	
ACS880 multidrive cabinets and modules safety instructions	3AUA0000102301
ACS880 liquid-cooled multidrive cabinets and modules safety instructions	3AXD50000048633
Motors and drives in potentially explosive atmospheres - What you need to know	3AUA0000037223
Options	
ACS-AP-I, -S, -W and ACH-AP-H, -W Assistant control panels user's manual	3AUA0000085685
ATEX-certified motor thermal protection functions for cabinet-built ACS880 drives (options +L513+Q971 and +L514+Q971) user's manual	3AXD50000014979
FSO-12 safety functions module user's manual	3AXD50000015612
FSO-21 safety functions module user's manual	3AXD50000015614

16 Introduction to the manual

Manual	Code
FSE-31 pulse encoder interface module user's manual	3AXD50000016597

For ABB safety information and solutions, visit www.abb.com/safety. For more information about using drives and motors in potentially explosive atmospheres, visit <https://new.abb.com/drives/segments/motors-and-drives-in-potentially-explosive-atmospheres>.

3

ATEX-certified motor thermal protection function with PTC thermistor relays (+L513+Q971)

Contents of this chapter

This chapter describes the ATEX-certified motor thermal protection function (option +L513+Q971) and gives instructions on how to wire, install and start up the function. It also describes the PTC thermistor relays available for the option and gives fault tracing instructions. This chapter also contains the safety data.

Option description

This protection function monitors the temperature of a motor with PTC resistor sensors (PTC thermistors) in a potentially explosive atmosphere. The function is activated when the PTC sensor resistance exceeds the overtemperature limit. It is possible to:

- monitor the motor bearings or stator windings (+L513+Q971)
- monitor the motor bearings and stator windings (+2L513+Q971 or +3L513+Q971).

The safety function described in this manual activates the Safe torque off (STO) function of the drive when it detects motor overtemperature. The STO function of the ACS880 drives is certified (SIL 3 according to IEC/EN 61800-5-2 and IEC 61508). When activated, the STO function disables the control voltage of the power semiconductors of the drive output stage. This prevents the inverter from generating the torque required to rotate the motor. The motor coasts to a stop. For a detailed description of the STO function, see the hardware manual of your drive/inverter unit.

ACS880-07/07LC/17/17LC/37/37LC drives with option +Q978: Also the main contactor/breaker is opened.

18 ATEX-certified motor thermal protection function with PTC thermistor relays (+L513+Q971)

ACS880-07/07LC drives (frames n×DXT + n×R8i) with a main contactor/breaker (option +F250/+F255), ACS880-17/17LC/37/37LC drives (frames n×R8i + n×R8i): When the STO function is activated in the inverter unit, the main contactor/breaker is opened after a user-defined delay (defined with parameter **94.11**, the default value is 600 s). Refer to the hardware and firmware manuals for more information.

Note: If the drive has option +Q978, the main contactor/breaker is opened immediately when the STO function is activated.

Other safety functions in the drive can also use the STO function. Also, an FSO module can be included in the ATEX-certified motor thermal protection function. Refer to the circuit diagrams delivered with the drive for the actual safety circuitry.

The FSO safety functions module (FSO-12 or FSO-21) is an optional device used with ACS880 drives to implement safety functions. When installed, it reserves the standard STO connection of the drive.

The motor thermal protection function is implemented as follows:

- without an FSO module, the opening contacts of the relay(s) open the STO circuit of the drive. This activates the drive STO function.
- with an FSO module, the opening contacts of the relay(s) activate the STO or SS1 function of the FSO module. The FSO module opens the STO circuit of the drive immediately (STO, stop category 0), or after a deceleration ramp (SS1, stop category 1). This activates the drive STO function.

With an FSO module, select the stop category according to the system risk assessment.

Note: If you use a digital input (for example, DI6) for the motor overtemperature indication and set parameter **31.02** to value Fault, the drive will trip on a fault immediately when overtemperature is detected. In this case, you cannot use the SS1 function of the FSO module (stop category 1).

The protection function circuit is motor-specific. The function stops only the motor where overtemperature is detected.

It is possible to get information on the status of the protection function through a normally-open contact of the relay. The information can be obtained separately from the bearing and stator sensors. The contact can be wired to a digital input on the drive/inverter control unit or to an external control system. See the wiring instructions.

■ Operation principle

Without an FSO module

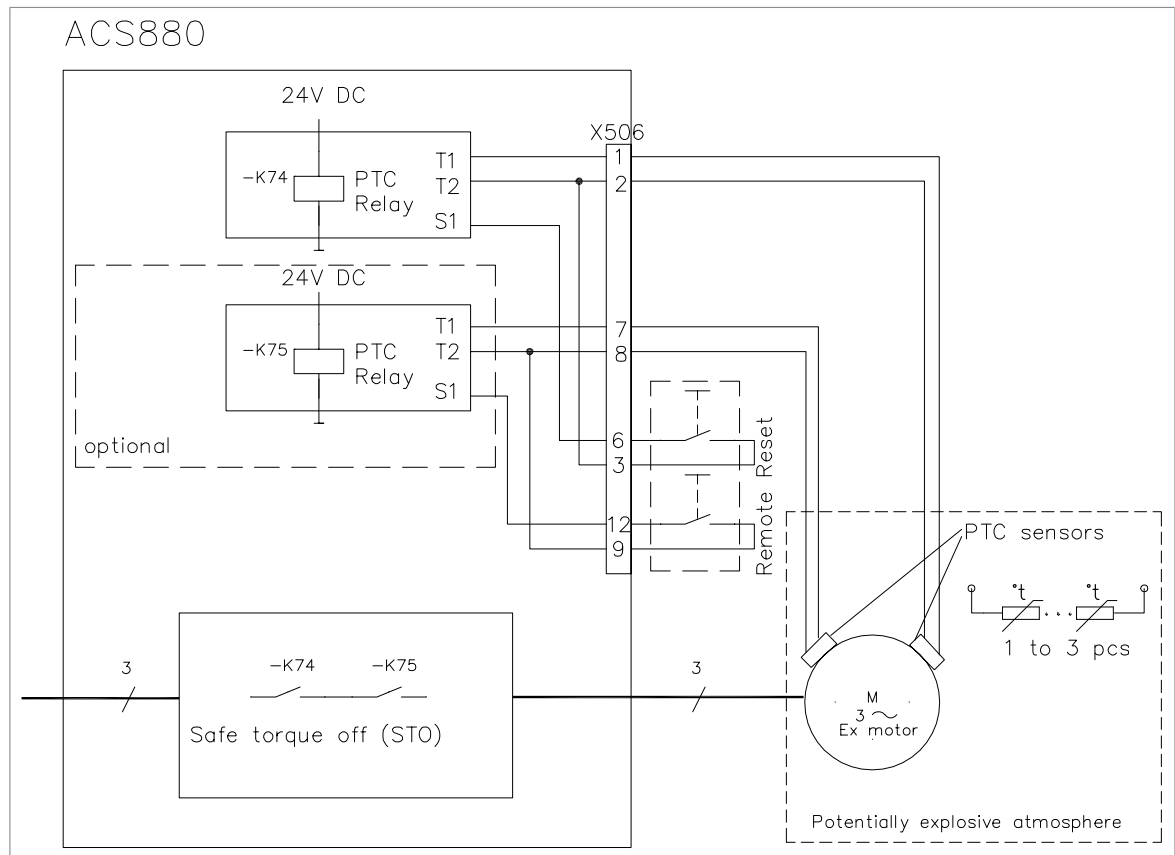

1. When the motor temperature rises to the thermistor wake-up level, the resistance of the thermistor increases sharply.
2. The PTC thermistor relay detects the change and indicates motor overtemperature through its output contacts.
3. The opening contacts of the PTC relay(s) open the STO circuit of the drive. The drive STO function is activated. This prevents the drive from generating the torque required to rotate the motor. If the motor is running, it coasts to a stop.
4. The drive generates an STO indication according to parameter 31.22.
5. If the auxiliary contacts of the PTC relays are connected to a digital input on the drive, the loss of the signal triggers a motor overtemperature indication.
6. After the motor temperature decreases to normal, the user resets the PTC relay(s) using remote reset buttons (or the buttons on the PTC relays).
Alternatively, if a manual reset of the PTC relay(s) is not used, the user resets the drive faults from the user-defined reset source (parameter 31.11), or locally with the drive control panel:
 - the STO fault in the drive (if configured with drive parameter 31.22)
 - the motor overtemperature fault in the drive (if configured).

Note: ABB recommends that you do not use the autoreset setting (that is, short-circuit the reset switch terminals of the PTC relay) with a safety device protecting an Ex motor.

With an FSO module

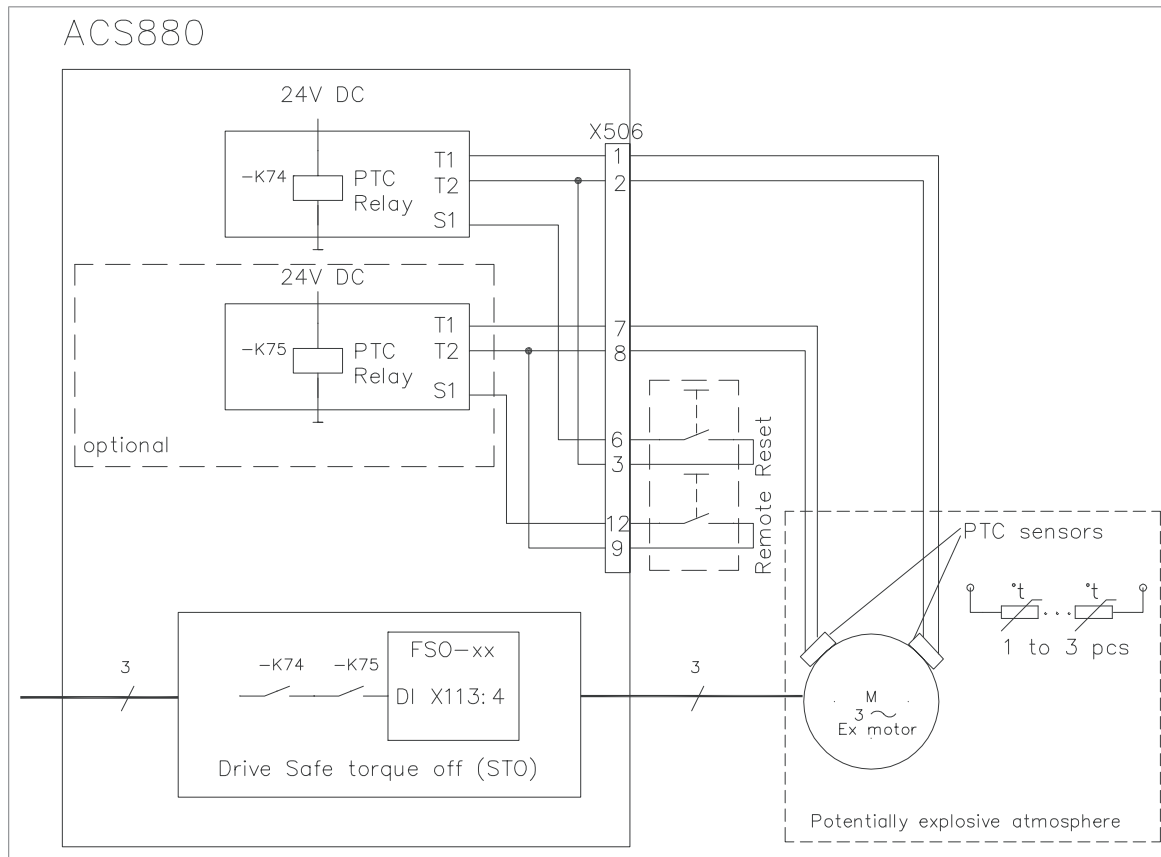

1. When the motor temperature rises to the thermistor wake-up level, the resistance of the thermistor increases sharply.
2. The PTC thermistor relay detects the change and indicates motor overtemperature through its output contacts.
3. The opening contacts of the PTC relay(s) de-energize digital input X113:4 of the FSO module (this is configured as the input of the STO or SS1 function in the FSO module).
4. If FSO is configured for STO: The FSO module opens the STO circuit of the drive immediately. The drive STO function is activated. This prevents the drive from generating the torque required to rotate the motor. If the motor is running, it coasts to a stop.
If FSO is configured for SS1: The drive decelerates the motor to zero speed (user-configurable with parameter FSOGEN.51 or FSOGEN.52). After the deceleration ramp, the drive STO function is activated. This prevents the drive from generating the torque required to rotate the motor.
5. The drive generates an STO indication according to parameter 31.22.
6. The FSO module generates an STO indication according to parameter FSOGEN.61.
7. If the auxiliary contacts of the PTC relay(s) are connected to a digital input on the drive, the loss of the signal triggers a motor overtemperature indication.
8. After the motor temperature decreases to normal, the user resets the PTC relay(s) using remote reset buttons (or the buttons on the PTC relays).

Alternatively, if a manual reset of the PTC relay(s) is not used, the user resets the drive faults from the user-defined reset source (parameter 31.11) or locally with the drive control panel:

- the STO fault in the drive (if configured with drive parameter 31.22)
- the motor overtemperature fault in the drive (if configured).

9. **Optional:** The user resets the safety function in the FSO module with the reset button (if a reset circuit is connected and configured). If the motor thermal protection function is not configured for a manual reset in the PTC relay(s) or with drive parameters, the manual reset must be implemented in the FSO module. Other safety functions in the drive can also require a manual reset in the FSO module.

Note: ABB recommends that you do not use the autoreset setting (that is, short-circuit the reset switch terminals of the PTC relay) with a safety device protecting an Ex motor.

■ Implementation of the manual reset

After the ATEX-certified motor thermal protection function activates, the motor must not restart before a manual reset command is given.

The manual reset is set in the ATEX-certified PTC thermistor relay at the factory. This complies with the ATEX/UKEX requirement on manual reset, which means that it is not necessary to configure the drive to trip on a fault. If you change the manual reset setting in the PTC thermistor relay, make sure that the user cannot restart the drive without a manual reset.

You can configure the manual reset in:

- the drive with the motor overtemperature or STO indication parameters, or
- the FSO module by connecting a reset circuit to the FSO module.

ACS880-07/07LC/17/17LC/37/37LC drives with option +Q978 or +Q979 (Emergency stop): In these safety functions, a reset circuit is connected to the FSO module and the user must reset the safety function with the emergency stop reset button. The user must also reset the ATEX-certified motor thermal protection function with the emergency stop reset button. Do not change this setting.

■ Indications of the motor thermal protection function

An indication of the safety function can come from these sources:

- the motor overtemperature indication (parameters 31.01...31.02, 35.11...35.12)
- the STO indication (parameter 31.22)
- the STO indication in the FSO module (FSO parameter FSOGEN.61).

To prevent parallel indications, you can set some indication parameters to value No indication, None or Event.

If the PTC thermistor relay is not in the manual reset mode, make sure that at least one of these indications generates a fault.

■ PTC thermistor relays

The ATEX-certified motor thermal protection function contains one (+L513) or two (+2L513) thermistor relay(s) by default. Three thermistor relays (+3L513) are available on request.

22 ATEX-certified motor thermal protection function with PTC thermistor relays (+L513+Q971)

The relay type is ABB CM-MSS.41 or DOLD MK 9163N.12/110-ATEX.

ABB CM-MSS.41 thermistor motor protection relay

Layout

	Connections	
	A1...A2	Power supply
	T1...T2	Measuring circuit with 1...3 sensors
	S1...T2	Remote reset push button switch Note: Although autoreset of the relay can be implemented by connecting these terminals together, this is not recommended when used in the protection function of an Ex motor.
	11...12/14	Output contacts (1) • 11: Common • 12: Normally-closed • 14: Normally-open
	21...22/24	Output contacts (2) • 21: Common • 22: Normally-closed • 24: Normally-open
Buttons		
	Test / Reset	Fault reset button Reset: only possible if the measured value is less than switch-on resistance. Test: only possible when there is no fault.
LEDs		
	U LED (green)	Supply voltage present
	F LED (red)	Fault message (overtemperature, broken wire, or short-circuit in the measurement circuit)
	R LED (yellow)	Output relay status

DIP switches				
Position	1	2	3	4
ON	Not in use	Not in use	Short-circuit detection de-activated	Non-volatile fault storage de-activated
OFF (default)	Not in use	Not in use	Short-circuit detection activated	Non-volatile fault storage activated

Operation diagram

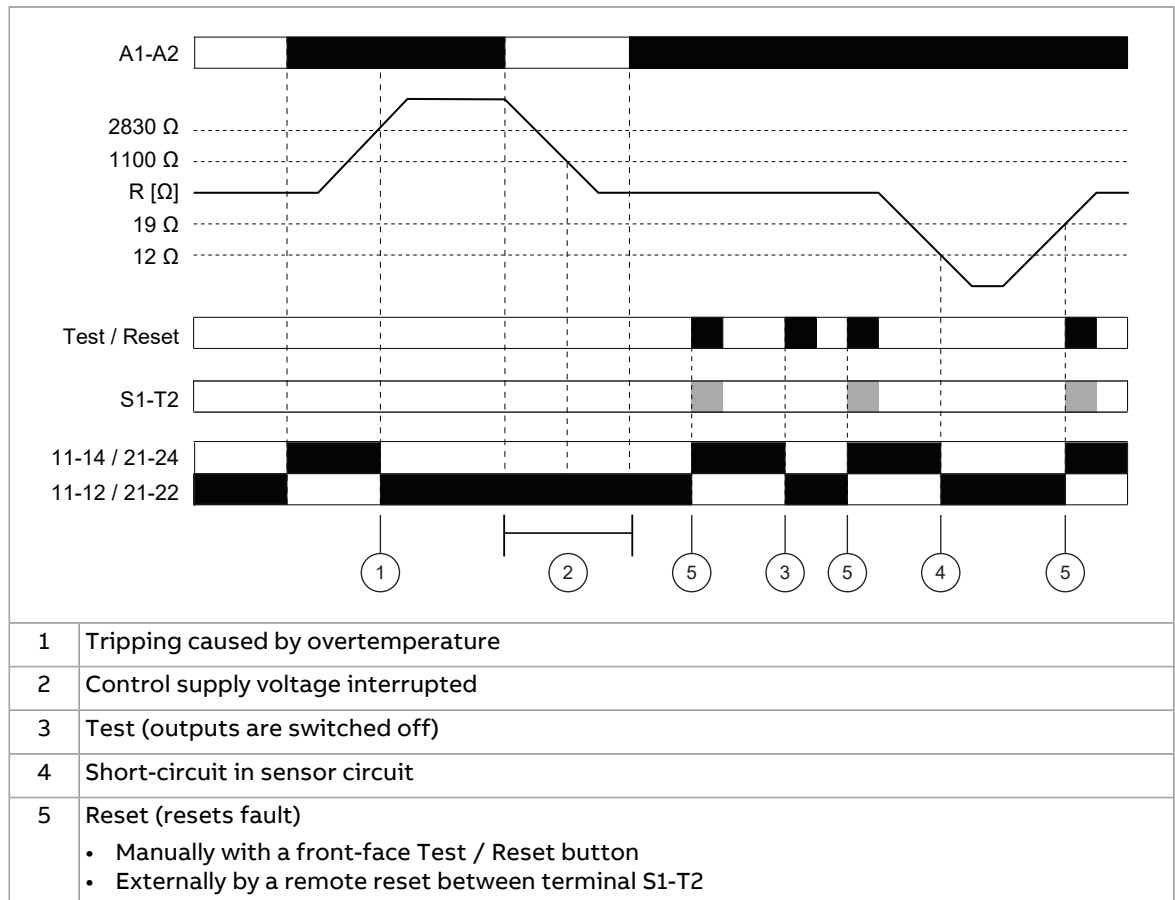

DOLD MK 9163N.12/110-ATEX thermistor relay

Layout

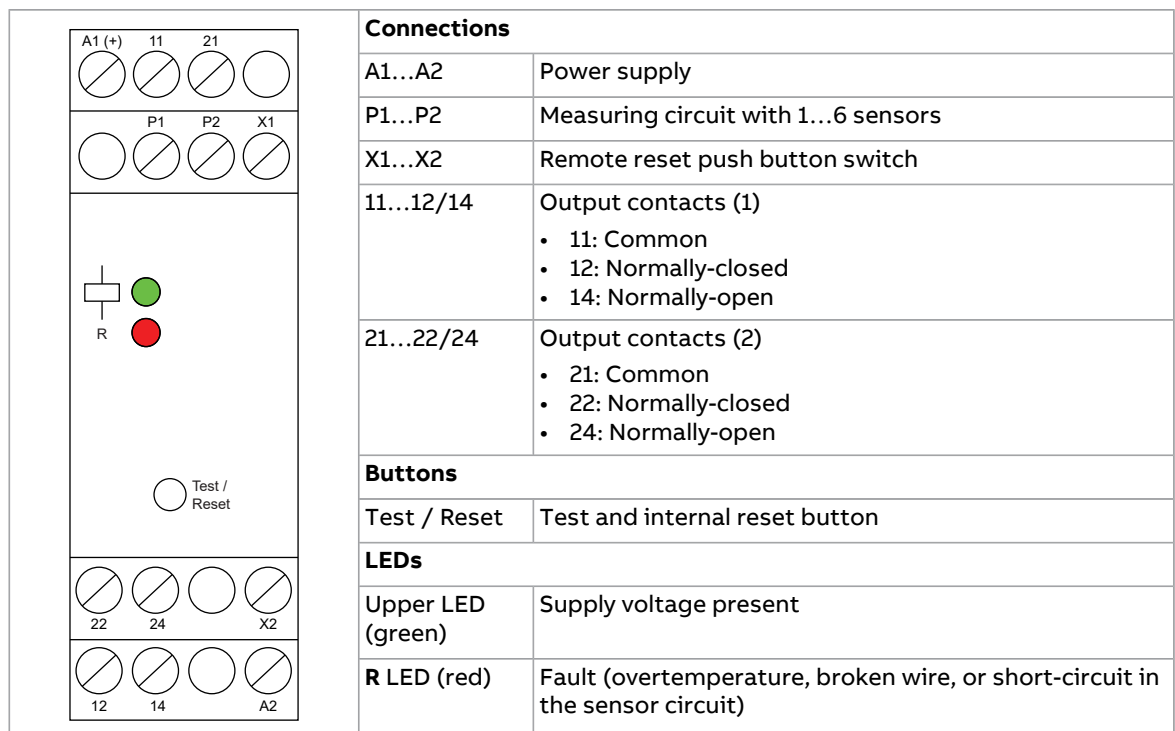

Operation diagram

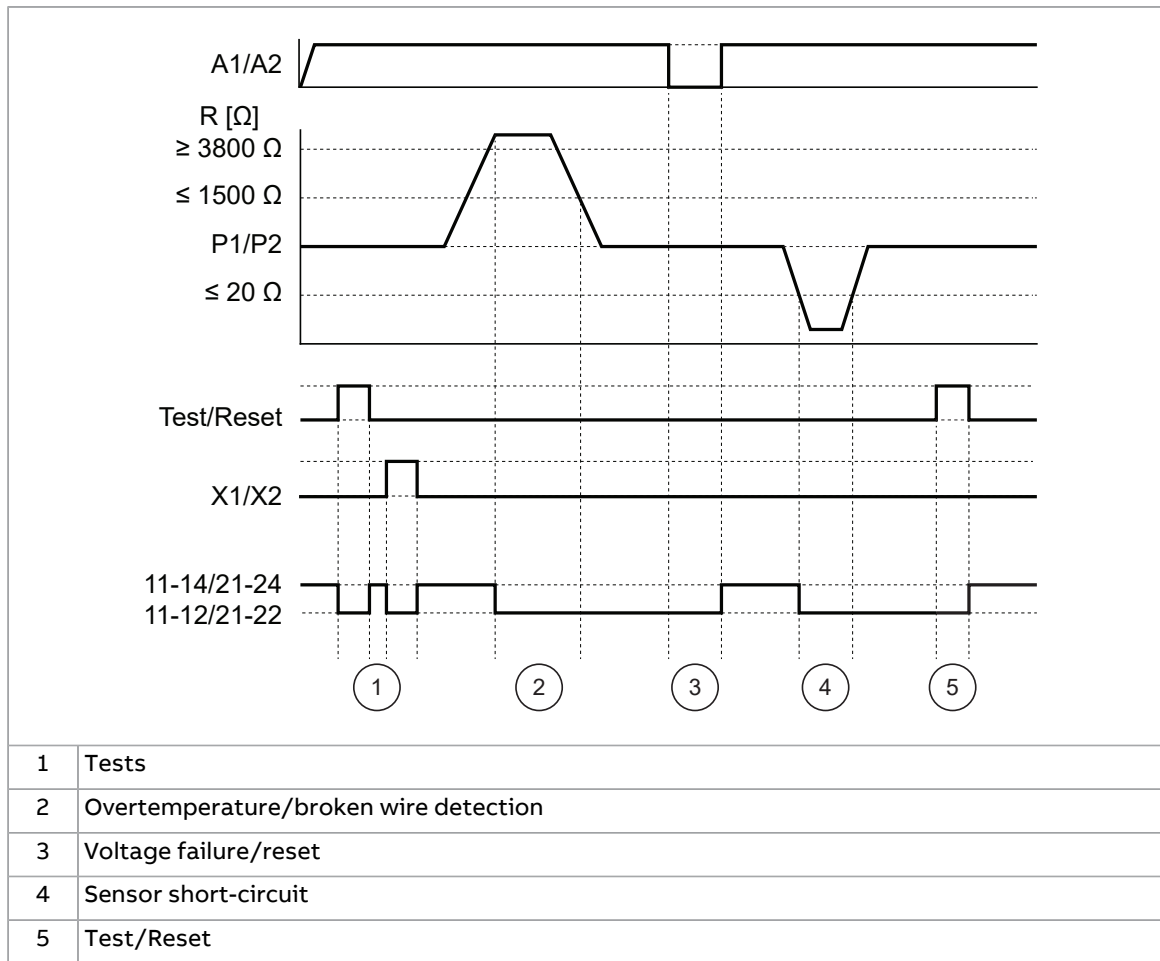

Wiring

■ Insulation of the sensor circuit

When you connect the temperature sensor(s) of the Ex motor to the drive STO terminals through a relay, make sure that there is reinforced (double) insulation between the main circuit (motor) and the drive/inverter control unit as required by IEC 61800-5-1. The insulation of the temperature sensor in the Ex motor and the insulation of the protection relay form the insulation of the whole circuit. All Ex motors manufactured by ABB have basic insulation between the main circuit and the temperature sensor.

The thermistor relays shown in this manual have basic insulation between the sensor circuit and relay output. This ensures that there is double insulation between the main circuit and the drive/inverter control unit.

■ General wiring instructions

1. Install only the sensor circuit into the potentially explosive atmosphere.
The sensor circuit in the Ex Zone must comply with the requirements for the applicable type of protection, such as:

- Ex d (IEC/EN 60079-1)
 - Ex eb (IEC/EN 60079-7, Ex e in EN 60079-7:2007 and IEC 60079-7:2006)
 - Ex ec (IEC/EN 60079-7, Ex nA in IEC/EN 60079-15:2010).
2. Install the drive or inverter unit, including the components of the ATEX-certified motor thermal protection function, outside the potentially explosive atmosphere.
 3. For the sensor connection, ABB recommends to use shielded twisted-pair cable. This type of cable decreases electromagnetic interference in the sensor circuit.
 4. Route the sensor cables away from the motor cable. Power cables can cause electromagnetic interference in the sensor circuit.
 5. Ground all sensor cable shields to a single grounding point outside the potentially explosive atmosphere. 360-degree grounding of the cable shields at the cable entry of the drive is recommended. Do not connect the cable shields to ground at the sensor end of the cable.

■ Wiring example

In this example, the PTC thermistor relay(s) are connected to digital input DI6 of the drive/inverter control unit. This connection is only for indication purposes. You can configure this digital input to give a motor overtemperature indication. For more information, refer to section [Motor overtemperature indication \(page 52\)](#).

1. Connect the PTC sensor(s) to the PTC relay(s) [K74] (and [K75], [K76], if included) through terminal block [X506]. Refer to the circuit diagrams delivered with the drive.
 2. Connect a +24 V DC source to digital input DI6 on the drive/inverter control unit [A41] through the free relay contacts on the PTC relay(s). The relay contacts are connected to terminal block [X506] at the factory. Refer to the circuit diagrams delivered with the drive and the diagram below.
 3. Connect a reset circuit to the PTC relay(s) through terminal block [X506] (recommended).
 4. With an FSO module (not shown in the figure): If FSO is configured for manual reset, connect a reset circuit to an input of the FSO module (for example, DI X113:2). In this case, step 3 is not necessary.
-

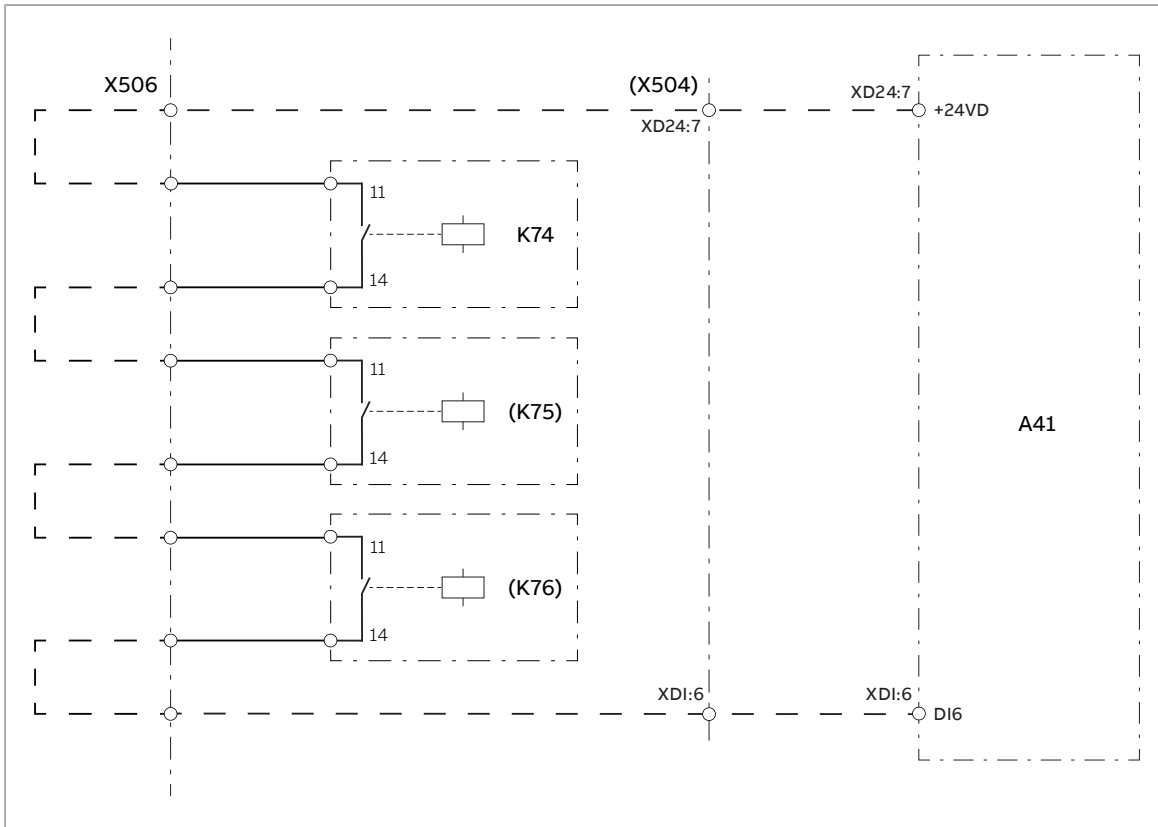

---	The dashed line in the figure shows a user-defined installation
A41	Drive/inverter control unit
K74	Thermistor relay, stator windings
K75	Thermistor relay, bearings
K76	Thermistor relay, stator windings
X504	Additional I/O terminal block (option +L504)

Commissioning

To commission the drive and the FSO module, refer to [Parameter settings \(page 51\)](#).

■ Commissioning the drive for a motor in a hazardous area

Commission the drive according to the requirements and limitations set by the application, the motor manufacturer’s instructions, drive hardware and firmware manuals, local laws and regulations, and this manual.

The certificate of the Ex motor typically requires that you set a minimum limit for the output switching frequency of the drive. Make sure that the Ex motor is operated above the minimum output switching frequency specified by the motor manufacturer.

Validation test

■ Validation of the safety functions

You must do a validation test to make sure that the safety function operates correctly and according to the safety requirements.

Competence

The person who does the validation test of the safety function must be a competent person with expertise and knowledge of the safety function and functional safety, as required by IEC 61508-1 clause 6 and Ex regulations. This person must document and sign the test procedures and report.

Validation procedure

If you use an FSO module in the safety system, you must validate the general settings of the FSO module and the safety encoder (if used) before you validate the safety function. Refer to the FSO module user's manual, chapter **Verification and validation**.

You must do the validation test using the checklist given in this manual and the validation test plan of the complete safety system:

- at the initial start-up of the safety function
- after changes related to the safety function (wiring, components, safety function-related parameter settings, etc.)
- after changes related to the power unit or its circuit boards
- after maintenance work related to the safety function
- at the proof test of the safety function.

The validation test must include at least the following steps:

- you must have a validation test plan
- you must test all commissioned functions for correct operation, from each operation location
- you must document all validation tests
- you must sign and store the validation test report for further reference.

Validation test reports

You must store the signed validation test reports in the logbook of the machine and in the explosion protection document under the scope of the ATEX User Directive 1999/92/EC or The Dangerous Substances and Explosive Atmospheres Regulations 2002 (UK). The report must include, as required by the referred standards:

- a description of the safety application (including a figure)
 - a description and revisions of safety components that are used in the safety application
 - a list of all safety functions that are used in the safety application
 - a list of all safety-related parameters and their values
-

28 ATEX-certified motor thermal protection function with PTC thermistor relays (+L513+Q971)

- documentation of start-up activities, references to failure reports and resolution of failures
- the test results for each safety function, checksums, date of the tests, and confirmation by the test personnel.

You must store any new validation test reports done due to changes or maintenance in the logbook of the machine and in the explosion protection document under the scope of the ATEX User Directive 1999/92/EC or The Dangerous Substances and Explosive Atmospheres Regulations 2002 (UK).

■ Validation test procedure

Use the Drive Composer PC tool or a control panel to do the start-up and validation test. If you use an FSO module, you must use the Drive Composer pro PC tool.

Action	<input checked="" type="checkbox"/>
 WARNING! Obey the safety instructions of the drive. If you ignore them, injury or death, or damage to the equipment can occur.	<input type="checkbox"/>
Initial status	
With an FSO-21 and FSE-31 module: If you use a safety encoder in the safety application, validate the safety encoder interface as described in FSO-21 safety functions module user's manual (3AXD50000015614 [English]) , chapter Verification and validation .	<input type="checkbox"/>
Make sure that the drive is ready for use, that is, you have done the tasks of the drive start-up procedure. See the drive hardware manual.	<input type="checkbox"/>
Make sure that the drive STO function is configured and validated. See the hardware manual.	<input type="checkbox"/>
With an FSO module: Make sure that the FSO STO function is configured and validated. Internal monitoring of the FSO module can trigger the STO function even if you have not defined an external request signal. The STO function must be validated before other safety functions. Note: If you use a safety encoder, and parameter S_ENCGEN.11 is set to Est switch not active load, both STO function with speed estimate and STO function with encoder feedback must be tested - most importantly, the value of parameter STO.14 must be set according to the application requirements.	<input type="checkbox"/>
Checks and settings with no voltage connected	
Stop the drive and do the steps in section Electrical safety precautions (page 11) before you start the work.	<input type="checkbox"/>
Make sure that the classification of the motor thermal protection function corresponds to the Ex classification of the environment and the Ex motor.	<input type="checkbox"/>
The motor manufacturer selects the PTC sensors for the motor temperature measurement. Make sure that the temperature on-off resistances match those of the PTC thermistor relay. Also make sure that there is basic or reinforced insulation between the sensor and the motor main circuit.	<input type="checkbox"/>
Make sure that the installation of PTC sensors complies with the requirements for the applicable type of protection. See section Wiring (page 24) .	<input type="checkbox"/>
Make sure that the wires are connected to the correct terminals and that the terminal connections are tightened to the correct torque.	<input type="checkbox"/>
Settings with voltage connected	
Close the cabinet doors and power up the drive. See the hardware manual.	<input type="checkbox"/>
Make sure that the parameter settings related to the safety function are correct. See chapter Parameter settings .	<input type="checkbox"/>
If necessary, configure the motor overtemperature and STO indication. See section Reset method and status indications (page 51) .	<input type="checkbox"/>

Action	<input checked="" type="checkbox"/>
If you have set the PTC relays to autoreset mode, make sure that the drive (or FSO module) is configured for a manual reset of the safety function.	<input type="checkbox"/>
Validation test procedure	
Do a short-circuit detection test: short-circuit the sensor input. It is not necessary to disconnect the sensor circuit. Make sure that: <ul style="list-style-type: none"> • the protection relay trips • the motor coasts to a stop (STO), or is decelerated to zero speed (SS1) • the drive STO is activated • the correct indications are shown. 	<input type="checkbox"/>
Do a broken wire detection test: disconnect the sensor circuit. Make sure that: <ul style="list-style-type: none"> • the protection relay trips • the motor coasts to a stop (STO), or is decelerated to zero speed (SS1) • the drive STO is activated • the correct indications are shown. 	<input type="checkbox"/>
Do an overtemperature monitoring test: increase the resistance of the sensor circuit to 4 kohm. Make sure that: <ul style="list-style-type: none"> • the protection relay trips • the motor coasts to a stop (STO), or is decelerated to zero speed (SS1) • the drive STO is activated • the correct indications are shown. 	<input type="checkbox"/>
With the relay(s) in tripped state, try to start the drive. The drive must not start before you reset the PTC relay(s) and/or the drive (and FSO) faults.	<input type="checkbox"/>
Create a backup file of the drive parameters with the Drive Composer PC tool or control panel.	<input type="checkbox"/>
<u>With an FSO module:</u> Save the FSO safety file (button Save safety file in the Drive Composer pro PC tool).	<input type="checkbox"/>
Fill in and sign the validation test report. Store the report in the logbook of the machine.	<input type="checkbox"/>

Fault tracing

For the warning and fault messages generated by the drive, see the drive firmware manual.

For the fault indication LEDs of the PTC relays, see section [PTC thermistor relays \(page 21\)](#).

For the status LEDs of the FSO module, see the FSO module user's manual.

■ Reporting problems and failures related to safety functions

Contact ABB.

Technical data

Refer to [Technical data \(page 65\)](#).

■ Safety data and block diagrams

The safety block diagrams show the components that are included in the safety data calculations.

Without an FSO module

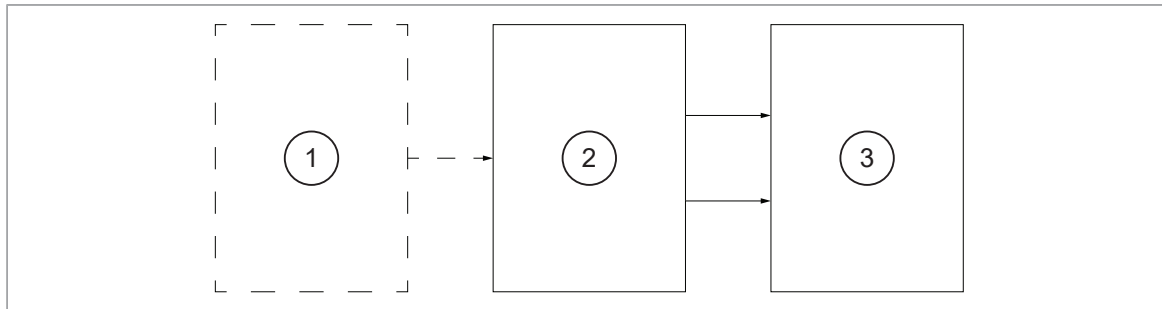

1	Customer motor PTC sensor(s)
2	Thermistor relay(s) <ul style="list-style-type: none"> • K74 • (K75) • (K76)
3	Drive STO

SIL	HFT	T ₁	PFD _{avg} (1...3 relays)
1	0	2 years	5.00E-2
3AXD10000331763 G			

Mission time (T_M) = 20 years.

With an FSO module

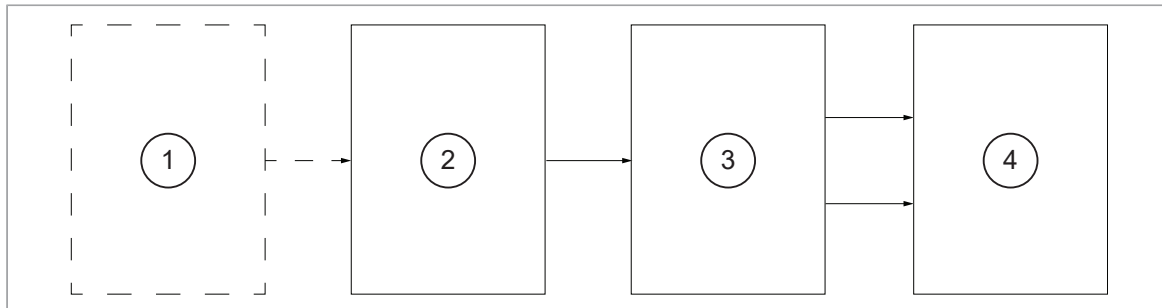

1	Customer motor PTC sensor(s)
2	Thermistor relay(s) <ul style="list-style-type: none"> • K74 • (K75) • (K76)
3	FSO module FSE module (optional) ¹⁾
4	Drive STO

¹⁾ The FSE module is included in the calculations only if:

- a safety encoder is used in the application, and
- the FSO-21 module is configured to activate the SS1 function (stop category 1) in overtemperature situations, and
- the ramp monitoring method is used in the SS1 function.

ATEX-certified motor thermal protection function with PTC thermistor relays (+L513+Q971) 31

SIL	HFT	T₁	PFD_{avg} (1...3 relays)
1	0	2 years	5.01E-2
			3AXD10000331763 G

Mission time (T_M) = 20 years.

4

ATEX-certified motor thermal protection function with Pt100 relays (+L514+Q971)

Contents of this chapter

This chapter describes the ATEX-certified motor thermal protection function (option +L514+Q971) and gives instructions on how to wire, install and start up the function. It also describes the Pt100 relays available for the option and gives fault tracing instructions. This chapter also contains the safety data.

Option description

This protection function monitors the temperature of a motor with Pt100 sensors in a potentially explosive atmosphere. The function is activated when the motor temperature exceeds the set operating temperature limit of the Pt100 relay. It is possible to:

- monitor the motor stator windings (+3L514+Q971)
- monitor the motor bearings and stator windings (+5L514+Q971)
- monitor the motor bearings and double-monitor the stator windings (+8L514+Q971).

Other configurations are available on request.

The safety function described in this manual activates the Safe torque off (STO) function of the drive when it detects motor overtemperature. The STO function of the ACS880 drives is certified (SIL 3 according to IEC/EN 61800-5-2 and IEC 61508). When activated, the STO function disables the control voltage of the power semiconductors of the drive output stage. This prevents the inverter from generating the torque

required to rotate the motor. The motor coasts to a stop. For a detailed description of the STO function, see the hardware manual of your drive/inverter unit.

ACS880-07/07LC/17/17LC/37/37LC drives with option +Q978: Also the main contactor/breaker is opened.

ACS880-07/07LC drives (frames n×DXT + n×R8i) with a main contactor/breaker (option +F250/+F255), ACS880-17/17LC/37/37LC drives (frames n×R8i + n×R8i): When the STO function is activated in the inverter unit, the main contactor/breaker is opened after a user-defined delay (defined with parameter **94.11**, the default value is 600 s). Refer to the hardware and firmware manuals for more information.

Note: If the drive has option +Q978, the main contactor/breaker is opened immediately when the STO function is activated.

Other safety functions in the drive can also use the STO function. Also, an FSO module can be included in the ATEX-certified motor thermal protection function. Refer to the circuit diagrams delivered with the drive for the actual safety circuitry.

The FSO safety functions module (FSO-12 or FSO-21) is an optional device used with ACS880 drives to implement safety functions. When installed, it reserves the standard STO connection of the drive.

The motor thermal protection function is implemented as follows:

- without an FSO module, the opening contacts of the relay(s) open the STO circuit of the drive. This activates the drive STO function.
- with an FSO module, the opening contacts of the relay(s) activate the STO or SS1 function of the FSO module. The FSO module opens the STO circuit of the drive immediately (STO, stop category 0), or after a deceleration ramp (SS1, stop category 1). This activates the drive STO function.

With an FSO module, select the stop category according to the system risk assessment.

Note: If you use a digital input (for example, DI6) for the motor overtemperature indication and set parameter **31.02** to value Fault, the drive will trip on a fault immediately when overtemperature is detected. In this case, you cannot use the SS1 function of the FSO module (stop category 1).

The protection function circuit is motor-specific. The function stops only the motor where overtemperature is detected.

It is possible to get information on the status of the protection function through a normally-open contact of the relay. The information can be obtained separately from the bearing and stator sensors. The contact can be wired to a digital input on the drive/inverter control unit or to an external control system. See the wiring instructions.

■ Operation principle

Without an FSO module

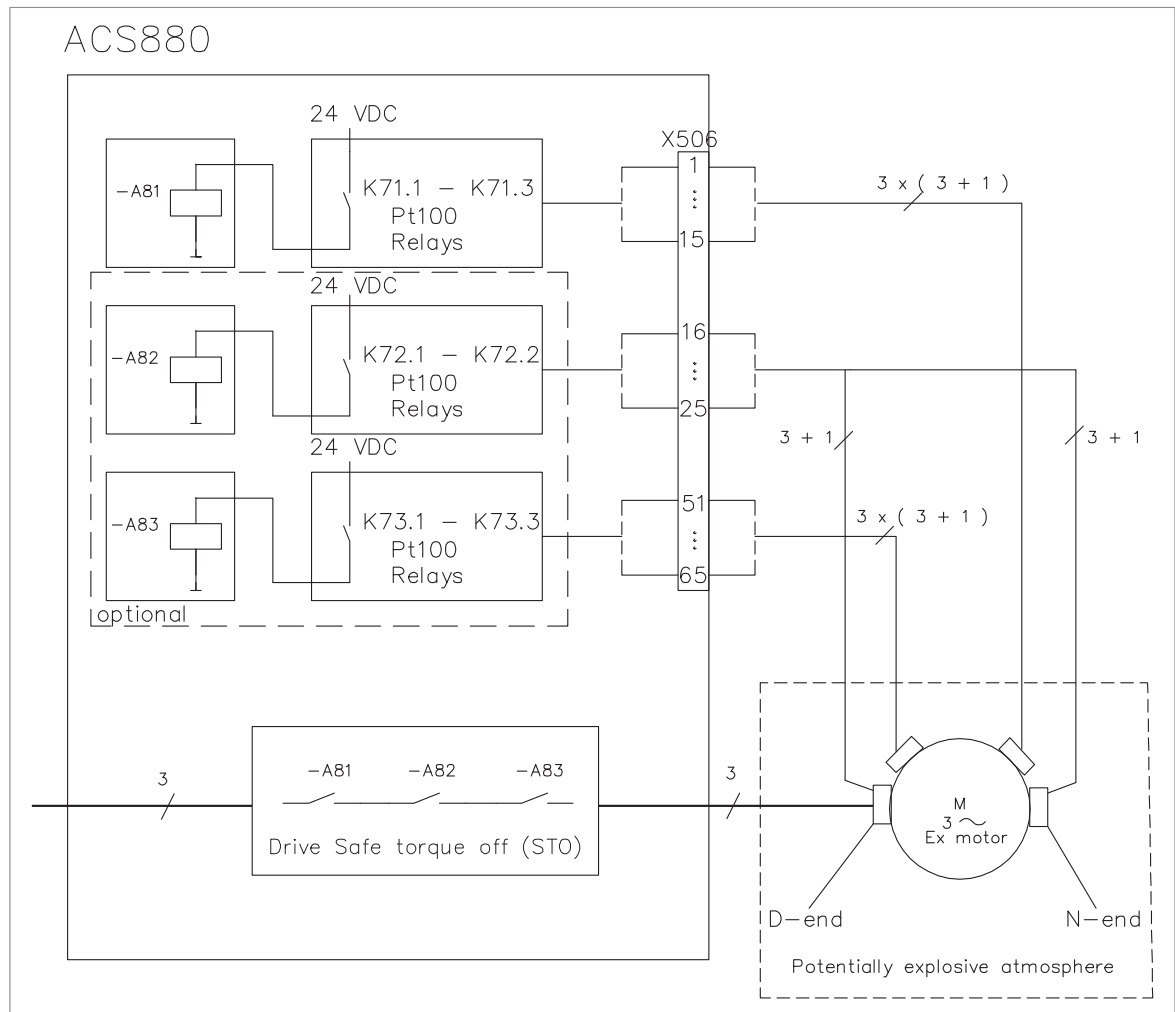

1. When the motor temperature rises, the sensor resistance increases linearly.
2. When the motor temperature exceeds the set operating temperature limit of the Pt100 relay, the relay indicates motor overtemperature through its output contacts.
3. The opening contacts of the extension relay(s) [-A81] ([-A82] and [-A83]) open the STO circuit of the drive. The drive STO function is activated. This prevents the drive from generating the torque required to rotate the motor. If the motor is running, it coasts to a stop.
4. The drive generates an STO indication according to parameter 31.22.
5. If the extension relay(s) [-A81] ([-A82] and [-A83]) are connected to a digital input on the drive, the loss of the signal triggers a motor overtemperature indication in the drive.
6. After the motor temperature decreases to normal, the Pt100 relays reset automatically.
7. The user must reset the drive faults from the reset source defined by the user (parameter 31.11) or locally with the drive control panel:
 - the STO fault in the drive (if configured with parameter 31.22)
 - the motor overtemperature fault in the drive (if configured).

With an FSO module

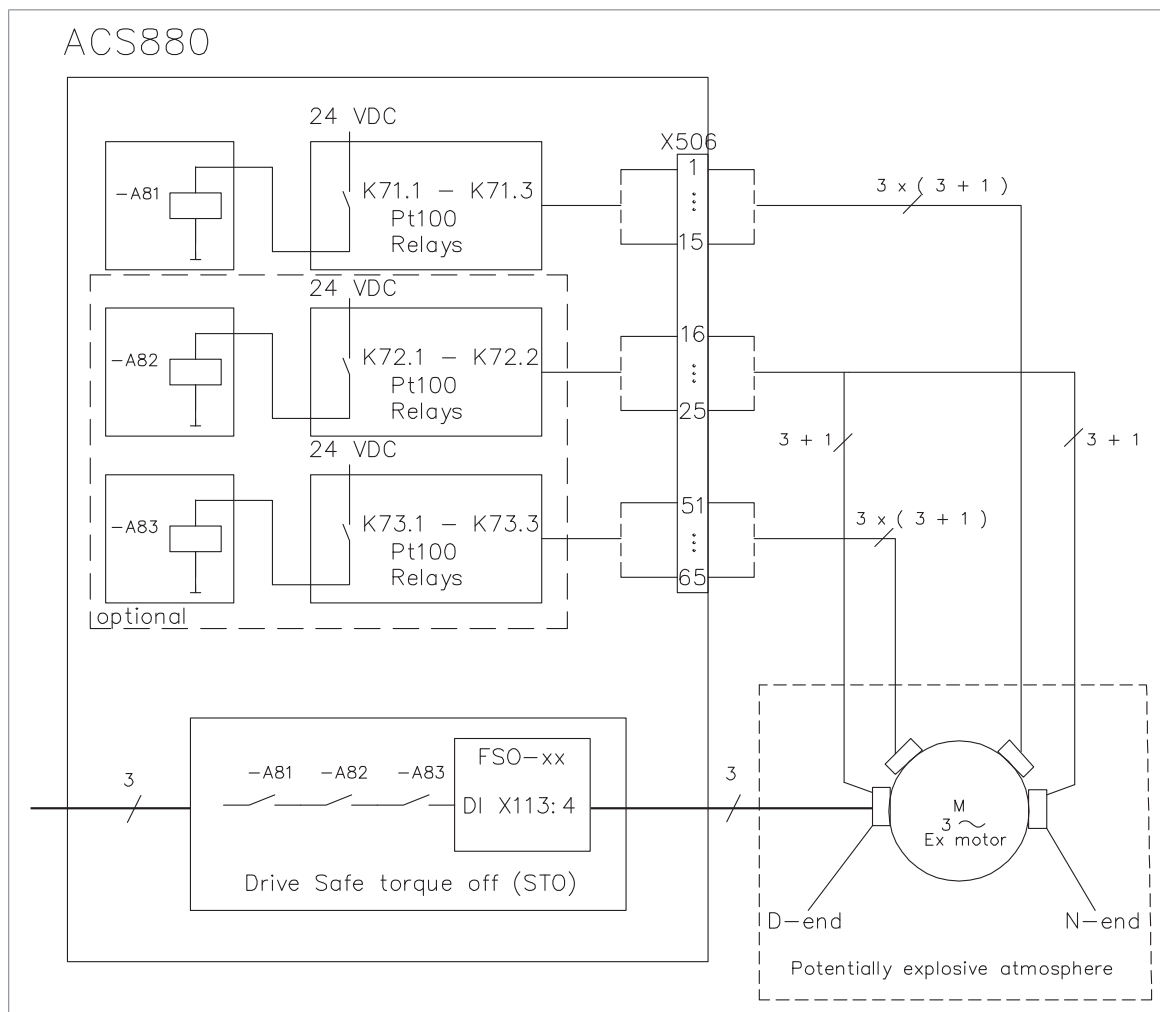

1. When the motor temperature rises, the sensor resistance increases linearly.
2. When the motor temperature exceeds the set operating temperature limit of the Pt100 relay, the relay indicates motor overtemperature through its output contacts.
3. The opening contacts of the extension relay(s) [-A81] ([-A82] and [-A83]) de-energize digital input X113:4 of the FSO module (this is configured as the input of the STO or SS1 function in the FSO module).
4. If FSO is configured for STO: The FSO module opens the STO circuit of the drive immediately. The drive STO function is activated. This prevents the drive from generating the torque required to rotate the motor. If the motor is running, it coasts to a stop.
If FSO is configured for SS1: The drive decelerates the motor to zero speed (user-configurable with parameter FSOGEN.51 or FSOGEN.52). After the deceleration ramp, the drive STO function is activated. This prevents the drive from generating the torque required to rotate the motor.
5. The drive generates an STO indication according to parameter 31.22.
6. The FSO module generates an STO indication according to parameter FSOGEN.61.
7. If the extension relay(s) [-A81] ([-A82] and [-A83]) are connected to a digital input on the drive, the loss of the signal triggers a motor temperature indication in the drive.

8. After the motor temperature decreases to normal, the Pt100 relays reset automatically.
9. The user must reset the faults from the reset source defined by the user (parameter 31.11) or locally with the drive control panel:
 - the STO fault in the drive (if configured with parameter 31.22)
 - the motor overtemperature fault in the drive (if configured).
10. Optional: If FSO is configured for manual reset, the user can reset the safety function in the FSO module with the reset button (if a reset circuit is connected and configured). In this case, step 10 is not necessary.

■ Implementation of the manual reset

After the ATEX-certified motor thermal protection function activates, the motor must not restart before a manual reset command is given.

The Pt100 relay is reset automatically. To comply with the ATEX/UKEX requirement on manual reset, make sure that the user cannot restart the drive without a manual reset.

You must configure the manual reset in:

- the drive with the motor overtemperature or STO indication parameters, or
- the FSO module by connecting a reset circuit to the FSO module.

ACS880-07/07LC/17/17LC/37/37LC drives with option +Q978 or +Q979 (Emergency stop): In these safety functions, a reset circuit is connected to the FSO module and the user must reset the safety function with the emergency stop reset button. The user must also reset the ATEX-certified motor thermal protection function with the emergency stop reset button. Do not change this setting.

■ Indications of the motor thermal protection function

An indication of the safety function can come from these sources:

- the motor overtemperature indication (parameters 31.01...31.02, 35.11...35.12)
- the STO indication (parameter 31.22)
- the STO indication in the FSO module (FSO parameter FSOGEN.61).

To prevent parallel indications, you can set some indication parameters to value No indication, None or Event.

Make sure that at least one of these indications generates a fault to ensure that the required manual reset is implemented.

■ Pt100 relays

The Pt100 relays are configurable PLCs. In addition to the operation of the motor thermal protection function, it is possible to get, for example, a 4...20 mA analog temperature signal from each Pt100 sensor.

The Pt100 relays included in the option are [Ex i] (intrinsically safe) approved associated apparatus (Ex i barrier). The installation and cabling of the protection circuit in the drive cabinet is done as intrinsically safe according to IEC/EN 60079-14 ed. 5 clause 16.

If the Pt100 sensors in the Ex Zone are not protected by an Ex type of protection (eg, Ex eb, Ex ec or Ex d), the cabling from sensors to the terminal blocks in the drive must

38 ATEX-certified motor thermal protection function with Pt100 relays (+L514+Q971)

be done as intrinsically safe [Ex i] installation. To comply with the [Ex i] requirements, use shielded or shielded twisted pair cable.

If the Pt100 sensors in the Ex Zone are protected by an Ex type of protection (eg, Ex eb, Ex ec or Ex d), the intrinsically safe [Ex i] installation and cabling are not required. If the final installation is not done as intrinsically safe [Ex i], the Ex i markings must be removed or covered from the cabinet.

The drive delivery contains a notification label, stating: Note! This sensor circuit is not executed as intrinsically safe [Ex i] installation. **If the installation is not done as intrinsically safe [Ex i], you must attach the label to the drive cabinet.**

The temperature measurement circuit of ABB motors has basic insulation. For information on the insulation of the Pt100 relay, see the applicable relay data sheet.

The option contains 3, 5, or 8 GM International D5273S relays by default. Other configurations are available on request.

PR electronics 9116B1 relays are available on request.

The option also contains 1, 2 or 3 DOLD LG 5925.48 extension relays in the Safe torque off and diagnostic circuits.

For more information on the Pt100 relays, refer to [Configuring the GM International D5273S relay \(page 43\)](#) and [Technical data \(page 65\)](#).

GM International D5273S relay (configurable)Layout

<p>Terminal block layout showing terminals 1-16 and 17-20, and LEDs: PWR (green), FLT (red), ALR A (red), ALR B (red), and CONFIG channel.</p>	Connections	
	1...3	Output contacts (Alarm 1) <ul style="list-style-type: none"> • 1: Common pole (CM1) • 2: Normally open (NO1) • 3: Normally closed (NC1)
	5...7	Output contacts (Alarm 2) <ul style="list-style-type: none"> • 5: Common pole (CM2) • 6: Normally open (NO2) • 7: Normally closed (NC2)
	9...10	Power supply
	11	+ Analog Output (source current mode) or - Analog Output (sink current mode)
	12	- Analog Output (source current mode) or + Analog Output (sink current mode)
	Measuring circuit	
	13	+ Input for thermocouple TC or for 3, 4 wire RTD or potentiometer ¹⁾
	14	- Input for thermocouple TC or for 2, 3, 4 wire RTD or potentiometer ¹⁾
	15	Input for 2, 3, 4 wire RTD or potentiometer ¹⁾
	16	Input for 4 wire RTD
	LEDs	
	PWR (green)	Supply voltage indication
	FLT (red)	Fault indication
	ALR A (red)	Alarm A
	ALR B (red)	Alarm B
Other		
CONFIG	Configuration channel	

¹⁾ Potentiometer and thermocouple TC are not used in the particular application described by this manual.

PR electronics 9116B1 universal converter relay (configurable)

Layout

	Connections	
	31...32	Power supply
	33...34	Status relay in safe area (NC). Not used in the particular application described by this manual.
	Outputs	
	11...12	Current output
	13...14	Relay output
	Inputs	
	41...44	Measuring circuit/inputs for RTD, TC, linear resistance, or potentiometer ¹⁾ <ul style="list-style-type: none"> • 41...43: 3-wire • 41...44: 4-wire
	51...54	Inputs for mA and V. Not used in the particular application described by this manual.
	LEDs	
Upper LED (green)	Operation status	
"relay" LED (yellow)	Relay status	
"error" LED (red)	Malfunction	

¹⁾ TC, linear resistance and potentiometer are not used in the particular application described by this manual.

Wiring

■ Insulation of the sensor circuit

When you connect the temperature sensor(s) of the Ex motor to the drive STO terminals through a relay, make sure that there is reinforced (double) insulation between the main circuit (motor) and the drive/inverter control unit as required by IEC 61800-5-1. The insulation of the temperature sensor in the Ex motor and the insulation of the protection relay form the insulation of the whole circuit. All Ex motors manufactured by ABB have basic insulation between the main circuit and the temperature sensor.

■ General wiring instructions

1. Install only the sensor circuit into the potentially explosive atmosphere. The sensor circuit in the Ex Zone must comply with the requirements for the applicable type of protection, such as:
 - Ex d (IEC/EN 60079-1)
 - Ex eb (IEC/EN 60079-7, Ex e in EN 60079-7:2007 and IEC 60079-7:2006)
 - Ex ec (IEC/EN 60079-7, Ex nA in IEC/EN 60079-15:2010).
2. Install the drive or inverter unit, including the components of the ATEX-certified motor thermal protection function, outside the potentially explosive atmosphere.
3. For the sensor connection, ABB recommends to use shielded twisted-pair cable. This type of cable decreases electromagnetic interference in the sensor circuit.

4. Route the sensor cables away from the motor cable. Power cables can cause electromagnetic interference in the sensor circuit.
5. Ground all sensor cable shields to a single grounding point outside the potentially explosive atmosphere. 360-degree grounding of the cable shields at the cable entry of the drive is recommended. Do not connect the cable shields to ground at the sensor end of the cable.

Note: For the motor thermal protection function with Pt100 relays, also the following types of protection for the sensor circuit are applicable:

- Ex ib (IEC/EN 60079-11)
- Ex ic (IEC/EN 60079-11).

If the installation of the sensor circuit does not comply with an applicable type of protection, obey the installation and wiring requirements for intrinsically safe (Ex i) circuits, as given in IEC/EN 60079-14 ed. 5, clause 16.

■ Wiring example

In this example, the contacts of the extension relay(s) are connected to digital input DI6 on the drive/inverter control unit. This connection is only for indication purposes. You can configure this digital input to give a motor overtemperature indication. For more information, refer to section [Motor overtemperature indication \(page 52\)](#).

1. Connect the Pt100 sensors to the Pt100 relays [K71.1...K71.3] (and [K72.1...K72.2], [K73.1...K73.3], if included) through terminal block [X506]. Refer to the circuit diagrams delivered with the drive.
2. Connect a +24 V DC source to digital input DI6 on the drive/inverter control unit [A41] through extension relay(s) [A81] (and [A82], [A83], if included). The extension relays are connected to terminal block [X506] at the factory. Refer to the circuit diagrams delivered with the drive and the diagram below.
3. With an FSO module (not shown in the figure): If necessary, connect a reset circuit to an input of the FSO module (for example, DI X113:2).

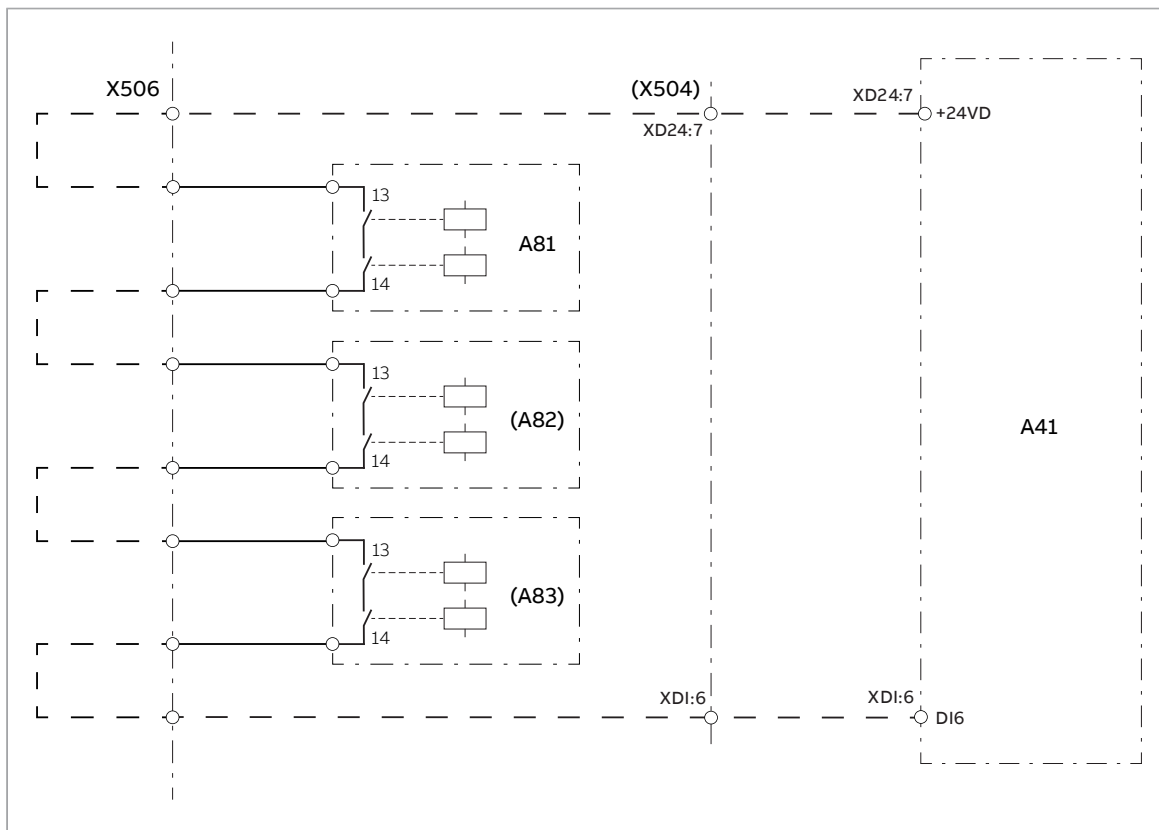

---	The dashed line in the figure shows a user-defined installation
A41	Drive/inverter control unit
A81	Extension relay, stator windings
A82	Extension relay, bearings
A83	Extension relay, stator windings
X504	Additional I/O terminal block (option +L504)

Commissioning

To commission the drive and the FSO module, refer to [Parameter settings \(page 51\)](#).

■ Commissioning the drive for a motor in a hazardous area

Commission the drive according to the requirements and limitations set by the application, the motor manufacturer's instructions, drive hardware and firmware manuals, local laws and regulations, and this manual.

The certificate of the Ex motor typically requires that you set a minimum limit for the output switching frequency of the drive. Make sure that the Ex motor is operated above the minimum output switching frequency specified by the motor manufacturer.

■ Configuring the GM International D5273S relay

You must always check all parameter values to make sure that they are suitable for your application. The pre-set values in a delivered GM International D5273S relay or factory default values are not valid for any safety application as such.

To configure the GM International D5273S relay:

1. Install the SWC5090 configuration software from <https://gminternational.com/> on your laptop or computer.
2. Plug the PPC5092 adapter into an USB port of your laptop or computer and connect it to the relay with the USB cable.
 - The PPC5092 adapter kit from GM International, containing both the adapter and the USB cable, is delivered with the drive. You can also order the PPC5092 adapter kit from ABB with ordering code 3AXD50001131753.
3. Open the SWC5090 configuration software, tab **Configuration**, and further its subtabs.
4. Adjust the settings according to the actual configuration. Make sure that Burnout is activated in all subtabs. If Burnout is not activated, the relay does not react to open circuits. This means, for example, that the relay does not react to a situation where the sensor wiring is not connected to the input terminal of the relay.

The images below show the pre-set values configured by ABB.

44 ATEX-certified motor thermal protection function with Pt100 relays (+L514+Q971)

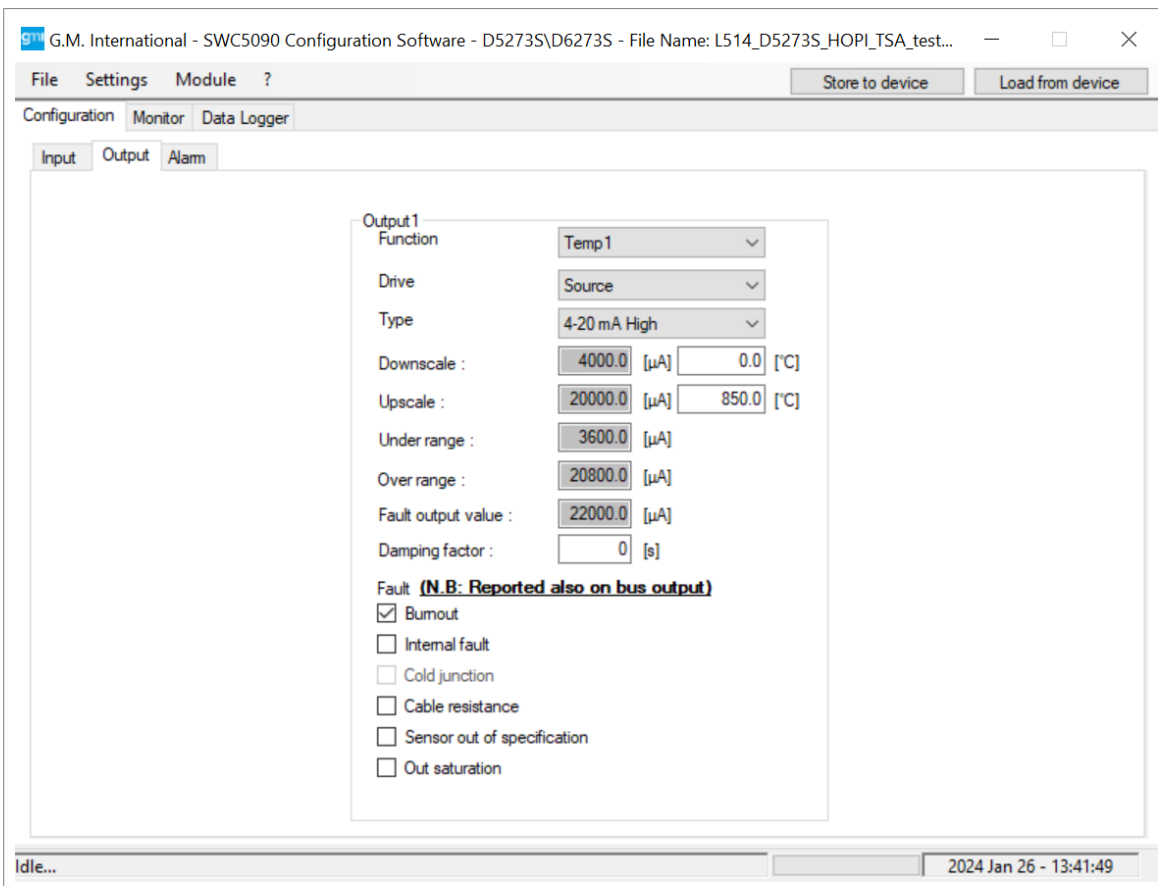
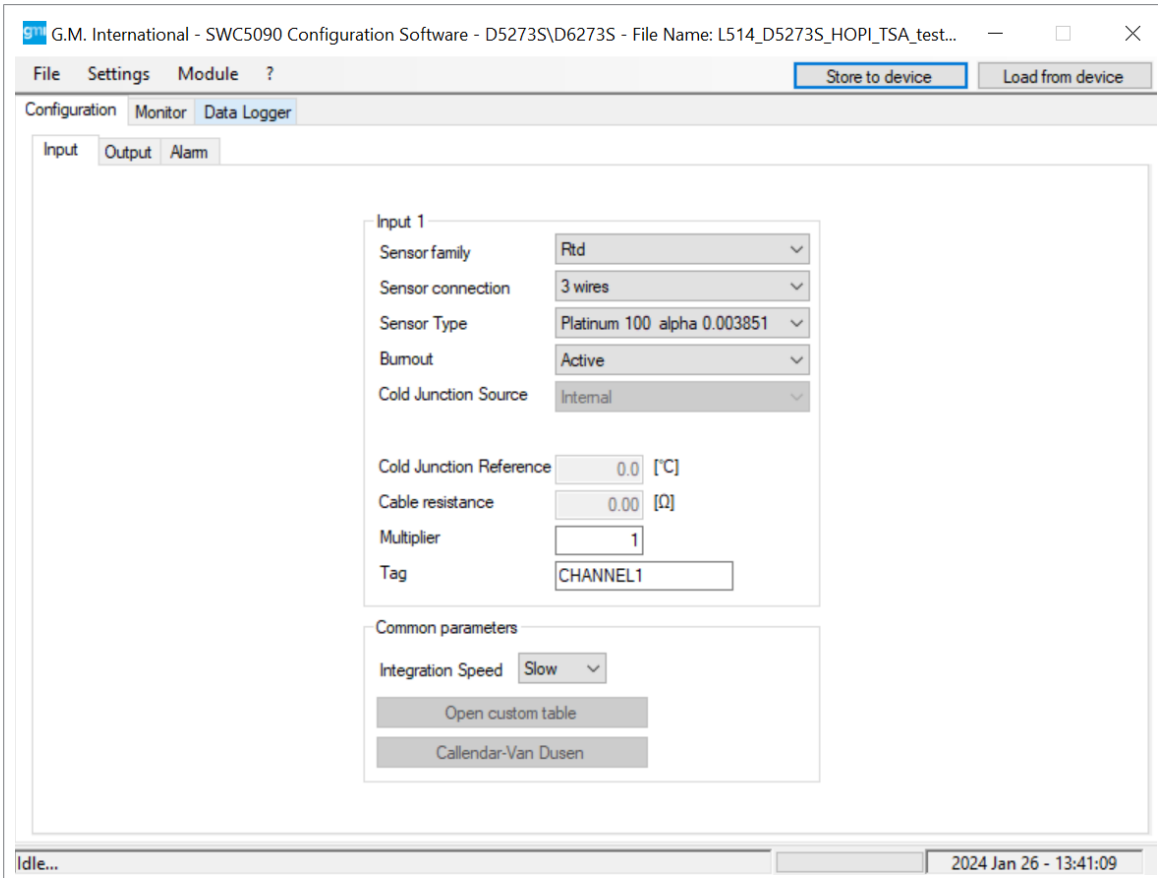

ATEX-certified motor thermal protection function with Pt100 relays (+L514+Q971) 45

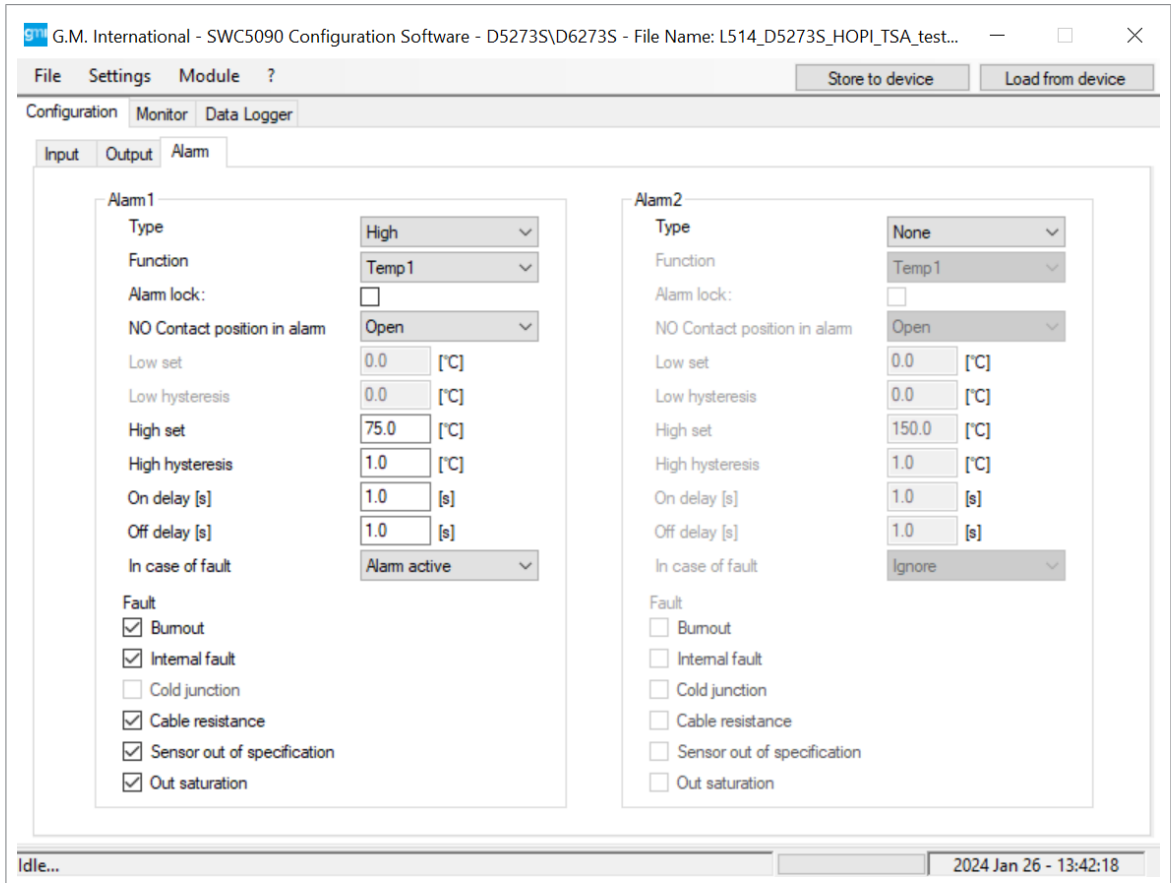

- **Configuring the PR electronics 9116B1 universal converter relay Contact ABB.**

Validation test

■ Validation of the safety functions

You must do a validation test to make sure that the safety function operates correctly and according to the safety requirements.

Competence

The person who does the validation test of the safety function must be a competent person with expertise and knowledge of the safety function and functional safety, as required by IEC 61508-1 clause 6 and Ex regulations. This person must document and sign the test procedures and report.

Validation procedure

If you use an FSO module in the safety system, you must validate the general settings of the FSO module and the safety encoder (if used) before you validate the safety function. Refer to the FSO module user's manual, chapter **Verification and validation**.

You must do the validation test using the checklist given in this manual and the validation test plan of the complete safety system:

- at the initial start-up of the safety function
- after changes related to the safety function (wiring, components, safety function -related parameter settings, etc.)
- after changes related to the power unit or its circuit boards
- after maintenance work related to the safety function
- at the proof test of the safety function.

The validation test must include at least the following steps:

- you must have a validation test plan
- you must test all commissioned functions for correct operation, from each operation location
- you must document all validation tests
- you must sign and store the validation test report for further reference.

Validation test reports

You must store the signed validation test reports in the logbook of the machine and in the explosion protection document under the scope of the ATEX User Directive 1999/92/EC or The Dangerous Substances and Explosive Atmospheres Regulations 2002 (UK). The report must include, as required by the referred standards:

- a description of the safety application (including a figure)
 - a description and revisions of safety components that are used in the safety application
 - a list of all safety functions that are used in the safety application
 - a list of all safety-related parameters and their values
-

- documentation of start-up activities, references to failure reports and resolution of failures
- the test results for each safety function, checksums, date of the tests, and confirmation by the test personnel.

You must store any new validation test reports done due to changes or maintenance in the logbook of the machine and in the explosion protection document under the scope of the ATEX User Directive 1999/92/EC or The Dangerous Substances and Explosive Atmospheres Regulations 2002 (UK).

■ Validation test procedure

Use the Drive Composer PC tool or a control panel to do the start-up and validation test. If you use an FSO module, you must use the Drive Composer pro PC tool.

Action	<input checked="" type="checkbox"/>
 WARNING! Obey the safety instructions of the drive. If you ignore them, injury or death, or damage to the equipment can occur.	<input type="checkbox"/>
Initial status	
<u>With an FSO-21 and FSE-31 module:</u> If you use a safety encoder in the safety application, validate the safety encoder interface as described in FSO-21 safety functions module user's manual (3AXD50000015614 [English]) , chapter Verification and validation .	<input type="checkbox"/>
Make sure that the drive is ready for use, that is, you have done the tasks of the drive start-up procedure. See the drive hardware manual.	<input type="checkbox"/>
Make sure that the drive STO function is configured and validated. See the hardware manual.	<input type="checkbox"/>
<u>With an FSO module:</u> Make sure that the FSO STO function is configured and validated. Internal monitoring of the FSO module can trigger the STO function even if you have not defined an external request signal. The STO function must be validated before other safety functions. Note: If you use a safety encoder, and parameter S_ENCGEN.11 is set to Est switch not active load, both STO function with speed estimate and STO function with encoder feedback must be tested - most importantly, the value of parameter STO.14 must be set according to the application requirements.	<input type="checkbox"/>
Checks and settings with no voltage connected	
Stop the drive and do the steps in section Electrical safety precautions (page 11) before you start the work.	<input type="checkbox"/>
Make sure that the classification of the motor thermal protection function corresponds to the Ex classification of the environment and the Ex motor.	<input type="checkbox"/>
The motor manufacturer selects the Pt100 sensors for the motor temperature measurement. Make sure that the temperature trip levels match those of the Pt100 relay and set the relay accordingly.	<input type="checkbox"/>
Make sure that the installation of Pt100 sensors complies with the requirements for the applicable type of protection. See section Wiring (page 40) .	<input type="checkbox"/>
Set the trip level of the Pt100 relay. For example, for temperature class T3 the values are: <ul style="list-style-type: none"> • 120...140 °C when only tripping is used • alarm 120...140 °C and trip 130...150 °C when both alarm and trip are used. Set the temperatures according to the temperature class of the motor. To change the settings of the relay, you must use a configuration tool. See the technical data for the ordering information.	<input type="checkbox"/>
Make sure that the other settings of the relay are correct.	<input type="checkbox"/>
Make sure that the wires are connected to the correct terminals and that the terminal connections are tightened to the correct torque.	<input type="checkbox"/>

48 ATEX-certified motor thermal protection function with Pt100 relays (+L514+Q971)

Action	<input checked="" type="checkbox"/>
Settings with voltage connected	
Close the cabinet doors and power up the drive. See the hardware manual.	<input type="checkbox"/>
Make sure that the parameter settings related to the safety function are correct. See chapter Parameter settings .	<input type="checkbox"/>
If necessary, configure the motor overtemperature indication message. See section Motor overtemperature indication (page 52) .	<input type="checkbox"/>
Make sure that the drive (or FSO module) is configured for a manual reset of the safety function.	<input type="checkbox"/>
Validation test procedure	
Do a broken wire detection test: disconnect the sensor circuit. Make sure that: <ul style="list-style-type: none">• the protection relay and extension relay trip• the motor coasts to a stop (STO), or is decelerated to zero speed (SS1)• the drive STO is activated• the correct indications are shown.	<input type="checkbox"/>
With the protection and extension relay(s) in tripped state, try to start the drive. The drive must not start before you reset the drive (and FSO) faults.	<input type="checkbox"/>
Create a backup file of the drive parameters with the Drive Composer PC tool or control panel.	<input type="checkbox"/>
<u>With an FSO module:</u> Save the FSO safety file (button Save safety file in the Drive Composer pro PC tool).	<input type="checkbox"/>
Fill in and sign the validation test report. Store the report in the logbook of the machine.	<input type="checkbox"/>

Fault tracing

For the warning and fault messages generated by the drive, see the drive firmware manual.

For the fault indication LEDs of the relays, see section [Pt100 relays \(page 37\)](#).

For the status LEDs of the FSO module, see the FSO module user's manual.

■ Reporting problems and failures related to safety functions

Contact ABB.

Technical data

Refer to [Technical data \(page 65\)](#).

■ Safety data and block diagrams

The safety block diagrams show the components that are included in the safety data calculations.

Without an FSO module

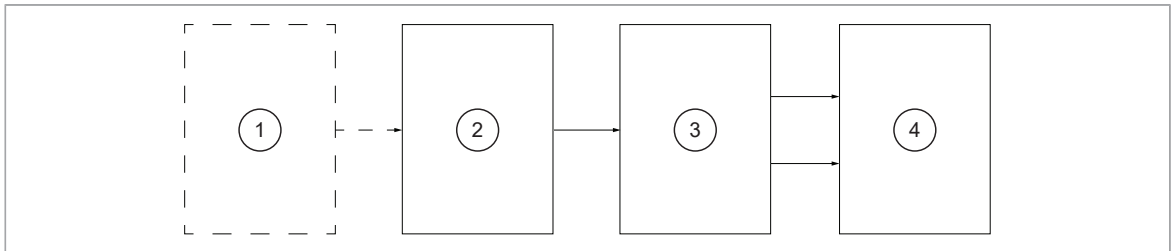

1	Customer motor Pt100 sensor(s)
2	Pt100 relay(s) <ul style="list-style-type: none"> • K71.1...3 • (K72.1...2) • (K73.1...3)
3	Extension relay(s) <ul style="list-style-type: none"> • A81 • (A82) • (A83)
4	Drive STO

SIL	HFT	T ₁	PFD _{avg} (3, 5, or 8 relays)
1	0	2 years	1.10E-03
3AXD10000331763 G			

Mission time (T_M) = 20 years.

With an FSO module

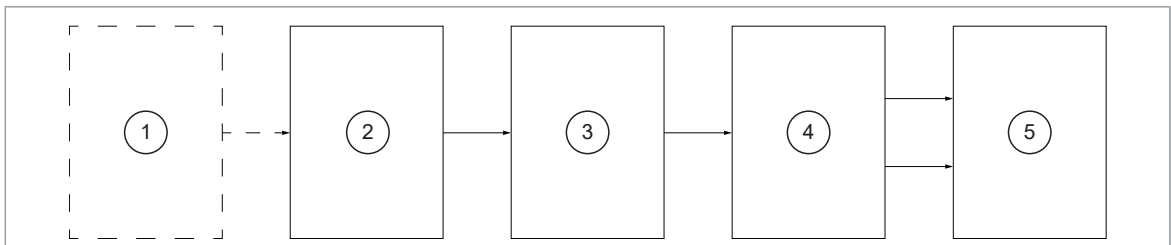

1	Customer motor Pt100 sensor(s)
2	Pt100 relay(s) <ul style="list-style-type: none"> • K71.1...3 • (K72.1...2) • (K73.1...3)
3	Extension relay(s) <ul style="list-style-type: none"> • A81 • (A82) • (A83)
4	FSO module FSE module (optional) ¹⁾
5	Drive STO

¹⁾ The FSE module is included in the calculations only if

- a safety encoder is used in the application, and
- the FSO-21 module is configured to activate the SS1 function (stop category 1) in overtemperature situations, and
- the ramp monitoring method is used in the SS1 function.

50 ATEX-certified motor thermal protection function with Pt100 relays (+L514+Q971)

SIL	HFT	T₁	PFD_{avg} (3, 5, or 8 relays)
1	0	2 years	1.21E-3
			3AXD10000331763 G

Mission time (T_M) = 20 years.

5

Parameter settings

Contents of this chapter

This chapter lists the parameters that you have to set for the ATEX/UKEX-certified motor thermal protection functions in this manual.

**WARNING!**

If there is missing or inaccurate information, do not operate the motor before you have made sure that the parameter settings are correct.

Drive / inverter

■ Switching frequency limitation

The certificate of the Ex motor typically requires that you set a minimum limit for the switching frequency of the drive.

For ABB Ex motors, use parameter 95.15 to set the required minimum switching frequency. For more information, refer to the drive firmware manual.

For Ex motors supplied by other motor manufacturers, contact the motor manufacturer for the correct value and your local ABB representative for instructions on how to make the parameter setting in the drive.

■ Reset method and status indications

To configure a manual reset for the temperature protection function in the drive, you can set either the STO indication (parameter 31.22) or the motor temperature indication so that it generates a fault.

31.22 STO indication run/stop

Set this parameter to value Fault/Fault or Fault/Warning.

- **Fault/Fault:** This generates a fault in the drive/inverter unit when STO is activated.
- **Fault/Warning:** This generates a fault in the drive/inverter unit when the drive is running and warning when the drive is stopped.

When the drive/inverter unit generates a fault indication because of STO activation, you must reset the drive/inverter unit before you can restart the drive.

Note: You can also configure the FSO module so that it sends a fault to the drive each time it activates the drive STO function. See parameter [FSOGEN.61](#).

The default values set for the options at the factory:

- option +L513+Q971 (PTC relays, with or without an FSO module): Warning/Warning
- option +L514+Q971 (Pt100 relays, with or without an FSO module): Fault/Fault.

Motor overtemperature indication

There are two ways to configure the motor overtemperature indication.

Example 1

The ACS880 primary control program has two separate temperature monitoring functions. In this example, one of these functions (External event 1) is configured to monitor digital input DI6. When the input is de-energized (0), the function triggers the user-selected indication and shows the user-defined message. To configure the motor overtemperature indication in the drive:

1. Select the digital input which shows the status of the external event: set parameter 31.01 External event 1 source to value DI6. You can also use another digital input.
2. Select the type of the External event 1: set parameter 31.02 External event 1 type to Fault, Warning or Warning/Fault. If you set this parameter to Fault, the drive trips due to overtemperature and you must reset the drive with a manual reset command before you can restart the drive. If you use an FSO module and parameter 31.02 is set to Fault, you must configure the safety function in the FSO module so that it activates the STO function (stop category 0). The use of the SS1 stopping function is not possible with this motor overtemperature indication method.
3. If necessary, edit the indication message. You can use the control panel or Drive Composer PC tool to edit messages.

Example 2

In this example, the motor temperature is read from digital input DI6.

1. Select PTC DI6 as the source of the temperature with parameter 35.11 Temperature 1 source. Use the same setting also with Pt100 sensors.
2. By default, the overtemperature indication is configured to give a warning. To generate a fault instead, set parameter 35.12 Temperature 1 fault limit to 4000 ohm.
3. If necessary, edit the indication message. You can use the control panel or Drive Composer PC tool to edit messages.

For more information, see [ACS880 primary control program firmware manual \(3AUA0000085967 \[English\]\)](#).

31.11 Fault reset selection

Select the correct source of an external fault reset signal with parameter 31.11 Fault reset selection.

■ Other recommended settings

ABB recommends that you also set these parameters to improve the safety of the application:

- minimum and maximum speeds (parameter group 30)
- maximum current, power and torque (group 30)
- acceleration and deceleration times
- stall protection (parameters 31.24...31.28)
- motor load curve (parameters 35.50...35.55)
- motor cable protection (parameters 35.60...35.62)

For more information, see the drive firmware manual.

FSO module

If you use an FSO module (option +Q972 or +Q973) in the safety system configuration, set the parameters according to the system requirements. Example values are shown in this section.

The person who configures the safety functions in the FSO module must be a competent person as required by IEC 61508-1 clause 6. In this context, the person must have expertise and knowledge of functional safety, the safety functions and the configuration of the FSO module. ABB has training courses on the FSO module.

You must use the Drive Composer pro PC tool to set the FSO module parameters. You also need a password to be able to download the configuration to the FSO module from Drive Composer pro. For the default password of the FSO module, see the applicable FSO module user's manual. For more information on the Drive Composer pro PC tool, see [Drive Composer start-up and maintenance PC tool user's manual \(3AUA0000094606 \[English\]\)](#).

Note: When the drive is running/ modulating, you cannot change the password, adjust parameter values, or upload or download the FSO configuration file.

Follow the configuration steps described in the applicable FSO module user's manual, chapter **Configuration**.

There are parameters that you must always set when you use the FSO module, and parameters that are related only to some safety functions. These tables list the parameters that are related to options +L513+Q971+Q973/Q972 and +L514+Q971+Q973/Q972. The example values are applicable only to these options.

If you use the FSO-21 module (+Q972) with a FSE-31 pulse encoder interface module (+L521) and safety encoder, set the parameters listed in section [FSE module and safety encoder parameters \(page 61\)](#).

You can configure the FSO module so that it opens the drive or inverter STO circuit immediately (STO function in the FSO module, stop category 0) or after a deceleration ramp (SS1 function in the FSO module, stop category 1). For the options described in this manual, ABB configures the FSO module so that it activates the STO function (stop category 0). Select the stop category according to the system risk assessment. Do not configure the STO function and the SS1 function to the same input at the same time.

Note: Setting parameters related to STO, SSE and SS1 can also have an effect on other safety functions. You must take all safety functions into consideration when you configure the FSO module. See the applicable FSO module user's manual and safety option user's manual.

Note: The FSO module has a factory reset button. The factory reset button clears the configuration and sets the parameters to the factory default values. These values are not the same as the pre-set values in an FSO module that was ordered as an option (with a plus code). You cannot restart the drive with the factory default values. If you do a factory reset of the FSO module, you must reconfigure the FSO module and set all applicable parameters. Because of this, it is recommended to save the FSO safety file with the button **Save safety file** in the Drive Composer pro PC tool. For more information, see the FSO module user's manual and the Drive Composer PC tool user's manual.

■ General parameters

These parameters are common to all safety functions in the FSO module.

Index	Name	Example value	Description
FSOGEN.11	Stop completed output	None	Sets the digital output that indicates the completion of any stop function. Active when the FSO module has completed the STO, SSE or SS1 function. <u>ACS880-07/07LC/17/17LC/37/37LC drives with option +Q978 or +Q979:</u> ABB configures the emergency stop indication lamp to this digital output at the factory. Make sure that this value agrees with the circuit diagrams of the delivery.
FSOGEN.21	Motor nominal speed	100.0 rpm	Sets the synchronous motor speed.
FSOGEN.22	Motor nominal frequency	50.00 Hz	Sets the nominal motor frequency. Adjust the default value to meet the ratings of the motor in use.
FSOGEN.41	Power-up acknowledgement	Automatic	Sets the power-up acknowledgement method of the FSO module. Automatic: You do not need to push a reset button after switching on the FSO module. The FSO module generates the acknowledgement signal automatically after the power-up. Manual: The FSO module reads the external acknowledgement signal through the digital input defined by parameter FSOGEN.42 . Make sure that the value is Automatic.

Index	Name	Example value	Description
FSOGEN.42	Acknowledgement button input	None	<p>Sets the digital input for the acknowledgement signal when parameter STO.02 has value Manual.</p> <p>None: In the safety functions described in this manual, parameter STO.02 has value Automatic and this parameter has value None (no acknowledgement signal connected).</p> <p>In the safety functions described in this manual, you can use this parameter to implement manual reset in the FSO module. Set the digital input which the reset circuit is connected to with this parameter.</p> <p><u>ACS880-07/07LC/17/17LC/37/37LC drives with option +Q978 or +Q979:</u> The value of this parameter is DI X113:2. A reset circuit is connected to the FSO module and the user must reset the safety function with the emergency stop reset button also when motor overtemperature is reached. Do not change this setting.</p>
FSOGEN.51	Zero speed without encoder	90.0 rpm	<p>Sets the general zero speed limit for safety functions when a safety encoder is not used.</p> <p><u>STO function:</u> The value has no effect.</p> <p><u>SS1 function:</u> The FSO module activates the drive STO function when the drive decelerates the motor speed below this value. Adjust the default value according to application requirements.</p> <p><u>ACS880-07/07LC/17/17LC/37/37LC drives with option +Q978:</u> Also the main contactor/breaker is opened.</p>
FSOGEN.52	Zero speed with encoder	0.0 rpm	<p>Sets the general zero speed limit for safety functions when a safety encoder is used.</p> <p><u>STO function:</u> The drive STO function is active (cannot be reset) until the motor speed is less than or equal to this value.</p> <p><u>SS1 function:</u> The FSO module activates the drive STO function when the drive decelerates the motor speed below this value. Adjust the default value according to application requirements.</p> <p><u>ACS880-07/07LC/17/17LC/37/37LC drives with option +Q978:</u> Also the main contactor/breaker is opened.</p> <p>Note: This parameter is used only with FSO-21 and when a safety encoder is used in the application.</p>
FSOGEN.61	STO indication ext request	Warning	<p>Sets the type of the event that the FSO module generates and sends to the drive after external requests that end to a successful activation of the drive STO function (STO, SSE or SS1).</p> <p>None, Warning, Event: You do not have to reset the drive/inverter unit.</p> <p>Fault: You have to reset the drive/inverter unit.</p> <p>In the safety functions described in this manual, you can use this indication as the motor overtemperature indication message and to implement a manual reset. Adjust the default value when necessary.</p>

Index	Name	Example value	Description
FSOGEN.62	STO indication safety limit	Fault	<p>Sets the type of the event that the FSO module generates and sends to the drive for limit hits during ramp and time monitoring of safety ramps SAR0 and SAR1.</p> <p><u>STO function:</u> The value has no effect.</p> <p><u>SS1 function:</u> When the motor speed does not follow the stop ramp or the time limit is exceeded, the FSO module activates the STO function and generates this user-defined indication. Adjust the default setting if necessary. If you select <i>Fault</i>, you must reset the drive before you can restart it.</p>

■ Parameters for the STO function

These parameters are related to the STO function of the FSO module. With stop category 0, the FSO module activates the STO function in overtemperature situations. Also, the FSO module can activate the STO function in fault situations.

Index	Name	Example value	Description
STO.02	STO acknowledgement	Automatic	<p>Sets the acknowledgement method used in the STO, SSE and SS1 functions.</p> <p><u>Automatic:</u> The FSO module resets the STO function automatically after the STO request is removed.</p> <p><u>Manual:</u> The FSO module reads the external acknowledgement signal through the digital input defined by parameter FSOGEN.42. In the safety functions described in this manual, you can use this setting to implement a manual reset for the motor temperature protection function in the FSO module.</p> <p><u>ACS880-07/07LC/17/17LC/37/37LC drives with option +Q978 or +Q979:</u> The FSO module is configured so that after the safety function activation, the user must reset the FSO manually with the emergency stop reset button (this parameter is set to Manual). In this case, the user must reset the FSO module with the emergency stop reset button also when motor overtemperature is reached. Do not change this setting.</p>
STO.11	STO input A	None	<p>Sets the digital input that is connected to the primary input of the STO function.</p> <p>In the safety functions described in this manual, this parameter has value None.</p> <p><u>ACS880-07/07LC/17/17LC/37/37LC drives with option +Q978 or +Q979:</u> ABB connects the emergency stop button to this digital input at the factory. Make sure that the setting agrees with the circuit diagrams of the delivery.</p> <p><u>ACS880 multidrives with option +Q979:</u> ABB connects the emergency stop safety relay to this digital input at the factory. Make sure that the setting agrees with the circuit diagrams of the delivery.</p>

Index	Name	Example value	Description
STO.12	STO input B	<u>STO</u> : DI X113:4 <u>SS1</u> : None	<p>Sets the digital input that is connected to the secondary input of the STO function.</p> <p>For the safety functions described in this manual, ABB configures the contacts of the PTC/Pt100 relay to this digital input at the factory. Make sure that the setting agrees with the circuit diagrams of the delivery.</p> <p>If you set this parameter to DI X113:4, set parameter SS1.12 to None.</p>
STO.13	Restart delay after STO	2000 ms	<p>Sets the time after which the drive can restart when the FSO module has activated the STO function and opened the drive STO circuit. With this parameter, you can let the drive restart before the motor has stopped (fly-start). This parameter is relevant only if the STO function is requested from STO input A (STO.11) or STO input B (STO.12).</p> <p><u>STO function</u>: Adjust the value when necessary. If you do not use the fly-start feature, set this parameter to the same value as parameter STO.14.</p> <p><u>SS1 function</u>: This value has no effect.</p>
STO.14	Time to zero speed with STO and mod-off	2000 ms	<p>Sets the time that is needed to coast the motor to a standstill from maximum process speed. If this time is not known, it can be measured with the Drive Composer pro PC tool when an encoder is used for motor control (otherwise you have to make sure that the motor shaft has stopped rotating by other means, eg, visually).</p> <p>Acknowledgement is allowed after coast stop in the STO, SSE and SS1 functions (when SBC is not used). If the drive STO is activated or modulation stopped while a monitoring safety function is indicating "unsafe", after this time acknowledgement is allowed. For example, if the drive modulation is lost during SLS deceleration ramp, SLS OK will be indicated after this time has elapsed.</p> <p><u>STO function</u>: This parameter sets the time after which the STO function is completed and the STO completed indication goes on. Parameter STO.13 defines the time after which the acknowledgement is allowed. Adjust the value according to application requirements.</p> <p><u>SS1 function</u>: This parameter is used only when the motor speed does not follow the ramp settings or the time monitoring limit is exceeded and the FSO module activates the STO function. Adjust the value according to application requirements.</p> <p><u>When an encoder is used</u>: This parameter is relevant only if there is an encoder failure and the FSO module activates the STO function.</p>

58 Parameter settings

Index	Name	Example value	Description
SBC usage			
SBC.11	STO SBC usage	None	<p>Sets how the mechanical brake is used together with the STO function.</p> <p>In the safety functions described in this manual, this feature is not used and this parameter has value None.</p> <p><u>ACS880-07/07LC/17/17LC/37/37LC drives with option +Q978</u>: The SBC function is used in the emergency stop implementation to control the auxiliary safety relay(s) which is connected to the main contactor/breaker. Make sure that the value is Delayed brake.</p>
I/O settings			
SAFEIO.36	DI X113:4 diag pulse on/off	Off	<p>Sets the diagnostic pulse of digital input X113:4 on or off.</p> <p>On: The input monitors that it receives test pulses.</p> <p>Off: The input does not monitor for test pulses.</p> <p>In the safety functions described in this manual, test pulses are not used. Make sure that the value is Off.</p>

■ Parameters for the SSE function

These parameters are related to the Safe stop emergency (SSE) function of the FSO module. The safety functions described in this manual do not use this function, but the FSO module can activate the SSE function in internal fault situations.

Index	Name	Example value	Description
SSE.13	SSE function	Immediate STO	<p>Sets the type of the SSE function.</p> <p>Immediate STO: The FSO module activates the drive STO function immediately after the SSE request (stop category 0).</p> <p>Emergency ramp: The FSO module first ramps down the motor speed and when the speed is below the zero speed limit (parameter FSOGEN.51 or FSOGEN.52) it activates the STO function (stop category 1). SAR0 parameters define the deceleration ramp (for more information, see the FSO module user's manual).</p> <p>For the safety functions described in this manual, ABB has set this parameter to value Immediate STO at the factory. Adjust the default value when necessary.</p>
SBC usage			
SBC.15	SSE/SS1 SBC speed	0.0 rpm	<p>Sets the absolute speed below which the FSO module activates the brake (SBC) while ramping.</p> <p>0.0 rpm: The feature is not in use.</p> <p>In the safety functions described in this manual, this feature is not used. Make sure that the value is 0.0 rpm.</p>

■ Parameters for the SS1 function

Set these parameters only if you want that the FSO module activates the SS1 function in overtemperature situations (stop category 1).

Index	Name	Example value	Description
SS1.01	SS1 activity and version	Version 1	Activates or deactivates the SS1 function and shows the version of the SS1 function. Version 1: Activates version 1 of the SS1 function. For more information, see the FSO module user's manual.
SS1.11	SS1 input A	None	Sets the digital input that is connected to the primary input of the SS1 function.
SS1.12	SS1 input B	STO: None SS1: DI X113:4	Sets the digital input that is connected to the secondary input of the SS1 function. If you set this parameter to DI X113:4, set parameter STO.12 to None.
SS1.13	SS1 type	SS1-r	Sets the method used for the SS1 monitoring. Adjust the default value when necessary. <u>Time monitoring (SS1-t)</u> : The FSO module monitors that a user-defined deceleration time limit is not exceeded. (See parameter SS1.14 .) <u>Ramp monitoring (SS1-r)</u> : The FSO module monitors that the motor decelerates along a user-defined stop ramp. (See SAR1 ramp parameters 200.112 , SARx.21 , SARx.22 and SARx.02 .)
SS1.14	SS1-t delay for STO	20000 ms	Sets the monitoring delay after which the FSO module activates the drive STO and SBC at the latest, if the motor speed has not gone below the zero speed limit (parameter FSOGEN.51 or FSO-GEN.52) yet. <u>Time monitoring</u> : This value sets the security delay that the FSO module monitors. Adjust the default value when necessary. <u>Ramp monitoring</u> : This value has no effect in the operation.
SAR1 ramp settings			
200.112	SAR1 ramp time to zero	2000 ms	Sets the target time for the stop ramp SAR1 that is used in the SS1 and function. Adjust the default value when necessary. The target time is the time in which the drive decelerates the motor from the speed defined by parameter 200.202 to zero. Note: With value 0 ms, the drive uses the emergency stop ramp set by drive parameter 23.23 . See SS1 ramp parameters in the drive/inverter unit (page 60) . Also in this case, the FSO module only monitors the actual ramp (ramp monitoring or time monitoring).
200.202	SAR speed scaling	1500 rpm	Sets a speed value that the FSO module uses as a reference point in ramp parameter calculations. See SAR1 ramp parameters 200.112 , SARx.21 , SARx.22 and SARx.02 . Adjust the default value when necessary.

60 Parameter settings

Index	Name	Example value	Description
SARx.02	SAR initial allowed range	100 ms	<p>Sets the initial allowed range for the SAR0/SAR1 ramp. This parameter moves the location of the maximum monitoring ramp forward on the time axis, when monitoring is started. The slope of the ramp stays the same as defined with parameters 200.202 and SARx.22. For more information, see the FSO module user's manual.</p> <p><u>Time monitoring:</u> This value has no effect in the operation.</p> <p><u>Ramp monitoring:</u> Adjust the default value when necessary.</p>
SARx.21	SAR1 min ramp time to zero	1000 ms	<p>Sets the minimum ramp time for the SAR1 ramp monitoring.</p> <p><u>Time monitoring:</u> This value has no effect in the operation.</p> <p><u>Ramp monitoring:</u> Sets the minimum stop ramp time for the emergency stop. Adjust the default value when necessary.</p> <p>Note: With value 0 ms, the minimum ramp is not monitored.</p>
SARx.22	SAR1 max ramp time to zero	3000 ms	<p>Sets the maximum ramp time for the SAR1 ramp monitoring.</p> <p><u>Time monitoring:</u> This value has no effect in the operation.</p> <p><u>Ramp monitoring:</u> Sets the maximum stop ramp time for the emergency stop. Adjust the default value when necessary.</p>
SBC usage			
SBC.15	SSE/SS1 SBC speed	0.0 rpm	<p>Sets the absolute speed below which the FSO module activates the brake (SBC) while ramping.</p> <p>0.0 rpm: The feature is not in use.</p> <p>In the safety functions described in this manual, this feature is not used. Make sure that the value is 0.0 rpm.</p>

In addition to the parameters related to the SS1 function, set these parameters.

Index	Name	Pre-set value (STO function)	Value with the SS1 function
STO.12	STO input B	DI X113:4	None
FSOGEN.51	Zero speed without encoder	90.0 rpm	If you do not use a safety encoder, adjust the default value to meet the motor in use.
FSOGEN.52	Zero speed with encoder	0.0 rpm	If you use a safety encoder, adjust the default value to meet the motor in use.
FSOGEN.62	STO indication safety limit	Fault	Adjust the default value when necessary.

SS1 ramp parameters in the drive/inverter unit

If you use the SS1 function (stop category 1) and set FSO parameter [200.112](#) to 0 ms, also set the drive parameters as follows:

- set 21.04 Emergency stop mode to Eme ramp stop (Off3)
- set 23.23 Emergency stop time according to application requirements.

If FSO parameter [200.112](#) is set to 0 ms, drive parameters define the stop ramp that is used in the SS1 function. Also, the FSO module monitors the actual stop ramp (ramp monitoring or time monitoring). For more information, see the drive firmware manual and FSO module user's manual.

■ FSE module and safety encoder parameters

Set these parameters only when you use a safety pulse encoder and the FSE-31 pulse encoder interface module with the FSO-21 module.

Index	Name	Example value	Description
200.231	FSE 3X act and par version	Version 1	Activates the FSE-31 encoder interface and shows the version of the encoder parameter groups (91 and 92).
200.232	Number of encoders	Single encoder CH1	Shows the number of safety encoders connected to the FSE module.
S_ENCGEN.01	Safe pulse encoder version	Version 1	Activates the safety encoder and shows the version parameter group S_ENCGEN.
S_ENCGEN.11	FSE diagnostic failure reaction	STO	Sets the action taken when there is a problem with the FSE module or the safety encoder. STO: The FSO module goes into the Fail-safe mode and activates the drive STO function.
S_ENCGEN.14	Enc speed cross comp tolerance	1.0 rpm	Sets the encoder speed cross comparison tolerance. This defines how much the axle speed of the motor can change within 1 ms. Adjust the default value to meet the motor in use. This parameter is used for the encoder diagnostic. It defines the maximum difference between the speed information from channel A and B of the encoder. If the difference of these two values is more than defined by this parameter, FSO will safely stop the system (STO). The suitable value depends on the configuration (motor and load). Typically this value is between 2 ... 10 rpm. A value that is too small will cause an encoder fault (A7D8). A value that is too large will prevent the encoder diagnostic related to this parameter.
S_ENCGEN.41	Gear numerator encoder 1	1	Sets the rotation direction for the safety encoder. With this parameter, you can change the rotation direction of the motor. Adjust the default value if necessary.
91.11	Module 1 type	FSE-31	Sets the type of the safety encoder interface module 1.
91.12	Module 1 location	2	Sets the slot in which the safety encoder interface module 1 is located.
92.01	Encoder 1 type	HTL1	Activates or deactivates the communication with the safety encoder interface module 1 and sets the type for the safety encoder.
92.02	Encoder 1 source	Module 1	Sets the safety encoder interface module that the safety encoder 1 is connected to.
92.10	Pulses/revolution	2048	Sets the number of HTL pulses per revolution for safety encoder 1. Adjust the default value to meet the safety encoder in use. Make sure that the value is according to the encoder nameplate.

Index	Name	Example value	Description
92.17	Accepted pulse freq of encoder 1	300 kHz	<p>Sets the maximum pulse frequency range of encoder 1. Adjust the default value to meet the motor and safety encoder in use. You can use this formula to define the value: $(r_max [rpm] / 60 \times ppr_snc [p/rev]) / 1000 + 10\%$, where</p> <ul style="list-style-type: none"> r_max: the maximum motor speed (rpm) used in the application (or the motor nominal speed) ppr_enc: pulses/revolution of the safety encoder (parameter 92.10).

■ Notes

ACS880-07/07LC/17/17LC/37/37LC drives with option +Q978: In motor overtemperature situations, the FSO module also opens the main contactor/breaker.

ACS880-07/07LC/17/17LC/37/37LC drives with option +Q978 or +Q979: The FSO module is configured so that after the safety function activation, the user must reset the FSO module manually with the emergency stop reset button. The user must also reset the FSO module with the emergency stop reset button after motor overtemperature situations. The indication lamp on the reset button is on. Do not change this setting.

Mechanical brake control

If you use a mechanical brake with the motor thermal protection circuit, pay special attention to the control of the mechanical brake.

If the motor deceleration by the mechanical brake causes extra heat generation in the Ex zone, make sure that the use of the brake does not increase the temperature too much. In this case, make sure that the mechanical brake is activated only at zero speed (see parameters [SBC.11](#), [SBC.15](#) and [FSOGEN.51](#) or [FSOGEN.52](#)).

In some cases you cannot use the brake for the motor deceleration when the motor thermal protection circuit has tripped and the motor temperature is too high.

For more information, see the drive firmware manual (or the FSO module user's manual if you use the Safe brake control (SBC) function of the FSO module).



Maintenance

Contents of this chapter

This chapter contains information for the maintenance and decommissioning of the safety function.

Safety circuit maintenance

After the safety function is validated, it must be maintained by periodic proof testing.

If you change the wiring or a component after the start-up, replace a power unit or its circuit boards, replace the FSO or FSE-31 module, modify FSO module parameters, replace safety relays, or restore parameters to their factory default values:

- Use only ABB-approved spare parts.
- Register the change to the change log for the safety circuit.
- If parameters were restored to the factory default values: Set the parameters related to the safety function.
- Do the validation test of the safety function.
- Document the tests and store the report into the logbook of the machine.

Proof test interval

Proof tests are used to detect failures in the safety function. To do a proof test, use the validation test procedure given in this manual.

Periodic proof testing of the safety function is necessary to maintain the required SIL level. The maximum proof test interval is 2 years.

Competence

The person who does the maintenance and proof test activities of the safety function must be a competent person with expertise and knowledge of the safety function and functional safety, as required by IEC 61508-1 clause 6 and Ex regulations.

Intentional misuse

The safety circuit is not designed to protect a machine against intentional misuse.

Functional safety components

The mission time of functional safety components is 20 years which equals the time during which failure rates of electronic components remain constant. This applies to the components of the standard Safe torque off circuit as well as any modules, relays and, typically, any other components that are part of functional safety circuits.

The expiry of mission time terminates the certification and SIL/PL classification of the safety function. The following options exist:

- Renewal of the whole drive and all optional functional safety module(s) and components.
- Renewal of the components in the safety function circuit. In practice, this is economical only with larger drives that have replaceable circuit boards and other components such as relays.

Note that some of the components may already have been renewed earlier, restarting their mission time. The remaining mission time of the whole circuit is however determined by its oldest component.

Contact your local ABB service representative for more information.

Decommissioning

When you decommission a safety function, make sure that the safety of the machine is maintained by other means until the decommissioning is completed.

7

Technical data

Contents of this chapter

This chapter contains the technical specifications of the protection functions. It also gives general rules, notes and definitions related to safety functions and lists related standards. The ATEX/UKEX compliance markings and certificates are also included.

The ATEX-certified motor thermal protection functions

Response time: < 200 ms

PTC thermistor relays

■ ABB CM-MSS.41

Ordering information		
Part number	CM-MSS.41P (Push-in terminals)	1SVR740712R1200
	CM-MSS.41S (Screw terminals)	1SVR730712R1200
Power supply A1...A2		
Rated control supply voltage U_s		24 ... 240 V AC/DC
Rated control supply voltage U_s tolerance		-15 ... +10%
Rated frequency		15 ... 400 Hz
Typical current / power consumption	24 V AC/DC	33 mA / 0.55 VA
	220 ... 240 V AC	11 mA / 1.6 VA
Electrical insulation between supply circuit and measuring circuit		yes
Power failure buffering time		20 ms

66 Technical data

Measuring circuit / Sensor circuit T1...T2		
Sensor type		PTC type A (DIN/EN 44081, DIN/EN 44082)
Number of sensor circuits		1
Max. total resistance of sensors connected in series, cold state		< 750 ohm
Overtemperature monitoring	Switch-off resistance (relays de-energize)	2.83 kohm \pm 1%
	Switch-on resistance (relays energize)	1.1 kohm \pm 1%
Short-circuit detection	Switch-off resistance (relays de-energize)	< 12 ohm
	Switch-on resistance (relays energize)	> 19 ohm
Interrupted wire detection	Switch-off resistance (relays de-energize)	dynamic
	Switch-on resistance (relays energize)	not available
Non-volatile fault storage		configurable
Test function		yes
Maximum voltage in sensor circuit	1.33 kohm	2.5 V
	4 kohm	3.7 V
	∞ kohm	5.5 V
Maximum current in sensor circuit		3.7 mA
Maximum sensor cable length		2 \times 100 m at 0.75 mm ² 2 \times 400 m at 2.5 mm ²
Accuracy within the rated control supply voltage tolerance		0.50%
Accuracy within the temperature range		0.01%/K
Repeat accuracy (constant parameters)		on request
Reaction time of the safety function		< 100 ms
Hardware fault tolerance (HFT)		0
Control circuit S1...T2		
Control function	Manual reset	yes
	Auto reset	adjustable
	Remote reset	adjustable
Maximum no-load voltage (S1-T2 open)		5.5 V
Max. current (S1-T2 jumpered)		0.6 mA
Maximum cable length		2 \times 100 m at 0.75 mm ² 2 \times 400 m at 2.5 mm ²
Indication of operational states		
Control supply voltage		"U" LED (green)
Relay status		"R" LED (yellow)
Fault message		"F" LED (red)
Operating controls		
Test / Reset		front-face button

Configuration of	DIP switch 1	non-volatile fault storage
	DIP switch 2	short-circuit detection
	DIP switch 3	disabled
	DIP switch 4	Remote Test/Reset
Output circuit		
Kind of output	11-12/14	Relay, 1st c/o (SPDT) contact
	21-22/24	Relay, 2nd c/o (SPDT) contact
Operating principle		closed-circuit principle
Contact material		AgNi alloy, Cd free
Minimum switching voltage / Minimum switching current		24 V / 10 mA
Maximum switching voltage / Maximum switching current		See the relay data sheet.
Rated operational voltage U_e and rated operational current I_e	AC-12 (resistive) at 230 V	4 A
	AC-15 (inductive) at 230 V	3 A
	DC-12 (resistive) at 24 V	4 A
	DC-13 (inductive) at 24 V	2 A
AC Rating (UL 508)	Utilization category (Control Circuit Rating Code)	B 300
	Maximum rated operational voltage	300 V AC
	Maximum continuous thermal current at B 300	5 A
	Maximum making/breaking apparent power at B 300	3600/360 VA
	General purpose rating	250 V AC - 4 A
Mechanical lifetime		30×10^6 switching cycles
Electrical lifetime at AC-12, 230 V AC, 4 A		0.1×10^6 switching cycles
Maximum fuse rating to achieve short-circuit protection	N/C contact	10 A fast-acting
	N/O contact	10 A fast-acting
General data		
Duty cycle		100%
Dimensions (Height × Width × Depth)		85.6 mm × 22.5 mm × 103.7 mm (3.37 in × 0.89 in × 4.08 in)
Weight, net	Screw connection technology	0.141 kg (0.31 lbs)
	Easy Connect Technology (push-in)	0.130 kg (0.29 lbs)
Mounting		DIN rail (IEC/EN 60715), snap-on mounting without any tool
Minimum distance to other units	Vertical	10 mm (0.39 in) if switching current > 2 A
	Horizontal	10 mm (0.39 in) if switching current > 2 A
Material of housing		UL 94 V-0
Degree of protection	Housing	IP50
	Terminals	IP20

68 Technical data

Electrical connection		
Connecting capacity	Fine-strand with(out) wire end ferrule	Screw connection: <ul style="list-style-type: none"> • 1 × 0.5 ... 2.5 mm² (1 × 18 ... 14 AWG) • 2 × 0.5 ... 1.5 mm² (2 × 18 ... 16 AWG) Easy Connect Technology (push-in): <ul style="list-style-type: none"> • 2 × 0.5 ... 1.5 mm² (2 × 18 ... 16 AWG)
	Rigid	Screw connection: <ul style="list-style-type: none"> • 1 × 0.5 ... 4.0 mm² (1 × 20 ... 12 AWG) • 2 × 0.5 ... 2.5 mm² (2 × 20 ... 14 AWG) Easy Connect Technology (push-in): <ul style="list-style-type: none"> • 2 × 0.5 ... 1.5 mm² (2 × 20 ... 16 AWG)
Stripping length		8 mm (0.32 in)
Tightening torque		0.6 ... 0.8 Nm (7.08 lbf·in)
Environmental data		
Ambient temperature ranges	Operation	-25 °C ... +60 °C (-13 °F ... +140 °F)
	Storage	-40 °C ... +85 °C (-40 °F ... +185 °F)
Damp heat, cyclic (IEC/EN 60068-2-30)		6 x 24 h cycle, 55 °C, 95 % RH
Climatic class (IEC/EN 60721-3-3)		3K5 (no condensation, no ice formation)
Vibration, sinusoidal		5...13.2 Hz: ±1 mm; 13.2...100 Hz: 0.7 g
Shock		10 g / 11 ms
Approvals		
ATEX Ex II (2) G D UKEX (Pending)		
Isolation data		
Rated insulation voltage U_i	Supply circuit / Measuring circuit ¹⁾	300 V AC
	Supply circuit / Output circuits	300 V AC
	Measuring circuit ¹⁾ / Output circuits	300 V AC
	Output circuit 1 / Output circuit 2	300 V AC
Rated impulse withstand voltage U_{imp}	Supply circuit / Measuring circuit ¹⁾	4 kV
	Supply circuit / Output circuits	4 kV
	Measuring circuit ¹⁾ / Output circuits	4 kV
	Output circuit 1 / Output circuit 2	4 kV
Basic insulation	Supply circuit / Measuring circuit ¹⁾	600 V AC
	Supply circuit / Output circuits	600 V AC
	Measuring circuit ¹⁾ / Output circuits	600 V AC
	Output circuit 1 / Output circuit 2	300 V AC

Protective separation (IEC/EN 61140, EN 50178)	Supply circuit / Measuring circuit ¹⁾	yes, up to 300 V AC
	Supply circuit / Output circuits	yes
	Measuring circuit ¹⁾ / Output circuits	yes
	Output circuit 1 / Output circuit 2	no
Pollution degree		3
Overvoltage category		III

¹⁾ Potential of measuring circuit = Potential of control circuit

For the full relay technical data, see the CM-MSS.41 data sheet ([2CDC112216D0201 \[English\]](#)).

■ DOLD MK 9163N.12/110-ATEX

Ordering information		
Part number		0056901
Power supply A1...A2		
Rated voltage		24 V AC/DC
Voltage range		AC 0.8 ... 1.1 U
	at 10% residual ripple	DC 0.9 ... 1.25 U _H
	at 48% residual ripple	DC 0.8 ... 1.1 U _H
Nominal consumption	AC	1.5 VA
	DC	0.85 W
Nominal frequency		50 / 60 Hz
Frequency range		45 ... 65 Hz
Max. bridging time on failure of aux. supply		20 ms
Operate delay		< 40 ms
Release delay		< 100 ms
Measuring circuit P1...P2		
Response value		3.2 ... 3.8 kohm
Release value		1.5 ... 1.8 kohm
Broken wire detection		> 3.8 kohm
Short-circuit on measuring circuit		< 20 ohm
Loading of measuring circuit		< 5 mW (R = 1.5 kohm)
Measuring voltage		≤ 2 V (R = 1.5 kohm)
Maximum wire length	4 mm ²	2 × 550 m
	2.5 mm ²	2 × 250 m
	1.5 mm ²	2 × 150 m
	0.5 mm ²	2 × 50 m
Reset circuit X1...X2		
Function		External remote reset X1-X2 with NO contact (voltage free)

70 Technical data

Remark	This input is not galvanic separated from measuring input P1-P2	
Output contacts		
Contacts	2 changeover contacts	
Thermal current I_{th}	5 A	
Switching capacity (IEC/EN 60947-5-1)	to AC 15	3 A / AC 230 V
	to DC 13	2 A / DC 24 V
Electrical life at 4 A, 230 V AC, $\cos \phi = 0.6$	1.5×10^6 switching cycles	
Short-circuit strength (IEC/EN 60947-5-1)	NC contact	max. fuse rating: 6 A gG / gL
	NO contact	max. fuse rating: 10 A gG / gL
Mechanical life	$\geq 30 \times 10^6$ switching cycles	
Terminals		
Wire size	Stranded ferruled	1 × 0.5 ... 2.5 mm ² (2 × 20 ... 14 AWG) 2 × 0.5 ... 1.5 mm ² (2 × 20 ... 16 AWG)
	Solid	1 × 0.5 ... 4 mm ² (1 × 20 ... 12 AWG) 2 × 0.5 ... 2.5 mm ² (2 × 20 ... 14 AWG)
Tightening torque	Max. 0.8 Nm (7 lbf-in)	
Indicators		
Green LED	on, when auxiliary supply connected	
Red LED	on, when overtemperature or broken wire, short circuit is detected	
General data		
Operating mode	Continuous operation	
Temperature range	Operation	-20 °C ... +60 °C (-4 °F ... +140 °F)
	Storage	-20 °C ... +60 °C (-4 °F ... +140 °F)
Altitude	< 2000 m	
EMC (EN 55011)	Interference suppressions	Limit value class B
Degree of protection (IEC/EN 60529)	Housing	IP40
	Terminals	IP20
Housing	Thermoplastic with V0-behavior according to UL subject 94	
Climate resistance (IEC/EN 60068-1)	20 / 060 / 04	
Vibration resistance (IEC/EN 60068-2-6)	Amplitude 0.2 mm, frequency 10 ... 55 Hz	
Mounting (IEC/EN 60715)	DIN rail	
Weight	160 g (0.35 lbs)	
Dimensions	22.5 mm × 90 mm × 102 mm (0.89 in × 3.54 in × 4.02 in)	
Approvals		
ATEX Ex II (2) G D UKEX (Pending)		
Isolation data		
Note: The supply and measurement circuits are not electrically isolated. Use a dedicated power supply for the PTC relay(s).		
Rated impulse withstand voltage between all isolated circuits	4 kV	

Pollution degree	2
------------------	---

For the full relay technical data, see www.dold.com.

Pt100 relays

■ GM International D5273S

Ordering information	
Model	D5273S
Configuration tool	PPC5092
Power supply (terminals 9...10)	
Rated voltage	24 V DC reverse polarity protected
Voltage range	18...30 V DC
Power consumption	1.7 W (72 mA) at 24 V supply voltage, with 20 mA output and relays energized, typical
Measuring circuit (terminals 13...16)	
Sensor type	2-3-4 wire RTD Pt100 (for other alternatives, see the relay data sheet)
Integration time	50...500 ms
Resolution	1 μ V on mV/TC, 1 mohm on RTD/resistance, 0.0001% on potentiometer.
Visualization	0.1 $^{\circ}$ C on temperature, 10 μ V on mV, 100 mohm on resistance, 0.1% on potentiometer
Input range	-500...+500 mV for TC/mV, 0...4 kohm for resistance
Measuring RTD current	\leq 0.15 mA
Current output (terminals 11...12)	
Signal range (span)	0/4...20 mA, on max. 300 ohm load source mode, current limited at 24 mA
Resolution	1 μ A current output
Transfer characteristic	Linear, direct or reverse
Response time	\leq 20 ms (10...90% step change)
Output ripple	\leq 20 mVrms on 250 ohm load
Output contacts (terminals 1...3)	
Number of contacts	Two voltage-free SPDT relay contacts (NO and NC)
Hysteresis	Within rated limits of input sensor
ON-OFF delay time	0...1000 s, 100 ms step
Contact rating	4 A / 250 V AC / 1000 VA 4 A / 250 V DC / 120 W (resistive load)
Contact rating (UL)	1 A / 24 V DC 220 mA / 125 V DC 110 mA / 250 V DC

72 Technical data

Performance		
Reference conditions: 24 V supply, 250 ohm load, 23 ±1 °C ambient temperature, slow integration speed, 4 wire configuration for RTD		
Input	Calibration and linearity accuracy (standard)	≤ ± 10 µV on mV, 200 mohm on RTD, 0.1% on potentiometer
	Calibration and linearity accuracy (extended)	≤ ± 100 µV on mV, 400 mohm on RTD
	Temperature influence (standard)	≤ ± 3 µV on mV, 20 mohm on RTD, 0.02% on potentiometer for a 1 °C change
	Temperature influence (extended)	≤ ± 20 µV on mV, 200 mohm on RTD for a 1 °C change
Analog Output	Calibration accuracy	≤ ± 10 µA
	Linearity accuracy	≤ ± 10 µA
	Supply voltage influence	≤ ± 0.02% of full scale for a min to max supply change
	Load influence	≤ ± 0.02% of full scale for a 0...100% load resistance change
	Temperature influence	≤ ± 0.02 µA for a 1 °C change
Signalling LEDs	PWR	Power supply indication (green)
	FLT	Burnout (red)
	ALR A	Alarm A (red)
	ALR B	Alarm B (red)
Environmental conditions		
Operating	Temperature limits -40 °C ... +70 °C (-40 °F ... +158 °F), relative humidity max. 95%, up to 55 °C (131 °F).	
Storage	Temperature limits -45 °C ... +80 °C (-49 °F ... +176 °F)	
Maximum altitude	2000 m (6562 ft)	
General		
Mounting	EN/IEC 60715 TH 35 DIN-Rail	
Dimensions (Height × Width × Depth)	120 mm × 22.5 mm × 123 mm (4.72 in × 0.89 in × 4.84 in)	
Weight	approximately 195 g (0.43 lbs)	
Terminal connection	Screw terminal blocks, maximum conductor size 2.5 mm ² (13 AWG)	
Protection class	IP20	
Approvals		
<ul style="list-style-type: none"> • ATEX Ex II (1) G D • UL, cUL • EAC Ex • IECEX • TÜV Certificate No. C-IS-722160171, SIL 2 conforms to IEC 61508:2010 Ed.2 • DNV Type Approval Certificate No. TAA00001U0 and KR No.MIL20769-EL002 Certificates for maritime applications. <p>For the full list of approvals, see the relay instruction manual.</p>		

Isolation data		
Isolation voltage (Test voltage)	In/Outs	2.5 kV
	In/Supply	2.5 kV
	Out/Supply	500 V
	Out/Alarms	1.5 kV
	Alarms/Supply	1.5 kV
	Alarms/Alarms	1.5 kV

For the full relay technical data, see www.gminternational.com.

■ PR electronics 9116B1 universal converter

Ordering information		
Universal converter - U _o 28 V DC (max. loop voltage)		9116B1
Display / Programming front (not included in the ABB delivery)		4501
Power supply (terminals 32...31)		
Supply voltage		19.2 ... 31.2 V DC
Fuse		1.25 A SB / 250 V AC
Maximum required power		≤ 2.1 W
Maximum power dissipation		≤ 1.7 W
Measuring circuit/RTD input (terminals 41...44)		
Sensor type		3-4 wire RTD Pt100 (for other alternatives, see the relay data sheet)
Effect of sensor cable resistance (3-/4-wire)		< 0.002 ohm / ohm
Sensor error detection		Programmable ON / OFF
Short circuit detection		Yes
Cable resistance per wire (max)		50 ohm
Sensor current (nominal)		0.2 mA
Current output (terminals 12...11)		
Signal range (span)		0 ... 23 mA
Programmable signal ranges		0/4 ... 20 mA
Load (at current output)		≤ 600 ohm
Load stability		≤ 0.01% of span / 100 ohm
Sensor error indication		0 / 3.5 / 23 mA / none
NAMUR NE43 Upscale/Downscale		23 mA / 3.5 mA
Output limitation	on 4...20 and 20...4 mA signals	3.8 ... 20.5 mA
	on 0...20 and 20...0 mA signals	0 ... 20.5 mA
Current limit		≤ 28 mA
Relay output (terminals 13...14)		
Relay functions		Setpoint, Window, Sensor error, Power and Off
Hysteresis, in % of span/display range		0.1...25 / 1...25
ON-OFF delay time		0 ... 3600 s

74 Technical data

Sensor error reaction		Break / Make / Hold
Max. voltage		250 V AC/DC
Max. current		2 A
Max. AC power		500 VA
Max. DC current	resistive load ≤ 30 V DC	2 A DC
	resistive load > 30 V DC	See the relay manual
Indication of operating states		
Operation status		LED (green)
Relay status		“relay” LED (yellow)
Malfunction		“error” LED (red)
Environmental conditions		
Operating temperature		-20 °C ... +60 °C (-4 °F ... +140 °F)
Storage temperature		-20 °C ... +85 °C (-4 °F ... +185 °F)
Calibration temperature		20 ... 28 °C (68 °F ... 82 °F)
Relative humidity		< 95% RH (non-cond.)
Protection degree		IP20
Installation in		Pollution degree 2 & meas. / overvoltage cat. II
Mechanical specifications		
Dimensions (Height × Width × Depth)	Without 4501	109 mm × 23.5 mm × 104 mm (4.29 in × 0.93 in × 4.09 in)
	With 4501	109 mm × 23.5 mm × 116 mm (4.29 in × 0.93 in × 4.57 in)
Weight		approximately 185 g (0.41 lbs)
Weight including 4501		approximately 200 g (0.44 lbs)
Terminals	Wire size	0.13 ... 2.08 mm ² (AWG 26 ... 14) stranded wire
	Tightening torque	0.5 N·m (4.4 lbf·in)
Vibration	2 ... 13.2 Hz	±1 mm
	13.2 ... 100 Hz	±0.7 g
Approvals		
<ul style="list-style-type: none"> • ATEX Ex II (1) G D • UKEX (Pending) • IECEX • EAC Ex • SIL 2 certified according to IEC 61508 <p>For the full list of approvals, see the relay data sheet.</p>		
Isolation data		
Isolation voltage	Test/working: Input to any	2.6 kV AC / 300 V AC reinforced isolation
	Analog output to supply	2.6 kV AC / 300 V AC reinforced isolation
	Status relay to supply	1.5 kV AC / 150 V AC reinforced isolation

For the full relay technical data, see www.prelectronics.com.

Markings of the drive

1	CE marking with Notified Body identification: The manufacturer declares that the product conforms with ATEX Product Directive 2014/34/EU. Notified Body: Eurofins Expert Services
2	UKCA marking with Approved Body identification: The manufacturer declares that the product conforms with The Equipment and Protective Systems Intended for Use in Potentially Explosive Atmospheres Regulations 2016 (+ amendment SI 2019 No. 696). Approved Body: Eurofins E&E CML Limited
3	Specific marking of explosion protection
4	Equipment group II: Product for surface industry (other than mining applications)
5	Equipment category 2. Parentheses show that the drive (or inverter unit) must be installed outside the potentially explosive atmosphere.
6	Certified for use in explosive atmospheres caused by: G = gases, vapors or mists, D = dust.
7	Certificate references
8	QR code (with the factory code and tracing information)
3AXD50000003122 E	

Ambient conditions

For the environmental limits for the safety functions and the drive, refer to the hardware manual.

Related standards and directives

EN 50495:2010	Safety devices required for the safe functioning of equipment with respect to explosion risks
IEC 61508:2010	Functional safety of electrical/electronic/programmable electronic safety-related systems. Part 1 – General Requirements Part 2 – Requirements for electrical/electronic/programmable electronic safety-related systems
EN 61800-5-2:2007 IEC 61800-5-2:2016	Adjustable speed electrical power drive systems – Part 5-2: Safety requirements – Functional
EN IEC 62061:2021	Safety of machinery – Functional safety of safety-related control systems

76 Technical data

IEC 61511-1:2017 Ed.2.1	Functional safety – Safety instrumented systems for the process industry sector – Part 1: Framework, definitions, system, hardware and application programming requirements
2014/34/EU	ATEX Product Directive (EU)
	The Equipment and Protective Systems Intended for Use in Potentially Explosive Atmospheres Regulations 2016 (+ amendment SI 2019 No. 696) (UK)

ATEX certificate



EESF 20 ATEX 049 Issue 1
Page 1 of 2

EU-TYPE EXAMINATION CERTIFICATE

- 1.
2. **Equipment or Protective System Intended for use in Potentially explosive atmospheres
Directive 2014/34/EU**
3. EU-Type Examination Certificate Number: **EESF 20 ATEX 049 Issue 1**
4. Product: **Thermal motor protection system for converter drive ACS880/ACS880LC series**
 Certified types: **ACS880/ACS880LC +L513 +Q971**
ACS880/ACS880LC +L514 +Q971
ACS880/ACS880LC +L513/+L514 +Q971 +Q973 (FSO-12)
ACS880/ACS880LC +L513/+L514 +Q971 +Q972 (FSO-21)
ACS880/ACS880LC +L513/+L514 +Q971 +Q972 +L521 (FSO-21 & FSE-31)
5. Manufacturer: **ABB Oy Drives**
6. Address: **Hiomotie 13, 00380 Helsinki, Finland**
 Additional manufacturing locations:
ABB AS, Drives, Aruküla tee 59, Rae vald, 75301 Harjumaa, Estonia
7. This product and any acceptable variation thereto is specified in the schedule to this certificate and the documents therein referred to.
8. Eurofins Electric & Electronics Finland Oy, Notified Body number 0537, in accordance with Article 17 of Directive 2014/34/EU of the European Parliament and of the Council, dated 26 February 2014, certifies that this product has been found to comply with the Essential Health and Safety Requirements relating to the design and construction of products intended for use in potentially explosive atmospheres given in Annex II to the Directive.
 The examination and test results are recorded in confidential report No. EUFI29-23003043-T1.
9. Compliance with the Essential Health and Safety Requirements has been assured by compliance with:
EN 50495:2010
10. If the sign "X" is placed after the certificate number, it indicates that the product is subject to the Specific Conditions of Use specified in the schedule to this certificate.
11. This EU-Type Examination Certificate relates only to the design and construction of the specified product. Further requirements of the Directive apply to the manufacturing process and supply of this product. These are not covered by this certificate.
12. The marking of the product shall include the following:



Espoo, 20.12.2023
Eurofins Electric & Electronics Finland Oy

Kari Koskela
Senior Expert

Jenni Hirvelä
Senior Expert

This document is digitally signed.



13. **Schedule**

 14. **EU-Type Examination Certificate EESF 20 ATEX 049 Issue 1**

 15. **Description of Product**

Thermal protection is based on ATEX-certified PTC- relay (type L513) or Pt100-relay (type L514). Safe disconnection is achieved by using "Safe Torque Off "(STO)-function which is integrated in the standard drive as an internal hardware-solution. Power that can cause rotation is not applied to the motor. The safety related part of the adjustable speed electrical power drive system PDS (SR) will not provide energy to the motor which can generate torque.

 16. **Report Number**

EUFI29-23003043-T1

 17. **Specific Conditions of Use**

None

 18. **Essential Health and Safety Requirements**

Assessment using standard referred in point 9 have confirmed compliance with the Directive 2014/34/EU, Annex II and particular point 1.5.

 19. **Drawings and Documents**

ACS880 ATEX-certified motor thermal protection functions system description, 3AXD10000331764, rev D
 ACS880 ATEX-certified motor thermal protection functions safety data calculations, 3AXD10000331763, rev G
 ACS880+L513 & +L514 ATEX-circuits diagrams, 3AXD10000363564, rev D
 Certificate No. SEBS-A.093457/16 V2.0 by TÜV Nord
 Certificate No. 1435.IM.153902/19 V1.0 by TÜV Nord

 20. **Certificate History**

Issue	Date	Change
VTT 14 ATEX 027	3.5.2013	Prime certificate
VTT 14 ATEX 027 Issue 1	1.3.2016	The introduction of new manufacturing places and a new PTC-relay
VTT 14 ATEX 027 Issue 2	30.6.2017	The introduction of a new converter type and deleting one manufacturing place. Updating the certificate according to the new directive.
EESF 20 ATEX 049	30.10.2020	Updates to safety data calculations and circuit diagrams, FSO-12 and FSO-21 TÜV Nord certificates have been combined into one certificate, one manufacturing location has been removed.
EESF 20 ATEX 049 Issue 1	20.12.2023	New Pt100 relay and related updates in the documentation. STO certificate by TÜV Nord has been renewed.

UKEX certificate



UK Type Examination Certificate CML 21UKEX9299 Issue 1

United Kingdom Conformity Assessment

- 1 Product or Protective System Intended for use in Potentially Explosive Atmospheres UKSI 2016:1107 (as amended) – Schedule 3A, Part 1
- 2 Equipment **Thermal motor protection system for converter drive ACS880/ACS880LC series**
ACS880/AC880LC +L513 +Q971
ACS880/AC880LC +L514 +Q971
ACS880/AC880LC +L513/+L514 +Q971 +Q973 (FSO-12)
ACS880/AC880LC +L513/+L514 +Q971 +Q972 (FSO-21)
ACS880/AC880LC +L513/+L514 +Q971 +Q972 +L521 (FSO-21 & FSE-31)

 Applicant **ABB Oy Drives**
 Address **Hiomotie 13,**
00380 Helsinki,
Finland
- 3 Manufacturer **ABB Oy Drives** **ABB AS, Drives**
- 4 Address **Hiomotie 13,** **Aruküla tee 59,**
00380 Helsinki, **Rae vald, 75301 Harjumaa,**
Finland **Estonia**
- 5 The equipment is specified in the description of this certificate and the documents to which it refers.
- 6 Eurofins E&E CML Limited, Newport Business Park, New Port Road, Ellesmere Port, CH65 4LZ, United Kingdom, Approved Body Number 2503, in accordance with Regulation 42 of the Equipment and Protective Systems Intended for Use in Potentially Explosive Atmospheres Regulations 2016, UKSI 2016:1107 (as amended), certifies that this equipment has been found to comply with the Essential Health and Safety Requirements relating to the design and construction of equipment intended for use in potentially explosive atmospheres given in Schedule 1 of the Regulations.
 The examination and test results are recorded in the confidential reports listed in Section 12.
- 7 If an 'X' suffix appears after the certificate number, it indicates that the equipment is subject to specific conditions of use (affecting correct installation or safe use). These are specified in Section 14.
- 8 This UK Type Examination certificate relates only to the design and construction of the specified equipment. Further requirements of the Regulations apply to the manufacturing process and supply of the product. These are not covered by this certificate.
- 9 Compliance with the Essential Health and Safety Requirements, with the exception of those listed in the confidential report, has been demonstrated through compliance with the following documents:
 EN 50495:2010
- 10 The equipment shall be marked with the following:
 Refer to attached certificate EESF 20 ATEX 049, Issue 1 for specific marking of explosion protection symbols.
 Refer to attached certificate EESF 20 ATEX 049, Issue 1 for marked code and ambient temperature range.



This certificate shall only be copied in its entirety and without change
www.CMLEx.com

S. Roumbedakis
 Technical Manager



11 Description

For product description refer to attached certificate EESF 20 ATEX 049, Issue 1.

Variation 1

This variation introduced the following modification:

- i. New Pt100 relay and related updates in the documentation. STO certificate by TÜV Nord has been renewed.

12 Certificate history and evaluation reports

Issue	Date	Associated report	Notes
0	21 Jun 2021	R14004B/00	Issue of the prime certificate. EESF 20 ATEX 049 Issue 0 is attached and shall be referred to in conjunction with this certificate.
1	16 Jan 2024	R17302B/00	Issue of the variation certificate. EESF 20 ATEX 049, Issue 1 is attached and shall be referred to in conjunction with this certificate.

Note: Drawings that describe the equipment are listed or referred to in the Annex.

13 Conditions of Manufacture

For conditions of manufacture, refer to attached certificate EESF 20 ATEX 049, Issue 1.

Any routine tests/verifications required by the ATEX certification shall be conducted.

14 Specific Conditions of Use

For specific conditions of use, refer to attached certificate EESF 20 ATEX 049, Issue 1.

Declaration of Conformity (EU)



EU Declaration of Conformity

ATEX Directive 2014/34/EU

We

Manufacturer: ABB Oy

Address: Hiomotie 13, 00380 Helsinki, Finland.

Phone: +358 10 22 11

declare under our sole responsibility that the following products:

Frequency converters

ACS880-07, -17, -37, -107

ACS880-07CLC, -07LC, -17LC, -37LC, -107LC

identified with serial numbers beginning with 1 or 8

with regard to the safety function

ATEX certified thermal motor protection (option codes +L513 +Q971, +L514 +Q971)

are in conformity with all the relevant requirements for protective system of EU Directive for Equipment for Explosive atmospheres 2014/34/EU.

Specific marking of explosion protection

 II (2) GD

The following harmonized standard has been applied:

EN 50495:2010	Safety devices required for the safe functioning of equipment with respect to explosion risks
---------------	---

The following other standards have been applied:

EN 61800-5-2:2007	Adjustable speed electrical power drive systems – Part 5-2: Safety requirements - Functional
IEC 61800-5-2:2016	
IEC 61508:2010, parts 1-2	Functional safety of electrical / electronic / programmable electronic safety-related systems

Notified Body: Eurofins Electric & Electronics Finland Oy, Notified Body number: 0537, Address: Kivimiehentie 4, 02150 Espoo, Finland

has assessed the conformity of the “ATEX certified thermal motor protection” function and has issued the certificate EESF 20 ATEX 049.



—
The products referred in this Declaration of conformity fulfil the relevant provisions of other European Union Directives which are notified in Single EU Declaration of conformity 3AXD10000497305.

Helsinki, 19 Jun 2023

Signed for and on behalf of:

Peter Lindgren
Peter Lindgren
Vice President, ABB Oy

Vesa Tiihonen
Vesa Tiihonen
Manager, Reliability and Quality, ABB Oy

If you need the Declaration of Conformity in an official language of the European Union other than English, contact ABB.

Declaration of Conformity (UK)



Declaration of Conformity

The Equipment and Protective Systems Intended for Use in Potentially Explosive Atmospheres Regulations 2016 (+ amendment SI 2019 No. 696)

We

Manufacturer: ABB Oy

Address: Hiomotie 13, 00380 Helsinki, Finland.

Phone: +358 10 22 11

declare under our sole responsibility that the following products:

Frequency converters

ACS880-07, -17, -37, -107

ACS880-07CLC, -07LC, -17LC, -37LC, -107LC

identified with serial numbers beginning with 1 or 8

with regard to the safety function

ATEX certified thermal motor protection (option codes +L513 +Q971, +L514 +Q971)

are in conformity with all the relevant requirements for protective system of The Equipment and Protective Systems Intended for Use in Potentially Explosive Atmospheres Regulations 2016 (+ amendment SI 2019 No. 696).

Specific marking of explosion protection



The following designated standard has been applied:

EN 50495:2010	Safety devices required for the safe functioning of equipment with respect to explosion risks
---------------	---

The following other standards have been applied:

EN 61800-5-2:2017	Adjustable speed electrical power drive systems – Part 5-2: Safety requirements - Functional
IEC 61800-5-2:2016	
IEC 61508:2010, parts 1-2	Functional safety of electrical / electronic / programmable electronic safety-related systems



Approved Body: Eurofins E&E CML Limited, Approved Body number: 2503, Address: Newport Business Park, New Port Road, CH65 4LZ, Ellesmere Port, United Kingdom

has assessed the conformity of the "ATEX certified thermal motor protection" and has issued the certificate CML 21 UKEX 9299.

The products referred in this Declaration of conformity fulfil the relevant provisions of other UK Legislation which are notified in Single UK Declaration of conformity 3AXD10001346556.

Helsinki, 19 Jun 2023

Signed for and on behalf of:

Peter Lindgren

Peter Lindgren
Vice President, ABB Oy

Vesa Tiihonen

Vesa Tiihonen
Manager, Reliability and Quality, ABB Oy

Further information

Product and service inquiries

Address any inquiries about the product to your local ABB representative, quoting the type designation and serial number of the unit in question. A listing of ABB sales, support and service contacts can be found by navigating to www.abb.com/contact-centers.

Product training

For information on ABB product training, navigate to new.abb.com/service/training.

Providing feedback on ABB manuals

Your comments on our manuals are welcome. Navigate to new.abb.com/drives/manuals-feedback-form.

Document library on the Internet

You can find manuals and other product documents in PDF format on the Internet at www.abb.com/drives/documents.



www.abb.com/drives



3AXD50000014979G