

ABB DRIVES FOR WATER

## **ACQ580-xP 3R Irrigation Drive Package**

Supplement Installation Manual for  
ACQ580-xP 3R Irrigation Drive Package

ACQ580-0P...+C192+F289 3R Irrigation drive package (230V, 25-100 HP; 480V, 40-200 HP)  
and  
ACQ580-3P...+C192+F289 3R Irrigation drive package (480V, 40-150 HP)



## **Table of Contents**

<b>Safety instructions</b> .....	<b>2</b>
Use of warnings and notes in this manual .....	2
General safety in installation, start-up and maintenance .....	2
Electrical safety in installation, start-up and maintenance .....	3
<b>Electrical safety precautions</b> .....	<b>3</b>
Additional instructions and notes .....	4
Printed circuit boards .....	5
Grounding .....	5
Additional Instructions for permanent magnet motor drives .....	5
General safety in operation .....	6
Cybersecurity disclaimer .....	6
<b>Contents</b> .....	<b>7</b>
Drive identification .....	7
<b>Installation</b> .....	<b>9</b>
Mounting the drive .....	9
Installing the wiring .....	10
Connection diagrams .....	10
Power connection terminals .....	12
Branch circuit protection .....	12
<b>Operation</b> .....	<b>12</b>
Irrigation specific home screens .....	13
How to start up the drive using First start assistant .....	13
Irrigation primary settings .....	18
Irrigation total flow accumulated feature .....	19
Default I/O connection diagrams .....	20
<b>Optional floor kit mounting</b> .....	<b>21</b>
Floor kit identification .....	22
Enclosure M3R-32W .....	22
Enclosure M3R-40W .....	24
<b>Dimensions &amp; weights</b> .....	<b>26</b>
<b>Ambient conditions</b> .....	<b>27</b>
<b>Applicable standards</b> .....	<b>28</b>
<b>Maintenance intervals</b> .....	<b>28</b>
Drive module maintenance .....	28
Enclosure fan maintenance .....	28
Input voltage surge suppressor maintenance .....	28

## Safety instructions

These are the safety instructions which you must obey when you install and operate the drive and do maintenance on the drive. If you ignore the safety instructions, injury, death or damage can occur.

### ■ Use of warnings and notes in this manual

Warnings tell you about conditions which can cause injury or death, or damage to the equipment. They also tell you how to prevent the danger. Notes draw attention to a particular condition or fact or give information on a subject.

The manual uses these warning symbols:



**Electricity warning** tells about hazards from electricity which can cause injury or death, or damage to the equipment.

---



**General warning** tells about conditions, other than those caused by electricity, which can cause injury or death, or damage to the equipment.

---



**Electrostatic sensitive devices warning** tells you about the risk of electrostatic discharge which can cause damage to the equipment

---

### ■ General safety in installation, start-up and maintenance

These instructions are for all personnel that install the drive and do maintenance work on it.



**WARNING!** Obey these instructions. If you ignore them, injury or death, or damage to the equipment can occur.

---

- Use safety shoes with a metal toe cap to avoid foot injury. Wear protective gloves and long sleeves. Some parts have sharp edges.
  - Handle the drive carefully.
  - Beware of hot surfaces. Some parts, such as heatsinks of power semiconductors, remain hot for a while after disconnection of the electrical supply.
  - Keep the unit in its packaging until you install it. After unpacking, protect the drive module from dust, debris and moisture.
  - Also protect the installed drive against dust and burrs. Electrically conductive debris inside the drive may cause damage or malfunction.
  - Vacuum clean the area below the drive before the start-up to prevent the drive cooling fan from drawing the dust inside the drive.
  - Do not cover the air inlet and outlet when the drive runs.
  - Make sure that there is sufficient cooling.
  - See the ACQ580-01 Hardware Manual ([3AXD50000044862](#)) or ACQ580-31 Hardware Manual ([3AXD50000045935](#)) for more information.
  - Before you connect voltage to the drive, make sure that the doors are closed. Keep the doors closed during the operation.
  - Before you adjust the drive operation limits, make sure that the motor and all driven equipment can operate throughout the set operation limits.
  - Before you activate the automatic fault reset or automatic restart functions of the drive control program, make sure that no dangerous situations can occur. These functions reset
-

the drive automatically and continue operation after a fault or supply break. If these functions are activated, the installation must be clearly marked as defined in IEC/EN 61800-5-1, subclause 6.5.3, for example, “THIS MACHINE STARTS AUTOMATICALLY”.

- The maximum number of drive power-ups is five in ten minutes. Too frequent power-ups can damage the charging circuit of the DC capacitors.
- If you have connected safety circuits to the drive (for example, emergency stop and Safe torque off), validate them at the start up. For the validation of the Safe torque off, see ACQ580 pump control program firmware manual ([3AXD50000035867](#)). For the validation of other safety circuits, see the instructions provided with them.

Note:

- If you select an external source for start command and it is on, and the start command is level-triggered, the drive will start immediately after fault reset. See parameters 20.02 Ext1 start trigger type and 20.07 Ext2 start trigger type in ACQ580 pump control program firmware manual ([3AXD50000035867](#)).
- Depending on the wiring and parametrization of the drive, the stop key on the control panel may not stop the drive.
- Do not attempt to repair a malfunctioning drive; contact your local ABB representative in regard to malfunctioning drive.

## ■ Electrical safety in installation, start-up and maintenance

### Electrical safety precautions

These warnings are for all personnel who do work on the drive, motor cable or motor.



**WARNING!** Obey these instructions. If you ignore them, injury or death, or damage to the equipment can occur. If you are not a qualified electrical professional, do not do electrical installation or maintenance work. Go through these steps before you begin any installation or maintenance work.

---

1. Clearly identify the work location and equipment.
  2. Disconnect all possible voltage sources. Make sure that re-connection is not possible. Lock out and tag out.
    - Open the main disconnect at the power supply of the drive.
    - Open the disconnect of the supply transformer.
    - Disconnect any external power sources from the control circuits.
    - After you disconnect the drive, always wait for 5 minutes to let the intermediate circuit capacitors discharge before you continue.
  3. Protect any other energized parts in the work location against contact.
  4. Take special precautions when close to bare conductors.
  5. Measure that the installation is de-energized. If the measurement requires removal or disassembly of shrouding or other cabinet structures, obey the local laws and regulations applicable to live working (including – but not limited to – electric shock and arc protection).
    - Use a multimeter with an impedance of at least 1Mohm. Before and after measuring the installation, verify the operation of the voltage tester on a known voltage source.
    - Make sure that the voltage between the drive input power terminals (L1, L2, L3) and the grounding terminal (PE) is 0 V.
    - Make sure that the voltage between the drive output terminals (T1/U, T2/V, T3/W) and the grounding (PE) busbar is 0 V.
-

- Make sure that the voltage between the drive DC terminals (UDC+ and UDC-) and the grounding terminal (PE) is close to 0 V.
- 6. Install temporary grounding as required by the local regulations.
- 7. Ask for a permit to work from the person in control of the electrical installation work

If the drive does not operate according to these steps, refer to the ACQ580-01 Hardware Manual ([3AXD50000044862](#)) or ACQ580-31 Hardware Manual ([3AXD50000045935](#)).

#### ■ Additional instructions and notes



**WARNING!** Obey these instructions. If you ignore them, injury or death, or damage to the equipment can occur. If you are not a qualified electrical professional, do not do installation or maintenance work.

---

- A drive with the internal EMC filter connected can be installed to a symmetrically grounded TN-S system. If you install the drive to another system, check if you must disconnect the EMC filter. Refer to the ACQ580-01 Hardware Manual ([3AXD50000044862](#)) or ACQ580-31 Hardware Manual ([3AXD50000045935](#)).



**WARNING!** Do not install a drive with the EMC filter connected to a system that the filter is not suitable for. This can cause danger, or damage the drive.

---

**Note:** When the internal EMC filter is disconnected, the EMC compatibility of the drive is considerably reduced.

- A drive with the ground-to-phase varistor connected can be installed to a symmetrically grounded TN-S system. If you install the drive to another system, check if you must disconnect the varistor. Refer to the ACQ580-01 Hardware Manual ([3AXD50000044862](#)) or ACQ580-31 Hardware Manual ([3AXD50000045935](#)).



**WARNING!** Do not install a drive with the ground-to-phase varistor connected to a system that the varistor is not suitable for. If you do, the varistor circuit can be damaged.

---

- Use all ELV (extra low voltage) circuits connected to the drive only within a zone of equipotential bonding, that is, within a zone where all simultaneously accessible conductive parts are electrically connected to prevent hazardous voltages appearing between them. You can accomplish this by a proper factory grounding, that is, make sure that all simultaneously accessible conductive parts are grounded to the ground / protective earth (PE) bus of the building.
- Do not do insulation or voltage withstand tests on the drive or drive modules.
- Keep the cabinet doors closed when the drive is powered. With the doors open, a risk of a potentially fatal electric shock, arc flash or high-energy arc blast exists.
- Make sure that the electrical power network, motor/generator, and environmental conditions agree with the drive data.
- If you have a cardiac pacemaker or other electronic medical device, keep away from the area near motor, drive, and the drive power cabling when the drive is in operation. There are electromagnetic fields present which can interfere with the function of such devices. This can cause a health hazard.

Note:

- The motor cable terminals of the drive are at a dangerous voltage when the input power is on, regardless of whether the motor is running or not.
  - The DC terminals (UDC+, UDC-) are at a dangerous voltage.
-

- External wiring can supply dangerous voltages to the terminals of relay outputs (RO1, RO2 and RO3).
- The Safe torque off function does not remove the voltage from the main and auxiliary circuits. The function is not effective against deliberate sabotage or misuse.

### ■ Printed circuit boards



**WARNING!** Use a grounding wrist band when you handle printed circuit boards. Do not touch the boards unnecessarily. The boards contain components sensitive to electrostatic discharge.

---

### ■ Grounding

These instructions are for all personnel who are responsible for the electrical installation, including the grounding of the drive.



**WARNING!** Obey these instructions. If you ignore them, injury or death, or equipment malfunction can occur, and electromagnetic interference can increase. If you are not a qualified electrical professional, do not do grounding work.

---

- Always ground the drive, the motor and adjoining equipment to the ground/ protective earth (PE) bus of the power supply. This is necessary for the personnel safety. Proper grounding also reduces electromagnetic emission and interference.
- In a multiple-drive installation, connect each drive separately to the ground / protective earth (PE) bus of the power supply.
- Make sure that the conductivity of the ground/ protective earth (PE) conductors is sufficient. See the electrical planning instructions of the drive. Obey the local regulations.
- Connect the power cable shields to the ground / protective earth (PE) terminals of the drive.
- Make a 360° grounding of the power and control cable shields at the cable entries to suppress electromagnetic disturbances.

Note:

- You can use power cable shields as grounding conductors only when their conductivity is sufficient.
- As the normal touch current of the drive is higher than 3.5mA AC or 10mA DC, you must use a fixed protective earth (PE) connection. The minimum size of the protective earth conductor must comply with the local safety regulations for high protective earth conductor current equipment. See standard IEC/EN 61800-5-1 (UL 61800-5-1) and the electrical planning instructions of the drive.

### ■ Additional Instructions for permanent magnet motor drives

Safety in installation, start-up and maintenance

These are additional warnings concerning permanent magnet motor drives. The other safety instructions in this chapter are also valid.



**WARNING!** Obey these instructions. If you ignore them, injury or death and damage to the equipment can occur.

---

- Do not work on a drive when a rotating permanent magnet motor is connected to it. A rotating permanent magnet motor energizes the drive including its input power terminals.

Before installation, start-up and maintenance work on the drive:

- Stop the motor.
- Disconnect the motor from the drive with a safety switch or by other means.
- If you cannot disconnect the motor, make sure that the motor cannot rotate during work. Make sure that no other system can rotate the motor directly or through any mechanical connection.
- Measure that the installation is de-energized.
  - Use a multimeter with an impedance of at least 1Mohm.
  - Make sure that the voltage between the drive output terminals (T1/U, T2/V, T3/W) and the grounding (PE) busbar is close to 0V
  - Make sure that the voltage between the drive input power terminals (L1, L2, L3) and the grounding (PE) busbar is close to 0V.
  - Make sure that the voltage between the drive DC terminals (UDC+, UDC-) and the grounding (PE) terminal is close to 0V.
- Install temporary grounding as required by the local regulations.

Start-up and operation:

- Make sure that the motor cannot be run into overspeed, e.g. driven by the load. Motor overspeed causes overvoltage that can damage or destroy the capacitors in the intermediate circuit of the drive.

#### ■ General safety in operation

These instructions are for all personnel that operate the drive.



**WARNING!** Obey these instructions. If you ignore them, injury or death, or damage to the equipment can occur.

---

- Do not power up the drive more than five times in ten minutes. Too frequent power-ups can damage the charging circuit of the DC capacitors. If you need to start or stop the drive, use the control panel Hand, Off and Auto keys or commands through the I/O terminals of the drive.
- Give a stop command to the drive before you reset a fault. If you have an external source for the start command and the start is on, the drive will start immediately after the fault reset, unless you configure the drive for pulse start. See the firmware manual.
- Before you activate automatic fault reset functions of the drive control program, make sure that no dangerous situations can occur. These functions reset the drive automatically and continue operation after a fault.

#### ■ Cybersecurity disclaimer

This product is designed to be connected to and to communicate information and data via a network interface. It is Customer's sole responsibility to provide and continuously ensure a secure connection between the product and Customer network or any other network (as the case may be). Customer shall establish and maintain any appropriate measures (such as but not limited to the installation of firewalls, application of authentication measures, encryption of data, installation of anti-virus programs, etc) to protect the product, the network, its system and the interface against any kind of security breaches, unauthorized access, interference, intrusion, leakage and/or theft of data or information. ABB and its affiliates are not liable for damages and/or losses related to such security breaches, any unauthorized access, interference, intrusion, leakage and/or theft of data or information.

---

## Contents

This manual is the Installation Manual for ACQ580 irrigation drive packages. Complete technical details are available in the ACQ580-01 Hardware Manual ([3AXD50000044862](#)) or ACQ580-31 Hardware Manual ([3AXD50000045935](#)). Complete programming information is available in the ACQ580 pump control program firmware manual ([3AXD50000035867](#)).

### ■ Drive identification

To determine the type of your drive, refer to its construction code. Use the following to interpret the type code found on the identification label on the inside surface of the enclosure door.

*ACQ580-0P...+C192+F289, 3R irrigation drive package*

A	C	Q	5	8	0	-	0	P	-					-					+	C	1	9	2	+	F	2	8	9	+						
Product series					Construction			Size				Voltage				Standard Options						Options													

All option codes must be in alphanumeric order

A	C	Q	5	8	0
---	---	---	---	---	---

Product series

-	0	P
---	---	---

Base Drive Construction

Drive Package with input disconnect means

-				
---	--	--	--	--

Size

(Output current rating, see table below for details) Requires 4-digit Amp rating in type code

Voltage	Frame Size				
	R4	R5	R6	R7	R8
230 V	075A	088A	143A	169A	273A
		114A		211A	
460 V	052A	096A	124A	156A	240A
	065A			180A	
	077A				

-	
---	--

Voltage Rating

2 = 208/240 VAC

4 = 460 VAC

+	C	1	9	2
---	---	---	---	---

Standard (Plus Code)

Irrigation package: UL Type 3R enclosure with flange mounted ACQ Irrigation drive with Irrigation specific software; Service Entrance rated for three phase four wire power system, input voltage surge suppressor and condensation heater

+	F	2	8	9
---	---	---	---	---

Standard (Plus Code)

MCCB Circuit Breaker Input Disconnect without fuses (65 kA SCCR)

+				
---	--	--	--	--

Options (Plus Codes)

ACQ580-3P...+C192+F289, ULH 3R irrigation drive package

A	C	Q	5	8	0	-	3	P	-					-	4	+	C	1	9	2	+	F	2	8	9	+				
Product series					Construction			Size			Voltage			Standard Options						Options										

All option codes must be in alphanumeric order

**A C Q 5 8 0**

Product series

**- 3 P**

Base Drive Construction

Ultra-low harmonic drive package with input disconnect means

**-**

Size

(Output current rating, see table below for details) Requires 4-digit Amp rating in type code

Voltage	Frame Size	
	R6	R8
460 V	052A	096A
	065A	124A
	077A	156A
		180A

**- 4**

Voltage Rating

4 = 460 VAC

**+ C 1 9 2**

Standard (Plus Code)

Irrigation package: UL Type 3R enclosure with flange mounted ACQ Irrigation drive with Irrigation specific software; Service Entrance rated for three phase four wire power system, input voltage surge suppressor and condensation heater

**+ F 2 8 9**

Standard (Plus Code)

MCCB Circuit Breaker Input Disconnect without fuses (65 kA SCCR)

ACQ580-xP...+C192+F289 options

**ACQ580-xP Pilot Device Options**

---

G302

Hand-off-auto (HOA) switch

G303

Speed Potentiometer

**ACQ580-xP Control Power Transformer Options**

---

G304

Control transformer with 115 Vac, 1 phase secondary extra 100 VA to a fuse

## Installation

This information is unique to ACQ580 Irrigation Drive Packages (ACQ580-xP...+C192+F289). This includes an ACQ580 AC adjustable frequency drive with ABB irrigation specific software packaged in a UL type 3R enclosure with a molded case circuit breaker input disconnect, Service Entrance rating for three phase four wire power system, input voltage surge suppressor and condensation heater. Refer to the Electrical Installation - North America in the ACQ580 Hardware Manuals for all other information. **Failure to observe the warnings and instructions may cause malfunction or personal hazard.**



**WARNING!** Before you begin read [Safety instructions on Page 2](#).



**WARNING!** When the ACQ580 irrigation drive package is connected to the line power, the Motor Terminals T1, T2, and T3 are live even if the motor is not running. Do not make any connections when the ACQ580 irrigation drive package is connected to the line. Disconnect and lock out power to the drive before servicing the drive. Failure to disconnect power may cause serious injury or death.

Table 1. Enclosure Designation

Frame	Light Duty HP	Enclosure Designation
<i>6-Pulse; 208/240 Volt Ratings</i>		
R4	20	M3R-32W
R5	30-40	
R6	50	M3R-40W
R7	60-75	
R8	100	
<i>6-Pulse; 480 Volt Ratings</i>		
R4	40-60	M3R-32W
R5	75	
R6	100	M3R-40W
R7	125-150	
R8	200	
<i>ULH; 480 Volt Ratings</i>		
R6	40-60	M3R-40W
R8	75-150	

### ■ Mounting the drive

The ACQ580 irrigation drive packages are designed to be mounted on a solid vertical surface or using UNISTRUT. An optional floor/ground mounting kit is available for purchase for both cabinet sizes. See section [Optional floor kit mounting on Page 21](#) for additional floor kit mounting information.

Use a hoist to move the cabinet into position.

Note: if the cabinet location does not provide access to the cabinet sides, be sure the side panels are mounted before positioning the cabinet.

Install and tighten the mounting bolts.

M3R-32W wall mount, back view

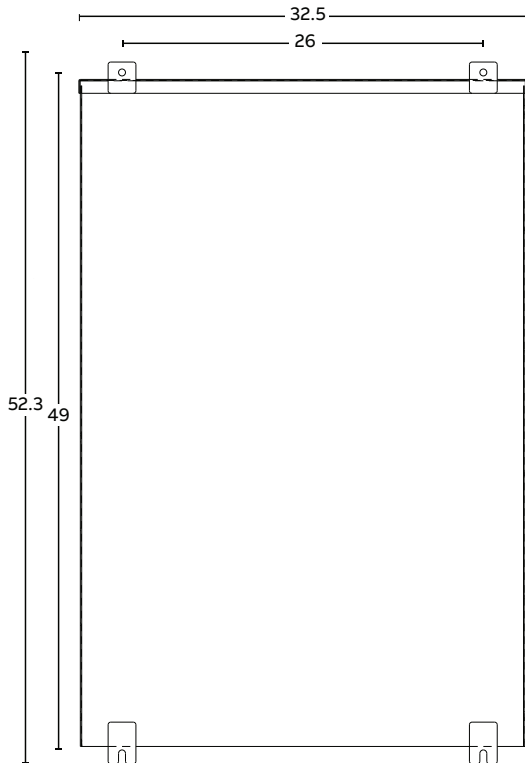

M3R-40W wall mount, back view

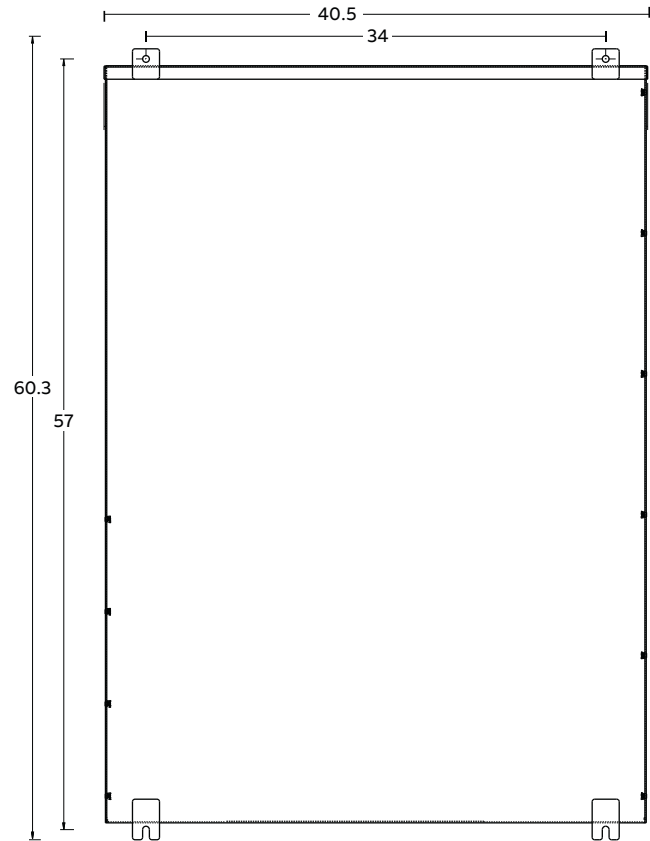

## ■ Installing the wiring



### WARNING

- Metal shavings or debris in the enclosure can damage electrical equipment and create a hazardous condition. Where parts, such as conduit plates require cutting or drilling, first remove the part. If that is not practical, cover nearby electrical components to protect them from all shavings or debris.
- Do not connect or disconnect input or output power wiring, or control wires, when power is applied.
- Never connect line voltage to drive output Terminals T1, T2, and T3.
- Do not make any voltage tolerance tests (Hi Pot or Megger) on any part of the unit. Disconnect motor wires before taking any measurements in the motor or motor wires.
- Make sure that power factor correction capacitors are not connected between the drive and the motor.

## ■ Connection diagrams

ACQ580-xP...+C192+F289 UL Type 3R units are configured for wiring access from the bottom only. The following figures show the layout. For drive control wiring see the Connecting the control cables section of the Electrical installation – North America chapter in the ACQ580-01 Hardware Manual ([3AXD50000044862](#)) or ACQ580-31 Hardware Manual ([3AXD50000045935](#)). Maintain appropriate separation of control and power wires.

**M3R-32W**

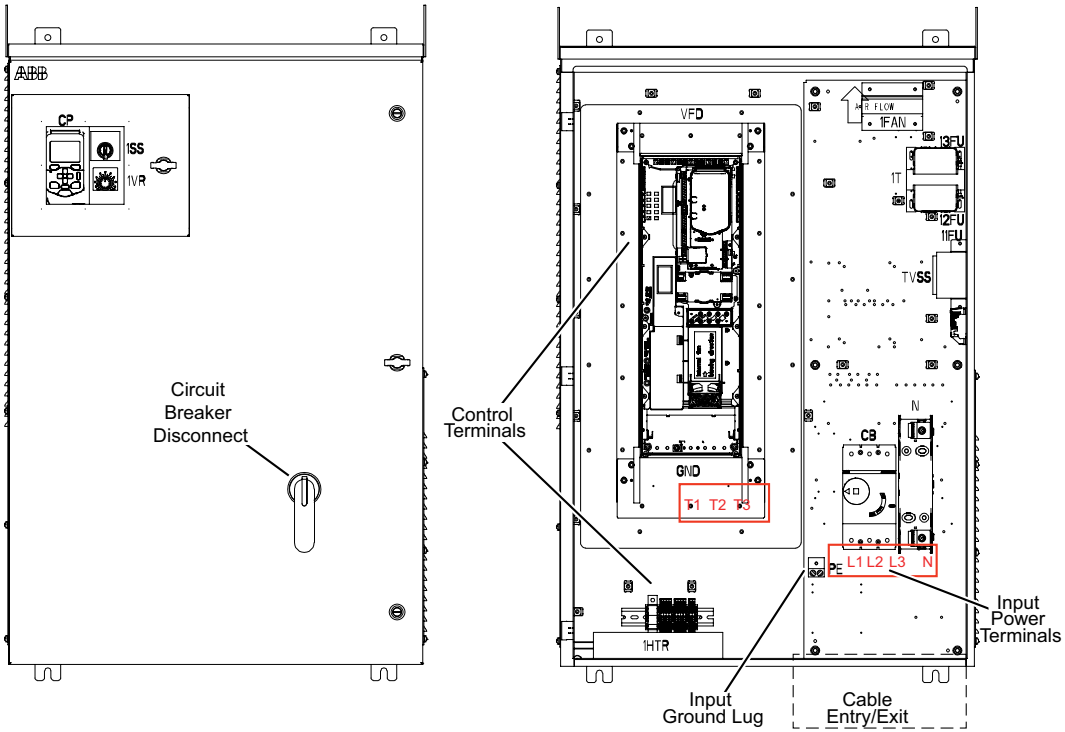

Figure 1. Example shown is ACQ580-0P-096A-4+C192+F289 (R5 frame) with optional hand-off-auto switch (+G302) and speed potentiometer (+G303).

**M3R-40W**

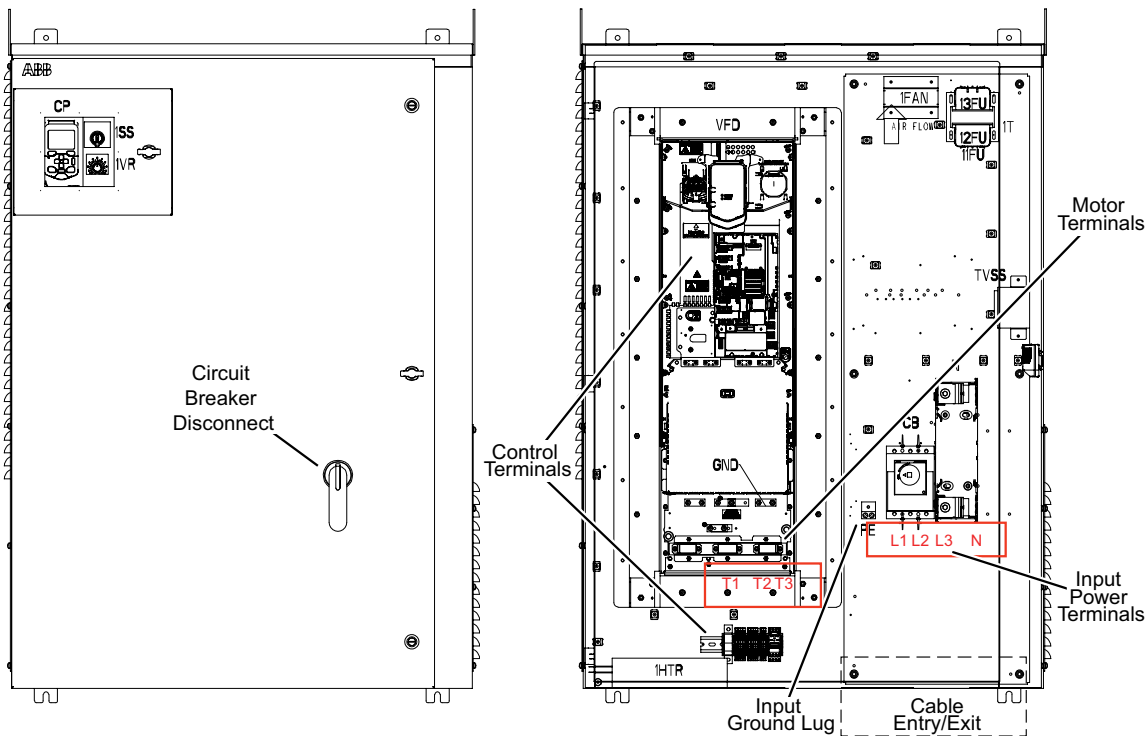

Figure 2. Example shown is ACQ580-3P-180A-4+C192+F289 (R8 frame) with optional hand-off-auto switch (+G302) and speed potentiometer (+G303).

## ■ Power connection terminals

The following table shows the maximum wire size and required tightening torque for incoming power, grounding and motor terminals.

Table 2. Terminal connection table

Type Code	Output Ratings		Base Drive Frame	Enclosure Designation	Terminal Wire Range & Tightening Torque					
					Input/Circuit Breaker Terminals		Motor Terminals		Ground Lugs	
	Amps	HP			Range	Nm	Range	Nm	Maximum	Nm
<b>6-Pulse; 208/240 Volt Ratings</b>										
ACQ580-0P-075A-2+C192+F289	74.8	25	R4	M3R-32W	14 AWG to 1/0 AWG	2.5 Nm	10 AWG to 2/0 AWG	5.5 Nm	2 AWG	1.5 Nm
ACQ580-0P-088A-2+C192+F289	88	30	R5	M3R-32W	4AWG to 300 MCM	25 Nm	4 AWG to 300 MCM	30 Nm	2 AWG	2.2 Nm
ACQ580-0P-114A-2+C192+F289	114	40	R5	M3R-32W	4AWG to 300 MCM	25 Nm	4 AWG to 300 MCM	30 Nm	2 AWG	2.2 Nm
ACQ580-0P-143A-2+C192+F289	143	50	R6	M3R-40W	4AWG to 300 MCM	25 Nm	4 AWG to 300 MCM	30 Nm	350 MCM	9.8 Nm
ACQ580-0P-169A-2+C192+F289	169	60	R7	M3R-40W	0 AWG to 500 MCM	31 Nm	3/0 AWG to 500 MCM	40 Nm	350 MCM	9.8 Nm
ACQ580-0P-211A-2+C192+F289	211	75	R7	M3R-40W	0 AWG to 500 MCM	31 Nm	3/0 AWG to 500 MCM	40 Nm	350 MCM	9.8 Nm
ACQ580-0P-273A-2+C192+F289	248	100	R8	M3R-40W	0 AWG to 500 MCM	31 Nm	2 x 1/0 AWG to 2 x 300 MCM	40 Nm	2 x 350 MCM	9.8 Nm
<b>6-Pulse; 480 Volt Ratings</b>										
ACQ580-0P-052A-4+C192+F289	52	40	R4	M3R-32W	14 AWG to 1/0 AWG	2.5 Nm	10 AWG to 2/0 AWG	5.5 Nm	2 AWG	1.5 Nm
ACQ580-0P-065A-4+C192+F289	65	50	R4	M3R-32W	14 AWG to 1/0 AWG	2.5 Nm	10 AWG to 2/0 AWG	5.5 Nm	2 AWG	1.5 Nm
ACQ580-0P-077A-4+C192+F289	77	60	R4	M3R-32W	14 AWG to 1/0 AWG	2.5 Nm	10 AWG to 2/0 AWG	5.5 Nm	2 AWG	1.5 Nm
ACQ580-0P-096A-4+C192+F289	96	75	R5	M3R-32W	4AWG to 300 MCM	25 Nm	4 AWG to 300 MCM	30 Nm	2 AWG	2.2 Nm
ACQ580-0P-124A-4+C192+F289	124	100	R6	M3R-40W	4AWG to 300 MCM	25 Nm	4 AWG to 300 MCM	30 Nm	350 MCM	9.8 Nm
ACQ580-0P-156A-4+C192+F289	156	125	R7	M3R-40W	4AWG to 300 MCM	25 Nm	4 AWG to 300 MCM	30 Nm	350 MCM	9.8 Nm
ACQ580-0P-180A-4+C192+F289	180	150	R7	M3R-40W	4AWG to 300 MCM	25 Nm	4 AWG to 300 MCM	30 Nm	350 MCM	9.8 Nm
ACQ580-0P-240A-4+C192+F289	240	200	R8	M3R-40W	0 AWG to 500 MCM	31 Nm	2 x 1/0 AWG to 2 x 300 MCM	40 Nm	2 x 350 MCM	9.8 Nm
<b>ULH; 480 Volt Ratings</b>										
ACQ580-3P-052A-4+C192+F289	52	40	R6	M3R-40W	14 AWG to 1/0 AWG	2.5 Nm	10 AWG to 2/0 AWG	5.5 Nm	2 AWG	2.9 Nm
ACQ580-3P-065A-4+C192+F289	65	50	R6	M3R-40W	14 AWG to 1/0 AWG	2.5 Nm	10 AWG to 2/0 AWG	5.5 Nm	2 AWG	2.9 Nm
ACQ580-3P-077A-4+C192+F289	77	60	R6	M3R-40W	14 AWG to 1/0 AWG	2.5 Nm	10 AWG to 2/0 AWG	5.5 Nm	2 AWG	2.9 Nm
ACQ580-3P-096A-4+C192+F289	96	75	R8	M3R-40W	4AWG to 300 MCM	25 Nm	4 AWG to 300 MCM	30 Nm	350 MCM	9.8 Nm
ACQ580-3P-124A-4+C192+F289	124	100	R8	M3R-40W	4AWG to 300 MCM	25 Nm	4 AWG to 300 MCM	30 Nm	350 MCM	9.8 Nm
ACQ580-3P-156A-4+C192+F289	156	125	R8	M3R-40W	4AWG to 300 MCM	25 Nm	4 AWG to 300 MCM	30 Nm	350 MCM	9.8 Nm
ACQ580-3P-180A-4+C192+F289	180	150	R8	M3R-40W	4AWG to 300 MCM	25 Nm	4 AWG to 300 MCM	30 Nm	350 MCM	9.8 Nm

## ■ Branch circuit protection

Input power is connected to the ACQ580 irrigation drive package through a door interlocked circuit breaker. When connected to a 240V or 480V power source, the ACQ580 with circuit breaker is suitable for use on a circuit capable of delivering not more than 65,000 RMS symmetrical amperes. Additional fuse protection is not required by UL when using circuit breakers as supplied.

## Operation

The ACQ580 irrigation drive package uses irrigation specific software that is based on the ACQ580 pump control firmware. The information below details items that are unique to the ACQ580 irrigation drive package. See the ACQ580 pump control program firmware manual ([3AXD50000035867](#)) for additional information on ACQ580 software and parameters.

■ **Irrigation specific home screens**

Three home screen options that been configured specifically for irrigation. The primary home screen includes the exclusive total flow, acre foot calculation.

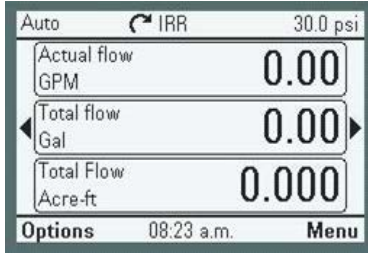

Primary home screen

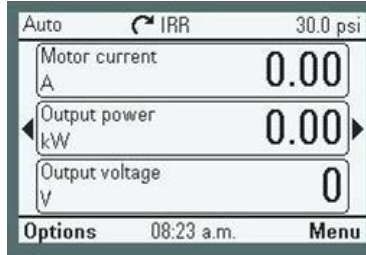

Secondary home screen

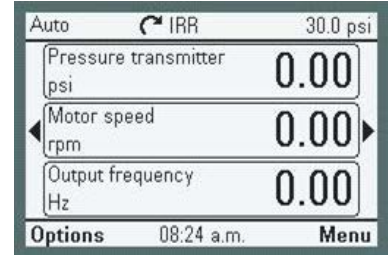















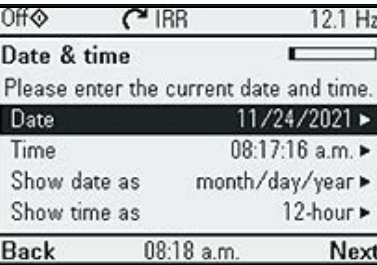









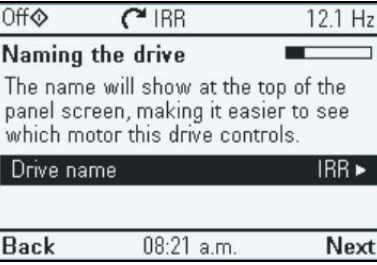

Tertiary home screen

■ **How to start up the drive using First start assistant with the irrigation specific software**

**Note:** Automatic selection of supply voltage is not supported in the ACQ580 ULH irrigation drives (ACQ580-3P). You must select the supply voltage manually using parameter 95.01 Supply Voltage. Follow the instructions below.



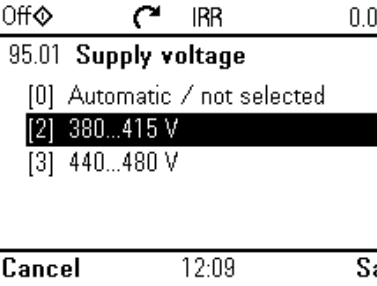











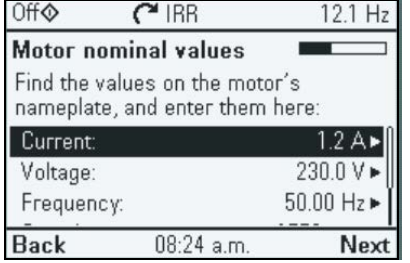



<b>Safety</b>	
	Do not start-up the drive unless you are a qualified electrician. Read and obey the instructions in chapter <i>Safety instructions</i> at the beginning of the <i>Hardware manual</i> of the drive. Ignoring the instructions can cause physical injury or death, or damage to the equipment.
<input type="checkbox"/>	Check the installation. See chapter <i>Installation checklist</i> in the <i>Hardware manual</i> of the drive.
<input type="checkbox"/>	Make sure there is no active start on (DI1 in factory settings, that is, default configuration). The drive will start up automatically at power-up if the external run command is on and drive is in the external control mode.  Check that the starting of the motor does not cause any danger.  <b>De-couple the driven machine</b> if: <ul style="list-style-type: none"> <li>• there is a risk of damage in case of an incorrect direction of rotation, or</li> <li>• a <b>Normal</b> ID run is required during the drive start-up, when the load torque is higher than 20% or the machinery is not able to withstand the nominal torque transient during the ID run.</li> </ul>
<b>Hints on using the assistant control panel</b>	
<p>The two commands at the bottom of the display (<b>Options</b> and <b>Menu</b> in the figure on the right), show the functions of the two softkeys  and  located below the display.</p> <p>The commands assigned to the softkeys vary depending on the context.</p> <p>Use keys  ,  ,  and  to move the cursor and/or change values depending on the active view.</p> <p>Key  shows a context-sensitive help page. For more information, see <i>ACx-AP-x assistant control panels user's manual</i> (<a href="#">3AXD50000035867</a>)</p>	

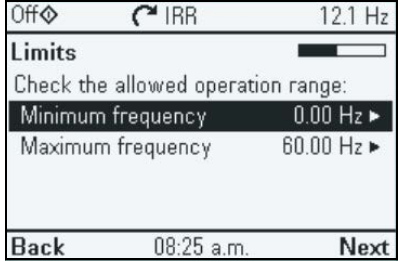



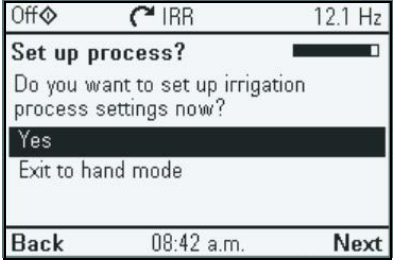

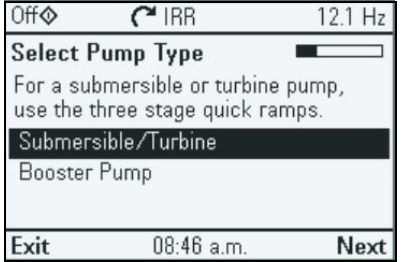





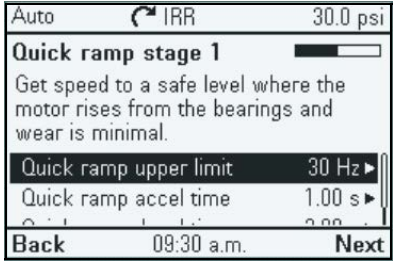

<b>1 – First start assistant guided settings: Language, date and time, and motor nominal values</b>	
<input type="checkbox"/> Have the motor or pump name plate data at hand.  Power up the drive.	
<input type="checkbox"/> The First start assistant guides you through the first start-up.  The assistant begins automatically. Wait until the control panel enters the view shown on the right.  Select the language you want to use by highlighting it (if not already highlighted) and pressing  ( <b>OK</b> ).	 <p>English Deutsch Suomi Français Italiano Nederlands Svenska</p> <p style="text-align: right;">OK ▶</p>
<input type="checkbox"/> Set the date and time as well as date and time display formats. <ul style="list-style-type: none"> <li>Go to the edit view of a selected row by pressing .</li> <li>Scroll the view with  and .</li> </ul> Go to the next view by pressing  ( <b>Next</b> ).	 <p>Off ◊ IRR 12.1 Hz</p> <p><b>Date &amp; time</b></p> <p>Please enter the current date and time.</p> <p>Date 11/24/2021 ▶</p> <p>Time 08:17:16 a.m. ▶</p> <p>Show date as month/day/year ▶</p> <p>Show time as 12-hour ▶</p> <p>Back 08:18 a.m. Next</p>
<input type="checkbox"/> To change a value in an edit view: <ul style="list-style-type: none"> <li>Use  and  to move the cursor left and right.</li> <li>Use  and  to change the value.</li> <li>Press  (<b>Save</b>) to accept the new setting, or press  (<b>Cancel</b>) to go back to the previous view without making changes.</li> </ul>	 <p>Off ◊ IRR 12.1 Hz</p> <p><b>Date</b></p> <p>Month Day Year</p> <p><b>11/24/2021</b></p> <p>Wednesday</p> <p>Cancel 08:20 a.m. Save</p>
<input type="checkbox"/> To give the drive a name that will be shown at the top, press  . If you do not want to change the default name (IRR), continue by pressing  ( <b>Next</b> ).  Hint: Name the drive, for example, Pump 1.	 <p>Off ◊ IRR 12.1 Hz</p> <p><b>Naming the drive</b></p> <p>The name will show at the top of the panel screen, making it easier to see which motor this drive controls.</p> <p>Drive name IRR ▶</p> <p>Back 08:21 a.m. Next</p>
<input type="checkbox"/> <b>ACQ580 ULH Irrigation drives:</b> Select the supply voltage with parameter 95.01 Supply voltage: <ul style="list-style-type: none"> <li>In the First start assistant menu, select Exit and press  (<b>Next</b>).</li> <li>In the Home view, press  (<b>Menu</b>) to enter the Main menu.</li> <li>In the Main menu, go to <b>Parameters &gt; Complete list &gt; 95 HW configuration</b> by selecting the correct row and pressing  (<b>Select</b>) repeatedly.</li> <li>Select parameter 95.01 Supply voltage and press  (<b>Edit</b>).</li> <li>Select supply voltage <b>380...415</b> or <b>440...480</b> using keys  and . Press  (<b>Save</b>).</li> <li>Go back to the Main menu by pressing  (<b>Back</b>) repeatedly.</li> <li>In the Main menu, select <b>First start assistant</b> and press  (<b>Select</b>) to enter the First start assistant menu.</li> </ul> Continue with the following steps for commissioning the ACQ580.	 <p>Off ◊ IRR 0.0 Hz</p> <p>95.01 <b>Supply voltage</b></p> <p>[0] Automatic / not selected</p> <p><b>[2] 380...415 V</b></p> <p>[3] 440...480 V</p> <p>Cancel 12:09 Save</p>

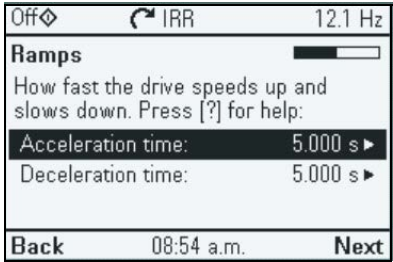
Refer to the motor or pump nameplate for the following nominal value settings of the motor.  
Enter the values exactly as shown on the motor or pump nameplate.

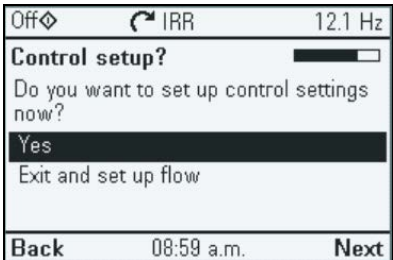
Example of a nameplate of an induction (asynchronous) motor:

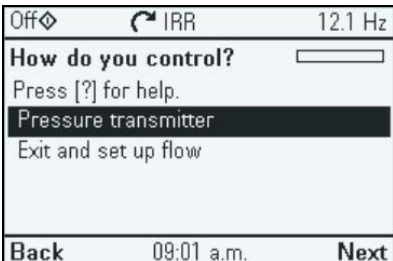
ABB Motors							
3 ~ motor		M2AA 200 MLA 4					
		IEC 200 M/L 55					
		No					
		Ins. cl. F			IP 55		
V	Hz	kW	r/min	A	cos φ	IA/IN	tE/S
690 Y	50	30	1475	32.5	0.83		
400 D	50	30	1475	56	0.83		
660 Y	50	30	1470	34	0.83		
380 D	50	30	1470	59	0.83		
415 D	50	30	1475	54	0.83		
440 D	60	35	1770	59	0.83		
Cat. no		3GAA 202 001 - ADA					
6312/C3		6210/C3		180 kg			
IEC 34-1							

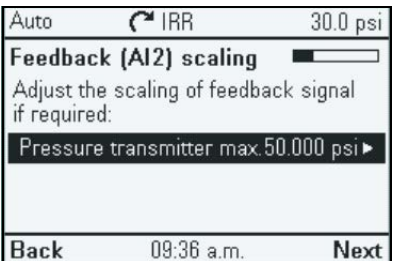
<input type="checkbox"/>	<p>Check that the motor data is correct. Values are predefined on the basis of the drive size but you should verify that they correspond to the motor.</p> <p>Go to the edit view of a selected row by pressing .</p> <ul style="list-style-type: none"> <li>• Scroll the view with  and .</li> </ul> <p>Press  (<b>Next</b>) to continue.</p>	 <p>Off  12.1 Hz</p> <p><b>Motor nominal values</b></p> <p>Find the values on the motor's nameplate, and enter them here:</p> <p>Current: 1.2 A ▶</p> <p>Voltage: 230.0 V ▶</p> <p>Frequency: 50.00 Hz ▶</p> <p>Back 08:24 a.m. Next</p>
<input type="checkbox"/>	<p>Adjust the limits according to your needs.</p> <ul style="list-style-type: none"> <li>• Go to the edit view of a selected row by pressing .</li> <li>• Scroll the view with  and .</li> </ul> <p>Go to the next view by pressing  (<b>Next</b>).</p>	 <p>Off  12.1 Hz</p> <p><b>Limits</b></p> <p>Check the allowed operation range:</p> <p>Minimum frequency 0.00 Hz ▶</p> <p>Maximum frequency 60.00 Hz ▶</p> <p>Back 08:25 a.m. Next</p>
<input type="checkbox"/>	<p>If you want to set up irrigation process settings, select Yes and press  (<b>Next</b>).</p> <p>If you do not want to set up irrigation process settings, select Exit to hand mode and press  (<b>Next</b>).</p>	 <p>Off  12.1 Hz</p> <p><b>Set up process?</b></p> <p>Do you want to set up irrigation process settings now?</p> <p>Yes</p> <p>Exit to hand mode</p> <p>Back 08:42 a.m. Next</p>
<input type="checkbox"/>	<p>Select pump type; <b>Submersible/Turbine</b> or <b>Boost Pump</b> and press  (<b>Next</b>).</p>	 <p>Off  12.1 Hz</p> <p><b>Select Pump Type</b></p> <p>For a submersible or turbine pump, use the three stage quick ramps.</p> <p>Submersible/Turbine</p> <p>Booster Pump</p> <p>Exit 08:46 a.m. Next</p>

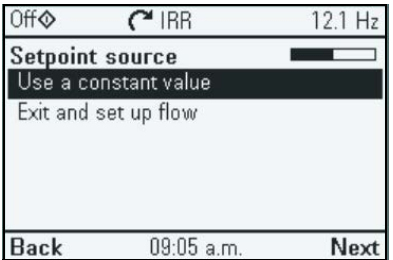
<input type="checkbox"/>	<p>If the pump type of Submersible/Turbine was selected, adjust the quick ramp settings for seconds and Hz by pressing .</p> <ul style="list-style-type: none"> <li>• Scroll the view with  and .</li> </ul> <p>Press  (<b>Next</b>) to continue.</p>	
<input type="checkbox"/>	<p>If the pump type of Booster Pump was selected, adjust the ramp acceleration and deceleration times .</p> <p>Press  (<b>Next</b>) to continue.</p>	
<input type="checkbox"/>	<p>If you want to set up control settings, select Yes and press  (<b>Next</b>).</p> <p>If you do not want to set up control settings, select Exit and set up flow and press  (<b>Next</b>).</p>	
<input type="checkbox"/>	<p>If you want to control via a pressure transmitter, select <b>Pressure transmitter</b> and press  (<b>Next</b>).</p> <p>If you do not want to control via a pressure transmitter, select <b>Exit and set up flow</b> and press  (<b>Next</b>).</p>	
<input type="checkbox"/>	<p>Adjust the scaling of feedback to your needs.</p> <ul style="list-style-type: none"> <li>• Go to the edit view of a selected item by pressing .</li> </ul> <p>Press  (<b>Next</b>) to continue.</p>	
<input type="checkbox"/>	<p>If you want to use a constant value for your pressure transmitter, select <b>Use a constant value</b> and press  (<b>Next</b>).</p> <p>If you do not want to use a constant value, select <b>Exit and set up flow</b> and press  (<b>Next</b>).</p>	

<input type="checkbox"/>	<p>Adjust the setpoint to your needs.</p> <ul style="list-style-type: none"> <li>Go to the edit view of a selected item by pressing </li> </ul> <p>Press  (<b>Next</b>) to continue.</p>	
<input type="checkbox"/>	<p>If you want to set up flow calculations, select <b>Yes</b> and press  (<b>Next</b>).</p> <p>If you do not want to set up flow calculations, select <b>Exit to hand mode</b> and press  (<b>Next</b>).</p>	
<input type="checkbox"/>	<p>Adjust flow calculations to your needs.</p> <ul style="list-style-type: none"> <li>Go to the edit view of a selected item by pressing  or by pressing  (<b>Edit</b>).</li> <li>Scroll the view with  and .</li> </ul> <p>Press  (<b>Done</b>) to complete first start assistant set up.</p>	
<input type="checkbox"/>	<p>The Home view 1 monitoring the values of the selected signals is shown on the panel.</p> <p>There are three preconfigured Home view displays. Home view 1 is default Home view. You can browse them with keys  and .</p>	
<p><b>2 – Additional settings in the Primary settings menu</b></p>		
<input type="checkbox"/>	<p>Make any additional adjustments, for example, pump protections, starting from the <b>Main</b> menu – press  (<b>Menu</b>) to enter the <b>Main</b> menu.</p> <p>Select <b>Primary settings</b> and press  (<b>Select</b>) (or ).</p> <p>In the <b>Primary settings</b> menu, select <b>Pump protections</b> and press  (<b>Select</b>) (or ).</p> <p>To get more information on the <b>Primary settings</b> menu items, press  to open the help page.</p>	

### 3 – Hand/Off/Auto operation



The drive can be in remote control or local control, and in local control there are additionally two different modes.

Remote control: Drive is controlled from the I/O or the fieldbus.

- Top row of the view shows Auto.

Local control: Drive is controlled from the control panel.

- Top row of the view shows Off, that is, the drive is in the Off mode. Drive is stopped.
- Top row of the view shows Hand, that is, the drive is in the Hand mode. Drive is running. The initial reference in the Hand mode is copied from the drive reference.  
Symbol  $\blacklozenge$  on the top row indicates that you can change the reference with  $\blacktriangle$  and  $\blacktriangledown$ .

The following diagram shows the state transitions when you press the Hand, Off or Auto button:

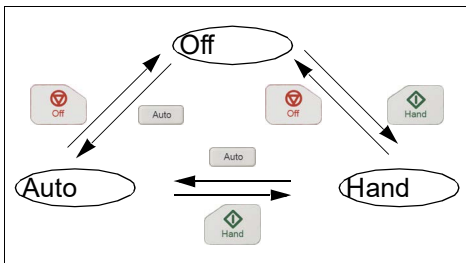

**Note:** When you restart the drive while fault 7081 Control panel loss is active, the mode changes from Hand or Off to Auto.

Auto	$\blacklozenge$	IRR	30.0 Hz
Output frequency	Hz	30.00	
Motor current	A	0.46	
Motor torque	%	8.9	
		12:30	Menu
Off	$\blacklozenge$	IRR	0.0 Hz
Output frequency	Hz	0.00	
Motor current	A	0.00	
Motor torque	%	0.0	
		12:37	Menu
Hand	$\blacklozenge$	IRR	$\blacktriangle$ 30.0 Hz
Output frequency	Hz	30.00	
Motor current	A	0.46	
Motor torque	%	8.8	
Reference		12:38	Menu
Off	$\blacklozenge$	IRR	0.0 Hz
<div style="display: flex; align-items: center;"> <div style="font-size: 2em; margin-right: 10px;">✘</div> <div> <h2 style="margin: 0;">Fault 7081</h2> <p style="margin: 0;">Aux code: 0000 0000</p> <p style="margin: 0;"><b>Control panel loss</b> 12:41:43</p> <p style="margin: 0;">Control panel loss fault</p> </div> </div>			
Hide		12:42	Reset

#### ■ Irrigation primary settings

The ACQ580 irrigation drive software contains a Primary Settings menu that allows you to adjust and define additional settings in the drive.

The Primary Settings and sub-settings in the ACQ580 irrigation drive are:

- Start, stop reference
  - Basic operation setup
  - Basic control setup
  - Auto control selection
  - Secondary auto control location
  - Interlocks/permissives
  - Stop mode
  - Constant frequencies
  - Start mode
  - Start delay
- Pump features
  - Flow protection
  - Pressure protection
  - Dry pump protection
  - Flow calculation
  - Soft pipe fill
- Motor
  - Nominal values
  - Start mode
  - Phase order
  - Switching frequency
  - Thermal protection estimated
  - Thermal protection measured
  - Stall protection

- Ramps
  - Quick ramps
  - Acceleration time
  - Deceleration time
  - Stop mode
  - Ramp time target frequency
- Limits
  - Minimum frequency
  - Maximum frequency
  - Maximum current
- PID Control
  - PID assistant
  - Activate PID control
  - Start/stop from
  - Unit
  - PID status
  - Feedback
  - Setpoint
  - Tuning
  - Increase output: Feedback
  - Output
  - Sleep function
- Fieldbus
  - Embedded fieldbus
  - Fieldbus adapter
- Fault functions
  - Auto-reset faults
  - Additional fault reset
  - Enable AI2 low detection
- Advanced functions
  - External events
  - Supervision
  - Timed functions
  - Confirmation for HAND/OFF
- Clock, region, display
  - Select drive
  - Language
  - Date & time
  - Units
  - Drive name
  - Contact info in fault view
  - Edit texts
  - Display settings
  - Show in lists
  - Edit Home view
  - Show inhibit pop-up
- Assistants
  - Irrigation Smart Assist
  - Basic operation setup
  - Basic control setup
  - Nominal values
  - ID run
  - PID assistants
  - Security
  - Control mode

**Note:** The Primary Settings menu enables you to program the majority of the drive functionality or features; more advanced configuration can be done via the parameters. For more information on the different parameters, see the Parameters chapter of the ACQ580 pump control program firmware manual ([3AXD5000035867](#)).

#### ■ Irrigation total flow accumulated feature

The ACQ580 irrigation drive includes a total flow accumulated feature and the exclusive total flow, acre foot calculation. These features were developed specifically to meet the irrigation market's needs.

The parameters associated with these features are:

- P47.01 - Total flow - acre ft.
    - Total accumulated flow in unit acre ft
    - 1 acre ft. = 325,851.427 gallons
    - Parameter type is Real 32
    - Max value = 2,147,483.000
  - P47.11 - Total flow days
    - Total number of days flow is accumulated before value is reset
    - Set value to zero (0) and set P47.12 to zero (0) to disable total flow reset function
  - P47.12 - Total flow elapsed
    - Number of days elapsed in “total flow days” time period
-

■ Default I/O connection diagrams

I/O connection diagram

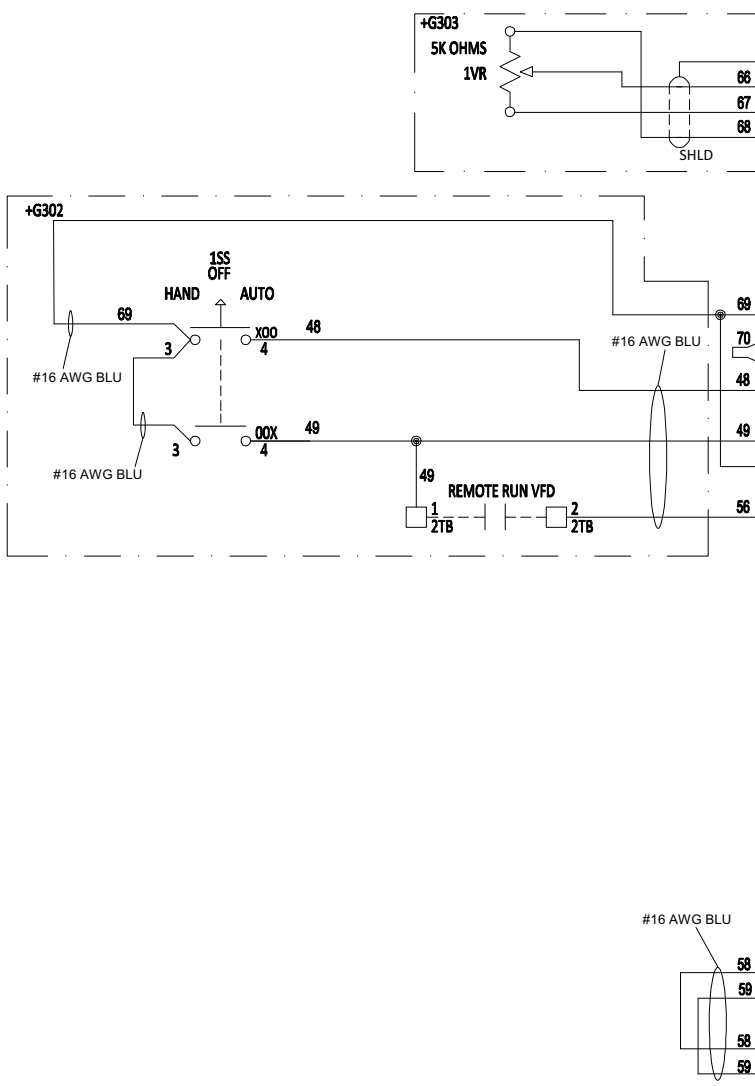

VFD		ACQ580
<b>X1 REFERENCE VOLTAGE AND ANALOG I/O</b>		
1	SCR	SIGNAL CABLE SHIELD (SCREEN)
2	A11	OUTPUT FREQUENCY/SPEED REF 0-10 V, HAND
3	AGND	ANALOG INPUT CIRCUIT COMMON
4	+10V	REFERENCE VOLTAGE 10 VDC
5	A12	<b>OUTPUT FREQUENCY/SPEED REF 4-20mA, AUTO</b>
6	AGND	ANALOG INPUT CIRCUIT COMMON
7	A01	OUTPUT FREQUENCY 0-20mA
8	A02	MOTOR CURRENT 0-20 mA
9	AGND	ANALOG OUTPUT CIRCUIT COMMON
<b>X2 AND X3 AUX VOLTAGE OUTPUT / PROGRAMMABLE DIGITAL INPUTS</b>		
10	+24V	AUX VOLTAGE OUTPUT +24 VDC 250 mA MAX
11	DGND	AUX VOLTAGE OUTPUT COMMON
12	DCOM	DIGITAL INPUT COMMON FOR ALL
13	DI1	START (1) / STOP (0) - HAND
14	DI2	FORWARD (0) / REVERSE (1) HAND
15	DI3	HAND (0) / AUTO (1)
16	DI4	RUN ENABLE
17	DI5	FORWARD (0) / REVERSE (1) AUTO
18	DI6	STOP (0) / START (1) - AUTO
<b>X6, X7, AND X8 RELAY OUTPUTS</b>		
19	R01C	READY RUN 250VAC / 30VDC 2A
20	R01A	
21	R01B	
22	R02C	RUNNING 250VAC / 30VDC 2A
23	R02A	
24	R02B	
25	R03C	FAULT (-1) 250VAC / 30VDC 2A
26	R03A	
27	R03B	
<b>X5 EMBEDDED FIELDBUS</b>		
29	B+	EMBEDDED FIELDBUS EFB (EIA-485)
30	A-	
31	DGND	
S4	TERM	TERMINATION SWITCH
S5	BIAS	BIAS RESISTORS SWITCH
<b>X4 SAFE TORQUE OFF</b>		
34	OUT1	SAFE TORQUE OFF. FACTORY CONNECTION.
35	OUT2	
36	SGND	BOTH CIRCUITS MUST BE CLOSED FOR THE DRIVE TO START.
37	IN1	
38	IN2	
<b>X10 24V AC / DC</b>		
40	24VAC/DC+ IN	EXTERNAL 24V AC/DC INPUT TO POWER THE CONTROL UNIT WHEN THE MAIN SUPPLY IS DISCONNECTED.
41	24VAC/DC- IN	

NOTE: TERMINALS 40 AND 41 AVAILABLE ON R6 AND LARGER ONLY.

**Note:** Dashed line portions indicate optional hand-off-auto switch (G302) and speed potentiometer (G303)

The ACQ580 irrigation drive package is factory programmed in the following parameters:

Parameter	Parameter name	Value
12.25	AI2 unit selection	mA
19.11	Ext1/Ext2 selection	DI3
20.01	Ext1 commands	In1 Start, In2 Dir
20.04	Ext1 in2 source	DI2
20.06	Ext2 commands	In1 Start, In2 Dir
20.08	Ext2 in 1 source	DI6
20.09	Ext2 in 2 source	DI5
20.21	Direction	Request
20.41	Start interlock 1	DI4
21.03	Stop mode	Coast
28.11	Ext1 frequency ref1	AI1 scaled default (if +G303 speed pot. is included) OR Control panel; ref saved (if <u>no</u> +G303 speed pot. is included)
28.15	Ext2 frequency ref1	AI2 scaled
28.22	Constant frequency sel1	Always off

### Optional floor kit mounting

Optional floor/ground mounting kits are available for purchase. Assembly instructions for the floor kits are shipped with each kit and should be used for installation. Abbreviated versions of the instructions can also be found as a reference below.



**WARNING!** Before you begin read [Safety instructions on Page 2](#).



**WARNING!** When the ACQ580 irrigation drive package is connected to the line power, the Motor Terminals T1, T2, and T3 are live even if the motor is not running. Do not make any connections when the ACQ580 irrigation drive package is connected to the line. Disconnect and lock out power to the drive before servicing the drive. Failure to disconnect power may cause serious injury or death.

---

■ Floor kit identification

Table 3. ACQ580-xP+C192 floor kits

Frame	Light Duty HP	Enclosure Designation	Floor Kit
<b>6-Pulse; 208/240 Volt Ratings</b>			
R4	20	M3R-32W	Floor-Kit-3R-Irrigation-12Hx18D (3AUA0000163767)
R5	30-40		
R6	50	M3R-40W	Floor-Kit-3R-Irrigation-12Hx24D (3AUA0000235652)
R7	60-75		
R8	100		
<b>6-Pulse; 480 Volt Ratings</b>			
R4	40-60	M3R-32W	Floor-Kit-3R-Irrigation-12Hx18D (3AUA0000163767)
R5	75		
R6	100	M3R-40W	Floor-Kit-3R-Irrigation-12Hx24D (3AUA0000235652)
R7	125-150		
R8	200		
<b>ULH; 480 Volt Ratings</b>			
R6	40-60	M3R-40W	Floor-Kit-3R-Irrigation-12Hx24D (3AUA0000235652)
R8	75-150		

**Enclosure M3R-32W; Floor-Kit-3R-Irrigation-12Hx18D**

**Step 1:** Prepare ground mounting surface for enclosure.

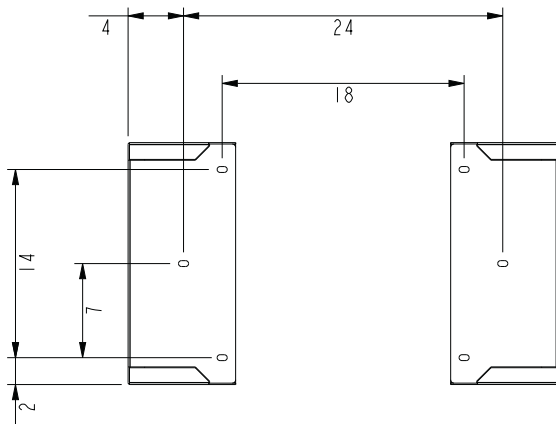

**Step 2:** Using a lifting device, carefully lay the enclosure on its back. Drill ten (10) holes with 7/16" drill bit.

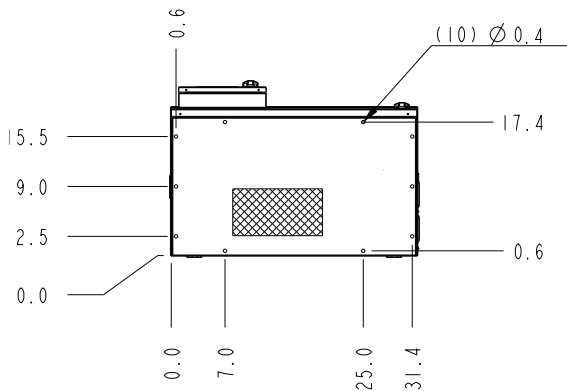

**Step 3:** Remove vent plate on the right and left sides of the enclosure to access the inside of the unit for hardware assembly. The plates may be remounted using two screws for safe keeping.

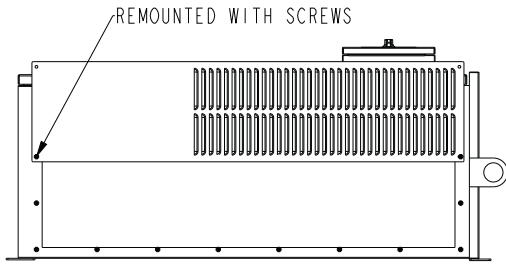

**Step 4:** Assemble feet with mounting hardware.

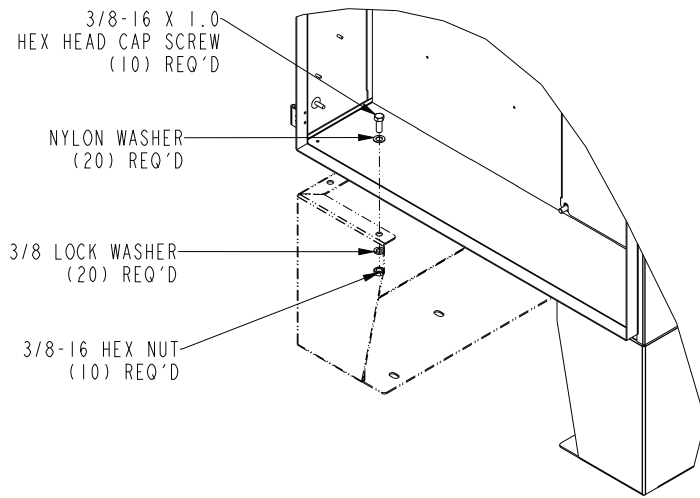

**Step 5:** Using the lifting eyes, lift the enclosure and place onto mounting studs, then assemble hardware.

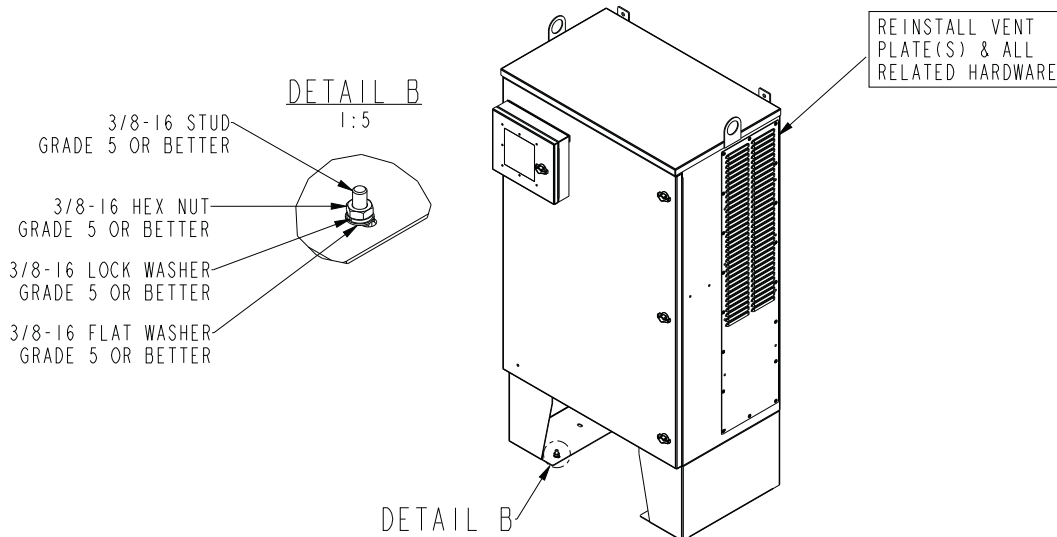

**Enclosure M3R-40W; Floor-Kit-3R-Irrigation-12Hx24D**

**Step 1:** Prepare ground mounting surface for enclosure.

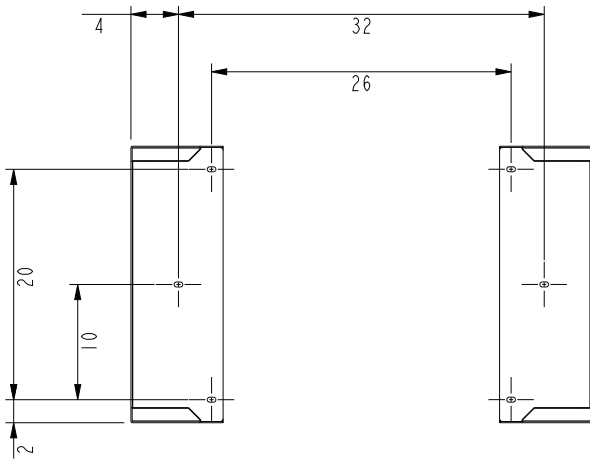

**Step 2:** Using a lifting device, carefully lay the enclosure on its back. Drill ten (10) holes with 7/16" drill bit.

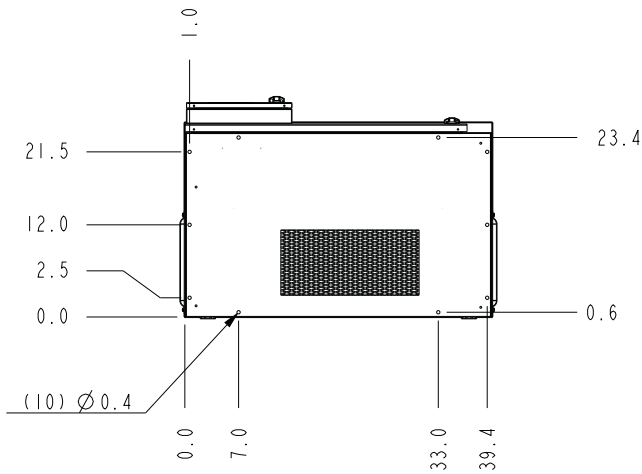

**Step 3:** Remove vent plate on the right and left sides of the enclosure to access the inside of the unit for hardware assembly. The plates may be removed using two screws for safe keeping.

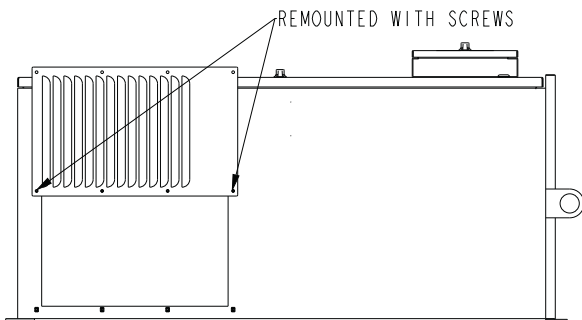

**Step 4: Assemble feet with mounting hardware.**

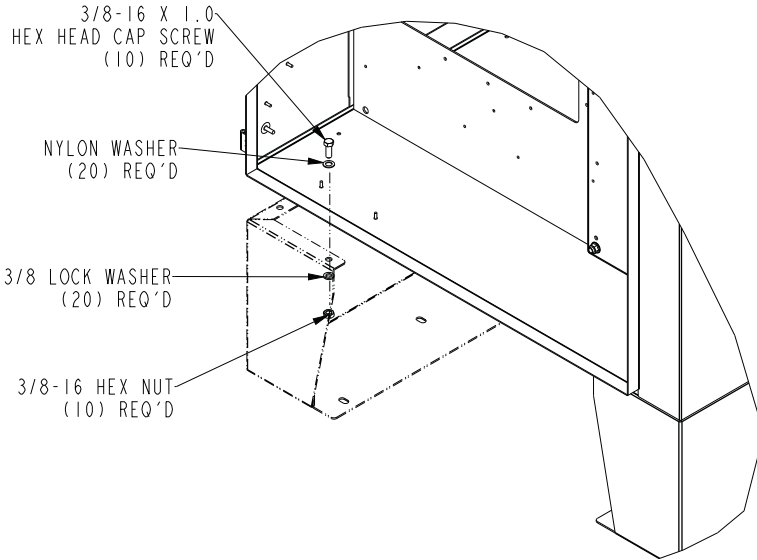

**Step 5: Using the lifting eyes, lift the enclosure and place onto mounting studs, then assemble hardware.**

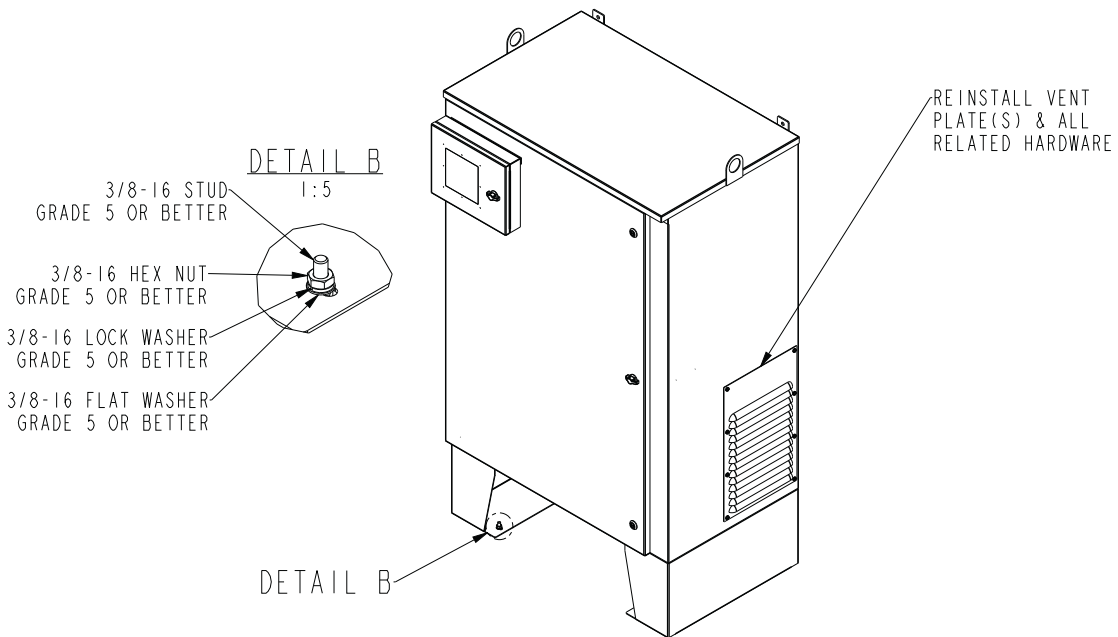

## Dimensions & weights

### M3R-32W

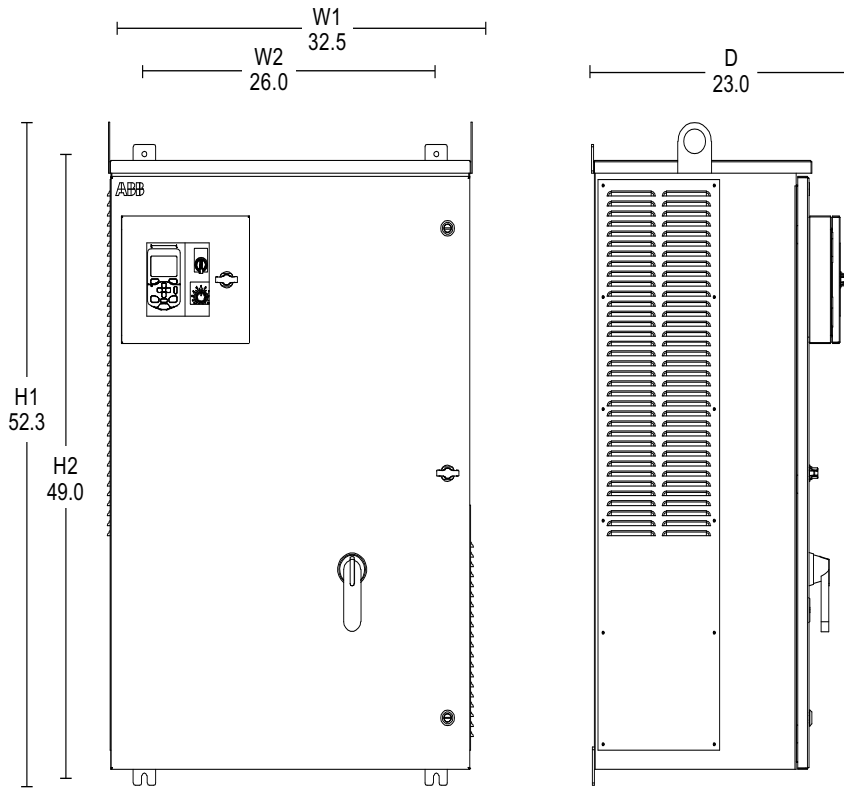

### M3R-40W

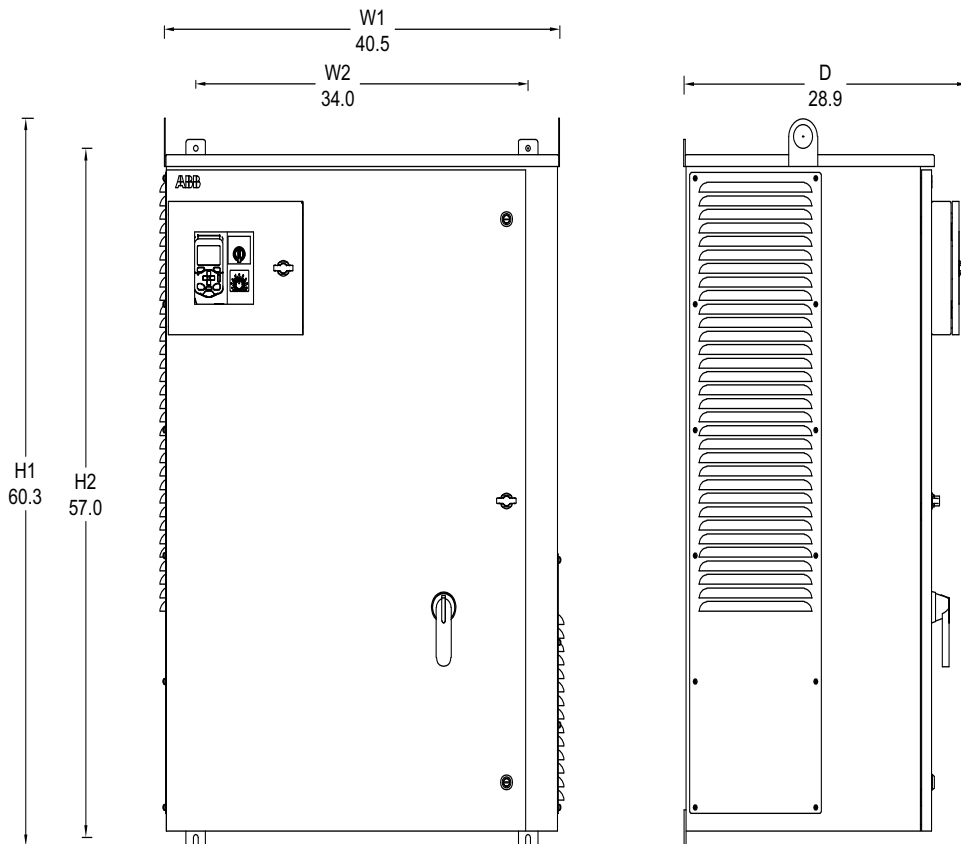

Table 4. Dimensions &amp; Weights

Dim ref	Frame size	Height (H1)	Height (H2)	Width (W1)	Width (W2)	Depth (D)	Weight (6-pulse)	Weight (ULH)
		in	in	in	in	in	lb	lb
M3R-32W	R4	52.30	49.00	32.50	26.00	23.00	252	--
M3R-32W	R5	52.30	49.00	32.50	26.00	23.00	266	--
M3R-40W	R6	60.30	57.00	40.50	34.00	28.90	487	528
M3R-40W	R7	60.30	57.00	40.50	34.00	28.90	513	--
M3R-40W	R8	60.30	57.00	40.50	34.00	28.90	546	640

Notes:

M3R-32W is used for 6-pulse drives with R4 and R5 base drive frame sizes

M3R-40W is used for 6-pulse drives with R6-R8 and R5 base drive frame sizes and all ULH drives

H1 - Height

H2 - Mounting Height

W1 - Width

W2 - Mounting Width

Table 5. Free space requirements

	Above	Below	Right Side	Left Side
	in	in	in	in
All Sizes	12	12	8	8

NOTE: 16 inches of free space is required between heat generating panels/devices

## Ambient conditions

The following table lists the ACQ580 irrigation drive package environmental requirements.

### Ambient environment requirements

	Installation site	Storage and transportation
Altitude	<ul style="list-style-type: none"> <li>0...100m (0...330ft)</li> <li>1000...400m (330...12,120ft) with derating of 1% every 100m (330ft)</li> </ul>	
Ambient temperature	<ul style="list-style-type: none"> <li>-20...+40°C (5...104°F) with heater</li> <li>-20...+50°C (5...122°F) with heater and derate</li> </ul>	<ul style="list-style-type: none"> <li>-40...+70°C (-40...158°F)</li> </ul>
Relative humidity	<ul style="list-style-type: none"> <li>5...95%, no condensation allowed</li> </ul>	

## Applicable standards

Panel compliance with the following standards is identified by the standards “marks” on the panel.

Mark	Applicable standards	
	UL 508A	UL Standard for Safety, Industrial Control Panels
	C22.2 No. 14	CSA Standards for Industrial Control Equipment

Compliance is valid with the following provision:

- The installation rules of this manual are followed

## Maintenance intervals

If installed in an appropriate environment, the ACQ580 irrigation drive package requires very little maintenance.

### ■ Drive module maintenance

For detailed drive module maintenance schedules and information see the Maintenance and hardware diagnostics section of in the ACQ580-01 Hardware Manual ([3AXD50000044862](#)) or ACQ580-31 Hardware Manual ([3AXD50000045935](#)). In general, periodic maintenance is recommended for the following drive module components:

- Heatsinks
- Drive module fans
- Capacitors
- Assistant control panel

### ■ Enclosure fan maintenance

There are two internal stirring fans mounted inside the ACQ580 irrigation drive package, one in the front (clean) section of the enclosure and one in the back (dirty) section of the enclosure. The fans should be replaced after every 60,000 hours of run time.

### ■ Input voltage surge suppressor maintenance

ABB recommends replacing the input voltage surge suppressor (TVSS) installed in the ACQ580 irrigation drive package every three (3) years.

## **Further information**

### Product and service inquiries

Address any inquiries about the product to your local ABB representative, quoting the type designation and serial number of the unit in question. A listing of ABB sales, support and service contacts can be found by navigating to [www.abb.com/searchchannels](http://www.abb.com/searchchannels).

### Product training

For information on ABB product training, navigate to [new.abb.com/service/training](http://new.abb.com/service/training).

### Providing feedback on ABB Drives manuals

Your comments on our manuals are welcome. Navigate to [new.abb.com/drives/manuals-feedback-form](http://new.abb.com/drives/manuals-feedback-form).

### Document library on the Internet

You can find manuals and other product documents in PDF format on the Internet at [www.abb.com/drives/documents](http://www.abb.com/drives/documents).



[abb.com/drives](http://abb.com/drives)

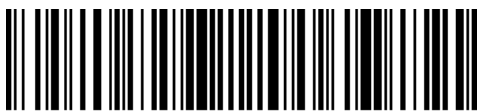

3AXD50000885664A