

INSTALLATION/MAINTENANCE INSTRUCTIONS

**Low Voltage  
Air-Magnetic Power Circuit Breakers**

---

**K-Line 225A through 2000A**

*Stationary and Draw-out Frames*

*Manually and Electrically Operated Mechanisms*



---

 TABLE OF CONTENTS

<b>INTRODUCTION .....</b>	<b>5</b>
Application.....	5
Designation .....	5
Safety Issues.....	5
Receiving, Handling, and Storage.....	5
<b>OPERATING FEATURES AND FUNCTION .....</b>	<b>7</b>
Anti-pump Lockout Relay (EO).....	7
Automatic Spring Discharge (EO).....	7
Automatic Trip Indicator .....	7
Automatic Trip Alarm Contacts (Optional) .....	7
Automatic Trip Lockout (Optional) .....	7
Close Button (EO).....	7
Close Handle (MO) .....	7
Close Lever (EO).....	7
Contact Position Indicator .....	7
Lifting Yoke (Optional) .....	7
Locking Hasp.....	7
Maintenance Handle (EO).....	8
Motor Disconnect Switch (EO).....	8
Nameplate .....	8
Racking Mechanism.....	8
Stored Energy Indicator (EO).....	8
Trip Buttons .....	8
<b>OPERATING DEVICES.....</b>	<b>9</b>
Auxiliary Switches.....	9
Control Relay Device .....	9
Magnetic Latch Device .....	9
Shunt Trip Device .....	9
Overcurrent Trip Devices.....	9
Electromechanical Overcurrent Trip.....	9
Solid-state Overcurrent Trip .....	9
Microelectronic Overcurrent Trip .....	9
Undervoltage Trip Device (Optional).....	10
<b>CIRCUIT BREAKER OPERATION .....</b>	<b>11</b>
Racking .....	11

<b>Charging Operation</b> .....	<b>11</b>
Electrically Operated Mechanism .....	11
Manually Operated Mechanism .....	12
<b>Closing Operation</b> .....	<b>12</b>
Electrically Operated Mechanism .....	12
Manually Operated Mechanism .....	12
<b>Opening Operation</b> .....	<b>12</b>
<b>Slow-close Procedure</b> .....	<b>12</b>
Electrically Operated Mechanism .....	12
Manually Operated Mechanism .....	13
<b>INSTALLATION AND REMOVAL</b> .....	<b>14</b>
<b>Stationary Type</b> .....	<b>14</b>
<b>Draw-out Type</b> .....	<b>14</b>
<b>MAINTENANCE</b> .....	<b>15</b>
<b>Inspection</b> .....	<b>15</b>
Arc Chutes.....	15
Contact Structure.....	16
Control Circuitry .....	16
Disconnects .....	16
Fasteners .....	16
Lubrication .....	16
Structural Insulation .....	17
<b>Setting Adjustments</b> .....	<b>17</b>
Contact Structure.....	17
Control Relay Device .....	20
Close Latch Release Rod Travel .....	20
Trip Latch Engagement.....	20
Tripper Bar Travel .....	20
Shunt Trip Device .....	21
Magnetic Latch Device .....	22
Electro-Mechanical Overcurrent Trip Device (OD).....	22
Solid-state Overcurrent Trip Device .....	23
Microelectronic Overcurrent Trip Device .....	23
<b>Operational Checks</b> .....	<b>23</b>
Draw-out Shutter and Racking .....	23
Auto Spring Discharge .....	23
Electrical Charging, Closing, and Opening .....	23
Trip-free Mechanism.....	23
Anti-pump Circuit (EO) .....	23
Magnetic Latch Release .....	23
Trip Latch Drag Force.....	24
Current Path Resistance .....	24
Insulation Withstand .....	24

---

**Renewal Parts..... 24**

These instructions do not purport to cover all details or variations or to provide for every possible contingency to be met in connection with installation, operation, or maintenance. Should further information be desired or should particular problems arise which are not covered sufficiently for the purchaser's purpose, the matter should be referred to the nearest District Office.

## INTRODUCTION

### Application

This instruction bulletin describes the features, operation, and maintenance of K-Line circuit breakers of 225 ampere through 2000 ampere frame sizes. Familiarize personnel with this bulletin before placing any circuit breakers into service.

These instructions apply to circuit breakers operated under the conditions listed in the ANSI Standard C37.13-1990 Section 2 (Service Conditions). Abnormal service conditions may require a derating of the circuit breaker or a modification to its application. For issues not addressed in this bulletin, contact the factory as indicated on the rear cover.

### Designation

A K-Line type designation identifies the circuit breaker accordingly by its rated continuous current, form of overcurrent protection, and physical construction. Reference the type and design ratings as shown on the circuit breaker nameplate.

K-Lines are used on AC and DC systems in two and three pole arrangements. Installation is stationary (STAT) or draw-out (DO) mounted. The energy charged in closing springs is either supplied manually (MO) with a single stroke handle, or electrically (EO) with a spring charging motor.

Overcurrent protection is available with an electromechanical (OD), solid-state electronic (Power Shield), or microelectronic (MPSC-2000) trip system. ABB trip systems are direct acting; actuating power is obtained from the protected power system rather than relying on an external source.

Note: The MPSC-2000 trip device has superceded the MPS and MPS-C trip devices.

Note: DC service protection is available only with an electromechanical trip system.

Several combinations of options may be present on a given circuit breaker. Consult the factory with questions regarding non-standard options.

### Safety Issues

Throughout the manual, there are three terms that must be heeded, for the following safety reasons:

#### CAUTION

*Not adhering to these instructions may result in equipment damage or malfunction.*

#### WARNING

*Not adhering to these instructions may result in serious injury and equipment damage.*

#### DANGER

*Not adhering to these instructions may result in life threatening injury and permanent equipment damage.*

All circuit breakers have been equipped with safety interlock systems that must never be defeated:

- *Interference Blocking* – physically prevents installation of a breaker into an incompatible enclosure.
- *Racking Shutter* – denies racking handle access to a breaker unless the breaker is both open and in one of the three racking positions: CONNECTED, TEST, or DISCONNECTED.
- *Automatic Spring Discharge* – discharges charged closing springs if breaker is racked to the DISCONNECTED position.

### Receiving, Handling, and Storage

Upon receiving your order, examine the cartons for damage sustained during transit. If rough handling is evident, immediately file a damage claim with the carrier and promptly notify the ABB District Sales Office. ABB disclaims responsibility for damages sustained after delivery to the carrier; however, we will lend assistance if notified of a claim.

Unpack circuit breakers after receipt. Delayed unpacking may hamper a claim for damages not evident upon receipt. Be careful not to inflict damage while opening the shipment. Compare the carton contents against the packing list before discarding packaging. Promptly notify the ABB Sales Office concerning any discrepancies. Accompany a claim with purchase order number, carton number, and a description of damaged or missing parts. Keep the circuit breaker upright on a flat surface to avoid damage to breaker parts.

Install circuit breakers in their permanent location as soon as possible. Until used, the circuit breaker should be stored and locked in the DISCONNECTED position inside its compartment with the door closed. Both the primary and control circuits are disconnected in this position. Use a lifting yoke for safe and convenient installation. If the breaker cannot be installed in its compartment, then seal it in the original carton to prevent dirt infiltration. Where conditions of high humidity prevail, the use of heaters is recommended during storage.

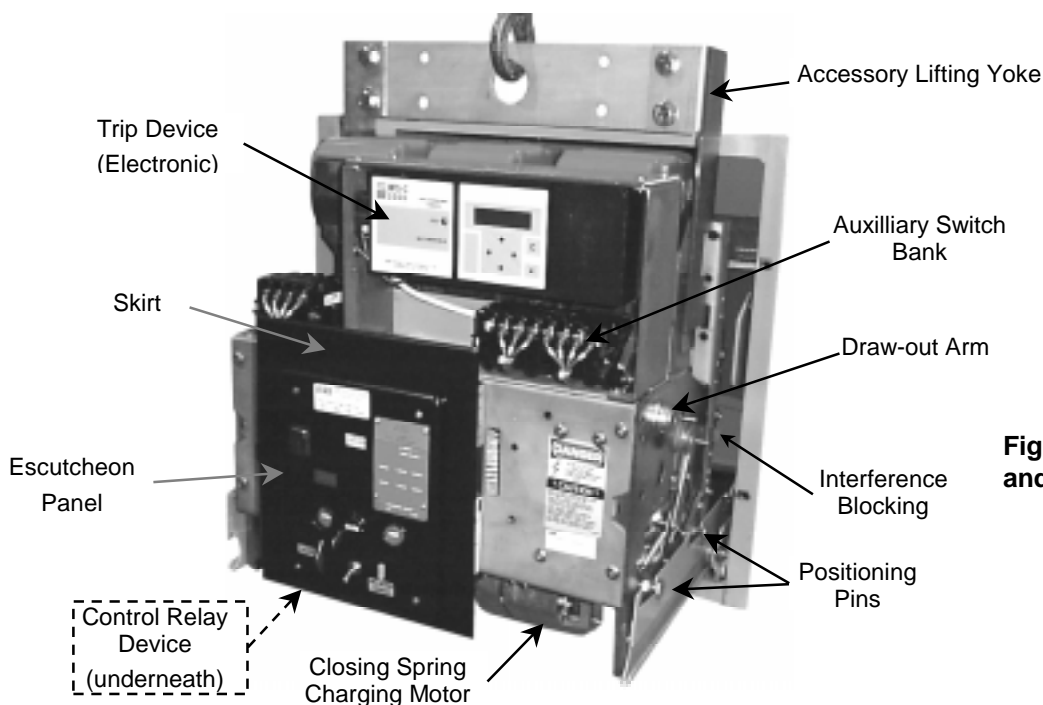

**Figure 1a. Type K-1600M Circuit Breaker with Electrically Operated Mechanism and Draw-out Frame Construction.**



**Figure 1b. Accessory Racking and Maintenance Handles.**

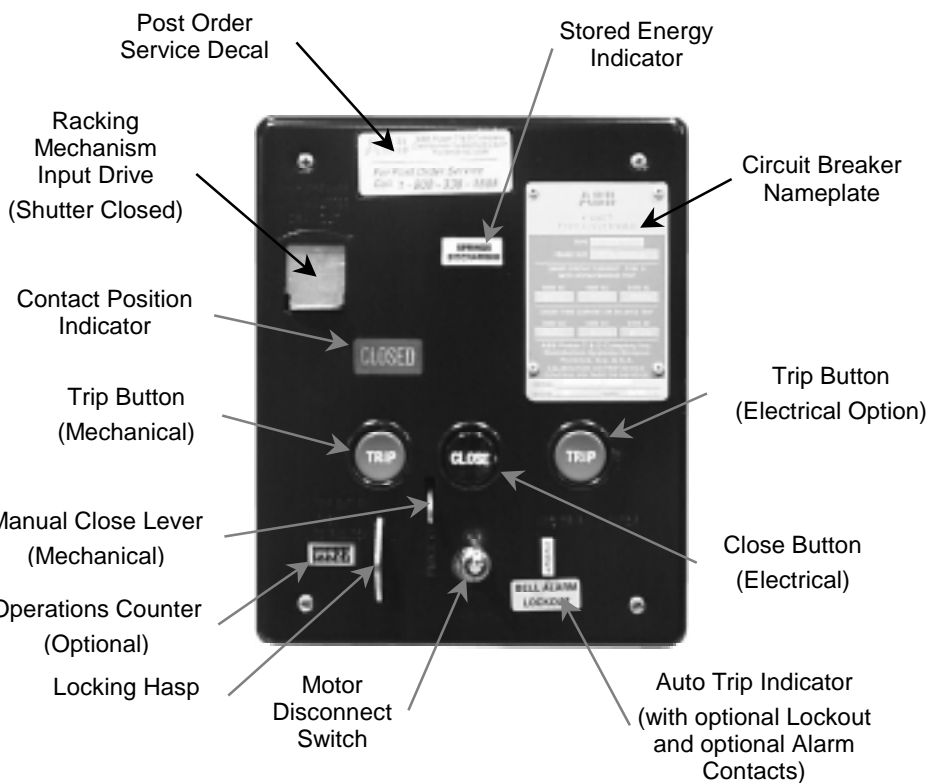

**Figure 1c. Escutcheon Panel.** Arrangement for an EO breaker as shown (MO panel is similar).

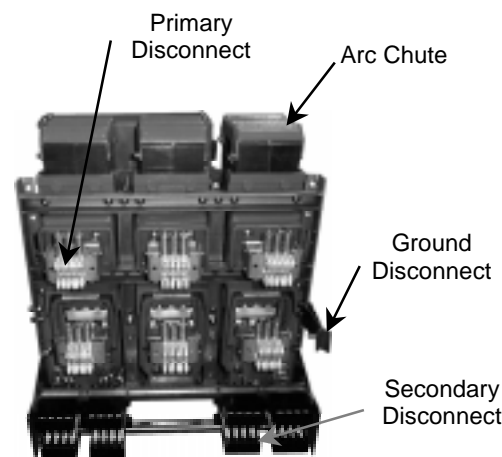

**Figure 1d. Primary and Secondary Disconnects.** 1600 Ampere primary disconnects shown (800 Ampere and under are typical).



**Figure 1e Disconnects.** 2000 Ampere primary disconnects shown.

## **OPERATING FEATURES AND FUNCTION**

The escutcheon panel is the local interface with the operation of the circuit breaker. On draw-out breakers, the panel will extend beyond the front door of the compartment when the breaker is in the TEST and DISCONNECTED positions.

See the illustrations of Figure 1 for feature location. Note that not all features are found on a particular breaker depending on the type designation.

### **Anti-pump Lockout Relay (EO)**

(Not illustrated - internal feature)

The lockout relay functions within the control relay device. The relay prevents subsequent circuit breaker closure until the previous close signal is first released and then reapplied. Anti-pump circuitry prevents repeated open-close cycling during a trip-free condition or reclosing onto an automatic trip event.

### **Automatic Spring Discharge (EO)**

(Not illustrated – internal feature)

Electrically operated draw-out breakers are designed to discharge the closing springs when a breaker is racked into the DISCONNECTED position. This internal feature prevents inadvertent breaker closure while handling the breaker outside of the enclosure. The spring discharge occurs just before reaching the DISCONNECTED position. The springs will not store a new charge until the breaker is moved out of the DISCONNECTED position.

*Note:* In early model draw-out breakers [prior 1970], the closing springs are automatically discharged when the breaker is pulled to the fully withdrawn position. A ramp on the cubicle floor drives the close latch release rod (on the control relay device) as the breaker is withdrawn from the switchgear.

### **Automatic Trip Indicator**

This is a white indicator marked “RESET”. It is spring-loaded in the latched position, popping out upon automatic tripping. The device only indicates tripping during an automatic event. The cause for indication should be investigated before resetting the trip indicator and subsequently re-closing the circuit breaker. Reset the indicator by physically pushing it back into its normally latched position. This feature may be coordinated with a lockout feature.

### **Automatic Trip Alarm Contacts (Optional)**

A microswitch coordinated with the automatic trip indicator provides remote indication of an automatic trip event. The trip indicator actuates a roller on the alarm switch during an overcurrent trip. Resetting the automatic trip indicator also resets the alarm contacts.

### **Automatic Trip Lockout (Optional)**

Following a fault, the lockout places the circuit breaker trip-free by holding the tripper bar paddle in the trip position. The circuit breaker cannot be closed until the indicator is manually reset on the breaker.

### **Close Button (EO)**

The close push button electrically operates the close coil (X) in the control relay device. The armature of this coil actuates the close latch release rod. The rod actuates the close latches, allowing the closing springs to operate the breaker mechanism. When no control power exists, the manual close lever must be used to close the circuit breaker.

### **Close Handle (MO)**

(Not illustrated)

The T-shaped handle both charges the closing springs and closes the contacts of a MO circuit breaker in one sequence. The closing speed is independent of the handle action. The closing handle also performs the slow-close operation used for simultaneous contact adjustment (see *Slow-close Procedure*).

### **Close Lever (EO)**

The close lever manually closes an EO breaker by mechanically actuating the close latches. MO breakers do not have this lever since the mechanism charges and closes in one operation.

### **Contact Position Indicator**

This mechanical flag indicates the status of the breaker contacts as either “OPEN” or “CLOSED.”

### **Lifting Yoke (Optional)**

Use a lifting yoke to safely install a breaker into switchgear. The yoke hooks into the vertical frame channels as shown in Figure 1a. The bolted construction allows the yoke to be used for both small and large frame breakers. If a yoke is unavailable, use chain hooks in the upper hole of the vertical frame channels.

### **Locking Hasp**

All K-Line circuit breakers are equipped with a provision for padlocking the mechanism in an open, trip-free condition in any of the draw-out positions. The hasp accepts one or more padlocks. When locked, the trip-free condition results from the engagement of the manual trip button linkage.

To lock the breaker open:

1. Trip the breaker open.
2. Depress and hold the mechanical trip button, then pull the locking hasp outward.
3. Insert lock(s).

When locked, a breaker can neither be racked between positions nor closed. For EO breakers,

attempted closure will only discharge the closing springs. With MO breakers, the closing handle action will not engage the closing springs.

### **Maintenance Handle (EO)**

Shown in Figure 1b, the maintenance handle is used for charging the closing springs of motor-driven mechanisms when control power is not available. It is also used for adjusting the simultaneous contact make during a slow-close operation.

### **Motor Disconnect Switch (EO)**

Used only on electrically charged mechanisms, the motor disconnect switch (MDS) is wired in series with the spring charging motor circuit. The switch serves two functions:

1. Stops the normal sequence of recharging closing springs following a breaker opening (without de-energizing the control power source).
2. Isolates the motor from the control wiring when withstand-voltage testing the control wiring (which is tested at a higher voltage than the motor itself).

Remember to leave the switch ON after returning a breaker to service.

### **Nameplate**

The nameplate identifies the rated performance limits of the circuit breaker as certified per design. Do not exceed these limits. The nameplate also lists the

circuit breaker model type, frame size, and serial number. Provide the serial number when contacting ABB for information.

### **Racking Mechanism**

Utilize a racking handle, as shown in Figure 1b, to operate the racking mechanism of draw-out circuit breakers. The racking mechanism moves a draw-out type circuit breaker between any of three positions: CONNECTED, TEST, or DISCONNECTED. Position is indicated by a decal in two places: the left upper cradle arm (open cubicle door) and on the escutcheon box right-side (closed cubicle door). The racking shutter is interlocked with the position of the breaker contacts to deny handle insertion unless the breaker is open. Additionally, the circuit breaker is trip-free between racking positions.

### **Stored Energy Indicator (EO)**

This mechanical flag indicates the stored energy condition of the closing springs. The two states of the flag are marked "SPRINGS CHARGED" and "SPRINGS DISCHARGED."

### **Trip Buttons**

All breakers have a mechanical push button trip for opening the breaker locally. A second optional trip button electrically operates the shunt trip for locally opening the breaker.



## OPERATING DEVICES

### Auxiliary Switches

The switches are furnished in 4 or 8 contact banks. With the opening and closing of the breaker, a jackshaft driven linkage operates the rotary switch contacts between the open and closed position. By designation, "a" contacts are synchronized with the breaker contact position (normally open when the breaker is open). The "b" contacts are arranged oppositely (closed when the breaker is open). If desired, an "a" contact can be made into a "b" contact (and vice versa) by opening the switch and rotating the contact element 90°.

### Control Relay Device

A control relay device is furnished on EO circuit breakers. The electromechanical device mounts to the left bottom edge of the mechanism front cover. Three electrical components are housed:

1. Limit Switch, "LS" – Cycles the closing spring motor power.
2. Lockout Relay, "Y" – Actuates the anti-pump circuitry.
3. Latch Release Relay, "X" – Operates the close latch release rod.

The device base also serves as a terminal block for much of the circuit breaker wiring. Reference Table A2 of Appendix A for applicable control characteristics. Reference Figure A1 of Appendix A for a control wiring schematic.

### Magnetic Latch Device

The magnetic latch device receives a trip signal from the electronic trip unit. A permanent magnet latches the device plunger against a compressed spring. When energized by a trip signal, the device coil momentarily cancels the magnet's field, releasing the plunger and opening the circuit breaker.

### Shunt Trip Device

The shunt trip is employed for opening the breaker on command. It is energized remotely through the secondary disconnect contacts or locally with the optional electric push trip button. When energized, the shunt trip coil actuates the device trip rod, which strikes the trip latch, opening the breaker. Reference Table A2 of Appendix A for applicable control characteristics.

### Overcurrent Trip Devices

All overcurrent trip devices must be uniquely coordinated to the system for which the breaker is intended to protect. Use appropriate trip settings and reference the pertinent time-current curves for delay

times. The time delay will fall within the limits of the graphed time bands, subject to the notes therein.

The tolerance for a trip event at a pickup setting is:

- Long-time:  $\pm 10\%$
- Short-time:  $\pm 15\%$
- Instantaneous:  $\pm 20\%$
- Ground:  $\pm 15\%$  (not available with OD)

Refer to Tables B1, B2, B3, and B4 of Appendix B for standard device types, testing, and applicable time-current curve references. For non-standard trip devices not listed, consult ABB.

#### *Electromechanical Overcurrent Trip*

These devices are commonly referred to as "OD" (oil displacement) devices because many have a long-time delay element that utilizes a dashpot. The device consists of a primary current coil assembly, laminated iron circuit, and mechanical parts that actuate the calibrated device. The coil assembly mounts in series with the current path of each phase. Magnetic flux develops in the iron circuit and across an air gap at one end of a pivoting leg. Each trip element: long-time, short-time, and instantaneous has an adjustable tripping current level (pickup). At the currents marked on the nameplate, the device is calibrated to "pick up" the open pivoting leg. The resulting motion trips the breaker through tripper bar actuation. Tripping is delayed by dashpot oil displacement for long-time overcurrent events. A mechanical gearbox delays tripping for short-time overcurrent events. No intentional delay was designed for instantaneous overcurrent events.

#### *Solid-state Overcurrent Trip*

The Power Shield<sup>®</sup> solid-state overcurrent trip system uses analog circuitry to monitor system power. Each breaker phase has two sensors: a power sensor to supply the trip system and a current sensor for producing current proportional to the primary circuit. During an automatic trip event, the trip device signals the magnetic latch to open the circuit breaker.

In addition to long-time, short-time, and instantaneous protection, the introduction of a solid-state trip device made ground fault protection available. The functions have selectable time delay and tripping thresholds. Combinations of tripping elements are specific to the device type.

#### *Microelectronic Overcurrent Trip*

The Micro Power Shield<sup>®</sup> designs employ digital circuitry and software driven microelectronics to protect system power. Having a similar physical arrangement and function as the solid-state trip system, the microelectronic trip systems use one sensor to both power the trip system and provide a current signal for fault monitoring. Systems with

communications ability also offer voltage, current, and power imbalance information.

#### **MPS (Discontinued)**

The first of the microelectronic systems, protection settings were made with switches on the face of the device. Combinations of long-time, short-time, instantaneous, and ground trip events were specific to each device type.

#### **MPS-C (Discontinued)**

The MPS-C incorporated a communications interface with the MPS device. A Network Interface Module is needed to communicate with the trip device. Like the MPS trip system, permutations of long-time, short-time, instantaneous, and ground trip events were specific to each device type.

#### **MPSC-2000**

The MPSC-2000 combined all tripping elements in one device. Instantaneous or short-time (not both together), ground, and  $I^2t$  elements are defeatable to obtain desired coordination. Instead of mechanical switches, the MPSC-2000 utilizes a LCD for device interface. Menus allow the user to view real-time metering information, review protection settings, modify protection settings with password authorization, and review operational history. Fault event history and device settings are recorded in non-volatile EPROM memory.

MPS-C and MPSC-2000 units can be tested with the BTSB (Bench-top Trip Simulator for Breakers) both

on and off the breaker. Tested on the breaker, the BTSB can also operate the magnetic latch as part of the fault simulation. When testing the MPS-C, the BTSB interactively guides the user through the test sequence. When testing the MPSC-2000, the BTSB runs all tests unassisted and restores the original settings after test. Results are stored in non-volatile memory and may be reviewed on-screen or sent to a printer. The test set also has a port for downloading future software upgrades.

#### **Undervoltage Trip Device (Optional)**

The undervoltage trip device automatically trips the circuit breaker when the supplied voltage decreases to between 30% and 60% of the rated voltage. The device resets when the supplied voltage restores to 80% of its nominal value. This device can be furnished either for instantaneous trip operation or with an adjustable time delay, actuating between 1.5 to 15 seconds.

The device coils normally operate continuously to keep the device armature picked-up. Following undervoltage drop-out, the breaker remains trip-free until voltage is restored and the device picks-up again. Undervoltage devices normally open a breaker through tripper bar actuation, but may be configured (non-standard) to trip the latch directly.

Refer to Table A3 of Appendix A for device characteristics.

## CIRCUIT BREAKER OPERATION

In principle, all K-Line circuit breakers cycle through three stages of operation: charging, closing, and opening. The charging and closing stages differ between MO and EO mechanisms in that a MO mechanism does not intermediately store charged closing spring energy.

### Racking

Draw-out breakers are racked between positions of DISCONNECTED, TEST, and CONNECTED. Reference the decal either on the escutcheon box right-side (door closed) or on the left cradle arm (door open). Using the decal as a reference, the breaker is properly in position when the racking shutter closes after handle removal.

Within the breaker, an index cam interlocks the racking mechanism with the breaker contact position. The shutter prohibits racking handle access to the drive input until the breaker is opened. Additionally, the shutter must fully close in each position, because the interlocking places the mechanism trip-free between draw-out positions. For EO breakers, attempted closure will discharge the charged closing springs without driving the breaker mechanism. With MO breakers, the closing handle will not even engage the closing springs. The interlocking prevents connecting or disconnecting a closed breaker with an energized circuit.

*Placing a draw-out breaker into service:*

1. Open the breaker.
2. With the breaker mounted on extended rails, turn the racking handle fully CCW (counter-clockwise). Push the breaker into the cubicle. The draw-out arm roller on both sides of the breaker engages with the track of the cradle.
3. Turn the racking handle CW (clockwise); placing the breaker into the TEST position. Make pre-operative checks.
4. Completely turn the handle CW until the racking mechanism stops, placing the breaker in the CONNECTED position. A momentary resistance to motion will be noticed as the spring-loaded disconnects engage the cubicle stabs.

*Removing a draw-out breaker from service:*

1. Place the motor disconnect switch (if equipped) in the OFF position to prevent subsequent closing spring recharging after breaker opening. Open the breaker.
2. Rotate the handle CCW, placing the breaker in the TEST position.
3. Rack fully CCW into the DISCONNECTED position. If the closing springs are charged, the automatic spring discharge feature will discharge

the charged closing springs within the last few turns of the handle.

### Charging Operation

The potential energy of charged closing springs close the circuit breaker contacts. Electrically operated mechanisms store spring energy until triggered to close. Manually operated breakers both charge and close in one sequence.

#### *Electrically Operated Mechanism*

The charging motor charges the closing springs. Under a normal wiring configuration as illustrated in Figure A1 of Appendix A, the motor will charge the closing springs of an open breaker having control power, unless the MDS is positioned OFF. The closing springs discharge in the process of closing the circuit breaker. Upon closing, the L/b contact at terminals 1 and 2 opens, preventing power to the motor through the closed LS/1 charging spring limit switch. Upon opening, the L/b contact closes and the breaker immediately recharges its closing springs for re-closure. Some charging circuits are configured without the auxiliary switch contact L/b at terminals 1 and 2, in which case the charging springs immediately recharge after closing the circuit breaker. An anti-pump relay within the control relay device prevents repetitive breaker closure if a close input is maintained during a trip-free condition.

### CAUTION

**Do not forget to leave the motor disconnect switch ON after maintenance, else the breaker cannot be charged electrically for subsequent closure.**

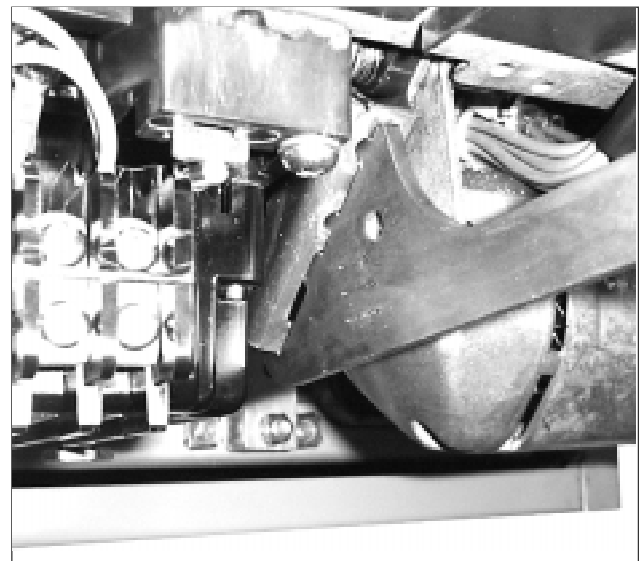

**Figure 2. Maintenance Handle Engagement.**

Use the Maintenance Handle accessory to manually charge the closing springs when control power for the

motor is unavailable. Engage the handle with the drive carrier as demonstrated in Figure 2. Charge springs by ratcheting the carrier with a smooth, deliberate motion. Charge until a latching sound is heard as the closing springs snap over-center. At this point, the carrier no longer engages teeth of the driven gear and the stored energy indicator will display "SPRINGS CHARGED".

The loaded action of the drive carrier occasionally back-drives the motor crank arm into a position that holds the carrier at partial stroke. The crank arm must be physically rotated to allow the carrier to cycle and engage the next tooth of the charging gear. With Ametek motors, this can be accomplished by forcing the carrier upward against the resistance of the motor gearing. Because of the higher gearing torque of the Ryobi charging motor, resetting the carrier is most easily accomplished by rotating the motor armature.

### **DANGER**

*The motor must be isolated from control power before attempting to turn the armature. Beware of a hot commutator if the motor was just operated. Do the following:*

- *Rack the circuit breaker to the DISCONNECTED position to isolate it from the control circuit. (Stationary breakers must have the control circuit de-energized).*
- *Wearing a glove (measure of safety), rotate the armature by turning it at the exposed commutator.*

### **Manually Operated Mechanism**

Circuit breakers with a MO mechanism are operated with the T-shaped closing handle. The mechanism closes the breaker independent of handle operating speed. In one operation, the closing springs both charge and then discharge to close the breaker without an intermediate stored energy condition. Manually operated mechanisms therefore do not have a close control circuit, close latching, or an automatic spring discharge feature.

### **Closing Operation**

#### **Electrically Operated Mechanism**

The energy of discharged closing springs drives the breaker mechanism to close the breaker contacts. Closure is initiated locally at the escutcheon panel or remotely by electrical means.

Standard equipment allows closing at the escutcheon panel using either the mechanical close lever or the electrical push button close. The close button actuates the release (close) coil in the control relay device. Remote closure uses the same release coil circuit.

#### **Manually Operated Mechanism**

Manually operated breakers are closed at the end of the charging cycle during the continuous handle motion described in the charging section.

### **Opening Operation**

The loaded contact springs and two charged opening springs provide the energy for opening the circuit breaker. Opening is either manual or automatic. Manual opening is performed locally with the mechanical push button trip or the optional push button electric trip. The push button electric trip actuates the shunt trip device. Remote opening uses the same shunt trip circuit. Automatic tripping is initiated with an overcurrent or undervoltage device.

As visualized in Figure 8, depending on the mode of circuit breaker opening, the secondary trip latch operates either independently or dependently with the tripper bar. Shunt tripping and mechanical push button tripping operate the latch directly without using the tripper bar. Overcurrent and undervoltage devices actuate the tripper bar, which in turn rotates the secondary trip latch. This distinction discriminates between an intentional opening and an automatic trip event because the tripper bar also actuates the automatic trip indicator.

### **Slow-close Procedure**

The purpose of the slow-close procedure is for checking the travel of the contact assemblies and adjusting the simultaneous-make between poles.

### **WARNING**

*The circuit breaker should be clamped down during the slow-close procedure to keep it from tilting while manually charging the closing springs.*

### **Electrically Operated Mechanism**

### **CAUTION**

*The charging cranks must be reset after the last slow-close operation or future electrical operation will be impossible (see steps #8, #9 and #10 below).*

1. Charge the closing springs electrically or manually and observe the closing spring charge indicator. Turn off the motor disconnect switch.
2. Referencing Figure 3, insert a screwdriver through the hole in the escutcheon box and depress the close block pin lever downward.
3. With the close block pin lever held in the down position, initiate closure with the manual close lever. Instead of the breaker closing, the spring load transfers to the close block. The close block pin lever will remain in the down position.
4. Insert the maintenance handle in the motor drive carrier as shown in Figure 2. Slowly close the breaker contacts by actuating the handle.

To repeat the slow-close operation, continue with the following steps:

5. Re-insert the maintenance handle and complete the charging cycle until the indicator shows "SPRINGS CHARGED" (may already be the case as in step #4).

6. Open the breaker with the manual trip button.
7. Resume slow closing with steps #2, #3, and #4.

Referring to the previous warning, reset the charging cranks for normal electrical operation as follows:

8. Repeat previous steps #5 and #6.
9. Lift manual close lever to close the contacts.
10. Push the manual trip button to open the contacts.

The closing springs are now discharged with the charging cranks reset. Restore power to the charging motor with the MDS in the ON position. The mechanism is ready for electrical operation.

**Manually Operated Mechanism**

1. On 1600 and 2000 ampere breakers, at each of the two spring guards, loosely install 1/4" diameter pins or machine screws as shown in Figure 4 (not necessary for 800 A and under frame sizes).
2. Insert a screwdriver through the hole in the escutcheon box and mechanism housing assembly (right-hand side when facing the front of the circuit breaker.)
3. Using the top of the hole as the fulcrum and a screwdriver or rod as a lever, depress the hold-up latch. At the same time, pull the operating handle forward enough to engage the slow-close latching, then work the handle in one stroke to move the contacts through the open-to-close range.

**WARNING**  
*Keep a firm grip of the handle, which is loaded with the energy of the mechanism when slow closing.*

4. Remove the two 1/4" diameter pins or machine screws installed in step #1 after the slow-close operation is complete, else the mechanism cannot be charged and closed in the normal operating mode.

Note: The step #1 operation, as illustrated in Figure 4, is not necessary for adjusting the simultaneous-make. However, without the temporary pins, the breaker will not latch closed.

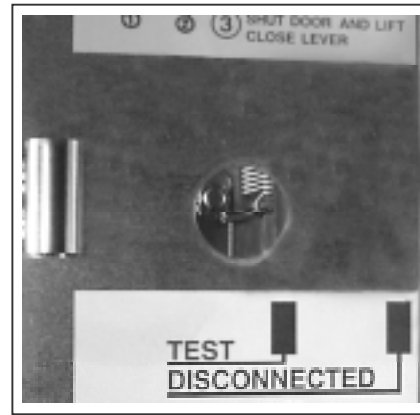

**Figure 3. Slow-close Lever on EO breakers.** Located on the escutcheon box right-side. Depress lever with a screwdriver.

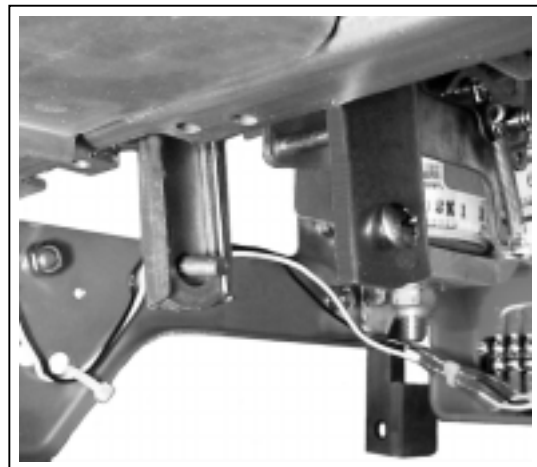

**Figure 4. Temporary Screws.** Installed for slow-close latching 1600 and 2000 frame size MO breakers.

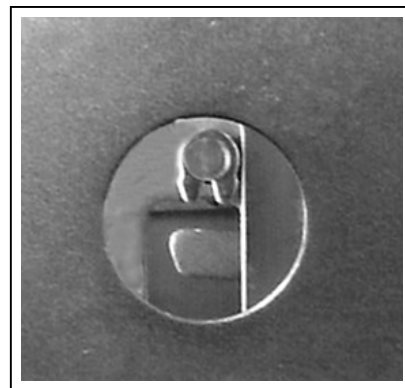

**Figure 5. Slow-close Lever on MO breakers.** Located on the escutcheon box right-side. Depress lever with a screwdriver.

## INSTALLATION AND REMOVAL

**NOTE:** If a breaker with OD devices has been shipped or stored on its back, then oil in the dashpot might have been displaced and an air bubble trapped under the piston. Before installing the breaker, with the breaker in the upright position, exercise the long-time armature of each breaker phase (the 5/8" wide armature) several times until resistance to motion has increased. Resistance indicates that air entrapment has cleared and the oil dashpot is functioning properly.

### CAUTION

**Do not lift the breaker by the primary disconnects. Use a chain and hooks in the top hole of the vertical frame channels or a lifting yoke. Be careful not to damage the disconnects when installing or removing a breaker in the switchgear.**

### Stationary Type

#### DANGER

**When installing or removing stationary breakers, the supply for primary and control circuits must be de-energized at all times. Testing of stationary circuit breakers must be done with the primary supply circuit de-energized.**

A lifting yoke should be used to move the breaker to the switchboard. Other handling means may be required to move the breaker into position inside the switchboard.

### Draw-out Type

When moving between positions, confirm that the racking shutter closes fully after removing the handle. If it closed partially, then the breaker is not yet fully in position.

For initial installation of draw-out breakers into the CONNECTED position, the supply for the primary circuit should be de-energized (even though the breaker will be open). Perform any operational tests in the TEST position.

*Proceed as follows to install and connect a circuit breaker in its compartment:*

1. The circuit breaker must be in the open position, the racking mechanism cranked fully in the CCW direction against its stop, and the motor disconnect switch (EO circuit breakers) in the OFF position.
2. Open the compartment door and pull out the right-hand and left-hand cradle rail to the fully extended and latched position.
3. Using a lifting yoke, lower the circuit breaker so that the positioning pins, two on each side of breaker, rest in the cut-out sections of each rail.
4. Remove the lifting yoke and push the circuit breaker toward the compartment. The breaker will slide on its positioning pins to the rear of the cut-out sections in the rails. An additional push will overcome the two cradle latches allowing the circuit breaker to move into the DISCONNECTED

position. The draw-out arm of both sides will make initial cradle engagement.

5. Lift the racking shutter, insert the racking handle, and crank CW. Rack from the DISCONNECTED position into the TEST position. Make operational checks as described in the Maintenance Section before placing the breaker in the CONNECTED position for online service.

*Proceed as follows to rack a CONNECTED circuit breaker into the TEST position:*

1. With the compartment door closed, trip the circuit breaker open.
2. Lift the racking shutter and insert the racking handle. Rack CCW until the decal on the right-hand side of the escutcheon indicates the TEST position. **NOTE:** This position was designed for making operational checks. The control circuit is energized, but the primary disconnects are not connected.

*Proceed as follows to disconnect and remove a circuit breaker from its compartment:*

1. Turn the motor disconnect switch OFF. If closed, open the breaker. Draw-out CCW until the racking mechanism reaches its stop. If the mechanism is charged, expect an automatic spring discharge just before reaching the fully DISCONNECTED position (EO breakers).
2. Pull the circuit breaker forward until both cubicle rails are in the fully extended and latched position.
3. Position a lifting yoke. To keep the yoke hooked into the breaker, partially lift the circuit breaker weight.
4. With a positive pull, slide the breaker forward on its positioning pins in the track of both rails. Notice that the track for the positioning pins has a locking action in both ends of the cut-out. If the breaker is slid too far forward, it will remain secured in the rails.
5. Lift the circuit breaker from the rails.
6. Release the latch on each rail and push the rails back into the compartment. Keep the compartment door closed.

**MAINTENANCE**

This section provides guidelines applicable under the normal operating conditions referenced in the *Introductory* section. Where unusual service conditions exist, ABB presumes that these conditions were considered at the time of order, the equipment supplied was designed for the special application, and an appropriate supplemental maintenance program had been developed.

Maintenance frequency should be based on factors that influence the circuit breaker operating condition over a period of service. The operating condition is predominantly a function of the circuit duty and the circuit breaker environment. The merit of a maintenance schedule should be based on service records specific to the breaker’s application. ABB recommends the schedule shown in Table 1 until a service history is established for the circuit breaker. Perform maintenance before the number of operations or time elapsed since the last maintenance interval, whichever comes first. This schedule may be altered at the user’s discretion based on actual performance. On a new circuit breaker, ABB recommends inspection within the first year of service, regardless of the number of operations.

Maintenance programs should consist of inspection, cleaning, adjustments, and operational checks as recommended or when affected by other adjustments. Adjustment is not required for most devices unless removal of another device so affects it.

**DANGER**

*Beware of electrical hazards. Remove a circuit breaker from service (CONNECTED) before attempting any maintenance activities. Draw-out circuit breakers must be withdrawn to the TEST position before any operational checks and withdrawn from the cubicle for inspection, adjustment, or repair. Stationary breakers must be de-energized from the primary circuit before any operational testing and also from the control circuit before any inspections or repair.*

**WARNING**

*Beware of mechanical hazards. Stay clear of moving parts and take precaution with the use of tools when operating the circuit breaker. Notice whether or not the breaker is open or closed by observing the contact position indicator. Check the charge status of the closing springs by observing the stored energy indicator. A charged breaker has the potential to inadvertently close; likewise, a closed breaker may surprisingly open.*

**WARNING**

*Do not work on a draw-out circuit breaker withdrawn on extended cubicle rails.*

**Table 1. Maintenance Schedule Based on Circuit Duty and Circuit Breaker Environment.**

Frame Size	Load Current Switching (Duty ≤ Continuous Current Rating)				Motor Starting or Capacitor and Reactor Switching	
	Clean Environment		Typical Environment		Any Environment	
	Operations	Years	Operations	Years	Operations	Years
225, 600, & 800	1750	5	1000	3	1000	3
1600 & 2000	500	5	300	3	300	3

In addition to Table 1, inspect a breaker after short-circuit interruption as soon as possible. Examine the arc chutes, the condition of the contacts, and check the contact pressure before continued service.

ABB recommends circuit breaker refurbishment when the circuit breaker achieves its designed mechanical endurance limit or the period of service as shown in Table 2

**Table 2. Full Refurbishment Schedule**

Frame Size	Total Operations	Service Period (Years)
225, 600, & 800	12,500	10
1600 & 2000	4000	10

To minimize down-time, stock commonly needed spare parts as suggested in the *Renewal Parts* section.

**Inspection**

Inspect the general condition of the breaker and enclosure. Initial observations are worth recording for subsequent troubleshooting and a general feel for the adequacy of the maintenance program. Inspect the enclosure floor for broken hardware or fallen parts. After initial assessment within the enclosure, rack the circuit breaker out for further inspection.

**Arc Chutes**

The chutes are secured with a screw and a poly-glass retainer as mounted between the poles. Check the

tightness of these retainers at the recommended maintenance intervals. Install chutes as follows:

1. Remove the electronic trip unit to access the retaining hardware (if applicable).
2. Remove the screws and retainers. Tilt each arc chute forward at the top and lift to remove.
3. Install in reverse order. Do not overtighten the screws to avoid breaking the retainer or chutes. Tighten screws to a maximum of:

Frame Size	Maximum Torque
225, 600, & 800	20 lb-in
1600 & 2000	75 lb-in

Look at the damage that service has impacted on the chutes. Examine the arc chute exterior and the arcing chamber. Soot, uniform erosion, and discoloration are normal observations associated with arcing.

Replace a chute when any:

- The stationary arc runner has significant erosion.
- Arc splitters have burn-through holes.
- Moldings have broken functional features that retain arc splitters or baffle parts.
- Shell moldings have mating surface defects that may allow interrupting gases to escape (flashover potential).

Clean outside shell and arcing chamber region with a clean cloth and denatured alcohol.

### Contact Structure

Examine contact members for cracks and erosion. Replace members with body cracks or broken sintered contacts. Consider replacement of an arcing contact member when the thickness of the sintered arcing material has eroded to less than 50% of its new thickness. Replace a main contact member if it has erosion that cannot be dressed sufficiently to re-establish a smooth surface. Likewise, inspect the condition of the stationary contacts for erosion. Check the mating primary disconnect surface of the terminal studs for signs of burning.

If contacts need conditioning:

1. Avoid getting debris into the mechanism during the cleaning and dressing process.
2. Remove bulk residue on contacts with a lint-free cloth. Remove small burrs on contacts by filing along the contour of the contact. Clean with denatured alcohol.
3. Re-establish proper contact pressure and simultaneous-make.

### Control Circuitry

Inspect wiring for damaged insulation. Clean any grease from the insulation. Check that wire routings are protected from sharp edges. Confirm that lugs

and terminals are securely fastened. Confirm correct wiring with preoperative checks that use the connected device. If an electrical malfunction is detected, compare the physical wiring configuration against the schematic diagram of Figure A1 of Appendix A. Test dielectric integrity with a Withstand-Voltage Test as outlined in the *Insulation Withstand* section.

### Disconnects

Inspect the primary disconnects for corrosion and signs of over-heating. Remove the old NO-OX-ID "A-Special" grease using a petroleum solvent (as suggested by Sanchem) followed by a clean cloth and denatured alcohol. Confirm that assemblies were not damaged while servicing the breaker. Reapply the NO-OX-ID "A-Special" only to the switchgear end of the primary disconnect assemblies where sliding contact occurs.

Inspect the secondary assemblies for a broken plastic housing. Wipe clean, but do not lubricate the secondary disconnect contacts. Identification of the contacts can be determined from Figure A2 of Appendix A.

### Fasteners

Check the circuit breaker for loose, broken, or missing fasteners. Locking type fasteners should be replaced when removed. Torque hardware when indicated in the bulletin.

### Lubrication

Inspect existing grease to determine whether it should be replaced. Discolored grease indicates oxidation and contamination. Dry, caked grease has no lubricating qualities and must be replaced.

As supported by service history and periodic endurance testing, use only the greases approved by ABB for use in K-Line circuit breakers. The approved greases and application are as follows:

1. NO-OX-ID "A-Special" grease manufactured by Sanchem, Inc. is a corrosion and water inhibitive coating applied to the mating and working surfaces of primary current path parts. Maintain application on the primary disconnects, contact structures, and any other primary current path parts during maintenance intervals. Do not apply NO-OX-ID "A-Special" to any secondary circuitry.

### CAUTION

*Do not apply NO-OX-ID grease on the parting surfaces of the main or arcing contacts; may increase the interface resistance, as well as, collect contaminating debris. The wiping action and contact pressure were designed to maintain the interface.*

2. Anderol 757 synthetic grease manufactured by Huls America, Inc. is applied to moving surfaces and for packing bearings.
3. Mobil 28 grease as an alternative to Anderol 757 (for refurbishment only). ABB strongly



recommends using only one type of grease throughout the breaker.

### CAUTION

*Anderol 757 and Mobil 28 are substantially incompatible greases. Before relubricating parts with either grease, thoroughly remove the existing lubricant. Furthermore, parts ordered for replacement are lubricated with Anderol 757, which must be removed before use with Mobil 28 lubricant.*

### CAUTION

*Do not apply grease to the latching or roller surfaces of either the primary or secondary trip latches. The working surfaces were designed without grease that will otherwise collect debris.*

When operated by the schedule of Table 1, K-Line circuit breakers should not need renewed application of grease to parts between scheduled maintenance intervals. Reapply grease when parts are removed, replaced, or cleaned. Wipe away excess grease outside of working surfaces. If the service environment has unduly contaminated the lubricant, then cleaning and reapplication may be necessary. Proper re-lubrication requires disassembly and thorough cleaning before applying new grease. Thoroughly wash used bearings to remove old lubricant or debris. Thoroughly wash new bearings to remove the packaged grease, which may be incompatible with the grease applied. Dry bearings before packing with fresh grease.

Do not apply any lubrication to cadmium plated current path parts of special cadmium plated breakers.

### CAUTION

*When mechanism cleaning and re-lubrication is required, do not use solvents. Solvents introduce foreign debris into bearings, strip remaining lubricant from working surfaces, and can leave a binding residue. A mechanism with contaminated grease should be completely refurbished.*

### CAUTION

*DO NOT apply light machine oil or thin spray lubricants to lubricate any mechanism part.*

### CAUTION

*DO NOT attempt to re-lubricate the spring charging motor gearbox; it is sealed and should not require re-packing.*

### CAUTION

*DO NOT lubricate, clean, or spray the magnetic latch device with any substance.*

### Structural Insulation

Insulated parts should be checked for damage. Glass-polyester insulation may be cleaned with a clean cloth and denatured alcohol. While cleaning parts, avoid getting alcohol on points of lubrication. Test the

insulation dielectric as described in the *Insulation Withstand* section.

### Setting Adjustments

The breaker control devices utilize self-locking hardware that should not be routinely adjusted; otherwise, the locking feature becomes increasingly compromised.

Device settings are factory established and will not normally need subsequent readjustment unless the device is malfunctioning, removed, replaced, or indirectly affected by other device adjustments.

Several device settings work dependently on the latch and tripper bar. Should the latch engagement or tripper bar travel be adjusted, reestablish the setting of all affected devices.

### Contact Structure

Contact structure adjustment is a routine maintenance item and must be checked at every service interval. Contact adjustment is an iterative process of both pressure and simultaneous-make adjustments. The measurement may vary slightly each time that it is checked. Avoid undue "searching" which will wear the locking material of the adjustment stud. If an adjusting stud appears not to hold the contact pressure setting while making operational checks, then apply "blue" Loctite to the threads and consider replacing the part. Adjust pressure accordingly by turning the adjustment screw in the direction shown in Figure 6d.

Perform any contact structure adjustment as described in the *Slow-close Procedure* section.

### CAUTION

*The contacts are set on a closed breaker. Keep clear of potential moving parts should you inadvertently trip the breaker during adjustment.*

### 225 Ampere Frames

1. Same as step #1 for the 600 and 800 ampere frames.
2. Contact pressure is established by adjusting the stud for 1-3/4"  $\pm$  1/32" open-air gap as dimensioned at **A** in Figure 6a. Any adjustment of contact pressure must be followed by the simultaneous-make adjustment in step #3.
3. Same as step #3 for the 600 and 800 ampere frames.

If for any reason the contact structure is removed from the breaker, upon assembly, reapply clean NO-OX-ID "A-Special" to the ends of the contact bushing. Torque the hinge-joint nut between 15 and 25 lb-ft to maintain the continuous current rating of the circuit breaker.

### 600 and 800 Ampere Frames

(K-600, K-800, K-600S, K-800S, and K-800M)

1. The hex portion of the adjustment stud must be centered within 1/16" between the yoke and the pushrod insulator.

2. Contact pressure is established on a closed breaker with the adjustment stud for a 5/64" to 3/32" gap at **A** in the upper window of the contact carrier on each side as shown in Figure 6b. The most proficient way is to slide 5/64" and 3/32" diameter wires (go and no-go) bent at 90° up and down in the slot. Close the circuit breaker. Using the side with the larger gap, set the gap to accept the "Go" gauge but reject the "No-Go" gauge. Open and again slow-close the circuit breaker to recheck the pressure. Follow each adjustment of contact pressure by a making adjustment in step #3. After completing step #3, the adjusted poles may have a pressure setting greater than 3/32"; this results in more contact pressure on these poles, which is acceptable.

3. Slow-close the contact structure until the arcing contacts of one pole just touch. At this point, the arcing contacts of the other two poles should be within 1/32" of touching (same idea for a two pole breaker). If not within 1/32", then turn the adjustment stud of these two poles in the direction to increase pressure until all three poles touch within 1/32". Should the pressure be too excessive to allow the breaker to latch closed, return to the first making pole, decrease its pressure by 1/8 revolution (CW), and recheck the simultaneous-make. Repeat in increments of about 1/8 revolution for no more than 1/2 revolution of the adjusting stud on the first make pole, until the breaker latches closed.

If for any reason the contact structure is removed from the breaker, upon assembly, reapply clean NO-OX-ID "A-Special" to the ends of the contact bushing. Torque

the nut of the hinge joint between 15 and 25 lb-ft to maintain the continuous current rating of the circuit breaker.

#### 1600 A and 2000 A Circuit Breakers

(K-1600, K2000, K1600S, K2000S, K-1600M, and K2000M)

The main contact adjustment is to be made with the breaker in the latched closed position. Contact pressure is established by turning the adjustment stud until a go-gauge will just fit the space **A** at the rear of the moving main contacts as illustrated in Figure 6c. Set at 3/4" [+0", -1/64"].

After making this adjustment in contact pressure, open the circuit breaker, re-close the circuit breaker normally, and recheck the gap **A**. Readjust if necessary.

Open the circuit breaker and slow-close the contacts until the arcing contacts of one pole just touch. The remaining poles should then be adjusted for simultaneous-make by advancing the adjustment stud until all poles touch within 1/32" of one another. The contact pressure will increase on the adjusted poles as evidenced by a pressure setting of less than 3/4"; this results in more contact pressure on these poles, which is acceptable.

For 2000 ampere breakers (tulip style primary disconnects), if the primary disconnect stud is removed, retorquing the stud to 110 lb-ft.

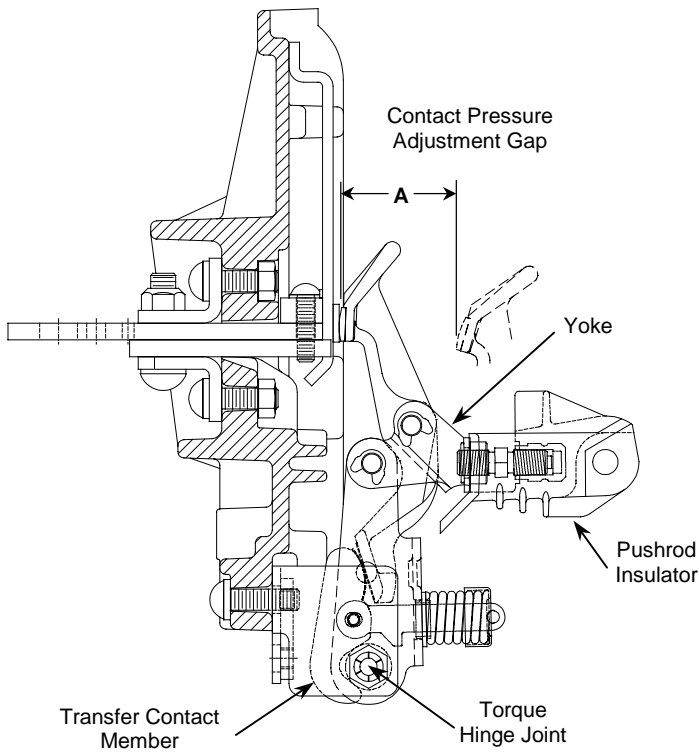

**Figure 6a. 225 Ampere Contact Structure.** Left-hand view drawn in the closed position. Similar structure to Figure 6b, except the moving arc contact member serves as the moving main contact member. Notice that the upper terminal is comprised of one stud. Contact pressure is established by open-air gap **A**.

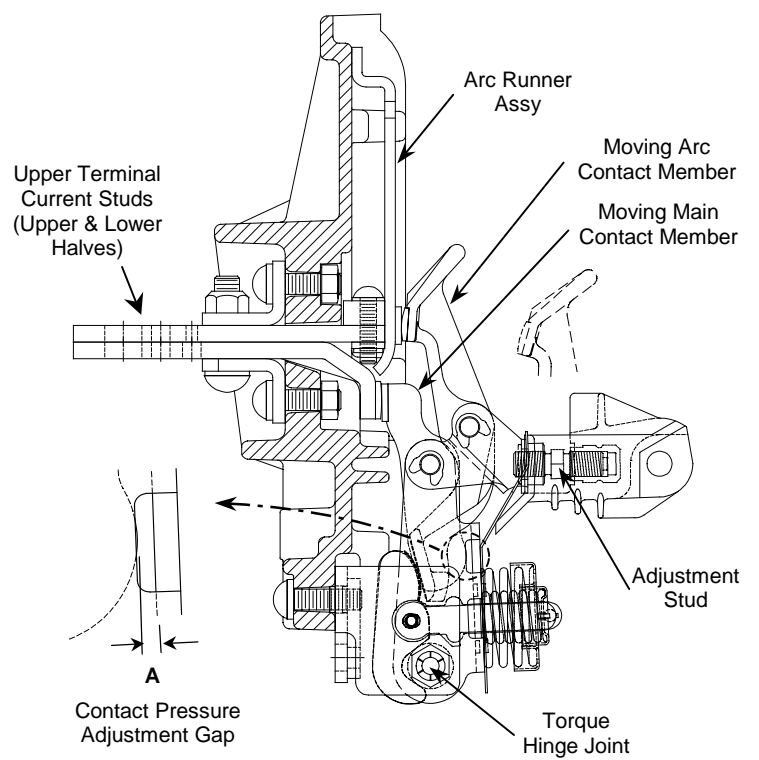

**Figure 6b. 600 and 800 Ampere Contact Structure.** Left-hand view, drawn in the closed position. Contact pressure is established by gap **A** on a closed breaker.

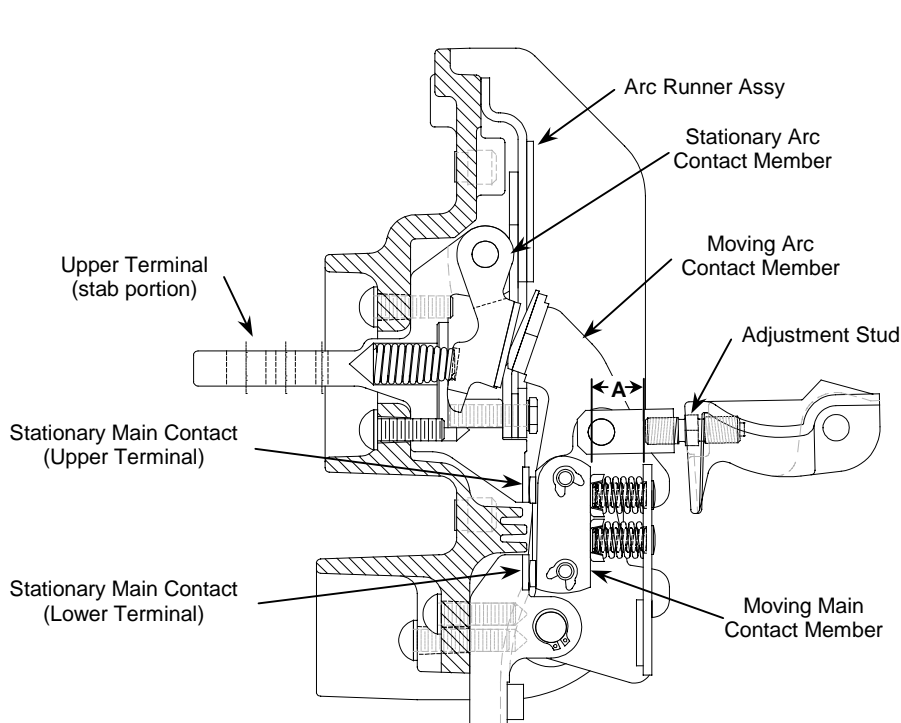

**Figure 6c. 1600 and 2000 Ampere Contact Structure (except 2000 A Upper Terminal).** Left-hand view drawn in the closed position. Contact pressure is established with gap **A** on a closed breaker.

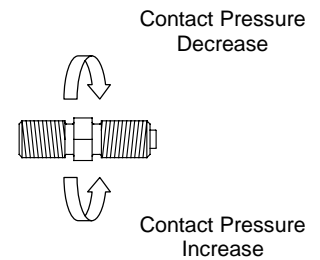

**Figure 6d. Contact Pressure Adjustment.** Viewed from left side as illustrated in each structure.

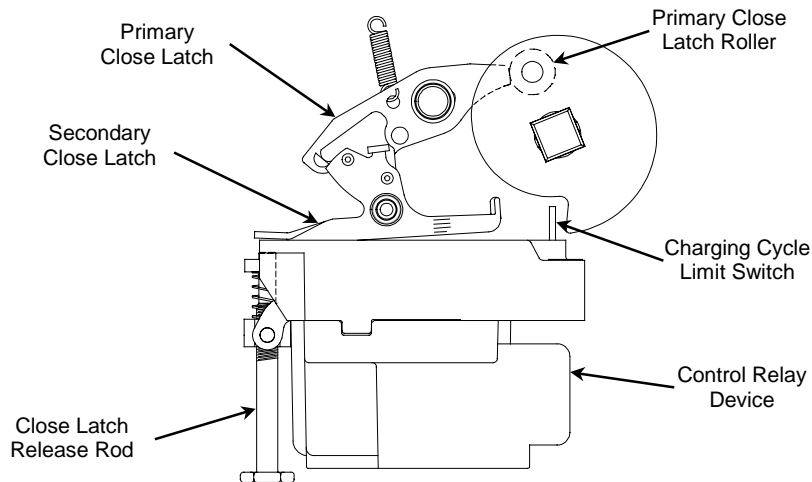

**Figure 7. Close Latching System on EO Mechanisms. Left-hand view. Shown in the charged and latched position.**

### **Control Relay Device**

The control relay device is adjusted before leaving the factory. It is recommended that no attempt be made to adjust the internal relays and contacts of this device in the field. If replacement of the control device is required, adjust the close latch release rod travel after installing the new control relay device.

### **Close Latch Release Rod Travel**

The release rod is externally integrated on the left side of the control relay device. Make this adjustment whenever the close latches are replaced or the control relay device is replaced.

1. Reverse the release rod CCW (viewed from the striking head) and check that the circuit breaker will not close by attempting to close it electrically or manually by pushing the release rod through its full range of travel.
2. Charge the closing springs. Push up and hold the release rod at full travel. Advance the release rod CW until the circuit breaker closes.
3. From the closing threshold, advance the release rod an additional 1-1/2 revolutions CW.

To ensure a properly matched style of latches, ABB recommends replacing both the secondary and primary close latches as a set.

### **Trip Latch Engagement**

This adjustment affects the setting for the tripper bar, shunt trip device, magnetic latch device, OD devices, and the undervoltage device. Do not adjust the trip latch setting unless the mechanism malfunctions or is refurbished. The screws for adjusting the trip latch engagement ("bite") and the tripper bar travel are located on the right-hand mechanism housing. Access

the screws from the top of the breaker. To adjust the latch engagement, proceed as follows:

### **WARNING**

*This adjustment is made on a closed breaker. Keep hands and tools clear of moving parts while setting the device. Furthermore, the breaker may trip before the point anticipated.*

1. If the circuit breaker will not latch closed, reverse the inner adjusting screw CCW enough to ensure latch engagement.
2. Close the circuit breaker.
3. Slowly advance the adjusting screw CW until the trip latches release and trip the breaker open.
4. Reverse the adjusting screw 2 revolutions CCW further to establish sufficient trip latch engagement.

### **Tripper Bar Travel**

This adjustment sets an appropriate amount of play between the tripper bar and the secondary trip latch. Without this play, incidental shock vibration may subject the breaker to nuisance tripping. The adjusting screw for the tripper bar engagement is located adjacent to the latch engagement adjusting screw.

Proceed as follows to adjust the tripper bar latch engagement:

1. Reverse the adjusting screw (CCW) to assure excessive tripper bar travel.
2. Close the circuit breaker.
3. Slowly advance the adjusting screw CW until the latch just releases, tripping the circuit breaker open.
4. Reverse the adjusting screw 3-1/2 revolutions CCW.

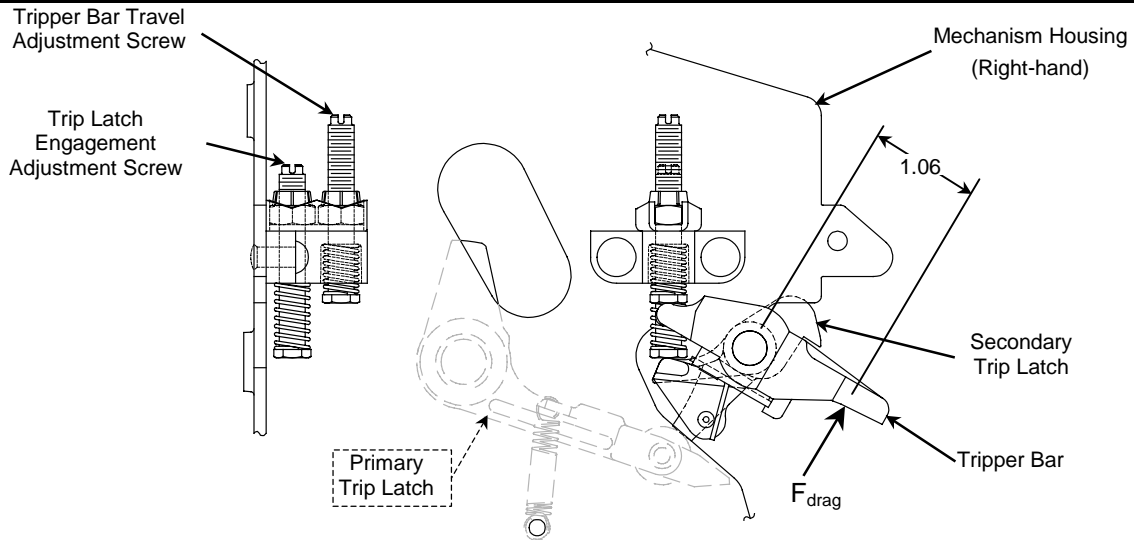

**Figure 8. Trip Latch Adjustments.** Right-hand view shown. Drawn in the latched closed position.

**Shunt Trip Device**

Adjustment establishes sufficient range of trip rod travel and impact energy to actuate the trip latches.

Perform this adjustment only when the device has malfunctioned, been removed, or been replaced. This adjustment must be made after any adjustment to the trip latch.

**WARNING**  
*This adjustment is made on a closed breaker. Keep hands and tools clear of moving parts while setting the device. The breaker may trip before the point anticipated.*

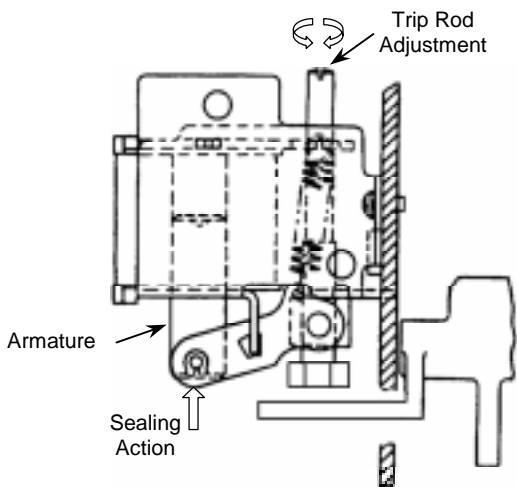

**Figure 9. Shunt Trip Device.** Viewed from front as mounted on the left-hand mechanism housing. Device is typical of all breakers, except for small frames with an electronic trip system.

K-225 through K-2000, K1600S, K-2000S, K-1600M, and K-2000M

(All large frame breakers and small frame breakers without electronic trip.)

1. Locate the device, illustrated in Figure 9, on the left side of the mechanism. On an open breaker, fully reverse (CCW) the adjustment of the trip rod.
2. Close the circuit breaker.
3. Seal the coil armature by pushing it into the device as far as it will travel. If the breaker trips, advance the trip rod CW 2-1/2 revolutions.
4. If the breaker did not trip when the armature was sealed in step #3, hold the sealed-in position and advance the trip rod CW until the breaker trips open. From the trip threshold, establish over-travel by advancing the trip rod CW an additional 3 revolutions.

K-600S, K-800S, and K-800M

(All small frame breakers with electronic trip.)

1. Locate the device, illustrated in Figure 10, on the left side of the mechanism. On an open breaker, fully reverse (CCW as viewed from the hex head) the adjustment of the trip rod, or at least enough that a closed breaker will not trip with the device armature sealed.
2. Close the circuit breaker.
3. Seal the armature by pushing it into the device as far as it will travel. Be aware that the breaker may trip if the trip rod in step #1 was not reversed enough. Hold the sealed-in position and advance the trip rod CW until the breaker trips open. This is the trip threshold.
4. From the trip threshold, establish over-travel by advancing the trip rod one additional revolution CW.

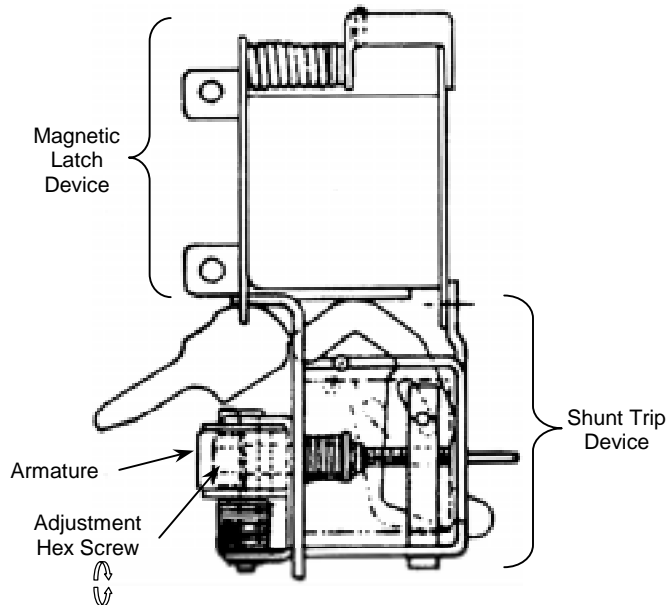

**Figure 10. Shunt and Magnetic Latch Device Assemblies.** Left-hand view shown. These integrated devices are typical of small frame breakers with an electronic trip system. The magnetic latch does not have an adjustment.

#### ***Magnetic Latch Device***

K-600S, K-800S, & K-800M

This device mounts together with the shunt trip device as illustrated in Figure 10. Find the device mounted to the left-hand mechanism housing. The device does not have an adjustment.

K-1600S, K2000S, K-1600M, and K-2000M

This device, illustrated in Figure 11, mounts to the front mechanism cover in the upper right-hand area. Perform this adjustment if the device was removed or replaced. Perform this adjustment whenever either the trip latch or tripper bar was adjusted.

#### **WARNING**

***This adjustment is made on a closed breaker. Keep hands and tools clear of moving parts while setting the device; the breaker may trip before the point anticipated.***

1. Locate the magnetic latch trip lever and the tripper bar.
2. After closing the circuit breaker, gently push up on the tripper bar until resistance is encountered. Stop pushing immediately.
3. With the tripper bar pushed up, measure the distance between the adjusting screw and tripper bar. The pre-travel gap should be 1/4" to 5/16".
4. Adjust the adjusting screw, if necessary, to re-establish the tripper bar pre-travel.

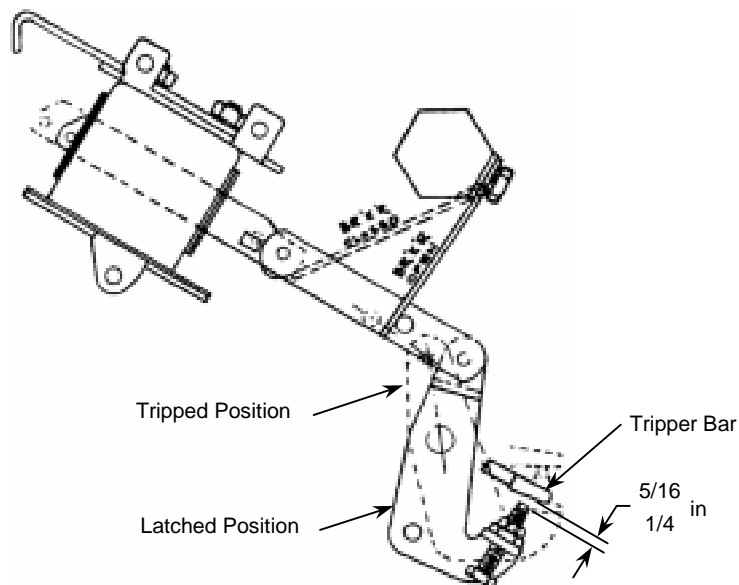

**Figure 11. Magnetic Latch System.** Left-hand view shown. System is typical of large frame breakers with an electronic trip system (shown with a type "S" trip latch device).

#### ***Electro-Mechanical Overcurrent Trip Device (OD)***

##### Pickup Setting Adjustments

Pickup settings are selected by turning adjustment screws on the bottom of the device until the moving indicator aligns with the desired pickup point scribe-mark.

##### Long-time Delay Band Adjustments

Turn the delay adjustment screw until the top of the indicator matches the desired delay line. Push the armature toward the magnet, allowing time for oil in the dashpot to be displaced. Release the armature, allowing it to reset. Check that the long-time indicator still matches the calibrated pickup marking. Readjust if required and recheck by again pushing the armature and allowing it to reset.

**NOTE:** OD-3 has only one long-time delay setting (wide range) which is factory set and therefore adjustment is not required.

##### Short-Time Delay Adjustment

Move the lever toward the left of the circuit breaker so that the step pin can be moved to the desired short-time delay pin hole. Make certain the step pin drops into the pinhole.

##### Armature Trip Travel Adjustment

#### **WARNING**

***Keep clear of all moving parts. The circuit breaker will trip to the "OPEN" position while checking or adjusting the armature trip travel.***

The overcurrent trip device trip travel is set at the factory; however, if trip travel readjustment is required due to replacement of the device or affected parts, readjust as follows:

1. Reverse the two trip adjusting screws CCW until the screws engage the nut by approximately two revolutions.
2. Charge the closing springs and close the circuit breaker.
3. Push up on the long-time armature (wide armature) and seat it firmly against the magnet. When pushing against the long-time armature, allow time for oil in the dashpot to displace. Keeping the armature seated against the magnet, advance the screw CW until the circuit breaker trips. Advance the screw one additional revolution CW.

### CAUTION

*During this adjustment operation, hold the armature firmly against the magnet, but do not exert excessive force that will result in incorrect adjustment due to distortion.*

4. Charge the closing springs and close the circuit breaker. Push up on the thin armature and adjust the screw using the same procedure as in step #3.
5. Readjust the trip travel for the other pole(s) as in steps #1 through #4.

See Table B1 of Appendix B for applicable time-current curves and reference to complete device instruction and testing. Table A4 of Appendix A lists all nameplate ratings available for each standard type of OD device.

#### **Solid-state Overcurrent Trip Device**

No device adjustments are made on the Power Shield trip device. Confirm settings and make certain that the selector plugs are seated completely. Coordination will be affected if a plug taps intermittently or is missing since the device will default to the minimum setting available.

### WARNING

*Do not disconnect the harness from the trip unit on a closed breaker in service. Current transformers on the breaker poles power the trip unit. Disconnecting the harness will produce high voltage arcing due to the resulting open circuit condition of the sensors. The breaker must be open before connecting or disconnecting the trip unit harness, or otherwise de-energized.*

See Table B2 of Appendix B for applicable time-current curves and reference to complete device instruction and testing.

#### **Microelectronic Overcurrent Trip Device**

No device adjustments are made on MPS, MPS-C, or MPSC-2000 devices. Trip settings are set on the unit and only need confirmation.

See Tables B3 and B4 of Appendix B for applicable time-current curves and reference to complete device instruction and testing.

### WARNING

*Do not disconnect the harness from the trip unit on an energized breaker. Current transformers on the breaker poles power the trip unit. Disconnecting the harness will produce high voltage arcing due to the resulting open-circuit condition of the sensors. The breaker must be open before connecting or disconnecting the trip unit harness, or otherwise de-energized.*

## Operational Checks

#### **Draw-out Shutter and Racking**

Confirm that the interlocked shutter will not open for handle insertion when the breaker is closed, regardless of draw-out position. On an open breaker, rack the breaker into each of the draw-out positions and confirm that the shutter closes when the handle is removed. Notice that the shutter does not close between positions; the interlocking forces the mechanism to be trip-free.

#### **Auto Spring Discharge**

Trip the breaker open. Place the breaker in the TEST position. Charge the closing springs but do not close the breaker. Rack the charged breaker into the DISCONNECTED position. The springs should discharge just before reaching DISCONNECTED.

#### **Electrical Charging, Closing, and Opening**

Confirm functional circuit breaker operation by sequencing the breaker through the charge, close, and open cycles. Test both electrical and manual controls. Verify local and remote operation.

#### **Trip-free Mechanism**

Initiate breaker closure while maintaining a trip signal (or depressing the local trip button). The mechanism should trip-free rather than latch closed.

#### **Anti-pump Circuit (EO)**

This check verifies function of the lockout relay coil. Test the anti-pump as follows:

1. Charge the breaker electrically.
2. Electrically close the breaker and maintain the close signal.
3. While still maintaining the close signal, trip the breaker open. The motor will recharge the closing springs.

If the anti-pump lockout relay is functioning, the breaker will not re-close (after the motor recharges the closing springs) until the original close is released and reissued.

#### **Magnetic Latch Release**

Verify device operation. The simplest way to test the device is with secondary current injection to the trip device from a test set or with primary current injection through the breaker itself.

### **Trip Latch Drag Force**

#### **CAUTION**

*This check is made on a closed breaker that is subsequently tripped open. Keep clear of moving parts.*

This measurement confirms the ability of the trip system to trip the primary latching. Measure the drag force by applying a spring scale on the tripper bar as indicated in Figure 8.

Electromechanical trip devices actuate the tripper bar directly with the tripping element armature upon pickup. Electronic trip systems employ a magnetic latch to strike the tripper bar. The higher kinetic energy of a magnetic latch device overcomes a higher drag load than does an armature of an OD device; consequently, the acceptable drag loads differ. On electromechanical trip devices, the drag force should not exceed 29 ounces. On circuit breakers with electronic trip systems, the drag force should not exceed 50 ounces. If the drag force exceeds these allowable loadings and no mechanical binding is found, then the mechanism is in need of refurbishment. Continued use risks a “hang-fire” condition during an automatic trip event.

#### **Current Path Resistance**

Measure pole resistance between the upper and lower terminals behind the breaker, exclusive of the primary disconnects. After breaker maintenance and pre-operative checks, compare the renewed values to previous service records and Table A6 of Appendix A. Readings that exceed the maximum allowable values suggest improper contact pressure or worn contact structure. This may generate heating beyond the thermal design limit of the circuit breaker if loaded to the continuous current rating.

The pole resistance of OD equipped breakers includes the additional resistance of the OD device coil assembly, which is in series with the current path. Reference Table A5 for coil assembly resistance.

#### **Insulation Withstand**

Remove the circuit breaker from its enclosure and conduct a Withstand-Voltage Test to prove the dielectric integrity of the circuit breaker.

According to breaker condition, apply the applicable test voltage between the primary circuit, secondary circuit, and grounded parts as indicated in Table A1 of Appendix A. Establish test voltage within 5 to 10 seconds and maintain for 1 minute. Flashover defines a failed test.

Testing a Power Shield trip unit:

1. Connect all sixteen terminals of the Power Shield trip unit together.
2. Apply 500 V<sub>AC</sub> between the sixteen terminals and metal parts normally grounded.

ABB does not recommend withstand testing of the MPS, MPS-C, or MPSC-2000 trip units.

#### **Points of Test Voltage Application:**

On an OPEN circuit breaker, apply primary-circuit test voltage:

1. Between the primary circuit, including both the upper and lower terminals, and ground all metal parts that are normally grounded. All poles of the primary circuit may be jumpered together for one test. The Ground Disconnect shown in Figure 1d or an unpainted section of the metal frame may be used for ground.
2. Between the primary and secondary (control) circuit.
3. Between the upper and lower terminals of the primary circuit. Rather than testing each permutation, jumper the upper terminals together, then separately jumper the lower terminals together. Conduct a single test between the upper and lower terminals.

Note: For convenience, connecting the secondary circuit to the grounded parts can combine tests 1 and 2 above. Should a breakdown occur, perform both steps individually to determine which mode had failed.

On a CLOSED circuit breaker, apply primary-circuit test voltage:

1. Between the primary circuit and ground all parts that are normally grounded.
2. Between the primary and secondary (control) circuit.
3. Between the primary terminals of adjacent phases.

On an OPEN or CLOSED circuit breaker, apply secondary-circuit test voltage between the secondary circuit and ground all parts that are normally grounded.

#### **CAUTION**

*The charging motor is rated at a lower dielectric withstand-voltage than the control circuit. Before testing the control circuit, isolate the motor by turning the motor disconnect switch OFF. Test the motor specifically by testing the control circuit again, but with the motor disconnect switch turned ON and at the lower voltage specified for the motor.*

#### **Renewal Parts**

To minimize interrupted service, ABB recommends stocking common replacement items. Part assemblies are suggested for reliable and timely interchange. An abbreviated list of common replacement parts is listed in Appendix C.

A Renewal Parts Bulletin is available from the nearest ABB District Sales Office. Verify the part number and proper application prior to ordering.



## Appendix A

### General Circuit Breaker Information

**Table A1 – Test Voltages for AC Dielectric Withstand-Voltage Test**

Circuit Breaker Condition	Primary Circuit	Secondary (Control) Circuit	
		Motor Disconnected	Motor Connected
	[V <sub>AC</sub> ]	[V <sub>AC</sub> ]	[V <sub>AC</sub> ]
<b>New</b>	2200	1500	1000
<b>In-Service</b> (75% of New)	1500	1125	750
<b>After Short-Circuit</b> (60% of New)	1320	900	600

**Table A2 - Control Circuit Requirements at Standard Voltages**

Nominal Control Voltage	Charging Circuit		Close Circuit			Shunt Trip Circuit		Recommended Control Fuse Rating
	Average Motor Current		Operating Range	Control Relay Coil Current		Operating Range	Coil Current	
	Ametek	Ryobi		Anti-Pump	Release			
[V @ f]	[A]	[A]	[V]	[A]	[A]	[V]	[A]	[A]
120 V <sub>AC</sub> @ 50/60 Hz	10	4	104-127	0.15	1.5	104-127	6.5	10
240 V <sub>AC</sub> @ 50/60 Hz	5	2	208-254	0.075	0.75	208-254	1.15	10
48 V <sub>DC</sub>	25	10	38-56	0.11	1.26	28-56	3.14	15
125 V <sub>DC</sub>	10	4	100-140	0.054	0.69	70-140	1.3	10
250 V <sub>DC</sub>	5	2	200-280	0.026	0.38	140-280	0.65	10

**Table A3 - Undervoltage Trip Device Operating Conditions**

Reference IB 6705 for Field Installation Instructions

Nominal Control Voltage	Current at Nominal Voltage	Maximum Pickup Voltage (80% of Nominal)	Dropout Voltage Range (30-60% of Nominal)
[V @ f]	[A]	[V]	[V]
120 V <sub>AC</sub> @ 50/60 Hz	0.5	96	36-72
240 V <sub>AC</sub> @ 50/60 Hz	0.2	192	72-144
480 V <sub>AC</sub> @ 50/60 Hz	0.1	384	144-288
48 V <sub>DC</sub>	0.3	38	15-29
125 V <sub>DC</sub>	0.2	100	38-75
250 V <sub>DC</sub>	0.1	200	75-150

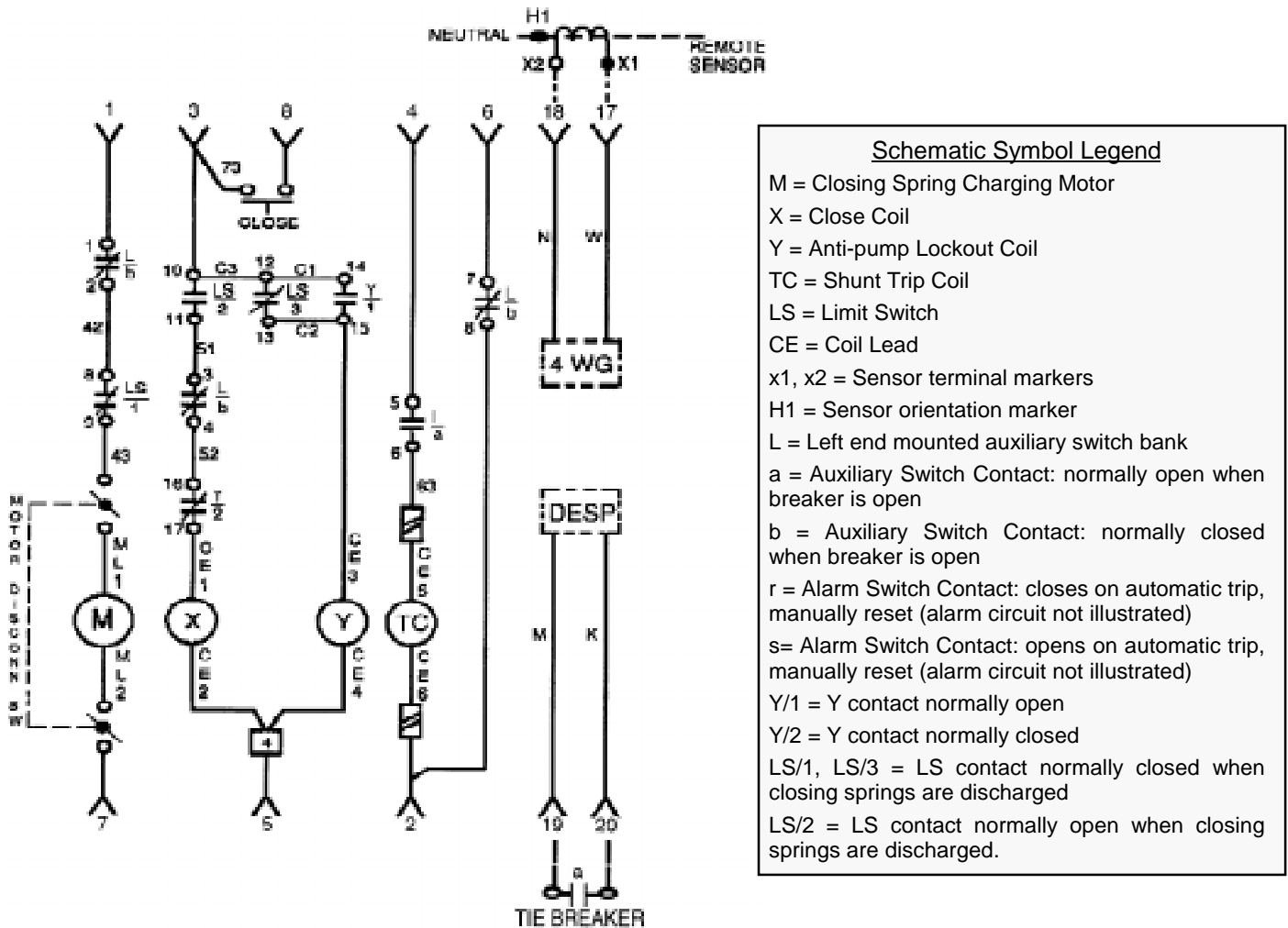

**Figure A1. Schematic of a Basic Control Circuit for an EO circuit breaker.** Illustrated for a breaker in the OPEN and SPRINGS DISCHARGED state. The basic circuit includes a closing spring charging motor, local electric push button close, control relay device (close and lockout coils), and a shunt trip device. Also shown: optional four wire ground and double-ended substation applications.

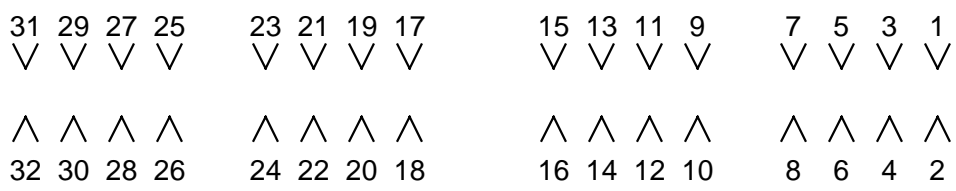

**Figure A2. Arrangement of Secondary Disconnects and Contact Identification.** Viewed from the rear of the circuit breaker. Depending upon the installed options, a circuit breaker may be equipped with all four pair of secondary disconnects as illustrated.

**Table A4 - Nameplate Ratings Available for Standard OD Devices**

(Calibrated pickup points are based on nameplate rating.)

Nameplate Rating	Standard Electromechanical Overcurrent Device					
	OD-3		OD-4	OD-5	OD-6	OD-7
[A]	AC	DC	AC & DC	AC & DC		
15						✓
20	✓	✓				✓
30						✓
40	✓	✓				✓
50						✓
70	✓	✓				✓
90			✓			✓
100			✓			✓
125	✓	✓	✓			✓
150			✓			✓
175			✓			✓
200			✓			✓
225	✓	✓	✓			✓
250			✓			✓
300			✓			✓
350			✓			✓
400	✓	✓	✓			✓
450			✓			✓
500		✓	✓			✓
600	✓	✓	✓			✓
800	✓	✓	✓			✓
1000		✓	✓			✓
1200			✓			✓
1600	✓	✓	✓			✓
2000	✓	✓	✓			✓
2500		✓				

Table A5 - OD Coil Assembly Resistance Based on Device Rating and Circuit Breaker Frame Size

Grouped ratings all use the same coil assembly.

Standard OD Device Ratings Available by Circuit Breaker Frame Size					OD Coil Assembly		
K-225	K-600	K-800	K-1600	K-2000	Turns	Allowable Resistance <sup>a,b</sup>	Maximum Test Current
[A]	[A]	[A]	[A]	[A]		$\mu\Omega$	[A]
20, 15					68		
40, 30	40, 30				39	7000	5
70, 50	70, 50				18	1850	10
125, 100, 90	125, 100, 90	125, 100, 90			11	600	20
225, 200, 175, 150	225, 200, 175, 150	225, 200, 175, 150	225, 200, 175, 150		6	212	40
	250	250			4		
	450 <sup>c</sup> , 400, 350, 300, 250 <sup>d</sup>	450 <sup>c</sup> , 400, 350, 300, 250 <sup>d</sup>			3	50	100
	600, 500	800, 600, 500			2	30	200
			250	250	4		
			450 <sup>c</sup> , 400, 350, 300, 250 <sup>d</sup>	450 <sup>c</sup> , 400, 350, 300, 250 <sup>d</sup>	3	50	100
			800, 600, 500	800, 600, 500	2	30	200
			1600, 1200, 1000	1600, 1200, 1000	1	7.5	200
				2500, 2000	1	5.0	200

<sup>a</sup> Maximum allowable resistance for Ag plated devices that are fully loaded at the highest current rating available for all ratings of the same coil assembly.<sup>b</sup> Double the allowable values for breakers with a Cd plated current path.<sup>c</sup> Rating is not available on OD-3.<sup>d</sup> OD-3 only. All other standard devices use a 4-turn coil for this rating.

**Table A6 - Maximum Allowable Current Path Resistance for K-Line Circuit Breakers as Non-Automatic or With Solid-state or Microelectronic Trip Systems**

Circuit breakers with an OD trip system must add the applicable coil assembly resistance (Table A5) to the non-OD resistance in Table A6 below.

Frame Size	Maximum Allowable Resistance <sup>a,b</sup>		Maximum Test Current <sup>c</sup>
	New or Restored	As-found	
[A]	[ $\mu\Omega$ ]	[ $\mu\Omega$ ]	[A]
225	120	200	100
600	63	100	200
800	63	100	200
1600	28	50	200
2000	24	50	200

<sup>a</sup> Measure between upper and lower terminals exclusive of the primary disconnects.

<sup>b</sup> Double the allowable values for breakers with a Cd plated current path.

<sup>c</sup> When testing OD circuit breakers, do not inject a test current through the current path above the maximum test current for the coil assembly shown in Table A5.

## Appendix B

### Overcurrent Trip Devices

**Table B1 - Standard Electro-Mechanical Overcurrent Trip Devices**

Reference IB 8203 for OD Operating Instructions and Testing Procedure

Overcurrent Device Type	Designation	Device Elements			Time-Current Curve	
		Range of Pickup as a Percentage of Device's Coil Rating			AC	DC <sup>a</sup>
		LT	ST	INST		
OD-3	General Purpose <sup>b</sup>	50-125		500-1500	TD-6693	TD-9403
OD-4	Dual Selective	80-160	400-1000		TD-6694	TD-9034
OD-5	Triple Selective	80-160	400-1000	500-1500	TD-6695	TD-9402
OD-6	Dual selective	80-160		500-1500	TD-6695	TD-6695
OD-7	High INST			500-1500	TD-6695	TD-6695
OD-8	Special Low INST			80-250	TD-6695	TD-6695

<sup>a</sup> DC devices may be tested with AC current when using a DC equivalent of  $0.95AC_{RMS}$ . If measuring device reads  $AC_{peak}$ , then obtain an  $AC_{RMS}$  reading by dividing  $AC_{peak}$  by  $\sqrt{2}$ .

<sup>b</sup> The OD-3 long-time delay element has one wide range time delay band. All other OD devices with LT delay have three time-delay bands.

**Table B2 - Standard Solid-state Trip Devices**

Reference IB 6.1.2.7-4 for Power Shield Operating Instructions and Testing Procedure

Device Type	Device Elements				Time-Current Curve	
	LT	ST	INST	GND	Device in Red <sup>a</sup> Case	Device in Gray Case
SS-3	✓		✓		TD-6966	TD-9001
SS-4	✓	✓			TD-6967	TD-9002
SS-5	✓	✓	✓		TD-6967	TD-9002
SS-13	✓		✓		N/A	TD-9003
SS-14	✓	✓			N/A	TD-9004
SS-15	✓	✓	✓		N/A	TD-9004
SS-nG <sup>b</sup>				✓	TD-6968	TD-9005

<sup>a</sup> Device in red case was a previous manufacture (Prior 1974)

<sup>b</sup> Ground type devices add a ground trip element to the "n" type functions.

SS-13, SS-14, & SS-15 have longer LT delays for special coordination applications.

**Table B3 - Standard Microelectronic Trip Devices**

Reference IB 6.1.1.7-4 for MPS Operating Instructions and Testing Procedure

Device Type	Device Elements				Time-Current Curve
	LT	ST	INST	GND	
MPS-3	✓		✓		TD-9601
MPS-4	✓	✓ ✓			TD-9602 [ST I <sup>2</sup> t OUT] TD-9604 [ST I <sup>2</sup> t IN]
MPS-5	✓	✓ ✓	✓		TD-9602 [ST I <sup>2</sup> t OUT] TD-9604 [ST I <sup>2</sup> t IN]
MPS-nG <sup>a</sup>				✓	TD-9603

<sup>a</sup> Ground type devices add a ground trip element to the “n” type functions.

**Table B4 – Standard Microelectronic Trip Devices with Communication**

Reference IB 6.1.1.7-5 for MPS-C Operating Instructions and Testing Procedure

Reference IB 6.1.2.8-1 for MPS-C 2000 Operating Instructions and Testing Procedure

Reference IB 6.1.1.7-6 for BTSB Operating Instructions and Testing Procedure

Overcurrent Device Type	Device Elements				Time-Current Curve
	LT	ST	INST	GND	
MPS-C-3	✓		✓		TD-9651
MPS-C-4	✓	✓ ✓			TD-9651 [ST I <sup>2</sup> t OUT] TD-9653 [ST I <sup>2</sup> t IN]
MPS-C-5	✓	✓ ✓	✓		TD-9651 [ST I <sup>2</sup> t OUT] TD-9653 [ST I <sup>2</sup> t IN]
MPS-C-nG <sup>a</sup>				✓	TD-9652
MPS-C 2000 <sup>b</sup>	✓	✓ ✓	✓	✓	TD-9651 [ST I <sup>2</sup> t OUT] TD-9653 [ST I <sup>2</sup> t IN] TD-9652

<sup>a</sup> Ground type devices add a ground trip element to the “n” type functions.

<sup>b</sup> The I<sup>2</sup>T delay feature for ST or INST, and GND is defeatable.

## Appendix C

## Abbreviated Renewal Parts List

## Maintenance Items:

<b>Maintenance Accessory Kit (Universal):</b>	<b>709770-T01</b>
Lifting Yoke	709770-T05
Racking Handle	711706-K03
Maintenance Handle (EO)	716664-T01
<b>Greases:</b>	
NO-OX-ID "A-Special"	713222-A00 (1 pint can)
Anderol 757 Synthetic	712994-C00 (1 lb can)

## Charging and Closing Items:

Standard Control Voltage	Spring Charging Motor		Control Relay Device		
	Ryobi	Remanufactured Ametek	Close Coil	Lockout Coil	Complete Relay Device
120 V <sub>AC</sub> @ 50/60 Hz	18006-P10	716799-A01	702250-K03	702250-K05	708392-T09
240 V <sub>AC</sub> @ 50/60 Hz	18006-P20	716799-A02	702250-K09	702250-K06	708392-T10
48 V <sub>DC</sub>	18006-P30	716799-A03	702250-K08	702250-K04	708392-T06
125 V <sub>DC</sub>	18006-P10	716799-A01	702250-K16	702250-K01	708392-T07
250 V <sub>DC</sub>	18006-P20	716799-A02	702250-K07	702250-K02	708392-T08

## Current Path Items:

Item:	225	600/800	1600	2000
Primary Disconnects	706777-T01	706777-T03	706777-T11	706777-T15
Secondary Disconnects	703153-K01 (4 Contacts)			
Auxiliary Switch Bank	700034-K01 (4 Contacts), 700038-K01 (8 Contacts)			
Upper Base Molding and Stationary Contact Assembly	706784-T01	706784-T03	706784-T05	706784-T06
Moving Contact Assembly	706783-T01	706783-T02	706783-T03	706783-T07
Contact Pressure Adjustment Stud	701501-B00			
Interphase Barrier (between adjacent poles)	701531-A00			N/A
Insulation Shield (arcing chamber - non-auto and OD trip)	708290-A00			N/A
Insulation Shield (arcing chamber - electronic trip)	710549-A00			N/A
Insulation Shield ("bucket" style - non-auto and OD trip)	N/A			707110-A00
Insulation Shield ("bucket" style - electronic trip)	N/A			716308-A00
Arc Chute	706775-T12			706775-T13
Arc Chute Retainer	701496-A00			701543-A00



---

**Notes**



ABB Power T&D Company, Inc.  
Distribution Systems Division  
P.O. Box 100524  
Florence, S.C. 29501-0524  
Phone: (843) 665-4144  
Fax: (843) 667-5109

Issue "A" @ 7-99

Marketing and Sales: (800) 338-1585  
Post Order Service and Warranty: (800) 634-7643  
Component Sales: (800) 929-7947  
Kirk<sup>®</sup> Key Interlock: (800) 438-2442  
Email: [dsinfo@us.abb.com](mailto:dsinfo@us.abb.com)

ABB Corporate Help Desk: (800) 626-4999  
US Corp. Web Site: [www.abb.com/usa/](http://www.abb.com/usa/)