

For separate brake supply.
 Para freno conectado independiente.

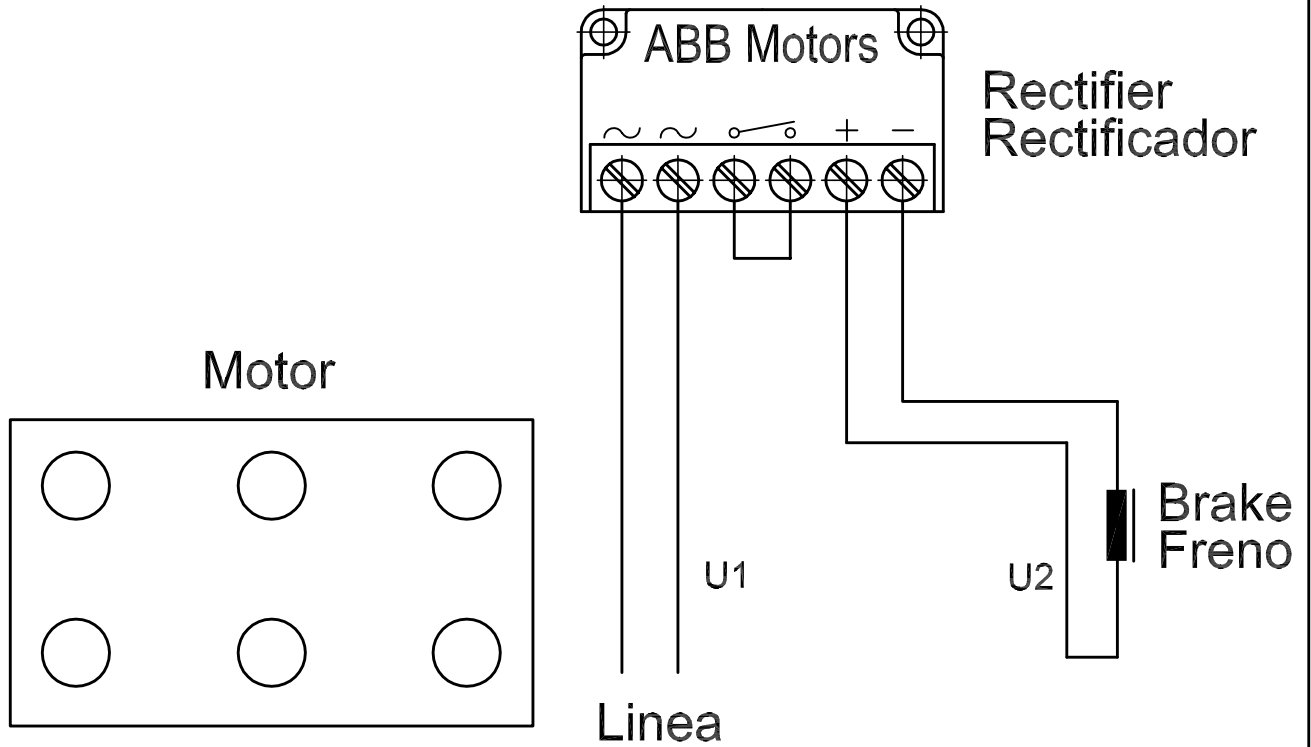

This document must not be copied without our written permission, and the contents thereof must not be imparted to a third party nor be used for any unauthorized purpose. Contravention will be prosecuted.
 ABB Automation Products, S.A. Div. Motores (ES) 2001

Form No.	Sheet	Cont.
	Year	Week
Design checked by	Rev Ind	Dept.
	Rev Ind	Revision
Drawn by	Appd.	Year Week
	Accepted by qual control	Accepted for prod by
Description(English)	ARTIGAS <i>A</i>	SANZ <i>S</i>
	CONNECTION DIAGRAM	
Description(own language)	SOLER <i>A</i>	BLANES <i>S</i>
	ESQUEMA CONEXIONES	
RevInd	Drawing checked by	Issued by
	BLANES <i>S</i>	MKI 91 17
Sheet	AC 4340 5014-7	
	2	1
Cont.	-	
	-	

2	Actualización a M3ARF	IKA	02 - 07
1	Plano pasado a sistema CAD.	MKI	94 - 39
Rev Ind	Revision	Appd.	Year Week

Accepted by qual control		Accepted for prod by		Description(English)		M3ARF 090÷160
ARTIGAS <i>A</i>		SANZ <i>S</i>		CONNECTION DIAGRAM		
Design checked by		Drawn by		Description(own language)		COD. 086
SOLER <i>A</i>		BLANES <i>S</i>		ESQUEMA CONEXIONES		
Drawing checked by		Issued by		RevInd		Sheet
BLANES <i>S</i>		MKI 91 17		2		1
ABB Automation Products, S.A.		División Motores		AC 4340 5014-7		Cont.
						-