

Effective: October 1993
Supersedes I.L. 41-766.6 dated June 1991

(I) Denotes Changed Since Previous Issue

SVV Voltage Relay



Before putting protective relays into service, remove all blocking which may have been inserted for the purpose of securing parts during shipment, make sure that all moving parts operate freely, inspect the contacts to see that they are clean and close properly, and operate the relay to check the settings and electrical connections.

1.0 APPLICATION

The SVV is a solid state voltage relay which can be set to trip for over or undervoltage applications. It may be applied with voltage continuously near pickup without the problem of chatter or contact welding. One application is for torque control of a separate overcurrent relay. The voltage must be below the pre-set undervoltage dropout level in order for the overcurrent unit to be able to operate.

2.0 CONSTRUCTION

The relay is housed in a small metal case, suitable for projection mounting, and consists of one internally mounted printed circuit module and two externally mounted power resistors in a cage. Connections to the relay are made to a six position terminal strip. The adjusting potentiometer is accessible at the top of the case cover. By removing four screws from the cover, the internal assembly may be withdrawn from the case and accessed while the

relay case remains mounted. Case outline is shown in Figure 5.

3.0 OPERATION

Refer to schematic diagram Figure 3 for operation of the relay. DC voltage is applied to terminals J1.1 and J1.2. The power supply consists of resistor R2 and zener diodes CR1 and CR2 providing +15 and -15 volts for operation of the circuit. The DC input also supplies the 12 volt dc output relay K1 through resistor R1. Chokes L1 and L2 and capacitors C3 and C4 are filters for the DC input at terminals J1.1 and J1.2.

The ac input at terminals J1.3 and J1.4 is applied to the primary of transformer T1. The secondary of T1 is connected to an input buffer consisting of C9, R10, D1, D2 and U1.1 operational amplifier. The sine wave voltage output from the buffer is fed to a full wave rectifier comprised of two operational amplifiers U1.3 and U1.4 along with resistors R16, R17, R18, R19 and diodes D4 and D5. This circuit is basically an inverting amplifier (U1.4) and a voltage follower (U1.3) whose output at TP2 is positive regardless of the polarity of the signal at pin 1 of U1.1. When the signal at pin 1 of op-amp U1.1 is positive through resistor R17, this effectively back biases diode D4, thereby disconnecting the inverting amplifier's output from pin 10 of U1.3. The output at TP2 is the same as that at pin 1 of U1.1 since this is a voltage follower circuit. When the signal at pin 1 of U1.1 is negative, the inverting amplifier applies a positive input to pin 10 of U1.3 through diode D4 at unity gain, thereby causing a positive

All possible contingencies which may arise during installation, operation or maintenance, and all details and variations of this equipment do not purport to be covered by these instructions. If further information is desired by purchaser regarding this particular installation, operation or maintenance of this equipment, the local ABB representative should be contacted.

output at TP2. The result is the full wave rectification of the ac signal at pin 1 of U1.1.

R4, potentiometer R3, and reference zener diode CR3 form a reference level for the comparator amplifier U1.2. This reference level is adjustable through potentiometer R3 which is the setting of the trip level. If the peak value of the rectified ac signal detected at TP2 is greater than the reference level setting, the U1.2 comparator output sets a retriggerable one-shot U2.1 to produce a logic "1" at TP1. Transistor Q1 will turn on to pick up the output relay K1. The relay contacts are brought out at J1.5 and J1.6. Contact output, "NO" or "NC" is selectable using the blue jumper J2 located on the printed circuit board. Component locations are shown in Figure 4.

4.0 SETTINGS

Apply rated dc voltage to terminals 1(+) and 2(-). With the jumper J2 set in the "NC" position and ac voltage set at the desired pickup level, adjust the potentiometer for relay pickup. The normally closed output contacts will open. Decrease the voltage, then increase it to the desired pickup level and check for relay operation. If necessary, readjust the potentiometer for the exact pickup level. for under-voltage applications, adjust the potentiometer, as above, for the desired relay dropout level.

5.0 CHARACTERISTICS

DC INPUT RANGE:	38-56 Vdc or 100 - 144 Vdc., Terminals 1(+), 2(-)
AC INPUT RANGE:	7-16 Vac or 35 - 85 Vac., Terminals 3, 4
OUTPUT:	N.O. or N.C. Contacts (10A @240 Vac, 30 Vdc), Terminals 5, 6

TRIP SETTING:	7-16 Vac or 35-85 Vac adjustable
ACCURACY:	1.0%
DROPOUT RATIO:	97%
OPERATE TIME:	Pickup 20-25 mSec. Dropout 16-18 mSec.
FREQUENCY RANGE:	55-65 Hz

6.0 ENVIRONMENTAL DATA

Ambient Temperature Range:	-20 to +55 deg. C.
Insulation Test Voltage:	2.8kV, dc, 1 minute (ANSI C37.90.0, IEC-255-5)
Impulse Voltage Withstand:	5kV Peak, 1.2/50 microseconds, 0.5 Joule, (IEC-255-5)
Surge Withstand Voltage:	2.5kV, 1 MHz (ANSI C37.90a, IEC-255-6)
Fast Transient Voltage:	5kV, 10/150 ns Withstand (ANSI C37.90a)
EMI Volts/Meter Withstand:	25 MHz-1GHz, 10V/m (Proposed ANSI C37.90.2).

7.0 DIMENSIONS AND WEIGHT

Height	7.75" (196.85 mm) (See Figure 3)
Width	5.25" (133.35 mm)
Depth	3.375" (85.73 mm)
Weight	3.24 lb. (1.48 kg net)

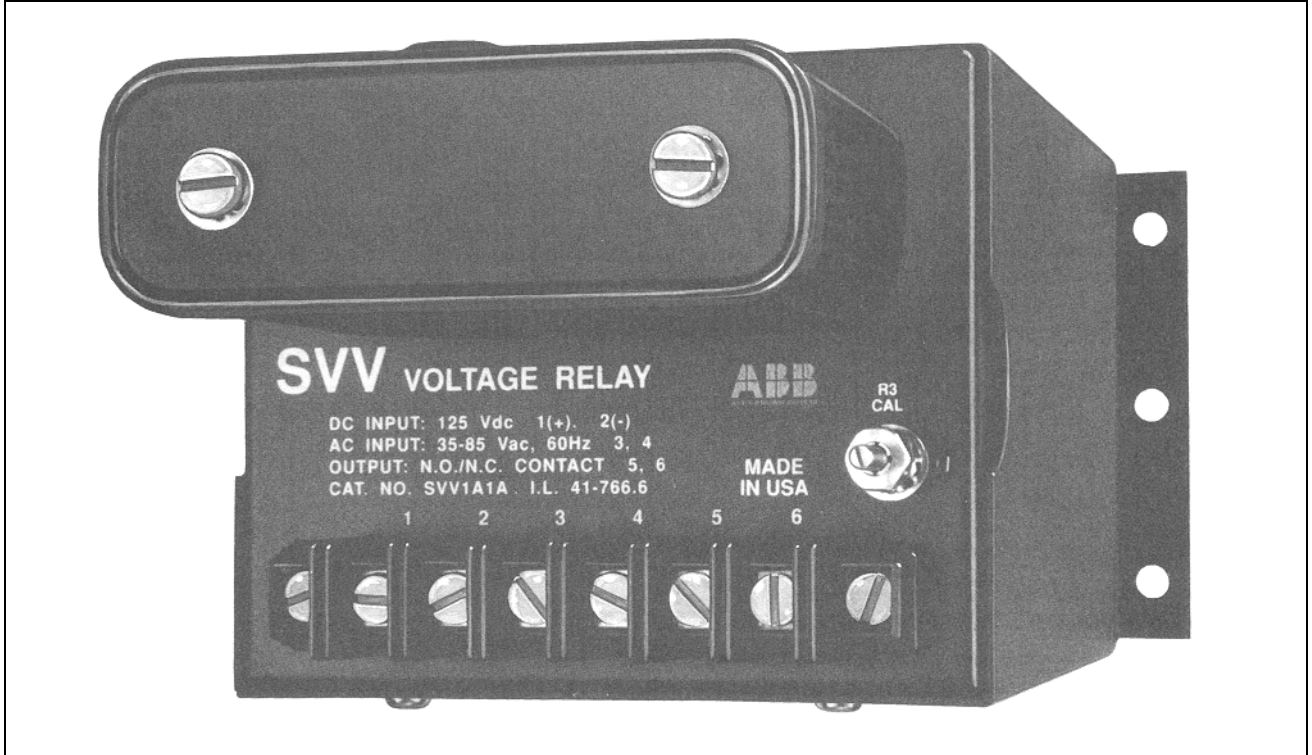

Figure 1. SVV Relay (Front View)

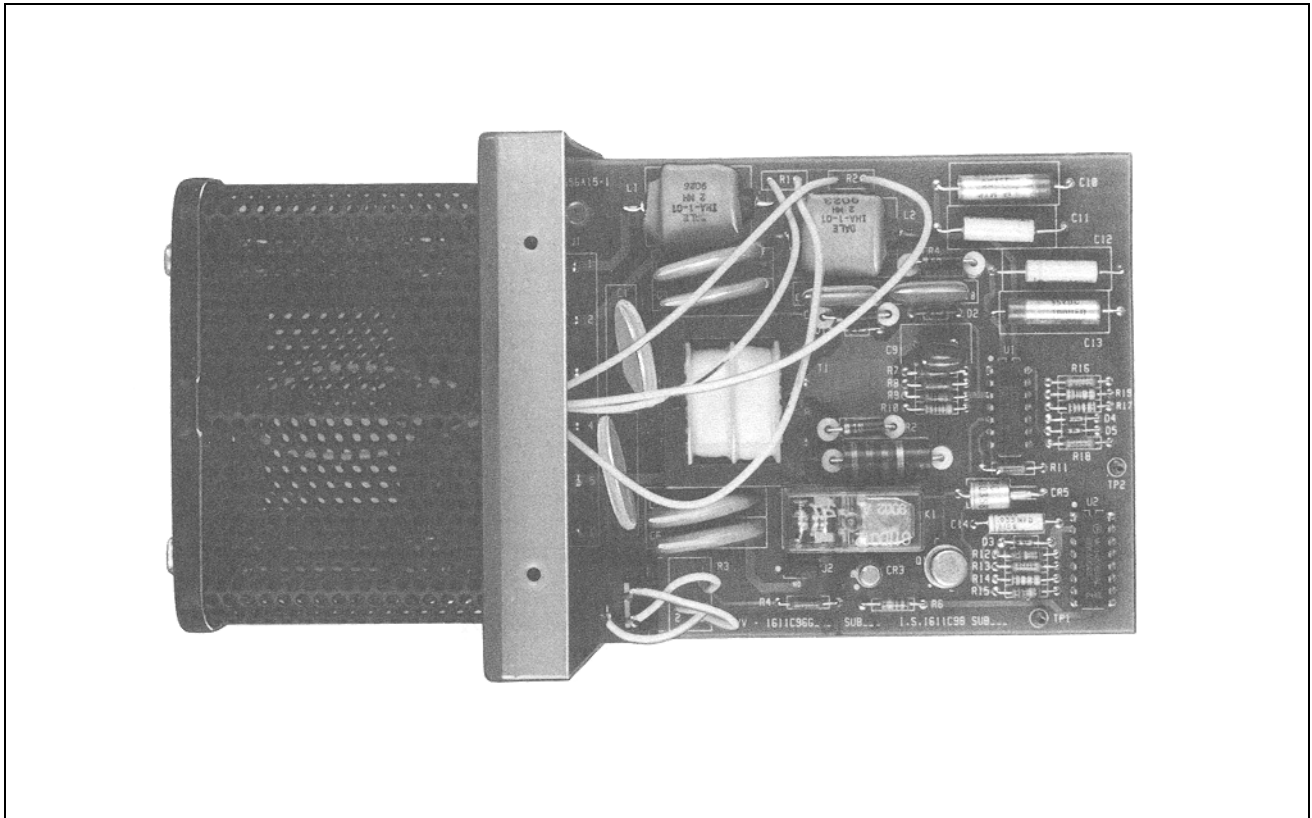
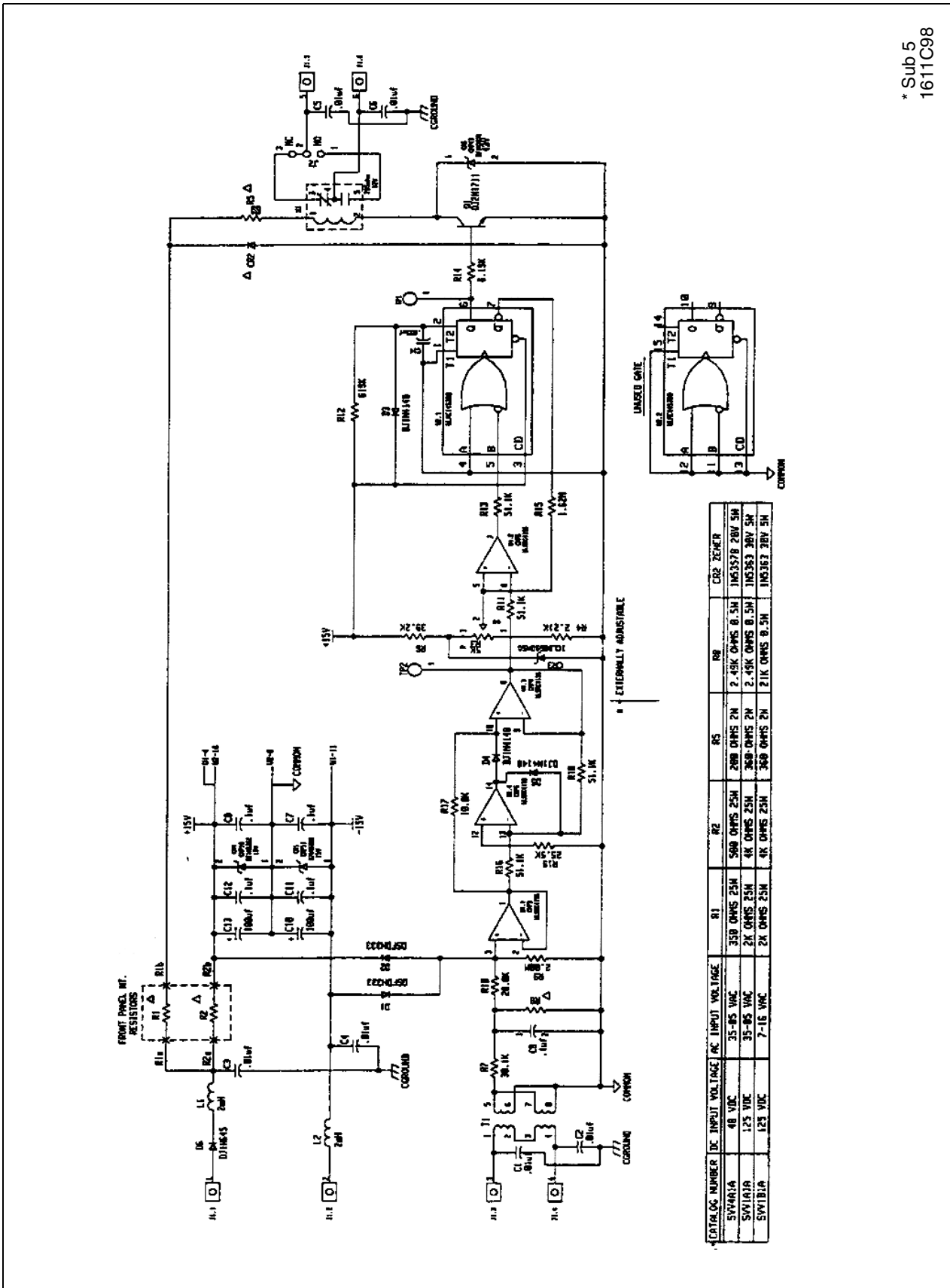
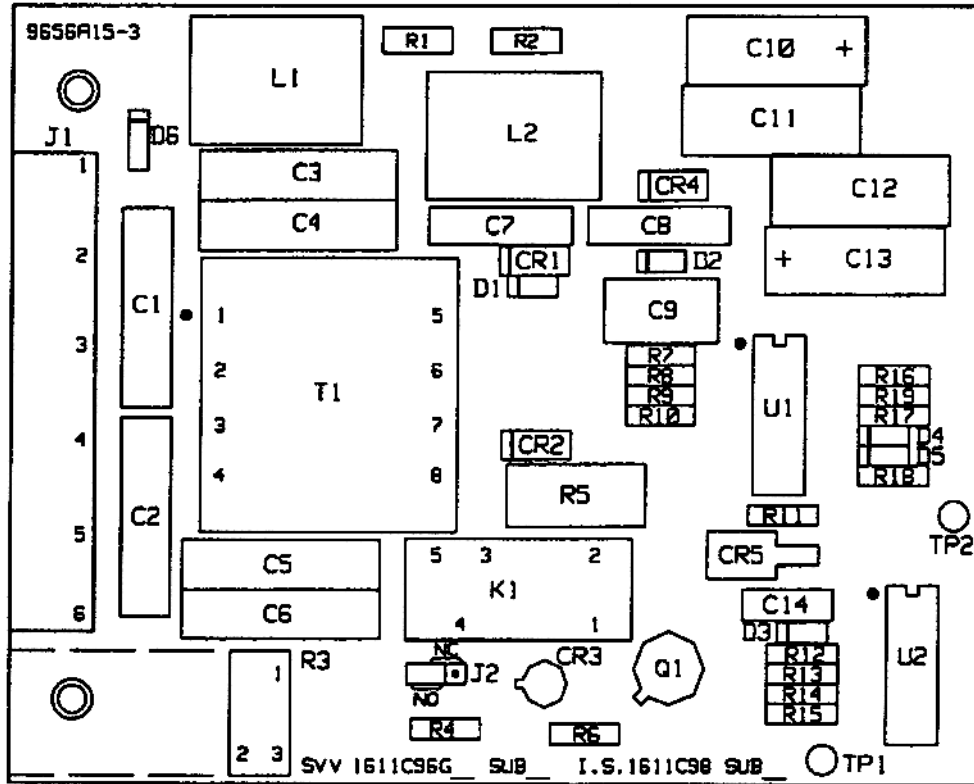

Figure 2. SVV Relay (Out of the Case)



* Sub 5
1611C98

Figure 3. Internal Schematic



* Sub 6
1611C96
Sheet 2 of 2

Figure 4. Component Location

* Denotes change

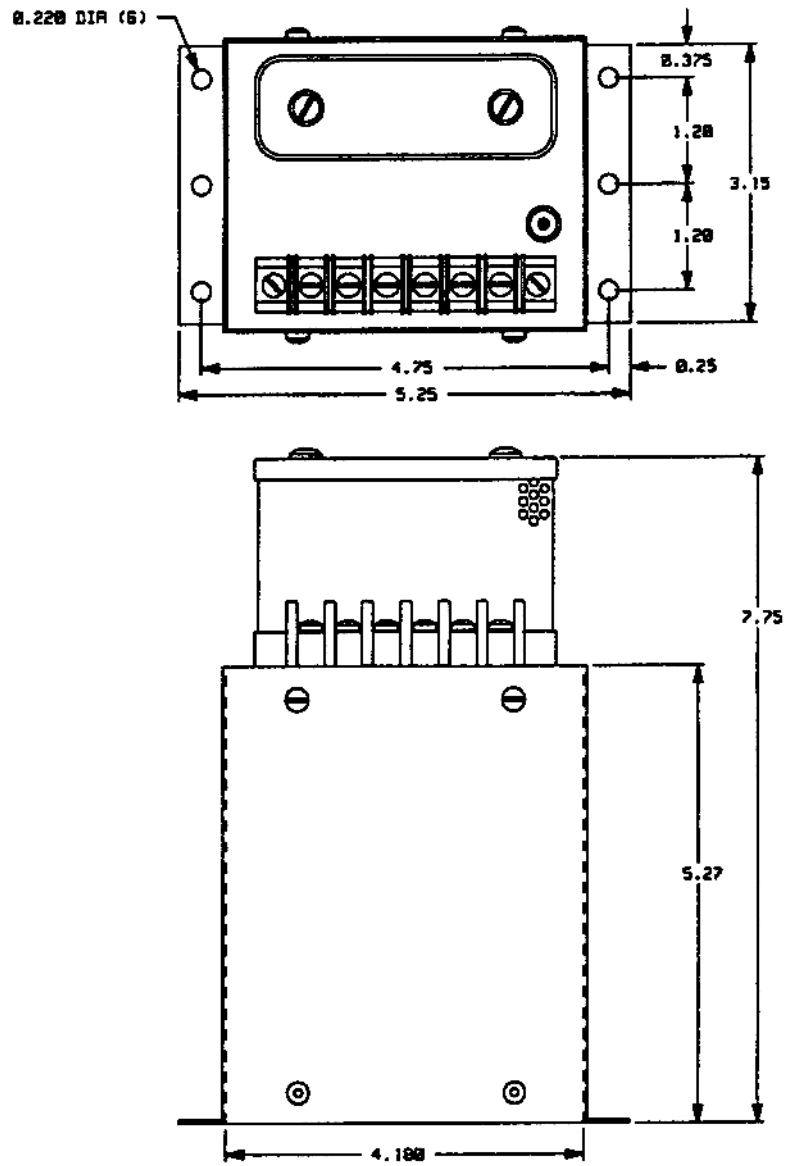

Sub 1
1612C05

Figure 5. Outline Drawing

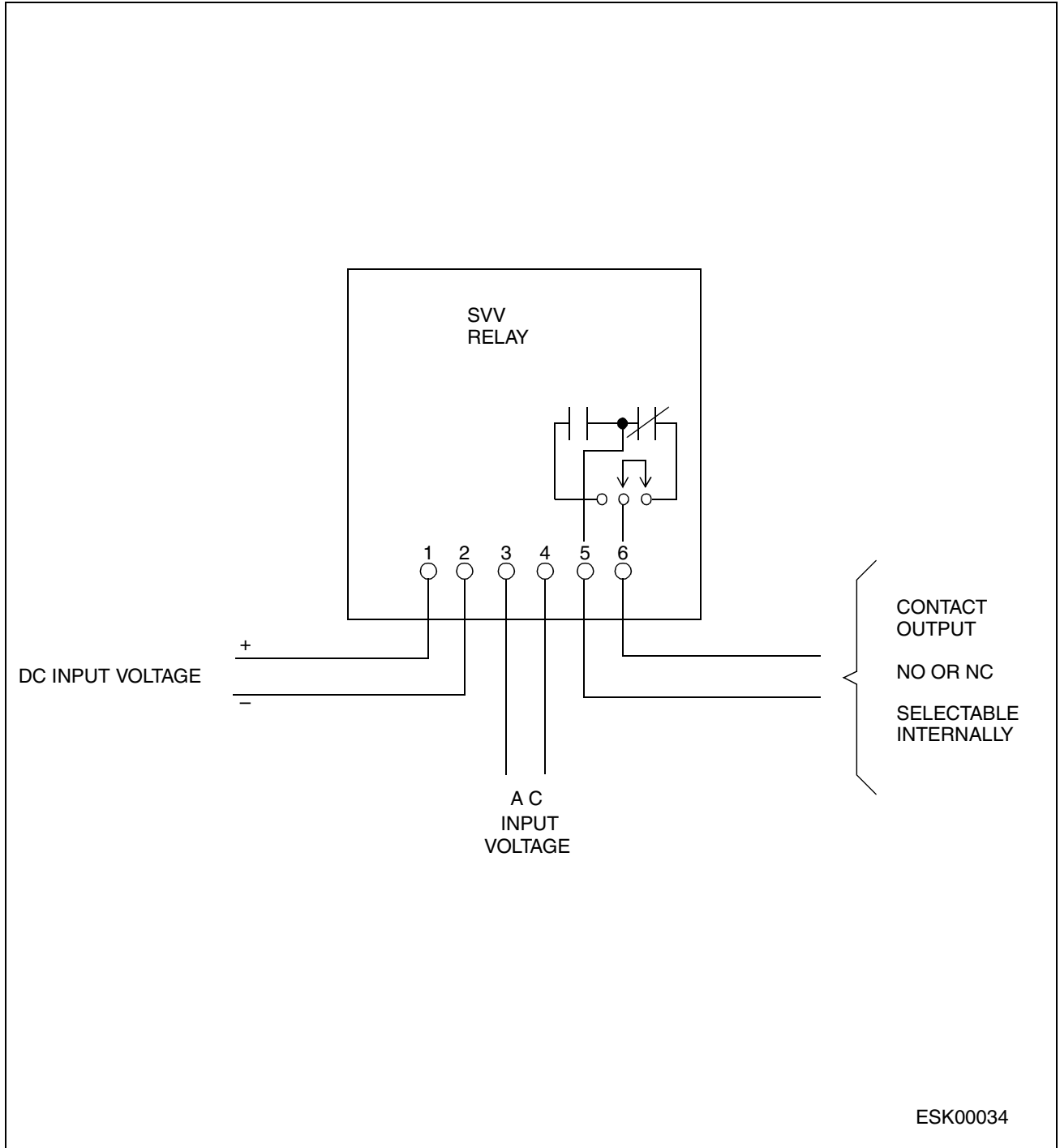

ESK00034

Figure 6. External Connections



ABB Inc.

4300 Coral Ridge Drive
Coral Springs, Florida 33065

Telephone: +1 954-752-6700

Fax: +1 954-345-5329

www.abb.com/substation_automation

IL 41-766.6 - Revision A