



Types SSV-T and SSC-T Relays for Class IE Application

Effective August 1986
Supersedes I.L. 41-766.5A dated February 1984

* Denotes change since previous issue

CAUTION: Before putting relays into service, remove all blocking which may have been inserted for the purpose of securing the parts during shipment. Make sure that all moving parts operate freely. Inspect the contacts to see that they are clean and close properly, and operate the relay to check the settings and electrical connections.

APPLICATION

These relays have been specially designed and tested to establish their suitability for Class IE applications. Materials have been selected and tested to insure that the relays will perform their intended function for their design life when operated in a normal environment as defined by ANSI standard C37.90 - 1971, when exposed to radiation levels up to 10^4 rads, and when subjected to seismic events producing a Shock Response Spectrum within the limits of the relay rating.

"Class IE" is the safety classification of the electric equipment and systems in nuclear power generating stations that are essential to emergency shutdown of the reactor, containment isolation, cooling of the reactor, and heat removal from the containment and reactor, or otherwise are essential in preventing significant release of radioactive material to the environment.

The solid state types SSC-T current relay and SSV-T voltage relay are high seismic relays and suitable for nuclear power station relaying protection. They are adjustable over a wide range of current and voltage and have a calibrated scale plate which indicates the pick-up setting. The output unit is a telephone relay and an ICS (Indicating Contactor Switch) seal-in device.

The type SSC-T and SSV-T relays have a high ratio of drop-out and are particularly suitable for use in applications requiring an accurate current or voltage level detector.

CONSTRUCTION

The type SSC-T or SSV-T relay consists of a printed circuit board with a transformer, a scale plate, an output telephone relay, and several associated components. The relay is mounted in the semi-flush FT-11 Flexitest case. The relay also includes one ICS (Indicating Contactor Switch) for indication and seal-in purposes. The relay chassis is draw-out construction for easy of test and maintenance.

The components are connected as shown in Fig. 4, 5, and 6.

Input Transformer - The input transformer is a two winding type with a center tapped secondary winding. The secondary is connected to two full wave rectifiers.

Rectifiers and DC Power Supply - There are two full wave rectifiers. One with two zener diodes and a capacitor is used as an input signal and connected to a level detector (setting) circuit. The zener diodes are also used as surge protections. The other full wave rectifier is used as dc power supply. For type SSC-T overcurrent relay, a resistor-zener diode is needed in order to keep the current transformer's linearity.

Setting Circuit - The setting circuit is connected between zener-rectifier and sensing circuit.

All possible contingencies which may arise during installation, operation, or maintenance, and all details and variations of this equipment do not purport to be covered by these instructions. If further information is desired by purchaser regarding this particular installation, operation or maintenance of this equipment, the local Asea Brown Boveri representative should be contacted.

It consists of two resistors and a potentiometer with a scale plate. The potentiometer has a locking feature to minimize accidental change of setting.

Sensing Circuit – The sensing circuit consists of a transistor, a zener diode, and several associated components. It is actually a level detector. If the input voltage from the rectifier is high enough to break down the zener diode, the output transistor will be turned on.

Output Circuit – The output circuit consists of a transistor driver and a telephone relay. The overcurrent relay (SSC-T) has a telephone relay equipped with 2-A type contacts. The over or under voltage relay (SSV-T) has a telephone relay equipped with 1-A and 1-B type contacts.

Indicating Contactor Switch (ICS) – The Indicating contactor switch is a small dc operated clapper type device. A magnetic armature to which leaf-spring mounted contacts are attached. It is attracted to the magnetic core upon energization of the switch. When the switch closes the moving contracts bridge two stationary contacts completing the trip circuit. Also during this operation, two fingers on the armature deflect a spring located on the front of the switch which allows the target to drop. The target is reset from the outside of the case by a push rod located at the bottom of the cover.

OPERATION

The block diagrams of the SSV-T and SSC-T are shown in Fig. 1, 2, and 3 and the internal schematic are shown in Fig. 4, 5, and 6. For overvoltage and overcurrent application, the transistor Q2 is normally not conducting and the telephone relay is deenergized. The transistor Q1 is used as an emitter follower. When ac voltage or current is applied to the primary of the transformer (T) a voltage is produced on the secondary side that is proportional to the input. The potentiometer (R2) is for the pick-up setting. If the voltage from rectifier (Z1, Z2, and C2) is large enough to exceed the breakdown voltage of zener diode Z5, the zener diode conducts to turn on the transistor Q2 and operate the telephone relay.

For undervoltage application, the transistors Q1 and Q2 are normally conducting and the telephone relay is pulled in. As soon as the input voltage drops below the setting, the transistor Q2 is turned off and the telephone relay is released.

CHARACTERISTICS

★ 1. Overcurrent Relay SSV-T

Range	Continuous Rating
0.5 – 2 amps	2 amps
2.0 – 8 amps	8 amps
4.0 – 16 amps	10 amps
10 – 40 amps	10 amps

- ★ 1 Second Rating
28, 112, 280 and 280 Amps for the above ranges respectively

Operating Frequency... 50/60 Hz

Temperature Error 2% between – 20°C and 65°C.

Dropout Ratio..... 90% to 98%

Response Time

Pickup Time = 10-13 ms

- ★ Dropout Time = 10-26 ms

For 2 to 15 times pickup setting value (Fig. 10)

Transient Overreach ... 5%

Burden Table I

Frequency Response... Fig. 12

- ★ Telephone Relay Contacts
0.1 Amps at 125 Vdc

2. Over/Undervoltage Relay SSV-T

Range 60 – 140 Volts
140 – 320 Volts
280 – 640 Volts

- Continuous Rating Highest voltage of range setting.
- Operating Frequency. . . . 50/60 Hz.
- Temperature Error 2% between -20°C and $+65^{\circ}\text{C}$
- ⊕ Dropout Ratio. 92% to 99% (Fig. 13)
- Response Time Pickup Time –
7–10 ms
Dropout Time –
14–40 ms (Fig. 9)
- Burden 1 VA at 120 volts
60 hertz
- ⊕ Telephone Relay Contacts
0.1 Amps at 125 Vdc

TABLE I (60 hertz)

Range (Amps)	Pickup Current Setting			
	Lowest Setting		Highest Setting	
	VA	P.F. Angle β	VA	P.F. Angle β
0.5 – 2.0	0.5	8.5°	4.0	12.5°
2.0 – 8.0	0.5	8.5°	5.0	12.5°
4.0 – 16.0	0.5	8.5°	5.0	12.5°
10.0 – 40.0	0.8	10.0°	8.0	10.7°

Trip Circuit

The main contacts will safely close 30 amperes at 250 volts dc and the seal in contacts of the indicating contactor switch (when supplied) will safely carry this current long enough to trip a circuit breaker. The indicating contactor switch (when supplied) has a pickup of approximately 1 ampere. Its dc resistance is 0.37 ohms.

SETTINGS

The relay must be set for the desired levels of voltage or current. The pickup of the relay is made by adjusting the potentiometer in the front of the relay. Setting in between the scale marking can be made by applying the desired voltage or current and adjusting the potentiometer until the telephone relay operates.

INSTALLATION

The relays should be mounted on switchboard panels or their equivalent in a location free from dirt, moisture, excessive vibration and heat. Mount the relay vertically by means of the four mounting holes on the flange for the semi-flush type FT case. The mounting screws may be utilized for grounding the relay. External toothed washers are provided for use in the locations shown on the outline and drilling plan to facilitate making a good electrical connection between the relay case, its mounting screws and the relay panel. Ground Wires are affixed to the mounting screws as required for poorly grounded or insulating panels. Other electrical connections may be made directly to the terminals by means of screws for steel panel mounting.

For detail information on the FT case refer to I.L. 41-076 for semi-flush mounting.

ADJUSTMENT AND MAINTENANCE

The proper adjustments to insure correct operation of this relay have been made at the factory and should not be disturbed after receipt by the customer.

Acceptance Tests

The following check is recommended to insure that the relay is in proper working order. Refer to the internal schematics and apply voltage or current to the proper terminals.

1. Minimum Trip Current – Check pickup at minimum and maximum settings. This is accomplished by applying the specified voltage or current and checking the pickup of the output telephone relay when the ac input is within $\pm 5\%$ of the settings.

2. Dropout Ratio – After checking pickup, gradually reduce the input. The dropout should be greater than 92% and 90% of the pickup for SSV-T and SSC-T relays respectively.

Indicating Contactor Switch (ICS)

Close the main relay contacts and pass sufficient dc current through the trip circuit to close the contacts of the ICS. This value of current should be not greater than ICS's rated current. The operation indicator target should drop freely.

The contact wipe should be approximately 0.016 inches. The bridging moving contact should touch both stationary contacts simultaneously.

ROUTINE MAINTENANCE

All relays' calibration should be checked and contacts should be cleaned at least once every year. A contact burnisher S#182A836H01 is recommended for cleaning purpose. It is recommended to change the potentiometer R2 every ten years.

CALIBRATION

Use the following procedure for calibrating the relay if the relay adjustments have been disturbed. This procedure should not be used until it is apparent that the relay is not in proper working order. A new scale plate may be necessary when parts are changed.

- Dial Calibration –
1. Connect an ohmmeter across proper relay terminals which connect to the telephone relay contacts.
 2. Apply the desired voltage or current to relay terminals 8 and 9.
 3. Turn potentiometer on front of relay counter-clockwise from extreme clockwise position until the relay operates as indicated by the ohmmeter.

Indicating Contactor Switch (ICS)

Initially adjust unit on the pedestal so that armature fingers do not touch the yoke in the

reset position. This can be done by loosening the mounting screw in the molded pedestal and moving the ICS in the downward position.

1. Contact Wipe – Adjust the stationary contacts so that both stationary make with the moving contacts simultaneously and wipe 1/64" to 3/64" when the armature is against the core.

For double trip ICS units, adjust the third contact so that it makes with its stationary contact at the same time as the two main contacts or up to 1/64" ahead.

2. Target – Manually raise the moving contacts and check to see that the target drops at the same time as the contacts made or up to 1/16" ahead. The cover may be removed and the tab holding the target reformed slightly if necessary. However care should be exercised so that the target will not drop with a slight jar.

3. Pickup – Unit should pickup at 98% of rating and not pickup at 85% of rating. If necessary the cover leaf springs may be adjusted. To lower the pickup current use a tweezer or similar tool and squeeze each leaf spring approximate equal by applying the tweezer between the leaf spring and the front surface of the cover at the bottom of the lower window.

If the pickup is low the front cover must be removed and the leaf spring bent outward equally.

RENEWAL PARTS

Repair work can be done most satisfactorily at the factory. However, interchangeable parts can be furnished to customers who are equipped for doing repair work. When ordering parts, always give the complete nameplate data.

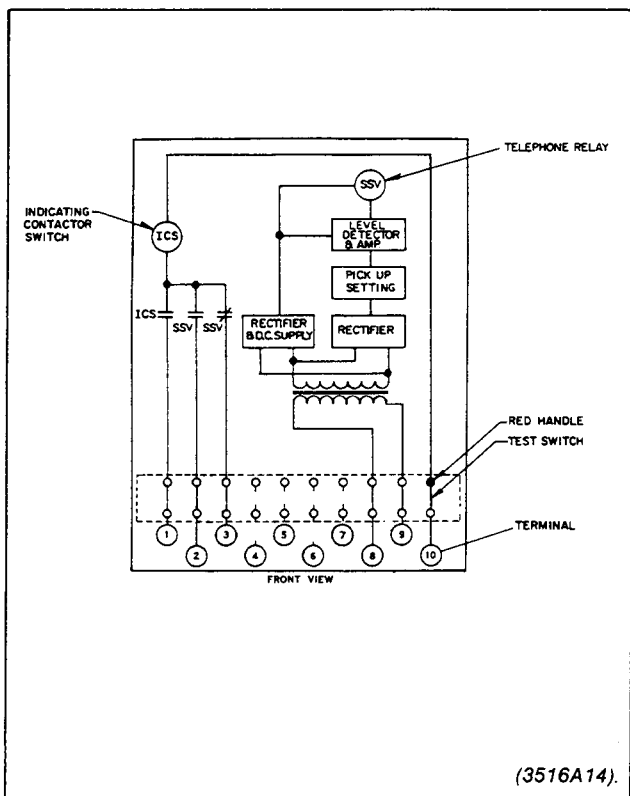

Fig. 1. Block Diagram of the Type SSV-T Relay in the Type FT-11 Case

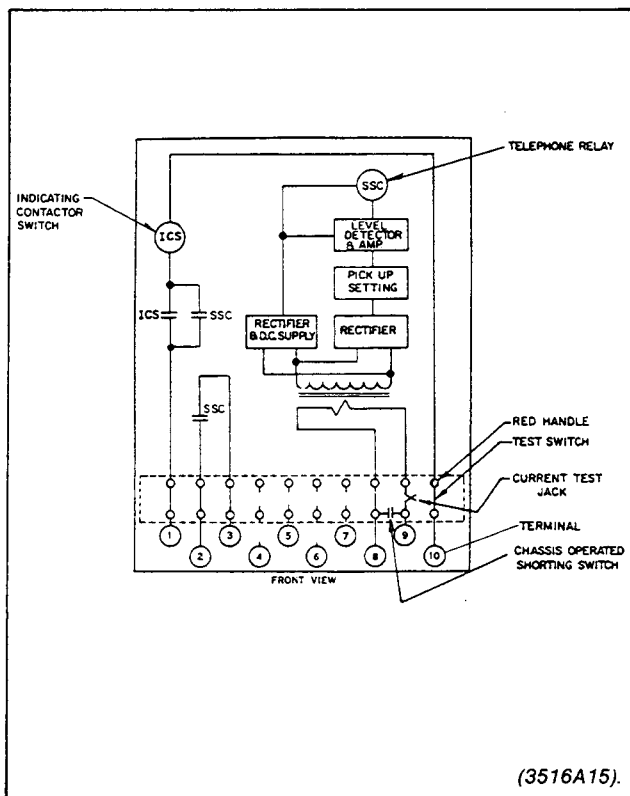

Fig. 2. Block Diagram of the Type SSC-T Relay in the Type FT-11 Case

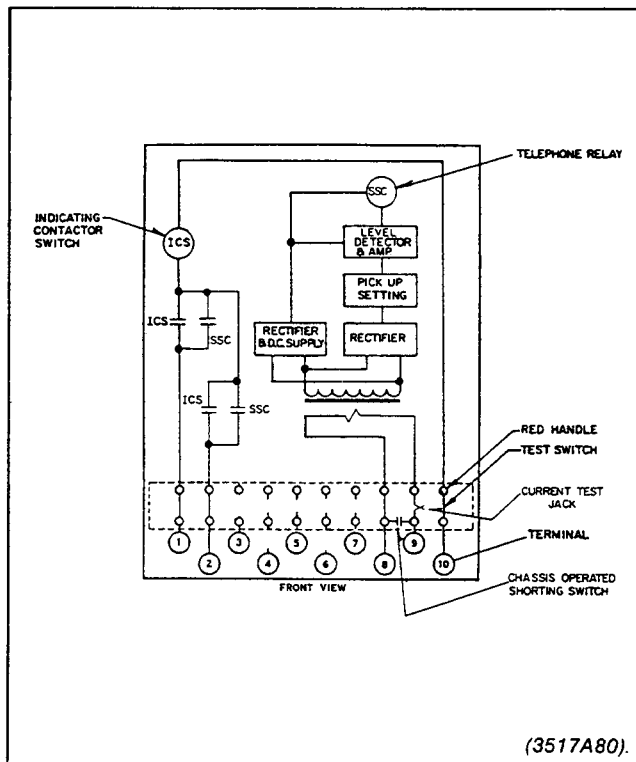

Fig. 3. Block Diagram of the Type SSC-T Relay (Double Trip)

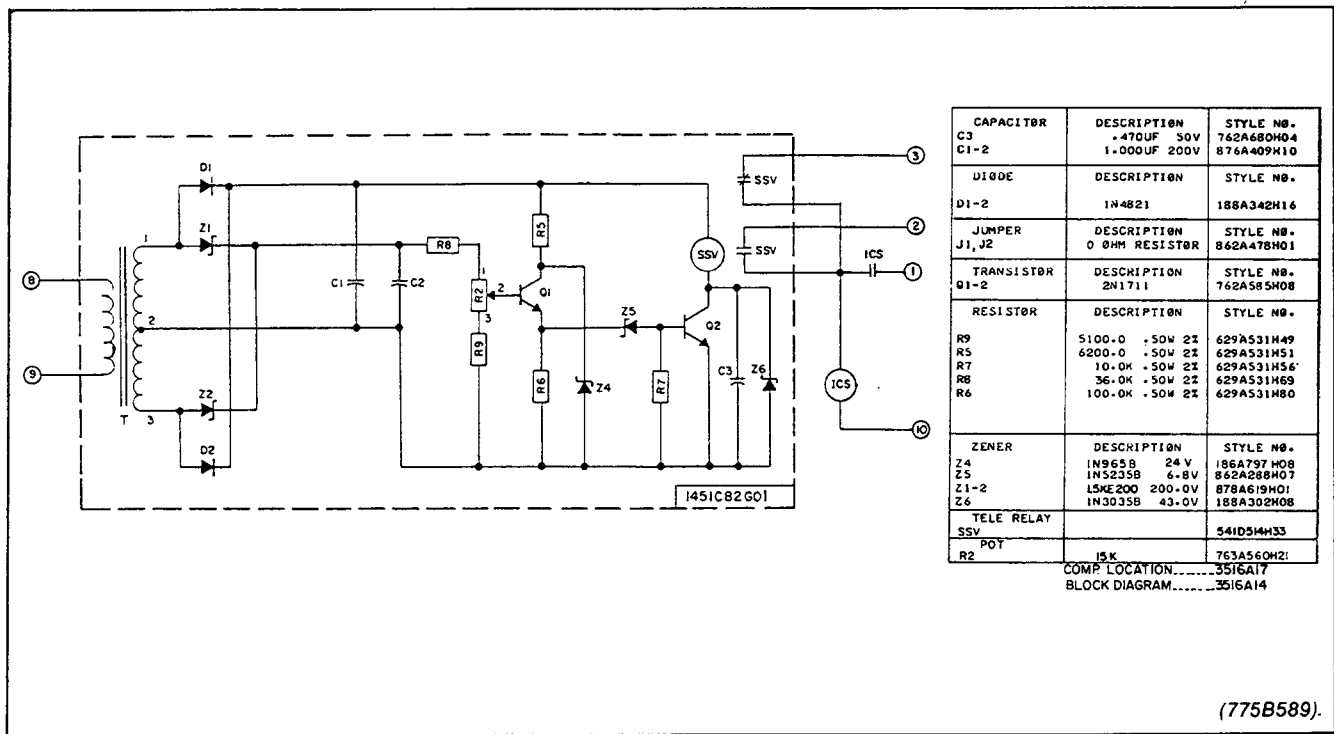
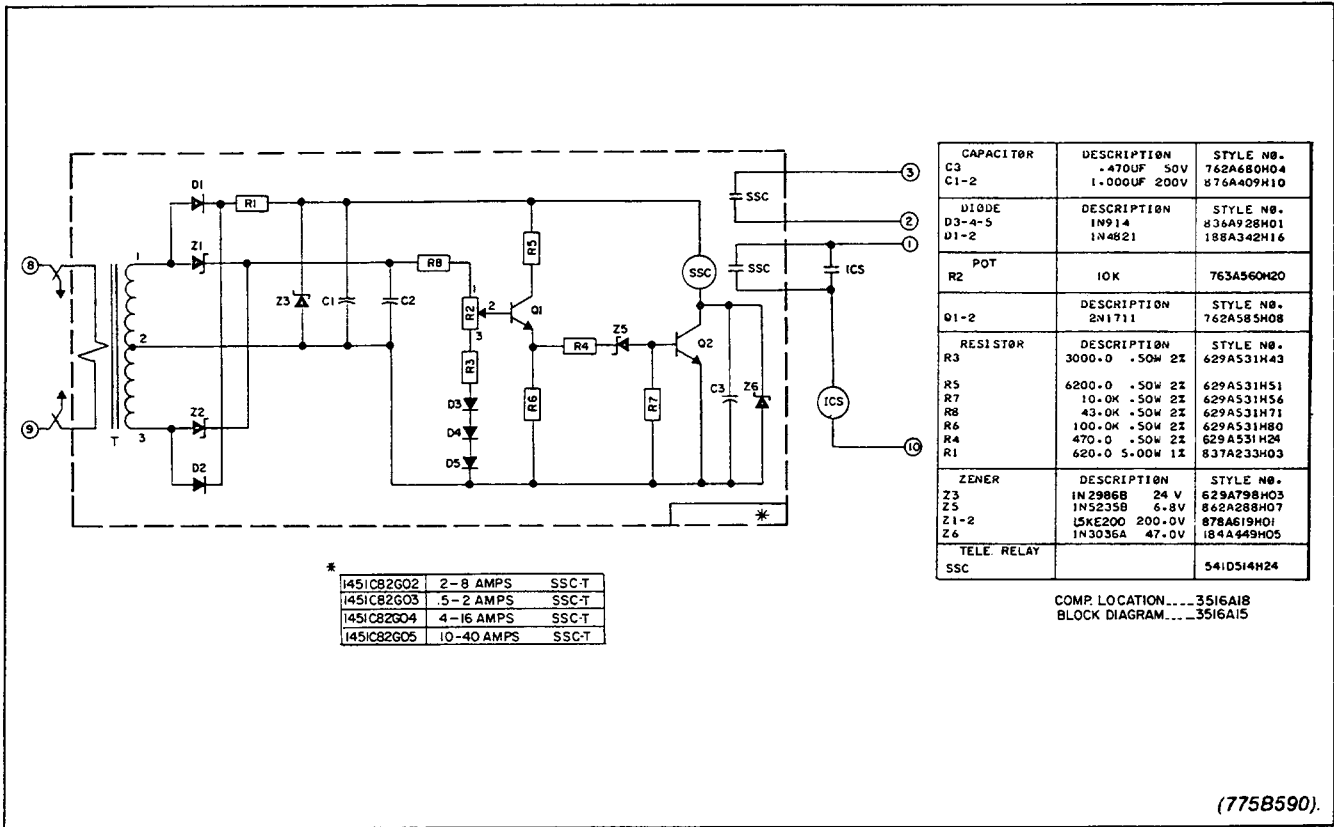

Fig. 4. Internal Schematic of the Type SSV-T Relay

(775B589).



*

145IC82G02	2-8 AMPS	SSC-T
145IC82G03	5-2 AMPS	SSC-T
145IC82G04	4-16 AMPS	SSC-T
145IC82G05	10-40 AMPS	SSC-T

Fig. 5. Internal Schematic of the Type SSC-T Relay

(775B590).

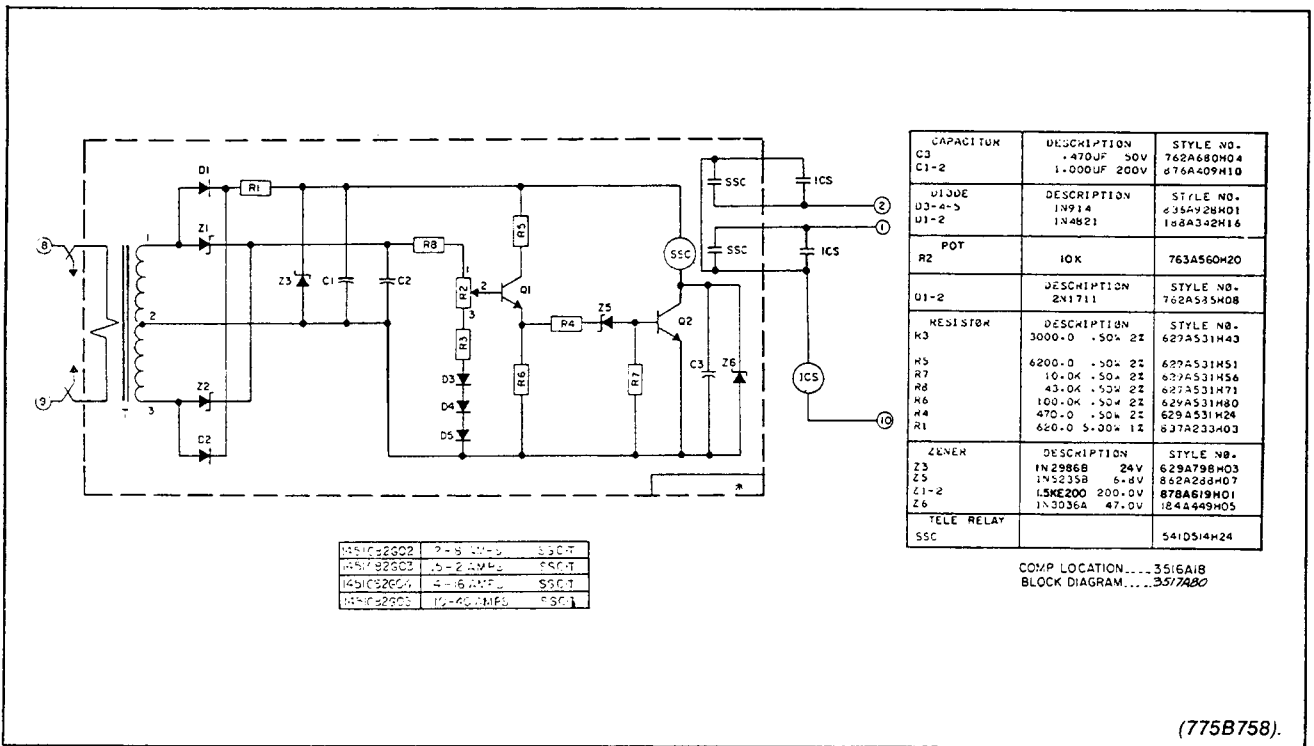

(775B758).

Fig. 6. Internal Schematic of the Type SSC-T Relay (Double Trip)

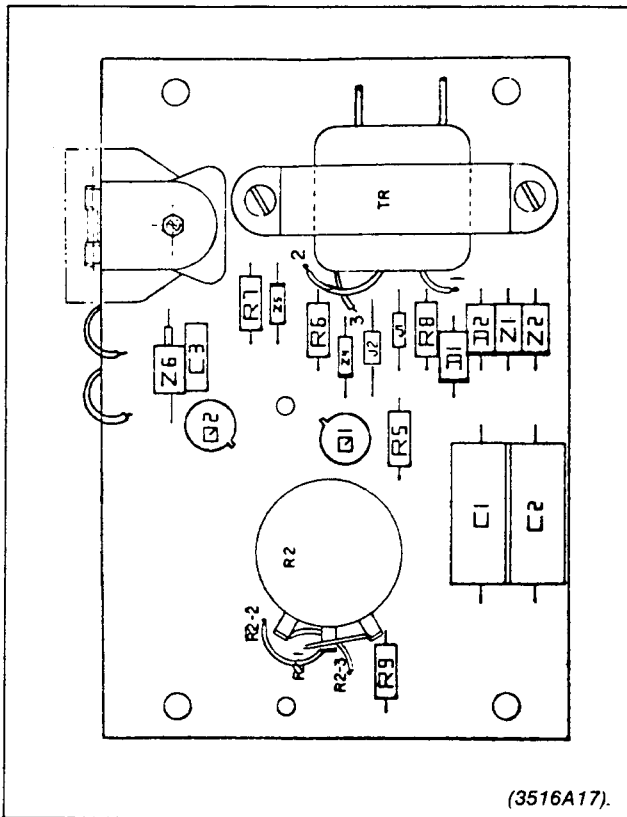

Fig. 7. Component Location on SSV-T Module

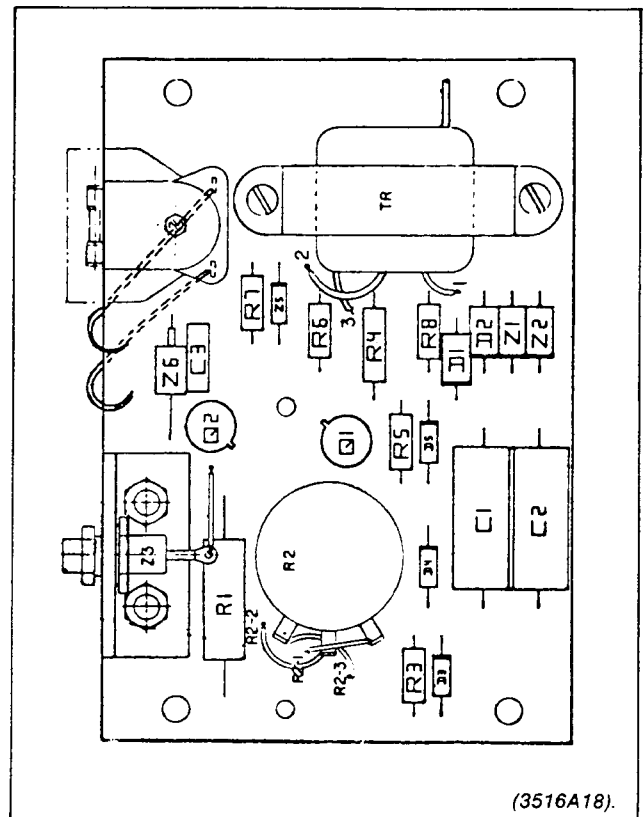

Fig. 8. Component Location on SSC-T Module

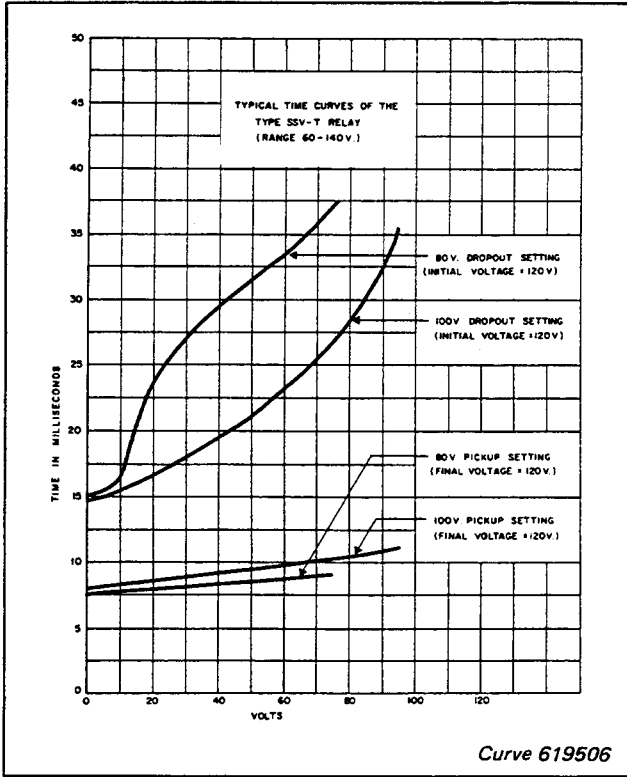

Fig. 9. Typical Operating and Reset Time Curves of the Type SSV-T Relay

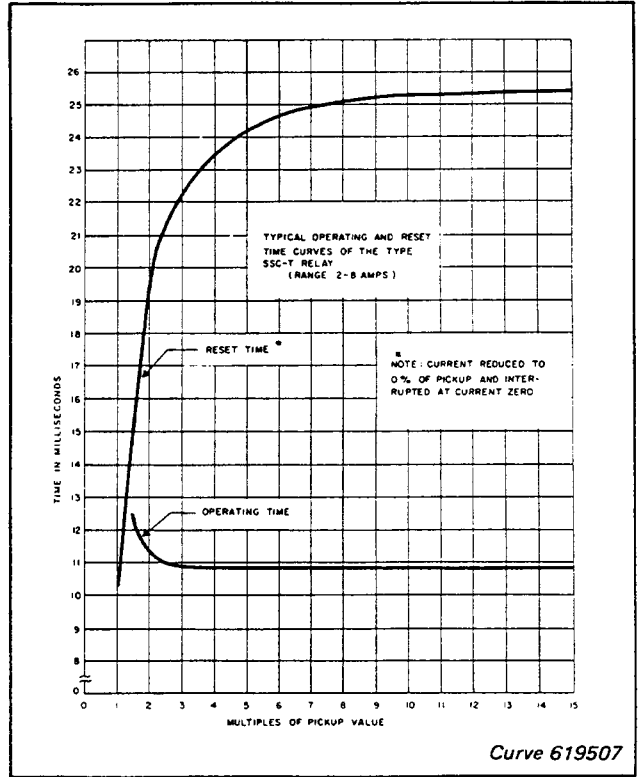

Fig. 10. Typical Operating and Reset Time Curves of the Type SSC-T Relay

CURVE NO. 619504

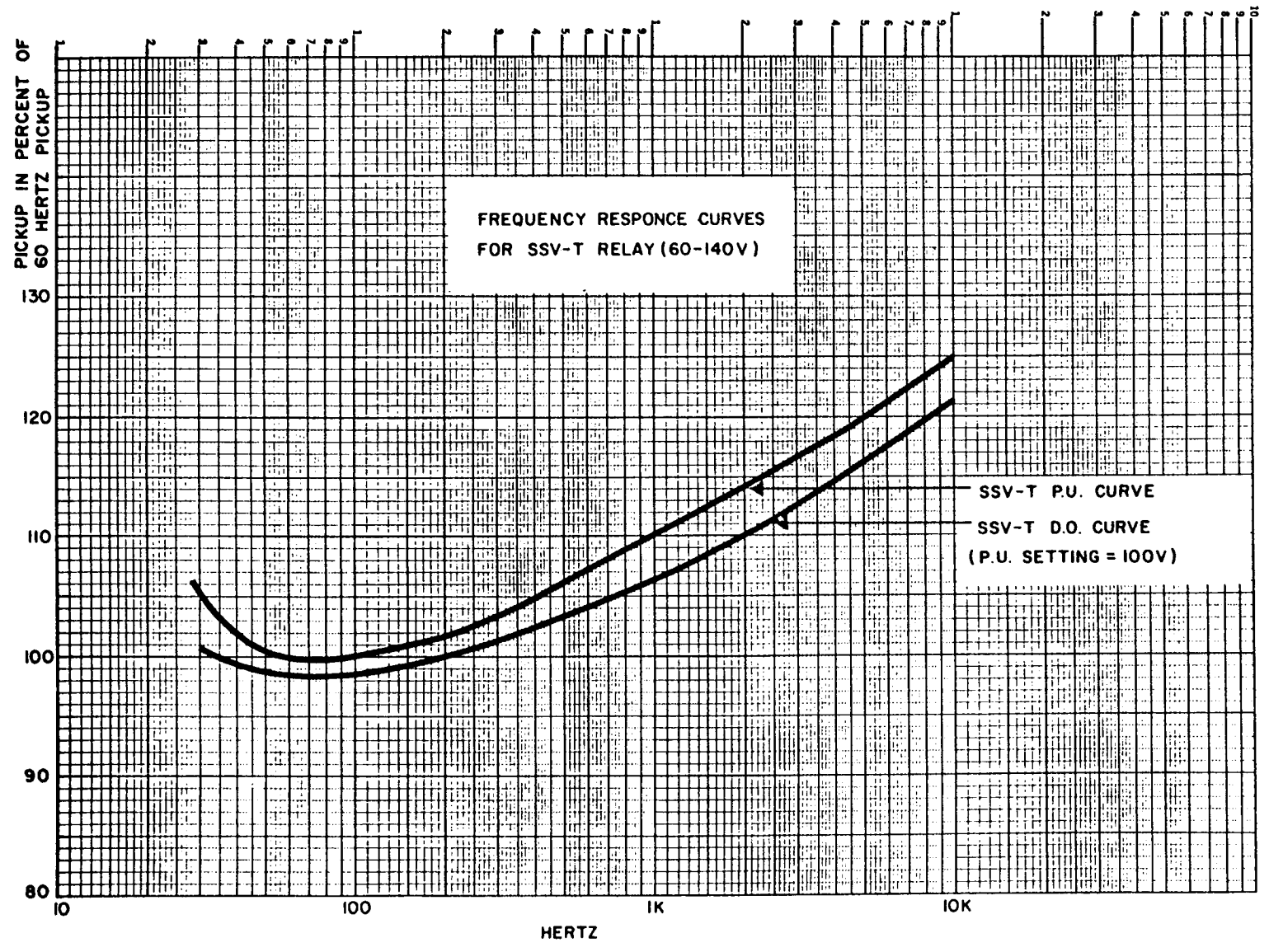
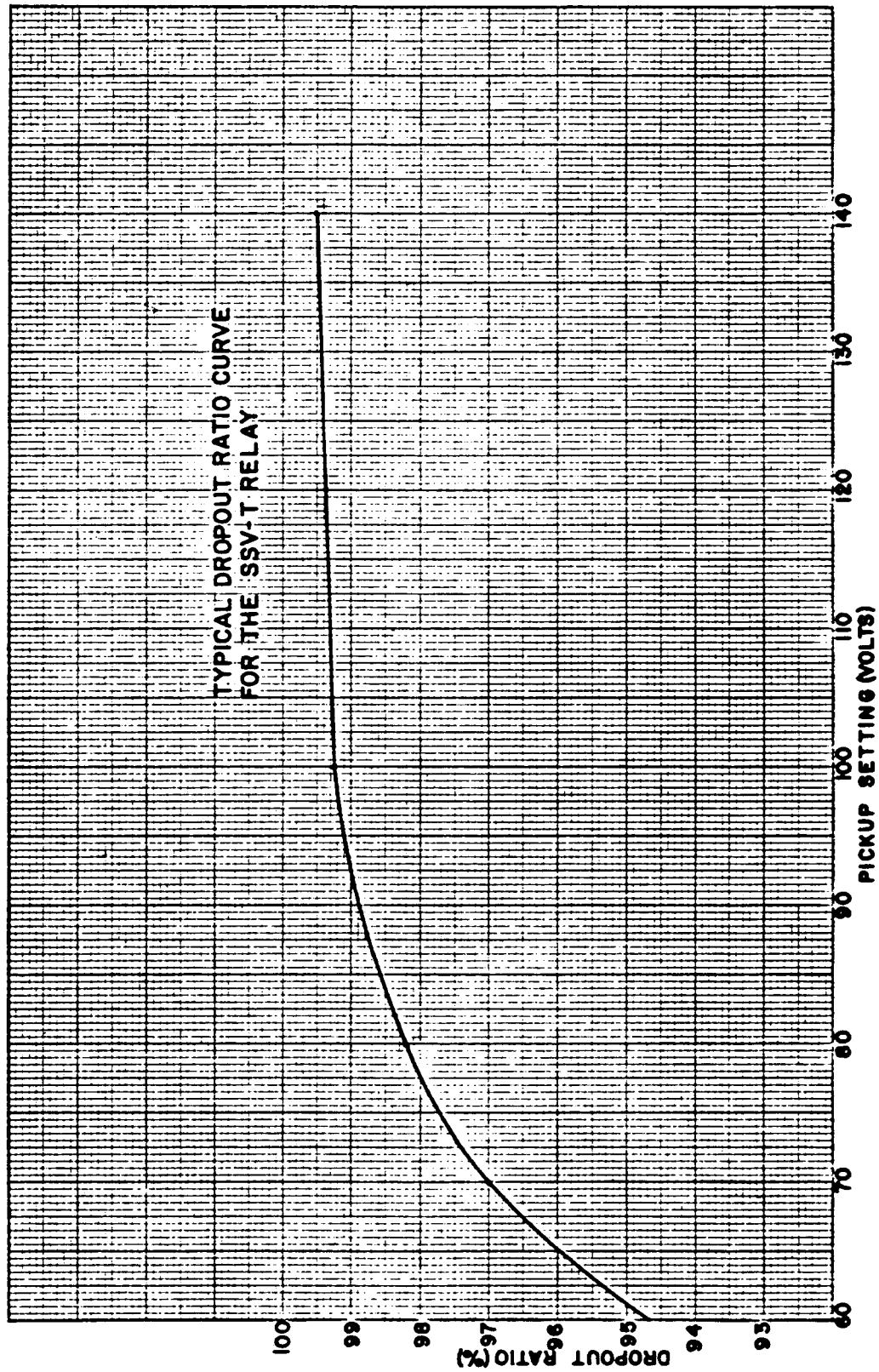

Fig. 11. Typical Frequency Response Curve of the Type SSV-T Relay

619504



Curve 619567

★ Fig. 13. Typical Dropout Ratio Curve for the SSV-T Relay

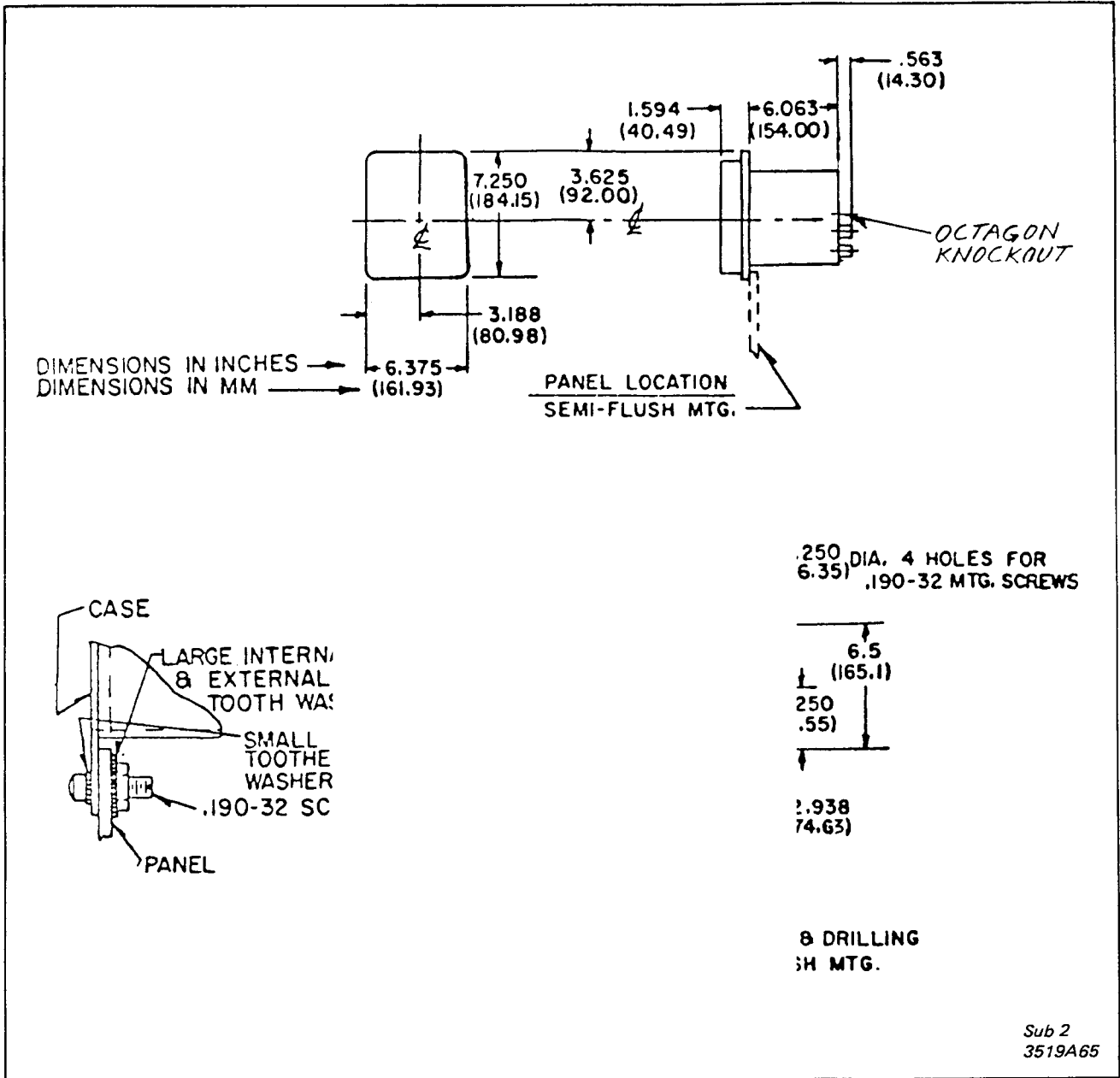

★ Fig. 14. Outline and Drilling Plan for the Type SSV-T and SSC-T Relay in Semi-Flush FT-11 Case

ABB Power T&D Company Inc.
 Relay Divisions • Coral Springs, FL 33065