



LWT SIL FUNCTIONAL SAFETY GUIDE

## LWT series

Guided wave transmitter



---

# Disclaimer

This Guide and any accompanying software are copyrighted and all rights are reserved by ABB Inc. This product, including software and documentation, may not be copied, photocopied, reproduced, translated, or reduced, in whole or in part, to any electronic medium or machine-readable format without prior written consent from ABB.

This document contains product specifications and performance statements that may be in conflict with other ABB published literature, such as product fliers and catalogs. All specifications, product characteristics, and performance statements included in this document are given as indications only. In case of discrepancies between specifications given in this document and specifications given in the official ABB product catalogs, the latter takes precedence.

ABB reserves the right to make changes to the specifications of all equipment and software, and contents of this document, without obligation to notify any person or organization of such changes. Every effort has been made to ensure that the information contained in this document is current and accurate. However, no guarantee is given or implied that the document is error-free or that the information is accurate.

ABB makes no representations or warranties with regard to the product and instructional and reference materials, including, but not limited to, all implied warranties of merchantability and fitness for a particular purpose.

ABB does not warrant, guarantee, or make any representations regarding the use, or the results of the use, of any software or written materials in terms of correctness, accuracy, reliability, currentness, or otherwise. ABB shall not be liable for errors or omissions contained in its software or manuals, any interruptions of service, loss of business or anticipatory profits and/or for incidental or consequential damages in connection with the furnishing, performance or use of these materials, even if ABB has been advised of the possibility of such damages.

All equipment, software, and manuals are sold as is. The entire risk as to the results and performance of the equipment and software is assumed by the user.

The software or hardware described in this document is distributed under a license and may be used, copied, or disclosed only in accordance with the terms of such license.

© ABB, 2019

---

# Table of Contents

## 1 Introduction

Terms and abbreviations.....	5
Acronyms.....	6
Support.....	7
Applicable documents .....	7
Reference documents .....	7

## 2 Description

Instrument version.....	10
-------------------------	----

## 3 Designing a SIF using the LWT instrument

Safety function.....	12
Alarm response and current output.....	12
Overall safety accuracy.....	14
Specific instrument modes and parameters for safety operation.....	14
Behavior for undetected faults.....	14
Environmental limits.....	14
Applications limits.....	14
Design verification .....	14
SIL capabilities .....	15
Systematic integrity.....	15
Random integrity.....	15
Safety parameters .....	15
General requirements.....	16

## 4 Installation and commissioning

Installation.....	17
Physical location and placement.....	17
Electrical connection.....	17
Commissioning .....	17
Checklist before safety operation.....	18
Adding password protection .....	18
Enabling/Disabling the write protection..	18
Verify safety function .....	19

## 5 Operation and maintenance

Proof test .....	21
Testing the instrument.....	21
Possible error messages .....	23
Maintenance.....	23
Repair .....	23

Software updates.....	23
Useful life.....	23
ABB notification .....	23

## 6 Document status

Change record .....	25
IEC-61508 certificate.....	25

**Page intentionally left blank**

## CHAPTER 1

# Introduction

The purpose of this safety guide is to provide the information necessary to design, install, verify, and maintain a Safety Instrumented Function (SIF) utilizing the LWT series. This guide provides the necessary requirements for meeting the IEC 61508 functional safety standards.

This chapter defines terms, abbreviations and acronyms used in this document. It also exposes reference documents and how to get product support.

## Terms and abbreviations

Term	Meaning
Basic Safety	The equipment must be designed and manufactured such that it protects against risk of damage to persons by electrical shock and other hazards, and against resulting fire and explosion. The protection must be effective under all conditions of the nominal operation and under single fault condition.
Continuous Mode	Mode where the safety function retains the EUC in a safe state as part of normal operation.
Fail Annunciation Detected	Failure that does not cause a false trip or prevent safety function but does cause loss of an automatic diagnostic or false diagnostic indication.
Fail Annunciation Undetected	Failure that does not cause a false trip or prevent the safety function but does cause loss of an automatic diagnostic and is not detected by another diagnostic.
Fail Dangerous	Failure that does not respond to a demand from the process (i.e. being unable to go to the defined fail-safe state).
Fail Dangerous Detected	Failure that is dangerous but is detected by automatic stroke testing.
Fail Dangerous Undetected	Failure that is dangerous and that is not being diagnosed by automatic stroke testing.
Fail No Effect	Failure of a component that is part of the safety function but that has no effect on the safety function.
Fail-Safe State	State where the output current is $\leq 3.6$ mA (fail low) or $\geq 21$ mA (fail high)
Fail Safe	Failure that causes the current output to go to the defined fail-safe state without a demand from the process.
Functional Safety	The ability of a system to carry out the actions necessary to achieve or to maintain a defined safe state for the equipment under control of the system.
High Demand Mode	Mode, where the frequency of demands for operation made on a safety related system is more than one per year.
Low Demand Mode	Mode, where the frequency of demands for operation made on a safety related system is not more than one per year.
Multidrop	Multidrop Mode. In Multidrop Mode, multiple devices are connected in parallel to a single wire pair. The analog current signal simply serves to supply power to the devices in two-wire technology with a fixed current.

Term	Meaning
Safety	Freedom from unacceptable risk of harm.
Safety function	A specified function that is performed by a safety-related system with the goal, under consideration of a defined hazardous incident, of achieving or maintaining a safe condition for the plant.
Safety related system	A safety related system performs the safety functions that are required to achieve or maintain a safe condition.
Ullage	The distance by which a container falls short of being full.

## Acronyms

Acronym	Definition
DC	Diagnostic Coverage
DCS	Distributed Control System. Control system used in industrial applications to monitor and control decentralized units.
DTM	Device Type Manager. A DTM is a software module that supports specific functions for accessing device parameters, the setup and the operation of devices, and diagnostics. The DTM is not executable software. It requires a FDT container program to be activated.
DUT	Device Under Test
EDD	Electronic Device Description
EUC	Equipment Under Control
FDT	Field Device Tool
FMEDA	Failure Modes, Effects and Diagnostic Analysis
HART	Highway Addressable Remote Transducer
HFT	Hardware Fault Tolerance. Ability of a functional unit (hardware) to continue to perform a required function when faults or errors are prevailing.
HMI	Human Machine Interface. In this case, the HMI is a combined module consisting of an LCD display with 4 buttons keypad.
LRV	Lower Range Value. Device Configuration, LRV of the measurement range
MTBF	Mean Time Between Failures
MTTR	Mean Time To Restoration. Mean time between the occurrence of an error in a unit or in a system and its repair.
PFD	Probability of Failure on Demand
PFD <sub>AVG</sub>	Average Probability of Failure on Demand
SFF	Safe Failure Fraction. Proportion of non-hazardous failures; in other words, the proportion of failures without the potential to put the safety-related system in a hazardous or impermissible state.
SIF	Safety Instrumented Function. A set of equipment intended to reduce the risk due to a specific hazard.
SIL	Safety Integrity Level. The international standard IEC 61508 defines four discrete Safety Integrity Levels (SIL 1 to SIL 4). Each level corresponds to a range of probability for the failure of a safety function. The higher the Safety Integrity Level of the safety-related systems, the lower the probability that they will not perform the required safety function.
TI	Proof Test Interval
URV	Upper Range Value. Device Configuration, URV of the measurement range.

# Support

Additional documentation on LWT300/400 series is available for download free of charge at <https://new.abb.com/products/measurement-products/level/guided-wave-radar-level-transmitters/LWT>.

Product support can be obtained by contacting ABB by one of the means indicated on the back cover of this guide.

## Applicable documents

The following documentation must be available with the LWT instrument and shall be read in addition to this safety guide.

---

AD1	3KXL001069U0100	LWT300 GWR Level Transmitter User Guide	<a href="https://new.abb.com/products/measurement-products/level/guided-wave-radar-level-transmitters/LWT">https://new.abb.com/products/measurement-products/level/guided-wave-radar-level-transmitters/LWT</a>
AD3	DS/LWT300-EN	LWT300 Datasheet	<a href="#">LWT</a>

---

These documents include details about functional specifications of the analog output and how to operate and configure the device.

## Reference documents

---

RD1	IEC 61508 (2010) (Edition 2), Part 1 to 7	Functional safety of electrical/electronic/programmable electronic safety-related systems. International standard published by International Electro-technical Commission (IEC).
-----	---	--

---

**Page intentionally left blank**



---

## CHAPTER 2

# Description

The LWT series is specifically made for industrial applications and harsh environments. It provides continuous level measurement capabilities for process automation and inventory management in industries. It provides precise measurement of any solid or liquid independently from the material properties.

The LWT series of instruments are microprocessor-based level transmitters that use very low power microwave energy to determine the level of the product being measured. A rod or cable “probe” is hung into the vessel to act as a waveguide, i.e. microwave energy stays concentrated around the length of the probe instead of being dispersed, as it would be if there was no probe.

Depending on the type of configuration, it can meet the demands of hazardous area locations, and high pressure and high temperature applications. Ordering specifications are described in the LWT data sheet (AD2). Refer to this datasheet to get exact measuring range, operating temperature and accuracy specifications. The LWT is explosion-proof class 1, division 1.

Additional documentation on LWT series instruments is available for download at

<https://new.abb.com/products/measurement-products/level/guided-wave-radar-level-transmitters/LWT>.



# Instrument version

This safety manual applies to guided wave sensor LWT series, with the most up to date revision in this table:

<b>Safety Release Number</b>	<b>Release Date</b>	<b>Software Revision\ Hardware Revision</b>	<b>Release Notes</b>
1	8 February 2019	1.00.02\19.02.08	Initial safety version
2	30 September 2019	1.00.04\19.09.30	Updated to fix infrequent missed frames between internal electronic modules observed on some instruments. Updated software for compatibility with Hardware Revision 19.09.30.

# Designing a SIF using the LWT instrument

Figure 1 shows a safety function example with an LWT instrument. The vessel level is monitored by the guided wave level transmitter. The LWT 4–20 mA output loop is proportional to the level, ullage or volume of the vessel. Configuration of the LWT can be performed directly on its HMI or with the HART communication protocol through a computer or handheld terminal. The LWT connects to the user logic device to control one or multiple actuators for process control and SIF.

**Figure 1** Safety function with LWT monitoring a vessel and user logic controlling it

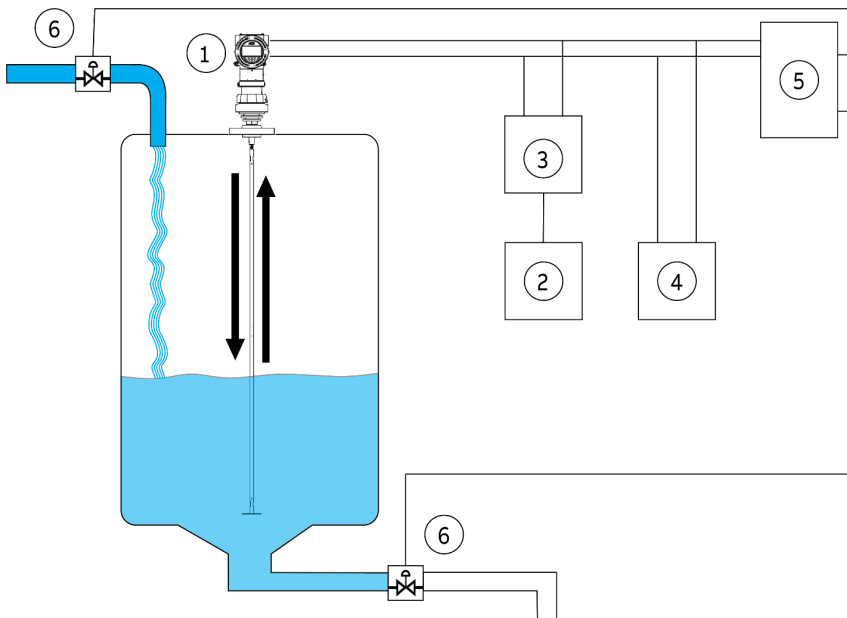

Number	Description
①	LWT instrument
②	Computer with FDT and LWT DTM
③	HART FSK modem
④	Handheld terminal
⑤	Automation system, Logic-unit, PLC or other logic device
⑥	Actuator

# Safety function

The guided wave level transmitter produces an analog signal, between 4 and 20 mA, proportional to the level, volume or ullage, as defined by the operator. The analog signal is fed to a downstream logics unit such as a PLC or a limit signal generator, and monitored for exceeding a specified maximum or minimum value. All safety functions refer exclusively to this analog output. The total valid range of the output signal shall be configured to a minimum of 3.6 mA and a maximum of 20.5 mA (factory defaults).

The LWT provides the following Type-B safety functions:

- Computes a distance/level measurement.
- Outputs a 4–20 mA signal of the transformed measurement.
- Measurement transformations are user-defined (math functions). These functions can be either on or off. Multiple parameters can be set related to:
  - Damping
  - Linearization function
  - Filtering

The safety related function of the transmitter is the safe monitoring of the level within an accuracy of 2 % of span (2 % of 16 mA). The safe state output current can be configured to be  $\leq 3.6$  mA (low alarm) or  $\geq 21.0$  mA (high alarm), with the exception of CPU faults, where the current output is in low alarm mode ( $\leq 3.6$  mA), and 4–20 mA output readback faults, where current output is set to low alarm ( $\leq 3.6$  mA) for lower than expected current and high alarm ( $\geq 21.0$  mA) for higher than expected current.

There are other functionalities of the LWT that are not considered as part of the safety function:

- Digital input (optional, external)
- HART communication
- HMI (optional)
- Remote display (optional accessory)

## Alarm response and current output

In case of detected critical faults, the configured alarm current will be produced and fed to a subsequent logic unit, e.g., a DCS, and monitored for violation of a defined maximum value.

### Selectable alarm current modes

There are two selectable modes for this alarm current:

- HIGH (max alarm current) which is the factory default setting;
- or
- LOW (min alarm current).

### DCS configuration

For safe fault monitoring, the following conditions must be fulfilled:

- The LOW ALARM must be configured with a value of  $\leq 3.6$  mA;
- or
- The HIGH ALARM must be configured with a value  $\geq 21.0$  mA.
- The DCS must be capable of recognizing the selected configured high alarms or low alarms as a malfunction detection.

- For safe current output operation, the terminal voltage at the device must be between 15.5 V and 42 V, with a minimum of 21 V for HART functionality.

The DCS loop must provide the required voltage level even if the current output operates on the configured HIGH alarm.

The DCS shall be able to latch a detected high or low alarm, as the LWT alarm state may not be maintained after the alarm-triggering condition is not met anymore.

### **Power On behavior**

On startup, the LWT current output will follow the following sequence:

- 1** Low alarm mode ( $\leq 3.6$  mA) for approximately 1 s;
- 2** High alarm mode ( $\geq 21.0$  mA) for a duration between 20 s and 40 s due to internal power management constraints.
- 3** Transition to intermediate value for approximately 1 s:
  - For level mode, go to high alarm mode ( $\geq 21.0$  mA)
  - For distance mode, go to lower range value (4.0 mA)
  - For ullage or level mode, go to lower alarm mode ( $\leq 3.6$  mA).

If a CPU fault occurs at startup during the instrument self-test, the current output is in low alarm mode ( $\leq 3.6$  mA).

### **Power failure alarm behavior**

As demonstrated through fault insertion testing, some internal hardware failures may cause the LWT to undergo a perpetual reset loop behavior which will be similar to its power on behavior as described above:

- 1** Low alarm mode ( $\leq 3.6$  mA) for approximately 1 s;
- 2** High alarm mode ( $\geq 21.0$  mA) for approximately between 10 and 20 s.

### **Behavior of transition to alarm current**

The 4–20 mA output transition from nominal measurement to alarm current is performed in the following manner:

- 1** Nominal current output (e.g., 9.8 mA)
- 2** Transition to intermediate value for one measurement cycle, thus approximately 0.2 s:
  - 4.0 mA if primary value (PV) is set to Ullage or Distance
  - $\geq 21.0$  mA if primary value (PV) is set to Level
- 3** Alarm current; high or low as described in “Selectable alarm current modes” on page 12.

### **Conditions when device is not safety-compliant**

The device is not safety-compliant during the following conditions:

- During configuration
- When HART multidrop mode is activated
- During simulation
- During proof test of the safety function

The fraction of failures without the potential to put the device into a dangerous function status is given by the SFF value shown in “Safety parameters” on page 15.

## Overall safety accuracy

The defined value for the safety threshold of the safety function of this device is: 2 % of 4–20 mA span (2 % of 16 mA).

## Specific instrument modes and parameters for safety operation

For the proper operation in a Safety Instrumented System, parameters shall have the following values:

Parameter	Value
Echo Lost Period	[0, 600] s
Echo Lost Reaction	Failure
Alarm Delay	0 s
Blocking Distance	0

## Behavior for undetected faults

If a LWT fault occurs and is not detected through its internal diagnostics, the safety function may output a current between 4 and 20 mA, which exceeds its specified safety accuracy or is not proportional to the level, volume or ullage as defined by the operator.

## Environmental limits

The designer of a SIF must check that the product is rated for use within the expected environmental limits. Refer to the user guide (AD1) or datasheet (AD2) for accurate information about environmental limits. Some limits depend on the model and configuration installed on it.

LWT measurements can be affected by vapor in high-temperature and high-pressure applications. The LWT series provides gas phase compensation algorithms for such applications. However, this results in a differing specification for accuracy. Reference distance must be verified during the commissioning phase. More information can be found in AD1 or AD2.

LWT measurements can be affected by high vibration levels which can lead to the instrument not meeting the accuracy specification listed in AD3 or AD4.

The user shall perform verifications to ensure that proper measurements can be made in the target application environment.

## Applications limits

LWTs can have flanges made of various types of metal. It is important for the designer to check for material compatibility considering on-site chemical contaminants and air supply conditions. If the LWT is used outside of the application limits or with incompatible materials, the reliability data provided could become invalid.

## Design verification

A failure mode, effects and diagnostics analysis (FMEDA) summary report is available from ABB Inc. This report details all the failure rates and failure modes as well as the expected lifetime of the LWT instrument.

The achieved SIL of an entire SIF design must be verified by the designer via a calculation of  $PFD_{AVG}$  considering architecture, proof test interval, proof test effectiveness, any automatic diagnostics, average repair time and the specific failure rates of all products included in the SIF. Each subsystem must be checked to ensure compliance with minimum hardware fault tolerance requirements.

The safety parameters used for SIL calculation of the SIF are shown in “Safety parameters” below.

## SIL capabilities

### Systematic integrity

The product meets systematic integrity requirements for SIL 3. A SIF designed with this product must not be used at a SIL level higher than the statement without prior-use justification by the end user or diverse technology redundancy in the design.

### Random integrity

The LWT is a type B device. Therefore, based on the  $SFF \geq 90\%$ , when the LWT is used as the only component in a final element subassembly, a design can meet SIL 2 at  $HFT=0$ . When the final element assembly consists of many components, the SIL must be verified for the entire assembly using failure rates from all components. This analysis must account for any hardware fault tolerance and architecture constraints.

### Safety parameters

The table below shows the failure rate information obtained from the FMEDA and other useful information.

**Table 1** Characteristics as per IEC 61508

Parameter	Value
Type of assessment	By design
Safety Integrity Level	2
Systematic capability	3
HFT	0
Component type	B
Measuring mode	Low demand mode, High demand mode
SFF	94.1 %
MTTR	24 h
MTBF	76 years
Diagnostic coverage	$\lambda_{dd} / (\lambda_{dd} + \lambda_{du}) \approx 91.7\%$
Diagnostic test interval	<15 min
Reaction time to process change	<1 s (with no damping or filtering)
Measurement time interval	<1 s
Proof test effectiveness	80.9 %

**Table 2** Failure rates

$\lambda_s$	$\lambda_{dd}$	$\lambda_{du}$	PFH
320.7 FIT	727.8 FIT	65.9 FIT	$0.066 \times 10^{-6}$ failures/hr

**Table 3**  $PFD_{AVG}$

Ti (years)	1	2	3	4	5
$PFD_{AVG}$	$0.8 \times 10^{-3}$	$1.0 \times 10^{-3}$	$1.3 \times 10^{-3}$	$1.5 \times 10^{-3}$	$1.7 \times 10^{-3}$
Ti (years)	6	7	8	9	10
$PFD_{AVG}$	$2.0 \times 10^{-3}$	$2.2 \times 10^{-3}$	$2.4 \times 10^{-3}$	$2.7 \times 10^{-3}$	$2.9 \times 10^{-3}$

All safety related parameters are calculated using the *Siemens SN29500 Component Reliability Handbook* for a temperature of 25 °C.

### Considerations for High demand mode

In high demand mode, the end user shall comply with IEC61508-2 sections 7.4.5.3 and 7.4.5.4 for the failure rates to be applicable.

If compliance to these specified sections is not met, the end user shall contact ABB (see back cover of this document) to calculate appropriate failure rates.

## General requirements

The user shall verify that the LWT is suitable for use in safety applications by confirming that the instrument has a metallic tag installed on it and that this tag shows the information illustrated below:



The figure below provides an example of this metallic ID tag installed on a LWT instrument.

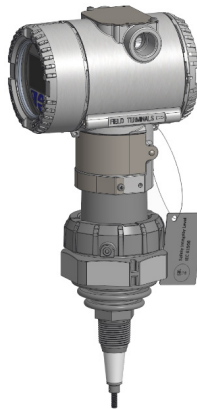

Personnel performing maintenance and testing on the LWT shall be competent to do so. Results from proof tests shall be recorded and reviewed periodically.



# Installation and commissioning

Only qualified and authorized specialists should be charged with the installation, electrical connection, commissioning, operation, and maintenance of LWT instruments.

## Installation

The guided wave level transmitter must be installed with standard practices outlined in the user guide (AD1 or AD2). Environmental parameters such as temperature and pressure, to name a few, must be checked to verify that they do not exceed the LWT ratings. As far as possible, the measuring setup should be free from critical ambient conditions such as vibrations, shocks, and large variations in temperature.

## Physical location and placement

The LWT shall be accessible with sufficient room for electrical connection and shall allow manual proof testing, as described in “Proof test” on page 21.

## Electrical connection

See the user guide (AD1 or AD2) for electrical connection instructions. Connection details like wire gauges and maximum lengths of cable are described in this guide. Make sure that the LWT is grounded according to national and local electrical codes. Outside installations or installations exposed directly or indirectly to lightning discharges should have a secondary lightning protection module.

**Do NOT** make electrical connections unless the electrical code designation stamped on the LWT data plate matches the classification of the area in which you want to install the LWT.

## Commissioning

The LWT needs to be configured before first use, since it comes with a factory default configuration. This instrument can be configured with the local HMI, with the DTM via the HART interface or with a handheld terminal. Configuring the device with the local HMI is documented in the user guide. During configuration, safe operation of the device shall not be assumed.

## Checklist before safety operation

The following items must be checked before safety operation:

- After each startup (power on) of the device, as a part of a safety function, check that the device and its configuration fulfill the safety function of the system.
- Check that the right device is installed on the right measuring point.
- Make sure that the vessel empty (LRV) and vessel full (URV) parameters correspond to real values with appropriate units.
- After every change to the device, as a part of a safety function, such as a change to the installation position of the device, process type change or configuration of safety parameters, the safety function of the device shall be verified (see “Verify safety function” on page 19).
- After the safety function has been checked, device operation must be locked because a change to the measuring system or parameters can compromise the safety function. The **write protection shall be enabled** before powering up when it is desired to go into safe operation.

## Adding password protection

To allow only authorized personnel to modify the LWT configuration, and therefore the safety function behavior, password protection must be added:

- 1** From the **Device Setup** menu, select **Access Control > Advanced Password**.
- 2** In the password edit screen, edit each password character.
- 3** Press **OK**.
- 4** Repeat steps 1 to 3 for Standard Password instead of Advanced Password.

## Enabling/Disabling the write protection

The device shall be write-protected for the safety operation. This could be performed through the following steps:

- 1** Remove the nameplate by releasing the holding screw lying on the bottom left corner.
- 2** Use a suitable screwdriver to press the switch down fully.
- 3** Turn the switch clockwise by 90°.

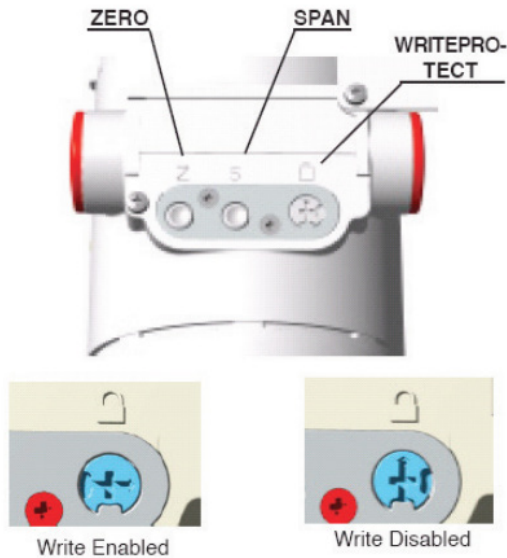

To deactivate the switch and remove the write protection, push it down slightly and turn 90° counterclockwise.

## Verify safety function

- 1 Verify and record the conditions as they are found prior to checking the safety function: write protection is on/off, instrument parameters.
- 2 Disable write protection before power up.
- 3 Check the current out precision by simulating current out and measure it with a multimeter. This could be performed by using an EDD/DTM interface or the HMI. The current out test shall test at least 4 mA and 20 mA.
- 4 Enable write protection and power down. If no alarm is issued after system startup, then the safety function is ensured during run-time.

**Page intentionally left blank**

# Operation and maintenance

## Proof test

In accordance with IEC 61508, the safety function of the measuring device must be checked at appropriate time intervals. The operator must determine the proof test interval and take this into account when determining the  $PFD_{AVG}$  value of the guided wave level transmitter. The test must be carried out in such a way that it verifies correct operation of the device.

Testing of fixed output current, HIGH and LOW alarm output current and measuring accuracy are covered in the proof test. Testing of the device can be performed by following the steps described below.

## Testing the instrument

To check the safety function of the device, proceed as follows:

- 1** Verify and record the conditions found prior to checking the safety function: write protection is on/off, instrument parameters, warning messages and error messages.
- 2** Bridge the safety DCS or take other appropriate measures to prevent inadvertent triggering of alarms.
- 3** Remove the instrument from its installation flange. Perform a visual inspection and record any visible defects or wear outs.
- 4** Deactivate write protection (see “Enabling/Disabling the write protection” on page 18).
- 5** Performing the proof test requires the specified voltage input (see “Alarm response and current output” on page 12) in series with an ammeter (see Figure 2).

**Figure 2** LWT current measurement

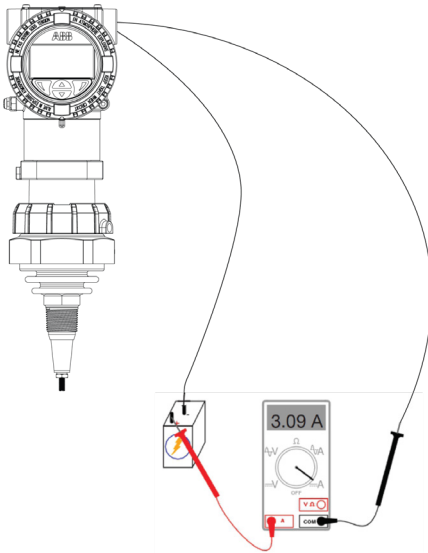

- 6 Set the transmitter output to a HIGH ALARM value by means of the HMI push buttons, HART communication by using a DTM in combination with HART software, or with the Field Information Manager (FIM-Tool) using simulation function (menu: **Diagnostics>Simulation Mode>Current Out**).
- 7 Check whether the current output signal reaches the value set for high alarm value.
- 8 Set the output of the transmitter to a LOW-ALARM value by means of the push buttons of the HMI, HART communication by using the LWT DTM or with the Field Information Manager tool (FIM-Tool) using simulation function (menu: **Diagnostics>Simulation Mode>Current Out**).
- 9 Check whether the current output signal reaches this value.
- 10 Terminate the simulation mode once the output simulation is finished.
- 11 Activate the write protection (see “Enabling/Disabling the write protection” on page 18) and wait for 10 seconds.
- 12 Restart the device by powering it off and back on.
- 13 Check the measured distance or ullage against a secondary standard on an installed device which could be a calibrated reference device, a mobile calibration rig or on a factory calibration rig. The measured values of the secondary standard and the device under test (DUT) must be compared. The amount of deviation between the measured distance, ullage and the set point must not exceed the measured error specified for the safety function ( $\pm 0.32$  mA).
- 14 Remove the bridging of the safety DCS or restore normal operation in another way.
- 15 After the test has been performed, the results must be documented and stored in a suitable manner. By using this test method at least 80.9 % (PTC = 0.809) of dangerous, undetected failures are detected. The influence of systematic errors (e.g., medium properties, operating conditions, build-up or corrosion on the safety function) is not fully covered by the test.

If one of the test criteria from the test procedure described above is not fulfilled, the device may no longer be used as part of a safety instrumented system.

## Possible error messages

If the LWT is malfunctioning in any way, the LCD displays specific error messages destined to help you identify and solve the problem. The chapter “Maintenance and Troubleshooting” of the user guide explains where the error summary appears and how to access the full details of the error.

CPU internal faults will result in the LOW alarm independent from the configured alarm current.

Readback faults for the 4–20 mA output will result in the LOW alarm for lower than expected current and HIGH alarm for higher than expected current, independently from the configured alarm current.

Other failures will be immediately signaled within the LOW or HIGH alarm range in line with the configured alarm current.

## Maintenance

The LWT should have its coupler and probe inspected and cleaned when the proof test is performed (as described in “Proof test” on page 21). No other maintenance is planned.

## Repair

To maintain safety operation, repairs must be performed by ABB after the instrument is taken out of service. Replacing modular components by original ABB spare parts is permitted if personnel was trained by ABB for this purpose.

Before sending the unit to ABB, it must be cleaned and decontaminated. ABB must be contacted to obtain the Contamination Data Sheet. After filling out and sending the contamination datasheet to ABB, an RMA number will be issued; after those steps the unit can be sent to ABB for repair.

Refer to the user guide for further details.

## Software updates

Software updates, if applicable and recommended by ABB, must be performed by ABB-trained personnel after the instrument is taken out of service.

## Useful life

The applied failure rates of the components are valid within the usable service life (8 to 12 years) according to IEC 61508-2 section 7.4.9.5, note 3, and start increasing after this period.

## ABB notification

All detected failures that compromise functional safety shall be reported to ABB. Contact ABB customer service as described in “Support” on page 7.

**Page intentionally left blank**



# Document status

## Change record

Version	Date	Change Description
A	01 March 2019	Initial release
B	27 August 2019	Modification to alarm delay values
C	18 December 2019	Updated to fix infrequent missed frames between internal electronic modules observed on some instruments. Updated software for compatibility with Hardware Revision 19.09.30.

## IEC-61508 certificate

**Page intentionally left blank**





---

**ABB Inc.**  
**Measurement & Analytics**

3400, rue Pierre-Ardouin  
Québec (Québec) G1P 0B2  
Canada

**Phone:**  
North America: 1 800 858 3847  
Worldwide: +1 418 877 2944

**Fax:**  
+1 418 877-2834

**E-mail:**  
level.support@ca.abb.com

**Web:**  
<https://new.abb.com/products/measurement-products/level/guided-wave-radar-level-transmitters/LWT>

---

We reserve the right to make technical changes or modify the contents of this document without prior notice. With regard to purchase orders, the agreed particulars shall prevail. ABB does not accept any responsibility whatsoever for potential errors or possible lack of information in this document.

We reserve all rights in this document and in the subject matter and illustrations contained therein. Any reproduction, disclosure to third parties or utilization of its contents—in whole or in parts—is forbidden without prior written consent from ABB.

© ABB, 2019