



Making the switch

ABB's new multiservice multiplexer, FOX615, meets the new challenges faced by operational communication networks

MATHIAS KRANICH, RAMON BAECHLI, HIMANSHU TRIVEDI – Utilities in electricity, oil and gas, mining, railways, etc. are optimizing their operations with constant reference to real-time data. To obtain these data, they must have access to extremely fast and reliable communication networks. Up to now they have relied on circuit-switched technology to transmit process data to control systems and operators enabling them to keep processes running smoothly. With growing numbers of packet-switched applications, utilities have to deal with new requirements for their communication infrastructure. ABB's answer to this is the FOX615, a multiservice multiplexer providing a unique combination of SDH (circuit-switched) and Ethernet (packet-switched) functionality, with additional utility-focused features and broadband communication facilities of up to 10 Gbit/s. With its high integration level and flexibility, FOX615 is suitable for a wide variety of applications and an ideal solution for utility communication networks.

1 Comparison of circuit switching and packet switching

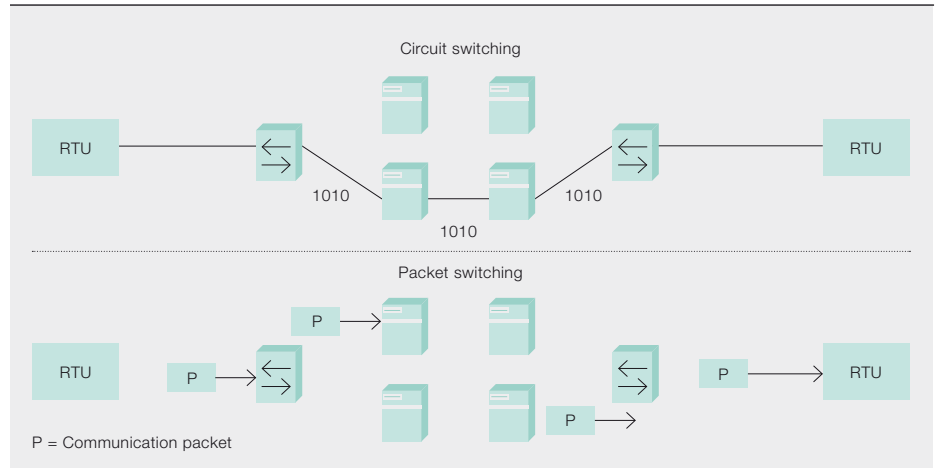

Industrial applications (eg, smart grids) and public telecommunications (eg, mobile high-speed Internet) depend on reliable communication networks. In the past, the wide-area networks (WAN) of public telecom operators and operational networks of utilities were based on the same circuit-switched PDH/SDH¹ technology, which provided the necessary performance level for both segments. Then came the rapid growth of data traffic caused by the switch from simple voice communication to triple-play applications of voice, data and video. To accommodate this change, public telecommunication networks moved to pure packet-switched WANs. An example of such a technology is Ethernet, which was extremely successful in local area networks (LANs) and telecom operators implemented similar solutions for WANs.

However, a connection-less, packet-switched technology does not inherently guarantee the same quality of service as SDH provides. Therefore, utilities stuck to the proven qualities of SDH technology to meet the more stringent requirements for their critical operational networks.

The connection-oriented framework of SDH can generate application-specific communication channels with short and

deterministic delay times, as well as low jitter. Packet-switched technology is based on queuing mechanisms, which introduce an additional delay and jitter while allowing variable bandwidth allocation. This makes it ideal for data traffic (eg, computer traffic) → 1. If the different communication technologies are considered in terms of automobile traffic, SDH provides discrete channels for each application, analogous to dedicated lanes for buses, emergency vehicles and other vehicles. Ethernet, by contrast, uses all lanes for all applications, which makes best use of the available infrastructure, but can not guarantee free lanes for high priority traffic. In order to bring some of the benefits of circuit-switched networks to packet-switched networks, various extensions of the original protocols have been developed. These include some of the most important protocols such as IP/MPLS², MPLS-TP³, and PBB⁴.

However, even with the new protocols, the quality of service delivered by packet-switched technologies, especially for use in electrical utility applications, remained insufficient. Because of the growing number of Ethernet-based applications and expected future progress in packet-switched technology, utilities now need to incorporate both technologies. They must accommodate the needs of real-time TDM applications (eg, protection) and packet-switched applications (eg, video surveillance, intranet). This means that devices used in the networks must also cater to both technologies, and that is exactly what ABB's hybrid multiplexer, the FOX615, does.

ABB's fundamental aim when designing the FOX615 was to produce a multiplexer that would fulfill the needs of real-time utility applications, while avoiding all technology-imposed performance constraints. To do so, they needed to combine a complete understanding of how future-proof communication networks need to be designed and to identify all of the utility-specific challenges that might arise.

Communication for utilities

Communication networks represent a utility's nervous system. While public telecom companies focus on providing communication services to millions of end-customers, utilities use communication networks to ensure the reliability of their processes. Unlike public telecoms, utility infrastructure is generally a long-term investment, where demand on communication channels is relatively static, comprising high availability (eg, 99.999 percent), coupled with a variety of application-specific requirements, eg, low jitter (for differential protection in electrical grids [1], tolerance of dusty environments (eg, in mining) or high avail-

Title picture

FOX communication cabinets in ABB factory workshop in Baden, Switzerland.

Footnotes

- 1 Plesiochronous Digital Hierarchy/Synchronous Digital Hierarchy. In North America Sonet is used as equivalent technology to SDH.
- 2 IP/MPLS: Internet Protocol/Multiprotocol Label Switching
- 3 MPLS-TP: Multiprotocol Label Switching-Transport Profile
- 4 PBB: Provider Backbone Bridging

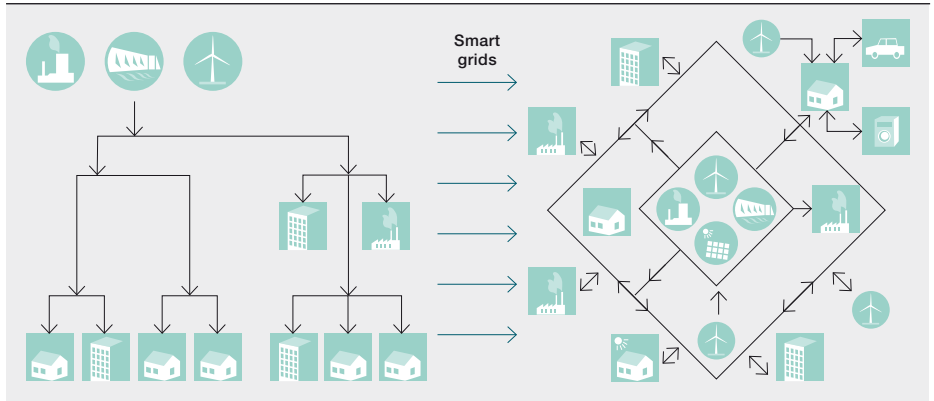

In traditional markets energy flow is from power generation to consumers. Smart grids are based on multidirectional power flows in a meshed network.

ability (eg, in railway control systems to ensure passenger safety) [2].

Investment cycles in utilities are much longer than those in the public telecom

network tends to be operated by relatively small teams of generalists (not communication specialists), who are responsible for large numbers of products and specialized functions. Operational

excellence for these networks can be ensured by implementing user-friendly and intuitive tools, all combined with a powerful, centralized network management system.

Utility networks evolve slowly, increasing in size and migrating to new technology step by step.

sector. Protection and control equipment in electrical substations, which is ultimately connected to utility communication equipment, is particularly long-lived. This means that legacy type interfaces need to be provided for many years more and the completely Ethernet/IP-based substation is still in the future.

Instead of the full network refurbishments often seen in public telecommunications networks, utility networks evolve slowly, increasing in size and migrating to new technology step by step. This evolution means that high interoperability between old and new installations is an absolute must.

Operational communication networks play an essential role in a utility's operations, but they are not the utility's main business and are therefore considered a supporting function. In other words, an electrical utility is in the business of supplying power. While absolutely essential, a well-functioning communication network simply helps to run that business. This means that a utility's communication

This is what FOX615 offers with its management software FOXMAN.

Utility environment challenges

Utility communication equipment used for operational networks is generally installed in the field and is exposed to harsh environmental conditions, ranging from extreme temperatures to magnetic and electrical fields, which can be particularly severe during short-circuit events. In order to maintain the high levels of availability required, especially in emergency situations, utility communication equipment must be extremely durable and reliable. In dusty and remote environments, where regular maintenance cannot be guaranteed, fan-less designs are preferable.

Electrical utility requirements

Teleprotection is one of the most demanding applications for telecommunications systems in the electrical utilities sector. When short circuits occur on power lines, it is absolutely essential that the fault is cleared within tens of milliseconds. That means the maximum com-



ABB's new FOX615 can bundle up to 32,000 channels on a single optical fiber link.

munication delay, from one end of the system to the other, must be less than 10 milliseconds. Additional requirements for this sector include symmetrical communication delay times, redundant channel routing, with bidirectional switching and restricted signal jitter [3]. If the application fails to operate correctly (ie. too slowly or not at all), the negative impact in terms of outages and financial losses could be enormous. This is why protection applications are among the most significant in the grid and require com-

Supervising the power grid via SCADA⁵ is another core requirement of utilities. Grid performance depends on the operator's ability to access accurate, real-time data on the status of the network. Network availability is essential for reliable operations and therefore sophisticated redundancy schemes using different redundancy protocols, are needed at various levels. Since power grids are large installations built up over a number of years, communication demands will differ significantly from substation to substation, depending on the devices used at the time of construction.

The fundamental aim when designing the FOX615 was to produce a multiplexer that would fulfill the needs of real-time utility applications, while avoiding all technology-imposed performance constraints.

munication systems with real-time performance and the highest levels of availability. Packet-switched Ethernet technology cannot inherently provide the necessary performance for these applications.

Grid challenges of utilities

Electrical utilities in particular face enormous changes, driven by demand for smart grid applications. Renewable power generation, more efficient power transmission and automated distribution infrastructure are being installed to meet the increasing demand for power and to comply with environmental legislation. These changes lead to multidirectional power flows, which require reliable, real-time communication to maintain grid stability → 2.

In addition to growing technical complexity, intensified competition and market deregulation in the power sector have led to increased pressure to reduce cost. Capital expenditure (CAPEX) can be optimized and investments protected by an extendable multiservice communication network, covering all requirements for the operation. Furthermore, operational

Footnote

5 SCADA: Supervisory Control and Data Acquisition

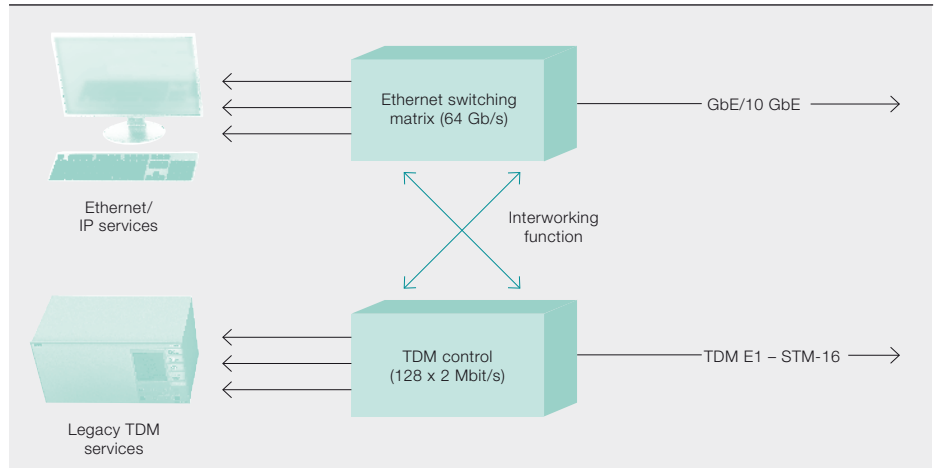

FOX615 combines TDM (PDH/SDH) and Ethernet/IP functionality: integrated TDM cross-connect (bottom) as well as Gigabit-Ethernet switching matrix (top).

The integrated access and transport multiplexer function significantly lowers OPEX and space requirements.

expenditure (OPEX) can be lowered by using less equipment in the system, which results in less operational and maintenance work.

FOX – a success story

ABB introduced the first fiber-optic multiplexer (FOX) more than 30 years ago and has since developed it into a full-fledged communication platform. While the first FOX product (FOX6) was a pure time division multiplexing (TDM) communication node with up to six channels, ABB's new FOX615 can bundle up to 32,000 channels on a single optical fiber link – this is equivalent to an annual bandwidth growth rate of 33 percent over the past 30 years.

FOX615 provides the perfect combination of traditional TDM (PDH/SDH) technology and sophisticated Ethernet/IP⁶ features to meet all the requirements of utilities. It can be easily integrated into existing PDH/SDH infrastructure, enabling step-wise migration and investment protection → 3.

In contrast to many other solutions, FOX615 views PDH/SDH and Ethernet/IP as complementary technologies, providing a perfect solution for real-time as well as packet-switched based applications. Supporting both TDM and packet-switched technologies in a single device is what allows the user to set up an SDH network that fulfills all performance requirements without needing to replace the communication equipment, and migrate to packet-switched solutions at a later stage. Full migration can be done when the necessary quality of service has been proven. FOX615 provides a powerful switching engine for packet-based communication, as well as a two-stage cross-connect for traditional TDM (PDH/SDH) signals → 4.

In addition, the integrated access and transport multiplexer function significantly lower OPEX and space requirements; only a single platform with sparse wiring needs to be installed and maintained → 5. Integrated access and transport also makes the management of the communication network easier since all alarms report directly to a single network management system. This ensures easy fault detection and the fastest reaction times.

The FOX615 multiplexer is a utility-grade communication product, capable of operating in electromagnetically polluted environments and across broad temperature ranges (–25°C to 60°C). Very high

Footnote

6 Internet Protocol (IP) allows logical structuring of data networks.

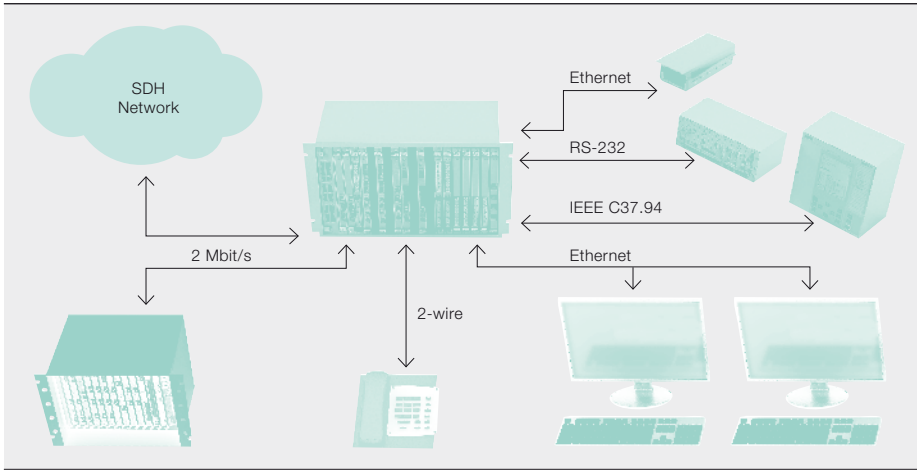

FOX615 multiservice node: Different user interfaces can be directly connected to the SDH communication backbone.

MTBF (mean time between failure) figures and exhaustive redundancy options ensure system availability. For a maintenance-free system, FOX615 is also available in a fan-less version.

Applications for electrical utilities

FOX615 is a multiservice multiplexer, which allows direct connection of all utility-specific applications to the multiplexer without external converter boxes. This includes direct connection of distance- and differential- protection relays. A specific interface for protection command signals, including specific functionality such as channel supervision, event recorder or fast protection switching, is available. For optical interconnection to the protection relay an IEEE C37.94 optical interface is available. This enables an all-optical interconnection to be made from relay to relay using the FOX615 multiplexer, reducing the use of fibers and providing enhanced availability through redundant channel routing. FOX615 enables real multiservice networks to be established with protection functions included as an integrated service.

FOX615 is a well-adapted platform providing a vast number of WAN and application interfaces, including teleprotection. Its rugged design with enhanced management functionality ensures long lifetime and easy maintenance.

With FOX615, utilities are not under pressure to change to new, not yet utility-proven technologies. Established technologies will continue to be sup-

ported for many years. Migration to new technologies will be possible by upgrading installed FOX615s. ABB is constantly analyzing upcoming communication standards and technologies to assess their applicability for utilities. Future releases of FOX615 are already planned and will enhance FOX615's quality of service for utility WAN implementations using packet-switched technologies.

FOX615 can be easily integrated into existing PDH/SDH infrastructure, enabling step-wise migration and investment protection.

Mathias Kranich

Ramon Baechli

ABB Power Systems
Baden, Switzerland
mathias.kranich@ch.abb.com
ramon.baechli@ch.abb.com

Himanshu Trivedi

ABB Management Services Ltd.
Zurich, Switzerland
himanshu.trivedi@ch.abb.com

References

- [1] H.Spiess, R.Comino, M.Kranich, Transmission of mission-critical information for power utility's operational needs, Juko-CIGRE, 2004, Becici, Montenegro
- [2] Jaime, Lloret, Francisco Javier Sanchez, Hugo Coll, and Fernando Boronat, Can Critical Real-Time Services of Public Infrastructures Run over Ethernet and MPLS Networks? NETWORKING 2008, 7th International IFIP-TC6 Networking Conference, Singapore, May 2008
- [3] CIGRE Joint Working Group 34/35.11, Protection using Telecommunication, 2000, Table 6.1-1 & 6.1-2