

Wasserversorgung Oberstdorf, Oberstdorf, Germany

Cost efficient upgrade from ABB SattCon to Freelance Process Control System



Customer and application

Wasserversorgung Oberstdorf (WVO) is the local water supplier for the region Oberstdorf in Southern Germany. WVO is producing, distributing and trading drinking water to 2,400 private and commercial connections, supplying water to almost 10,000 inhabitants in the region. The drinking water comes from five deep wells and is without any further treatment pumped into nine high-level tanks with a capacity of 4,160m³ for distribution. The length of the pipeline is about 135 km in total. The total consumption of water per year is approx. 1,1 Mio m³.

Freelance Control System

To control the five wells and the nine high-level tanks for appropriation of the water to the distribution network, an ABB SattCon control system has now been migrated to Freelance Control system with AC 700F controllers. The system consists of eleven AC 700F controllers with approx. 50 direct I/O points per controller installed remotely with an Ethernet-connection at the pump rooms and high-level tanks. Panels 800 are used for visualization and control on-site. Each panel also has access to the whole project. Five operator stations and one engineering station are located in the central control room. An OPC-connection allows SMS-Alerting as well as checking the water levels in the high-level tanks. Furthermore, there is a connection to ACRON-Software. This software is a standard for recording, long-term archiving and analysis of operational data in the water industry.

Local support by channel partners

Channel partner Albrecht elektrotechnik from Immenstadt, Southern Germany, was responsible for the engineering, project execution and implementation of this project. After successful completion of a Freelance training course, an engineer from Albrecht was able to program the application by himself – though he had never worked with the Freelance system before. The easy-to-learn and intuitive configuration of the Freelance system with a single engineering tool – Control Builder F – was a crucial factor for WVO to chose ABB's control system.

“Control Builder F” simplifies commissioning and maintaining of the entire application. The configuration is particularly simple as the visualization is also created with Control Builder F. Separate tools for programming the PLCs and to create operator images are no longer needed. Future modifications can be done by the System integrator's engineer. Start-up went smoothly – there were no significant issues.

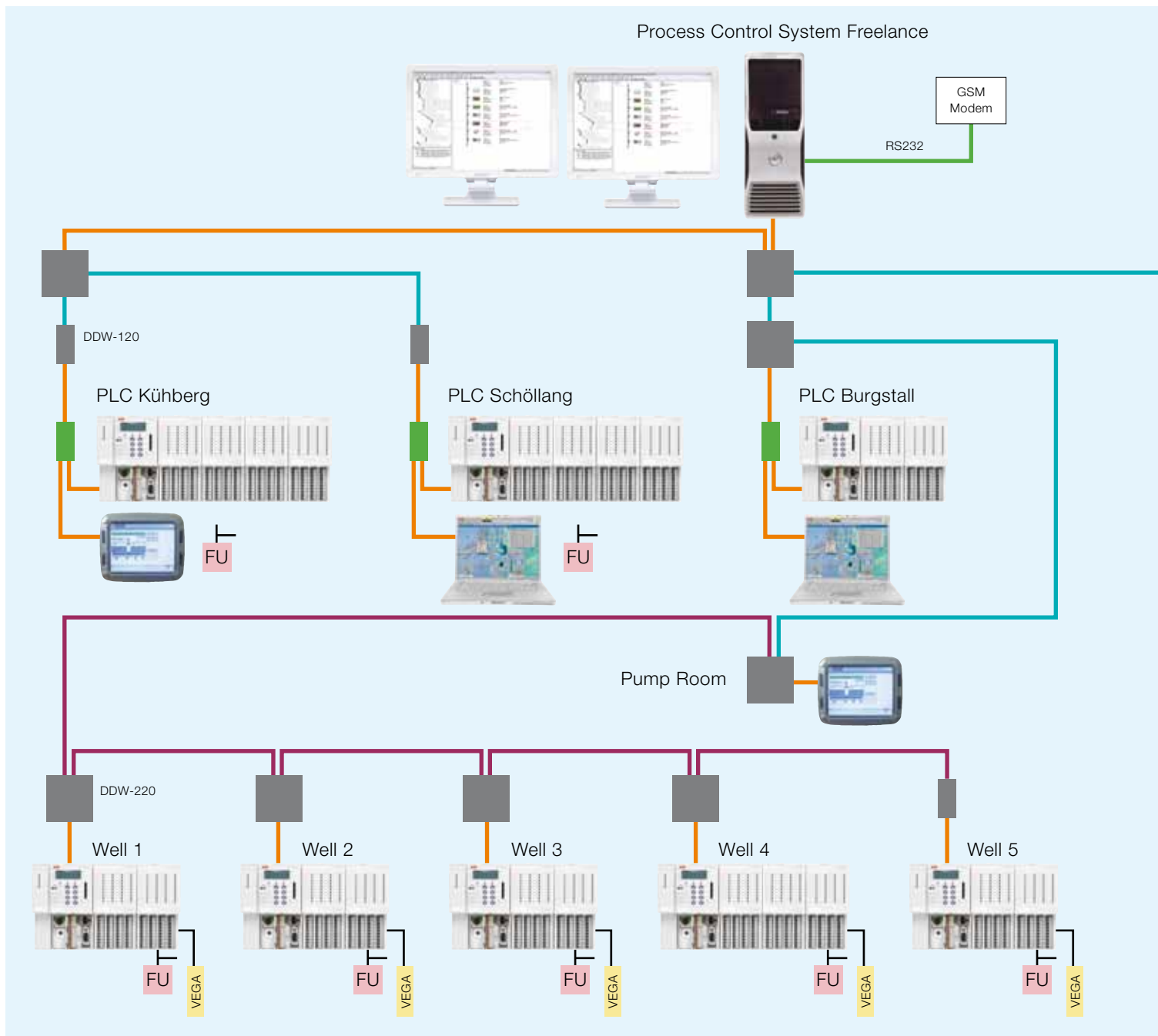

Customer Quotes

“The advanced control system technology was one important fact for our customer WVO to choose the Freelance system. Compared to the PLC-solution, a process control system offers more functionality, for example automatically generated diagnostic information and alarms as well as easy and fast online optimizations of applications. The integrated control system solution allows for always up-to-date, automatically generated graphical documentation of the entire user program, system communication and all field device parameters. In addition,

simplified remote diagnostics in central control rooms is possible, as the control technology automatically generates system alarms and system diagnostics, which are available using PC technology”, states project leader Christian Kamp from Albrecht elektrotechnik. “The uniform tool for configuring the controller and the operator station with automatically generated faceplates (operator windows) saves time for engineering and commissioning. Time can also be saved in ongoing operation and for maintaining the application thanks to advanced diagnostics opportunities and improved alarm handling.”

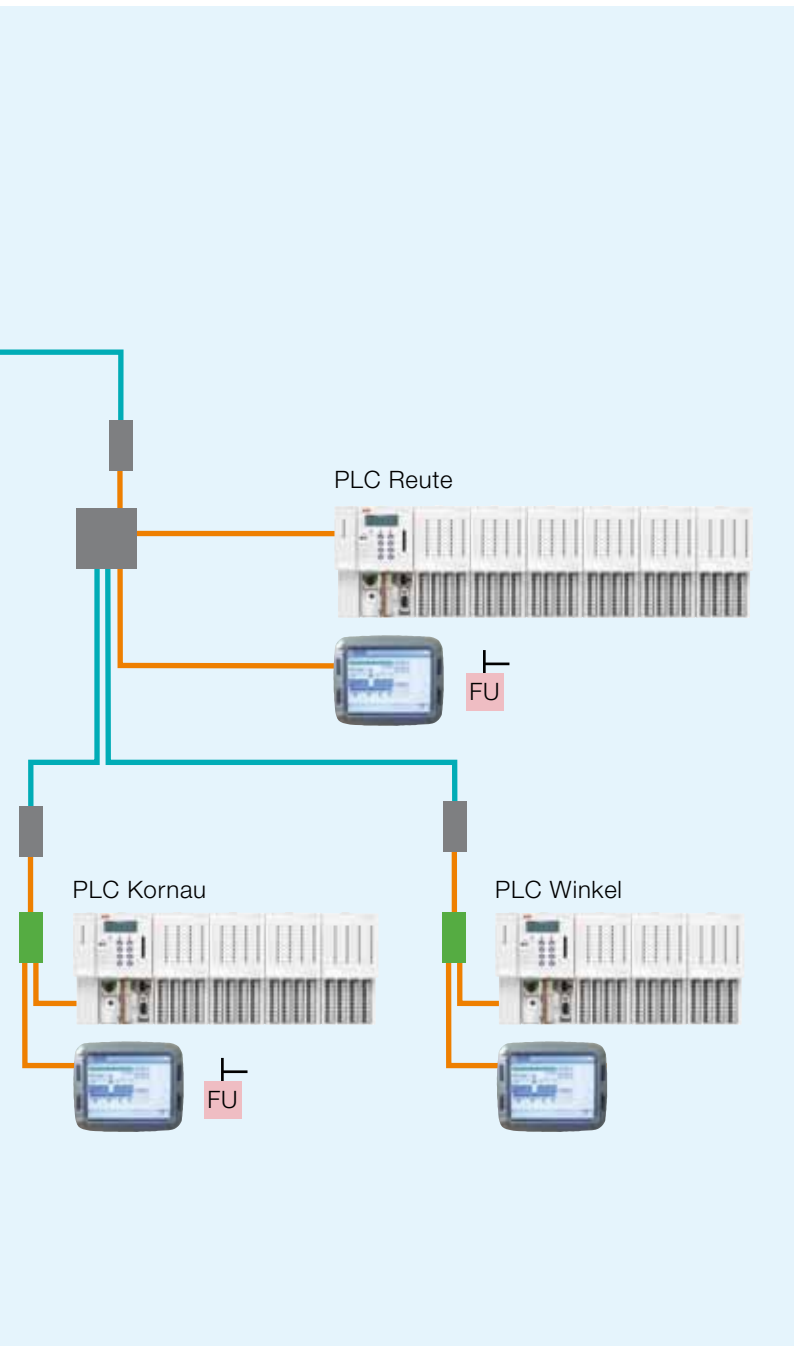

Contact us

ABB Pte Ltd

Open Control Systems

Singapore

Phone: +65 6776 5711

Fax: +65 6778 0222

E-mail: processautomation@sg.abb.com

www.abb.com/controlsystems

ABB Automation LLC

Open Control Systems

Abu Dhabi, United Arab Emirates

Phone: +971 (0) 2 417 1333

Fax: +971 (0) 2 626 3230

E-mail: processautomation@ae.abb.com

www.abb.com/controlsystems

ABB AB

Open Control Systems

Västerås, Sweden

Phone: +46 (0) 21 32 50 00

Fax: +46 (0) 21 13 78 45

E-mail: processautomation@se.abb.com

www.abb.com/controlsystems

ABB Inc.

Open Control Systems

Wickliffe, OH, USA

Phone: +1 440 585 8500

Fax: + 1 440 585 8756

E-mail: industrialitsolutions@us.abb.com

www.abb.com/controlsystems

ABB Automation GmbH

Open Control Systems

Mannheim, Germany

Phone: +49 (0) 1805 26 67 76

Fax: +49 (0)1805 77 63 29

E-mail: marketing.control-products@de.abb.com

www.abb.de/controlsystems

Note:

We reserve the right to make technical changes or modify the contents of this document without prior notice. With regard to purchase orders, the agreed particulars shall prevail. ABB does not accept any responsibility whatsoever for potential errors or possible lack of information in this document.

We reserve all rights in this document and in the subject matter and illustrations contained therein. Any reproduction, disclosure to third parties or utilization of its contents – in whole or in parts – is forbidden without prior written consent of ABB.

© Copyright 2010 ABB.

All rights reserved.