



  
BUYLOG SECTION 20

# Surge Protection Devices



# Table of contents

	<b>Surge protection devices</b>		
20-4	Introduction	20-32	<b>OVR RS485Q and SL RS485 series</b>
20-5	ReliaGear® RGWMSP Series SPD	20-34	Product range overview
20-6	ReliaGear® RGMESP Series SPD	20-36	OVR Q series
20-7	Dimensions	20-38	OVR SL series
		20-39	OVR SL RS485 and OVR RS485Q series dimensions
			OVR Q and OVR SL series dimensions
	<b>OVRH series</b>		
20-8	Product range overview		<b>DIN-rail SPDs for distribution panels - UL 1449 4th edition</b>
20-9	OVRHTP (4,000A and below, 60 to 100kA)	20-40	Overview
20-11	OVRHTP (4,000A and below, 120 to 200kA)	20-41	Terminology of SPD electrical characteristics
20-13	OVRHTP (4,000A and below, 240 to 400kA)	20-42	Standards
20-15	OVRHT3D (400A and below, 50kA)		
20-16	Dimensions		
20-20	OVRHMSU series-connected suppression filter system	20-44	<b>Protection block assembly</b>
	<b>OVRT2 series</b>		
20-22	Selection guide		
20-23	Product range overview		
20-24	OVRT2 single-pole		
20-25	OVRT2 1N		
20-26	OVRT2 2L		
20-27	OVRT2 2N		
20-28	OVRT2 2L		
20-29	OVRT2 3N		
20-30	Dimensions		

---

## Surge protection devices

### Introduction

Surge Protection Devices (SPDs) are designed to protect against transient surge conditions.

Transient surges can reach values of hundreds of thousands of volts or instantaneous current flow of tens of thousands of amperes, but typically last less than one hundred microseconds in duration.

Transient surges generated within a facility typically account for 80% of the surge activity.

These internally generated transients can be caused by switching power supplies (computers), electronic ballasts (building lighting) and variable frequency drives (air handlers, elevators, etc).

The most destructive transient voltage surges can be attributed to lightning and utility load switching; however, experts predict that these two events account for 20% of all transient surge activity.

Reliable data sources suggest that lightning strikes have current magnitudes in excess of 200,000 amps. Moreover,

lightning strikes are not single strike events. Strikes typically consist of four to six "hits" and sometimes can be as high as 40kA.

Therefore, SPDs must be appropriately sized to provide adequate protection during multiple surge events.

Large transient surge conditions can damage printed circuit board traces and puncture semiconductors causing immediate or intermittent equipment failures. Continued exposure to surges can degrade printed circuit board traces or semiconductors resulting in seemingly random delayed equipment failures. Therefore, equipment failures cannot always be contributed to a single power quality event. Surge remnants on data lines can alter digital data and logic levels causing equipment failures and lockups.

**Professionally installed ABB products provide superior protection against transient surges preventing unnecessary downtime and costly repairs.**

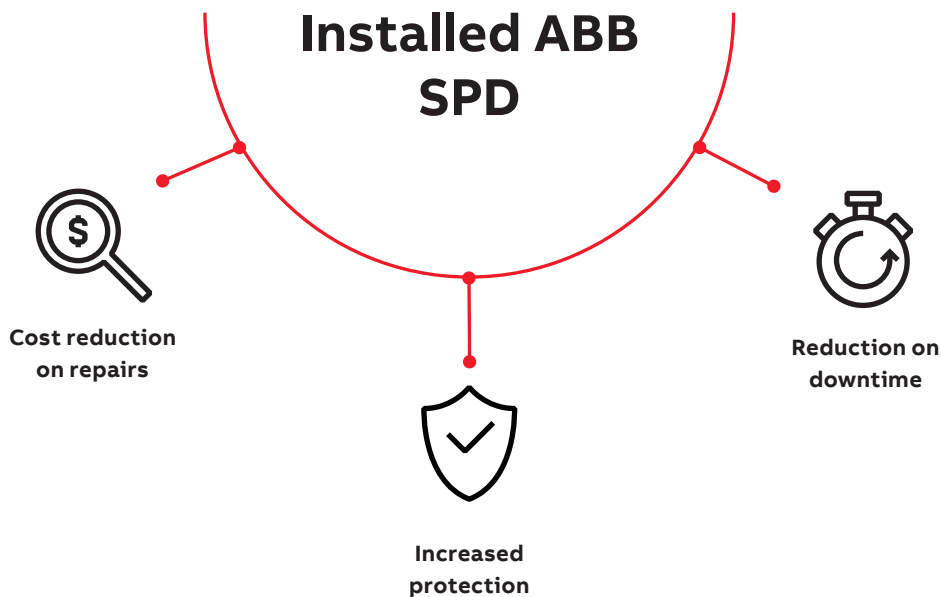

# ReliaGear Surge Protective Device RGWMSP



The ReliaGear® RGWMSP Series offers robust surge protection with an emphasis on performance, safe operation, and user-friendly diagnostics.

ReliaGear® RGWMSP Series SPDs are engineered with smart thermal disconnecting technology that safely removes over-stressed components before harmful external effects arise. This preventive approach enhances safety and avoids nuisance from OCPD tripping or thermal events.

\*For a full list of orderable products please visit this [resource](#)

	Voltage	Configuration	Part number
120S	240 / 120	1-phase, 3-wire + ground	RGWMSP120SXX**&&
120Y	208Y / 120	3-phase, 4-wire + ground	RGWMSP120YXX**&&
240D	240 Delta	3-phase, 3-wire + ground	RGWMSP240DXX**&&
240H	240 / 120 Hi-Leg Delta	3-phase, 4-wire + ground	RGWMSP240HXX**&&
277Y	480Y / 277	3-phase, 4-wire + ground	RGWMSP277YXX**&&
347Y	600Y / 347	3-phase, 4-wire + ground	RGWMSP347YXX**&&
480D	480 Delta	3-phase, 3-wire + ground	RGWMSP480DXX**&&
600D	600 Delta	3-phase, 3-wire + ground	RGWMSP600DXX**&&

Desired kA	XX Code
80 kA/mode   160 kA/phase	08
150kA/mode   160 kA/phase	15
225 kA/mode   450 kA/phase	22 - Only available on RGWMSP models with type 4 enclosure
300 kA/mode   600 kA/phase	30 - Only available on RGWMSP models with type 4 enclosure

Type	** Code
Type 2 SPD	T2
Type 1 SPD	T1
Enclosure	&& Code
NEMA 1	1
NEMA 1 with Disconnect	1D
NEMA 4 without Disconnect (Painted Steel)	4
NEMA 4 with Disconnect (Painted Steel)	4D
NEMA 4X stainless steel with Disconnect	XD

The core suppression system includes proprietary Metal Oxide Varistors (MOVs) for surge energy diversion and metal film capacitors for filtering low-level transient voltages and electrical noise. The design is UL Listed, suitable for all NEC compliant installations.

**Standards:**

- UL 1449 5th Ed. – Listed, —Mil-Std-220C
- UL 1283 Listed EMI/RFI Filter—ANSI/NFPA 70 (Art. 242)
- UL 96A – Meets SPD criteria—ANSI/IEEE C62.41 & .45
- cUL Listed to UL 1449 & CSA C22.2—ANSI/IEEE C62.62 & .7

Electrical characteristics	
Maximum surge current rating	80 kA per mode / 160 kA per phase 150 kA per mode / 300 kA per phase 225 kA per mode / 450 kA per phase 300 kA per mode / 600 kA per phase
Nominal discharge current rating (In)	20 kA
Operating frequency	50–60 Hz
Surge life (IEEE C62.41 - C3 10 kA )	≥5,000 impulses
Modes of protection	All modes (L-N, L-G, N-G, L-L)
Fault rating (SCCR)	200 kAIC
Standard monitoring	Tri-Color LED indicators per phase: Green LED normal operation, SPD componentry is compromised, Orange Service indicator alarm. Rotatable Color View LCD display. Phase loss indication. N-G Voltage Detection > 20V detected. Audible alarm w/ silence option. Dry Contacts: Remote dry (volt-free) relay contacts rated at (<2 A, 250Vac / 220Vdc)

EMI / RFI filter attenuation	
Maximum attenuation frequency	-61 dB at 100.2 kHz

Mechanical characteristics	
Weight	Varies and depends on enclosure type
Enclosure type	Varies on option chosen
Installation location	Service entrance equipment, primary distribution equipment
Mounting method	Surface mount, 4-point mounting brackets
Operating temperature	-40 °F to 149 °F (-40 °C to 65 °C)
Altitude	< 13,000 ft (datasheet value based on C&C calculations)
Product design	Individually fused thermally protected MOV technology

Regulations and certifications	
UL 1449 5th edition	Type 1 / Type 2
cUL, CSA C22.2	Type 1 / Type 2
UL 1283	Type 1 / Type 2
UL 96A	Type 2
cUL Listed to UL 1449 & CSA C22.2—ANSI/IEEE C62.62 & .72	Yes
IEC 61643-11	Yes
Listed by	UL

## ReliaGear Surge Protective Device

### RGMESP



ReliaGear® RGMESP Series SPDs are engineered with smart thermal disconnecting technology that safely removes overstressed components before harmful external effects arise. This preventive approach enhances safety and avoids nuisance from OCPD tripping or thermal events.

The core suppression system includes proprietary Metal Oxide Varistors (MOVs) for surge energy diversion and metal film capacitors for filtering low-level transient voltages and electrical noise. The design is UL Listed, suitable for all NEC compliant installations.

#### Standards:

- UL 1449 5th Ed. – Listed, —Mil-Std-220C
- UL 1283 Listed EMI/RFI Filter—ANSI/NFPA 70 (Art. 242)
- UL 96A – Meets SPD criteria—ANSI/IEEE C62.41 & .45
- cUL Listed to UL 1449 & CSA C22.2—ANSI/IEEE C62.62 & .7
- IEC 61643-11

\*For a full list of orderable products please visit this [resource](#)

	Voltage	Configuration	Part number	
	120S	240 / 120	1-phase, 3-wire + ground	RGMESP120SXXT2
	120Y	208Y / 120	3-phase, 4-wire + ground	RGMESP120YXXT2
	240D	240 Delta	3-phase, 3-wire + ground	RGMESP240DXXT2
	240H	240 / 120 Hi-Leg Delta	3-phase, 4-wire + ground	RGMESP240HXXT2
	220Y	380Y / 220	3-phase, 4-wire + ground	RGMESP220YXXT2
	240Y	415Y / 240	3-phase, 4-wire + ground	RGMESP240YXXT2
	277Y	480Y / 277	3-phase, 4-wire + ground	RGMESP277YXXT2
	480D	480 Delta	3-phase, 3-wire + ground	RGMESP480DXXT2
	<b>Desired kA</b>		<b>XX Code</b>	
	80 kA/mode   160 kA/phase			08
	100kA/mode   200 kA/phase			10

RGMESP wall-mount SPDs with enhanced thermal protection  
Dimensions

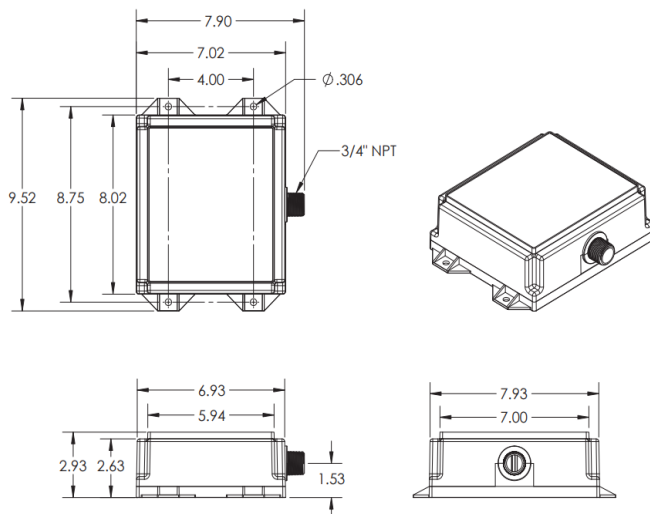

Electrical characteristics	
Maximum surge current rating	80 kA per mode / 160 kA per phase 100 kA per mode / 200 kA per phase
Nominal discharge current rating (In)	20 kA
Operating frequency	50–60 Hz
Surge life (IEEE C62.41 - C3 10 kA)	≥5,000 impulses
Modes of protection	All modes (L-N, L-G, N-G, L-L)
Fault rating (SCCR)	200 kA for all models
Standard monitoring	Status indicator lights (one per phase) Standard dry (form C) relay contacts Audible alarm
EMI / RFI filter attenuation	
Maximum attenuation frequency	-61 dB at 100.2 kHz
Mechanical characteristics	
Weight	5.1lb (2.3 kg)
Enclosure type	Polymer, UL 94 5VA polycarbonate, black. NEMA 4/ Type 4
Installation location	Service entrance equipment, primary distribution equipment – Rated for UL and NEC Type 2 installation locations
Mounting method	Dual mounting flanges / ¾" NPT offset nipple
Operating temperature	-40 °F to 149 °F (-40 °C to 65 °C)
Altitude	< 13,000 ft (3.96 km)
Product design	Thermal fuse technology
Regulations and certifications	
UL 1449 5th edition	Type 2
cUL, CSA C22.2	Type 2
UL 1283	Type 2
UL 96A	Yes
IEEE C62.62, C62.72	Yes
Listed by	UL

# RGWMSP Surge Protective Device

## Dimensions

### RGWMSP wall-mount SPDs with enhanced thermal protection

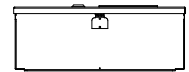
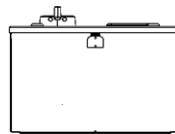
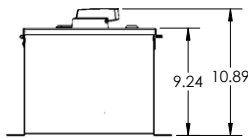
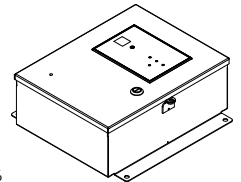
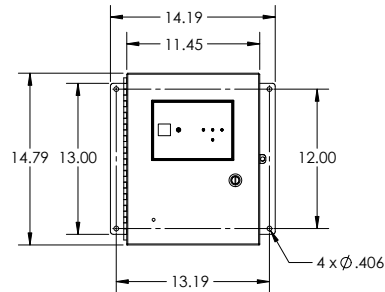
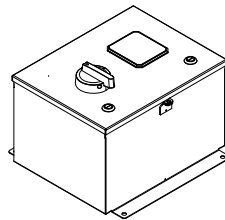
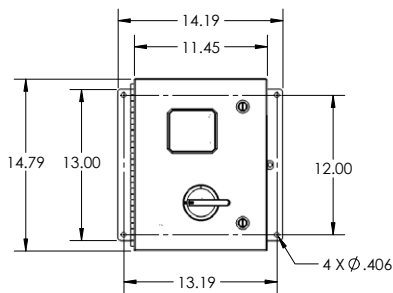

RGWMSP- NEMA 4 with disconnect SW dimensions

RGWMSP - NEMA 1 W/O disconnect SW dimensions

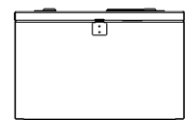
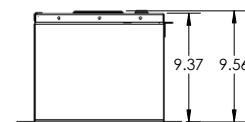
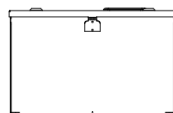
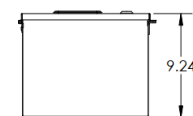
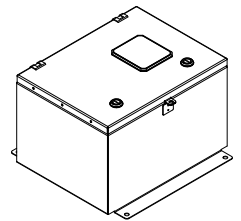
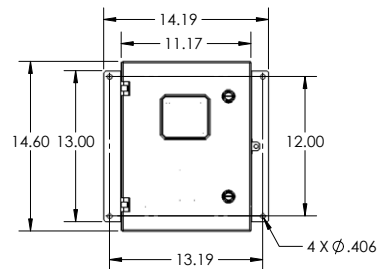
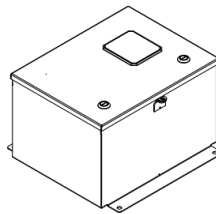
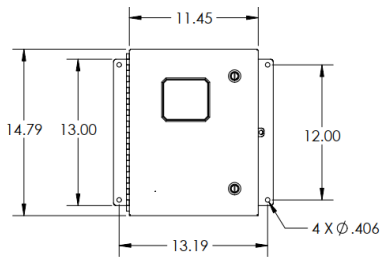

RGWMSP- NEMA 4 without disconnect SW dimensions

RGWMSP - NEMA 1 W/O disconnect SW dimensions

## OVRH series

### Product range overview



Name	OVRHTP (60, 120, 160, 200, 400)	OVRHMSU	OVRHT3D
Connection ampacity	4000 and below	24 A	400 A and below
SPD type	Type 1 and Type 2	Type 4 for Type 2	Type 1
Certifications	UL 1449	UL 1449	UL 1449
Surge ratings	60, 80, 100, 120, 160, 200, 240, 300, 400 kA per phase	50 kA per phase	50 kA per phase
LEDs	Yes	Yes	Yes
Dry relay contacts	Standard	Not available	Not available
EMI filter	Optional	Yes	Not available
Surge counter	Optional	Not available	Not available
Warranty	10 years	5 years	3 years



## OVRHTP series

### Product specifications

<b>Electrical</b>	
Maximum surge current rating	XX kA per phase, XX kA per mode
Nominal discharge current rating (In)	10 kA
Operating frequency	47–63 Hz
Connection method	Pre-wired with 36 inches of #10 AWG conductor
Modes of protection	All modes (L-N, L-G, N-G, L-L)
Fault rating (SCCR)	200 kAIC — no upstream over-current protection device (breaker or fuse) required
Application	ANSI/IEEE C62.41.1 locations A, B and C ideal for distribution panels, branch panels and critical loads

<b>Mechanical</b>	
Installation location	Indoor or outdoor
Mounting method	Dual mounting flanges
Operating environment	-40 °F to 149 °F (-40 °C to +65 °C) 5%–95% non-condensing humidity
Altitude	0–12,000 ft (3.66 km)
Product design	Individual thermally fused MOV technology

<b>EMI/RFI filter attenuation</b>	
Mil Standard 220B	Up to 40 dB from 10 kHz to 100 MHz

<b>Regulatory</b>	
cULus 1449 4th Edition	VZCA: E316636 Type 1
UL 1283 with filter option	Yes
UL96A compliant	Yes
IEEE C62.41.2, C62.45	Yes
NFPA 70 (NEC), Article 285	Yes
RoHs compliant	Yes
Listed by	UL

<b>Warranty</b>	<b>10 years</b>
-----------------	-----------------



## OVRHTP series

### Product specifications

<b>Electrical</b>	
Maximum surge current rating	XX kA per phase, XX kA per mode
Nominal discharge current rating (In)	20 kA
Operating frequency	47–63 Hz
Connection method	Pre-wired with 36 inches of #6 AWG conductor (P, M or S enclosure suffix) or termination lugs for #10–#4 AWG conductor (PL, ML or SL enclosure suffix)
Modes of protection	All modes (L-N, L-G, N-G, L-L)
Fault rating (SCCR)	200 kAIC — no upstream over-current protection device (breaker or fuse) required
Application	ANSI/IEEE C62.41.1 locations A, B and C ideal for distribution panels, branch panels and critical loads

<b>Mechanical</b>	
Installation location	Indoor or outdoor
Mounting method	Dual mounting flanges
Operating environment	-40 °F to 149 °F (-40 °C to +65 °C) 5%–95% non-condensing humidity
Altitude	0–12,000 ft (3.66 km)
Product design	Individual thermally fused MOV technology

<b>EMI/RFI filter attenuation</b>	
Mil Standard 220B	Up to 40 dB from 10 kHz to 100 MHz

<b>Regulatory</b>	
cULus 1449 4th Edition	VZCA: E316636 Type 1
UL 1283 with filter option	Yes
UL96A compliant	Yes
IEEE C62.41.2, C62.45	Yes
NFPA 70 (NEC), Article 285	Yes
RoHs compliant	Yes
Listed by	UL

<b>Warranty</b>	
	10 years



## OVRHTP series

### Product specifications

<b>Electrical</b>	
Maximum surge current rating	XX kA per phase, XX kA per mode
Nominal discharge current rating (In)	20 kA
Operating frequency	47–63 Hz
Connection method	Termination lugs for #10–#4 AWG conductor (PL, ML or SL enclosure suffix)
Modes of protection	All modes (L-N, L-G, N-G, L-L)
Fault rating (SCCR)	200 kAIC — no upstream over-current protection device (breaker or fuse) required
Application	ANSI/IEEE C62.41.1 locations A, B and C ideal for distribution panels, branch panels and critical loads

<b>Mechanical</b>	
Installation location	Indoor or outdoor
Mounting method	Dual mounting flanges
Operating environment	-40 °F to 149 °F (-40 °C to +65 °C) 5%–95% non-condensing humidity
Altitude	0–12,000 ft (3.66 km)
Product design	Individual thermally fused MOV technology

<b>EMI/RFI filter attenuation</b>	
Mil Standard 220B	Up to 40 dB from 10 kHz to 100 MHz

<b>Regulatory</b>	
cULus 1449 4th Edition	VZCA: E316636 Type 1
UL 1283 with filter option	Yes
UL96A compliant	Yes
IEEE C62.41.2, C62.45	Yes
NFPA 70 (NEC), Article 285	Yes
RoHs compliant	Yes
Listed by	UL

<b>Warranty</b>	<b>10 years</b>
-----------------	-----------------

## OVRH series

OVRHT3D (400 A and below, 50 kA)



### Product features

- UL listed 1449 5th edition for Type 1 SPD applications
- 50 kA per phase protection
- Individual thermally fused and protected MOVs
- Includes pre-wired pigtail conductors
- Multiple MOVs per phase eliminate single-point failure

Voltage	Network Type 1 SPD	Part number
240 V	1-phase, 2-wire + ground	OVRHT3D502401P
277 V	1-phase, 2-wire + ground	OVRHT3D502771P
240/120 V	2-phase, 3-wire + ground	OVRHT3D501202S
208/120 V	3-phase Wye, 4-wire + ground	OVRHT3D501203Y
380/220 V	3-phase Wye, 4-wire + ground	OVRHT3D502203Y
480/277 V	3-phase Wye, 4-wire + ground	OVRHT3D502773Y
240 V	3-phase Delta, 3-wire + ground	OVRHT3D502403D
380 V	3-phase Delta, 3-wire + ground	OVRHT3D503803D
480 V	3-phase Delta, 3-wire + ground	OVRHT3D504803D
<b>Special order</b>		
120 V	1-phase, 2-wire + ground	OVRHT3D501201P
220 V	1-phase, 2-wire + ground	OVRHT3D502201P
230 V	1-phase, 2-wire + ground	OVRHT3D502301P
347 V	1-phase, 2-wire + ground	OVRHT3D503471P
480/240 V	2-phase, 3-wire + ground	OVRHT3D502402S
400/230 V	3-phase Wye, 4-wire + ground	OVRHT3D502303Y
415/240 V	3-phase Wye, 4-wire + ground	OVRHT3D502403Y
600/347 V	3-phase Wye, 4-wire + ground	OVRHT3D503473Y
400 V	3-phase Delta, 3-wire + ground	OVRHT3D504003D
600 V	3-phase Delta, 3-wire + ground	OVRHT3D506003D
240/120 V	3-phase high-leg, 4-wire + ground	OVRHT3D502403H

Electrical	
Maximum surge current	50 kA per phase
UL type designation	Type 1
UL 1449 nominal discharge current rating (In)	20 kA
UL 1449 fault rating/short circuit current rating (SCCR)	200 kAIC

Design specifications	
Product design	Individual thermally fused and protected MOVs
Connection methods	External parallel connected for mounting next to electrical gear
Typical connection	18" #12 AWG (pre-wired pig tails)

Diagnostic and status monitoring specifications	
LED protection status monitoring standard	Status indicator light, 1 per phase

Enclosure	
Enclosure type	Polycarbonate, NEMA 4X
Installation location	Indoor/outdoor
Mounting method	12.7 mm (½") NPT side-mount nipple

Technical data	
Humidity range	0–95% non-condensing
Operating environment	-35 °C to +85 °C (-31 °F to +185 °F)
Operating frequency	50–60 Hz
Modes of protection	Model dependent

Size specifications	
Dimensions	4.25" × 2.41" × 2.75"
Weight	0.23 kg (0.5 lb.)

Standards compliance and certifications	
UL 1449 5th Edition: 2021, cULus, (UL File: VZCA E316636), ANSI/IEEE C62.41.1-2002, C62.41.2-2002, C62.420-2002, NEC Article 285	
ISO 9001: 2014 quality management system, ISO 17025:2007 laboratory certification (UL DAP program) compliance with RoHS, REACH and California Prop 65	
100% quality tested prior to shipping	

# OVRHTP series

## Dimensions

### Dimensions OVRHTP (60 to 100 kA)

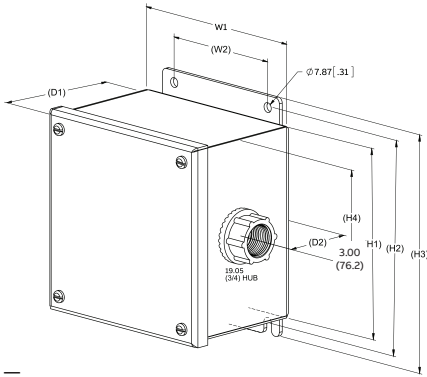

Metal enclosure

Value	Inches / Millimeters
H1	6.00 / 152.4
H2	6.75 / 171.5
H3	7.5 / 190.5
W1	6.00 / 152.4
W2	4.00 / 101.6
D1	4.26 / 108.3
D2	2.25 / 57.2

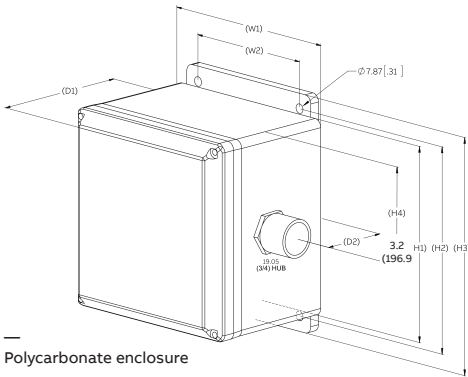

Polycarbonate enclosure

H1	6.42 / 163
H2	6.75 / 171.5
H3	7.75 / 196.9
W1	6.42 / 163
W2	4.50 / 114.3
D1	4.79 / 121.7
D2	2.25 / 57.15

### Dimensions OVRHTP (120 to 200 kA)

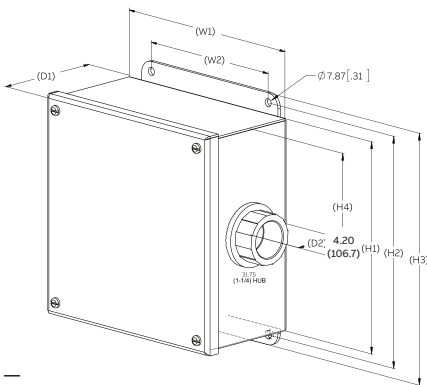

Metal enclosure pre-wired Enclosure option M

Value	Inches / Millimeters
H1	8.00 / 203.2
H2	8.75 / 222.3
H3	9.5 / 241.3
W1	8.00 / 203.2
W2	6.00 / 152.4
D1	4.26 / 108.3
D2	2.00 / 50.8

# OVRHTP series

## Dimensions

### Dimensions OVRHTP (120 to 200 kA)

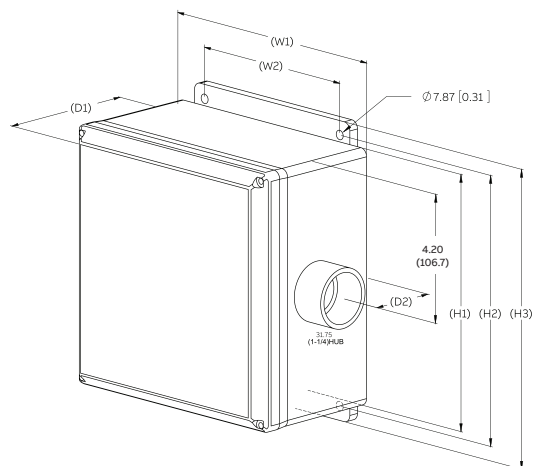

Polycarbonate enclosure pre-wired Enclosure option P

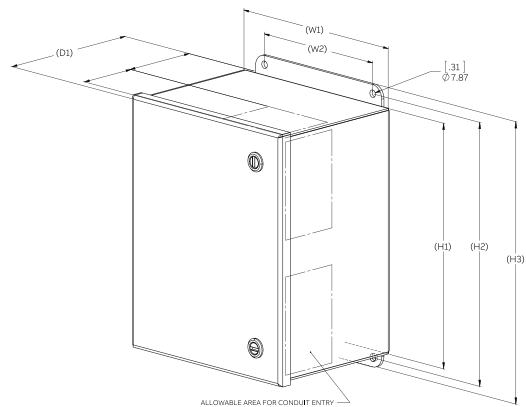

Metal enclosure with lugs Enclosure option ML

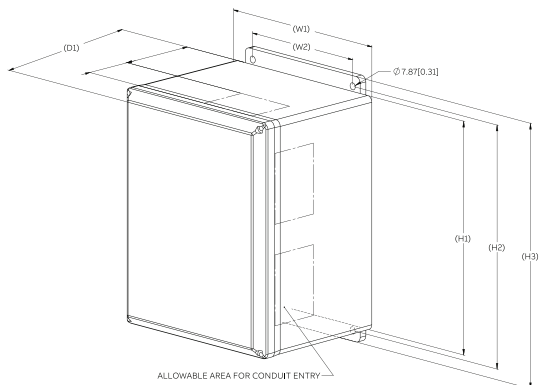

Polycarbonate enclosure with lugs Enclosure option PL

Value	Inches / Millimeters
H1	8.42 / 213.9
H2	8.84 / 224.4
H3	9.78 / 248.3
W1	8.42 / 213.9
W2	6.00 / 152.4
D1	4.79 / 121.7
D2	2.25 / 57.2
H1	10.00 / 254
H2	10.75 / 273.1
H3	11.5 / 292.1
W1	8.00 / 203.2
W2	6.00 / 152.4
D	6.26 / 159.1
H1	10.35 / 291.9
H2	10.75 / 273.1
H3	11.69 / 296.9
W1	8.35 / 212.1
W2	6.00 / 152.4
D	6.79 / 172.5

# OVRHTP series

## Dimensions

Dimensions OVRHTP (240 to 400 kA)		
<p>— Metal enclosure with lugs Enclosure option ML</p>	H1	10.00 / 254
	H2	10.75 / 273.1
	H3	11.5 / 292.1
	W1	8.00 / 203.2
	W2	6.00 / 152.4
	D	6.26 / 159.1
<p>— Polycarbonate enclosure with lugs Enclosure option PL</p>	H1	10.35 / 291.9
	H2	10.75 / 273.1
	H3	11.69 / 296.9
	W1	8.35 / 212.1
	W2	6.00 / 152.4
	D	6.79 / 172.5

**OVRH series**  
Dimensions

Dimensions OVRHT3D		Value	Inches / millimeters
<p>The image contains three technical drawings of the OVRHT3D surge protection device. The top-left drawing is a front view showing a square face with a width of 2.75 and a height of 2.75. The top-right drawing is a side view showing a total width of 4.25 and a height of 2.41, with a mounting bracket width of 3.45. The bottom drawing is a top view showing a circular terminal with a diameter of 1.38 and a mounting bracket width of 1.22.</p>	W	4.25/ 107.95	
	D	2.41/61.214	
	H	2.75/69.85	

## OVRHMSU series

Series-connected suppression filter system



### Product features

The OVRHMSU is engineered for hard-wired installation within or adjacent to electrical loads such as outdoor lighting, robotics, process automation systems, motors, HVAC systems, pumps, heaters, programmable logic controllers and other point-of-use applications. Compact and powerful, the OVRHMSU protects these and other individual components from damaging electrical transients, high-frequency noise and high-energy disturbances. OVRHMSU provides 50kA of surge protection for loads up to 24 amps.



Product # **M S U** - [ ] - [ ] - [ ] - [ ] - [ ] - [ ]

kA/mode	Voltage*	
50 kA = 050	208	120/240
	240	208Y/120
	380	380Y/220
	480	480Y/277

Configuration*	Load Current	Modes of Protection
1G 1 Phase, Grounded	24 Amp	3 or 6
2G 2 Phase, Grounded, Split Phase		

\*Consult factory for additional voltage configurations

Input Voltages	Phase	Load Current Ratings (A)	Line Frequency Range (Hz)
120V	1	24	50-60
120/240V	Split-Phase	24	50-60
220V	1	24	50-60
220/380V	2	24	50-60
277V	1	24	50-60
277/480V	2	24	50-60

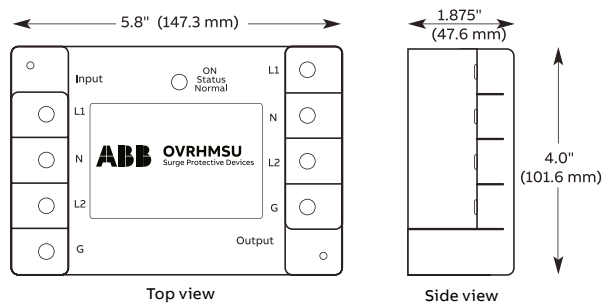

## OVRHMSU series

Series-connected suppression filter system

### High-frequency noise filtration

Model No.	Voltage	Mode	1KHz	10KHz	100KHz	1MHz	10MHz	100MHz
MSU50-120-1G-24A-3-ABB	120	L-N	6 dB	16 dB	42 dB	25 dB	21 dB	36 dB
MSU50-120/240-2G-24A-6-ABB	120/240	L-G	6 dB	6 dB	16 dB	55 dB	81 dB	80 dB
MSU50-220-1G-24A-3-ABB	220	L-N	6 dB	16 dB	42 dB	25 dB	21 dB	36 dB
MSU50-220/380-2G-24A-6-ABB	220/380	L-G	6 dB	6 dB	16 dB	55 dB	81 dB	80 dB
MSU50-277-1G-24A-3-ABB	277	L-N	6 dB	16 dB	42 dB	25 dB	21 dB	36 dB
MSU50-277/480-2G-24A-6-ABB	277/480	L-G	6 dB	6 dB	8 dB	36 dB	82 dB	81 dB

### OVRHMSU performance data

Model No.	System Voltage (VAC)	Current (A)	Phase 1 or 2	MCOV / UC (V)				VPR / VPL (Up)				I-n (kA)
				L-N	L-G	N-G	L-L	L-N	L-G	N-G	L-L	
MSU50-120-1G-24A-3-ABB	120	24A	1	150	300	150	N/A	800	800	800	N/A	20
MSU50-120/240-2G-24A-6-ABB	120/240	24A	2	150	300	150	300	800	N/A	800	1200	20
MSU50-220-1G-24A-3-ABB	220	24A	1	320	552	320	N/A	1200	1200	1000	N/A	20
MSU50-220/380-2G-24A-6-ABB	220/380	24A	2	320	552	320	552	1200	N/A	1000	2000	20
MSU50-277-1G-24A-3-ABB	277	24A	1	320	552	320	N/A	1200	1200	1000	N/A	20
MSU50-277/480-2G-24A-6-ABB	277/480	24A	2	320	552	320	552	1200	N/A	1000	2000	20

### Product Specifications

General Specifications	
Maximum Surge Current Rating	50kA Per Mode
Voltage (Single-Phase Applications)	120, 220 or 277
Voltage (3-Wire + Ground Applications)	220/380 or 277/480
Voltage (Split-Phase Applications)	120/240
Safety Listings	Listed by ETL to UL 1449 4th Edition, Type 4 for Type 2 SPD applications, cUL, and UL 1283 / Compliant to IEEE C62.41.1-2002, C62.41.2-2002 and C62.420-2002 / NFPA 70 [NEC], Article 285 / RoHS Compliant / CE, IEC 61643-11-2011 / EMC Directive 2004/108/EC
Product Design	Individually fused MOVs UL 1283 EMI/RFI filter
Ampacity Rating	24A
Dimensions	5.8"W x 4"H x 1.875"D
Weight	2.25 lbs.
Enclosure Type	Nonmetallic
Operating Environment	-40°F to 140°F (-40°C to 60°C) 5% – 95% Non-Condensing Humidity
Connection Method	Series/in-line; Terminal Block Termination
Connection Means	#8 Screws
Protection Modes	3 or 6
Warranty	5 Years

## Protection and safety

### OVRT2 series – Selection guide

#### Complete facility protection

Installing surge protection at the main distribution panel is only the beginning of protecting the entire operation. As most transient surges are created internally, it is necessary to install surge protection at sub-distribution panels (equipment protection) to be fully protected. Stepping down the  $I_{max}$  level from the service entrance panel toward equipment to be protected is recommended.

For example, if a 40 kA  $I_{max}$  SPD is installed in the main distribution panel, then 15 kA  $I_{max}$  SPDs should be installed in sub-distribution panels for equipment protection.

#### Coordination

It may be necessary to add a second surge protector, wired to the incoming unit, to achieve the required voltage protection and/or surge capacity. For Type 2 or 4 SPDs, installing this second unit a minimum of 1 m from the first unit will allow the two to work together, achieving the required protection.

#### Wiring rules

The impedance of the cables increases the voltage across the connected equipment. Therefore, the length of the cable between the surge protector and the equipment should be minimized.

The surge protective device should be installed as close to the equipment to be protected as possible. If this is not possible (the equipment is over 30 m from the panel), then a second surge protector must be installed.

#### Choosing the correct model

##### 1) Determine the service voltage

Consult qualified personnel if the facility or operation service voltage is unknown.

##### 2) Select the SPD maximum continuous operating voltage (MCOV, $U_c$ )

The MCOV should correspond to the service voltage. Example: If the service voltage is 480 V Delta, an SPD with 550 V or 660 V MCOV will be required. Surge protection devices must also provide a level of protection compatible with the withstand voltage of the equipment. This withstand voltage depends on the type of equipment and its sensitivity. The incoming surge protector may not provide adequate protection by itself, as certain electrical phenomena may greatly increase its residual voltage if cable lengths exceed 10 m. A second SPD may be necessary.

##### 3) Select the SPD surge capacity ( $I_{max}$ )

Surge capacity is the amount of energy the SPD can withstand from a single surge event. The higher the surge capacity, the longer the device will protect the system. A second surge protector may be required if the surge capacity of the first is not capable of diverting all surge current to ground. See coordination below.

##### 4) Remote monitoring (optional)

Integrated auxiliary contact for remote monitoring available on models with "TS" designation.

Consult "Selection tables" on next page for help in the selection of SPDs.

#### OVR DIN rail SPD – Product type description

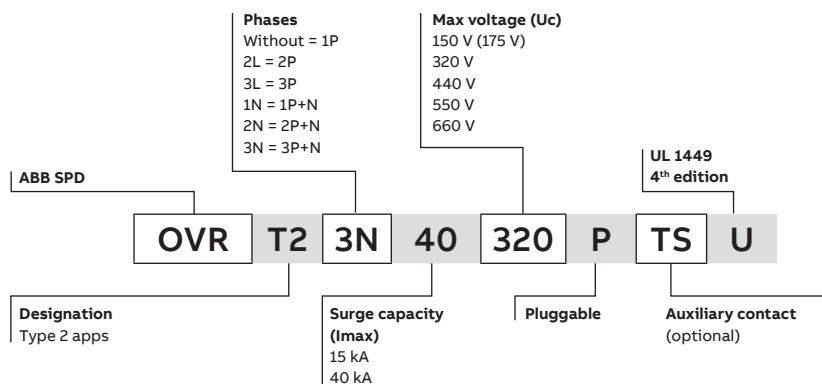



## OVRT2 series

### OVRT2 single-pole



#### Product features

- Type 4 SPD, UL 1449 4th Edition for Type 2 applications
- Metal oxide varistor (MOV) technology
- Single-pole design
- Replaceable and pluggable cartridges
- DIN rail-mounted SPD
- State indication flag standard on all units
- End-of-life signal standard on 40 kA units



Network type	Voltage	MCOV	VPR	Max. disch.	Nominal disch.	Part number	Repl. cartridge
Pole to be connected between L-N, L-G or L-L	120 V AC	150 V AC	0.6 kV	15 kA	5 kA	OVRT215150PU	OVRT215150CU
				40 kA	20 kA	OVRT240150PU	OVRT240150CU
	240...277 V AC	320 V AC	1.0 kV	15 kA	5 kA	OVRT215320PU	OVRT215320CU
				40 kA	20 kA	OVRT240320PTSU	OVRT240320CU
				40 kA	20 kA	OVRT240440PTSU	OVRT240440CU
				40 kA	20 kA	OVRT240550PTSU	OVRT240550CU
600 V AC	660 V AC	1.9 kV	40 kA	20 kA	OVRT240660PTSU	OVRT240660CU	
Neutral pole to be connected between N-G	230 V AC	255 V AC	1.2 kV	70 kA	20 kA	OVRT270NPU	OVRT270NCU

Electrical characteristics	
Operating frequency	(AC) 47–63 Hz
Modes of protection	L-N, L-G, N-G or L-L
Fault rating (SCCR)	200 kAIC – Upstream protection required (breaker / fuse)
Response time	< 25 nanoseconds
Standard monitoring	Cartridge state indicator flag
Mechanical characteristics	
Weight	0.25 lbs. (120 g)
Housing material	Thermoplastic, gray RAL 7035 / V0
Installation location	Type 1, indoor
Mounting method	DIN rail
Operating temperature	-40 °to 80 °C (-40 °to 175 °F)
Wire range (stranded / solid)	#6–14 AWG / #4–14 AWG
Product design	MOV technology

# OVRT2 series

## OVRT2 1N



### Product features

- Type 4 SPD, UL 1449 4th Edition for Type 2 applications
- Metal oxide varistor (MOV) technology
- 1p+N+Gnd complete design
- Replaceable and pluggable cartridges
- DIN rail-mounted SPD
- State indication flag standard on all units
- End-of-life signal standard on 40 kA units



Network type	Voltage	MCOV	VPR	Max. disch.	Nominal disch.	Part number	Repl. cartridge
Single-phase 2w+Gnd 	120 V AC	175 V AC	1.2 kV	15 kA	5 kA	OVRT21N15150PU	OVRT215150CU
				40 kA	20 kA	OVRT21N40150PU	OVRT240150CU
						OVRT21N40150PTSU	OVRT240150CU
	240–277 V AC	320 V AC	1.2 kV	15 kA	5 kA	OVRT21N15320PU	OVRT215320CU
				40 kA	20 kA	OVRT21N40320PTSU	OVRT240320CU
						OVRT21N40440PTSU	OVRT240440CU
480 V AC	550 V AC	1.2 kV	40 kA	10 kA	OVRT21N40550PTSU	OVRT240550CU	
600 V AC	660 V AC	1.2 kV	40 kA	10 kA	OVRT21N40660PTSU	OVRT240660CU	
Neutral pole	230 V AC	255 V AC	1.2 kV	70 kA	20 kA	-	OVRT270NCU

Electrical characteristics	
Operating frequency	50–60 Hz
Modes of protection	L-N and N-G
Fault rating (SCCR)	200 kAIC – Upstream protection required (breaker / fuse)
Response time	< 25 nanoseconds
Standard monitoring	Cartridge state indicator flag
Mechanical characteristics	
Weight	0.53 lbs. (240 g)
Housing material	Thermoplastic, gray RAL 7035 / V0
Installation location	Type 1, indoor
Mounting method	DIN rail
Operating temperature	-40 °to 80 °C (-40 °to 175 °F)
Wire range (stranded / solid)	#6–14 AWG / #4–14 AWG
Product design	MOV technology

## OVRT2 series

### OVRT2 2L



#### Product features

- Type 4 SPD, UL 1449 4th Edition for Type 2 applications
- Metal oxide varistor (MOV) technology
- 2p+Gnd complete design
- Replaceable and pluggable cartridges
- DIN rail-mounted SPD
- State indication flag standard on all units
- End-of-life signal standard on 40 kA units



Network type	Voltage	MCOV	VPR	Max. disch.	Nominal disch.	Part number	Repl. Cartridge
Split phase 2w+Gnd 	120 V AC	175 V AC	0.6 kV	15 kA	5 kA	OVRT22L15150PU	OVRT215150CU
				40 kA	20 kA	OVRT2240150PTSU	OVRT240150CU
	277 V AC	320 V AC	1.0 kV	15 kA	5 kA	OVRT22L15320PU	OVRT215320CU
				40 kA	20 kA	OVRT22L40320PTSU	OVRT240320CU

#### Electrical characteristics

Operating frequency	50–60 Hz
Modes of protection	L-L and L-G
Fault rating (SCCR)	200 kAIC – Upstream protection required (breaker / fuse)
Response time	< 25 nanoseconds
Standard monitoring	Cartridge state indicator flag

#### Mechanical characteristics

Weight	0.53 lbs. (240 g)
Housing material	Thermoplastic, gray RAL 7035 / V0
Installation location	Type 1, indoor
Mounting method	DIN rail
Operating temperature	-40 ° to 80 °C (-40 ° to 175 °F)
Wire range (stranded / solid)	#6–14 AWG / #4–14 AWG
Product design	MOV technology

# OVRT2 series

## OVRT2 2N



### Product features

- Type 4 SPD, UL 1449 4th Edition for Type 2 applications
- Metal oxide varistor (MOV) technology
- 2p+N+Gnd complete design
- Replaceable and pluggable cartridges
- DIN rail-mounted SPD
- State indication flag standard on all units
- End-of-life signal standard on 40 kA units



Network type	Voltage	MCOV	VPR	Max. disch.	Nominal disch.	Part number	Repl. Cartridge
<p>Split phase 2w+N+Gnd</p>	120 V AC	175 V AC	0.7 kV	15 kA	5 kA	OVRT22N15150PU	OVRT215150CU
	277 V AC	320 V AC	0.6 kV	40 kA	20 kA	OVRT22N40150PTSU	OVRT240150CU
			0.7 kV	40 kA	20 kA	OVRT22N15320PU	OVRT215320CU
	480 V AC	550 V AC	1.1 kV	40 kA	20 kA	OVRT22N40320PTSU	OVRT240320CU
			1.4 kV	40 kA	10 kA	OVRT22N40440PTSU	OVRT240440CU
600 V AC	660 V AC	2.0 kV	40 kA	10 kA	OVRT22N40550PTSU	OVRT240550CU	
600 V AC	660 V AC	2.0 kV	40 kA	10 kA	OVRT22N40660PTSU	OVRT240660CU	
Neutral pole	230 V AC	255 V AC	1.2 kV	70 kA	20 kA	-	OVRT270NCU

Electrical characteristics	
Operating frequency	50–60 Hz
Modes of protection	L-L, L-N, N-G and L-G
Fault rating (SCCR)	200 kAIC – Upstream protection required (breaker / fuse)
Response time	< 25 nanoseconds
Standard monitoring	Cartridge state indicator flag
Mechanical characteristics	
Weight	0.80 lbs. (360 g)
Housing material	Thermoplastic, gray RAL 7035 / V0
Installation location	Type 1, indoor
Mounting method	DIN rail
Operating temperature	-40 °to 80 °C (-40 °to 175 °F)
Wire range (stranded / solid)	#6–14 AWG / #4–14 AWG
Product design	MOV technology

## OVRT2 series

### OVRT2 2L



#### Product features

- Type 4 SPD, UL 1449 4th Edition for Type 2 applications
- Metal oxide varistor (MOV) technology
- 3p+Gnd complete design
- Replaceable and pluggable cartridges
- DIN rail-mounted SPD
- State indication flag standard on all units
- End-of-life signal standard on 40 kA units



Network type	Voltage	MCOV	VPR	Max. disch.	Nominal disch.	Part number	Repl. Cartridge
	120 V AC	175 V AC	0.6 kV	15 kA	5 kA	OVRT23L15150PU	OVRT215150CU
				40 kA	20 kA	OVRT23L40150PTSU	OVRT240150CU
	277 V AC	320 V AC	1.0 kV	15 kA	5 kA	OVRT23L15320PU	OVRT215320CU
				40 kA	20 kA	OVRT23L40320PTSU	OVRT240320CU
	347 V AC	440 V AC	1.3 kV	40 kA	10 kA	OVRT23L40440PTSU	OVRT240320CU
	480 V AC	550 V AC	1.7 kV	40 kA	10 kA	OVRT23L40550PTSU	OVRT240550CU

#### Electrical characteristics

Operating frequency	50–60 Hz
Modes of protection	L-L and L-G
Fault rating (SCCR)	200 kAIC – Upstream protection required (breaker / fuse)
Response time	< 25 nanoseconds
Standard monitoring	Cartridge state indicator flag

#### Mechanical characteristics

Weight	0.80 lbs. (360 g)
Housing material	Thermoplastic, gray RAL 7035 / V0
Installation location	Type 1, indoor
Mounting method	DIN rail
Operating temperature	-40 °to 80 °C (-40 °to 175 °F)
Wire range (stranded / solid)	#6–14 AWG / #4–14 AWG
Product design	MOV technology

# OVRT2 series

## OVRT2 3N



### Product features

- Type 4 SPD, UL 1449 4th Edition for Type 2 applications
- Metal oxide varistor (MOV) technology
- 3p+N+Gnd complete design
- Replaceable and pluggable cartridges
- DIN rail-mounted SPD
- State indication flag standard on all units
- End-of-life signal standard on 40 kA units



Network type	Voltage	MCOV	VPR	Max. disch.	Nominal disch.	Part number	Repl. Cartridge
	120 V AC	175 V AC	0.6 kV	15 kA	5 kA	OVRT23NN15150PU	OVRT215150CU
			1.2 kV	40 kA	20 kA	OVRT23N40150PTSU	OVRT240150CU
	277 V AC	320 V AC	1.2 kV	15 kA	5 kA	OVRT23N15320PU	OVRT215320CU
				40 kA	20 kA	OVRT23N40320PTSU	OVRT240320CU
	347 V AC	440 V AC	1.2 kV	40 kA	10 kA	OVRT23N40440PTSU	OVRT240440CU
480 V AC	550 V AC	1.2 kV	40 kA	10 kA	OVRT23N40550PTSU	OVRT240550CU	
600 V AC	660 V AC	1.2 kV	40 kA	10 kA	OVRT23N40660PTSU	OVRT240660CU	
Neutral pole	230 V AC	255 V AC	1.2 kV	70 kA	20 kA	-	OVRT270NCU

Electrical characteristics	
Operating frequency	50–60 Hz
Modes of protection	L-L and L-G
Fault rating (SCCR)	200 kAIC – Upstream protection required (breaker / fuse)
Response time	< 25 nanoseconds
Standard monitoring	Cartridge state indicator flag
Mechanical characteristics	
Weight	1.05 lbs. (480 g)
Housing material	Thermoplastic, gray RAL 7035 / V0
Installation location	Type 1, indoor
Mounting method	DIN rail
Operating temperature	-40 °to 80 °C (-40 °to 175 °F)
Wire range (stranded / solid)	#6–14 AWG / #4–14 AWG
Product design	MOV technology

## OVRT2 series

### Dimensions

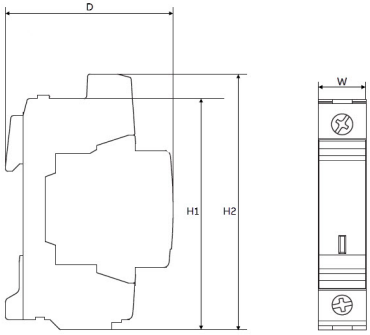
Dimensions OVRT2		Value	Inches / millimeters
		W	0.70 / 17.8
		D	2.55 / 64.8
		H1 (without TS option)	3.35 / 85.0
		H2 (with TS option)	3.88 / 98.5

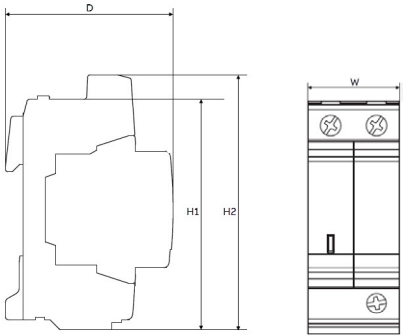
Dimensions OVRT2 1N, OVRT2 2L		Value	Inches / millimeters
		W	1.40 / 35.6
		D	2.55 / 64.8
		H1 (without TS option)	3.35 / 85.0
		H2 (with TS option)	3.88 / 98.5

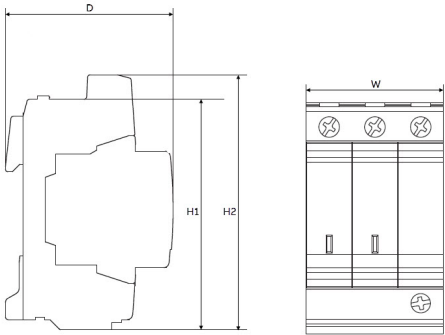
Dimensions OVRT2 2N, OVRT2 3L		Value	Inches / millimeters
		W	2.10 / 53.4
		D	2.55 / 64.8
		H1 (without TS option)	3.35 / 85.0
		H2 (with TS option)	3.88 / 98.5

**OVRT2 series**  
Dimensions

Dimensions OVRT2 3N		Value	Inches / millimeters
	W		2.80 / 71.2
	D		2.55 / 64.8
	H1 (without TS option)		3.35 / 85.0
	H2 (with TS option)		3.88 / 98.5

## OVR RS485Q and SL R485 series



The ABB range of data and signal surge protective devices are designed to protect sensitive equipment connected to data and telephone lines. These devices complement the OVR power SPD units for a complete and effective system protection solution against power and data surges.

### Application

OVR RS485Q and SL RS485 series UL 497B listed surge protective devices (SPDs) are specifically designed for RS485 and Fieldbus applications, such as Profibus DP. For installations at service entrances or within the building infrastructure to protect against lightning flashover (typically the service entrance location) and internal transient voltage activity.

Available as compact OVR RS485Q (4-pair) or Slim Line OVR SL RS485 (1-pair) versions for installations where a high number of lines require protection.



OVR SL RS485 and OVR RS485Q/PT have UL 497B approval under UL file QVGO:E240341

Technical specifications and standards		
<b>Key features</b>		
Protection mode	Normal and common	
Status indicator	LED status indication option	
Technology	Multi-stage hybrid	
Installation	DIN rail	
<b>Electrical specification</b>		
Nominal voltage <sup>1</sup>	OVR SL RS485 series	OVR RS485Q series
Maximum working voltage $U_c$ (RMS/DC) <sup>2</sup>	15 V	11 V / 16.7 V
Current rating (signal)	11 V / 16.7 V	300 mA
In-line resistance (per line $\pm 10\%$ )	300 mA	1 $\Omega$
Bandwidth (-3 dB, 50 $\Omega$ system)	1 $\Omega$	45 MHz
<b>Transient specification</b>		
<b>Let-through voltage (all conductors)<sup>3</sup> Up</b>		
C2 test 4 kV 1.2/50 $\mu$ s, 2 kA 8/20 $\mu$ s to EN/IEC 61643-21	55.0 V	
C1 test 1 kV, 1.2/50 $\mu$ s, 0.5 kA 8/20 $\mu$ s to EN/IEC 61643-21	42.0 V	
B2 test 4 kV 10/700 $\mu$ s to EN/IEC 61643-21	27.2 V	
5 kV, 10/700 $\mu$ s <sup>4</sup>	28.2 V	

<sup>1</sup>Nominal voltage (RMS/DC or AC peak) measured at  $< 10 \mu$ A

<sup>2</sup>Maximum working voltage (RMS/DC or AC peak) measured at  $< 5$  mA

<sup>3</sup>The maximum transient voltage let-through of the protector throughout the test ( $\pm 10\%$ ), line to line and line to ground, both polarities. Response time  $< 10$  ns

<sup>4</sup>Test to IEC 61000-4-5:2006; ITU-T (formerly CCITT) K.20, K.21 and K.45; Telcordia GR-1089- CORE, Issue 2:2002, ANSI TIA/EIA/IS-968-A:2002 (formerly FCC Part 68)

## OVR RS485Q and SL RS485 series

Maximum discharge surge current (I <sub>max</sub> )		OVR SL RS485 series	OVR RS485Q series
D1 test 10/350 μs to BS EN/EN/IEC 61643-21:	- Per signal wire 2.5 kA - Per pair	1.25 kA 2.5 kA	2.5 kA 5 kA
8/20 μs to ITU-T K.45:2003, IEEE C62.41.2:2002:	- Per signal wire - Per pair	10 kA 20 kA	

Mechanical specification		OVR SL RS485 series	OVR RS485Q series
Temperature range		-40 to +80 °C	
Connection type		Screw terminal — max. torque 0.8 N	Pluggable 12-way screw terminal/PT version: Pluggable 12-way screwless push terminal
Max. Conductor size (stranded)		12 AWG/ 4 mm <sup>2</sup>	14 AWG/ 2.5 mm <sup>2</sup>
Ground connection		Via DIN rail or 4 mm <sup>2</sup> ground terminal — max. torque 0.8 Nm	Via DIN rail or M5 threaded hole in base of unit
Case material		FR Polymer UL 94 V-0	
Weight	- Unit	0.08 kg/ 0.18 lb	0.1 kg/ 0.22 lb
Dimensions		See diagram below	

Available configurations			
Catalog number	Global ID	# Pairs	Description
OVRSLRS485UL	7TCA085400R0551	1	Slim Line, RS485, 1 pair + shield/screen
OVRSLRS485LUL	7TCA085400R0552	1	Slim Line, RS485, 1 pair + shield/screen, with LED status indication
OVRSLRS485LMUL	7TCA085400R0600	1	Replacement module for Slim Line, RS485, 1 pair + shield/screen, with LED status indication
OVRRS485QUL	7TCA085400R0572	4	Pluggable screw terminals, RS485, 4 pair + shield/screen for each pair
OVRRS485QPTUL	7TCA085400R0579	4	Pluggable push-in terminals, RS485, 4 pair + shield/screen for each pair

## OVR Q series



The ABB OVR Q series of data and signal surge protective devices are designed to protect sensitive equipment connected to data and telephone lines. These devices complement the OVR power SPD units for a complete and effective system protection solution against surges on data and power lines.

### Application

OVR Q series UL 497B listed surge protective devices (SPDs) are specifically designed for where installation space is at a premium and large numbers of lines require protection. For installations, connect in series with the signal or data line either near where it enters or leaves the building or close to the equipment being protected. Install in a cabinet/cubicle close to the system's ground star to protect against lightning flashover (typically the service entrance location) and internal transient voltage activity.



OVR Q series has UL 497B approval under UL file QVGO:E240341

### Technical specifications and standards

#### Key features

Protection mode	Normal and common
Status indicator	No
Technology	Multi-stage hybrid
Installation	DIN rail

Electrical specification	OVR Q series
Nominal voltage <sup>1</sup>	30 V
Maximum working voltage $U_c$ (RMS/DC) <sup>2</sup>	26 V/ 37.8 V
Current rating (signal)	-
In-line resistance (per line $\pm 10\%$ )	-
Bandwidth (-3 dB, 50 $\Omega$ system)	-

#### Transient specification

##### Let-through voltage (all conductors)<sup>3</sup> Up

C2 test 4 kV 1.2/50 $\mu$ s, 2 kA 8/20 $\mu$ s to EN/IEC 61643-21	53.0 V
C1 test 1 kV, 1.2/50 $\mu$ s, 0.5 kA 8/20 $\mu$ s to EN/IEC 61643-21	48.0 V
B2 test 4 kV 10/700 $\mu$ s to EN/IEC 61643-21	43.5 V
5 kV, 10/700 $\mu$ s <sup>4</sup>	44.3 V

<sup>1</sup>Nominal voltage (RMS/DC or AC peak) measured at  $< 5 \mu$ A

<sup>2</sup>Maximum working voltage (RMS/DC or AC peak) measured at  $< 5$  mA leakage (OVR 30Q)

<sup>3</sup>The maximum transient voltage let-through of the protector throughout the test ( $\pm 10\%$ ), line to line and line to ground, both polarities. Response time  $< 10$  ns

<sup>4</sup>Test to IEC 61000-4-5:2006, ITU-T (formerly CCITT) K.20, K.21 and K.45, Telcordia GR-1089-CORE, Issue 2:2002, ANSI TIA/EIA/IS-968-A:2002 formerly FCC Part 68)

## OVR Q series

Maximum discharge surge current (I <sub>max</sub> )		OVR Q series
D1 test 10/350 μs to	- Per signal wire	2.5 kA
BS EN/EN/IEC 61643-21	- Per pair	5 kA
8/20 μs to ITU-T K.45:2003,	- Per signal wire	10 kA
IEEE C62.41.2:2002:	- Per pair	20 kA

Mechanical specification	OVR Q series
Temperature range	-40 to +80 °C
Installation location	Connect in series with the signal or data line either near where it enters or leaves the building or close to the equipment being protected. Install in a cabinet/ cubicle close to the system's ground star point.
Connection type	Pluggable 12-way screw terminal - maximum torque 0.6 Nm/ PT version: Pluggable 12-way screwless push terminal
Conductor size (stranded)	2.5 mm <sup>2</sup>
Ground connection	Via DIN rail or M5 threaded hole in base of unit
Case material	FR polymer UL 94 V-0
Weight:	
- Unit	0.1 kg
- Packaged (each)	0.12 kg
Dimensions	See diagram below

Available configurations			
Catalog number	Voltage	Description	Global ID
OVR30QUL	30 V	With screw terminals	7TCA085400R0568
OVR30QPTUL	30 V	With screwless push terminals	7TCA085400R0575

## OVR SL series



The ABB OVR SL series of data and signal surge protective devices are designed to protect sensitive equipment connected to data and telephone lines. These devices complement the OVR power SPD units for a complete and effective system protection solution against surges for data and power lines.

### Application

OVR SL series UL 497B listed surge protective devices (SPDs) are specifically designed for applications where installation space is at a premium and a large number of lines require protection (e.g., process control, high-speed digital communication equipment or systems with long signal lines).

Connect in series with the data communication or signal line either near or where it enters or leaves the building or close to the equipment being protected (e.g., within its control panel.) It must be close to the system's ground star point. Install the SPD within an existing cabinet/cubicle or in a separate enclosure.



OVR SL series have UL 497B approval under UL file QVGO:E240341

### Technical specifications and standards

#### Key features

Protection mode	Normal and common
Technology	Multi-stage hybrid
Installation	DIN rail

Electrical specification	OVR SL06 series	OVR SL30 series	OVR SL180 series
Nominal voltage <sup>1</sup>	6 V	30 V	180 V
Maximum working voltage U <sub>c</sub> (DC) <sup>2</sup>	7.79 V	36.7 V	190 V
Maximum working voltage U <sub>c</sub> (AC RMS)	5 V	25 V	130 V
Current rating (signal)	750 mA	-	250 mA
In-line resistance (per line ±10%)	1 Ω	-	6.8 Ω
Bandwidth (-3 dB 50 Ω system)	45 MHz	-	-

<sup>1</sup>Nominal voltage (RMS/DC or AC peak) measured at < 5 μA

<sup>2</sup>Maximum working voltage (RMS/DC or AC peak) measured at < 5 mA leakage

## OVR SL series

Transient specification	OVR SL06 series	OVR SL30 series	OVR SL180 series	
<b>Let-through voltage (all conductors)<sup>3</sup> Up</b>				
C2 test 4 kV 1.2/50 $\mu$ s, 2 kA 8/20 $\mu$ s to BS EN/EN/IEC 61643-21	36.0 V	63.0 V	215 V	
C1 test 1 kV, 1.2/50 $\mu$ s, 0.5 kA 8/20 $\mu$ s to BS EN/EN/IEC 61643-21	26.2 V	51.3 V	205 V	
B2 test 4 kV 10/700 $\mu$ s to BS EN/EN/ IEC 61643-21	16.0 V	45.4 V	203 V	
5 kV, 10/700 $\mu$ s <sup>4</sup>	17.0 V	46.3 V	200 V	
<b>Maximum surge current</b>				
D1 test 10/350 $\mu$ s to EN/EN/IEC 61643-21	- per signal wire BS	1.25 kA	-	-
	- per pair	2.5 kA	-	-
8/20 $\mu$ s to ITU-T K.45:2003 IEEE C62.41.2:2002	- per signal wire	10 kA	-	-
	- per pair	20 kA	-	-

<sup>3</sup>The maximum transient voltage let-through of the protector throughout the test ( $\pm 10\%$ ), line to line and line to ground, both polarities Response time < 10 ns

<sup>4</sup>Test to IEC 61000-4-5:2006, ITU-T (formerly CCITT) K.20, K.21 and K.45, Telcordia GR-1089-CORE, Issue 2:2002, ANSI TIA/EIA/IS-968-A:2002 (formerly FCC Part 68)

<b>Mechanical specification</b>		
Temperature range		-40 to +80 °C
Installation location		Connect in series with the data communication or signal line either near where it enters or leaves the building or close to the equipment being protected (e.g., within its control panel). Either way, it must be very close to the system's ground star point. Install SPDs either within an existing cabinet/cubicle or in a separate enclosure.
Connection type		Screw terminal - maximum torque 0.8 Nm
Conductor size (stranded)		4 mm <sup>2</sup>
Ground connection		Via DIN rail or 4 mm <sup>2</sup> ground terminal — max. torque 0.8 Nm
Case material		FR polymer UL 94 V-0
Weight	- unit	0.08 kg
Dimensions		See diagram below

<b>Available configurations</b>		
Catalog number	Description	Global ID
OVRSL06UL	6 V slim data SPD for 2-wire signal	7TCA085400R0527
OVRSL06IUL	6 V slim data SPD for 2-wire signal and isolated shield	7TCA085400R0528
OVRSL30UL	30 V slim data SPD for 2-wire signal	7TCA085400R0535
OVRSL30IUL	30 V slim data SPD for 2-wire signal and isolated shield	7TCA085400R0536
OVRSL180UL	180 V slim data SPD for 2-wire signal	7TCA085400R0547

**OVR SL RS485 and OVR RS485Q series**  
 Dimensions

Dimensions OVR SL RS485	
Value	Inches / millimeters
W	4.19 / 106.5
D	0.28 / 7
H	4.12 / 104.6

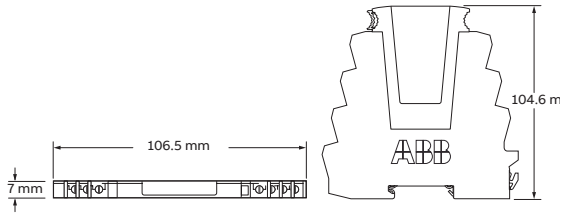

Dimensions OVR RS485Q	
Value	Inches / millimeters
W	3.74 / 95
D	0.71 / 18
H	3.42 / 87

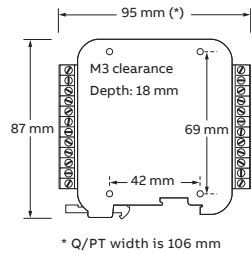

## OVR Q and OVR SL series

### Dimensions

#### Dimensions OVR Q series

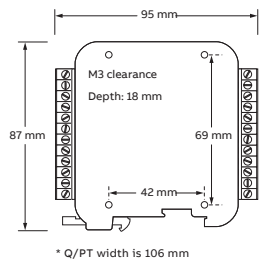

Value	Inches / millimeters
W	3.74 / 95
D	0.71 / 18
H	3.42 / 87

#### Dimensions OVR SL

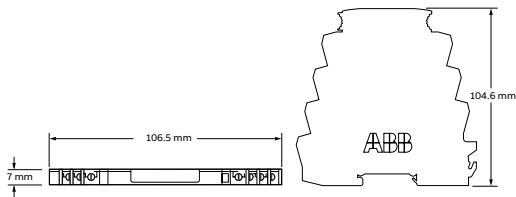

Value	Inches / millimeters
W	4.19 / 106.5
D	0.28 / 7
H	4.12 / 104.6

## DIN-rail SPDs for distribution panels

UL 1449 4th edition

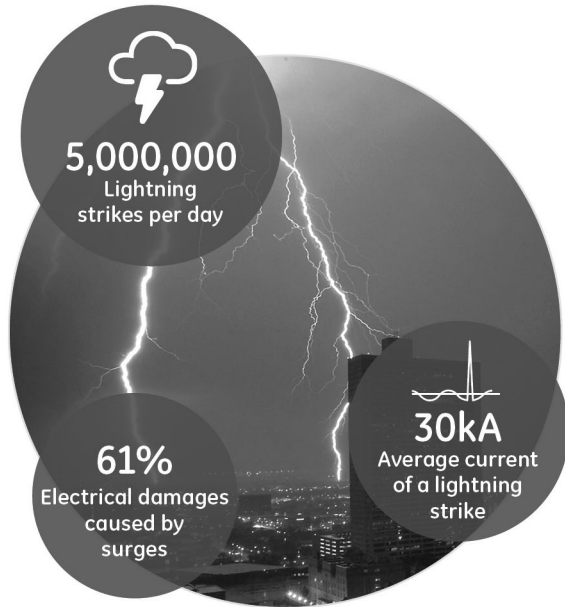

### Risk of Electrical Surges

Lightning and surge protection electrical and electronic equipment is indispensable in the daily activities of today's businesses and individuals.

Such devices are connected to the electricity grid, often exchanging data and signals through communication lines and are usually sensitive to disturbances.

These interconnecting networks provide a propagation path for overvoltages.

Protection against lightning and overvoltages not only ensures the safety of people, goods and equipment, but also ensures continuity of installation services and meets criteria of energy efficiency.

Overvoltage protection extends the life of the equipment by more than 20%, which significantly reduces the volume of electronic waste. It also reduces the power consumption of the installations, all of which translates into cost savings and environmental sustainability.

### Transient Voltage Surges in LV Power Lines

Transient overvoltages are voltage surges that can reach tens of kilovolts with a duration in the order of microseconds.

Despite their short duration, the high energy content can cause serious problems to equipment connected to the line, from premature aging to destruction, causing disruptions to service and financial loss.

This type of surge can have various different causes, including atmospheric lightning directly striking the external protection (lightning rods) on a building or transmission line, or the associated induction of electromagnetic fields on metallic conductors. Outdoor and longer lines are the most exposed to these fields, which often receive high levels of induction.

It is also common for non-weather phenomena such as transformer center switching or the disconnection of motors or other inductive loads to cause voltage spikes in adjacent lines.

The protector will discharge excess energy to earth, thus limiting the peak voltage to a value acceptable for the electrical equipment connected.

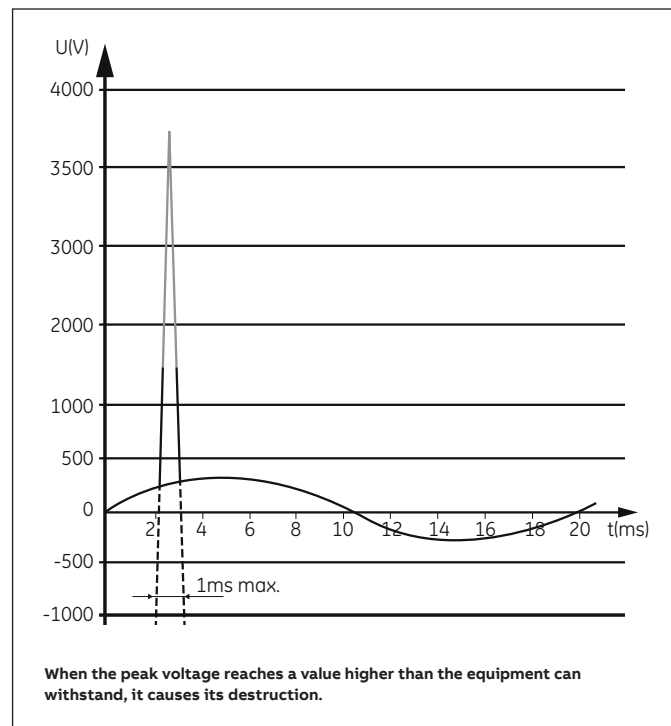

## DIN-rail SPDs for distribution panels

UL 1449 4th edition

Terminology of SPD electrical characteristics

$I_{max}$

**Maximum Discharge Capacity**

Maximum peak current, per phase, in 8/20  $\mu$ s wave that the protection device is able to withstand.

VPR

**Voltage Protection Rating**

This indicates the maximum residual voltage between the terminals of the protection device during application of an  $I_n$  peak current.

$I_n$

**Nominal Discharge Current Rating**

Peak current in 8/20  $\mu$ s wave that the protection device can withstand on 15 occasions without reaching the end of its service life.

MCOV

**Maximum Continuous Operating Voltage**

This indicates the maximum effective or direct current voltage that can be permanently applied to the terminals of the protection device.

TYPE

**Type 1**

Permanently connected SPDs intended for installation between the secondary of the service transformer and the line side of the service equipment (main panel) overcurrent device, as well as the load side, including watt-hour meter socket enclosures and intended to be installed without an external overcurrent protective device.

**Type 2**

Permanently connected SPDs intended for installation on the load side of the service equipment (main panel) overcurrent device; including SPDs located at the branch panel.

**Type 3**

Point of utilization SPDs, installed at a minimum conductor length of 30 feet (10 meters) from the electrical service panel to the point of utilization. For example cord connected, direct plug-in, receptacle type and SPDs installed at the utilization equipment being protected. The distance 30 feet (10 meters) is exclusive of conductors provided with or used to attach SPDs that the protection device is able to withstand.

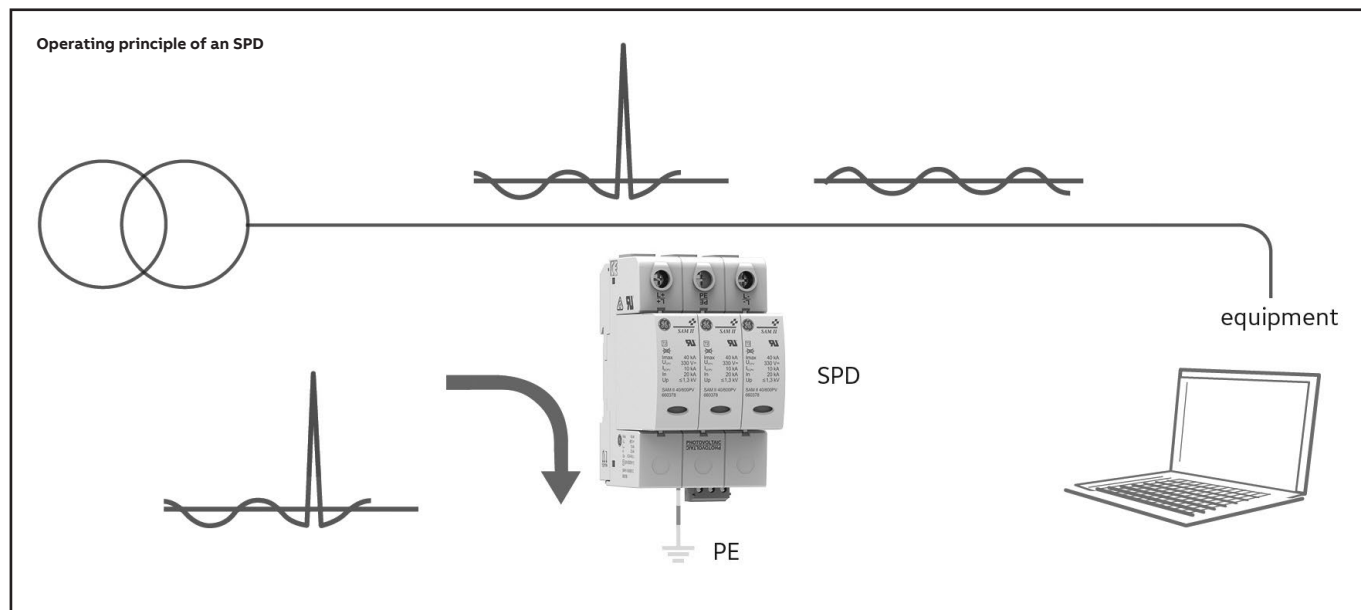

## DIN-rail SPDs for distribution panels

UL 1449 4th edition  
Standards

The Underwriters Laboratories (UL) standard for surge protective devices (SPDs) has been the primary safety standard for surge protection since the first edition was published in 1985, the fourth edition became mandatory for AC SPDs in March 2016.

The objective of UL 1449 has always been to increase safety in terms of surge protection.

### Change in the standard's name: From TVSS to SPDs

Prior to UL 1449 4th Edition taking effect, the devices this standard covers were known as Transient Voltage Surge Suppressors (TVSS), operating on power circuits not exceeding 600 V. With the inception of the 3<sup>rd</sup> and 4<sup>th</sup> Edition, these devices are now known as Surge Protective Devices (SPDs), and may operate on power circuits not exceeding 1500 V DC.

This new designation moves the UL standard closer to the international designation and to IEC standards.

### The different type designations of surge protective devices

The UL 1449 placed SPDs into five different Type categories based on installation location within an electrical system. While Type 1, Type 2 and Type 3 categories refer to different types of SPDs that can be installed at specific locations, Type 4 and Type 5 categories refer to components used in an SPDs configuration.

**Type 1** - "Permanently connected SPDs intended for installation between the secondary of the service transformer and the line side of the service equipment overcurrent device."

**Type 2** - "Permanently connected SPDs intended for installation on the load side of the service equipment overcurrent device."

**Type 3** - "Point of utilization SPDs, installed at a minimum conductor length of 10 meters (30 feet) from the electrical service panel."

**Type 4** - Component assemblies - "Component assembly consisting of one or more Type 5 components together with a disconnect (integral or external) or a means of complying with the limited current tests."

**Type 1, 2, 3** - Component assemblies - "Consists of a Type 4 component assembly with internal or external short circuit protection."

**Type 5** - "Discrete component surge suppressors, such as MOVs that may be mounted on a PWB, connected by its leads or provided within an enclosure with mounting means and wiring terminations."

The closer an SPD is installed to the equipment, the better the protection is. This is a push in the direction of providing stepped protection including external and internal surge protection.

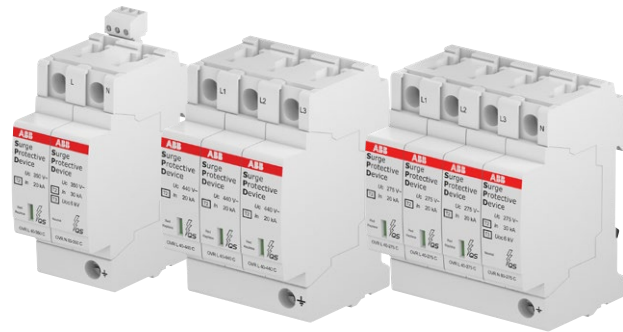

### The measured voltage protection level

The Measured Limiting Voltage (MLV) is the maximum magnitude of voltage measured at the application of a specific impulse wave shape.

When applying a certain surge current on the SPD the measured voltage at the device terminals is the so called "let-through voltage."

In UL 1449 2nd Edition, the let-through voltage was referred to as Suppressed Voltage Rating (SVR) and was calculated with a 0.5 kA surge wave form at 6 kV. The new designation is Voltage Protection Rating (VPR) and is calculated with a 3 kA surge wave form at 6 kV.

All products you will find in this chapter have been certified according to the UL 1449 4th Edition.

The MLV will allow comparison of different types of SPDs with regards to the let-through voltage. However, it is important to note that the surge current used to measure the let-through voltage is six times higher in the 3<sup>rd</sup> and 4<sup>th</sup> Edition than in the 2<sup>nd</sup> Edition. This means that, comparing the obsolete SVR designation with the new VPR ratings will not be valid, as VPR ratings will of course be higher than SVR ratings.

## DIN-rail SPDs for distribution panels

UL 1449 4th edition  
Standards

### Wiring Diagrams According to ANSI C84.1

The majority of modern installations in both the US and Canada feature the following kind of power distribution system.



Single Phase System		Residential Buildings
<p><b>Single Phase 2 Wires</b> 120/240/277V</p>	<p><b>Split Phase 3 Wires</b> 240/120V, 480/240V</p>	<p>i.e. Single phase 240 (Ph-Ph)/120V (to GRND) Grounded midpoint</p> <p>For example: 120V are used on the wall receptacle and 240V for ovens, ranges, air conditioning and laundry dryers</p>
Three Phase/Three Wire System		Industrial and Commercial Buildings
<p><b>Delta 240/480/600V</b></p>		
Three Phase/Four Wire System		Industrial and Commercial Buildings
<p><b>Grounded Wye</b> 208Y/120V, 480Y/277V, 600Y/347V</p>	<p><b>High-Leg Delta</b> 240/120V HLD</p>	<p>* Y describes the solidly grounded circuit. The value "Y" indicates the voltage between phases. The value behind the slash indicates the voltage between phase and the grounding or neutral conductor.</p>

## Protection block assembly

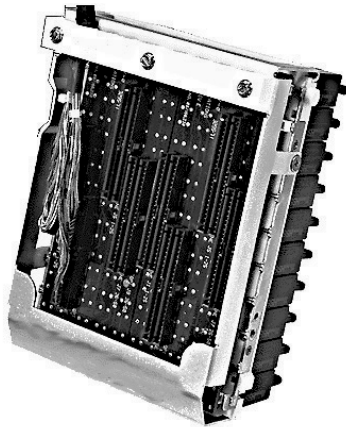

Protection Block Assembly

### Introduction

The ABB 427 patented 5 Pin Protection Block Assembly is equipped with a multi-layered printed circuit board, providing a connectorized interface for cable assemblies. It accommodates 25, 50 or 100 pair cable. It is used in many applications, including: central offices, remote switching sites, customer premises and building entrances, to protect telephone and voice/data lines.

When wiring cabinets with conventional wire wrap blocks each block becomes a different part number and causes difficulty for OEMs who have to inventory parts.

The same ABB 427 Protection Block Assembly is used in every position of a cabinet or mainframe. The cables are now treated as less expensive parts and are stocked by length and mating connector type. Manual labor, in running cables and making wire wrap connections, is reduced significantly by employing ABB Connectorized Block Assemblies.

### Protection Block Assembly - Surge Protection Device

Pair	Block Type	Hood	Product Number
50	Marconi Block	YES	427-050-202
100	Avaya Block	YES	427-100-102
100	Marconi Block	YES	427-100-202
100	Corning Block	YES	427-100-302

### Specifications

Voltage Class:	600V
BIL rating:	10kV
Primary Currents:	10 to 5000 amps

### Performance Features

- Gold pins and sockets ensure proper electrical connections
- Self-locking aluminum hood (optional) provides protection to connectors and printed circuit board and serves as the cable strain relief tie point
- Multi-layered printed circuit board
- Handle heavy transient current surges
- U.S. Patent No. 5,457,593

### Benefits

- Provides maximum reliability by eliminating all wire wraps
- Provides the high quality installation of a protection block
- Provides additional flexibility for equipment installations
- Easily serviceable in the field
- Eliminates the need for wire wrapping
- Allows connectorization into many different applications and greatly reduces installation, labor and repair costs
- All cables connected to this unit can be removed, permitting specific cable change out or change out of the entire protection block assembly. This allows the protected equipment to quickly be put back into service.
- Covered by a two year limited product warranty