

NOTES:

1 THIS CABLE COMES INSTALLED WITH 2100616-001. ONE END IS CONNECTED TO BUSBAR. LOOSE END WITH RING LUG MUST BE CONNECTED TO BATTERY (-) BLK DURING BATTERY KIT INSTALLATION.

2 MUST BE CONNECTED IN FIELD DURING BATTERY KIT INSTALLATION.

REVISIONS					
REV	ACTION	DRAWN	CHECKED	APPROVED	DATE
AB	D13035	KASTNER	KASTNER	HOLLAND	02/03/01
AC	D14060	KASTNER	KASTNER	BUSHNELL	03/01/08
AD	D20587	ROBERTSON	ROBERTSON	BUSHNELL	07/06/05

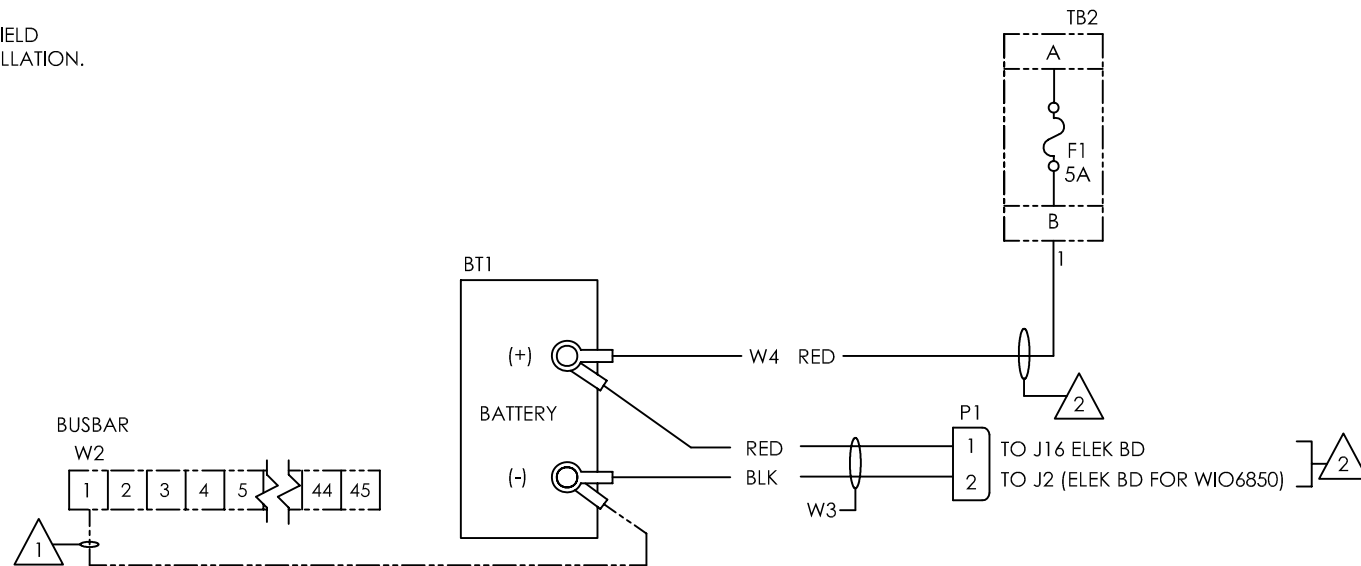

-001, -003 & -005 CONFIGURATION

ASSEMBLY/QUANTITY		001	ITEM NO.	PART NUMBER	DESCRIPTION	REF/ZONE DESIG MATERIAL	UNIT MEAS
DO NOT SCALE DRAWING		UNLESS OTHERWISE SPECIFIED DIMENSIONS ARE IN INCHES		PRODUCT LINE	LEVEL	TOTALFLOW®	
THIRD ANGLE PROJECTION		TOLERANCES ARE:		DESIGN	DATE	TOTALFLOW Products	
		DECIMAL		J. BUSHNELL	01/12/13	TITLE	
		ANGULAR		A. KASTNER	02/02/28	WIRING INTERCONNECT	
		.XX ± --		A. KASTNER	02/02/28	BATTERY KIT, XRC6890/WIO6850	
		.XXX ± --		A. KASTNER	02/02/28	BATTERY OPTION	
BREAK ALL SHARP CORNERS AND EDGES DIMENSIONS APPLY BEFORE FINISH		APPROVED	G. HOLLAND	02/03/01	SCALE	SIZE	DOC TYPE
					NONE	B	WI
					DRAWING NO.	REV	SHEET
					2100729	AD	1 OF 2

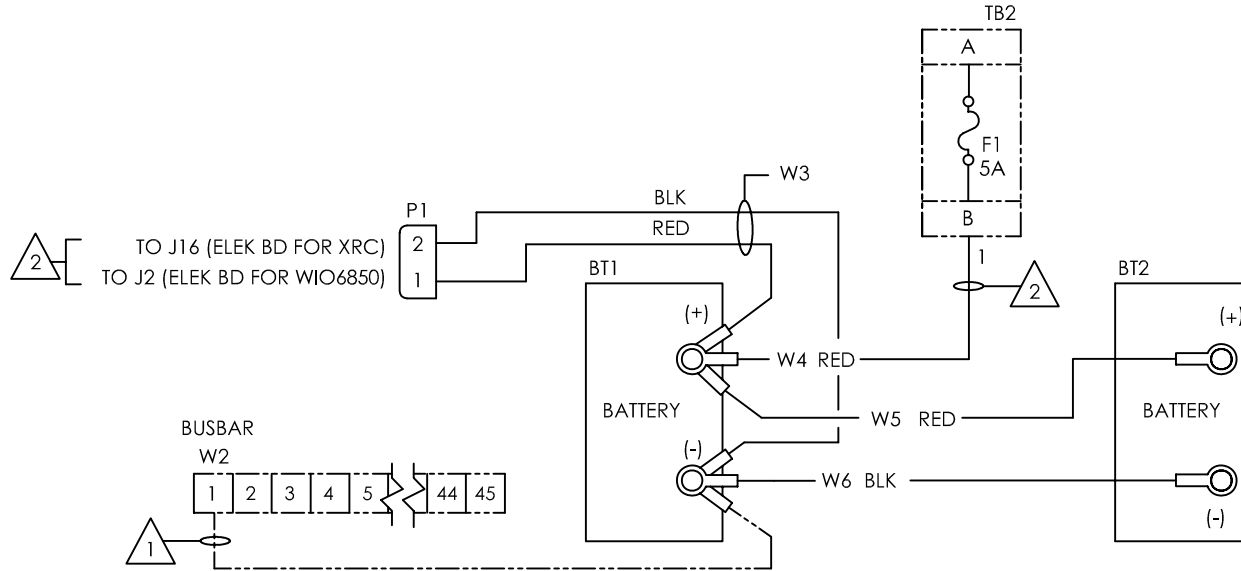

-002, -004 & -006 CONFIGURATION

SCALE	SIZE	DOC TYPE	DRAWING NO.	REV	SHEET
NONE	B	WI	2100729	AD	2 OF