









Preliminary - 1SDC200005D0201



# Emax

## Overview

	<b>Main characteristics</b>	<b>1</b>
	<b>Installations</b>	<b>2</b>
	<b>Overcurrent trip units and related accessories</b>	<b>3</b>
	<b>Accessories</b>	<b>4</b>
	<b>Overall dimensions</b>	<b>5</b>
	<b>Circuit diagrams</b>	<b>6</b>

**New Emax.**

**The evolution continues.**





The new Emax power circuit breakers are the result of ABB's constant commitment to look for new solutions, and of the know-how it has developed over the years. This is an incredibly innovative high quality circuit breakers range, designed to satisfy all application requirements. The innovation of the new Emax is really outstanding from all points of view: completely re-engineered trip units fitted with latest generation electronics, improved performances with the same dimensions and new applications to fulfil the latest market needs. The new electronics open a window on a world of extraordinary solutions, with connectivity options never seen before in the market. Discover the great advantages of ABB's new Emax. The evolution has been going on since 1942.

**New Emax.  
Lively performances.**





Continuing the tradition of ABB, the new Emax range offers performances at the top of its category. The Emax range offers you a great advantage: with the increased performances, you can use the smaller circuit breaker frames, obtaining considerable savings both in economic terms and in physical space within the switchgear. Emax E3L and E4L now reach top in terms of rated short circuit current (with 200kA as at 480V) whilst the Emax E2 is enhanced by the version L - with high performances in very compact dimensions. Always aware of the rapid changes in the market, ABB has also made some specific versions to cover new applications and simplify retrofitting operations.



# New Emax. Brilliant intelligence.



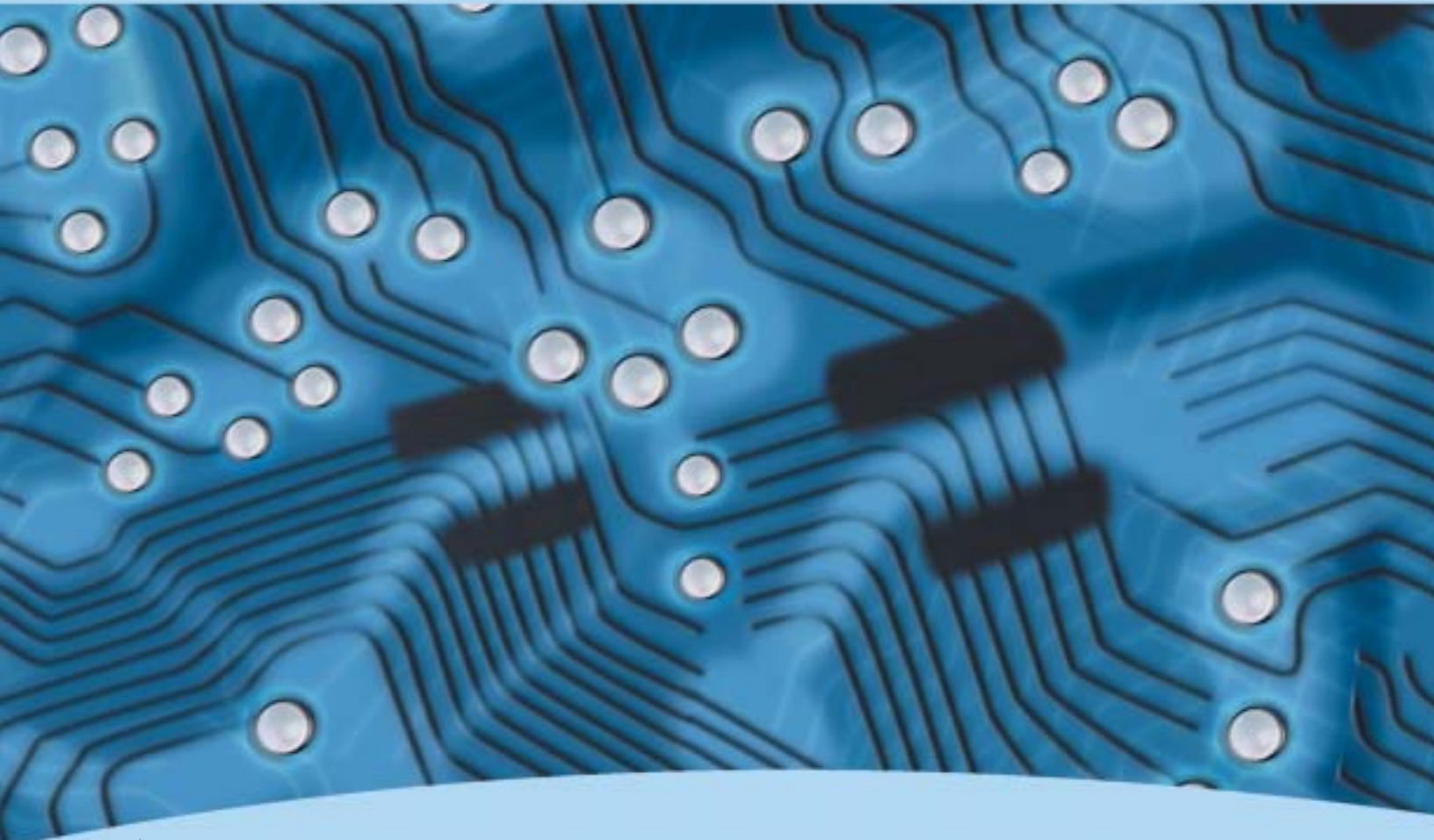

The new Emax range shines like a light from within: the new generation of trip units is fitted with the latest advances in electronics, offering individual bespoke solutions for control and protection. The new trip units, which are amazingly versatile and simple to use, offer important innovations, like the brand-new intuitive operator interface which allows complete control of the system with just a few simple keystrokes. Furthermore, there are new protections, new alarms and connection to handheld and laptop PCs using Bluetooth technology. The re-engineered hardware architecture allows flexible and precise configuration. With the new Emax it is no longer necessary to completely replace the trip unit - simply add the module which satisfies your requirements: a great advantage, both in terms of flexibility and customisation.





# New Emax. Ensured reliability.



*The new Emax have received innumerable international certifications and approval by the major shipping registers.*



Careful selection of materials, meticulous assembly and a rigorous testing stage make the new Emax an extremely reliable and sturdy product, able to withstand high dynamic and thermal stresses for longer than any other circuit breaker in its category. With the new standardized system of accessories studied and made for the new Emax, work becomes easier, convenient, safe and rapid. Furthermore, ABB puts a highly specialized and rapid customer assistance service at your disposal. The new Emax give you that pleasant feeling of security which only such a reliable product is able to do.



# Emax UL power circuit breakers

## Electrical characteristics



UL 1066		E1		E2			
<b>Levels of performance</b>		B-A		B-A	N-A	S-A L-A	
Frame size	[A]	800	1600	800	800	800	
	[A]	1200		1200	1200	1200	
	[A]			1600	1600	1600	
	[A]						
	[A]						
Capacity of neutral pole for four-pole circuit breakers	[%I <sub>n</sub> ]	100	100	100	100	100	
<b>Rated short circuit current</b>							
240 V	[kA]	42	42	65	85	200	
480 V	[kA]	42	42	50	85	200	
600 V	[kA]	42	42	50	65	130	
Rated short time current	[kA]	42	42	50	65	15	
<b>IEC 60947-2</b>		E1		E2			
<b>Levels of performance</b>		B N		B N S L			
Currents: rated uninterrupted current (at 40°C) I <sub>u</sub>	[A]	800	800	1600	1000	800	1250
	[A]	1000	1000	2000	1250	1000	1600
	[A]	1250	1250		1600	1250	
	[A]	1600	1600		2000	1600	
	[A]					2000	
	[A]						
	[A]						
Capacity of neutral pole for four-pole circuit breakers	[%I <sub>u</sub> ]	100	100	100	100	100	100
<b>Rated ultimate breaking capacity under short circuit I<sub>cu</sub></b>							
220/230/380/400/415 V	[kA]	42	50	42	65	85	130
440 V	[kA]	42	50	42	65	85	110
500/525 V	[kA]	36	36	42	55	65	85
660/690 V	[kA]	36	36	42	55	65	85
<b>Rated service breaking capacity under short circuit I<sub>cs</sub></b>							
220/230/380/400/415 V	[kA]	42	50	42	65	85	130
440 V	[kA]	42	50	42	65	85	110
500/525 V	[kA]	36	36	42	55	65	65
660/690 V	[kA]	36	36	42	55	65	65
Rated short time withstand current I <sub>cw</sub> (1s)	[kA]	42	50	42	55	65	10
<b>UL 1066 and IEC 60947-2</b>		E1		E2			
<b>Overall dimensions</b>							
Fixed: H = 418 mm/16.46 in; D = 302 mm/11.89 in							
W (3 poles/4 poles)	[mm]	296/386		296/386			
W (3 poles/4 poles)	[in]	11.65/15.2		11.65/15.2			
Draw out: H = 461 mm/18.15 in; D = 396.5 mm/15.61 in							
W (3 poles/4 poles)	[mm]	324/414		324/414			
W (3 poles/4 poles)	[in]	12.76/16.3		12.76/16.3			
<b>Weights</b> (circuit breaker complete with trip unit, RH terminals, CT, excluding accessories)							
Fixed							
3 poles/4 poles	[Kg]	45/54		50/61			
3 poles/4 poles	[lbs]	99/119		110/134			
Draw out							
3 poles/4 poles	[Kg]	70/82		78/93			
3 poles/4 poles	[lbs]	154/181		172/205			

(1) four poles only; (2) 100% neutral protection



15DC200079F001



15DC200079F001





15DC200079F001

E3					E4					E6			
N-A	S-A	H-A	V-A	L-A	S-A	H-A	V-A	L-A	H-A/f <sup>(1)</sup>	H-A	V-A	L-A	H-A/f <sup>(1)</sup>
2000	800	800	800	800	3000	3000	3000	2500	3000	4000	4000	4000	4000
2500	1200	1200	1200	1200	3200	3200	3200	3000	3200	5000	5000	5000	5000
3200	1600	1600	1600	1600	3600	3600	3600	3200	3600				
	2000	2000	2000	2000				3600					
	2500	2500	2500	2500									
	3200	3200	3200										
100	100	100	100	100	50	50	50	50	100	50	50	50	100
65	85	85	125	200	85	100	125	200	100	125	125	200	125
50	65	85	125	200	65	85	125	200	85	85	125	200	85
50	65	65	100	130	65	85	100	130	85	85	85	130	85
50	65	65	85	25	65	85	100	30	85	100	100	100	100

E3					E4					E6		
N	S	H	V	L	S	H	V	S/f <sup>(1)</sup>	H/f <sup>(1)</sup>	H	V	H/f <sup>(1)</sup>
2500	1000	800	800	2000	4000	3200	3200	4000	3200	4000	3200	4000
3200	1250	1000	1250	2500		4000	4000		4000	5000	4000	5000
	1600	1250	1600							6300	5000	6300
	2000	1600	2000								6300	
	2500	2000	2500									
	3200	2500	3200									
	3200											
100	100	100	100	100	50	50	50	100	100	50	50	100
65	75	100	130	130	75	100	150	80	100	100	150	100
65	75	100	130	110	75	100	150	80	100	100	150	100
65	75	100	100	85	75	100	130	75	100	100	130	100
65	75	85	100	85	75	85	100	75	100	100	100	100
65	75	85	100	130	75	100	150	80	100	100	125	100
65	75	85	100	110	75	100	150	80	100	100	125	100
65	75	85	85	65	75	100	130	75	100	100	100	100
65	75	85	85	65	75	85	100	75	100	100	100	100
65	75	75	85	15	75	100	100	80	85	85	85	100

E3		E4		E6	
404 / 530	566/656	746 <sup>(2)</sup>	782/908	1034 <sup>(2)</sup>	
15.91 / 20.82	22.28/25.83	29.37	30.79/35.78	40.71	
432 / 558	594/684	774 <sup>(2)</sup>	810/936	1062 <sup>(2)</sup>	
17.01 / 21.97	23.39/26.93	30.47	31.89/36.85	41.81	
66 / 80	97/117	125 <sup>(2)</sup>	140/160	185 <sup>(2)</sup>	
145 / 176	214/258	276	308/353	408	
104 / 125	147/165	200 <sup>(2)</sup>	210/240	275 <sup>(2)</sup>	
229 / 275	324/363	441	463/529	607	

# Circuit breakers in accordance with IEC 60947-2

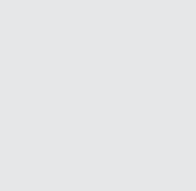
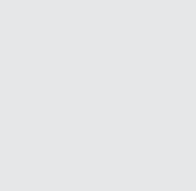
		E1		E2					
	<b>Automatic circuit-breakers</b>		<b>E1B</b>	<b>E1N</b>	<b>E2B</b>	<b>E2N</b>	<b>E2S</b>	<b>E2L</b>	
	Poles	[No.]	3 - 4		3 - 4				
	4p c.-b neutral current-carrying capacity	[% Iu]	100				100		
	<b>Iu</b>	(40 °C) [A]	800-1000-1250-1600	800-1000-1250-1600	1600-2000	1000-1250-1600-2000	800-1000-1250-1600-2000	1250-1600	
	<b>Ue</b>	[V~]	690	690	690	690	690	690	
	<b>Icu</b>	(220...415V) [kA]	42	50	42	65	85	130	
	<b>Ics</b>	(220...415V) [kA]	42	50	42	65	85	130	
	<b>Icw</b>	(1s) [kA]	42	50	42	55	65	10	
		(3s) [kA]	36	36	42	42	42	-	
	<b>Automatic circuit-breakers with full-size neutral conductor</b>								
Poles	[No.]	Standard version			Standard version				
4p c.-b neutral current-carrying capacity	[% Iu]								
<b>Iu</b>	(40 °C) [A]								
<b>Ue</b>	[V~]								
<b>Icu</b>	(220...415V) [kA]								
<b>Ics</b>	(220...415V) [kA]								
<b>Icw</b>	(1s) [kA]								
	(3s) [kA]								
	<b>Switch-disconnectors</b>		<b>E1B/MS</b>	<b>E1N/MS</b>	<b>E2B/MS</b>	<b>E2N/MS</b>	<b>E2S/MS</b>		
	Poles	[No.]	3 - 4	3 - 4	3 - 4	3 - 4	3 - 4		
	<b>Iu</b>	(40 °C) [A]	800-1000-1250-1600	800-1000-1250-1600	1600-2000	1000-1250-1600-2000	1000-1250-1600-2000		
	<b>Ue</b>	[V~]	690	690	690	690	690		
	<b>Icw</b>	(1s) [kA]	42	50	42	55	65		
		(3s) [kA]	36	36	42	42	42		
	<b>Icm</b>	(220...440V) [kA]	88.2	105	88.2	121	143		
		<b>Automatic circuit-breakers for applications up to 1150 V AC</b>				<b>E2B/E</b>	<b>E2N/E</b>		
Poles		[No.]			3 - 4	3 - 4			
<b>Iu</b>		(40 °C) [A]			1600-2000	1250-1600-2000			
<b>Ue</b>		[V~]			1150	1150			
<b>Icu</b>		(1150V) [kA]			20	30			
<b>Ics</b>		(1150V) [kA]			20	30			
	(1s) [kA]			20	30				
	<b>Switch-disconnectors for applications up to 1150 V AC</b>				<b>E2B/E MS</b>	<b>E2N/E MS</b>			
	Poles	[No.]			3 - 4	3 - 4			
	<b>Iu</b>	(40 °C) [A]			1600-2000	1250-1600-2000			
	<b>Ue</b>	[V~]			1150	1150			
	<b>Icw</b>	(1s) [kA]			20	30			
	<b>Icm</b>	(1000V) [kA]			40	63			
	<b>Switch-disconnectors for applications up to 1000 V DC</b>		<b>E1B/E MS</b>		<b>E2N/E MS</b>				
	Poles	[No.]	3 - 4		3 - 4				
	<b>Iu</b>	(40 °C) [A]	800-1250		1250-1600-2000				
	<b>Ue</b>	[V-]	750 (3p)-1000(4p)		750 (3p)-1000(4p)				
	<b>Icw</b>	(1s) [kA]	20		25				
	<b>Icm</b>	(750V) [kA]	42		52.5				
	(1000V) [kA]	42		52.5					
<b>Sectionalizing truck</b>			<b>E1 CS</b>	<b>E2 CS</b>					
<b>Iu</b>	(40 °C) [A]		1250	2000					
<b>Earthing switch with making capacity</b>			<b>E1 MTP</b>	<b>E2 MTP</b>					
<b>Iu</b>	(40 °C) [A]		1250	2000					
<b>Earthing truck</b>			<b>E1 MT</b>	<b>E2 MT</b>					
<b>Iu</b>	(40 °C) [A]		1250	2000					

(\*) The performance at 1000V is 50kA.

E3					E4			E6	
E3N	E3S	E3H	E3V	E3L	E4S	E4H	E4V	E6H	E6V
		3 - 4				3 - 4		3 - 4	
		100				50		50	
2500-3200	1000-1250-1600-2000-2500-3200	800-1000-1250-1600-2000-2500-3200	800-1250-1600-2000-2500-3200	2000-2500	4000	3200-4000	3200-4000	4000-5000-6300	3200-4000-5000-6300
690	690	690	690	690	690	690	690	690	690
65	75	100	130	130	75	100	150	100	150
65	75	85	100	130	75	100	150	100	125
65	75	75	85	15	75	100	100	100	100
65	65	65	65	-	75	75	75	85	85
					<b>E4S/f</b>	<b>E4H/f</b>	<b>E6H/f</b>		
Standard version					4	4	4		
					100	100	100		
					4000	3200-4000	4000-5000-6300		
					690	690	690		
					80	100	100		
					80	100	100		
					80	85	100		
					75	75	100		
<b>E3N/MS</b>	<b>E3S/MS</b>	<b>E3V/MS</b>			<b>E4S/MS</b>	<b>E4H/MS</b>	<b>E4H/f MS</b>	<b>E6H/MS</b>	<b>E6H/f MS</b>
3 - 4	3 - 4	3-4			3 - 4	3 - 4	4	3-4	4
2500-3200	1000-1250-1600-2000-2500-3200	800-1250-1600-2000-2500-3200			4000	3200-4000	3200-4000	4000-5000-6300	4000-5000-6300
690	690	690			690	690	690	690	690
65	75	85			75	100	85	100	100
65	65	65			75	75	75	85	85
143	165	286			165	220	220	220	220
<b>E3H/E</b>					<b>E4H/E</b>		<b>E6H/E</b>		
3 - 4					3 - 4		3 - 4		
1250-1600-2000-2500-3200					3200-4000		4000-5000-6300		
1150					1150		1150		
30 (*)					65		65		
30 (*)					65		65		
30 (*)					65		65		
<b>E3H/E MS</b>					<b>E4H/E MS</b>		<b>E6H/E MS</b>		
3 - 4					3 - 4		3 - 4		
1250-1600-2000-2500-3200					3200-4000		4000-5000-6300		
1150					1150		1150		
50					65		65		
105					143		143		
<b>E3H/E MS</b>					<b>E4H/E MS</b>		<b>E6H/E MS</b>		
3 - 4					3 - 4		3 - 4		
1250-1600-2000-2500-3200					3200-4000		4000-5000-6300		
750 (3p)-1000(4p)					750 (3p) - 1000 (4p)		750 (3p) - 1000 (4p)		
40					65		65		
105					143		143		
105					143		143		
<b>E3 CS</b>					<b>E4 CS</b>		<b>E6 CS</b>		
3200					4000		6300		
<b>E3 MTP</b>					<b>E4 MTP</b>		<b>E6 MTP</b>		
3200					4000		6300		
<b>E3 MT</b>					<b>E4 MT</b>		<b>E6 MT</b>		
3200					4000		6300		









# Main characteristics

## Contents

<b>Emax UL circuit breakers</b> .....	1/2
<b>Emax UL switches</b> .....	1/4
<b>Construction characteristics</b>	
Structure of the circuit breakers .....	1/6
Operating mechanism .....	1/7
Operating and signaling parts .....	1/8
Cradles of draw out circuit breakers .....	1/9
Circuit breaker components .....	1/10
<b>Versions and connections</b> .....	1/11
<b>Electronic trip units</b>	
General characteristics .....	1/12
UL versions available .....	1/13
Rating plugs .....	1/15
<b>Compliance with Standards</b>	
Standards, approvals, certifications and company quality system .....	1/16
A design dedicated to quality and respect for the environment .....	1/17

# Emax UL circuit breakers

## Common data

Voltages		
Rated maximum voltage	[V]	635
Rated voltage	[V]	600
Test voltage (1 min. 50/60 Hz)	[kV]	2.2
Frequency		
	[Hz]	50 - 60
Number of poles		
		3 - 4
Version		
		Fixed (F) - Draw out (W)



		E1		E2		
		B-A	B-A	N-A	S-A	L-A
<b>Level of performance</b>		B-A	B-A	N-A	S-A	L-A
<b>Currents</b>						
<b>Frame size</b>	[A]	<b>800</b>	<b>1600</b>	<b>800</b>	<b>800</b>	<b>800</b>
	[A]	<b>1200</b>		<b>1200</b>	<b>1200</b>	<b>1200</b>
	[A]			<b>1600</b>	<b>1600</b>	<b>1600</b>
	[A]					
	[A]					
	[A]					
Capacity of neutral pole for four-pole circuit breakers	[%Iu]	100	100	100	100	100
<b>Rated short circuit current</b>						
240 V	[kA]	42	42	65	85	200
480 V	[kA]	42	42	50	85	200
600 V	[kA]	42	42	50	65	130
<b>Rated short time current</b>	[kA]	42	42	50	65	15
<b>Trip units</b>						
PR121/P		■	■	■	■	■
PR122/P		■	■	■	■	■
PR123/P		■	■	■	■	■
<b>Trip times</b>						
Make time (max)	[ms]	80	80	80	80	80
Break time (I<ST current) (max)	[ms]	70	70	70	70	70
Break time (I>ST current) (max)	[ms]	30	30	30	30	12
<b>Overall dimensions</b>						
Fixed: H = 418 mm/16.46 in - D = 302 mm/11.89 in						
W (3 poles/4 poles)	[mm]	296/386		296/386		
W (3 poles/4 poles)	[in]	11.65/15.2		11.65/15.2		
Draw out: H = 461 mm/18.15 in - D = 396.5 mm/15.61 in						
W (3 poles/4 poles)	[mm]	324/414		324/414		
W (3 poles/4 poles)	[in]	12.76/16.3		12.76/16.3		
<b>Weights</b> (Circuit breaker complete with trip unit, RH terminals, CT, excluding accessories)						
Fixed						
3 poles/4 poles	[kg]	45/54		50/61		
3 poles/4 poles	[lbs]	99/119		110/134		
Draw out						
3 poles/4 poles	[kg]	70/82		78/93		
3 poles/4 poles	[lbs]	154/181		172/205		

\* four poles only.

		E1 B-A		E2 B-A / N-A / S-A / L-A		
		800	1200	800	1200	1600
<b>Continuous current rating Iu</b>	[A]	<b>800</b>	<b>1200</b>	<b>800</b>	<b>1200</b>	<b>1600</b>
<b>Mechanical life</b> with regular ordinary maintenance	[No. Operations x 1000]	20	20	20	20	20
Operation frequency	[Operations/hour]	30	30	30	30	30
<b>Electrical life</b>	[No. Operations x 1000]	10	10	10	10	10
Operation frequency	[Operations/hour]	30	30	30	30	30



1SDC200078F0001



1SDC200079F0001



1SDC200080F0001

1

E3						E4					E6				
N-A	S-A	H-A	V-A	L-A		S-A	H-A	V-A	L-A	H-A/f*		H-A	V-A	L-A	H-A/f*
2000	800	800	800	800		3000	3000	3000	2500	3000		4000	4000	4000	4000
2500	1200	1200	1200	1200		3200	3200	3200	3000	3200		5000	5000	5000	5000
3200	1600	1600	1600	1600		3600	3600	3600	3200	3600					
	2000	2000	2000	2000					3600						
	2500	2500	2500	2500											
	3200	3200	3200												
100	100	100	100	100		50	50	50	50	100		50	50	50	100
65	85	85	125	200		85	100	125	200	100		125	125	200	125
50	65	85	125	200		65	85	125	200	85		85	125	200	85
50	65	65	100	130		65	85	100	130	85		85	85	150	85
50	65	65	85	25		65	85	100	30	85		100	100	100	100
■	■	■	■	■		■	■	■	■	■		■	■	■	■
■	■	■	■	■		■	■	■	■	■		■	■	■	■
■	■	■	■	■		■	■	■	■	■		■	■	■	■
80	80	80	80	80		80	80	80	80	80		80	80	80	80
70	70	70	70	70		70	70	70	70	70		70	70	70	70
30	30	30	30	12		30	30	30	30	30		30	30	30	30
		404/530						566/656		746			782/908		1034
		15.91/20.82						22.28/25.83		29.37			30.79/35.78		40.71
		432/558						594/684		774			810/936		1062
		17.01/21.97						23.39/26.93		30.47			31.89/36.85		41.81
		66/80						97/117		125			140/160		185
		145/176						214/258		276			308/353		408
		104/125						147/165		200			210/240		275
		229/275						324/363		441			463/529		607

E3 N-A / S-A / H-A / V-A / L-A						E4 S-A / H-A / V-A / L-A / H-A/f				E6 H-A / V-A / L-A / H-A/f	
800	1200	1600	2000	2500	3200	3000	3200	3600		4000	5000
15	15	15	15	15	15	8	8	8		8	8
30	30	30	30	30	30	30	30	30		30	30
10	10	10	8	8	8	5	5	5		5	3
30	30	30	30	30	30	30	30	30		30	30



# Emax UL switches

The switches share the same frames and accessories as the circuit breakers, with the only difference the absence of the trip unit.

The switch is available in both three-pole and four-pole fixed and draw out version and is identified by the code "/MS" (on the label). The electrical characteristics of the switches are given in the following table.

1



		E1B-AMS
<b>Frame size</b>	[A]	<b>800</b>
	[A]	<b>1200</b>
	[A]	
	[A]	
Number of poles		3/4
Capacity of neutral pole for four-pole circuit breakers [%Iu]		100
Rated voltage	[V]	600
Rated maximum voltage	[V]	635
Test voltage (1 min. 50/60 Hz)	[kV]	2.2
Frequency	[Hz]	50-60
<b>Rated short time current</b>	<b>[kA]</b>	<b>35</b>
Version		F - W



	E2B-A/MS	E2N-A/MS	E2S-A/MS	E3N-A/MS	E3S-A/MS	E3V-A/MS	E4S-A/MS	E4H-A/MS	E6H-A/MS
	1600	800	800	2000	800	800	3000	3000	4000
		1200	1200	2500	1200	1200	3200	3200	5000
		1600	1600		1600	1600	3600	3600	
					2000	2000			
					2500	2500			
	3/4	3/4	3/4	3/4	3/4	3/4	3/4	3/4	3/4
	100	100	100	100	100	100	50	50	50
	600	600	600	600	600	600	600	600	600
	635	635	635	635	635	635	635	635	635
	2.2	2.2	2.2	2.2	2.2	2.2	2.2	2.2	2.2
	50-60	50-60	50-60	50-60	50-60	50-60	50-60	50-60	50-60
	42	50	65	50	65	85	65	85	100
	F - W	F - W	F - W	F - W	F - W	F - W	F - W	F - W	F - W



## Construction characteristics

### Structure of the circuit breakers

The sheet steel structure of the circuit breaker is extremely compact, considerably reducing overall dimensions.

Safety is improved by adopting double insulation for the live parts and total segregation between phases.

The sizes have the same height and depth for all of the circuit breakers in each version.

The depth of the draw out version allows installation of switchboards and switchgears 500 mm/19.68 in deep.

The width of 324 mm/12.75 in (up to 2000 A) in the draw out version allows the equipment to be used in switchboard compartments 400 mm/15.74 in wide. The compact dimensions also allow them to replace power circuit breakers of any size from earlier series.

1

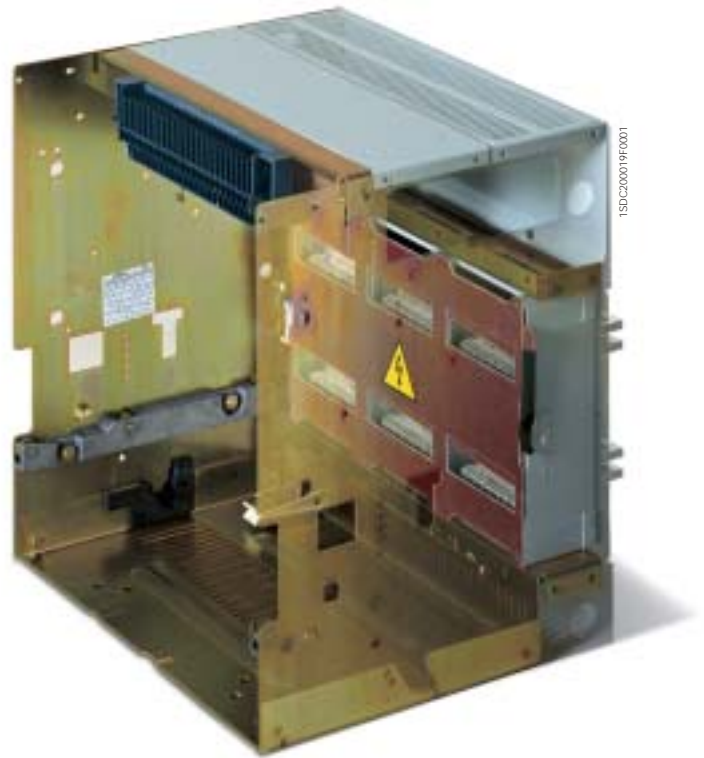

1SDC200018F0001

1SDC200018F0001



# Construction characteristics

## Operating mechanism

A stored energy type operating mechanism is used. The springs are charged manually by operating the front lever or using a geared motor, supplied on request. The opening springs are charged automatically during the closing operation. When closing coil, shunt trip and motor operator are installed, the circuit breaker can be operated by remote control and, if required, managed by a supervision and control system.

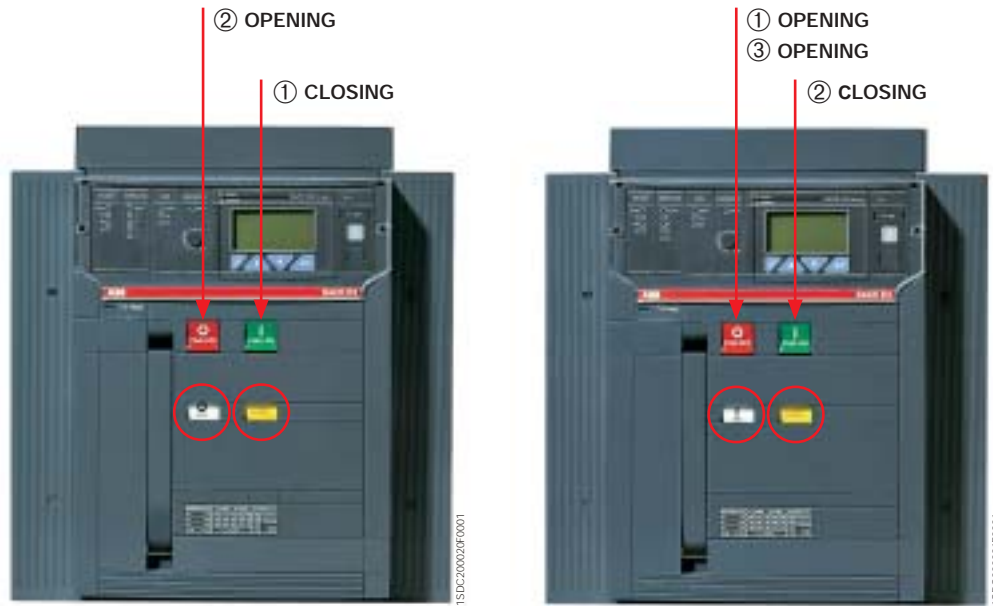

The following operating cycles are possible without recharging the springs:

- starting with the circuit breaker open (0) and the springs charged:  
closing-opening
- starting with the circuit breaker closed (I) and the springs charged:  
opening-closing-opening.

The same operating mechanism is used for the entire series and is fitted with a mechanical and electrical anti-pumping device.



# Construction characteristics

## Operating and signaling parts

1

### Fixed version

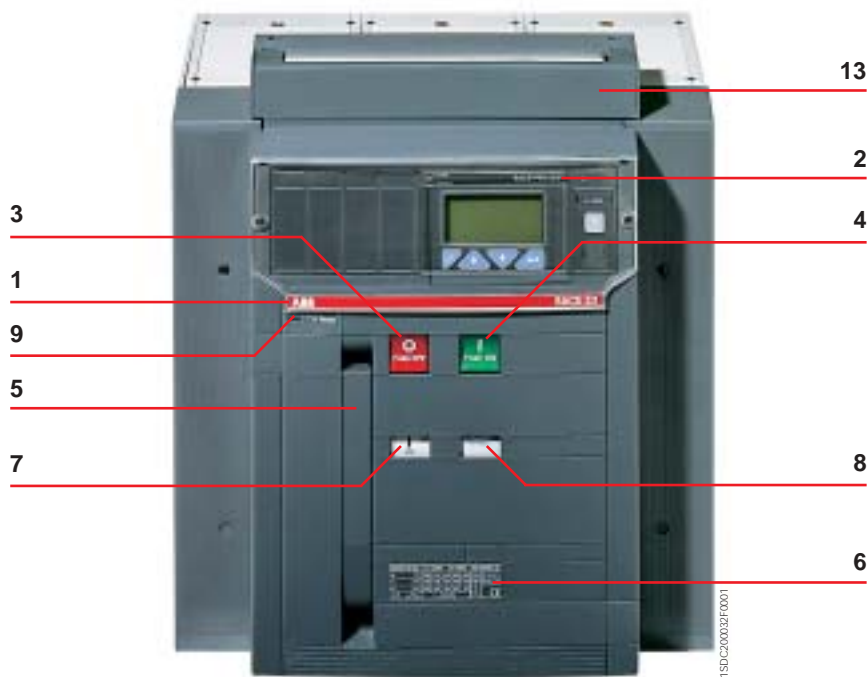

#### Caption

- 1 Trademark and size of circuit breaker
- 2 PR121, PR122 or PR123 Trip units
- 3 Pushbutton for manual opening
- 4 Pushbutton for manual closing
- 5 Lever to manually charge closing springs
- 6 Label with electrical characteristics
- 7 Mechanical device to signal circuit breaker open "O" and closed "I"
- 8 Signal for springs charged or discharged
- 9 Mechanical indication of trip
- 10 Key lock in open position
- 11 Key lock and padlock in racked-in/racked-out position (for draw out version only)
- 12 Racking-in/racking out device (for draw out version only)
- 13 Terminal box (for fixed version only)
- 14 Sliding contacts (for draw out version only)
- 15 Circuit breaker position indicator: connected/ isolated for test/racked-out (for draw out version only)

### Draw out version

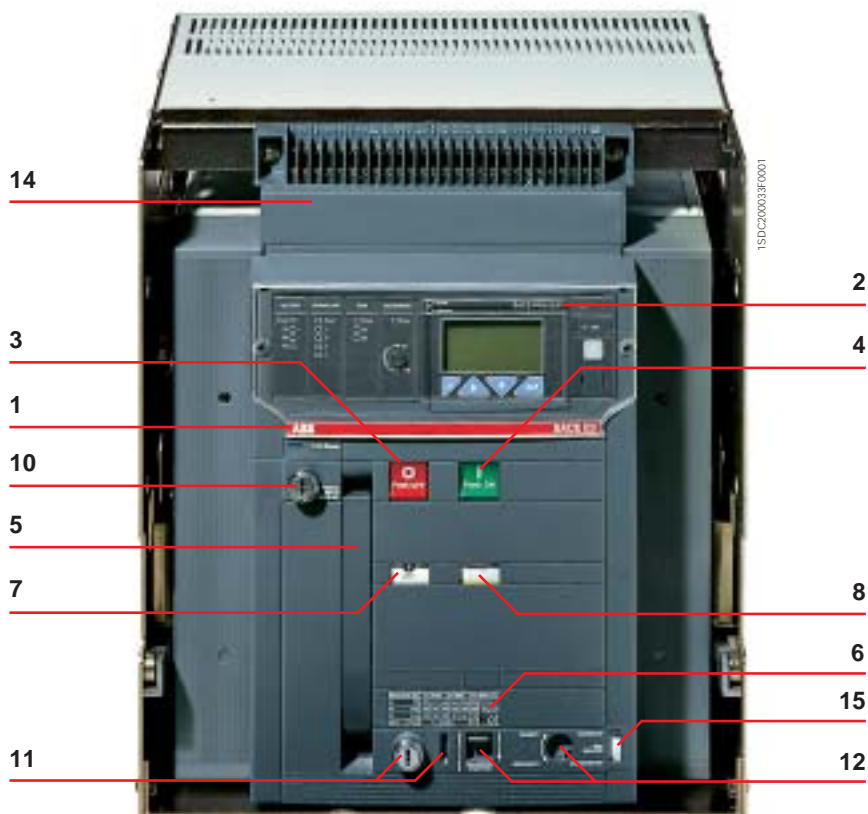

#### Note:

"Connected" refers to the position in which both the power contacts and auxiliary contacts are connected; "racked-out" is the position in which both the power contacts and auxiliary contacts are disconnected; "isolated for test" is the position in which the power contacts are disconnected, while the auxiliary contacts are connected.





# Construction characteristics

## Cradles of draw out circuit breakers

The cradles of draw out circuit breakers have shutters for segregating the fixed contacts when the circuit breaker is racked out of the compartment. These can be locked in their closed position using padlock devices.

Caption	
1	Sheet steel supporting structure
2	Single grounding pliers mounted on the left for E1, E2 and E3, double grounding pliers for E4 and E6
3	Safety shutters
4	Terminal support base
5	Terminals
6	Contacts signaling that the circuit breaker is connected, isolated for test, racked-out
7	Sliding contacts
8	Padlock device for safety shutters (on request)
9	Fixing points (4 for E1, E2, E3 and 6 for E4, E6)

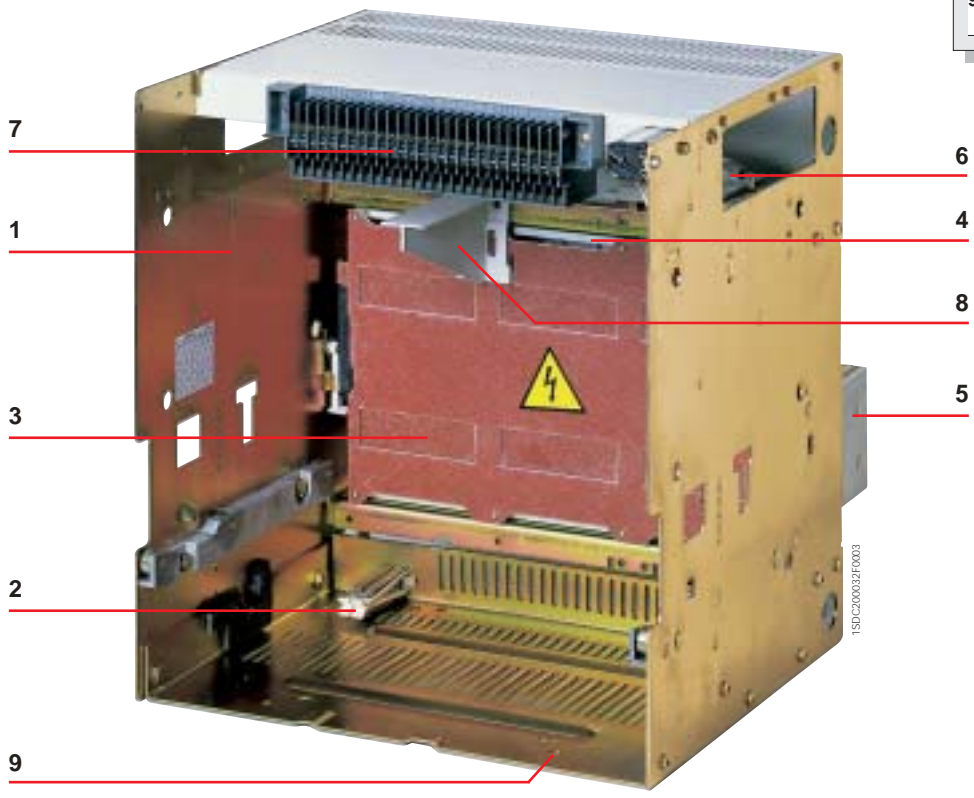



# Construction characteristics

## Circuit breaker components

1

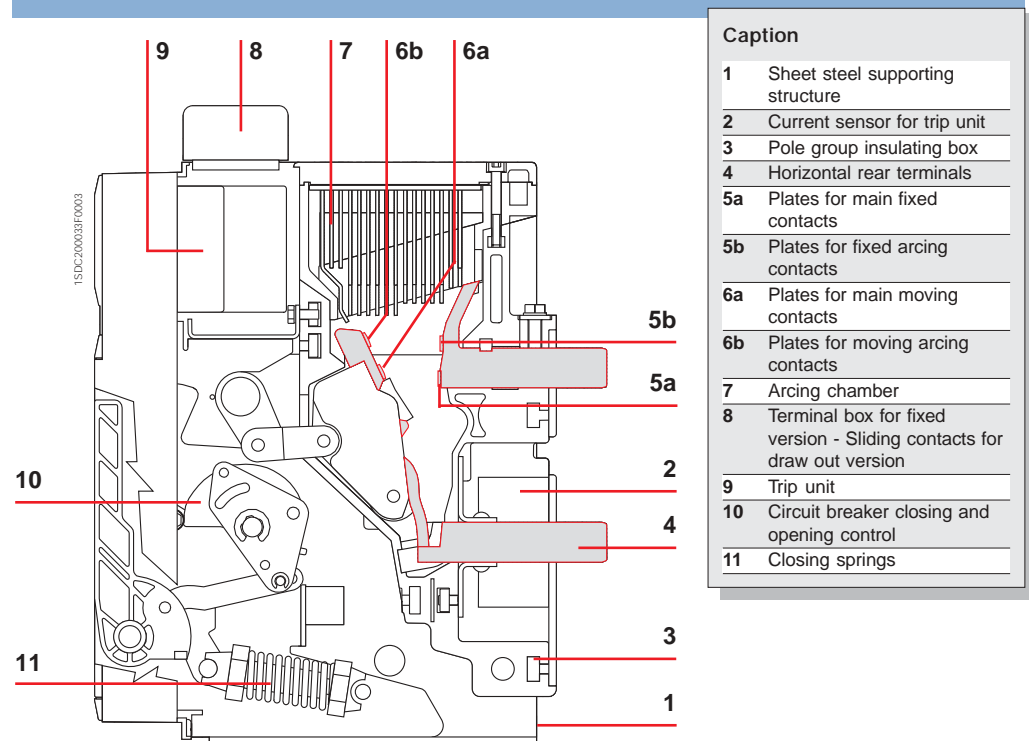

Caption	
1	Sheet steel supporting structure
2	Current sensor for trip unit
3	Pole group insulating box
4	Horizontal rear terminals
5a	Plates for main fixed contacts
5b	Plates for fixed arcing contacts
6a	Plates for main moving contacts
6b	Plates for moving arcing contacts
7	Arcing chamber
8	Terminal box for fixed version - Sliding contacts for draw out version
9	Trip unit
10	Circuit breaker closing and opening control
11	Closing springs

**Versions:** E1 B-A/N-A, E2 B-A/N-A/H-A, E3 N-A/S-A/H-A/V-A, E4 S-A/H-A/V-A/L-A, E6 H-A/V-A/L-A

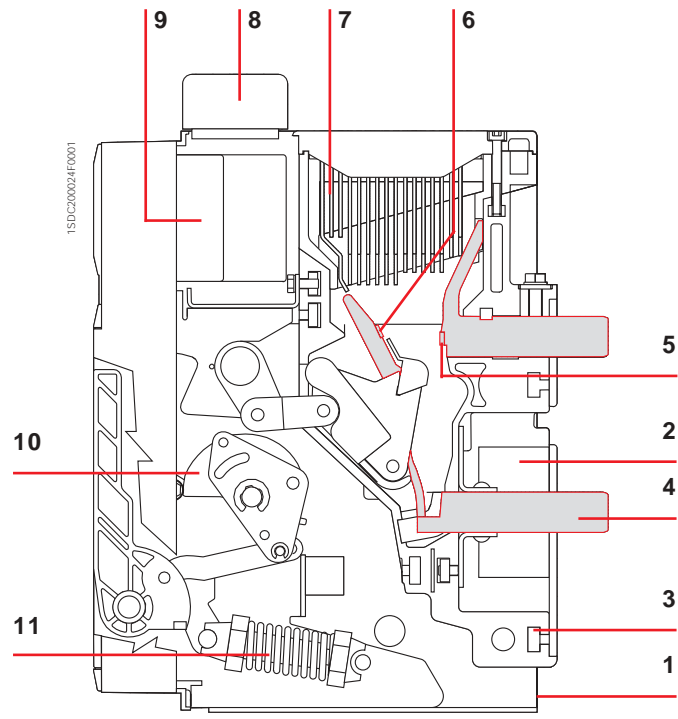

**Versions:** E2 L-A, E3 L-A



## Versions and connections

All circuit breakers are available in fixed and draw out, three pole or four-pole versions.

Each series of circuit breakers offers terminals made of silver-plated copper bars in the same sizes, regardless of the continuous current ratings of the circuit breakers (except for E3).

The cradles for draw out circuit breakers are common to each size, regardless of the continuous current rating and interrupting rating of the relative moving parts (except for E3 and E2S).

The availability of various types of terminals makes it possible to build switchboards against the wall, or switchboards to be accessed from behind with rear connections.

For special installation needs, the circuit breakers may be fitted with various combinations of upper and lower terminals.

The following terminals are also available in the IEC version: front for fixed and draw version and flat for draw out version.

### Fixed circuit breaker

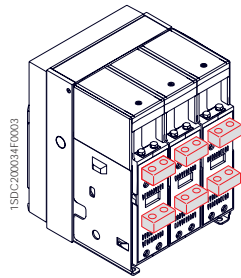

Horizontal rear terminals

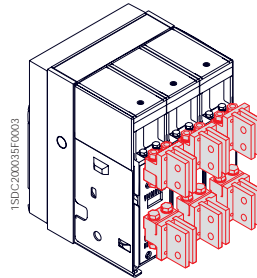

Vertical rear terminals

### Draw out circuit breaker

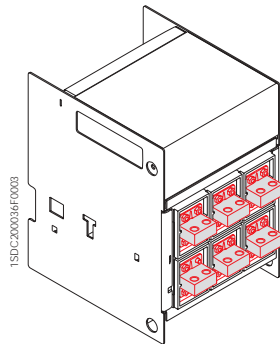

Horizontal rear terminals

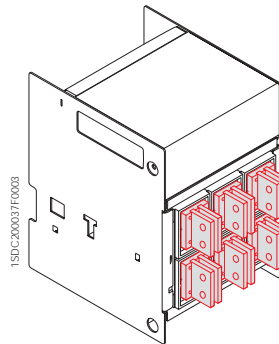

Vertical rear terminals



# Electronic trip units

## General characteristics

The overcurrent protection for AC installations uses three types of electronic trip unit series: PR121, PR122 and PR123.

The basic series, PR121, offers the whole set of standard protection functions, complete with a user-friendly interface.

It allows discrimination of which fault caused the trip by means of the new led indications.

PR122 and PR123 trip units are of new concept modular architecture. It is now possible to have a complete series of protections, accurate measurements, signalling or dialogue functions, designed and customisable for all application requirements.

The protection system consists of:

- 3 or 4 new generation current sensors (Rogowsky coil);
- external current sensors (i.e. for external neutral, residual current or source ground return protection);
- a protection unit selected among PR121/P, PR122/P or PR123/P with optional communication module via Modbus or Fieldbus plug network (PR122/P and PR123/P only), as well as via a wireless connection;
- an opening solenoid, which acts directly on the circuit breaker operating mechanism (supplied with the protection unit).





# Electronic trip units

## UL Versions available

General characteristics of the electronic trip units:

- operation without the need for an external power supply
- microprocessor technology
- high precision
- true R.M.S. measurements of the current values
- trip cause indication and trip data recording
- interchangeability among all types of trip units
- setting for neutral configurable:
  - OFF-50%-100%-200% of phase setting for circuit breakers E1, E2, E3 and E4/f, E6/f full-size versions, and E4-E6 with external neutral protection;
  - OFF-50% for standard E4 and E6.

The main performance features of the trip units are listed below.

### SACE PR121



Protection

PR121/P	PR121/P	PR121/P
<b>L I</b>	<b>L S I</b>	<b>L S I G</b>

### SACE PR122



Protection

PR122/P	PR122/P	PR122/P	PR122/P
<b>L I</b>	<b>L S I</b>	<b>L S I G</b>	<b>L S I G Rc</b>

For all versions **U OT M**

**New modules available:**

Measuring	opt.	<b>UV OV RV RP UF OF</b>
Communication	opt.	
Signaling	opt.	
Bluetooth (wireless link)	opt.	

### SACE PR123



Protection

PR123/P	PR123/P
<b>L S I</b>	<b>L S I G</b>

For all versions **OT D U UV OV RV RP M UF OF**

**New modules available:**

Communication	opt.	
Signaling	opt.	
Bluetooth (wireless link)	opt.	

# Electronic trip units

UL Versions available

## Features

Protection functions	PR121	PR122	PR123
<b>L</b> Protection against overload with inverse long time-delay trip	■	■	■
<b>S</b> Selective protection against short circuit inverse or definite short time-delay trip	■	■	■
<b>S</b> Second selective protection against short circuit inverse or definite short time-delay trip			■
<b>I</b> Protection against instantaneous short circuit with adjustable trip current threshold	■	■	■
<b>G</b> Protection against ground fault		residual	■
		source ground return	■
<b>Rc</b> Residual current		opt.	opt.
<b>D</b> Protection against directional short circuit with adjustable time-delay			■
<b>U</b> Protection against phase unbalance		■	■
<b>OT</b> Protection against overtemperature (check)		■	■
<b>UV</b> Undervoltage protection		opt. <sup>(1)</sup>	■
<b>OV</b> Overvoltage protection		opt. <sup>(1)</sup>	■
<b>RV</b> Residual voltage protection		opt. <sup>(1)</sup>	■
<b>RP</b> Reverse active power protection		opt. <sup>(1)</sup>	■
<b>M</b> Thermal memory for functions L and S		■	■
<b>UF</b> Underfrequency protection		opt. <sup>(1)</sup>	■
<b>OF</b> Overfrequency protection		opt. <sup>(1)</sup>	■
<b>Measurements</b>			
Currents (phases, neutral, ground fault)		■	■
Voltage (phase-phase, phase-neutral, residual)		opt. <sup>(1)</sup>	■
Power (active, reactive, apparent)		opt. <sup>(1)</sup>	■
Power factor		opt. <sup>(1)</sup>	■
Frequency and peak factor		opt. <sup>(1)</sup>	■
Energy (active, reactive, apparent, meter)		opt. <sup>(1)</sup>	■
Harmonics analysis (display of wave forms and harmonics module)			■
<b>Event marking and maintenance data</b>			
Event marking with the instant it occurred	opt. <sup>(2)</sup>	■	■
Chronological event storage	opt. <sup>(2)</sup>	■	■
Electrical operations counter and contact wear		■	■
<b>Communication with supervision system and centralised control (IEC only)</b>			
Remote setting of the protection functions parameter, unit configuration, communication		opt. <sup>(3)</sup>	opt. <sup>(3)</sup>
Transmission of measurements, states and alarms from circuit breaker to system		opt. <sup>(3)</sup>	opt. <sup>(3)</sup>
Transmission of events and maintenance data from circuit breaker to system		opt. <sup>(3)</sup>	opt. <sup>(3)</sup>
<b>Watchdog</b>			
Alarm and trip for release overtemperature		■	■
Check of trip status	■	■	■
<b>Interface with the user</b>			
Presetting by means of dip switches	■		
Presetting by means of keys and LCD viewer		■	■
Alarm signals for functions L, S, I and G	■	■	■
Alarm signal of one of the following protections: undervoltage, overvoltage, residual voltage, reverse power, phase unbalance, overtemperature		opt. <sup>(1)</sup>	■
Complete management of pre-alarms and alarms for all the self-control protection functions		■	■
Enabling password for use with consultation in "READ" mode or consultation and setting in "EDIT" mode		■	■
<b>Load control</b>			
Load connection and disconnection according to the current passing through the circuit breaker		■	■
<b>Zone discrimination</b>			
Can be activated for protection functions S, G and (PR123 only) D		■	■

(1) with PR120V; (2) with BT030 communication unit; (3) with PR120/D-M (IEC only)



# Electronic trip units

## Rating plugs

1

### Rating plugs

Type of circuit breaker	Rated current I <sub>n</sub>	I <sub>n</sub> [A]												
		250	400	800	1000	1200	1600	2000	2500	3000	3200	3600	4000	5000
E1B-A	800													
	1200													
E2B-A	1600													
	1600													
E2N-A	800													
	1200													
	1600													
E2S-A	800													
	1200													
	1600													
E2L-A	800													
	1200													
	1600													
E3N-A	2000													
	2500													
	3200													
E3S-A	800													
	1200													
	1600													
	2000													
	2500													
	3200													
E3H-A	800													
	1200													
	1600													
	2000													
	2500													
	3200													
E3V-A	800													
	1200													
	1600													
	2000													
	2500													
	3200													
E3L-A	800													
	1200													
	1600													
	2000													
	2500													
E4S-A	3000													
	3200													
	3600													
E4H-A	3000													
	3200													
	3600													
E4V-A	3000													
	3200													
	3600													
E4L-A	2500													
	3000													
	3200													
	3600													
E6H-A	4000													
	5000													
E6V-A	4000													
	5000													
E6L-A	4000													
	5000													



# Compliance with Standards

## Standards, approvals, certifications and company quality System

The Emax power circuit breakers conform with the ANSI C37.13, C37.16, C37.17 and C37.50 Standards and are UL 1066 certified.

The UL 1066 certification allows Emax to be used in UL 1558 switchgears, gear UL891 Low Voltage switchboards and CSA C22.2 no. 31 Switchgear Assemblies.

All the Emax circuit breakers and their accessories are also available in the versions complying with the International IEC 60947, EN 60947 (harmonized in 28 CENELEC countries), CEI EN 60947 and IEC 61000 Standards and conform with the following EC directives:

- "Low Voltage Directive" (LVD) nr. 73/23 EEC
- "Electromagnetic Compatibility Directive" (EMC) nr. 89/336 EEC.

The main versions of the equipment are approved by the following Shipping Registries:

- ABS (American Bureau of Shipping)
- RINA (Italian Shipping Register)
- Det Norske Veritas
- Bureau Veritas
- Germanischer Lloyd
- Lloyd's Register of Shipping
- Polskj Reiestr Statkow
- Gost
- NK

Certification of conformity with the aforementioned product Standards is carried out in compliance with the EN 45011 European Standard by the Italian certification body ACAE (Associazione per la Certificazione delle Apparecchiature Elettriche - Association for Certification of Electrical Equipment), recognized by the European organization LOVAG (Low Voltage Agreement Group).



**Note:** Contact ABB for a list of approved types of circuit breakers, approved performance data and the corresponding validity



1





## Compliance with Standards

A design dedicated to quality and respect for the environment

Quality has always been the leading commitment of ABB. This commitment involves every function of the company, and has allowed us to achieve prestigious recognition internationally.

The company's Quality System is certified by RINA, one of the most prestigious international certification bodies, and complies with ISO 9001 Standards; the ABB test facility is accredited by SINAL; the plants in Frosinone, Patrica, Vittuone and Garbagnate Monastero are also certified in compliance with OHSAS 18001 Standards for health and safety in the workplace.

ABB SACE, Italy's first industrial company in the electro-mechanical sector to achieve this, has been able to reduce its raw material consumption and machining scrap by 20% thanks to an ecology-orientated revision of its manufacturing process. All of the company's Divisions are involved in streamlining raw material and energy consumption, preventing pollution, limiting noise pollution and reducing scrap resulting from manufacturing processes, as well as to carrying out periodic environmental audits of its leading suppliers.

ABB is committed to environmental protection, as is also evidenced by the Life Cycle Assessments (LCA) of products carried out at the Research Center: this means assessment and improvement of the environmental performance of products throughout their life cycle are included right from the initial design engineering stage. The materials, processes and packaging used are chosen with a view to optimizing the actual environmental impact of each product, including its energy efficiency and recyclability.



1



# Emax





## Contents

### Installation in switchboards and switchgears

Modular design .....	2/2
Selecting the type of circuit breaker .....	2/3



---

## Installation in switchboards and switchgears

### Modular design

---

To allow easier installation and integration in Low Voltage switchgears and switchboards, the Emax series have been built with a modular design criteria, thanks to the same depth and height for all the sizes, as well as a significant reduction in their overall installation dimensions.

The front shield of the circuit breaker is identical for the entire series. This simplifies the construction of the switchboard doors since only one type of cut out is required and makes the front of the switchboards and switchgears the same for all sizes.

2



15DC20002F0001



---

# Installation in switchboards and switchgears

## Selecting the type of circuit breaker

---

---

### Number of poles

The choice of the number of poles for circuit breakers that simultaneously provide switching, protection and isolation functions in three-phase installations depends on the type of electrical system and the type of utilization or, more generally, whether it includes neutral.

2

---

### Fixed or draw out version

The fixed version of the circuit breaker is more compact in size than the draw out version. It is recommended for installations that can tolerate service interruptions in the event of faults or routine maintenance.

The draw out version of the circuit breaker is recommended for:

- applications that can only tolerate brief interruptions due to faults or routine maintenance.
- dual lines, one of which is a standby for the other, with a single circuit breaker for each pair.





---

# Installation in switchboards and switchgears

## Selecting the type of circuit breaker

---

2

---

### Connecting the main circuit breaker circuits

When designing switchboards, one must always keep in mind the problem of making the most rational connections between the circuit breaker and main busbar system.

The Emax series offers a range of options to satisfy different circuit breaker connection requirements.

The figures below provide some indications for terminal selection.

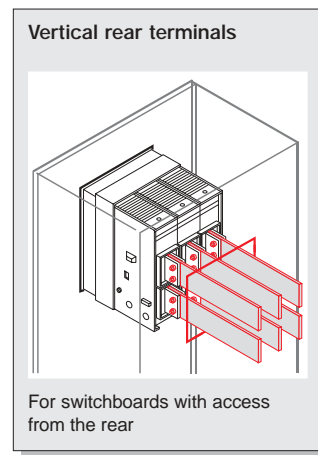
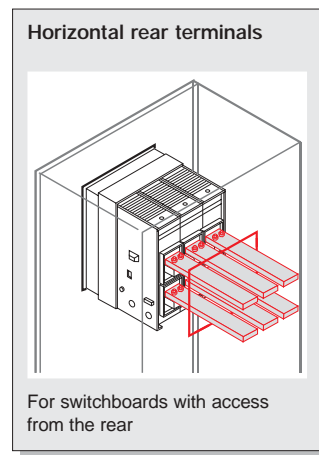

## Power losses

The following table provides the power loss for fixed and draw out circuit breakers.

Power loss			
Circuit breaker	I <sub>u</sub> [A]	Fixed 3/4 poles [W]	Withdrawable 3/4 poles [W]
<b>E1B-A</b>	800	65	95
	1200	138	212
	1600	253	378
<b>E2B-A/N-A/S-A</b>	1200	65	120
	1600	115	215
	2000	180	330
<b>E2L-A</b>	800	43	68
	1200	96	149
	1600	170	270
<b>E3N-A/S-A/H-A/V-A</b>	1200	55	83
	1600	85	150
	2000	130	225
	2500	205	350
	3200	330	570
<b>E3L-A</b>	800	34	53
	1200	77	119
	1600	138	211
	2000	214	330
	2500	336	516
<b>E4S-A/H-A/V-A</b>	3000	207	374
	3200	230	422
	3600	292	535
<b>E4L-A</b>	2500	208	330
	3000	299	475
	3200	340	541
	3600	430	684
	4000	515	837
<b>E6H-A/V-A</b>	4000	265	445
	5000	415	700
<b>E6L-A</b>	4000	432	656
	5000	675	1025

**Note**

The values indicated refer to balanced loads, with a current equal to the circuit breaker rating, and automatic circuit breakers.

## Derating in altitude

Emax power circuit breakers do not undergo any changes in their rated performance up to an altitude of 6600 ft (2000 meters).

As the altitude increases the atmospheric properties alter in terms of composition, dielectric capacity, cooling power and pressure.

The performance of the circuit breakers therefore undergoes derating which can be measured through the variation in significant parameters, such as the maximum rated operating voltage and the rated uninterrupted current.

The table below shows the values in relation to altitude.

Altitude	[ft]	<6600	9900	13200	16500
	[m]	2000	3000	4000	5000
Rated service voltage	<b>U<sub>e</sub></b> [V]	600	600	500	440
Continuous current rating	<b>I<sub>n</sub></b> [A]	I <sub>n</sub>	0.98xI <sub>n</sub>	0.93xI <sub>n</sub>	0.90xI <sub>n</sub>





# Emmax





# Electronic trip units and related accessories

## Contents

### Trip units and trip curves

PR121/P .....	3/2
PR122/P .....	3/9
PR123/P .....	3/23

### Accessories for trip units

PR120/K Internal Module .....	3/34
PR120/V Measurement Module .....	3/34
PR120/D-M Communication Module (IEC only) .....	3/35
PR120/D-BT Wireless Communication Module .....	3/35
BT030 .....	3/35
PR030/B power supply unit .....	3/35
HMI030 .....	3/35
PR010/T configuration test unit .....	3/36

### Communication devices

PR021/K signaling unit .....	3/37
SD-Pocket .....	3/39



# Trip units and trip curves

## PR121/P

### Characteristics

PR121/P is the new basic and complete trip unit for the Emax series. The complete range of protection functions together with the wide combination of thresholds and trip times offered make it suitable for protecting a wide range of alternating current installation. In addition to protection functions the unit is provided with multifunction LED indicators. Furthermore, PR121/P allows connection to external devices enhancing its advanced characteristics like remote signaling and monitoring, or remote supervision display.

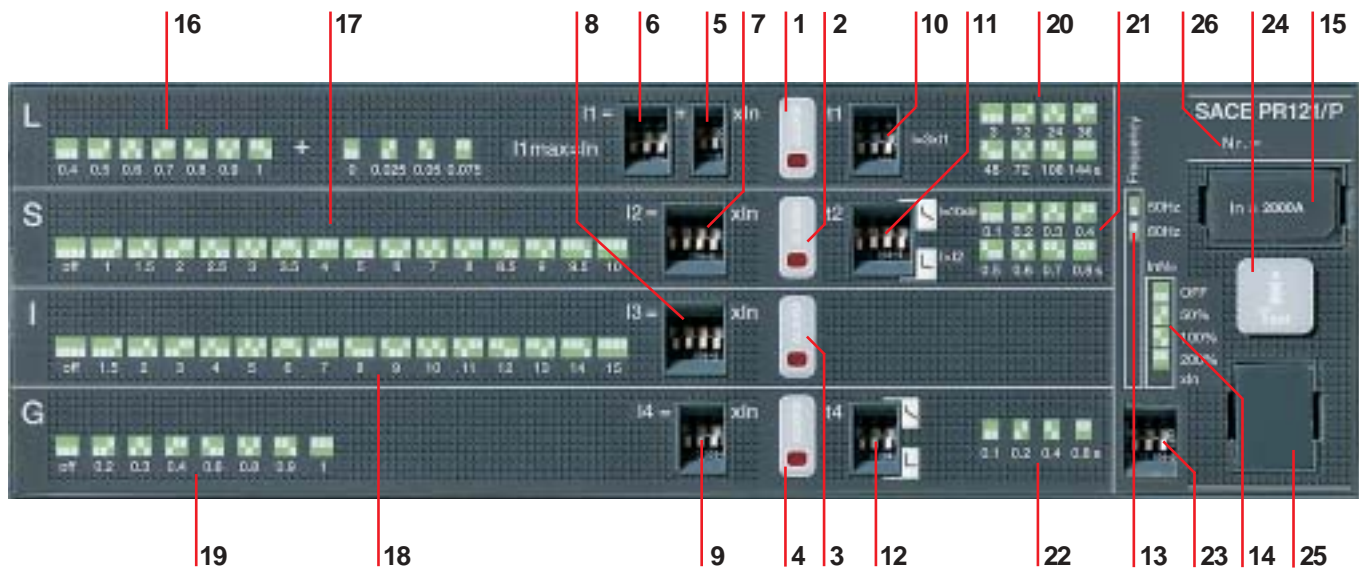

#### Caption

- |  |  |   |   |
|--|--|---|---|
| <ul style="list-style-type: none"> <li>1 LED signaling Alarm for protection function L</li> <li>2 LED signaling Alarm for protection function S</li> <li>3 LED signaling Alarm for protection function I</li> <li>4 LED signaling Alarm for protection function G</li> <li>5 DIP switches for fine setting current threshold I1</li> <li>6 DIP switches for main setting current threshold I1</li> <li>7 DIP switches for setting current threshold I2</li> <li>8 DIP switches for setting current threshold I3</li> </ul> | <ul style="list-style-type: none"> <li>9 DIP switches for setting current threshold I4</li> <li>10 DIP switches for setting trip time t1 (type of curve)</li> <li>11 DIP switches for setting trip time t2 (type of curve)</li> <li>12 DIP switches for setting trip time t4 (type of curve)</li> <li>13 Indication of the DIP switch position for network frequency</li> <li>14 Indication of the DIP switch position for Neutral protection setting</li> <li>15 Rating plug</li> <li>16 Indication of the DIP switch positions for the various current thresholds values I1</li> </ul> | <ul style="list-style-type: none"> <li>17 Indication of the DIP switch positions for the various current threshold values I2</li> <li>18 Indication of the DIP switch positions for the various current threshold values I3</li> <li>19 Indication of the DIP switch positions for the various current threshold values I4</li> <li>20 Indication of DIP switch positions for the various time settings t1</li> <li>21 Indication of DIP switch positions for the various time settings t2</li> <li>22 Indication of DIP switch positions for the various time settings t4</li> <li>23 DIP switch for setting network frequency and neutral protection setting</li> </ul> | <ul style="list-style-type: none"> <li>24 Trip cause indication and trip test pushbutton</li> <li>25 Test connector for connecting or testing the trip unit through an external device (PR030/B battery unit, BT030 wireless communication unit and PR10/T unit)</li> <li>26 Serial number of protection trip unit</li> </ul> |
|--|--|---|---|

1SD200109000

## Operation and protection functions

### Protection functions

The PR121 trip unit offers the following protection functions:

- overload (L)
- selective short circuit (S)
- instantaneous short circuit (I)
- ground fault (G).

### Overload (L)

The long time-delay trip protection L is type  $I^2t = k$ ; 25 current thresholds and 8 curves are available. Each curve is identified by the trip time in relation to the current  $I = 3 \times I_1$  ( $I_1 =$  set threshold).

### Selective short circuit (S)

The selective short circuit protection S can be set with two different types of curves with a trip time independent of the current ( $t = k$ ) or with a con-

stant specific let-through energy ( $t = k/I^2$ ).

15 current thresholds and 8 curves are available, allowing a fine setting. Each curve is identified as follows:

– for curves  $t = k$  by the trip time for  $I > I_2$

– for curves  $t = k/I^2$  by the trip time for  $I = 10 \times I_n$  ( $I_n =$  rated current of the circuit breaker).

The function can be excluded by setting the DIP switch combination to "OFF".

### Adjustable instantaneous short circuit (I)

The protection I offers 15 trip thresholds and can be excluded (dip switches in "OFF" position).

### Ground fault (G)

The ground fault protection G (which can be excluded) offers 7 current thresholds and 4 curves. Each curve is identified by the time  $t_4$  in relation to current  $I_4$ . As per S protection the trip time can be chosen independent of the current ( $t = k$ ) or with a constant specific let-through energy ( $t = k/I^2$ ).

Note: the maximum value for the function G is 1200 A and this function is repressed for fault current values higher than the values shown in table below.

I4 threshold	Repression threshold
$I_4 < 0.5 I_n$	$4 I_n$
$0.5 I_n \leq I_4 < 0.8 I_n$	$6 I_n$
$I_4 \geq 0.8 I_n$	$8 I_n$

$I_n =$  rated current of the rating plug

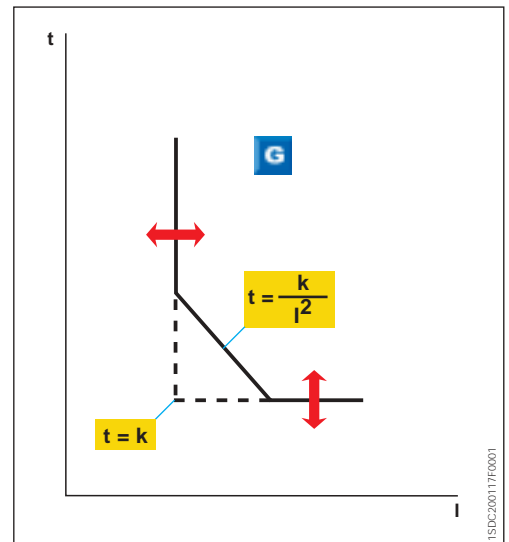
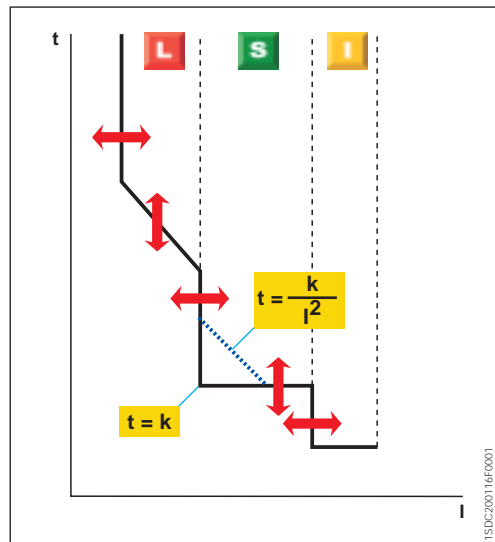



# Trip units and trip curves

## PR121/P

### User interface

The trip unit can be set by using the dip switches on the front.

Up to four LEDs (according to the version) are also available for signalling.

These LEDs (one for each protection) are active when:

- a protection is timing. For protection L the prealarm status is also shown;
- a protection has tripped (the corresponding LED is activated by pressing the "Info/Test" pushbutton);
- a failure in connection of a current sensor or in the opening solenoid is detected. The indication is active when the unit is powered (through current sensors or an auxiliary power supply)
- wrong rating plug for the circuit breaker.

The protection tripped indication works even with the circuit breaker open, without the need for any internal or external auxiliary power supply. This information is available for 48 hours of inactivity after the trip and is still available after reclosing. If the query is made more than 48 hours later it is sufficient to connect a PR030/B battery unit, PR010/T, or a BT030 wireless communication unit.

### Communication

By means of the BT030 wireless communication unit, PR121/P can be connected to a pocket PC (PDA) or to a personal computer, extending the range of information available for the user. In fact, by means of ABB's SD-Pocket communication software, it is possible to read the values of the currents flowing through the circuit breaker, the value of the last 20 interrupted currents, and the protection settings.

PR121 can also be connected to the optional external PR021/K signaling unit, for the remote signaling of protections alarms and trips, and to HMI030, for the remote user interfacing.

### Setting the neutral

Protection of the neutral can be set at 50%, 100% or 200% of the phase currents. Settings above 50% can be selected for E1-E2-E3-E4/f and E6/f. In particular, setting the neutral at 200% of phase current requires protection L to be set at  $0.5I_n$  in order to respect the current-carrying capacity of the circuit breaker. The user can also switch the neutral protection OFF. When three-poles circuit breakers with external neutral current sensor are used, a setting above 100% for the neutral does not require any reduction in the L setting.

### Test Function

A trip test can be carried out using the info/Test pushbutton and the PR030/B battery unit (or BT030).

The PR121/P electronic trip unit can be tested by using the PR010/T test and configuration unit by connecting it to the TEST connector.

All the trip unit functions can be exhaustively checked by means of the TS120 Test kit which allows physical injection of simulated current values to the trip unit and fully verifies its correct behaviour. To use this unit, the trip unit must be disconnected from the circuit breaker.

### Versions available

The following versions are available:



PR121/P LI

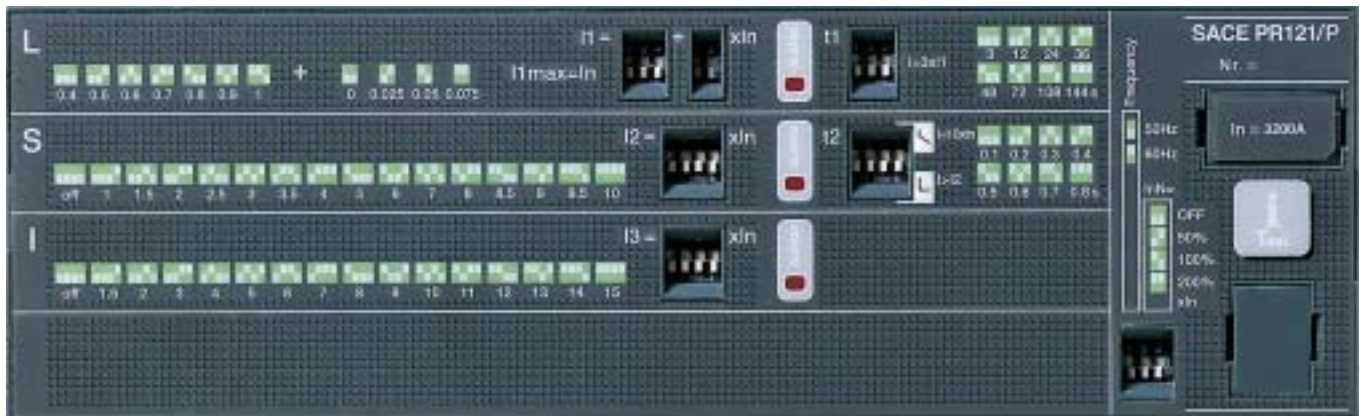

PR121/P LSI

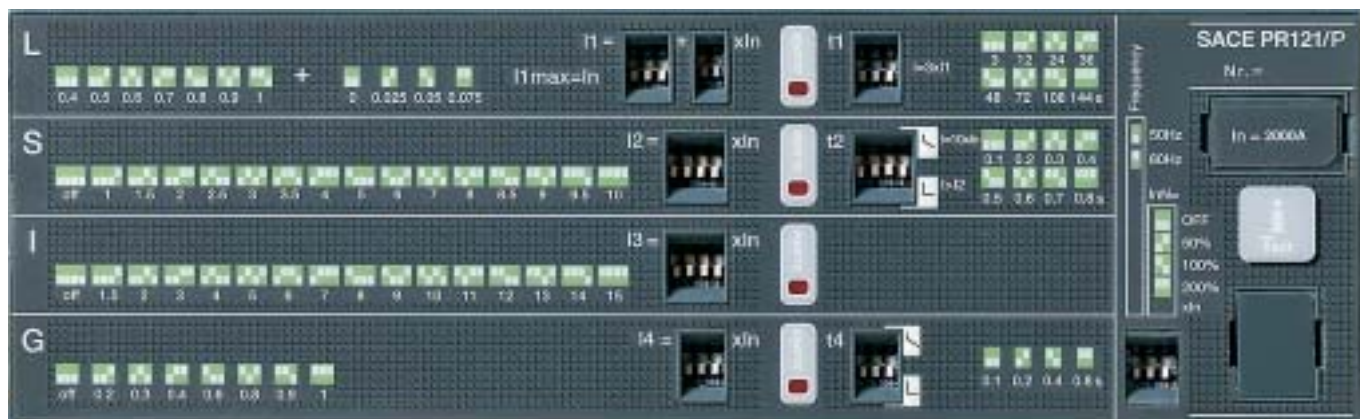

PR121/P LSIG



# Trip units and trip curves

## PR121/P

### Protection functions and setting values - PR121

Function	Trip threshold	Trip time	Can be excluded	Relation $t=f(I)$
<b>L</b> Overload protection	I1= 0.4 - 0.425 - 0.45 - 0.475 - 0.5 - 0.525 - 0.55 - 0.575 - 0.6 - 0.625 - 0.65 - 0.675 - 0.7 - 0.725 - 0.75 - 0.775 - 0.8 - 0.825 - 0.85 - 0.875 - 0.9 - 0.925 - 0.95 - 0.975 - 1 x In	At current $I = 3 \times I1$ t1 = 3 - 12 - 24 - 36 - 48 - 72 - 108 - 144 s <sup>(1)</sup>	–	$t=k/I^2$
Tolerance <sup>(2)</sup>	Release between 1.05 and 1.2 x I1	± 10% $I_{sc}^{(4)} \leq 4 \times I1$ ± 20% $I_{sc}^{(4)} > 4 \times I1$		
<b>S</b> Selective short-circuit protection	I2= 1 - 1.5 - 2 - 2.5 - 3 - 3.5 - 4 - 5 - 6 - 7 - 8 - 8.5 - 9 - 9.5 - 10 x In	At current $I > I2$ t2 = 0.1 - 0.2 - 0.3 - 0.4 - 0.5 - 0.6 - 0.7 - 0.8 s	■	$t=k$
Tolerance <sup>(2)</sup>	± 7% $I_{sc}^{(4)} \leq 4 \times I1$ ± 10% $I_{sc}^{(4)} > 4 \times I1$	The best of the given: ± 10% or ± 40 ms		
	I2= 1 - 1.5 - 2 - 2.5 - 3 - 3.5 - 4 - 5 - 6 - 7 - 8 - 8.5 - 9 - 9.5 - 10 x In	At current $I = 10 \times I1$ t2 = 0.1 - 0.2 - 0.3 - 0.4 - 0.5 - 0.6 - 0.7 - 0.8 s	■	$t=k/I^2$
Tolerance <sup>(2)</sup>	± 7% $I_{sc}^{(4)} \leq 4 \times I1$ ± 10% $I_{sc}^{(4)} > 4 \times I1$	± 15% $I_{sc}^{(4)} \leq 4 \times I1$ ± 20% $I_{sc}^{(4)} > 4 \times I1$		
<b>I</b> Instantaneous short-circuit protection	I3= 1.5 - 2 - 3 - 4 - 5 - 6 - 7 - 8 - 9 - 10 - 11 - 12 - 13 - 14 - 15 x In	Instantaneous	■	$t=k$
Tolerance <sup>(2)</sup>	± 10%	≤ 30 ms		
<b>G</b> Ground fault protection	I4= 0.2 - 0.3 - 0.4 - 0.6 - 0.8 - 0.9 - 1 x In <sup>(3)</sup>	At current $I = 4 \times I4$ t4 = 0.1 - 0.2 - 0.4 - 0.8 s	■	$t=k/I^2$
Tolerance <sup>(2)</sup>	± 7%	± 15%		
	I4= 0.2 - 0.3 - 0.4 - 0.6 - 0.8 - 0.9 - 1 x In <sup>(3)</sup>	At current $I > I4$ t4 = 0.1 - 0.2 - 0.4 - 0.8 s	■	$t=k$
Tolerance <sup>(2)</sup>	± 7%	The best of the given: ± 10% or ± 40 ms		

(1) The minimum trip time is 1 s, regardless of the type of curve set (self-protection)

(2) These tolerances are valid with the following hypotheses:

- trip unit self supplied when running (without start-up)
- two-phase or three-phase power supply
- trip time set ≥ 100 ms

(3) The maximum value for G protection is 1200 A

(4) Short circuit current

In all cases not covered by the above hypotheses, the following tolerance values are valid:

Trip threshold	Trip time
L Release between 1.05 and 1.25 x I1	± 20%
S ± 10%	± 20%
I ± 15%	≤ 60ms
G ± 15%	± 20%

### Power supply

The unit does not require an external power supply either for protection functions or for alarm signaling functions. It is self-supplied by means of the current sensors installed on the circuit breaker. For it to operate, it is sufficient for at least one phase to be loaded at 100A of the rated current of the current sensors (In). An external power supply can be connected in order to activate additional features, and in particular for connection to external devices: HMI030, and PR021/K.

PR121/P	
Auxiliary power supply (galvanically insulated)	24 V DC ± 20%
Maximum ripple	5%
Inrush current @ 24V	~10 A for 5 ms
Rated power @ 24V	~2 W



### Functions L-I

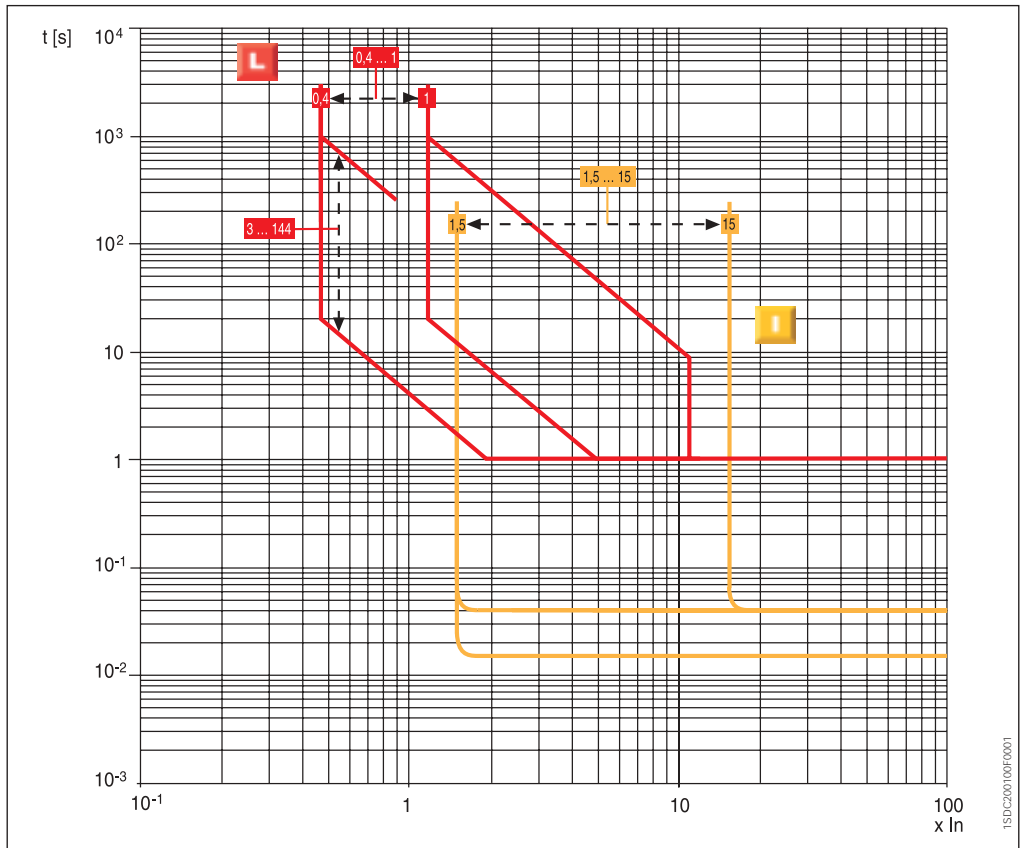

1SD0C200100F0001

### Functions L-S-I

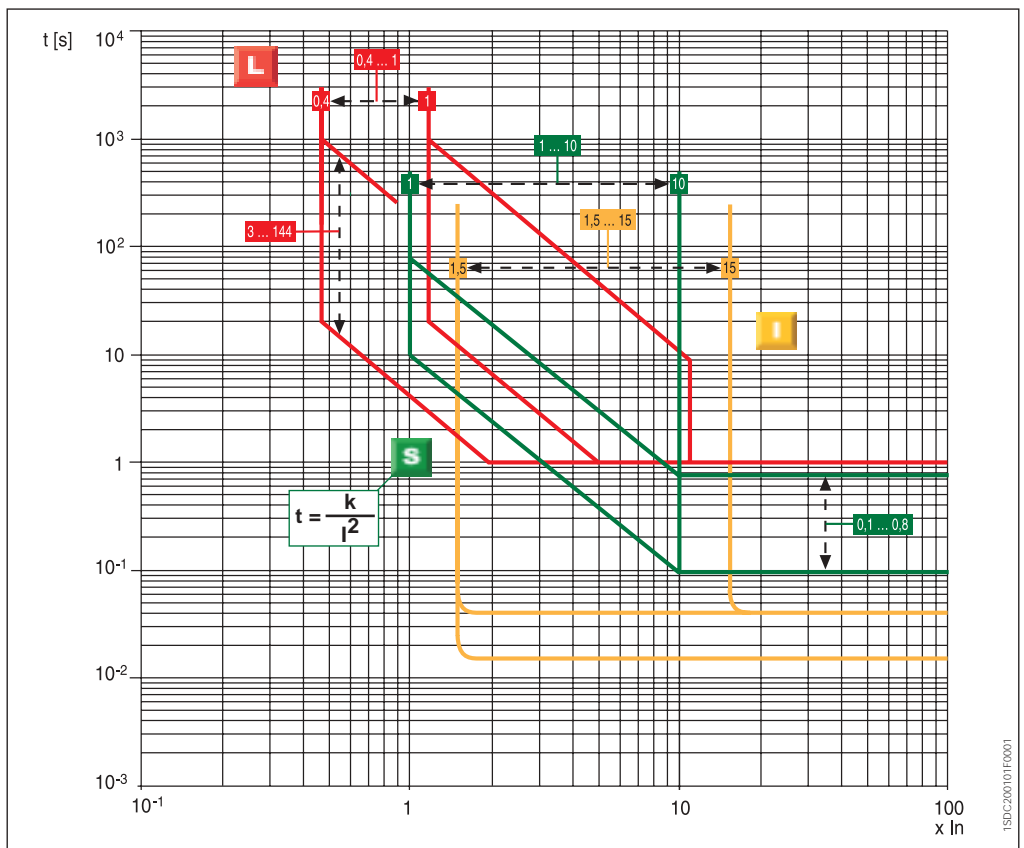

1SD0C200101F0001

Threshold and trip times tolerances ..... page 3/6



# Trip units and trip curves

## PR121/P

### Functions L-S-I

3

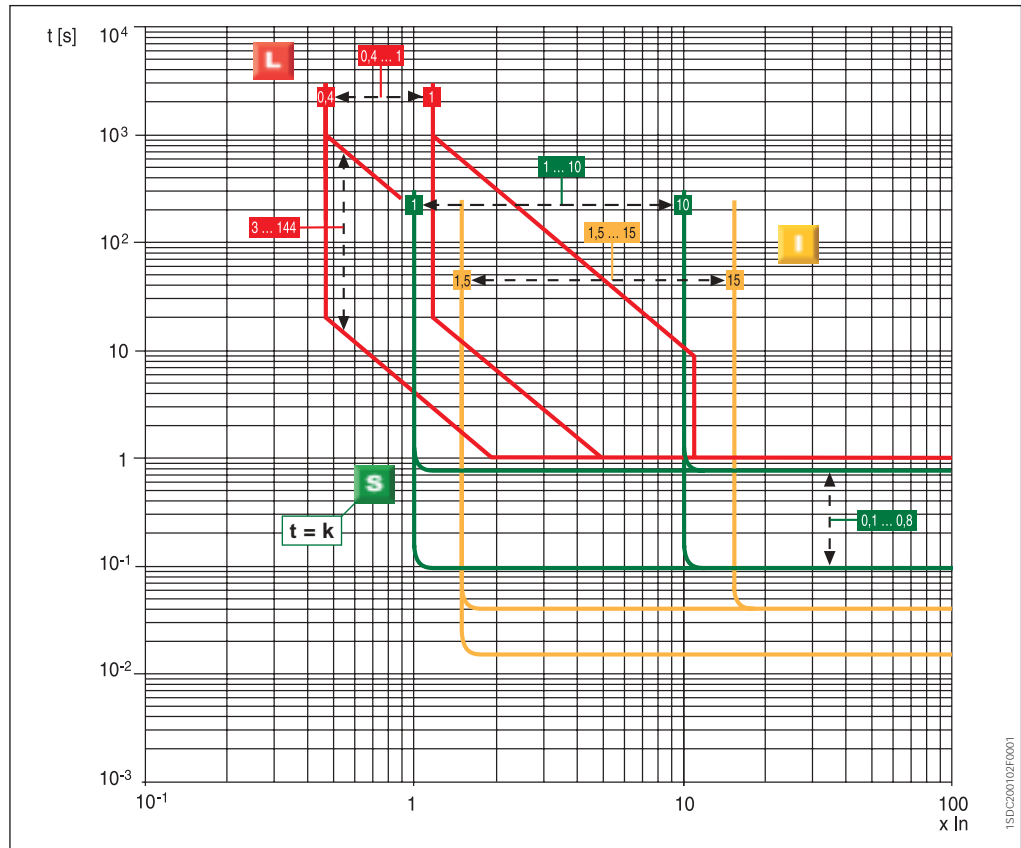

### Function G

**Note:** The maximum value for G protection is 1200 A

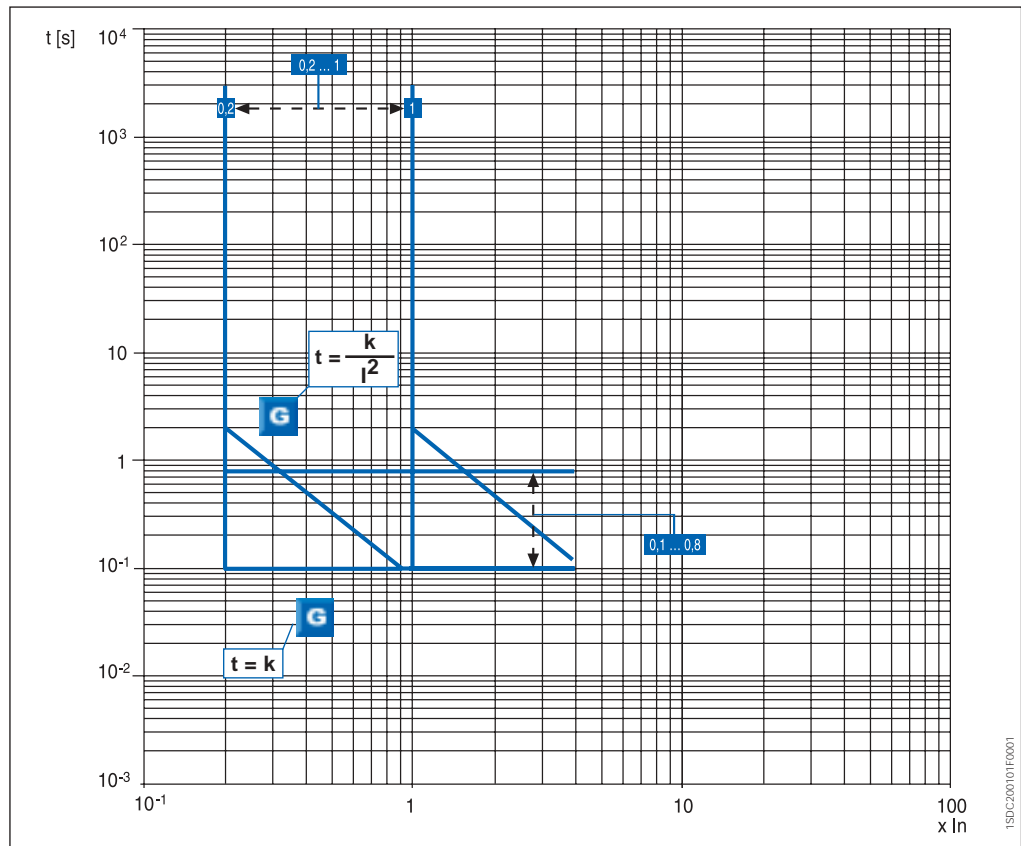

Threshold and trip times tolerances ..... page 3/6



# Trip units and trip curves

## PR122/P

### Characteristics

The PR122 trip unit is an advanced and flexible protection system based on a state-of-the-art microprocessor and DSP technology. Fitted with the optional internal PR120/D-M dialogue unit, PR122/P turns into an intelligent protection, measurement and communication device, based on the Modbus® protocol. By means of the PR120/D-M, PR122/P can also be connected to the ABB EP010 Fieldbus plug adapter, which makes it possible to choose among several different networks, such as Profibus and DeviceNet (IEC only).

The new PR122/P is the result of ABB's experience in designing trip units. The exhaustive range of settings makes this trip unit ideal for general use in any type of installation, from distribution to the protection of motors, transformers, drives and generators. Access to information and programming using a keyboard and graphic liquid crystal display is extremely simple and intuitive. The interface is now common to PR122/P and PR123/P in order to give to the user maximum ease of use.

An integrated ammeter and many other additional features are provided over and above the protection functions. These additional functions can be further increased with addition on board of the dialogue, signaling, measurement, and wireless communication units.

Functions S and G can operate with a time delay independent of the current ( $t = k$ ) or with an inverse time delay (constant specific let-through energy:  $I^2t = k$ ), as required. Protection against ground faults can also be obtained by connecting the PR122 trip unit to an external toroid located on the conductor that connects the transformer star centre to ground (homopolar toroid).

All the thresholds and trip curve delays of the protection functions are stored in special memories which retain the information even when no power is supplied.

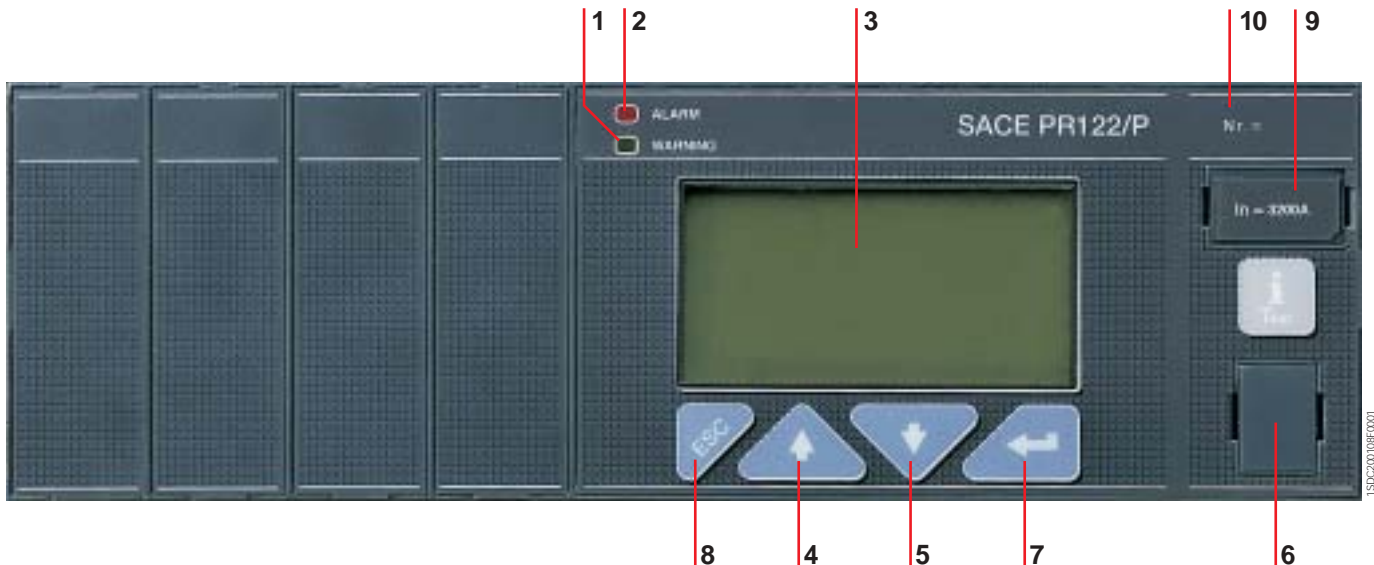

#### Caption

- |                            |  |  |
|----------------------------|--|--|
| 1 LED Warning indicator    | 6 Test connector for connecting or testing the trip unit by means of an external device (PR030/B battery unit, BT030 wireless communication unit and PR010/T unit) | 8 Button to exit submenus or cancel operations (ESC) |
| 2 Alarm LED                | 7 ENTER button to confirm data or change pages   | 9 Rating plug  |
| 3 Rear-lit graphic display |  | 10 Serial number of protection trip unit             |
| 4 Cursor UP button         |  |  |
| 5 Cursor DOWN button       |  |  |



# Trip units and trip curves

## PR122/P

3

### Operation, protection functions and self-test

#### Basic Protection functions

The PR122 trip unit offers the following protection functions (according to the version):

- overload (L)
- selective short circuit (S)
- instantaneous short circuit (I)
- ground fault (G)
- phase unbalance (U)
- self-protection against over-temperature (OT)
- thermal memory for functions L and S
- zone discrimination for functions S and G
- residual current (Rc) with external toroid
- source ground return with external toroid

tion. The neutral protection can be excluded or set to 100% for E1, E2, E3, E4/f and E6/f. In installations where very high harmonics occur, the resulting current at the neutral can be higher than that of the phases. Therefore it is possible to set the neutral protection at 150% or 200% of the value set for the phases. In this case it is necessary to reduce the setting of protection L accordingly <sup>(1)</sup>.

The table below lists the neutral settings for the various possible combinations between type of circuit breaker and the threshold I1 setting.

avoids untimely tripping caused by the high inrush currents of certain loads (motors, transformers, lamps).

The start-up phase lasts from 100 ms to 1.5 s, in steps of 0.05 s. It is automatically recognized by the PR122 trip unit as follows:

- when the circuit breaker closes with the trip unit self-supplied;
- when the peak value of the maximum current exceeds  $0.1 \times I_n$ . A new start-up becomes possible after the current has fallen below the threshold of  $0.1 \times I_n$ , if the trip unit is supplied from an external source.

#### Setting the neutral

In PR122/P, and PR123/P as well, the neutral protection is 50% of the value set for phase protection in the standard ver-

#### Start-up function

The start-up function allows protections S, I and G to operate with higher trip thresholds during the start-up phase. This

**Note:**

(1) When three-pole circuit breakers with external neutral current sensor are used, a setting above 100% for the neutral does not require any reduction in the L setting up to  $I_n$ .

Circuit breaker model	Adjustable neutral protection settings		
	Threshold I1 settings (overload protection)		
	$0.4 \leq I1 \leq 0.5$	$0.5 < I1 \leq 0.66$	$0.66 < I1 \leq 1(*)$
E1B-N	0-50-100-150-200%	0-50-100-150%	0-50-100%
E2B-N-S-L	0-50-100-150-200%	0-50-100-150%	0-50-100%
E3N-S-H-V-L	0-50-100-150-200%	0-50-100-150%	0-50-100%
E4S-H-V-L	0-50-100%	0-50%	0-50%
E4S/f-H/f	0-50-100-150-200%	0-50-100-150%	0-50-100%
E6H-V-L	0-50-100%	0-50%	0-50%
E6H/f	0-50-100-150-200%	0-50-100-150%	0-50-100%

(\*) The setting  $I1 = 1$  indicates the maximum overload protection setting. The actual maximum setting allowable must take into account any derating based on temperature, the terminals used and the altitude (see the "Installations" chapter)

### Phase unbalance protection U

Protection function U against phase unbalance is used in those situations requiring particularly precise control over missing and/or unbalanced phase currents. This function can be excluded.

### Protection against over-temperature

The range of PR122 trip units allows the presence of abnormal temperatures, which could cause temporary or continuous malfunctions of the microprocessor, to be signalled to the user. The user has the following signals or commands available:

- lighting up of the "Warning" LED when the temperature is higher than 158 °F / 70 °C (temperature at which the microprocessor is still able to operate correctly)
- lighting up of the "Alarm" LED when the temperature is higher than 185 °F / 85 °C (temperature above which the microprocessor can no longer guarantee correct operation) and, when decided during the unit configuration stage, simultaneous opening of the circuit breaker with indication of the trip directly on the display, as for the other protections.

### Zone discrimination for protections S and G

Zone discrimination is one of the most advanced methods for making co-ordination of the protections: by using this protection philosophy, it is possible to reduce the trip times of the protection closest to the fault in relation to the times foreseen by time discrimination, of which zone discrimination is an evolution.

Zone discrimination is applicable to protection functions S and G, even contemporarily and is available as standard on the PR122.

The word "zone" is used to refer to the part of an installation between two circuit breakers in series (see picture beside). Protection is provided by connecting all of the zone discrimination outputs of the trip units belonging to the same zone together and taking this signal to the zone discrimination input of the trip unit immediately to the supply side.

Each circuit breaker that detects a fault communicates this to the circuit breaker on the supply side using a simple connection wire. Therefore the fault zone is the zone immediately to the load side of the circuit breaker that detects the fault, but does not receive any communication from those on the load side. This circuit breaker opens without waiting for the set time-delay.

ABB provides important calculation tools to facilitate the work of designers in coordinating protection devices, including the Slide rule kits, DOCWin and CAT software packages and updated coordination charts.

The zone discrimination function S and G can be activated or deactivated using the keyboard.

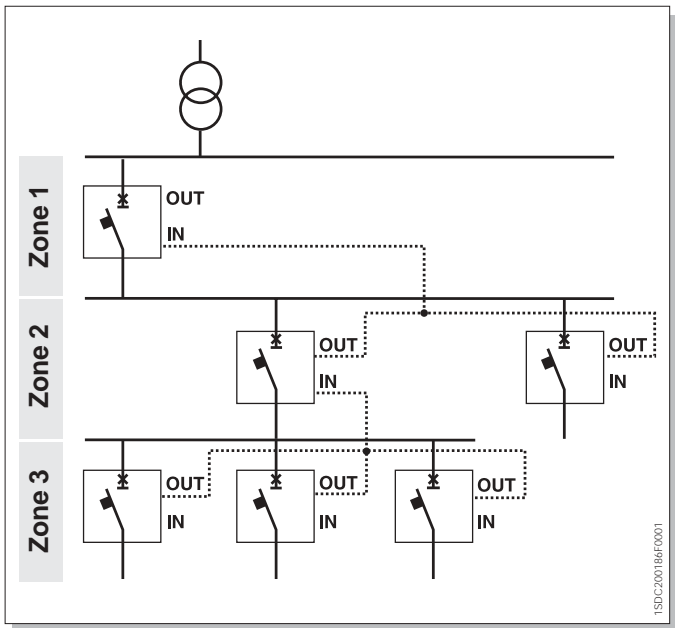



## Trip units and trip curves

### PR122/P

#### Phase unbalance U

Function U against phase unbalance simply emits a warning signal if an unbalance is detected between two or more phases. This function can be disabled.

#### Self-diagnosis

The PR122 range of trip units contains an electronic circuit which periodically checks the continuity of internal connections (opening solenoid or each current sensor, including the Source Ground Return when present).

In the case of a malfunction an alarm message appears directly on the display. The alarm is highlighted by the alarm LED as well.

#### Residual Current

Different solutions are available for integrated residual current protection. The basic choice is PR122/P-LSIRc, which has all the characteristics of PR122/P-LSI and residual current protection as well. When additional features are required, the solution is PR122/P LSIG with an additional PR120/V module (see next paragraph). Using this configuration, residual current protection is added to a powerful unit, having the features of PR122/P-LSI and all the add-ons described for the PR120/V module, such as voltage protection and advanced measurement functions.

Residual current protection acts by measuring the current from the external dedicated toroid.

#### Test Functions

Once enabled from the menu, the “info/Test” pushbutton on the front of the trip unit allows correct operation of the chain consisting of the microprocessor, opening solenoid and circuit breaker tripping mechanism to be checked.

The control menu also includes the option of testing correct operation of the display, signaling LEDs, and electrical contacts of the PR120/K trip unit.

By means of the front multi-pin connector it is possible to apply a PR010/T Test unit which allows the functions of the PR121, PR122 and PR123 ranges of trip units to be tested and checked.

All the trip unit functions can be exhaustively checked by means of the PR120/T Test kit which allows physical injection of simulated current values to the trip unit and fully verifies its correct behaviour. To use this unit, the trip unit must be disconnected from the circuit breaker.

#### User interface

The human-machine interface (HMI) of the device is made up of a wide graphic display, LEDs, and browsing pushbuttons. The interface is designed to provide maximum simplicity.

The language can be selected from among five available options: English, Italian, German, French and Spanish.

As in the previous generation of trip units, a password system is used to manage the “Read” or “Edit” modes. The default password, 0001, can be modified by the user.

The protection parameters (curves and trip thresholds) can be set directly via the HMI of the device. The parameters can only be changed when the trip unit is operating in “Edit” mode, but the information available and the parameter settings can be checked at any time in “Read” mode.

When a communication device (internal PR120/D-M and PR120/D-BT modules or external BT030 device) is connected, it is possible to set parameters simply by downloading them into the unit (by using the SD-Pocket software and a PDA or a notebook for PR120/D-BT and BT030). Parameterisation can then be carried out quickly and automatically in an error-free way by transferring data directly from DocWin.

#### Indicator LEDs

LEDs on the front panel of the trip unit are used to indicate all the pre-alarms (“WARNING”) and alarms (“ALARM”). A message on the display always explicitly indicates the type of event concerned.

Example of events indicated by the "WARNING" LED:

- unbalance between phases;
- pre-alarm for overload ( $L1 > 90\%$ );
- first temperature threshold exceeded ( $158\text{ °F} / 70\text{ °C}$ );
- contact wear beyond 80%;
- phase rotation reversed (with optional PR120/V)

Example of events indicated by the "ALARM" LED:

- overload (may begin from  $1.05 \times I_1 < I < 1.3 \times I_1$ , in accordance with the standard IEC 60947-2);
- timing of function L;
- timing of function S;
- timing of function G;
- second temperature threshold exceeded ( $185\text{ °F} / 85\text{ °C}$ );
- contact wear 100%;
- timing of Reverse Power flow protection (with optional PR120/V);

### Data logger

By default PR122/P, as well as PR123, is provided with the Data Logger function, that automatically records in a wide memory buffer the instantaneous values of all the currents and voltages. Data can be easily downloaded from the unit by means of SD-Pocket or TestBus2 applications using a Bluetooth port and can be transferred to any personal computer for elaboration. The function freezes the recording whenever a trip occurs, so that a detailed analysis of faults can be easily performed. SD-Pocket and TestBus2 allow also reading and downloading of all the others trip information.

- Number of channels: 8
- Maximum sampling rate: 4800 Hz
- Maximum sampling time: 27 s (@ sampling rate 600 Hz)
- 64 events tracking

### Trip information and opening data

In case a trip occurs PR122/P and PR123/P store all the needed information:

- Protection tripped
- Opening data (current)
- Time stamp (guaranteed with auxiliary supply or self-supply with power failure no longer than 48h)

By pushing the "info/Test" pushbutton the trip unit shows all these data directly on display.

No auxiliary power supply is needed. The information is available to user for 48 hours with the circuit breaker open or without current flowing.

The information of the latest 20 trips are stored in memory.

If the information can be furthermore retrieved more than 48 hours later, it is sufficient to connect a PR030/B battery unit or a BT030 wireless communication unit.

### Load control

Load control makes it possible to engage/disengage individual loads on the load side before the overload protection L is tripped, thereby avoiding unnecessary trips of the circuit breaker on the supply side. This is done by means of contactors or switches (externally wired to the trip unit), controlled by the PR122 by PR120/K internal contacts, or by PR021/K unit.

Two different Load Control schemes can be implemented:

- disconnection of two separate loads, with different current thresholds
- connection and disconnection of a load, with hysteresis

Current thresholds and trip times are smaller than those available for selection with protection L, so that load control can be used to prevent overload tripping.

Internal PR120/K or external PR021/K accessory unit is required for Load Control. The function is only active when an auxiliary power supply is present.



## Trip units and trip curves

### PR122/P

#### PR120/V Measurement Module

This optional internal module, installed in PR122 (standard in PR123), allows the trip unit to measure the phase and neutral voltages and to process them in order to achieve a series of features, in terms of protection and measurement.

PR120/V does not normally require any external connection or Voltage Transformer, since it is connected internally to the lower terminals of Emax. When necessary, the connection of voltage pick-ups can be moved to any other points (i.e. upper terminals), by using the alternative connection located in the terminal box. The module is provided with a sealable switch for the dielectric test. PR120/V is able to energize the PR122 while line voltage input is above 85V. The use of Voltage Transformers is mandatory for rated voltages higher than 690V.

Voltage transformers shall have burdens equal to 10VA and accuracy class 0.5 or better.



1SDC200114F0001

Additional Protections with PR120/V:

- Undervoltage (UV) protection
- Overvoltage (OV) protection
- Residual voltage (RV) protection
- Reverse power (RP) protection
- Underfrequency (UF) protection
- Overfrequency (OF) protection
- Phase sequence (alarm only)

All the above indicated protections can be excluded, although it is possible to leave only the alarm active when required.

With the circuit breaker closed, these protections also operate when the trip unit is self-supplied. With the circuit breaker open, they operate when the auxiliary power supply (24V DC or PR120/V) is present: in this case the trip unit will indicate the "ALARM" status.

#### Voltage protections UV, OV, RV

The residual voltage protection RV identifies interruptions of the neutral (or of the grounding conductor in systems with grounding neutral) and faults that shift the star centre in systems with insulated neutral (e.g. large ground faults). The star centre shift is calculated as a vectorial sum of the phase voltages.

#### Reverse power protection RP

Reverse power protection is especially suitable for protecting large machines such as motors and generators. The PR122 with the PR120/V module can analyse the direction of the active power and open the circuit breaker if the direction is opposite to that of normal operation. The reverse power threshold and the trip time are adjustable.

#### Frequency protections UF, OF

The frequency protections detect the variation of network frequency above adjustable thresholds, generating an alarm or opening the circuit breaker. It is a protection typically needed in an isolated network, i.e. powered by a genset.



### Measurement function

The current measurement function (ammeter) is present on all versions of the PR122 unit. The display shows histograms showing the currents of the three phases and neutral on the main page. Furthermore, the most loaded phase current is indicated in numerical format. Ground fault current, where applicable, is shown on a dedicated page.

The latter current value takes on two different meanings depending on whether the external toroidal transformer for the "Source Ground Return" function or the internal transformer (residual type) is connected.

The ammeter can operate either with self-supply or with an auxiliary power supply voltage. In the latter case the display is rear-lit and the ammeter is active even at current levels lower than 160A.

Accuracy of the ammeter measurement chain (current sensor plus ammeter) is no more than 1.5% in the 30% - 120% current interval of  $I_n$ .

- Currents: three phases (L1, L2, L3), neutral (Ne) and ground fault;
- Instantaneous values of currents during a period of time (data logger);
- Maintenance: number of operations, percentage of contact wear, opening data storage (last 20 trips and 20 events).

When the optional PR120/V is connected the following additional measurement function are present:

- Voltage: phase-phase, phase-neutral and residual voltage
- Instantaneous values of voltages during a period of time (data logger);
- Power: active, reactive and apparent
- Power factor
- Frequency and peak factor
- Energy: active, reactive, apparent, counter

### Versions available

The following versions are available:



1SDC200113F0001

PR122/P LI-LSI-LSIG-LSIRc



# Trip units and trip curves

## PR122/P

### Protection functions and setting values - PR122

Function	Trip threshold	Threshold steps	Trip Time	Time Step	Can be excluded	Relation t=f(I)	Thermal memory	Zone discrimination
<b>L</b> Overload protection Tolerance <sup>(2)</sup>	I1= 0.4...1 x In Release between 1.05 and 1.2 x I1	0.01 x In	At current I1= 3 x I1 t1= 3 s...144 s ± 10% I <sub>sc</sub> <sup>(5)</sup> ≤ 4 x In ± 20% I <sub>sc</sub> <sup>(5)</sup> > 4 x In	3 s <sup>(1)</sup>	–	t=k/I <sup>2</sup>	■	–
<b>S</b> Selective short circuit protection Tolerance <sup>(2)</sup>	I2= 0.6...10 x In ± 7% I <sub>sc</sub> <sup>(5)</sup> ≤ 4 x In ± 10% I <sub>sc</sub> <sup>(5)</sup> > 4 x In	0.1 x In	At current I > I2 t2= 0.05 s...0.8 s <sup>(2)</sup> The best of the two given: ± 10% or ± 40 ms	0.01 s	■	t=k	–	■
Tolerance <sup>(2)</sup>	I2= 0.6...10 x In ± 7% I <sub>sc</sub> <sup>(5)</sup> ≤ 4 x In ± 10% I <sub>sc</sub> <sup>(5)</sup> > 4 x In	0.1 x In	At current I= 10 x In t2= 0.05 s...0.85 s ± 15% I <sub>sc</sub> <sup>(5)</sup> ≤ 4 x In ± 20% I <sub>sc</sub> <sup>(5)</sup> > 4 x In	0.01 s	■	t=k/I <sup>2</sup>	■	–
<b>I</b> Instantaneous short circuit protection Tolerance <sup>(2)</sup>	I3= 1.5...15 x In ± 10%	0.1 x In	Instantaneous ≤ 30 ms	–	■	t=k	–	–
<b>G</b> Ground fault protection Tolerance <sup>(2)</sup>	I4= 0.2...1 x In <sup>(3)</sup> ± 7%	0.02 x In	At current I > I2 t4= 0.1 s...1 s The best of the two given: ± 10% or ± 40 ms	0.05 s	■	t=k	–	■
Tolerance <sup>(2)</sup>	I4= 0.2...1 x In <sup>(3)</sup> ± 7%	0.02 x In	t4= 0.1 s...1 s with I= 4 x I4 ± 15%	0.05 s	■	t=k/I <sup>2</sup>	–	■
<b>Rc</b> Residual Current protection Tolerance <sup>(2)</sup>	I <sub>d</sub> = 0.3-0.5-0.7-1-2-3-5-7-10-20-30 A ± 10%	–	t <sub>d</sub> = 0.06-0.1-0.2-0.3-0.4-0.5-0.8-1-3-4-4.8 s <sup>(3)</sup>	–	■	t=k	–	–
<b>OT</b> Protection against overtemperature	may not be set	–	Instantaneous	–	–	temp=k	–	–
<b>U</b> Phase unbalance protection Tolerance <sup>(2)</sup>	I <sub>6</sub> = 5%...90% ± 10%	5%	t <sub>4</sub> = 0.5 s...60 s The best of the two given: ± 20% or ± 100 ms	0.5 s	■	t=k	–	–

(1) The minimum trip value is 1 s, regardless of the type of curve set (self-protection)

(2) These tolerances are valid with the following hypotheses:

- relay self-supplied when running and/or auxiliary power supply (without start-up)
- two-phase or three-phase power supply
- trip time set ≥ 100 ms

(3) The maximum value for G protection is 1200 A

(4) Non intervention time

(5) Short circuit current

In all cases not covered by the above hypotheses, the following tolerance values are valid:

Trip threshold	Trip time
L Release between 1.05 and 1.25 x I1	± 20%
S ± 10%	± 20%
I ± 15%	≤ 60ms
G ± 15%	± 20%
Others	± 20%

## Additional Protection functions and setting values - PR122 with PR120/V

Function	Trip threshold	Threshold steps	Trip Time	Time Step	Can be excluded	Relation t=f(I)	Thermal memory	Zone discrimination
<b>UV</b> Undervoltage protection Tolerance <sup>(1)</sup>	$U8 = 0.5 \dots 0.95 \times U_n$ $\pm 5\%$	$0.01 \times I_n$	At current $U < U8$ $t8 = 0.1 \text{ s} \dots 5 \text{ s}$ The best of the two given: $\pm 20\%$ or $\pm 100 \text{ ms}$	0.1 s	■	t=k	–	■
<b>OV</b> Overvoltage protection Tolerance <sup>(1)</sup>	$U9 = 1.05 \dots 1.2 \times U_n$ $\pm 5\%$	$0.01 \times I_n$	At current $U > U9$ $t9 = 0.1 \text{ s} \dots 5 \text{ s}$ The best of the two given: $\pm 20\%$ or $\pm 100 \text{ ms}$	0.1 s	■	t=k	–	–
<b>RV</b> Residual voltage protection Tolerance <sup>(1)</sup>	$U10 = 0.1 \dots 0.4 \times U_n$ $\pm 5\%$	$0.05 \times U_n$	At current $U > U10$ $t10 = 0.5 \text{ s} \dots 30 \text{ s}$ The best of the two given: $\pm 10\%$ or $\pm 100 \text{ ms}$	0.5 s	■	t=k	–	–
<b>RP</b> Reverse power protection Tolerance <sup>(1)</sup>	$P11 = -0.3 \dots -0.1 \times P_n$ $\pm 5\%$	$0.02 \times P_n$	At current $P < P11$ $t11 = 0.5 \text{ s} \dots 25 \text{ s}$ The best of the two given: $\pm 10\%$ or $\pm 100 \text{ ms}$	0.1 s	■	t=k	–	–
<b>UF</b> Underfrequency protection Tolerance <sup>(1)</sup>	$f12 = 0.90 \dots 0.99 \times f_n$ $\pm 5\%$	$0.01 \times f_n$	At current $f < f12$ $t9 = 0.5 \text{ s} \dots 3 \text{ s}$ The best of the two given: $\pm 10\%$ or $\pm 100 \text{ ms}$	0.1 s	■	t=k	–	–
<b>OF</b> Overfrequency protection Tolerance <sup>(1)</sup>	$f13 = 1.01 \dots 1.10 \times f_n$ $\pm 5\%$	$0.01 \times f_n$	At current $f > f13$ $t10 = 0.5 \text{ s} \dots 3 \text{ s}$ The best of the two given: $\pm 10\%$ or $\pm 100 \text{ ms}$	0.1 s	■	t=k	–	–

(1) These tolerances are valid with the following hypotheses:

- relay self-supplied when running and/or auxiliary power supply (without start-up)
- two-phase or three-phase power supply

### Power supply

The PR122 trip unit does not normally require any external power supplies, being self-supplied from the current sensors (CS): to activate the protection and ammeter functions, it is sufficient for at least one phase to have a current load higher than 100 A of the rated current of the rating plug. For the display to come on, at least one phase must have a current load higher than 160 A of the rated current of the rating plug.

The unit ensures fully self-supplied operation. When an auxiliary power supply is present, it is also possible to use the unit with the circuit breaker either open or closed with very low current flowing through.

It is also possible to use an auxiliary power supply provided by the PR030/B portable battery unit (always supplied), which allows the protection functions to be set when the trip unit is not self-supplied.

PR122/P stores and shows all the information needed after a trip (protection tripped, trip current, time, date). No auxiliary supply is required for this functionality.

	PR122/P	PR120/D-M <sup>(*)</sup>	PR120/K	PR120/D-BT
Auxiliary power supply (galvanically insulated)	24 V DC $\pm 20\%$	from PR122/PR123	from PR122/PR123	from PR122/PR123
Maximum ripple	5%			
Inrush current @ 24V	$\sim 10 \text{ A}$ for 5 ms			
Rated power @ 24V	$\sim 3 \text{ W}$	+1 W	+1 W	+1 W

(\*) IEC only

#### Note:

PR120/V can give power supply to the trip unit when at least one line voltage is equal or higher to 85V RMS.



# Trip units and trip curves

## PR122/P

### Functions L-I

3

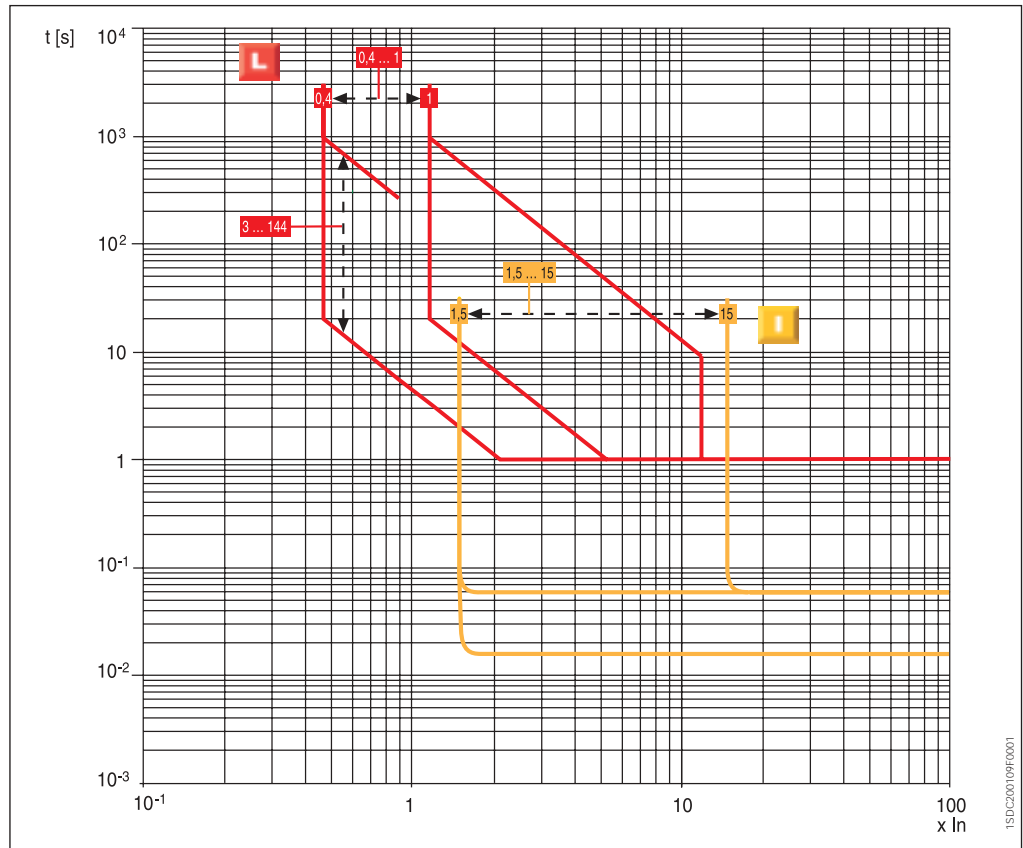

### Functions L-S-I

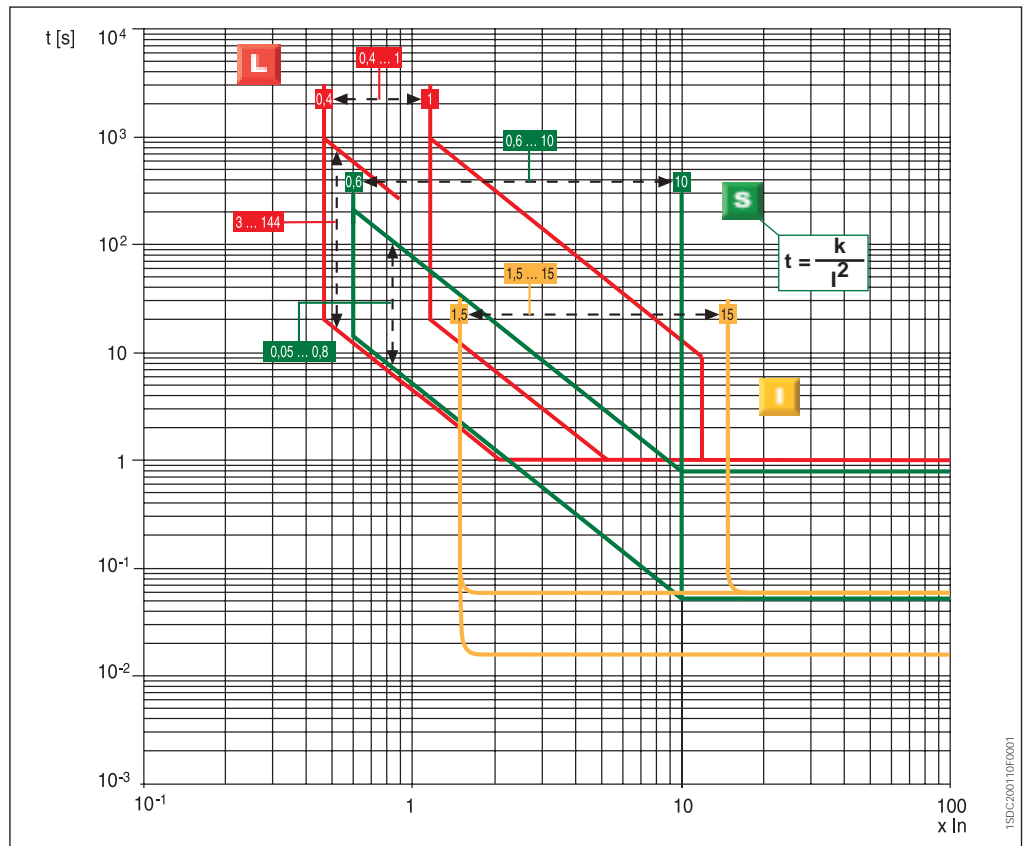

Threshold and trip times tolerances ..... page 3/16

## Functions L-S-I

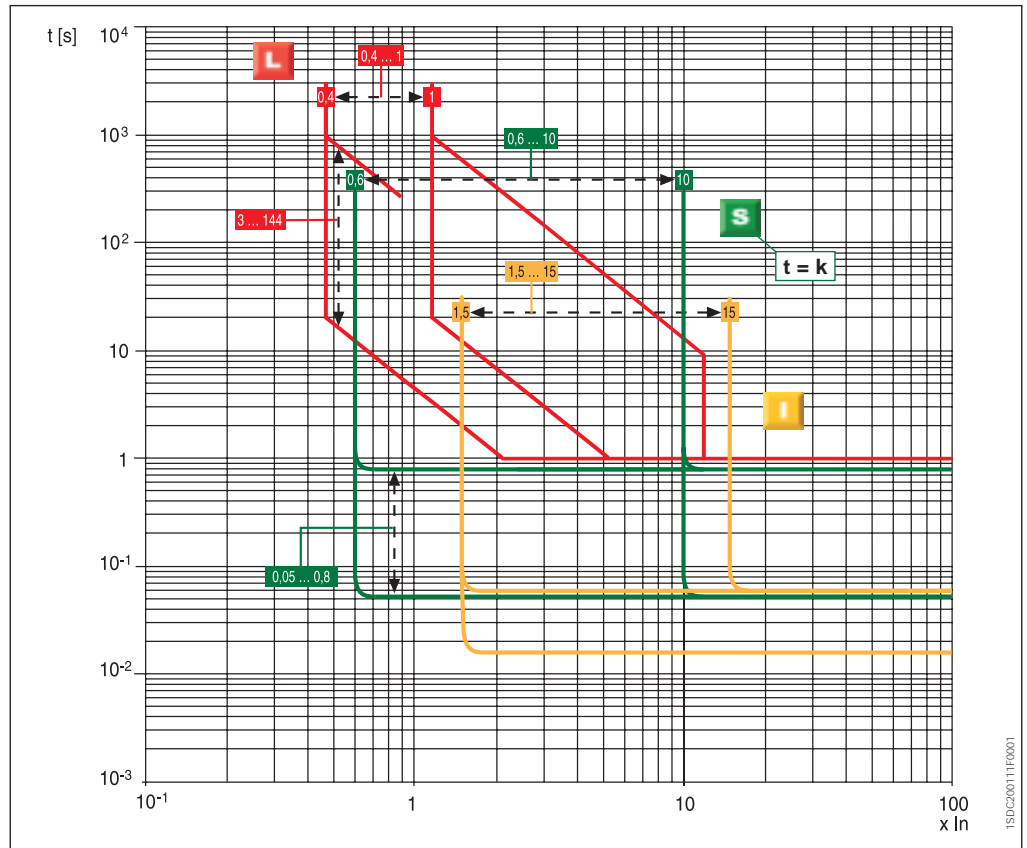

## Function G

**Note:** The maximum value for G protection is 1200 A

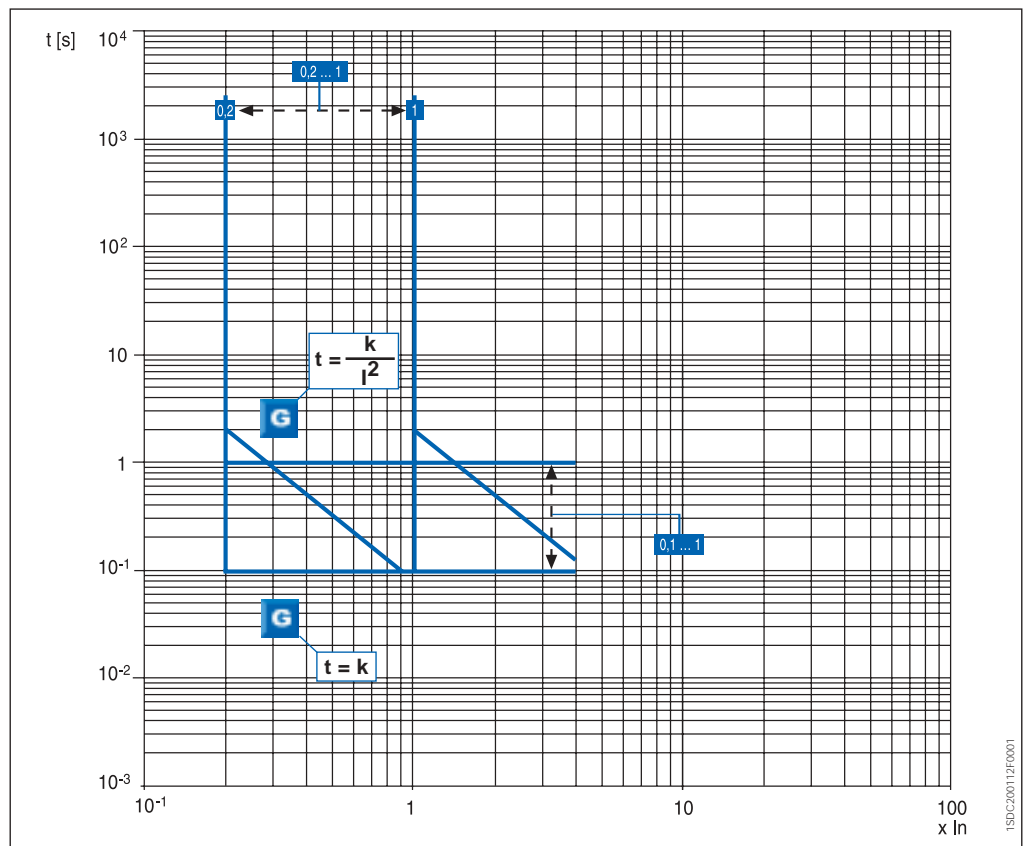

Threshold and trip times tolerances ..... page 3/16



# Trip units and trip curves

## PR122/P

### Function U

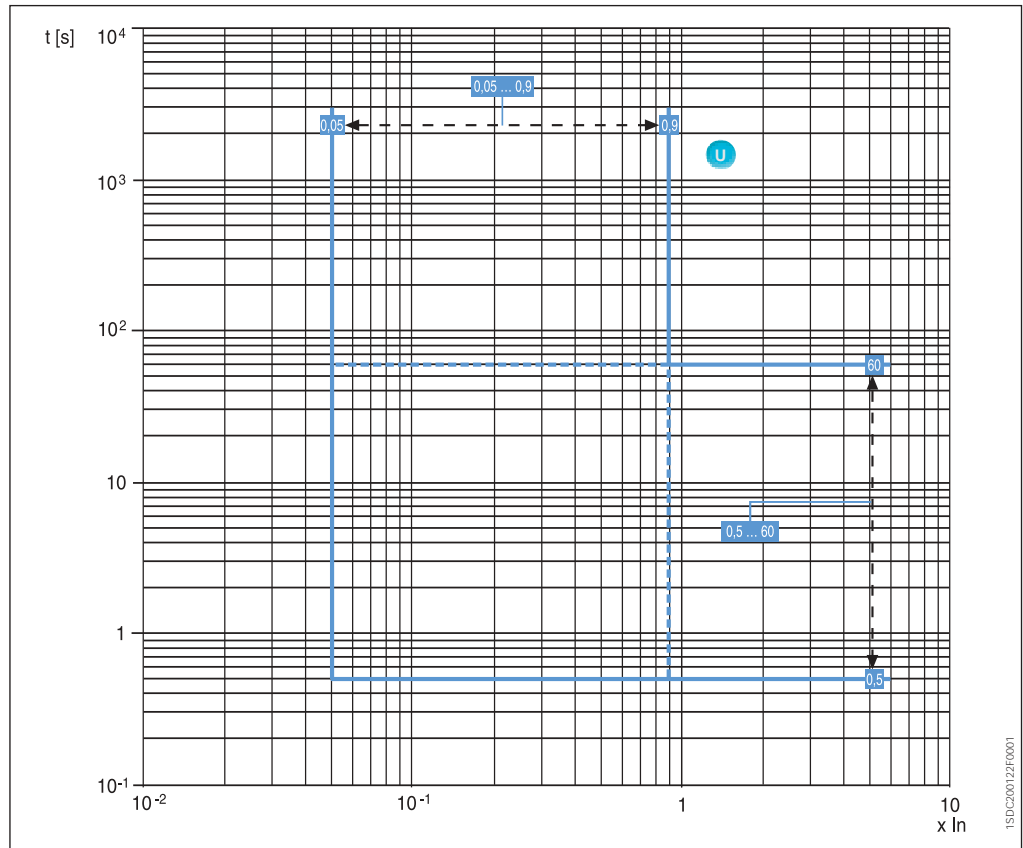

### Function UV

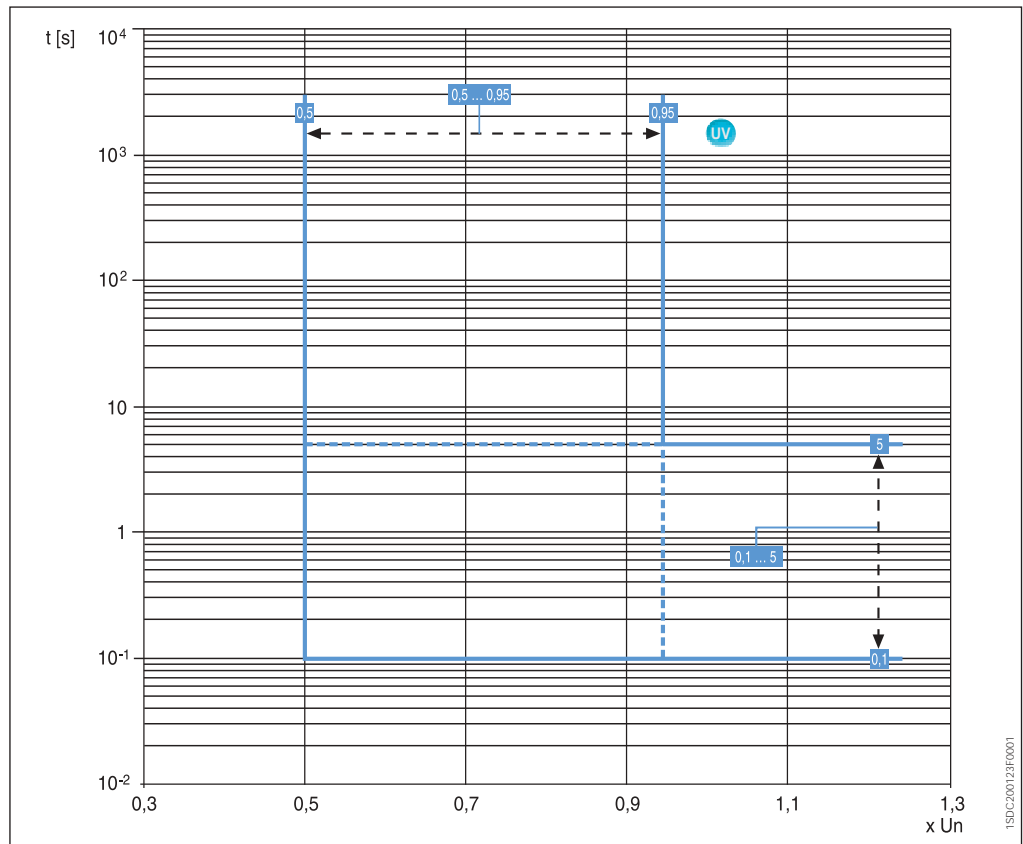

Threshold and trip times  
tolerances ..... page 3/16

### Function OV

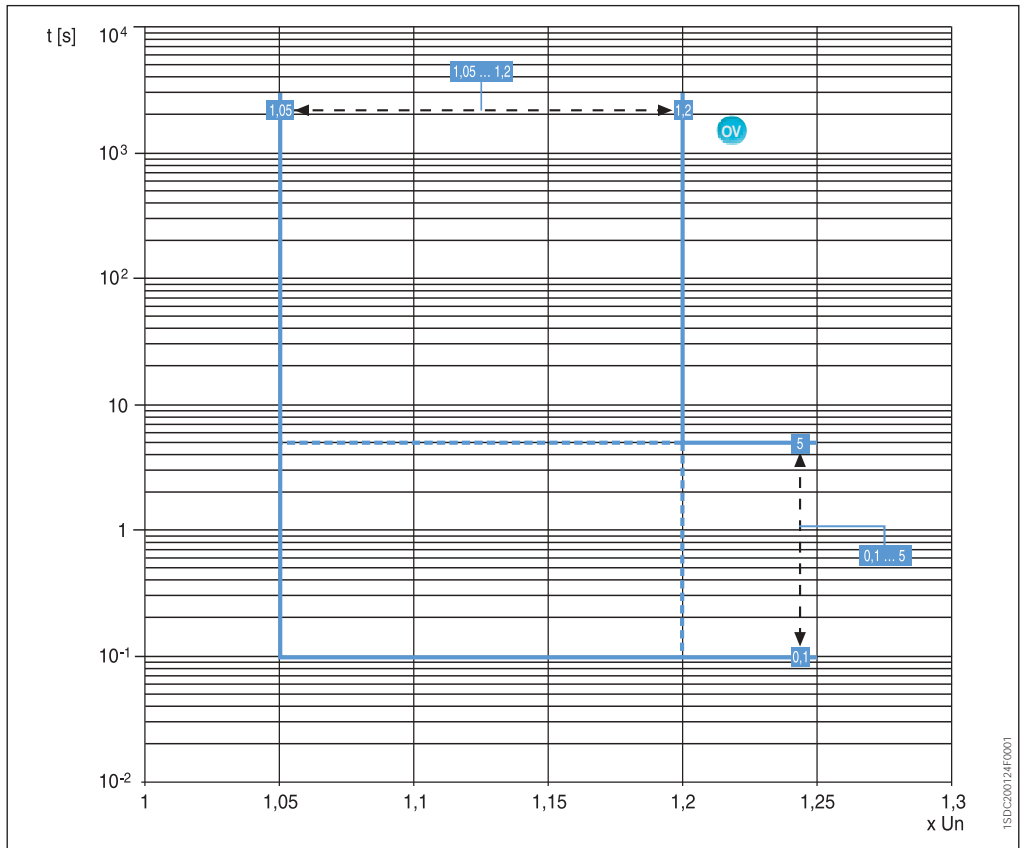

### Function RV

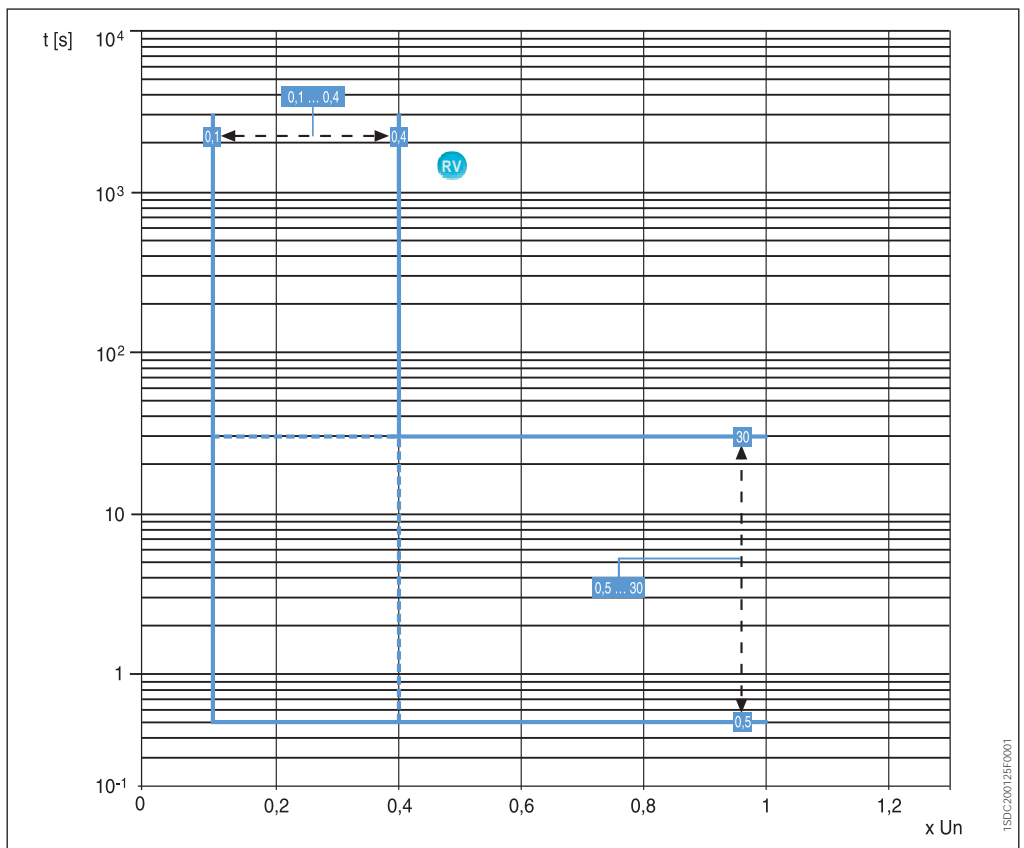

Threshold and trip times  
tolerances ..... page 3/16



# Trip units and trip curves

## PR122/P

### Function RP

3

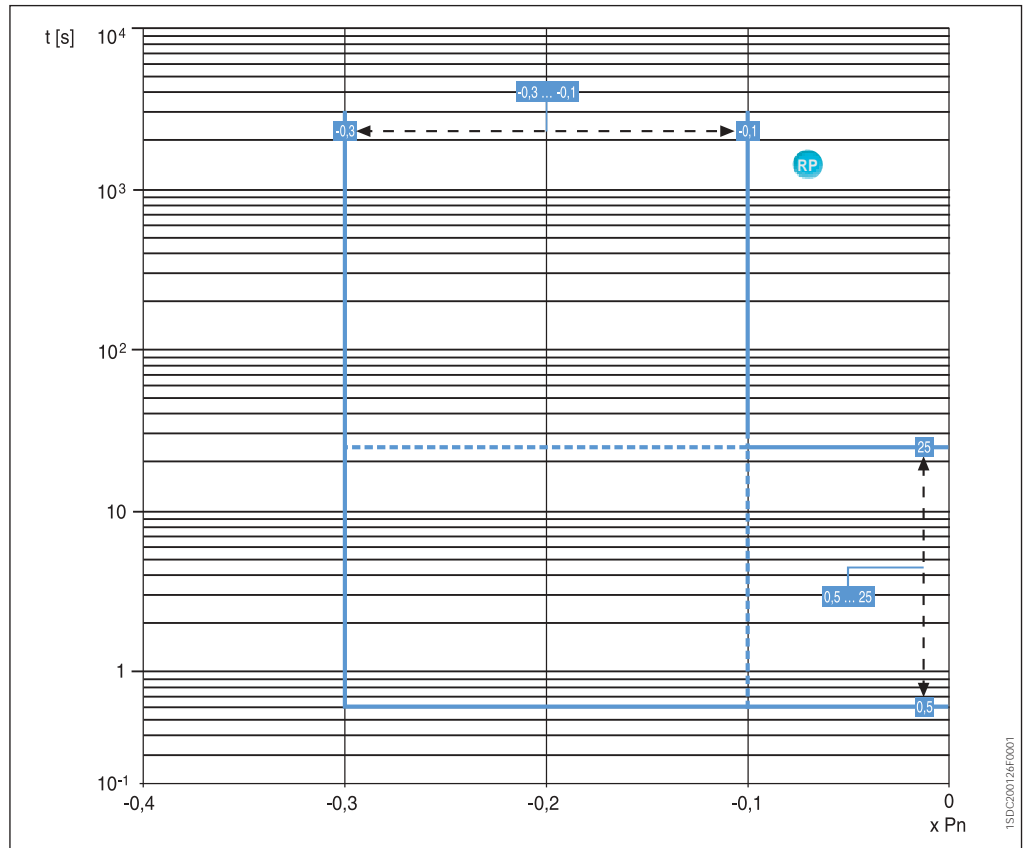





# Trip units and trip curves

## PR123/P

### Characteristics

The PR123 protection trip unit completes the range of trip units available for the Emax family of circuit breakers.

It is a high-performance and extraordinarily versatile trip unit, capable of offering a complete set of functions for protection, measurement, signalling, data storage and control of the circuit breaker, and it represents the benchmark in low voltage protection units for circuit breakers.

The front interface of the unit, common to PR122/P, is extremely simple thanks to the aid of the liquid crystal graphics display. It can show diagrams, bar graphs, measurements and sine curves for the various electrical values.

PR123 integrates all the features offered by PR122/P plus a series of evolute functionalities. As well as PR122 it can be integrated with the additional features provided by internal modules and external accessories.

3

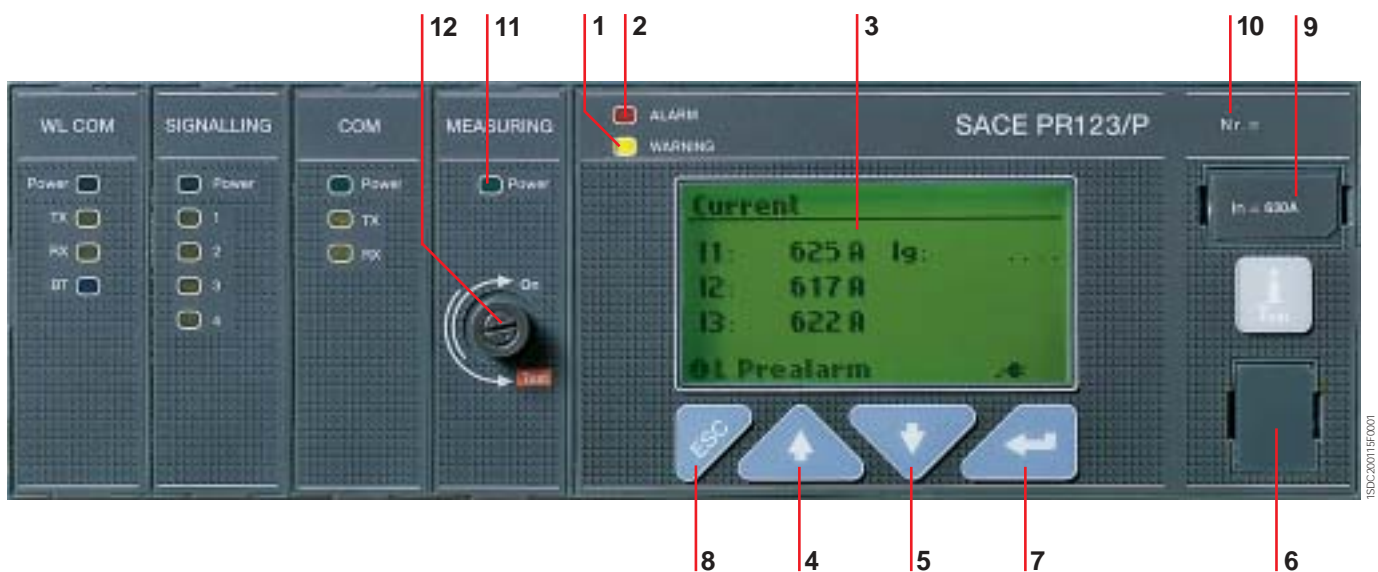

**Caption**

- |  |  |  |
|--|--|--|
| <ul style="list-style-type: none"> <li>1 LED Warning indicator</li> <li>2 Alarm LED</li> <li>3 Rear-lit graphic display</li> <li>4 Cursor UP button</li> <li>5 Cursor DOWN button</li> </ul> | <ul style="list-style-type: none"> <li>6 Test connector for connecting or testing the trip unit by means of an external device (PR030/B battery unit, BT030 wireless communication unit and PR010/T unit)</li> <li>7 ENTER button to confirm data or change pages</li> </ul> | <ul style="list-style-type: none"> <li>8 Button to exit submenus or cancel operations (ESC)</li> <li>9 Rating plug</li> <li>10 Serial number of protection trip unit</li> <li>11 Power LED</li> <li>12 Disconnector for voltage pickups</li> </ul> |
|--|--|--|



---

## Trip units and trip curves

### PR123/P

---

---

#### Protection functions

The PR123 trip unit offers the following protection functions:

- overload (L),
- selective short circuit (S),
- instantaneous short circuit (I),
- ground fault with adjustable delay (G),
- directional short circuit with adjustable delay (D),
- phase unbalance (U),
- protection against over-temperature (OT),
- load control (K),
- undervoltage (UV),
- overvoltage (OV),
- residual voltage (RV),
- reverse power (RP),
- underfrequency (UF),
- overfrequency (OF),
- phase sequence (alarm only).

In addition to PR122/P features, the following improvements are available:

#### Overload protection L

With the PR123 unit, the overload protection L includes the option to adjust the slope of the protection curve. This adjustment allows perfect coordination with fuses or with medium-voltage protection systems.

#### Double selective short-circuit protection S

In addition to the standard S protection, PR123/P makes contemporarily available a second time-constant S protection (excludible) that allows two thresholds to be set independently achieving an accurate discrimination even under highly critical conditions.

#### Double ground fault protection G

While in PR121/P and PR122/P the user must choose among the implementation of G protection through internal current sensors (calculating the vectorial sum of currents) or external toroid (direct ground fault current measuring), PR123/P offers the exclusive feature of the contemporaneous management of both the configuration, by means of two independent ground fault protections curves. The main application of this characteristic is simultaneous activation of restricted and unrestricted ground fault protection. See chapter 6 for details.

#### Directional short circuit protection with adjustable delay D

The protection works in a similar way to the fixed-time protection "S", with the added ability to recognize the direction of the phases current during the fault period.

With the information about the current direction it is possible to determine whether the fault is on the supply or load side of the circuit breaker. Particularly in ring distribution systems, with this protection you can disconnect just the portion of system where the fault has occurred, whilst keeping the rest of the installation running. If multiple PR122 or PR123 trip units are used, in the same system this protection can be associated with zone discrimination.

**Note:**

The directional short circuit protection can be disabled for an adjustable set time ( $t = k$ ), and can either be self-supplied or use the auxiliary power supply. Directional protection is not available on 400A rating.

**Dual setting of protections**

PR123/P can store an alternative set of all the protection parameters. This second set (set B) can replace, when needed, the default set (set A) by means of an external command. The command can be given typically when network configuration is modified, like when a parallel of incoming lines is closed or when an emergency source is present in the system, changing load capability and short circuit levels.

The set B can be activated by:

- digital input provided with PR120/K module. For example It can be connected to an auxiliary contact of a bus-tie
- communication network, through PR120/D-M (i.e. when the changeover is scheduled);
- directly from user interface of PR123/P
- an adjustable time interval after closing of the circuit breaker.

**Zone discrimination function**

The zone discrimination function allows the fault area to be insulated by opening the circuit breakers closest to the fault, whilst leaving the rest of the installation running.

This is done by connecting the trip units together: the trip unit nearest the fault is tripped instantly, sending a block signal to the other trip units affected by the same fault

The zone discrimination function can be enabled if the fixed-time curve has been selected and an auxiliary power supply is present.

Zone discrimination can be applied with protections S and G or, alternatively, with protection D.

**Measurement functions**

The PR123 trip unit provides a complete set of measurements:

- Currents: three phases (L1, L2, L3), neutral (Ne) and ground fault
- Voltage: phase-phase, phase-neutral and residual voltage
- Power: active, reactive and apparent
- Power factor
- Frequency and peak factor
- Energy: active, reactive, apparent, counter
- Harmonics calculation: up to the 40<sup>th</sup> harmonic (waveform and module of the harmonics displayed); up to the 35<sup>th</sup> for frequency  $f = 60\text{Hz}$
- Maintenance: number of operations, percentage of contact wear, opening data storage.

The PR123 unit is able to provide the pattern of measurements for some values over an adjustable period of time P, such as: mean active power, maximum active power, maximum current, maximum voltage and minimum voltage. The last 24 P periods (adjustable from 5 to 120 min.) are stored in a non-volatile memory and displayed in a bar graph.

**Other Functions**

PR123/P integrates all the features (in terms of protection, measurement, signaling and communication) described for PR122/P equipped with PR120/V.



# Trip units and trip curves

## PR123/P

### Protection functions and setting values - PR123

Function	Trip threshold	Threshold steps	Trip Time	Time Step	Can be excluded	Relation t=f(I)	Thermal memory	Zone discrimin.
<b>L</b> Overload protection	I1= 0.4...1 x In	0.01 x In	At current I= 3 x I1 <sup>(6)</sup> t1= 3 s...144 s	3 s <sup>(1)</sup>	–	t=k/I <sup>2</sup>	■	–
	Tolerance <sup>(2)</sup> Release between 1.05 and 1.2 x I1		± 10% I <sub>sc</sub> <sup>(5)</sup> ≤ 4 x In ± 20% I <sub>sc</sub> <sup>(5)</sup> > 4 x In					
Tolerance	I1= 0.4...1 x In	0.01 x In	At current I= 3 x I1 t1= 3 s...144 s	3 s	–			
	1.05 ... 1.2 x I1 (in accordance with IEC 60255-3)		± 20% I <sub>sc</sub> <sup>(5)</sup> > 5 x I1 ± 30% 2xI1 ≤ I <sub>sc</sub> <sup>(5)</sup> ≤ 5 x I1 In					
<b>S</b> Selective short circuit protection	I2= 0.6...10 x In	0.1 x In	At current I > I2 t2= 0.05 s...0.8 s	0.01s	■	t=k	–	■
	Tolerance <sup>(2)</sup> ± 7% I <sub>sc</sub> <sup>(5)</sup> ≤ 4 x In ± 10% I <sub>sc</sub> <sup>(5)</sup> > 4 x In		The best of the two given: ± 10% or ± 40 ms					
Tolerance <sup>(2)</sup>	I2= 0.6...10 x In	0.1 x In	At current I= 10 x In t2= 0.05 s...0.8 s	0.01s	■	t=k/I <sup>2</sup>	■	–
	± 7% I <sub>sc</sub> <sup>(5)</sup> ≤ 4 x In ± 10% I <sub>sc</sub> <sup>(5)</sup> > 4 x In		± 15% I <sub>sc</sub> <sup>(5)</sup> ≤ 4 x In ± 20% I <sub>sc</sub> <sup>(5)</sup> > 4 x In					
<b>S+</b> Selective short circuit protection	I2= 0.6...10 x In	0.1 x In	At current I > I2 t2= 0.05 s...0.8 s	0.01s	■	t=k	–	■
	Tolerance <sup>(2)</sup> ± 7% I <sub>sc</sub> <sup>(5)</sup> ≤ 4 x In ± 10% I <sub>sc</sub> <sup>(5)</sup> > 4 x In		The best of the two given: ± 10% or ± 40 ms					
Tolerance <sup>(2)</sup>	I2= 0.6...10 x In	0.1 x In	At current I= 10 x In t2= 0.05 s...0.8 s	0.01s	■	t=k/I <sup>2</sup>	■	–
	± 7% I <sub>sc</sub> <sup>(5)</sup> ≤ 4 x In ± 10% I <sub>sc</sub> <sup>(5)</sup> > 4 x In		± 15% I <sub>sc</sub> <sup>(5)</sup> ≤ 4 x In ± 20% I <sub>sc</sub> <sup>(5)</sup> > 4 x In					
<b>I</b> Instantaneous short circuit protection	I3= 1.5...15 x In	0.1 x In	Instantaneous	–	■	t=k	–	–
	Tolerance <sup>(2)</sup> ± 10%		≤ 30 ms					
<b>G</b> Ground fault protection	I4= 0.2...1 x In <sup>(3)</sup>	0.02 x In	At current I > I4 t4= 0.1 s...1 s	0.05 s	■	t=k	–	■
	Tolerance <sup>(2)</sup> ± 7%		The best of the two given: ± 10% or ± 40 ms					
Tolerance <sup>(2)</sup>	I4= 0.2...1 x In <sup>(3)</sup>	0.02 x In	t4= 0.1 s...1 s (with I= 4 x I4)	0.05 s	■	t=k/I <sup>2</sup>	–	–
	± 7%		± 15%					
<b>Rc</b> Residual Current protection	I <sub>d</sub> = 0.3-0.5-0.6-1-3-5-7-10-20-30 A		t <sub>d</sub> = 0.06-0.1-0.2-0.3- 0.4-0.5-0.8-1-3-4-4.8 s <sup>(3)</sup>		■	t=k	–	–
	Tolerance <sup>(2)</sup> ± 10%							
<b>D</b> Directional short circuit protection	I7= 0.6...10 x In	0.1 x In	At current I > I7 t7= 0.20 s...0.8 s	0.01 s	■	t=k	–	■
	Tolerance <sup>(2)</sup> ± 10%		The best of the two given: ± 10% or ± 40 ms					
<b>U</b> Phase unbalance protection	I6= 5%...90%	5%	t6= 0.5 s...60 s	0.5 s	■	t=k	–	–
	Tolerance <sup>(2)</sup> ± 10%		The best of the two given: ± 20% or ± 100 ms					
<b>OT</b> Protection against overtemperature	cannot be set	–	Instantaneous	–	–	temp=k	–	–
<b>UV</b> Undervoltage protection	U8= 0.5...0.95 x Un	0.01 x In	At current U < U8 t8= 0.1 s...5 s	0.1 s	■	t=k	–	–
	Tolerance <sup>(2)</sup> ± 5%		The best of the two given: ± 20% or ± 40 ms					
<b>OV</b> Overvoltage protection	U9= 1.05...1.2 x Un	0.01 x In	At current U > U9 t9= 0.1 s...5 s	0.1 s	■	t=k	–	–
	Tolerance <sup>(2)</sup> ± 5%		The best of the two given: ± 20% or ± 40 ms					
<b>RV</b> Residual voltage protection	U10= 0.1...0.4 x Un	0.05 Un	At current U > U10 t10= 0.5 s...30 s	0.5 s	■	t=k	–	–
	Tolerance <sup>(2)</sup> ± 5%		The best of the two given: ± 10% or ± 100 ms					

## Protection functions and setting values - PR123

Function	Trip threshold	Threshold steps	Trip Time	Time Step	Can be excluded	Relation t=f(I)	Thermal memory	Zone discrimin.
Reverse power protection RP Tolerance <sup>(2)</sup>	$P_{11} = -0.3 \dots -0.1 \times P_n$ $\pm 10\%$	0.02 P <sub>n</sub>	At current $P < P_{11}$ $t_{11} = 0.5 \text{ s} \dots 25 \text{ s}$ The best of the two given: $\pm 10\%$ or $\pm 100 \text{ ms}$	0.1 s	■	t=k	-	-
Underfrequency protection UF Tolerance <sup>(2)</sup>	$f_{12} = 0.90 \dots 0.99 \times f_n$ $\pm 5\%$	0.01 f <sub>n</sub>	At current $f < f_{12}$ $t_9 = 0.5 \text{ s} \dots 3 \text{ s}$ The best of the two given: $\pm 10\%$ or $\pm 100 \text{ ms}$	0.1 s	■	t=k	-	-
Overfrequency protection OF Tolerance <sup>(2)</sup>	$f_{13} = 1.01 \dots 1.10 \times f_n$ $\pm 5\%$	0.01 f <sub>n</sub>	$t_{10} = 0.5 \text{ s} \dots 3 \text{ s}$ The best of the two given: $\pm 10\%$ or $\pm 100 \text{ ms}$	0.1 s	■	t=k	-	-

(1) The minimum trip value is 1 s, regardless of the type of curve set (self-protection)

(2) These tolerances are valid with the following hypotheses:

- self-powered relay when running and/or auxiliary power supply (without start-up)
- two- or three-phase power supply
- trip time set  $\geq 100 \text{ ms}$

(3) The maximum value for G protection is 1200 A

(4) Non intervention time

(5) Short circuit current

(6) In accordance with IEC 60255-3 Standard

In all cases not covered by the above hypotheses, the following tolerance values are valid:

Trip threshold	Trip time
L Release between 1.05 and 1.25 x I1	$\pm 20\%$
S $\pm 10\%$	$\pm 20\%$
I $\pm 15\%$	$\leq 60 \text{ ms}$
G $\pm 15\%$	$\pm 20\%$
Others	$\pm 20\%$

### Power supply

The PR123 trip unit does not normally require any external power supplies, being self-supplied from the current sensors (CS): to activate the protection and ammeter functions, it is sufficient for at least one phase to have a current load higher than 100 A of the rated current of the rating plug. For the display to come on, at least one phase must have a current load higher than 160 A of the rated current of the rating plug.

The unit ensures fully self-supplied operation. When an auxiliary power supply is present, it is also possible to use the unit with the circuit breaker either open or closed with very low current flowing through.

It is also possible to use an auxiliary power supply provided by the PR030/B portable battery unit (always supplied), which allows the protection functions to be set when the trip unit is not self-supplied.

PR123/P stores and shows all the information needed after a trip (protection tripped, trip current, time, date). No auxiliary supply is required for this functionality.

PR120/V can give power supply to the trip unit when voltage is equal or higher to 85V.

	PR123/P	PR120/D-M <sup>(*)</sup>	PR120/K	PR120/D-BT
Auxiliary power supply (galvanically insulated)	24 V DC $\pm 20\%$	from PR122/PR123	from PR122/PR123	from PR122/PR123
Maximum ripple	5%			
Inrush current @ 24V	$\sim 10 \text{ A}$ for 5 ms			
Rated power @ 24V	$\sim 3 \text{ W}$	+1 W	+1 W	+1 W

#### Note:

PR120/V can give power supply to the trip unit when at least one line voltage is equal or higher to 85V RMS.

(\*) IEC only.



# Trip units and trip curves

## PR123/P

### Functions L-I

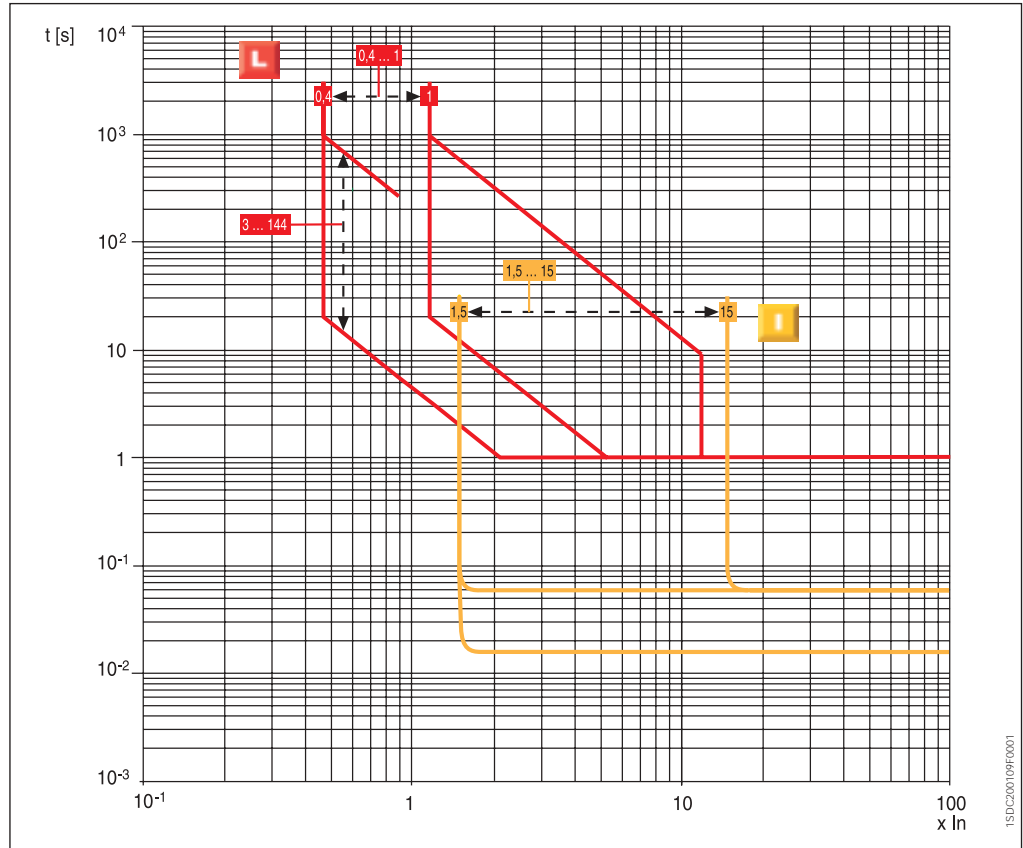

### Functions L-S-I

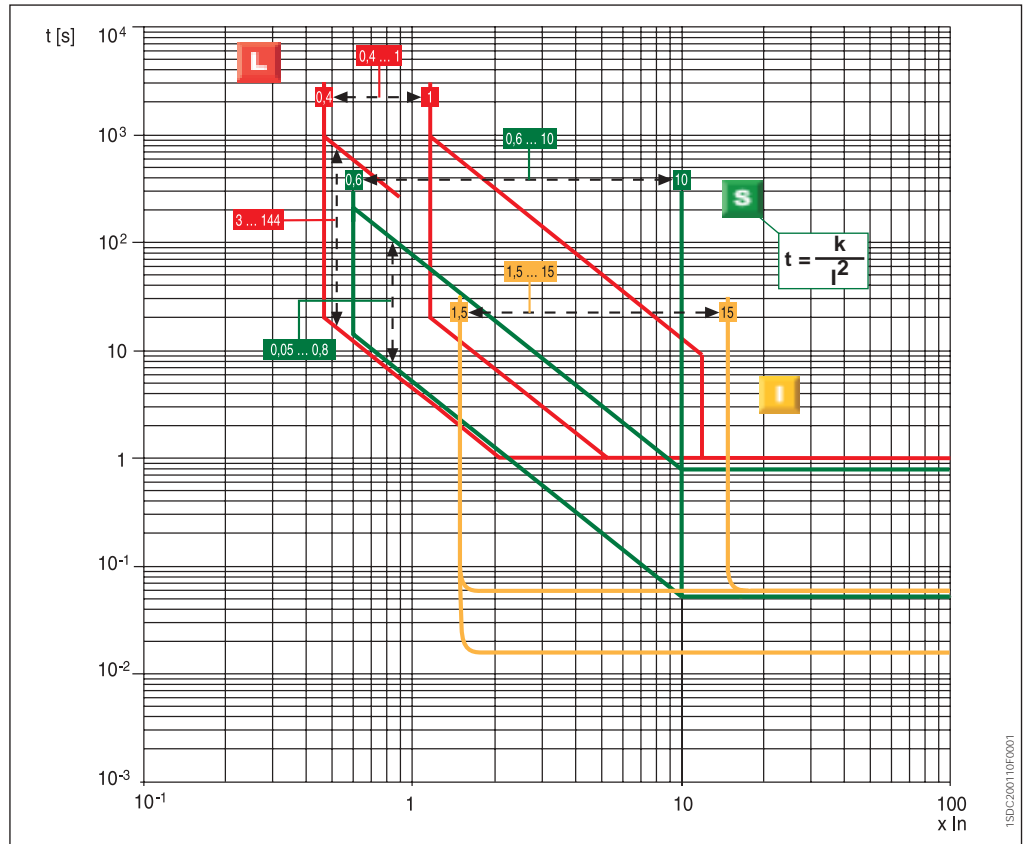

Threshold and trip times tolerances ..... page 3/26

## Function G

Note: The maximum value for G protection is 1200 A

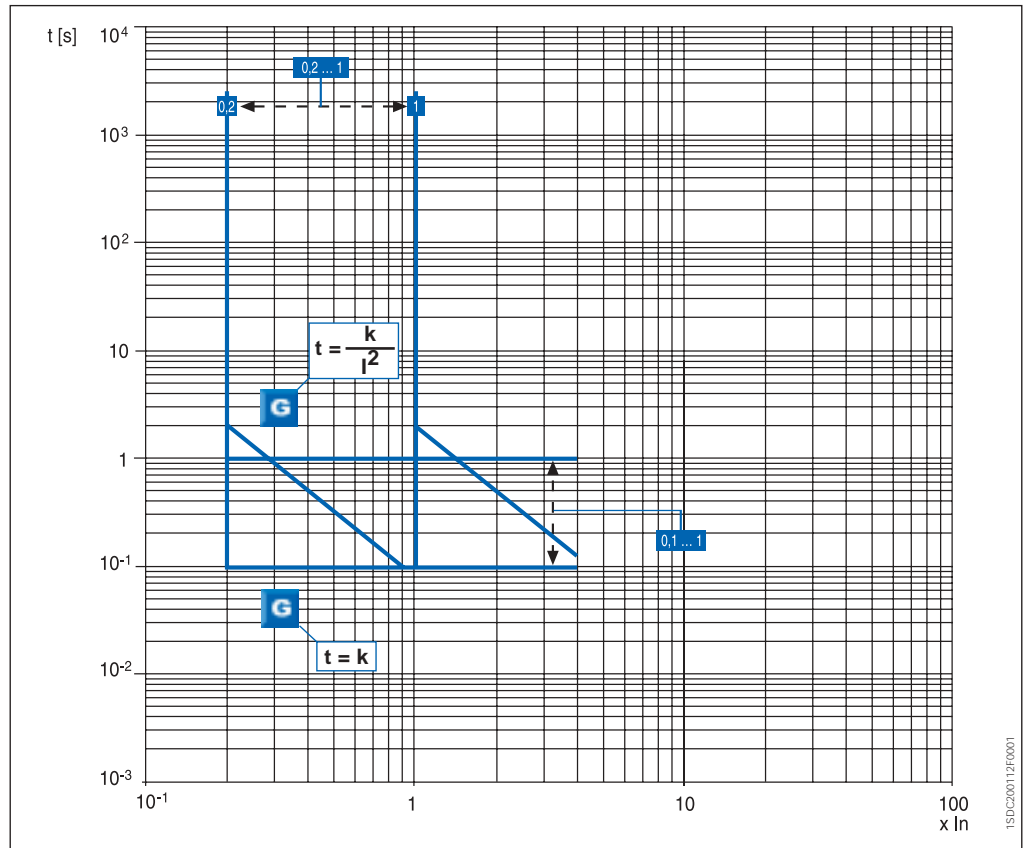

## Function L

According to IEC 60225-3

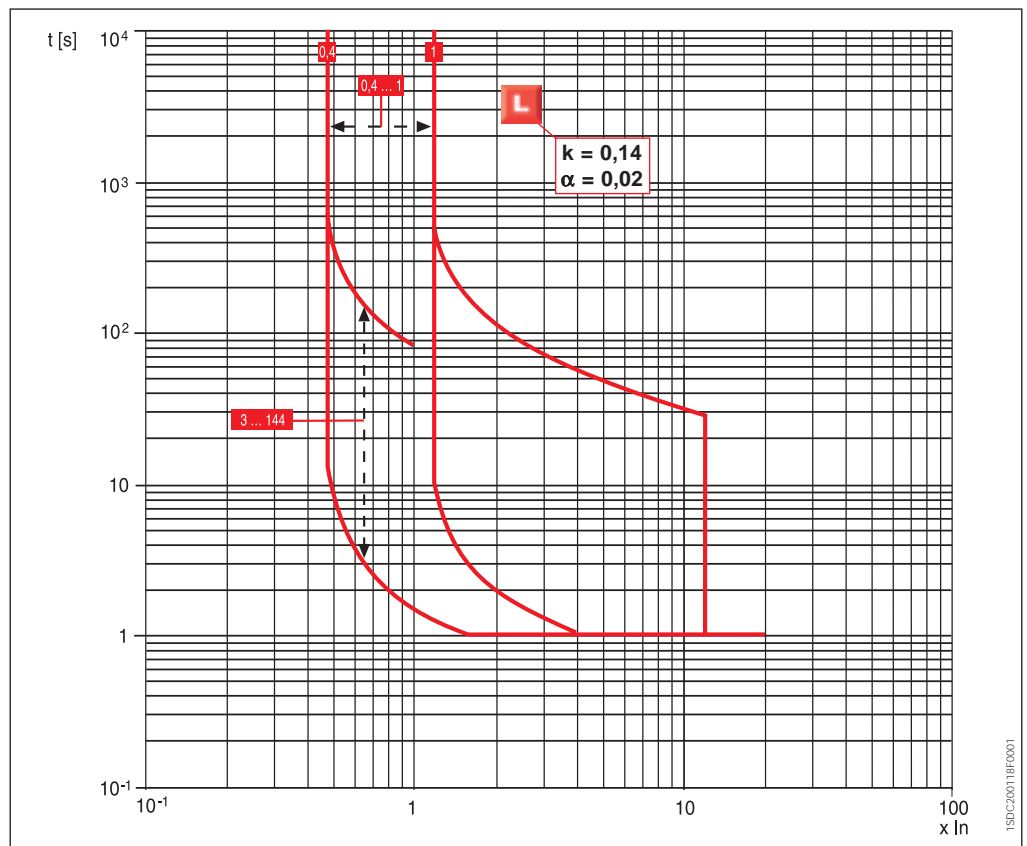

Threshold and trip times tolerances ..... page 3/26



# Trip units and trip curves

## PR123/P

### Function L

According to IEC 60225-3

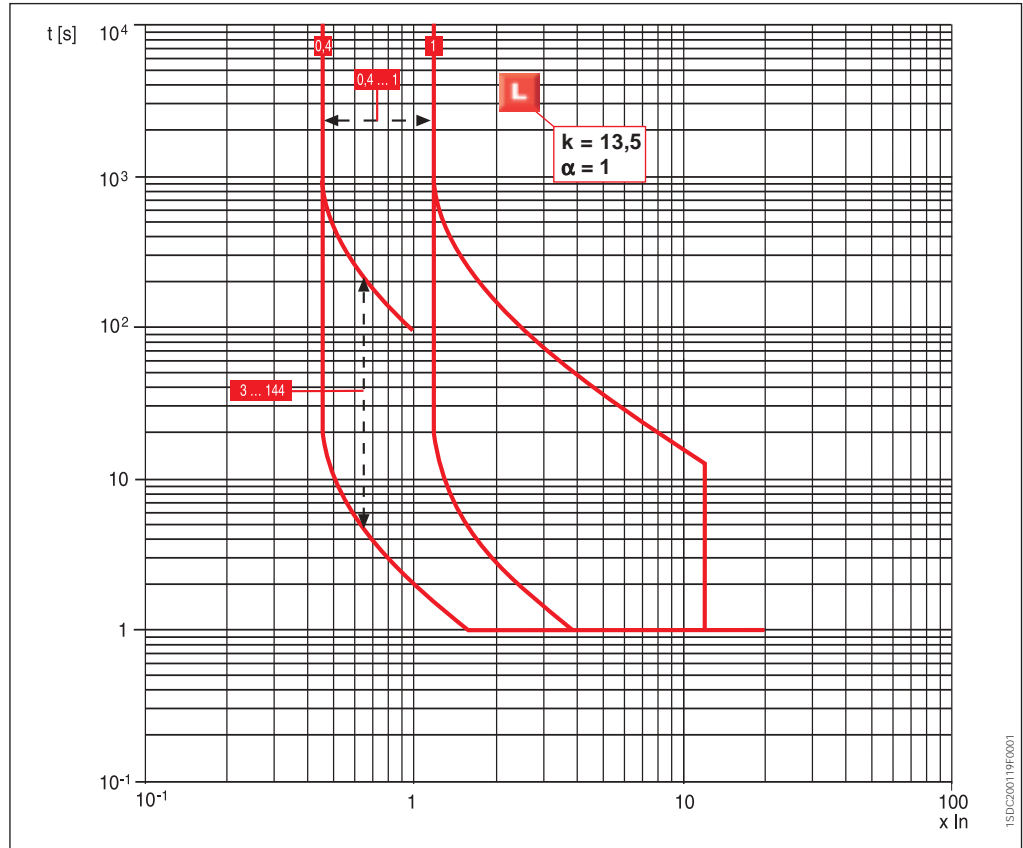

### Function L

According to IEC 60225-3

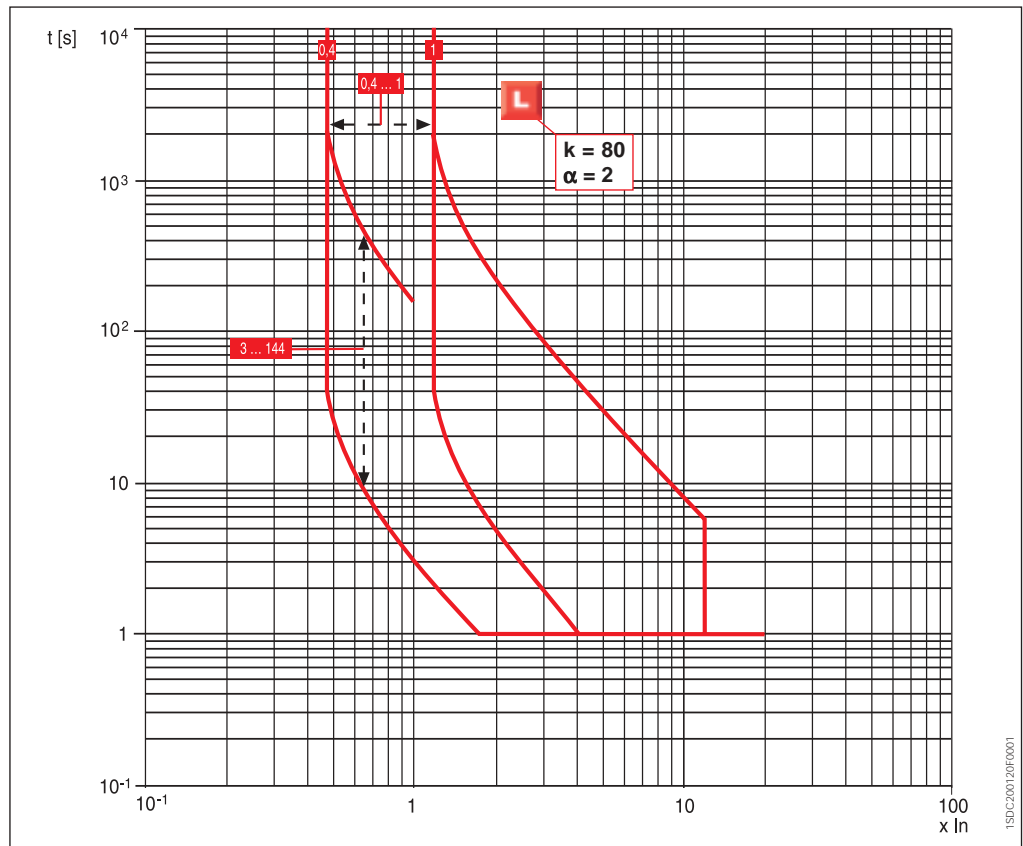

Threshold and trip times  
tolerances ..... page 3/26



### Function D

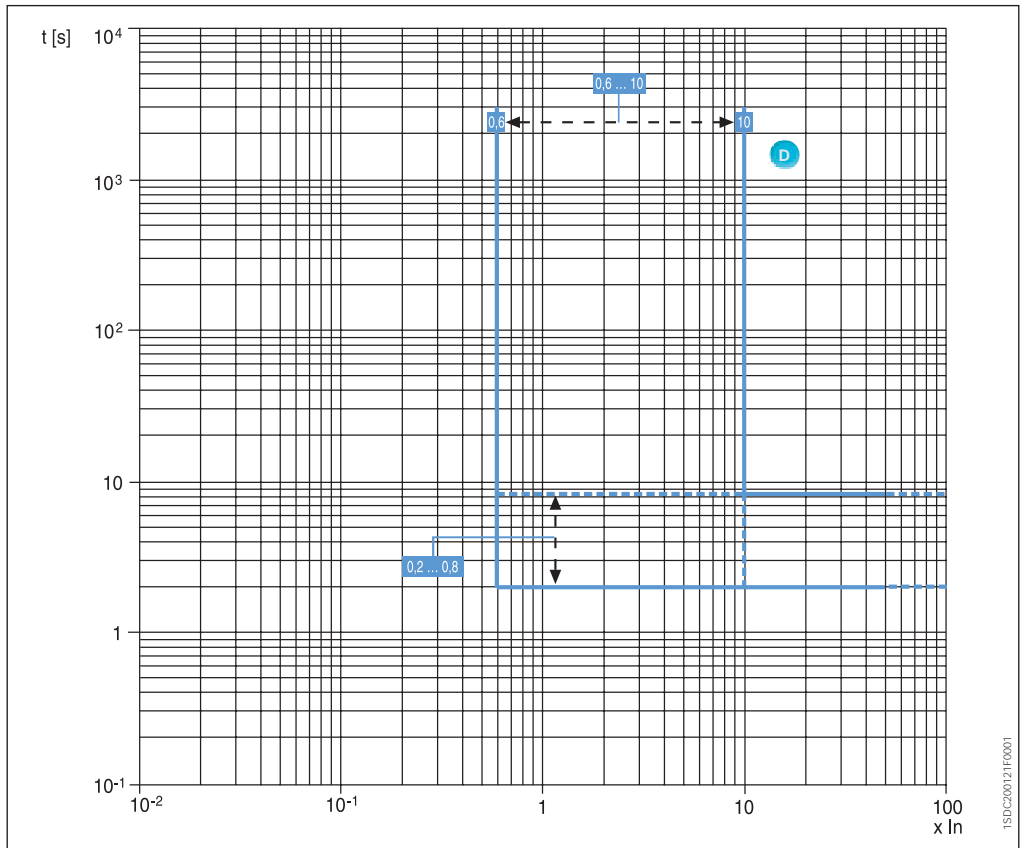

1SD/C2001/2/F0001

### Function U

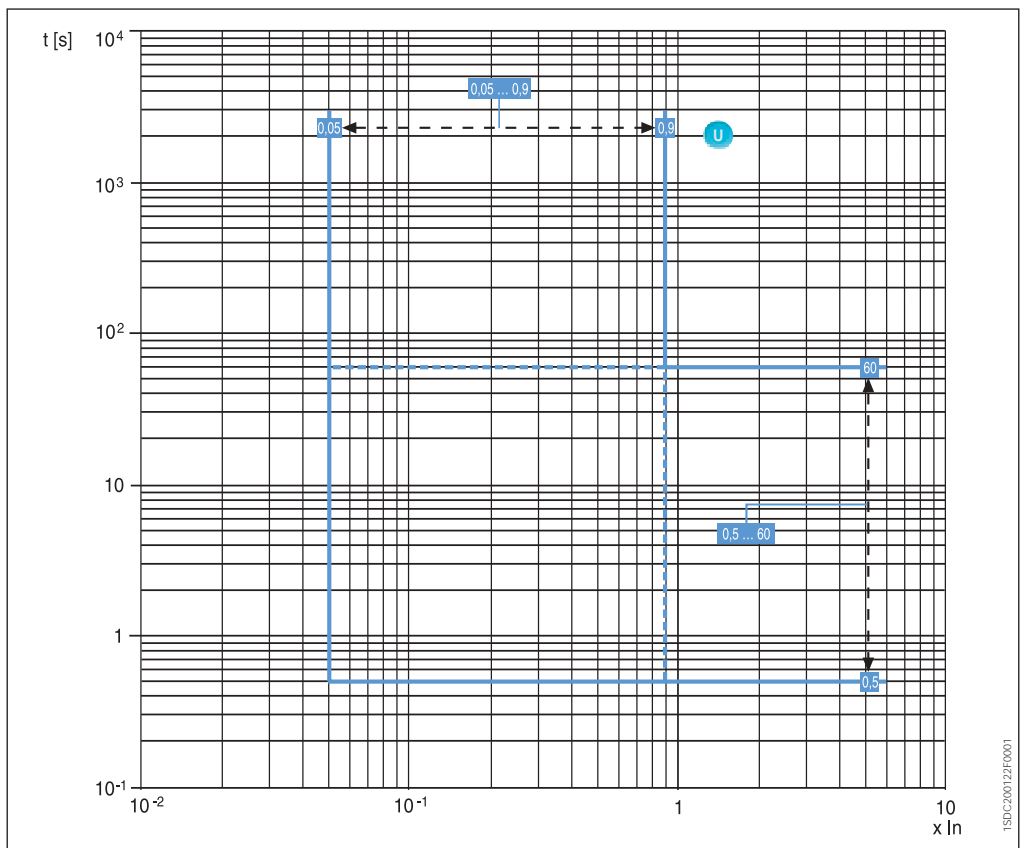

1SD/C2001/2/F0001

Threshold and trip times tolerances ..... page 3/26



# Trip units and trip curves

## PR123/P

### Function UV

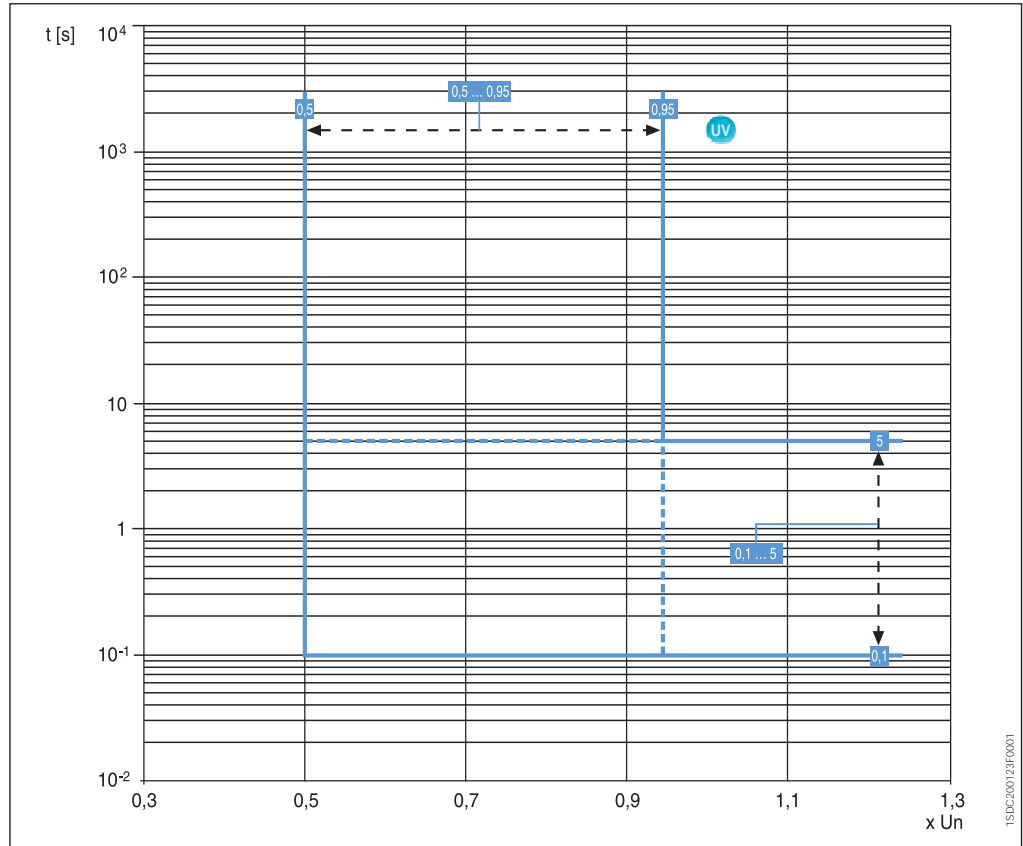

### Function OV

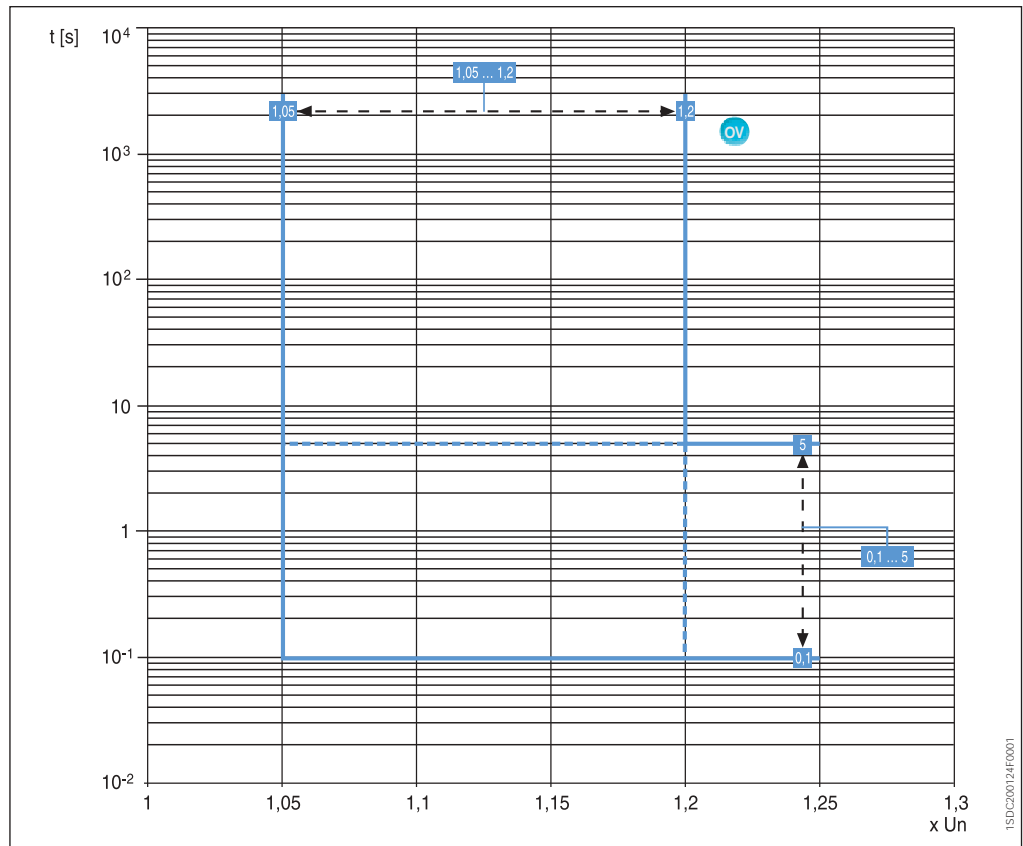

Threshold and trip times tolerances ..... page 3/26

### Function RV

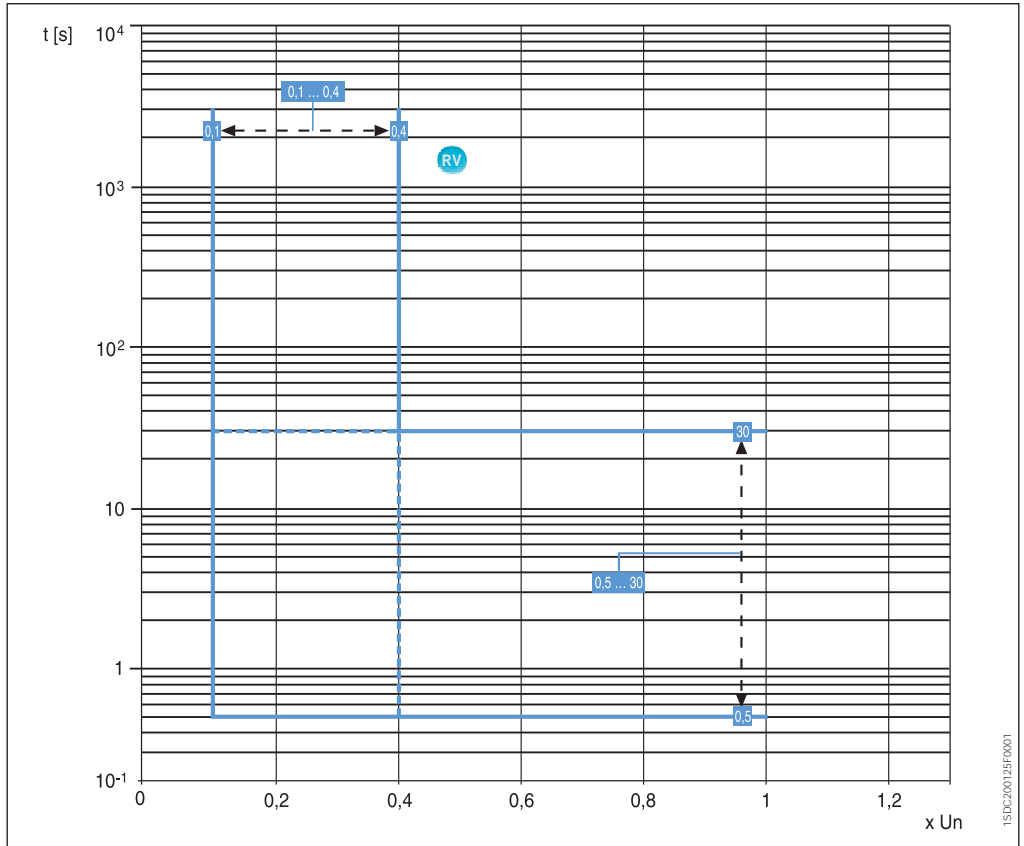

### Function RP

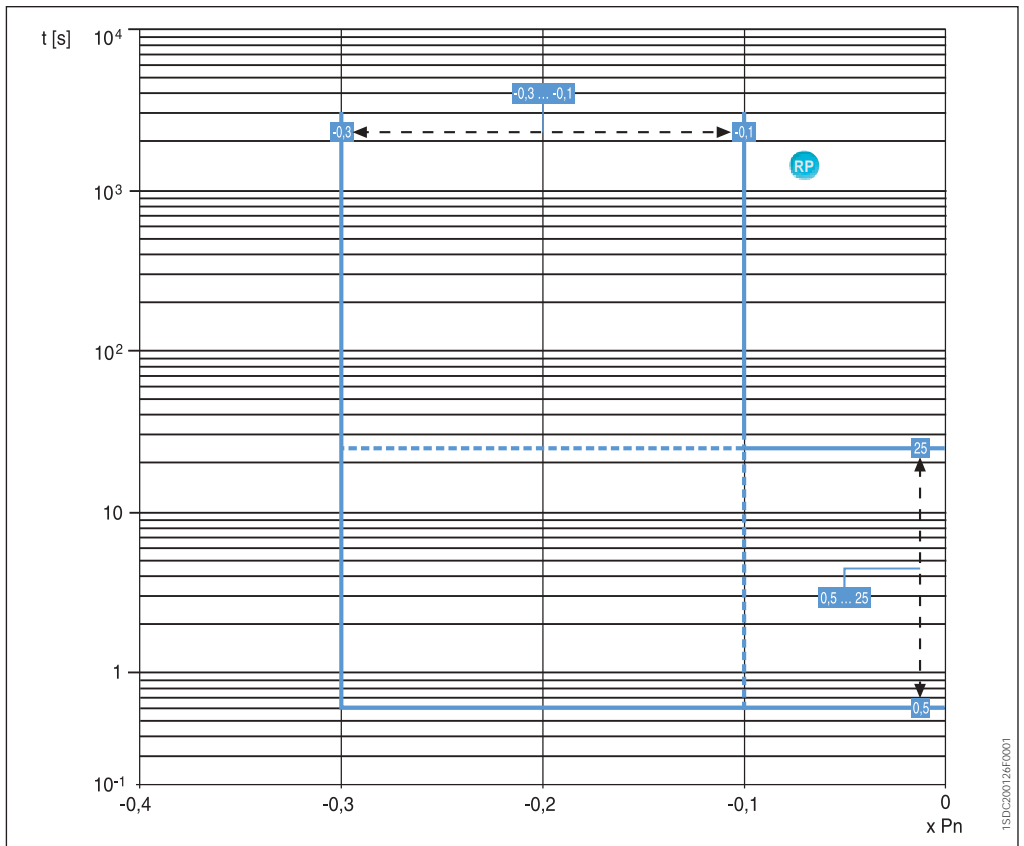

Threshold and trip times  
tolerances ..... page 3/26



## Accessories for trip units

### Optional modules

PR122 and PR123 can be enriched with additional internal modules, increasing the capacity of the trip unit and making these units highly versatile.

#### Electrical signaling contacts: PR120/K Internal Module

This unit, internally connected to PR122/P and PR123/P, allows the remote signaling of alarms and trips of the circuit breaker.

Four independent power relays provided on the PR120/K module enable electrical signaling of the following:

- timing for protections L, S, G (and UV, OV, RV, RP, D, U, OF, UF where applicable);
- protections L, S, I, G, OT, (and UV, OV, RV, RP, D, U, OF, UF where applicable) tripped and other events;
- in addition, by using an external device (PR010/T, BT030, PR120/D-BT), the contacts can be freely configured in association with any possible event or alarm.

PR120/K can also be used as actuator for the Load control function.

In addition the unit can be provided with a digital input signal, enabling the following functions:

- activation of alternative set of parameter (PR123/P only);
- external trip command
- trip reset of the trip unit
- reset of PR120/K power relays

When the digital input is required the power relays have a common connection (see circuit diagrams Chapter 6).

This latest kind of connection must be specified in the order when required together with the circuit breaker. When PR120/K is ordered as loose accessory both of the configurations are possible.

The auxiliary 24V DC power supply is needed for the unit (shown by a green Power LED). Four yellow LEDs show the status of each output relay.

The use of Voltage Transformers is mandatory for rated voltages higher than 690V.



1SDC20008000001

#### Specifications of the signaling relays

Type	Monostable STDP
Maximum switching power (resistive load)	100 W/1250 VA
Maximum switching voltage	130 V DC/250 V AC
Maximum switching current	5 A
Breaking capacity (resistive load)	
@ 30V DC	3.3 A
@ 250V AC	5 A
Contact/coil insulation	2000 V eff (1 min@ 50 Hz)

#### PR120/V Measurement Module

This optional internal module can be added to PR122, and it is supplied as standard in PR123. It measures and processes the phase and neutral voltages, are transferring these values to the protection trip unit by means of its internal bus in order to achieve a series of protection and measurement features. It can be connected at any time to PR122/P, which recognizes it automatically without the need of any configuration.

PR122 does not normally require any external connection or Voltage Transformer, since it is connected internally to the lower terminals of Emax. When necessary, the connection of voltage pick-ups can be moved to any other points (i.e. upper terminals), by using the alternative connection located in the terminal box.

When ordered as a loose accessory, PR122 is provided with all the possible connections, internal or through the terminal box.

The module is provided with a Power LED and a sealable switch for the dielectric test.



1SDC200114F0001

3



### PR120/D-M Communication Module (IEC only)

PR120/D-M communication module is the solution for connecting Emax to a Modbus network, allowing the remote supervision and control of the circuit breaker.

It is suitable for PR122/P and PR123/P trip units. As for PR120/V this module can be added at any time to the protection trip unit and its presence is automatically recognized. When ordered separately from the circuit breakers it is supplied complete of all the accessories needed for its installation, such as precabled auxiliary switches and cables for signaling the circuit breaker status (springs, position inserted). Refer to circuit diagram page 6/9 for details about connections.

The list of available functions can be found on page 3/38.

It is provided with three LEDs on the front side:

- Power LED
- Rx/Tx LEDs



### PR120/D-BT Wireless Communication Module

PR120/D-BT is the innovative wireless communication module, based on Bluetooth standard. It allows the communication among the PR122/P and PR123/P Protection trip units and a PDA or a Notebook with a Bluetooth port. This device is dedicated to the use with SD-Pocket application (see in the following the features of this application).

The module can be powered by means of te 24V DC auxiliary supply or by means of PR030/B battery unit.

It is provided with four LEDs on the front side:

- Power LED
- Rx/Tx LEDs
- Bluetooth LED, showing the activity of Bluetooth communication

PR120/D-BT can be connected at any time to the protection trip unit.

### BT030

BT030 is a device to be connected on Test connector of PR121/P, PR122/P and PR123/P. It allows Bluetooth communication among the Protection trip unit and a PDA or a Notebook with a Bluetooth port. BT030 can also be used with Tmax circuit breakers equipped with PR222DS/PD. This device is dedicated to the use with SD-Pocket application.

BT030 can provide the power supply needed to energize itself and the protection trip unit by means of a Li-ion rechargeable battery.

### PR030/B power supply unit

This accessory, always supplied with the PR122 and PR123 range of trip units, makes it possible to read and configure the parameters of the unit whatever the status of the circuit breaker (open-closed, in test isolated or racked-in position, with/without auxiliary power supply).

PR030/B is also needed for reading trip data if the trip occurred more than 48 hours earlier and the trip unit was no longer powered.

An internal electronic circuit supplies the unit for approximately 3 consecutive hours for the sole purpose of reading and configuring data.

In relation to the amount of use, battery life decreases if the PR030/B accessory is also used to perform the Trip test & Auto test.

### HMI030

This accessory, suitable for all protection trip units, is designed for the installation on the front side of the switchboard. It consists of a graphic display where all the measurements and alarms/events of the trip unit are shown. The user can browse the measurements by using the navigation pushbuttons, similarly to PR122/P and PR123/P. Thanks to the high precision level, the same of the protection trip units, the device can replace the traditional instrumentation, without the need for current/voltage transformers. The unit requires only a 24 V DC power supply. In fact HMI030 is connected directly to the protection trip unit via a serial line.



## Accessories for trip units

### PR010/T configuration test unit

The PR010/T unit is an instrument capable of performing the functions of testing, programming and reading parameters for the trip units equipping Emax low voltage air circuit breakers.

In particular, the test function involves the following units:

- PR121 (all versions)
- PR122 (all versions)
- PR123 (all versions)

whereas the parameter programming and reading functions regard the range of PR122 and PR123 trip units.

All of the functions mentioned can be carried out "on board" by connecting the SACE PR010/T unit to the front multi-pin connector on the various protection units. Special interfacing cables supplied with the unit must be used for this connection.

The human-machine interface takes the form of a touchpad and multi-line alphanumeric display.

The unit also has two LEDs to indicate, respectively:

- POWER-ON and STAND BY
- battery charge state.

Two different types of test are available: automatic (for PR121, PR122 and PR123) and manual. By connection to a PC (using the floppy-disc supplied by ABB), it is also possible to upgrade the software of the PR010/T unit and adapt the test unit to the development of new products.

It is also possible to store the most important test results in the unit itself, and to send a report to the personal computer with the following information:

- type of protection tested
- threshold selected
- curve selected
- phase tested
- test current
- estimated trip time
- measured trip time
- test results.

At least 5 complete tests can be stored in the memory. The report downloaded onto a PC allows creation of an archive of tests carried out on the installation.

In automatic mode, the PR010/T unit is capable of testing the following with the PR122 range:

- protection functions L, S, I,
- G protection function with internal transformer,
- G protection function with toroid on the transformer star centre,
- monitoring of correct microprocessor operation.

The unit can also test the following protections of PR122 equipped with PR120/V:

- overvoltage protection function OV,
- undervoltage protection function UV,
- residual voltage protection function RV,
- phase unbalance protection function U.

The PR010/T unit is portable and runs on rechargeable batteries and/or with an external power supply (always supplied) with a rated voltage of 100-240V AC/12V DC.

The standard version of the PR010/T unit includes:

- PR010/T test unit complete with rechargeable batteries
- TT1 test unit
- 100 - 240V AC/12V DC external power supply with cord
- cables to connect the unit and connector
- cable to connect the unit and computer (RS232 serial)
- user manual and floppy-disc containing application software
- plastic bag.



150C200129F0001



# Communication devices

## PR021/K signaling unit

The PR021/K signaling unit can convert the digital signals supplied by the PR121, PR122 and PR123 trip unit into electrical signals, via normally open electrical contacts (potential free).

The unit is connected to the protection trip unit by means of a dedicated serial line through which all of the information about the activation status of the protection functions flows. The corresponding power contacts are closed based on this information.

The following signals/contacts are available:

- overload pre-alarm L (the alarm signal remains active throughout the overload, until the trip unit is tripped)
- timing and tripping of any protections (the trip signals of the protections remain active during the timing phase, and after the trip unit has tripped)
- protection I tripped
- timing and overtemperature threshold exceeded ( $T > 185\text{ °F} / 85\text{ °C}$ )
- two load control contacts (connection and disconnection of a load, or disconnection of two loads)
- trip unit tripped
- dialogue fault on a serial line (connecting the protection and signaling units)
- phase unbalance.

Setting a dip-switch allows up to seven signal contacts to be freely configured in PR122-PR123, including: directional protection D tripped, under- and overvoltage UV and OV tripped, reverse power RP tripped, and others.

Two contacts available on the PR021/K unit (load control) can pilot a circuit breaker shunt trip and closing coil. These contacts allow various applications, including load control, alarms, signals and electrical locks.

Pressing the Reset pushbutton resets the status of all signals.

The unit also contains ten LEDs to visually signal the following information:

- "Power ON": auxiliary power supply present
- "TX (Int Bus)": flashing synchronized with dialogue with the Internal Bus
- eight LEDs associated with the signaling contacts.

The table below lists the characteristics of the signaling contacts available in the PR021/K unit.

Auxiliary power supply	24 V DC $\pm$ 20%
Maximum ripple	5%
Rated power @ 24 V	4.4 W

Specifications of the signaling relays	
Type	Monostable STDP
Maximum switching power (resistive load)	100 W/1250 VA
Maximum switching voltage	130 V DC/250 V AC
Maximum switching current	5 A
Breaking capacity (resistive load)	
	@ 30V DC 3.3 A
	@ 250V AC 5 A
Contact/coil insulation	2000 V eff (1 min@ 50 Hz)



# Communication devices

## Measurement, signaling and available data functions

Details about functions available on PR122/P, PR123/P trip units with PR120/D-M (IEC only) are listed in the table below:

	PR122/P + PR120/D-M	PR123/P + PR120/D-M
<b>Communication functions</b>		
Protocol	Modbus RTU	Modbus RTU
Physical layer	RS-485	RS-485
Maximum baudrate	19200 bps	19200 bps
<b>Measuring functions</b>		
Phase currents	■	■
Neutral current	■	■
Ground current	■	■
Voltage (phase-phase, phase-neutral, residual)	opt. <sup>(1)</sup>	■
Power (active, reactive, apparent)	opt. <sup>(1)</sup>	■
Power factor	opt. <sup>(1)</sup>	■
Frequency and peak factor	opt. <sup>(1)</sup>	■
Energy (active, reactive, apparent)	opt. <sup>(1)</sup>	■
Harmonic analysis up to the 40 <sup>th</sup> harmonic		■
<b>Signaling functions</b>		
LED: auxiliary power supply, warning, alarm	■	■
Temperature	■	■
Indication for L, S, I, G and other protection	opt.	■
<b>Available data</b>		
Circuit breaker status (open, closed)	■	■
Circuit breaker position (racked-in, racked-out)	■	■
Mode (local, remote)	■	■
Protection parameters set	■	■
Load control parameters	■	■
<b>Alarms</b>		
Protection L	■	■
Protection S	■	■
Protection I	■	■
Protection G	■	■
Protection T	■	■
Trip unit command for fault failure	■	■
Undervoltage, overvoltage and residual voltage (timing and trip) protection	opt.	■
Reverse power protection (timing and trip)	opt.	■
Directional protection (timing and trip)	■	■
Underfrequency/overfrequency protection (timing and trip)	opt.	■
Phases rotation		■
<b>Maintenance</b>		
Total number of operations	■	■
Total number of trips	■	■
Number of trip tests	■	■
Number of manual operations	■	■
Number of separate trips for each protection function	■	■
Contact wear (%)	■	■
Record data of last trip	■	■
<b>Operating mechanisms</b>		
Circuit breaker open/close	■	■
Reset alarms	■	■
Setting of curves and protection thresholds	■	■
Synchronize system time	■	■
<b>Events</b>		
Status changes in circuit breaker, protections and all alarms	■	■

(1) with PR120/V

3



---

---

## SD-Pocket

SD-Pocket is an application designed to connect the new protection trip units to a PDA or to a personal computer. This means it is now possible to use wireless communication to:

- configure the protection threshold function
- monitor measurement functions, including reading of data recorded in data logger (PR122/PR123)
- verify the status of the circuit breaker (i.e. number of operations, trip data, according to the trip unit connected).

SD-Pocket application scenarios include:

- during start-up of switchgear, with rapid and error-free transfer of the protection parameters to the trip units (also using the dedicated exchange file directly from Docwin);
- during normal installation service, gathering information on the circuit breaker and load conditions (last trip information, runtime currents, and other information).

To use all these functions, it is sufficient to have a PDA with MS Windows Mobile 2003 and BT interface or a personal computer with MS Windows2000 OS and new PR120/D-BT or PR030/B Bluetooth interface devices.

SD-Pocket is freeware and it can be downloaded from the BOL website (<http://bol.it.abb.com>). Its use does not require the presence of dialogue units for the trip units.



# Emax

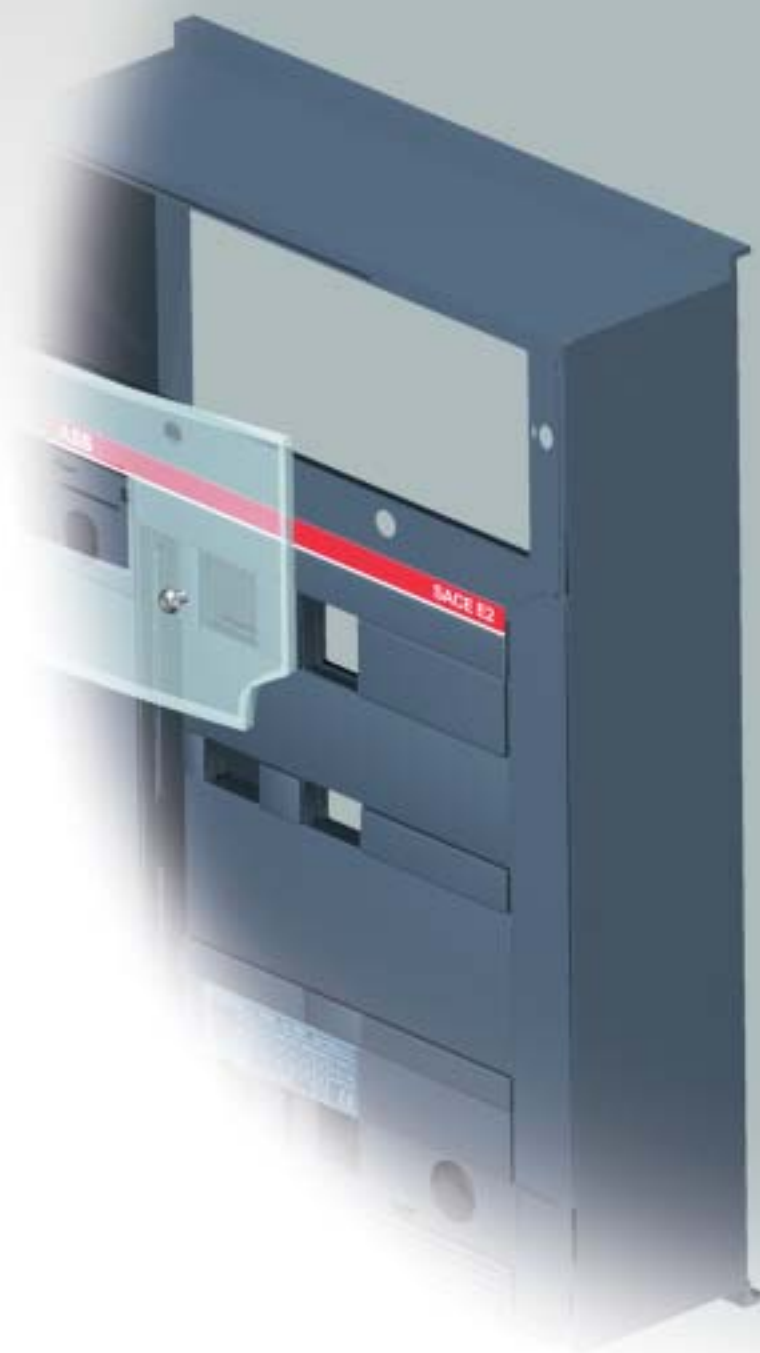

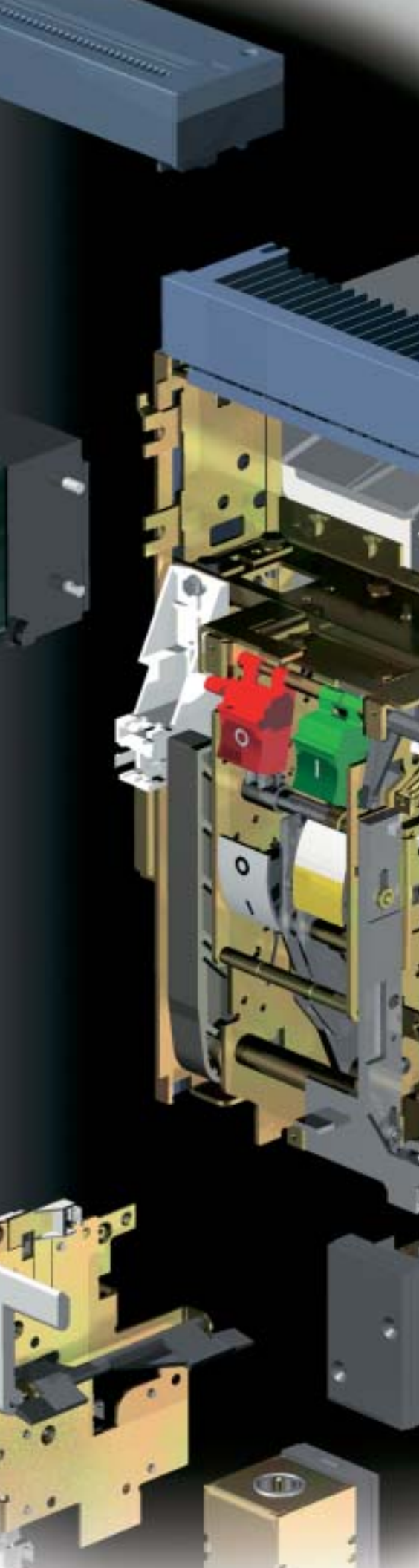

## Contents

Functions of the accessories .....	4/2
Accessories supplied as standard .....	4/3
Accessories supplied on request .....	4/4
Shunt trip and closing coils .....	4/6
Undervoltage release .....	4/8
Gearmotor for the automatic charging of closing springs .....	4/10
Bell alarm .....	4/11
Auxiliary contacts .....	4/12
Current sensors and operation counters .....	4/15
Mechanical safety locks .....	4/16
Transparent protective covers .....	5/18
Mechanical interlock .....	4/19
Controller for Automatic Transfer Switch - ATS010 (IEC only) .....	4/22
Spare parts .....	4/25



# Functions of the accessories

The following table lists a few functions that can be obtained by selecting the appropriate accessories. Several of the functions listed can be needed at the same time depending on how the circuit breaker is used. See the related section for a detailed description of the individual accessories.

Function	Components
Electrical operated	<ul style="list-style-type: none"> <li>• Shunt trip</li> <li>• Closing coil</li> <li>• Gearmotor for the automatic charging of closing springs</li> </ul>
Remote signaling or actuation of automatic functions depending on the state (open-closed) or position ( <i>racked-in</i> , <i>test isolated</i> , <i>racked-out</i> ) of the circuit breaker.	<ul style="list-style-type: none"> <li>• Auxiliary contacts of open-closed circuit breaker</li> <li>• Auxiliary contacts of circuit breaker <i>racked-in</i>, <i>test isolated</i>, <i>racked-out</i> (draw out circuit breaker only)</li> <li>• Bell alarm</li> <li>• Contact for signaling undervoltage release de-energized</li> <li>• Contact for signaling springs charged</li> </ul>
Remote opening for various needs, including: – manual emergency control – opening dependent on tripping of other interruption devices or system automation needs <sup>(1)</sup> .	<ul style="list-style-type: none"> <li>• Opening or undervoltage release</li> </ul>
Automatic opening of the circuit breaker for undervoltage (for example, when operating asynchronous motors)	<ul style="list-style-type: none"> <li>• Instantaneous or time delay undervoltage release (IEC only) <sup>(2)</sup></li> <li>• Contact for signaling undervoltage release energized</li> </ul>
Increased degree of protection	<ul style="list-style-type: none"> <li>• IP54 door protection</li> </ul>
Mechanical safety locks for maintenance or functional requirements for interlocking two or more circuit breakers	<ul style="list-style-type: none"> <li>• Kirk key provision</li> <li>• Key lock in open position</li> <li>• Padlock device in open position</li> <li>• Key lock and padlocks in <i>racked-in</i>, <i>test isolated</i>, <i>racked-out</i> position</li> </ul>
Automatic switching of power supplies	<ul style="list-style-type: none"> <li>• Mechanical interlock between two or three circuit breakers</li> <li>• Automatic transfer switch - ATS010 (IEC only)</li> </ul>

(1) Examples:  
 – circuit breakers on Low Voltage side of parallel transformers that must open automatically when the Medium Voltage side device opens.  
 – automatic opening for control by external relay (undervoltage, residual current, etc.).

(2) The time-delay device is recommended when unwanted operation due to temporary voltage drops, is to be avoided (for functional or safety reasons).



---

## Accessories supplied as standard

---

The following standard accessories are supplied depending on the circuit breaker version:

---

### Fixed circuit breaker:

- flange for switchboard compartment door
- support for service releases
- four auxiliary contacts for electrical signaling of circuit breaker open/closed (they are not supplied with the switch version)
- mechanical indication of trip (\*)
- terminal box for connecting outgoing auxiliaries
- horizontal rear terminals
- lifting plate

**Note:**

(\*) not supplied with the switch version

---

### Draw out circuit breaker:

- flange for switchboard compartment door
- support for service releases
- four auxiliary contacts for electrical signaling of circuit breaker open/closed
- mechanical indication of trip (\*)
- sliding contacts for connecting outgoing auxiliaries
- horizontal rear terminals
- anti-insertion lock for circuit breakers with different continuous current ratings
- racking-out crank handle
- lifting plate
- anti-racking-out device when springs are charged (fail safe)

**Note:**

(\*) not supplied with the switch version



## Accessories supplied on request

### All the accessories

#### Circuit breaker

- 1a) Shunt trip/closing coil (YO/YC) and second shunt trip (YO2)
- 1b) SOR test unit (IEC only)
- 2a) Undervoltage release (YU)
- 2b) Time-delay device for undervoltage release (D) (IEC only)
- 3) Gearmotor for the automatic charging of the closing springs (M)
- 4a) Bell alarm
- 4b) Bell alarm with remote reset command
- 5a) Electrical signaling of circuit breaker open/closed <sup>(1)</sup>
- 5b) External supplementary electrical signaling of circuit breaker open/closed
- 5c) Electrical signaling of circuit breaker racked-in/test isolated/racked-out
- 5d) Contact signaling closing springs charged
- 5e) Contact signaling undervoltage release de-energized (C. Aux YU)
- 6a) External current sensors for neutral conductor outside circuit breaker
- 6b) Homopolar toroid for the main power supply grounding conductor (star center of the transformer)
- 7) Mechanical operation counter
- 8a) Lock in open position: key
- 8b) Lock in open position: padlocks
- 8c) Circuit breaker lock in racked-in/test isolated/racked-out position
- 8d) Accessories for lock in test isolated/racked-out position
- 8e) Padlock device for safety shutter
- 8f) Mechanical lock for compartment door
- 8g) Anti-racking-out device when the springs are charged (FAIL SAFE)
- 9a) Protection for opening and closing pushbuttons
- 9b) IP54 door protection
- 10) Mechanical interlock
- 11) Controller for Automatic Transfer Switch - ATS010 (IEC only)

#### CAPTION

- Accessory on request on fixed circuit breaker or moving part
- Accessory on request on cradle
- Accessory on request on moving part







# Shunt trip and closing coils

(1) The minimum impulse current must be 100 ms

(2) If the shunt trip is permanently connected to the power supply, wait at least 30 ms before sending the command to the closing coil.

## 1a) Shunt trip/closing coil (YO/YC) and second shunt trip (YO2)

They allow the remote control of the circuit breaker. The accessory is the same and the function depends on the installation position on the circuit breaker. It can be used for either of these applications.

Given the characteristics of the circuit breaker operating mechanism, opening (with the circuit breaker closed) is always possible, while closing is only possible when the closing springs are charged. The release can operate with either direct current or alternating current. This release can be operated by a pulse <sup>(1)</sup>, or with a permanent signal <sup>(2)</sup>.

For safety reasons, Emax can be equipped with a second shunt trip, mounted on a special support in alternative to the UVR.

If the closing coil is powered with a continuous signal, the presence of the anti-pumping device requires after an opening operation to momentarily de-energize the closing coil.

Reference figure in circuit diagrams: YO (4-5) - YC (2-3) - YO2 (8)



15DC200103F0003



15DC200103F0003

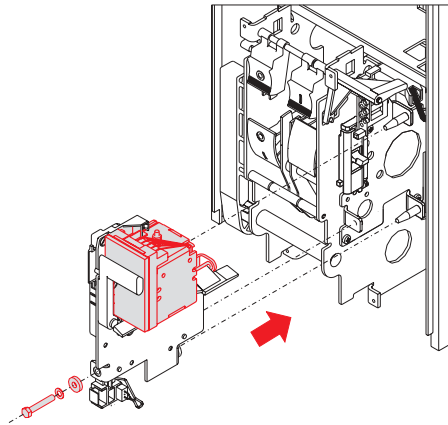

15DC200104F0003

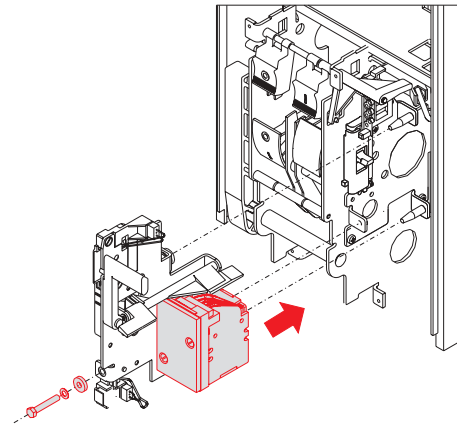

15DC200105F0003

Characteristics		
Power supply (Un):	24 V DC	125-127 V AC/DC
	30 V AC/DC	220-240 V AC/DC
	48 V AC/DC	250 V AC/DC
	60 V AC/DC	380-400 V AC
	110-120 V AC/DC	440-480 V AC
Operating limits:	(YO-YO2): 70% ... 110% Un	
	(YC): 85% ... 110% Un	
Inrush power (Ps):	DC = 200 W	
Inrush time ~100 ms	AC = 200 VA	
Continuous power (Pc):	DC = 5 W	
	AC = 5 VA	
Opening time (YO- YO2):	(max) 60 ms	
Closing time (YC)	(max) 80 ms	
Insulation voltage:	2500 V 50 Hz (for 1 min)	



## 1b) SOR Test Unit (IEC only)

Under particularly severe operating conditions or simply for remote control of the circuit breaker, the shunt trip is widely used as an accessory for the Emax series of power circuit breakers.

The right working of all functions of this accessory is a necessary condition to guarantee a high level of safety in the installation: this means there is the need to have a device available which cyclically checks correct operation of the release, signaling any malfunctions.

The SOR control and monitoring Test Unit ensures continuity of shunt trips with a rated operating voltage between 24 V and 250 V (AC and DC), as well as the functions of the opening coil electronic circuit.

Continuity is checked cyclically with an interval of 20s between tests.

The unit has LEDs on the front, which provide the following information:

- POWER ON: power supply present
- YO TESTING: test in progress
- TEST FAILED: signal following a failed test or lack of auxiliary power supply
- ALARM: signal following three failed tests.

Two relays with one change-over are also available, which allow remote signaling of the following two events:

- failure of a test (resetting takes place automatically when the alarm stops )
- failure of three tests (resetting only occurs by pressing the manual RESET on the front of the unit)

### Characteristics

Auxiliary power	24 V ... 250 V AC/DC
Maximum interrupted current	6 A
Maximum interrupted voltage	250V AC



# Undervoltage release

## 2a) Undervoltage release (YU)

The undervoltage release opens the circuit breaker when there is a significant voltage drop in the power supply. It can be used also to open the circuit breaker (using normally closed pushbuttons), as a lock in closing position. The power supply is therefore obtained on the supply side of the circuit breaker or from an independent source. The circuit breaker can be closed only when the release is energized. The release can operate with either direct current or alternating current.

When the voltage drops down below the 10% of the rated voltage, the UVR trips the breaker.

The circuit breaker can be closed with voltage higher than of 85%.

It can be fitted with a contact to signal when the undervoltage release is energized (C. aux YU; see accessory 5d).

**Note**

With the undervoltage release, the use of the anti-racking-out device is not allowed.

Reference figure in circuit diagrams: YU (6)



1SDC200107F0003

Characteristics		
Power supply (Un):	24 V DC	125-127 V AC/DC
	30 V AC/DC	220-240 V AC/DC
	48 V AC/DC	250 V AC
	60 V AC/DC	380-400 V AC
	110-120 V AC/DC	440-480 V AC
Inrush power (Ps):	DC = 200 W	
	AC = 200 VA	
Continuous power (Pc):	DC = 5 W	
	AC = 5 VA	
Opening time (YU)	30 ms	
Insulation voltage:	2500 V 50 Hz (for 1 min)	

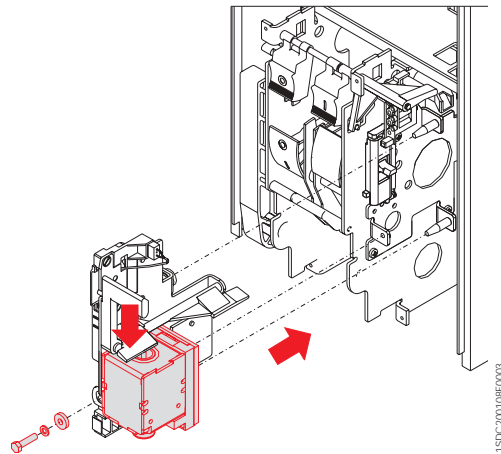

1SDC200108F0003

4



1SDC200109F0003

## 2b) Time-delay device for undervoltage release (D) (IEC only)

The undervoltage release can be combined with an electronic time-delay device mounted outside the circuit breaker. Use of the delayed undervoltage release is recommended to prevent tripping when the power supply network can be subject to brief voltage drops.

The time-delay device must be used with an undervoltage release with the same operating voltage.

Reference figure in circuit diagrams: YU +D (7)

### Characteristics

Power supply (D):	24-30 V DC
	48 V AC/DC
	60 V AC/DC
	110-127 V AC/DC
	220-250 V AC/DC
Adjustable opening time (YU+D):	0.5-1-1.5-2-3 s



# Gearmotor for the automatic charging of closing springs

## 3) Gearmotor for the automatic charging of closing springs (M)

This accessory automatically charges the closing springs of the circuit breaker operating mechanism. The gearmotor immediately recharges the closing springs after closing the circuit breaker.

The closing springs can, however, be charged manually (using the relative operating lever) in the event of a power supply failure or during maintenance.

It is always supplied with a limit switch for signaling that the closing springs are charged (see accessory 5d).

Reference figure in circuit diagrams: M (1)



1SDC200110F0003

Characteristics	
Power supply	24-30 V AC/DC
	48-60 V AC/DC
	100-130 V AC/DC
	220-250 V AC/DC
Operating limits:	85%...110% Un
Inrush power (Ps):	DC = 500 W
	AC = 500 VA
Rated power (Pn):	DC = 200 W
	AC = 200 VA
Inrush time	0.2 s
Charging time:	4-5 s
Insulation voltage:	2500 V 50 Hz (for 1 min)

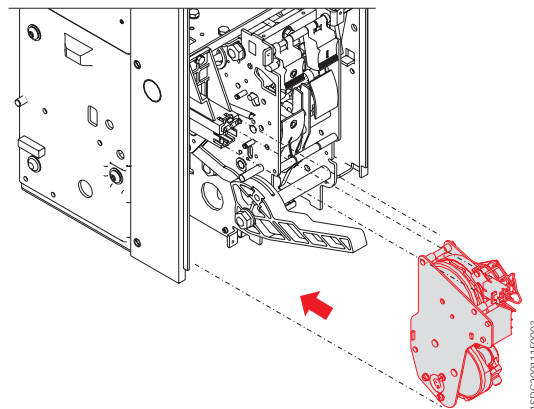

1SDC200110F0003



# Bell alarm

## 4) Bell alarm

The following signals are available after the trip unit tripped.

### 4a) Bell alarm

Allows the local (mechanical accessory supplied as standard) and remote signaling (electrical by means of changeover switch) that the circuit breaker is open following operation of the trip units. The mechanical signaling pushbutton must be rearmed to reclose the circuit breaker.

Reference figure in circuit diagrams: S51 (13)

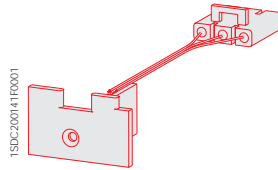

### 4b) Bell alarm with remote reset command

Allows the local (mechanical accessory supplied as standard) and remote signaling (electrical by means of changeover switch) that the circuit breaker is open following operation of the trip units. With this accessory, it is possible to reset the mechanical signaling pushbutton via an electrical coil from remote command, with allows the circuit breaker to be reset.

Available reset coils
24-30 V AC/DC
110-130 V AC/DC
220-240 V AC/DC

Reference figure in circuit diagrams: S51 (14)

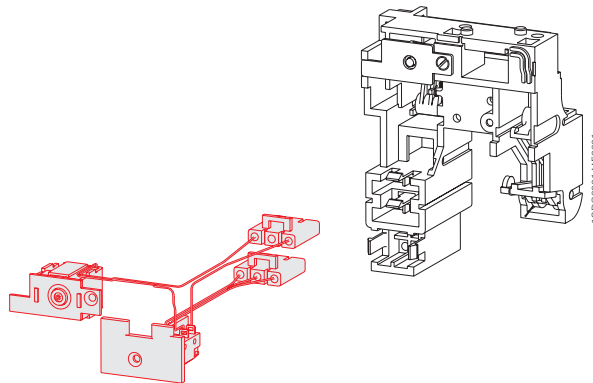



# Auxiliary Contacts

## 5) Auxiliary contacts

Auxiliary contacts are available installed on the circuit breaker, which enable signaling of the circuit breaker status.

Characteristics		
Un	In max	T
125 V DC	0.3 A	10 ms
250 V DC	0.15 A	
Un	In max	cosφ
250 V AC	15 A	0.3

The versions available are as follows:

### 5a-5b) Electrical signaling of circuit breaker open/closed

It is possible to have electrical signaling of the status (open/closed) of the circuit breaker using 4, 10 or 15 auxiliary contacts.

The auxiliary contacts have the following configurations:

- 4 open/closed contacts for PR121 (2 normally open + 2 normally closed)
- 4 open/closed contacts for PR122/PR123 (2 normally open + 2 normally closed + 2 dedicated to trip unit)
- 10 open/closed contacts for PR121 (5 normally open + 5 normally closed)
- 10 open/closed contacts for PR122/PR123 (5 normally open + 5 normally closed + 2 dedicated to trip unit)
- 15 supplementary open/closed contacts for installation outside the circuit breaker.

The standard configuration NO/NC described above can be modified by the user by repositioning the faston connector on the microswitch.

When 10 open/closed contacts for PR122/PR123 are required, the zone discrimination and PR120/K unit are not available.

Reference figures in circuit diagrams: Q/1÷10 (21-22)



1SDC200116F0003

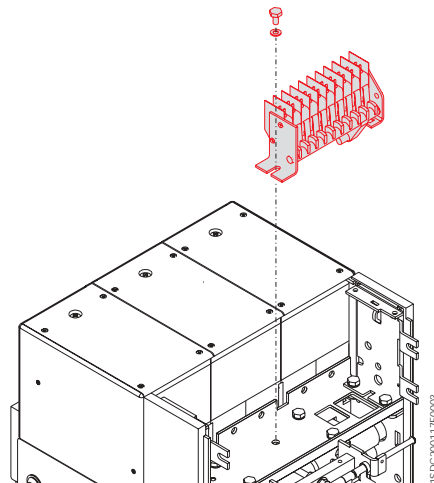

1SDC200117F0003



15DC20011RFO003

### 5c) Electrical signaling of circuit breaker racked-in/test isolated/racked-out

In addition to mechanical signaling of the circuit breaker position, it is also possible to have a remote signal using 5 or 10 auxiliary contacts which are installed into the cradle.

The auxiliary contacts take on the following configurations:

- 5 contacts: 2 contacts for racked-in signal, 2 contacts for racked-out signal, and 1 contact to signal the test isolated position (main power isolated, but sliding contacts connected).
- 10 contacts: 4 contacts for racked-in signal, 4 contacts for racked-out signal, and 2 contacts to signal the test isolated position (main power isolated, but sliding contacts connected).

*Reference figures in circuit diagrams:*

S75I (31-32)

S75T (31-32)

S75E (31-32)

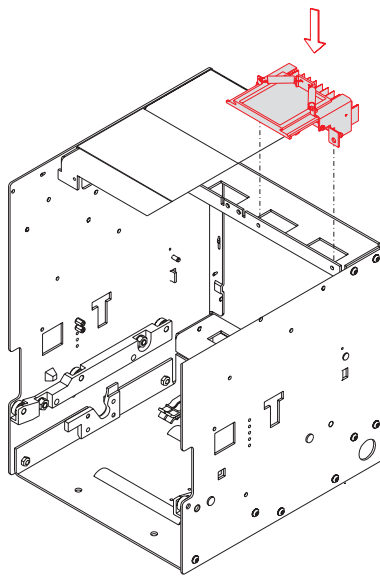

15DC20011RFO003





## Auxiliary Contacts



1SDC200128F0003

### 5d) Contact signaling closing springs charged

A microswitch allows remote signaling of the status of the closing springs (always supplied with the spring charging geared motor).

Reference figure in circuit diagrams: S33 M/2 (11)

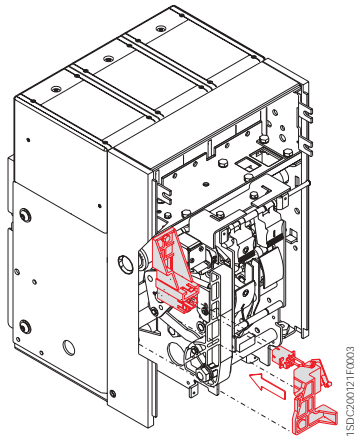

1SDC200128F0003



1SDC200122F0003

### 5e) Contact signaling undervoltage release de-energized (C. Aux YU)

The undervoltage releases can be fitted with a contact for signaling remotely the status of the undervoltage release.

Reference figure in circuit diagrams: (12)

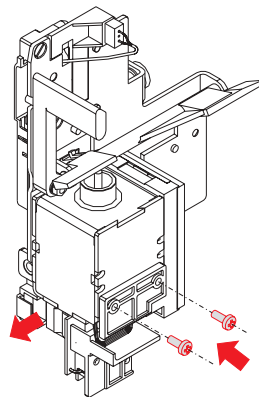

1SDC200128F0003



## Current sensors and operation counters

### 6a) Current sensors for neutral conductor outside circuit breaker



1SDC200124F0003

For three-pole circuit breakers only, this allows protection of the neutral by connection to the trip unit.

Reference figure in circuit diagrams: UI/N (see page 6/8)

### 6b) Homopolar toroid for the main power supply grounding conductor (star center of the transformer)



1SDC200125F0003

PR122 and PR123 electronic trip units can be used in combination with an external toroid located on the conductor, which connects the star center of the MV/LV transformer (homopolar transformer) to ground. In this case, the ground protection is defined as Source Ground Return.

Through to different combinations of its terminals (see chapter 6), the In of the same toroid can be set at 100 A, 250 A, 400 A, 800 A.

Reference figure in circuit diagrams: UI/O (see page 6/8)

### 7) Mechanical operation counter



1SDC200124F0003

This is connected to the operating mechanism by means of a simple lever mechanism, and indicates the number of mechanical operations carried out by the circuit breaker.

The count is shown on the front of the circuit breaker.

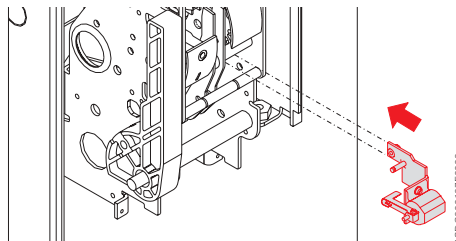

1SDC200127F0003



# Mechanical locks

## 8) Mechanical locks

### 8a-8b) Lock in open position

Several different mechanisms are available which allow the circuit breaker to be locked in the open position.

These devices can be controlled by:

- Key (8a): a special circular lock with different keys (for a single circuit breaker) or the same keys (for several circuit breakers).
- Padlocks (8b): up to 3 padlocks (not supplied):  $\varnothing$  4 mm.
- Provision for Kirk key



1SDC200128F0003



1SDC200129F0003

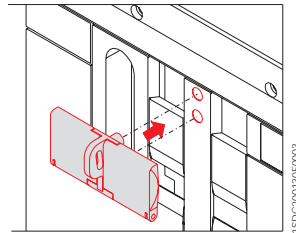

1SDC200130F0003

4

### 8c) Circuit breaker lock in racked-in/test isolated/racked-out position

It is available a key lock (with same of different keys) or a padlock device (up to 3 padlock with a max  $\varnothing$  of 4 mm). It is only available for draw out circuit breakers, to be installed on the moving part.

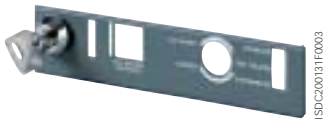

1SDC200131F0003

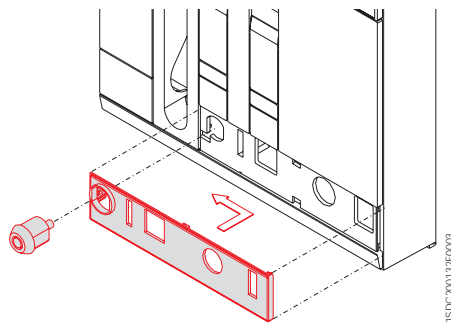

1SDC200132F0003

### 8d) Accessories for lock in test isolated/racked-out position

In addition to the circuit breaker lock in racked-in/test isolated/racked-out position, this allows the circuit breaker to be locked only in the racked-out or test isolated positions.

It is only available for draw out circuit breakers, to be installed on the moving part.



1SDC200133F0003

### 8e) Padlock device for safety shutter

Allows the shutters into the cradle to be padlocked in the closed position.

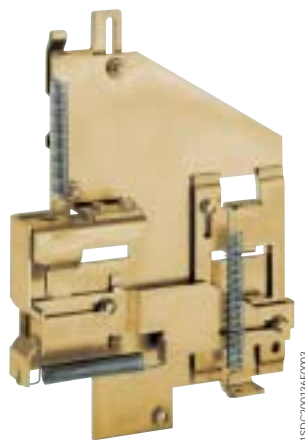
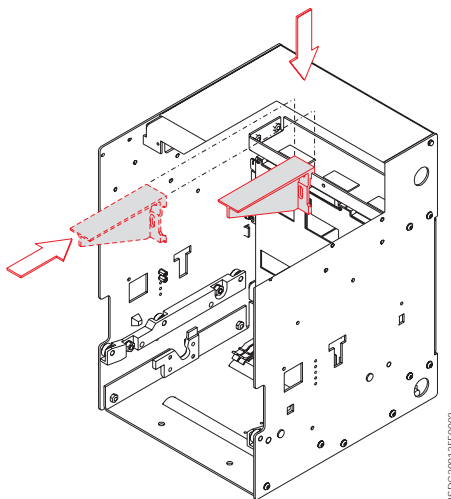

### 8f) Mechanical lock for compartment door

Locks the compartment door from being opened when the circuit breaker is closed (and circuit breaker racked-in for draw out circuit breakers) and prevents the circuit breaker from closing when the compartment door is open.

### 8g) Anti-racking-out device when the springs are charged (FAIL SAFE)

Prevents the moving part of the draw out version circuit breaker from being racked out of the cradle when the springs are charged.

#### Note

This accessory, always supplied with the draw out version circuit breaker, is an alternative to the undervoltage release.



## Transparent protective covers

### 9) Transparent protective covers

#### 9a) Protection for opening and closing pushbuttons

These protections are fitted on the opening and closing pushbuttons, preventing the relative circuit breaker operations unless a special tool is used.



1SDXC200137F0003

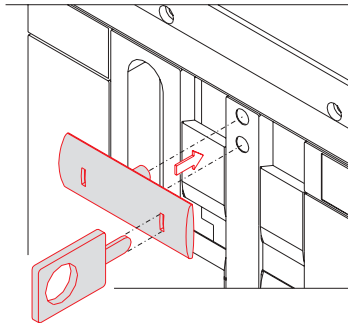

1SDXC200138F0003

4

#### 9b) IP54 door protection (NEMA 3/S/13)

This is a transparent plastic protective cover which completely protects the front panel of the circuit breaker. Mounted on hinges, it is fitted with a key lock.



1SDXC200139F0003

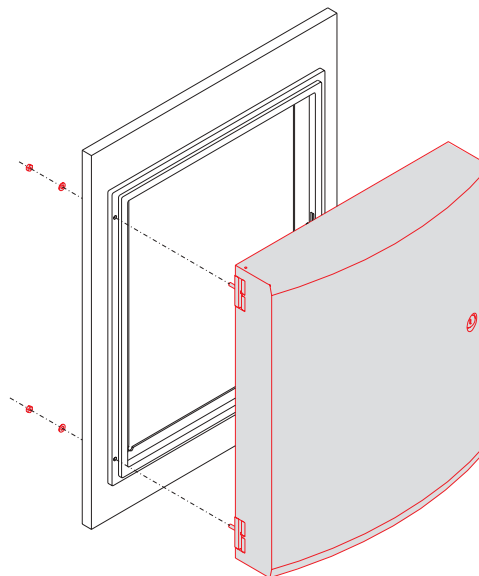

1SDXC200140F0003



# Interlock between circuit breakers

## 10) Mechanical interlock

This mechanism creates a mechanical interlock between two or three circuit breakers (even different models and in any fixed/draw out version) using flexible cables. The electrical diagram for electrical switching by means of a relay (to be provided by the customer) is supplied with the mechanical interlock. The circuit breakers can be installed vertically or horizontally.



Four types of mechanical interlocks are available:

<b>Type A:</b> between 2 circuit breakers (power supply + emergency power supply)
<b>Type B:</b> between 3 circuit breakers (2 power supplies + emergency power supply)
<b>Type C:</b> between 3 circuit breakers (2 power supplies + bus-tie)
<b>Type D:</b> between 3 circuit breakers (3 power supplies/one single closed circuit breaker)

**Note**

See the chapters "Overall dimensions" and "Circuit diagrams" for information about dimensions (fixed and draw out versions) and settings.

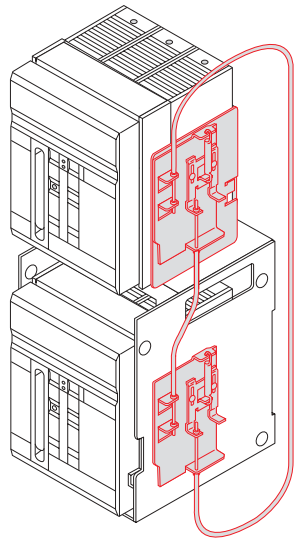

Vertical interlock

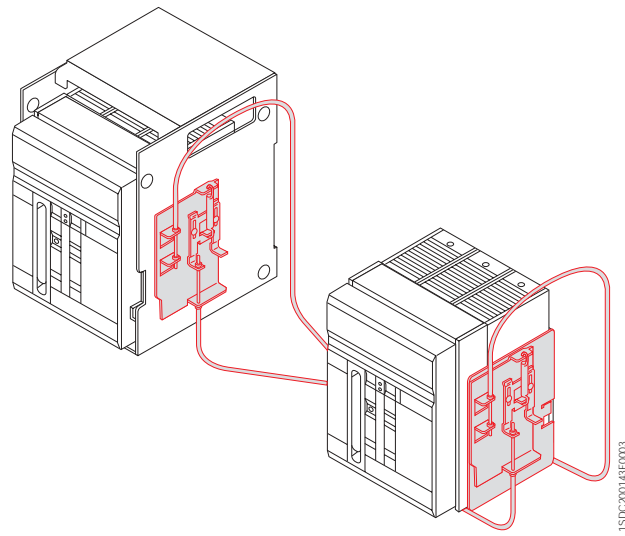

Horizontal interlock



# Interlock between circuit breakers

The possible mechanical interlocks are shown below, depending on whether 2 or 3 circuit breakers (any model in any version) are used in the switching system.

Type of interlock	Typical circuit	Possible interlocks																					
<b>Type A</b> <b>Between two circuit breakers</b> One normal power supply and one emergency power supply	<p>O = Circuit breaker open I = Circuit breaker closed</p>	Circuit breaker 1 can only be closed if 2 is open, and vice-versa. <table border="1"> <thead> <tr> <th>1</th> <th>2</th> </tr> </thead> <tbody> <tr> <td>O</td> <td>O</td> </tr> <tr> <td>I</td> <td>O</td> </tr> <tr> <td>O</td> <td>I</td> </tr> </tbody> </table>	1	2	O	O	I	O	O	I													
1	2																						
O	O																						
I	O																						
O	I																						
<b>Type B</b> <b>Between three circuit breakers</b> Two normal power supplies and one emergency power supply.	<p>O = Circuit breaker open I = Circuit breaker closed</p>	Circuit breakers 1 and 3 can only be closed if 2 is open. Circuit breaker 2 can only be closed if 1 and 3 are open. <table border="1"> <thead> <tr> <th>1</th> <th>2</th> <th>3</th> </tr> </thead> <tbody> <tr> <td>O</td> <td>O</td> <td>O</td> </tr> <tr> <td>I</td> <td>O</td> <td>O</td> </tr> <tr> <td>O</td> <td>O</td> <td>I</td> </tr> <tr> <td>I</td> <td>O</td> <td>I</td> </tr> <tr> <td>O</td> <td>I</td> <td>O</td> </tr> </tbody> </table>	1	2	3	O	O	O	I	O	O	O	O	I	I	O	I	O	I	O			
1	2	3																					
O	O	O																					
I	O	O																					
O	O	I																					
I	O	I																					
O	I	O																					
<b>Type C</b> <b>Between three circuit breakers</b> The two half-busbars can be supplied by a single transformer (bus-tie closed) or by both at the same time (bus-tie open)	<p>O = Circuit breaker open I = Circuit breaker closed</p>	One or two circuit breakers out of three can be closed at the same time. <table border="1"> <thead> <tr> <th>1</th> <th>2</th> <th>3</th> </tr> </thead> <tbody> <tr> <td>O</td> <td>O</td> <td>O</td> </tr> <tr> <td>I</td> <td>O</td> <td>O</td> </tr> <tr> <td>O</td> <td>I</td> <td>O</td> </tr> <tr> <td>O</td> <td>O</td> <td>I</td> </tr> <tr> <td>I</td> <td>I</td> <td>I</td> </tr> <tr> <td>I</td> <td>O</td> <td>I</td> </tr> </tbody> </table>	1	2	3	O	O	O	I	O	O	O	I	O	O	O	I	I	I	I	I	O	I
1	2	3																					
O	O	O																					
I	O	O																					
O	I	O																					
O	O	I																					
I	I	I																					
I	O	I																					
<b>Type D</b> <b>Between three circuit breakers</b> Three power supplies (generators or transformers) on the same busbar, so parallel operation is not allowed	<p>O = Circuit breaker open I = Circuit breaker closed</p>	Only one of three circuit breakers can be closed. <table border="1"> <thead> <tr> <th>1</th> <th>2</th> <th>3</th> </tr> </thead> <tbody> <tr> <td>O</td> <td>O</td> <td>O</td> </tr> <tr> <td>I</td> <td>O</td> <td>O</td> </tr> <tr> <td>O</td> <td>I</td> <td>O</td> </tr> <tr> <td>O</td> <td>O</td> <td>I</td> </tr> </tbody> </table>	1	2	3	O	O	O	I	O	O	O	I	O	O	O	I						
1	2	3																					
O	O	O																					
I	O	O																					
O	I	O																					
O	O	I																					

4

---

---

The emergency power supply is usually installed to take over from the normal power supply in two instances:

- to supply safety services for people (e.g., hospital installations);
- to supply parts of installations which are essential for requirements other than safety (e.g., continuous-cycle industrial plants).

The range of accessories for Emax circuit breakers includes solutions for a wide variety of different plant engineering requirements.

See the specific regulations regarding protections against overcurrents, direct and indirect contacts, and provisions to improve the reliability and safety of emergency circuits.

Switching from the normal to the emergency power supply can be carried out manually (locally or by remote control) or automatically.

To this end, the circuit breakers used for switching must be fitted with the accessories required to allow electric remote control and to provide the electrical and mechanical interlocks required by the switching logic.

These include:

- the shunt trip
- the closing coil
- the motor control
- the auxiliary contacts.

Switching can be automated by means of special electronic-control, to be installed by the customer (diagrams provided by ABB).





## Controller for Automatic Transfer Switch - ATS010 (IEC only)

### 11) Controller for Automatic Transfer Switch - ATS010 (IEC only)

The ATS010 controller is the new network-unit switching device offered by ABB. It is based on microprocessor technology in compliance with the major electromagnetic compatibility and environmental standards (EN 50178, EN 50081-2, EN 50082-2, IEC 68-2-1, IEC 68-2-2, IEC 68-2-3).

The device is able to manage the entire switching procedure between the normal line and emergency line circuit breakers automatically, allowing great flexibility of settings.

In case of fault in the normal line voltage, in accordance with the delays set, the normal line circuit breaker is opened, the generator started and the emergency line circuit breaker closed. Similarly, when the normal line returns to range, the reverse switching procedure is automatically controlled.

It is especially suited for use in all emergency power supply systems requiring a solution that is ready to install, easy to use and reliable.

Some of the main applications include: power supply for UPS (Uninterrupted Power Supply) units, operating theatres and primary hospital services, emergency power supply for civilian buildings, airports, hotels, data banks and telecommunication systems, and power supply of industrial lines for continuous processes.

The switching system consists of the ATS010 unit connected to two motor-driven and mechanically interlocked circuit breakers. Any of the circuit breakers in the Emax series can be used.

The built-in main sensor of the ATS010 device makes it possible to detect faults in the main voltage. The three inputs can be directly connected to the three phases of the normal power supply line for networks with rated voltage up to 500V AC. Networks with a higher voltage require the insertion of potential transformers (PT), setting a rated voltage for the device that matches their secondary voltage (typically 100V).

Two change-over contacts for each circuit breaker allow direct connection to the shunt trip and closing coils. The circuit breaker connection is completed by wiring the status contacts: Open/Closed, Relay tripped, Racked-in (for draw out/plug-in circuit breakers).

For this reason, apart from the mechanical interlock accessories, the following are provided on each circuit breaker connected to the ATS010 unit:

- spring charging motor,
- opening and closing coil,
- open/closed contact,
- racked-in contact (for draw out versions),
- signal and mechanical lock for protection relay tripped.

The ATS010 device is designed to ensure extremely high reliability for the system it controls. It contains various safety systems intrinsically related to software and hardware operation.

For software safety, a special logic prevents undesired operations, while a constantly operative watchdog system points out any microprocessor malfunctions by means of a LED on the front of the device.

Hardware safety allows integration of an electrical interlock by means of a power relay, making the use of an external electrical interlocking system superfluous. The manual selector on the front of the device can also control the entire switching procedure, even in the event of a microprocessor fault, by working electromechanically on the control relays.



1SD2C00148F0003

General specifications	
Rated supply voltage (galvanically insulated from ground)	24V DC $\pm$ 20% 48V DC $\pm$ 10% (maximum ripple $\pm$ 5%)
Maximum absorbed power	5W at 24V DC 10W at 48V DC
Rated power (mains present and circuit breakers not controlled)	1.8W at 24V DC 4.5W at 48V DC
Operating temperature	-25 °C...+70 °C
Maximum humidity	90% without condensation
Storage temperature	-25 °C...+80 °C
Degree of protection	IP54 (front panel)
Dimensions [mm]	144 x 144 x 85
Weight [kg]	0.8

Setting range for thresholds and times		
Minimum voltage	Un Min	-5%...-30% Un
Maximum voltage	Un Max	+5%...+30% Un
Fixed frequency thresholds		10%...+10% fn
t1: opening delay of the normal line circuit breaker due to network error (CB-N)		0...32 s
t2: generator start-up delay due to network error		0...32 s
t3: stopping delay of the generator		0...254 s
t4: switching delay due to network stop		0...254 s
t5: closing delay of the emergency line circuit breaker after detecting the generator voltage (CB-E)		0...32 s

Rated voltage settings available	100, 115, 120, 208, 220, 230, 240, 277, 347, 380, 400, 415, 440, 480, 500 V
----------------------------------	---

**Operating sequence**

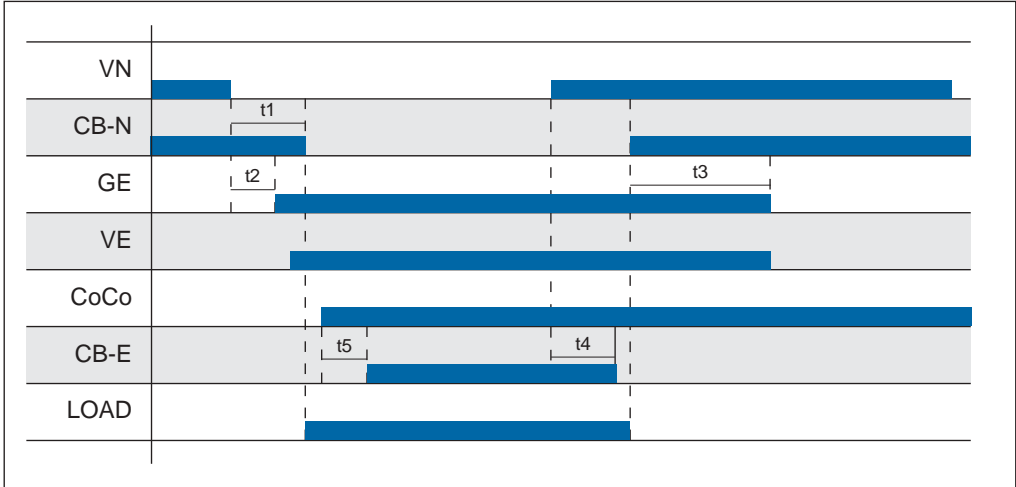

**Caption**  
 VN Main voltage  
 CB-N Normal line circuit breaker closed  
 GE Generator  
 VE Emergency line voltage  
 CoCo Enable switching to emergency line  
 CB-E Emergency line circuit breaker closed  
 LOAD Disconnection of lower priority connected loads



# Controller for Automatic Transfer Switch - ATS010 (IEC only)

## Front panel

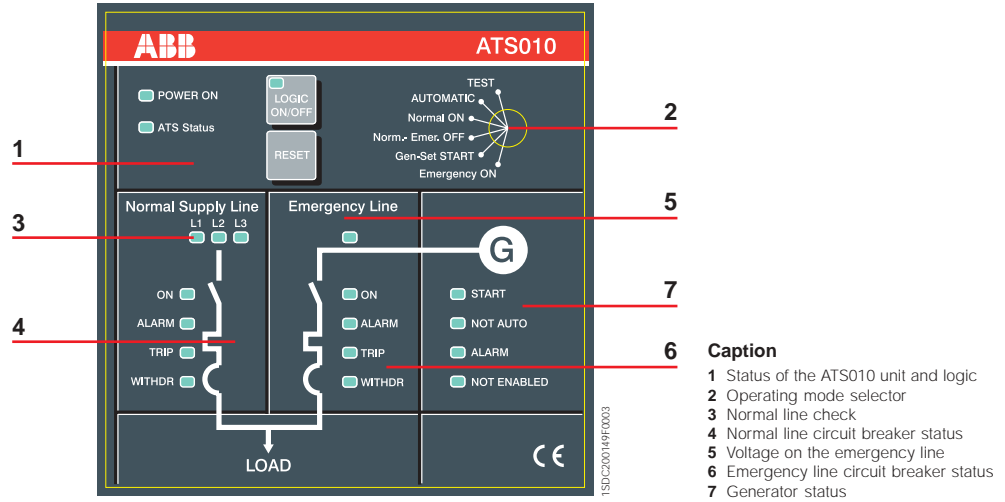

**Caption**

- 1 Status of the ATS010 unit and logic
- 2 Operating mode selector
- 3 Normal line check
- 4 Normal line circuit breaker status
- 5 Voltage on the emergency line
- 6 Emergency line circuit breaker status
- 7 Generator status

4

## Side panel settings

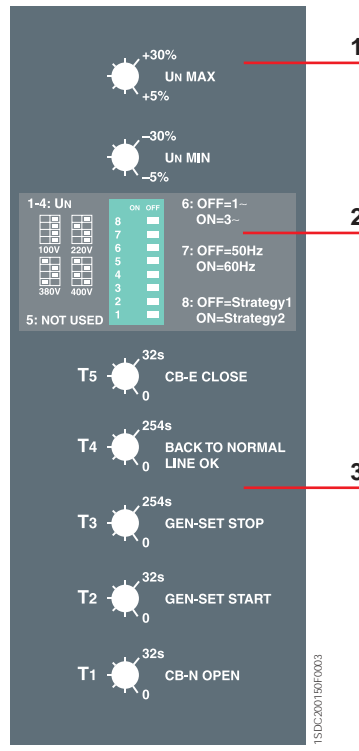

**Caption**

- 1 Selectors to set the under- and overvoltage thresholds
- 2 Dip-switches to set:
  - rated voltage
  - normal single-phase or three-phase line
  - mains frequency
  - switching strategy
- 3 Switching delay time settings for t1... t5



---

## Spare parts

---

---

### Spare parts

The following spare parts are available:

- front shields and escutcheon plate
- opening solenoid for PR121, PR122 and PR123 trip units
- arcing chamber
- closing springs
- plier isolation contact for the cradle of the draw out circuit breaker
- grounding sliding contact (for draw out version)
- shutters for cradle
- complete pole
- operating mechanism
- connection cables between releases and current transformers
- transparent protective cover for releases
- PR130/B power supply unit
- toolbox
- battery for PR130/B power supply unit
- front escutcheon plate for Ronis key lock

For further details, request a copy of the ABB spare parts catalog.



# Emax

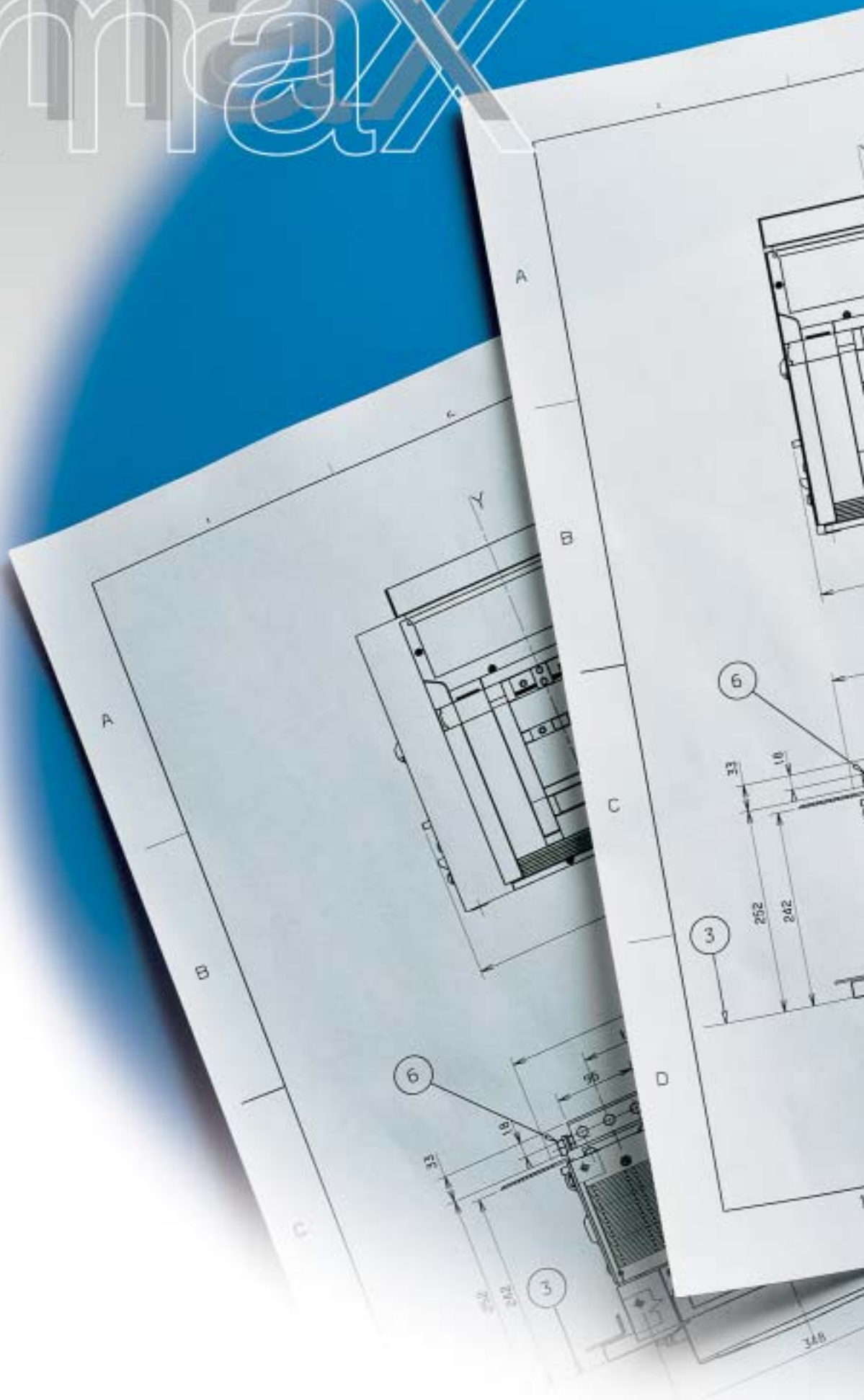



# Overall dimensions

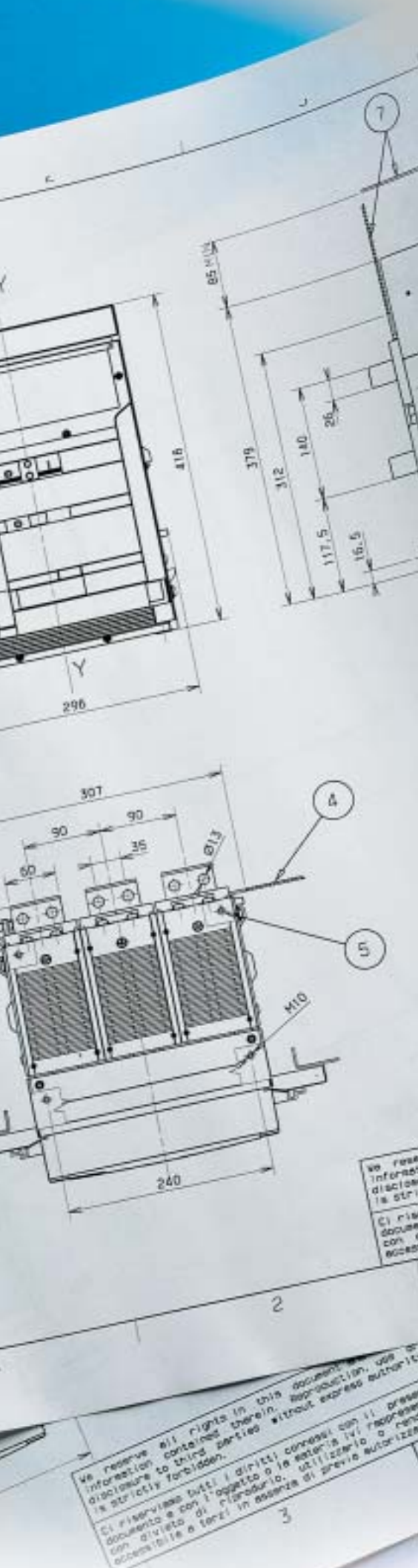

## Contents

Fixed circuit breaker .....	5/2
Draw out circuit breaker .....	5/7
Installation in switchboard .....	5/15
Mechanical interlock .....	5/16
Circuit breaker accessories .....	5/18

# Overall dimensions

## Fixed circuit breaker

### Basic version with horizontal rear terminals

[mm/in]

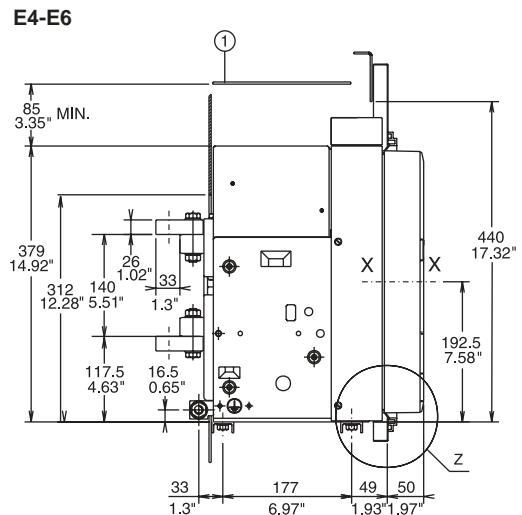
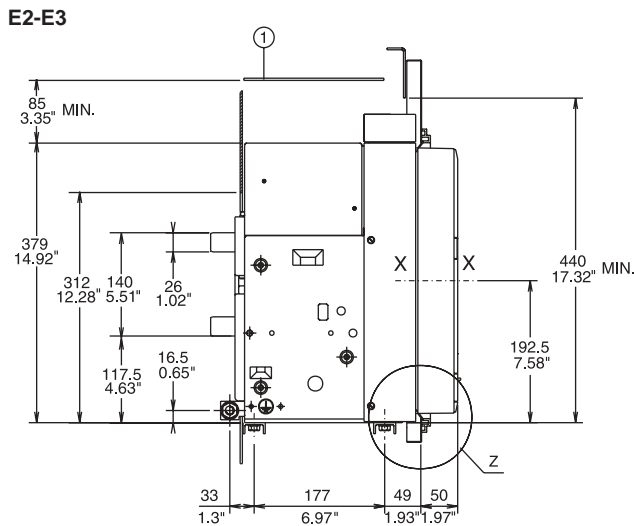
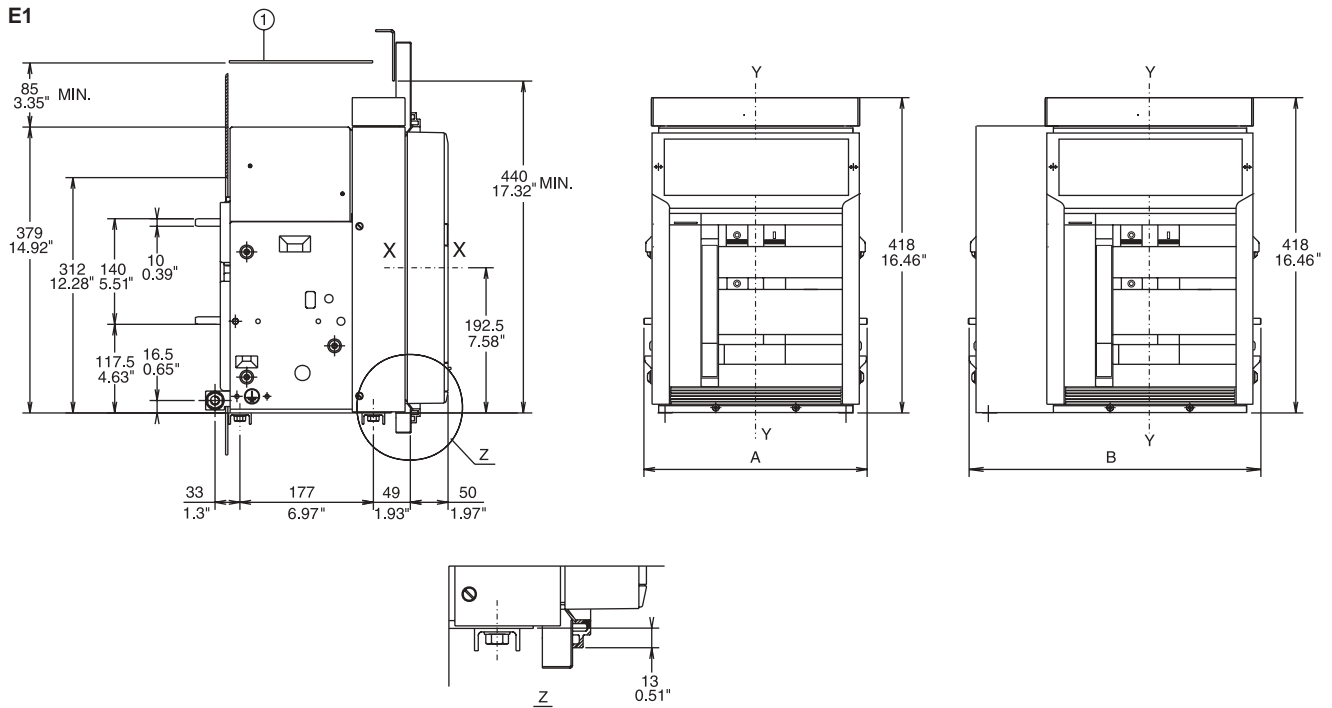

1SD/C200152/F0003

### Caption

① Insulating wall or insulated metal wall

	A 3 Poles	B 4 Poles
<b>E1-A</b>	296/11.65"	386/15.2"
<b>E2-A</b>	296/11.65"	386/15.2"
<b>E3-A</b>	404/15.91"	530/20.87"
<b>E4-A</b>	566/22.28"	656/25.83"
<b>E6-A</b>	782/30.79"	908/35.75"



E1 3 poles / E2 3 poles

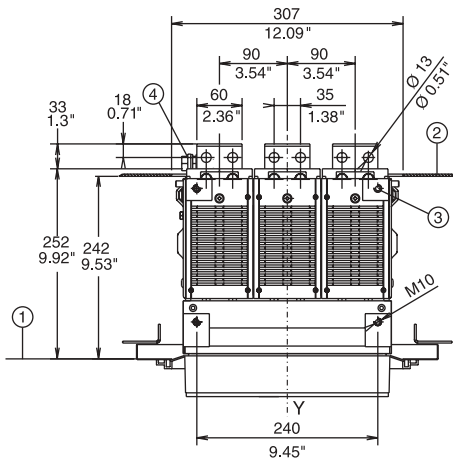

E1 4 poles / E2 4 poles

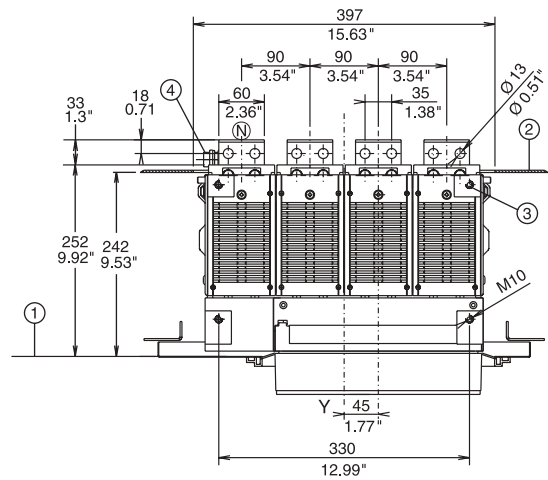

E3 3 poles

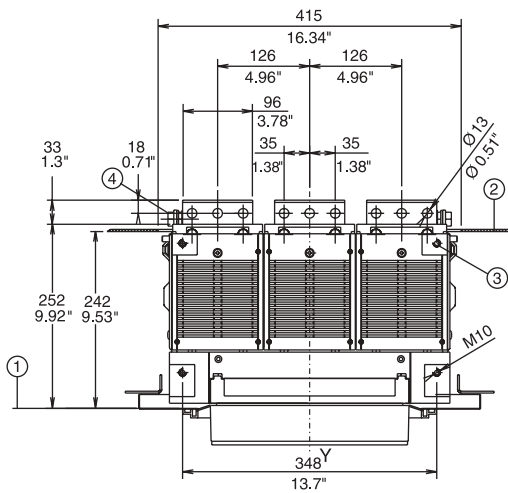

E3 4 poles

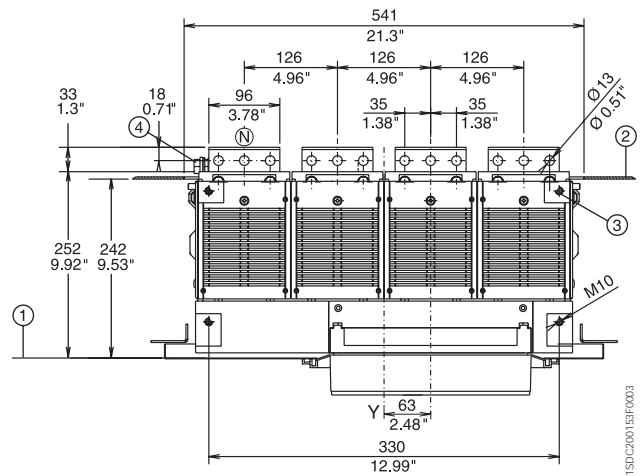

**Caption**

- ① Inside edge of compartment door
- ② Segregation (when provided)
- ③ M10 mounting holes for circuit breaker (included in the supply)
- ④ 1x M12 screw for earthing (included in the supply)

# Overall dimensions

## Fixed circuit breaker

[mm/in]

### Basic version with horizontal rear terminals

E4 3 poles

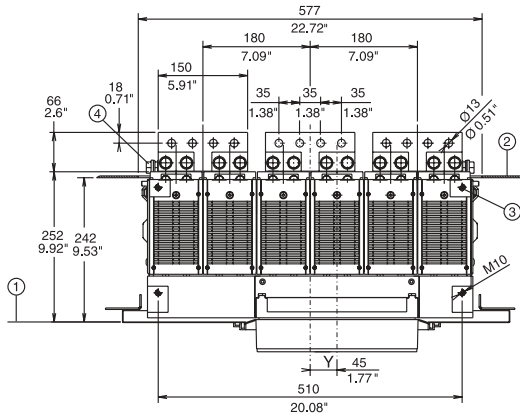

E4 4 poles

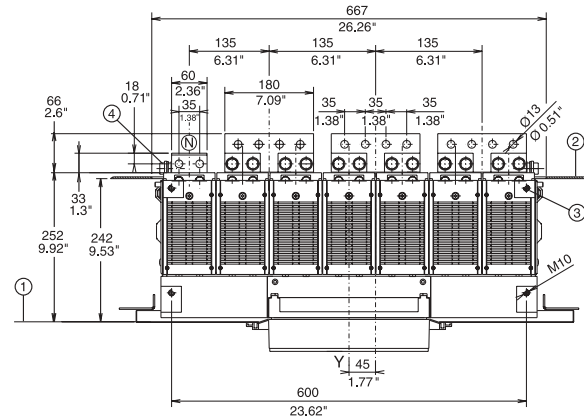

E6 3 poles

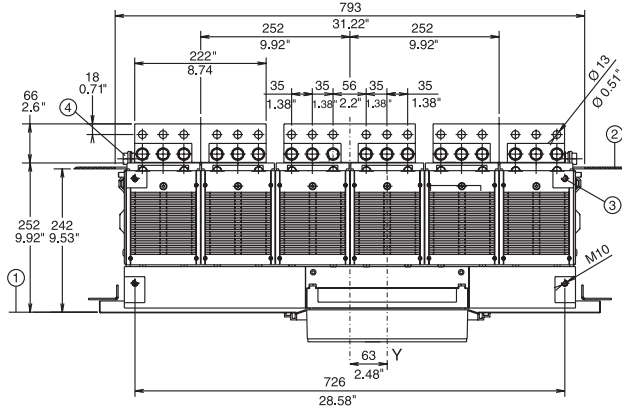

E6 4 poles

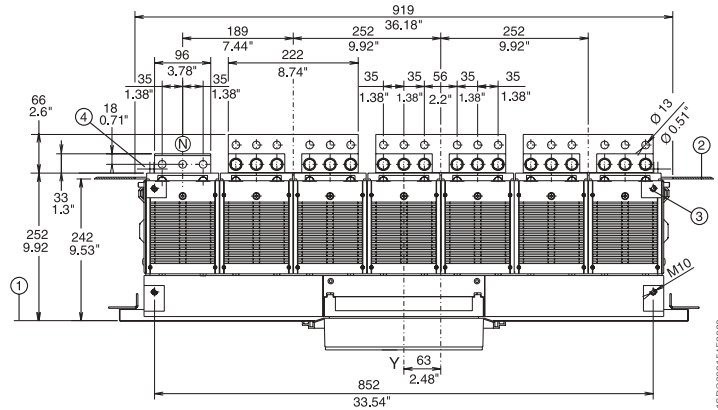

1SD0C00154F0003

### Caption

- ① Inside edge of compartment door
- ② Segregation (when provided)
- ③ M10 mounting holes for circuit breaker (included in the supply)
- ④ 1x M12 screw for earthing (included in the supply)

**Basic version**  
with vertical  
rear terminals

[mm/in]

**E1**

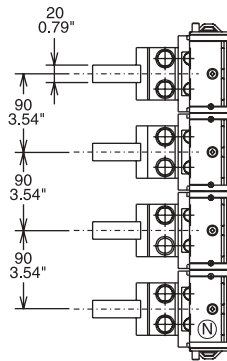

**E2**

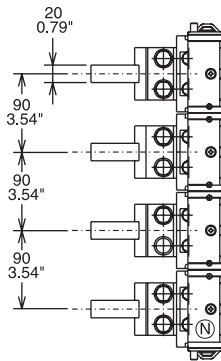

**E3 1200÷2000 A**

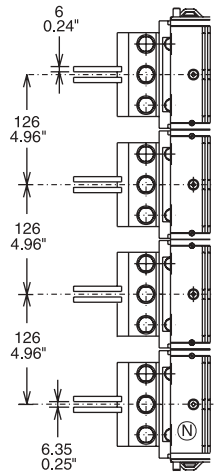

**E1**

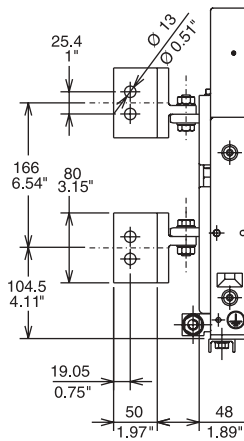

**E2**

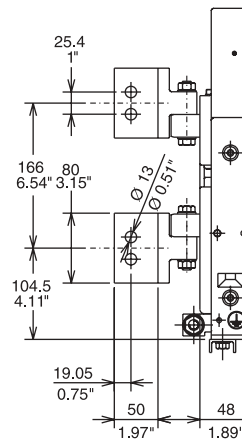

**E3 1200÷2000 A**

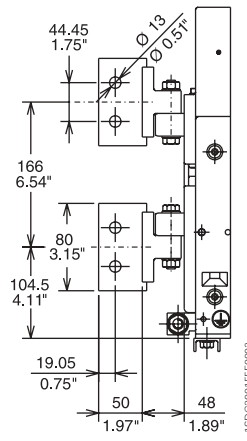

1SD020015BF0003

# Overall dimensions

## Fixed circuit breaker

### Basic version

### with vertical rear terminals

[mm/in]

E3 2500 A

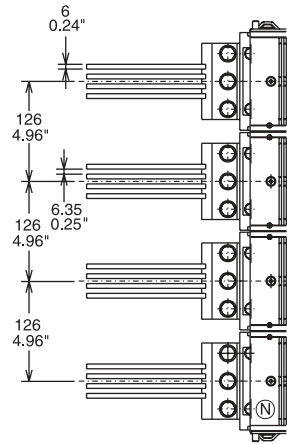

E4

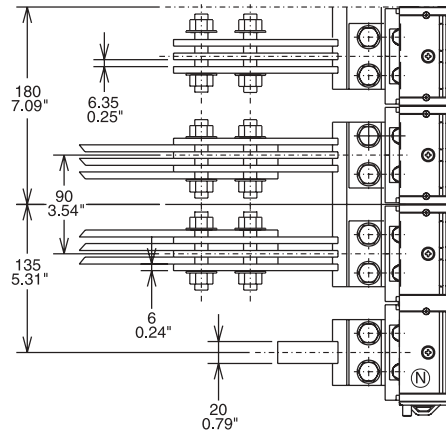

E6

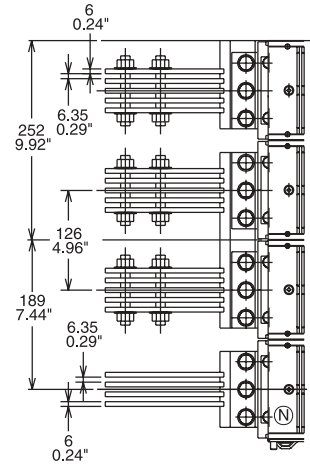

E3 2500 A

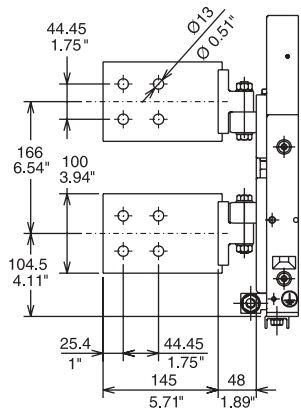

E4

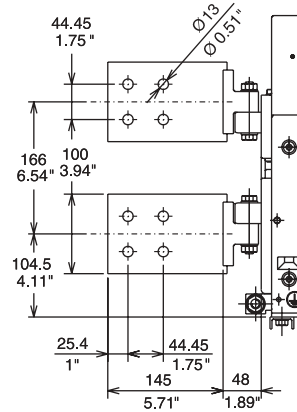

E6

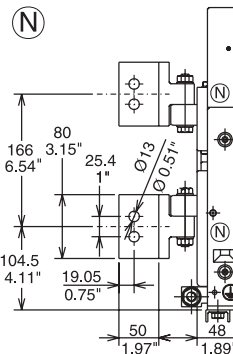
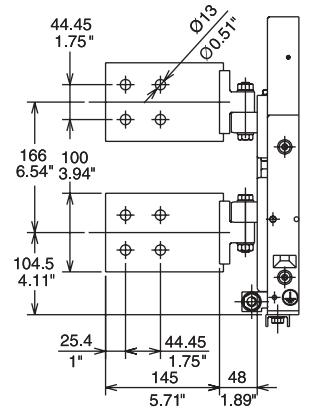

1SD2C00156F0003

5



# Overall dimensions

## Draw out circuit breaker

[mm/in]

### Basic version with horizontal rear terminals

E1

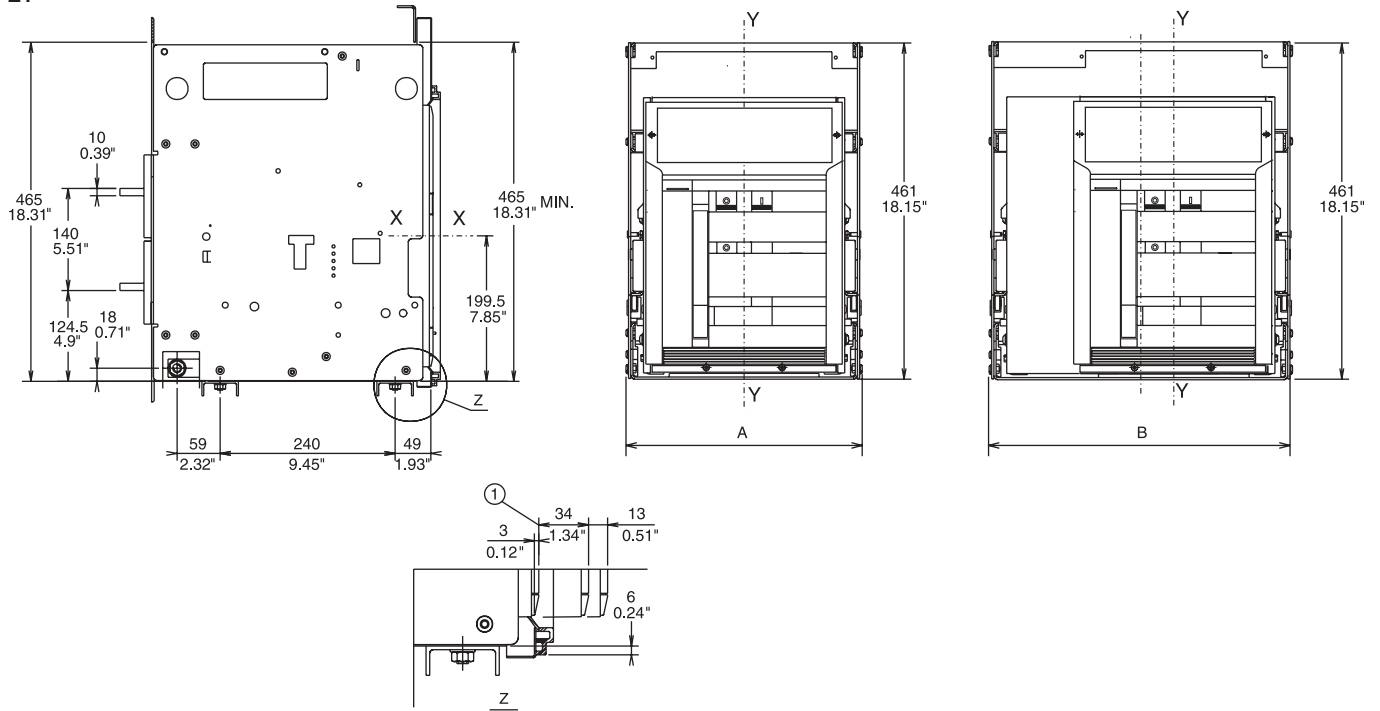

E2-E3-E4-E6

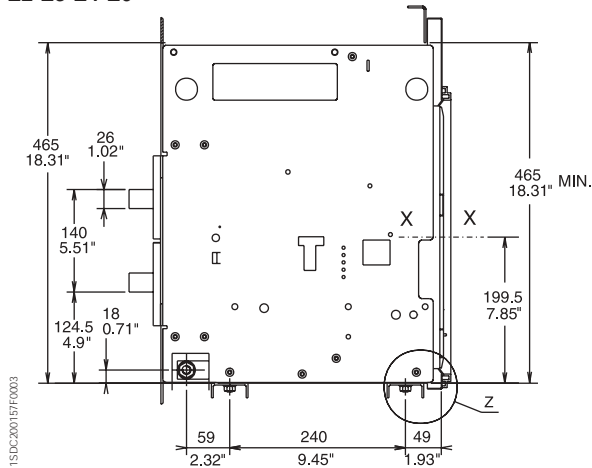

	A 3 Poles	B 4 Poles
E1-A	324/12.76"	414/16.3"
E2-A	324/12.76"	414/16.3"
E3-A	432/17.01"	558/21.97"
E4-A	594/23.39"	684/26.93"
E6-A	810/31.89"	936/36.85"

### Caption

① Distance from connected for testing to isolated

# Overall dimensions

## Draw out circuit breaker

### Basic version with horizontal rear terminals

[mm/in]

E1 3 poles / E2 3 poles

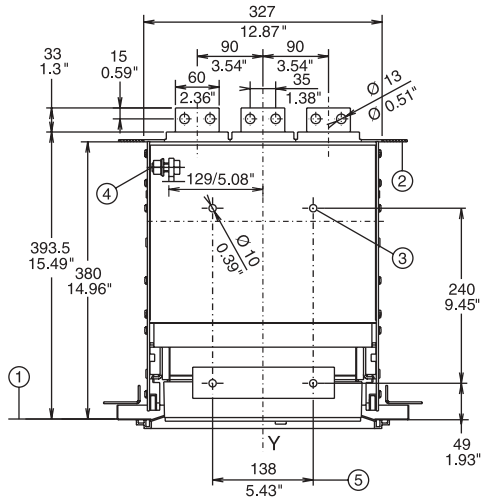

E1 4 poles / E2 4 poles

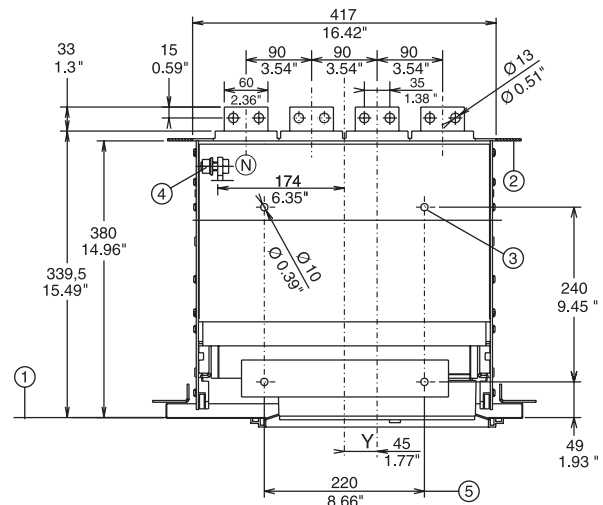

E3 3 poles

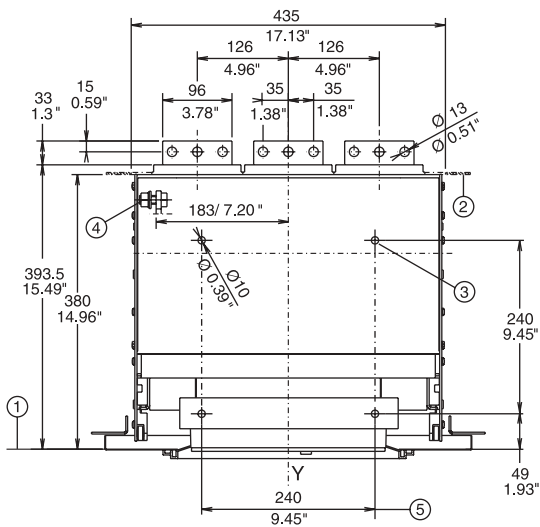

E3 4 poles

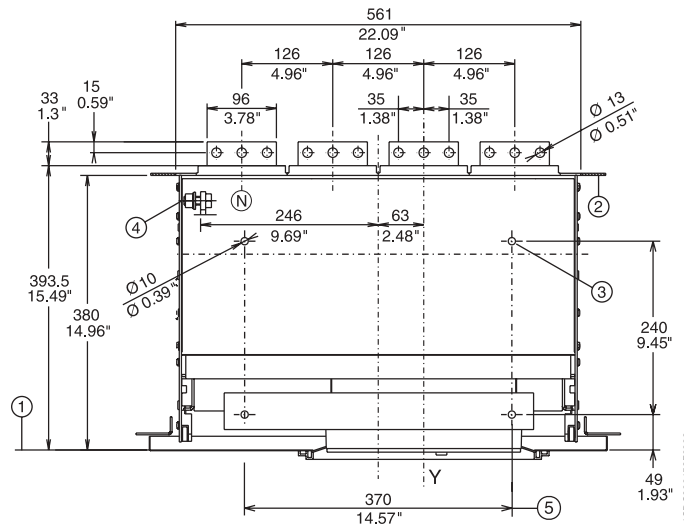

#### Caption

- ① Inside edge of compartment door
- ② Segregation (when provided)
- ③ M8 mounting holes for circuit breaker (included in the supply)
- ④ 1x M12 screws for earthing (included in the supply)
- ⑤ 4 holes for mounting fixed part (standard)

1SD/C2001B1R0003

E4 3 poles

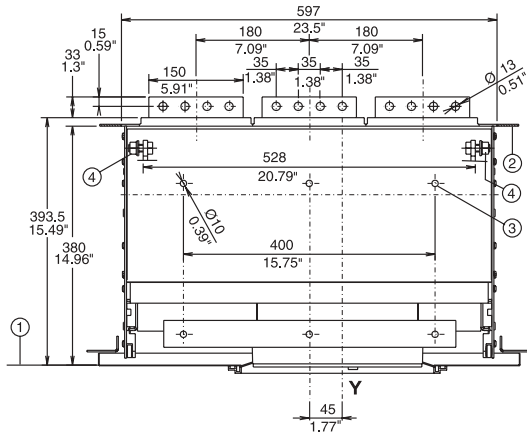

E4 4 poles

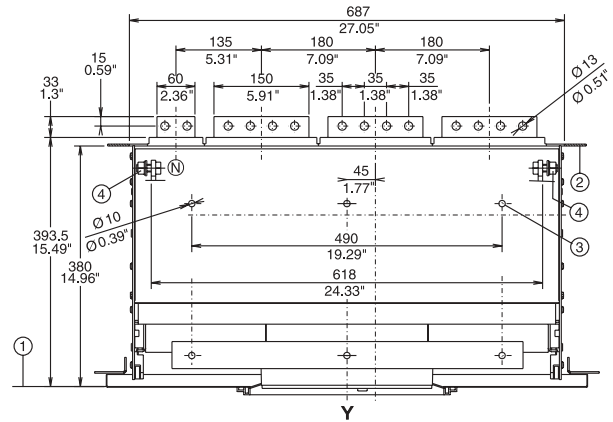

E6 3 poles

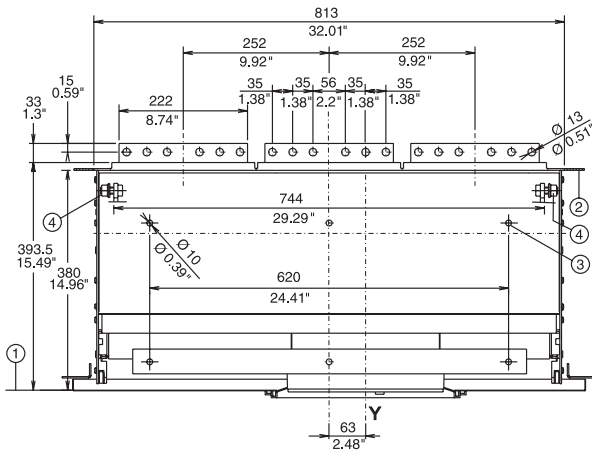

E6 4 poles

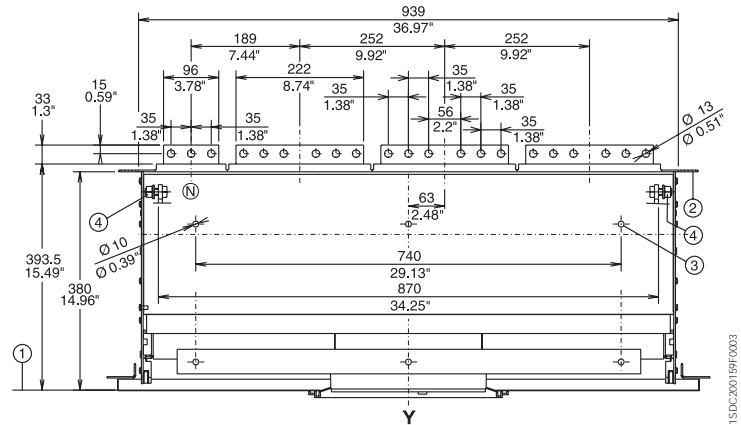

**Caption**

- ① Inside edge of compartment door
- ② Segregation (when provided)
- ③ M8 mounting holes for circuit breaker (included in the supply)
- ④ 1x M12 screw for earthing (included in the supply)

# Overall dimensions

## Draw out circuit breaker

**Basic version**  
with vertical  
rear terminals

[mm/in]

E1 3 poles / E2 3 poles

E1 4 poles / E2 4 poles

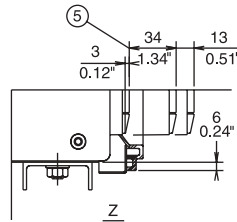
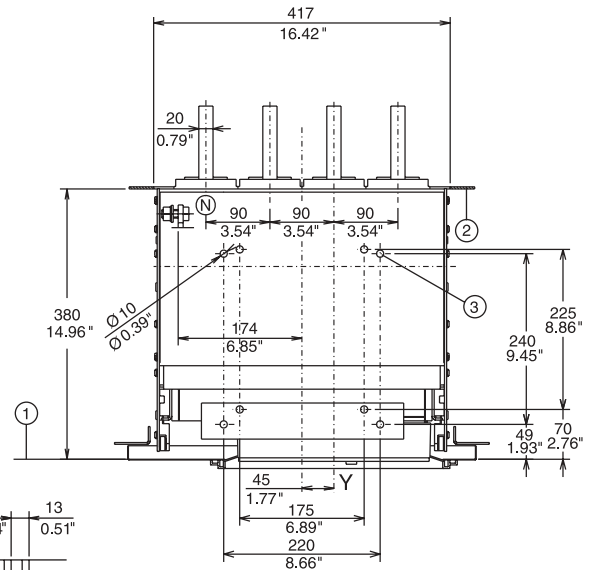
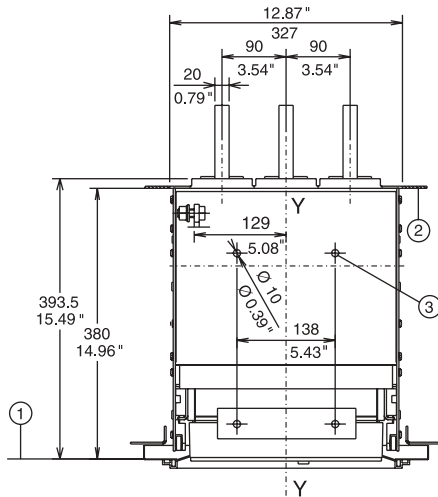

E1-E2

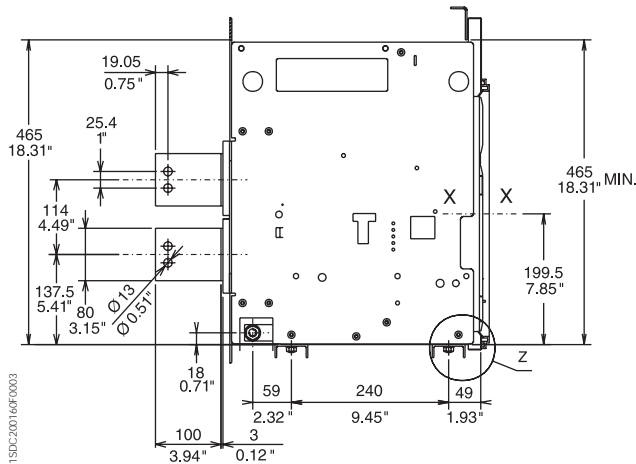

### Caption

- ① Inside edge of compartment door
- ② Segregation (when provided)
- ③ M8 mounting holes for circuit breaker (included in the supply)
- ⑤ Distance from connected for testing to isolated

150C200165F0003



E3 3 poles 1200÷2000 A

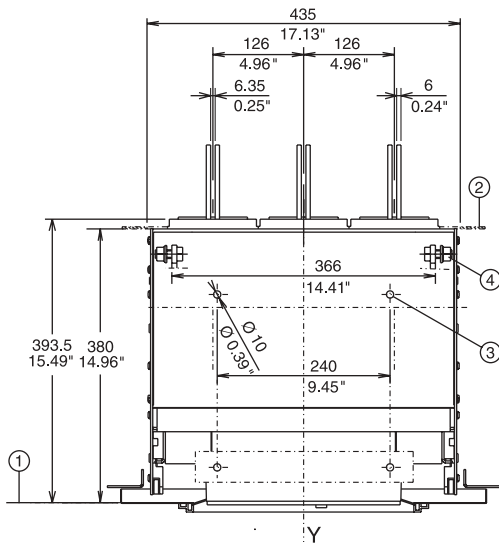

E3 4 poles 1200÷2000 A

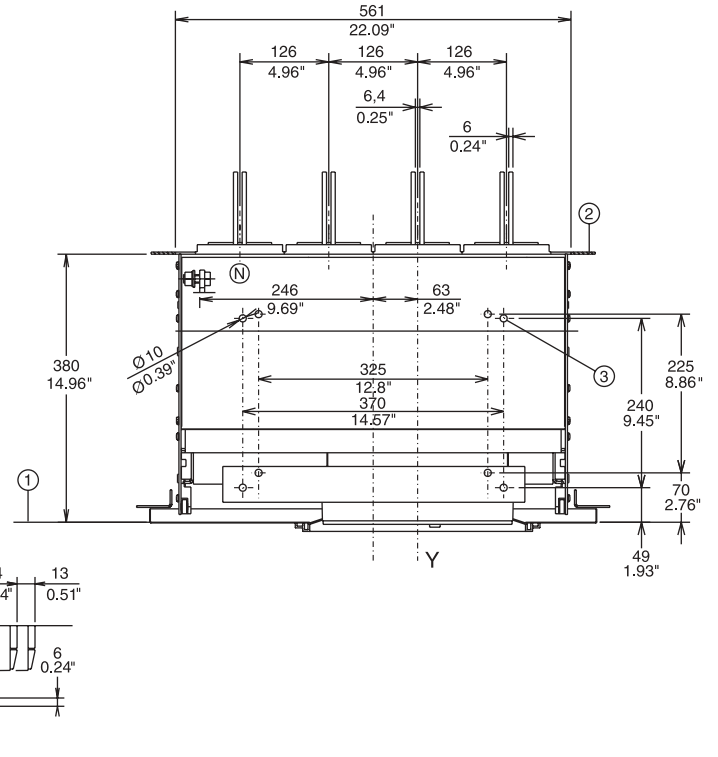

E3 1200÷2000 A

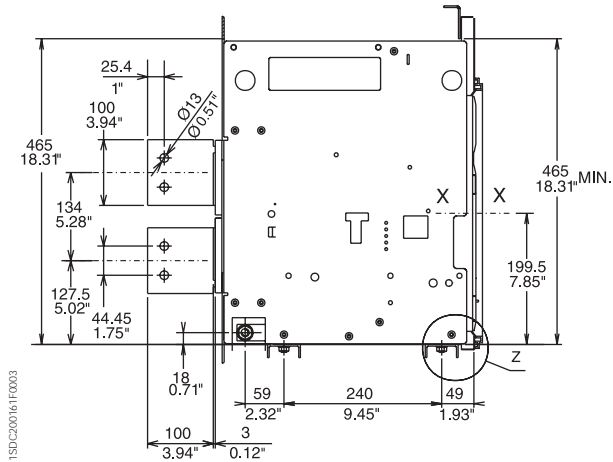

**Caption**

- ① Inside edge of compartment door
- ② Segregation (when provided)
- ③ M8 mounting holes for circuit breaker (included in the supply)
- ④ 2x M12 screws for earthing (included in the supply)
- ⑤ Distance from connected for testing to isolated

1SDC200161F0003

# Overall dimensions

## Draw out circuit breaker

**Basic version**  
with vertical  
rear terminals

[mm/in]

E3 3 poles 2500 A

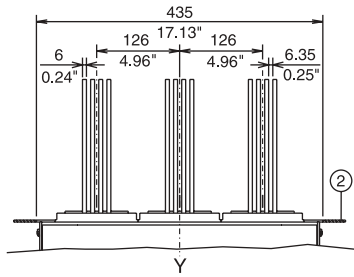

E3 4 poles 2500 A

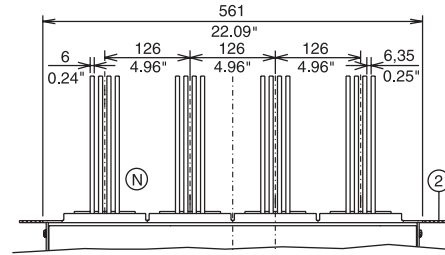

E3 3 poles 3200 A

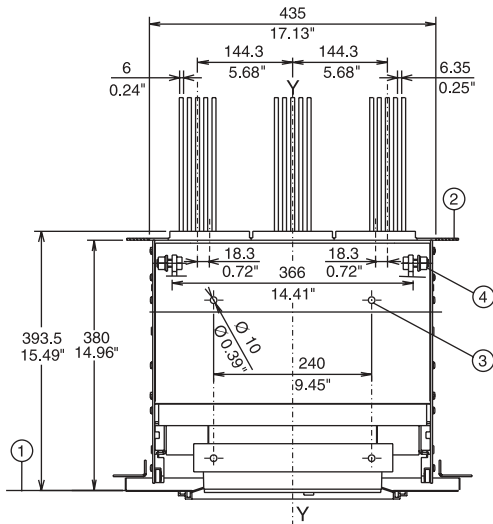

E3 4 poles 3200 A

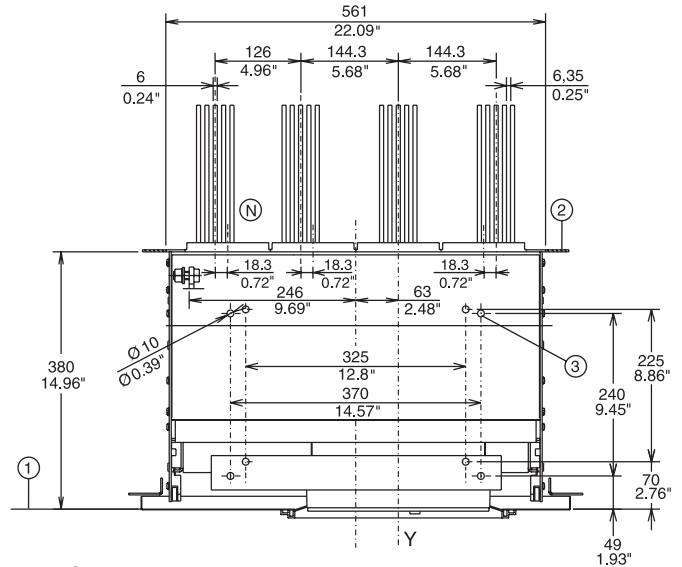

E3 2500 A/3200 A

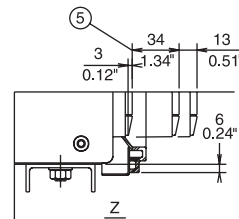
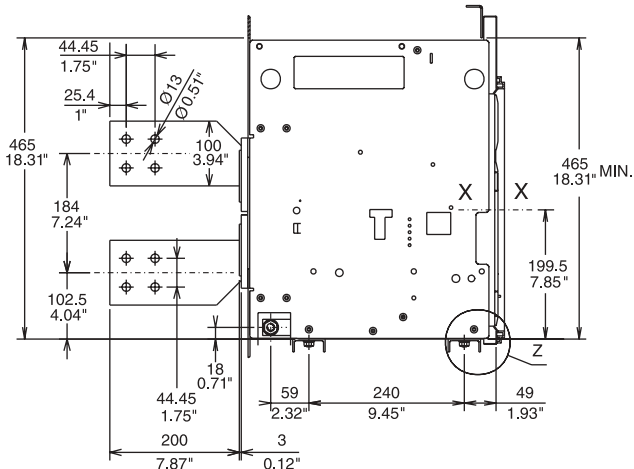

**Caption**

- ① Inside edge of compartment door
- ② Segregation (when provided)
- ③ M8 mounting holes for circuit breaker (included in the supply)
- ④ 2x M12 screws for earthing (included in the supply)
- ⑤ Distance from connected for testing to isolated

5

1SDC200162F0003

E4 3 poles

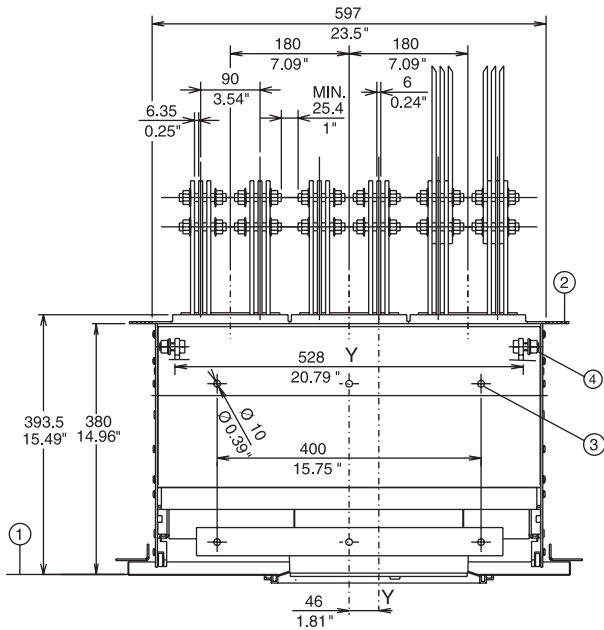

E4 4 poles

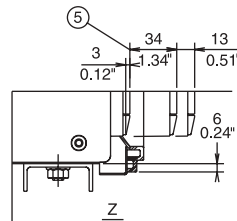
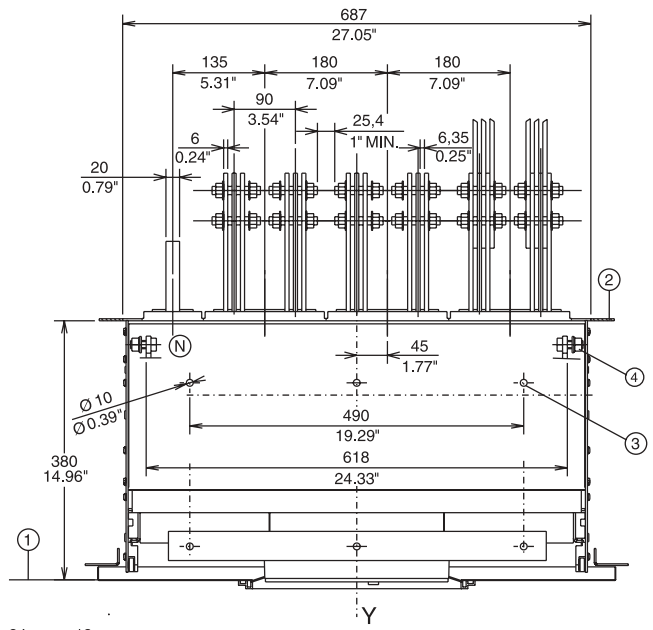

E4

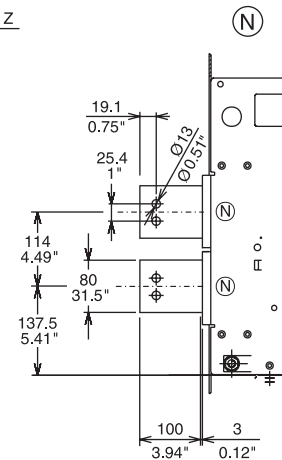
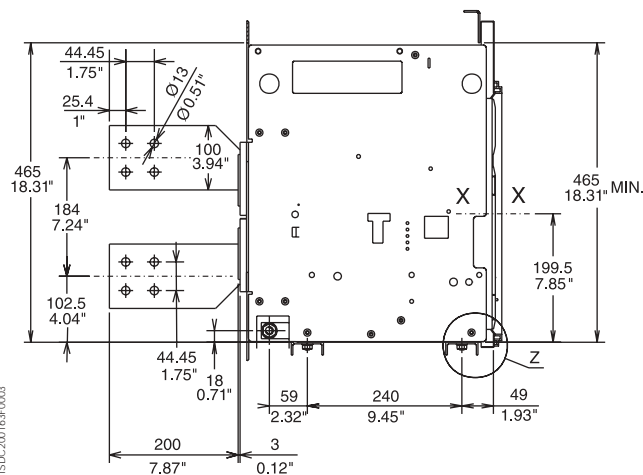

**Caption**

- ① Inside edge of compartment door
- ② Segregation (when provided)
- ③ M8 mounting holes for circuit breaker (included in the supply)
- ④ 2x M12 screws for earthing (included in the supply)
- ⑤ Distance from connected for testing to isolated

1SD2C00163F0003

# Overall dimensions

## Draw out circuit breaker

**Basic version**  
with vertical  
rear terminals

[mm/in]

E6 3 poles

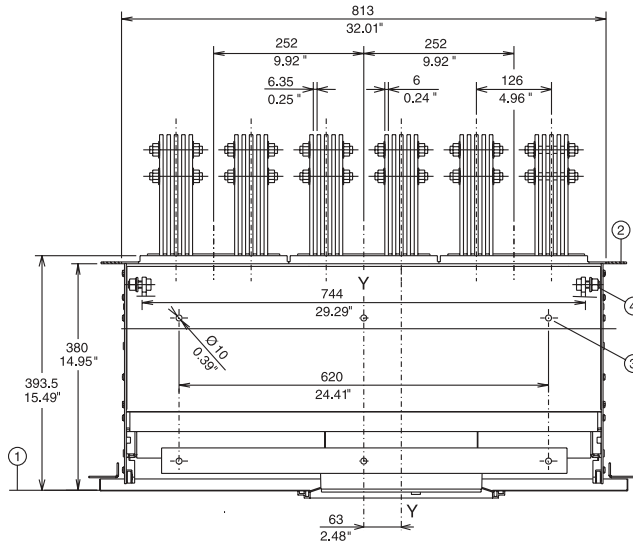

E6 4 poles

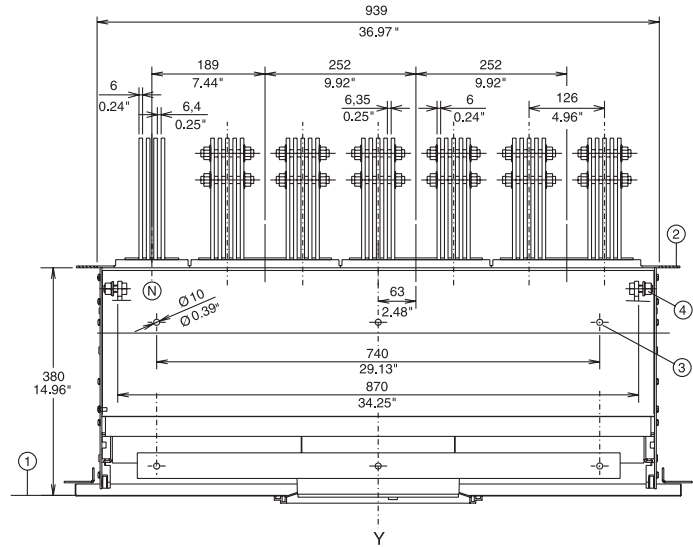

E6

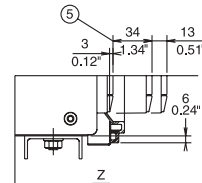
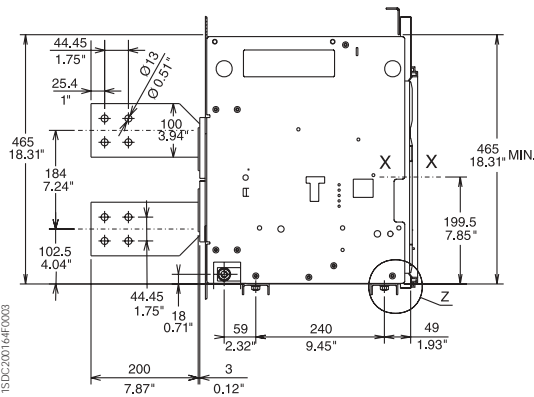

### Caption

- ① Inside edge of compartment door
- ② Segregation (when provided)
- ③ M8 mounting holes for circuit breaker (included in the supply)
- ④ 2x M12 screws for earthing (included in the supply)
- ⑤ Distance from connected for testing to isolated



# Overall dimensions

## Installation in switchboard

[mm/in]

### Dimensions of compartment

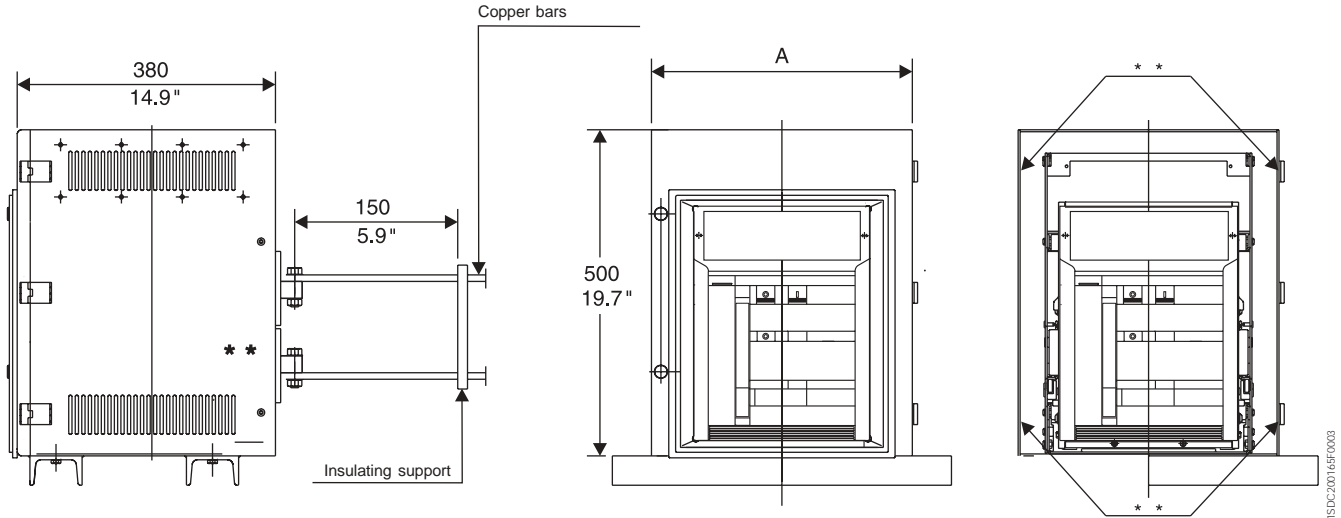

1SDC200164F0003

	A 3 Poles	A 4 Poles
<b>E1-A</b>	400/11.65"	490/19.30"
<b>E2-A</b>	400/15.7"	490/19.30"
<b>E3-A</b>	500/19.7"	630/24.82"
<b>E4-A</b>	700/25.7"	790/30.62"
<b>E6-A</b>	1000/39.3"	1130/44.52"

\*\* Suitable for continuous operation at 100% rating in a minimum cubicle space (see the table), with a ventilation of 48 (12x4) sq. in. side bottom and side top.

Refer to shop drawings for verification.

### Drilling of compartment door

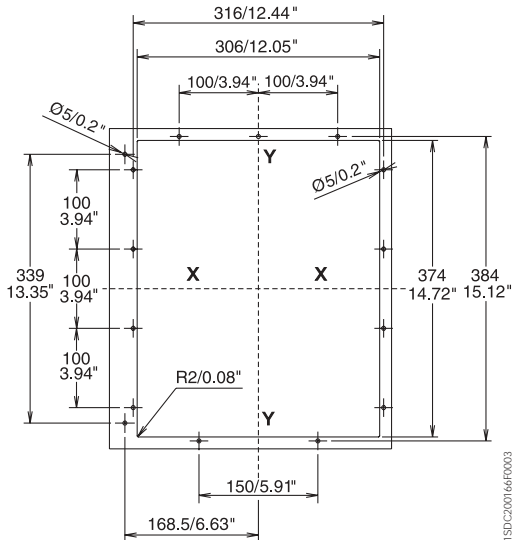

1SDC200164F0003

**Tightening torque for fastening screws Nm 20 - 177 lb/in**  
**Tightening torque for main terminals Nm 70 - 620 lb/in**  
**Tightening torque for earthing screw Nm 70 - 620 lb/in**

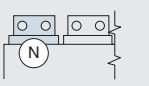
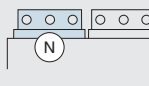
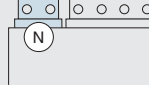
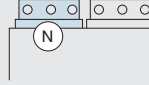
	High strength M12 screw Number per terminal	
	PHASE	NEUTRAL
 <b>E1-E2</b>	2	2
 <b>E3</b>	3	3
 <b>E4</b>	4	2-4
 <b>E6</b>	6	3-6

1SDC200167F0003

# Overall dimensions

## Mechanical interlock

### Interlock assembly

[mm/in]

**Type A**  
Horizontal  
Vertical

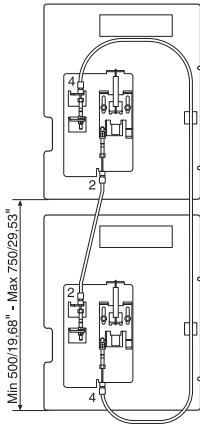

**Type B**  
(emergency interlock below)  
Horizontal Vertical

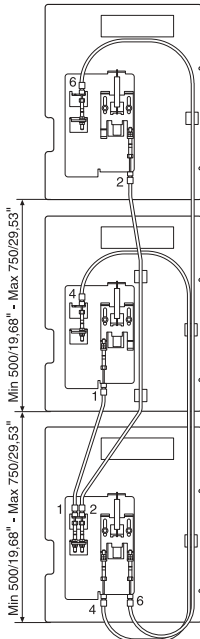

**Type B**  
(emergency interlock in the middle)  
Horizontal Vertical

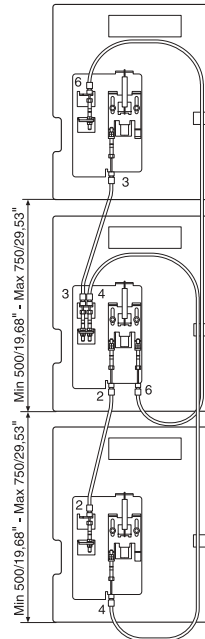

**Type B**  
(emergency interlock above)  
Horizontal Vertical

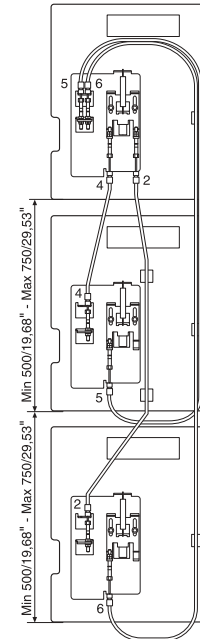

**Type C**  
Horizontal Vertical

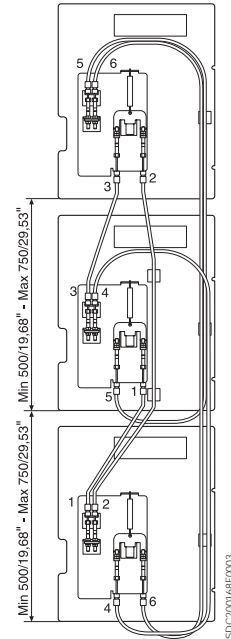

**Type D**  
Horizontal Vertical

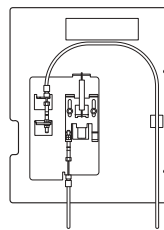
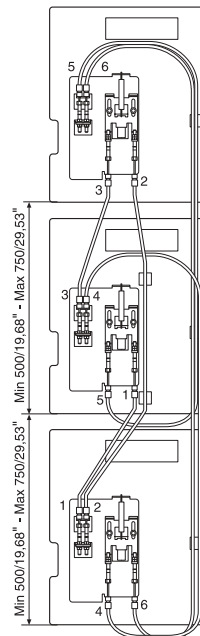

#### Horizontal interlocks

Maximum distance between two interlocks: 1200/47.28 mm from one interlock to the other. The cables pass under the cradles, following the same connection diagram shown for vertical circuit breakers.

#### Notes

When fitting interlocks between two circuit breakers, it is necessary to make suitable holes (through the switchboard) in the mounting surface for fixed circuit breakers or for the cradle of draw out circuit breakers, in order to pass the flexible cables through, respecting the measurements shown in the figures on page 5/17. For vertical interlocks, align the right-hand sides vertically and reduce the bends in the flexible cables to a minimum (minimum radius R. 70 mm / 2.76 in). All the angle values of the bends which the cable passes through added together must not exceed 720°.

1SD/C200168F0003

1SD/C200168F0003

**Through-holes for flexible cables for mechanical interlocks**

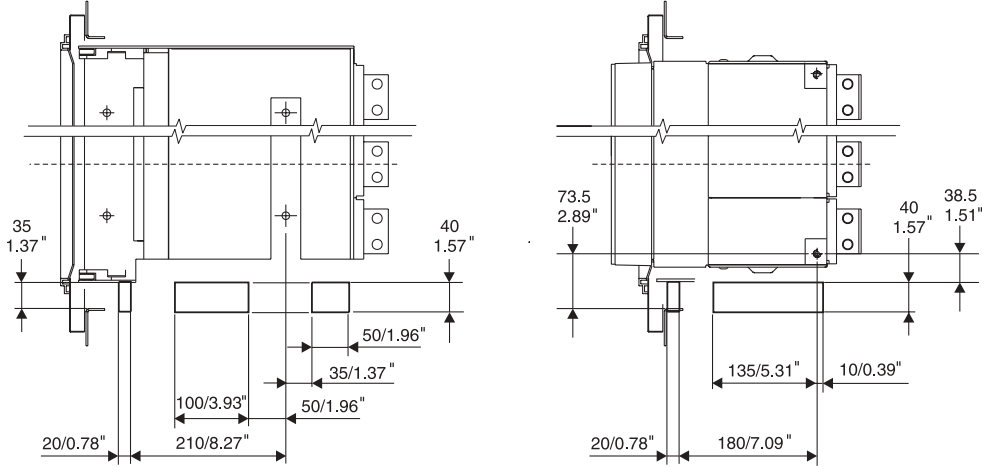

1SDC200170F0003



# Overall dimensions

## Circuit breaker accessories

[mm/in]

### Mechanical compartment door lock

#### Drilling in compartment door

#### Minimum distance between circuit breaker and switchboard wall

Fixed version

Draw out version

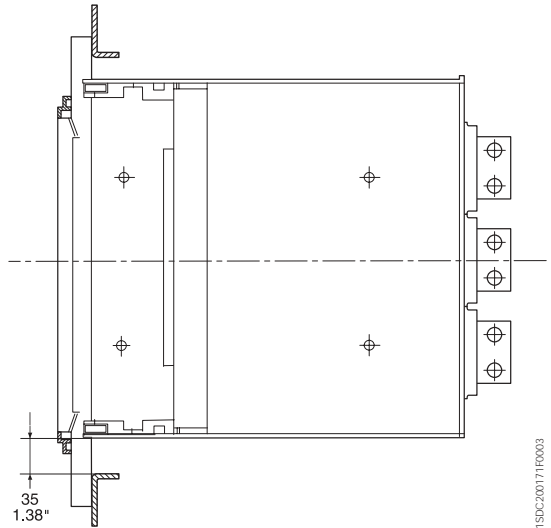
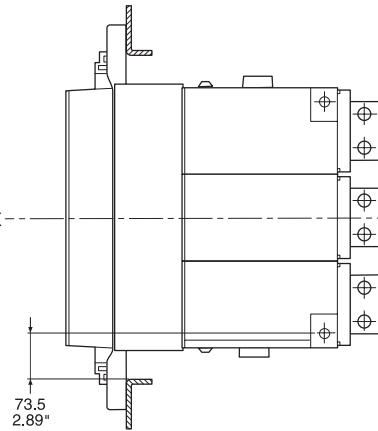
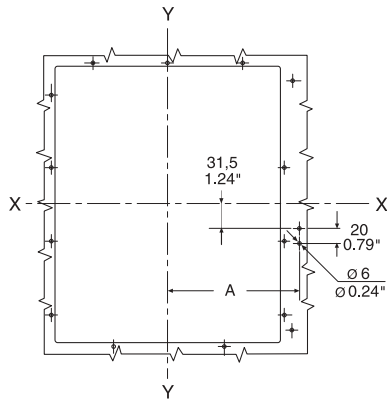

1SDC200171R0003

	A	
	3 Poles	4 Poles

E1	180	180
E2	180	180
E3	234	234
E4	270	360
E6	360	486

#### Homopolar toroid (IEC only)

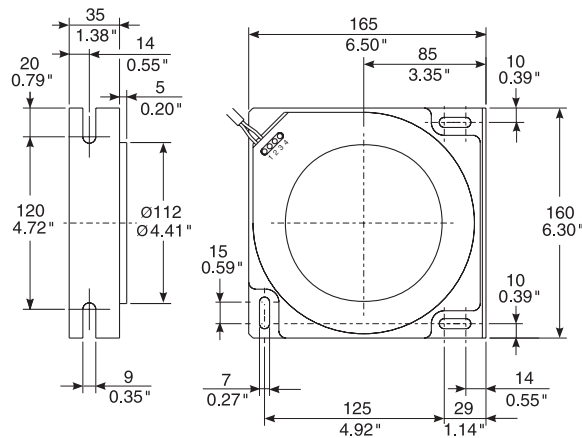

1SDC200171R0003



**Current sensor  
for the external  
neutral**

[mm/in]

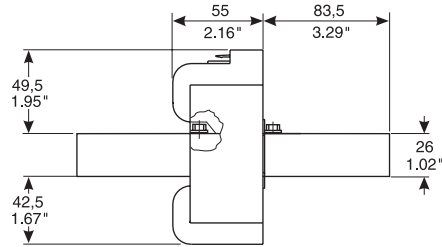

**E1 - E2 - E4**

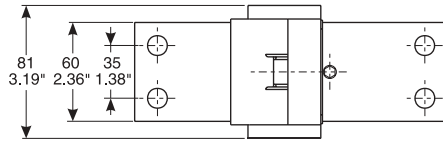

**E3 - E6**

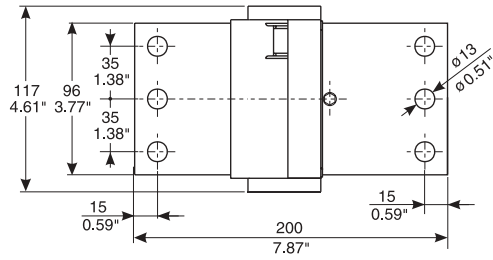

1SDC200173F0003



# Overall dimensions

## Circuit breaker accessories

### Electrical signalling of circuit breaker open/closed

[mm/in]

#### 15 supplementary auxiliary contacts

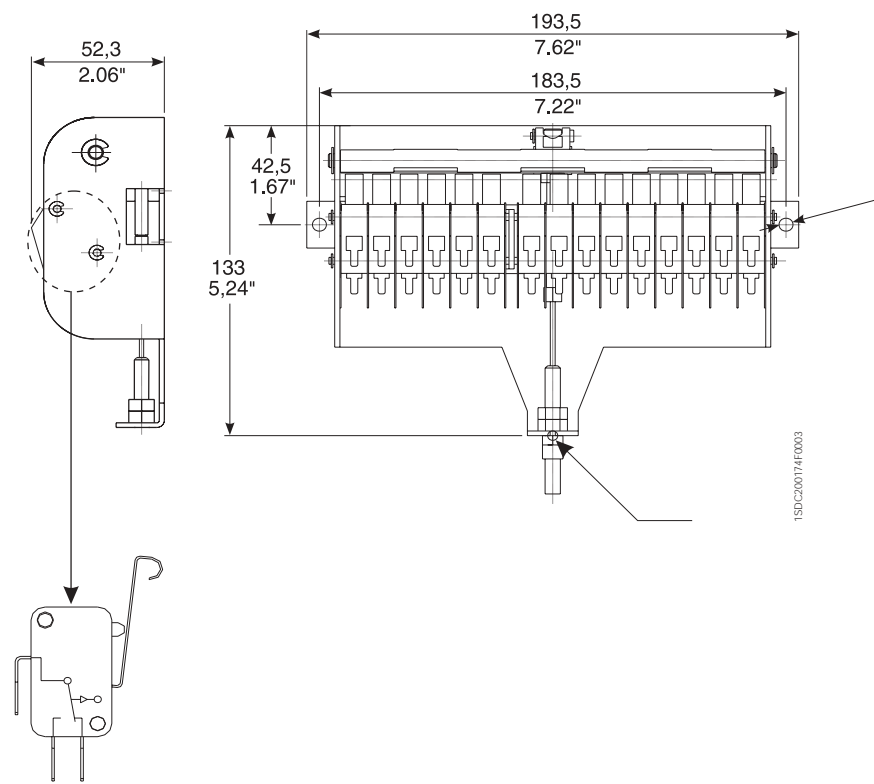

A flexible cable 650 mm / 25.59 in long is available from point "A" to point "B".

5

#### Fixed version

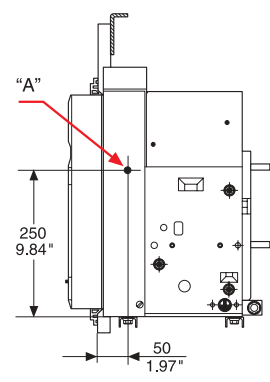

#### Draw out version

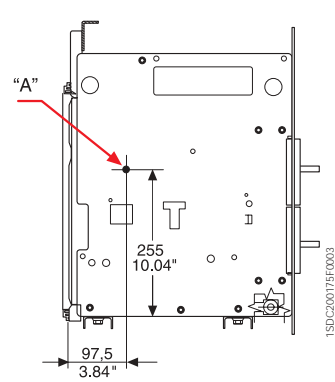

**ATS010 (IEC only)**

[mm/in]

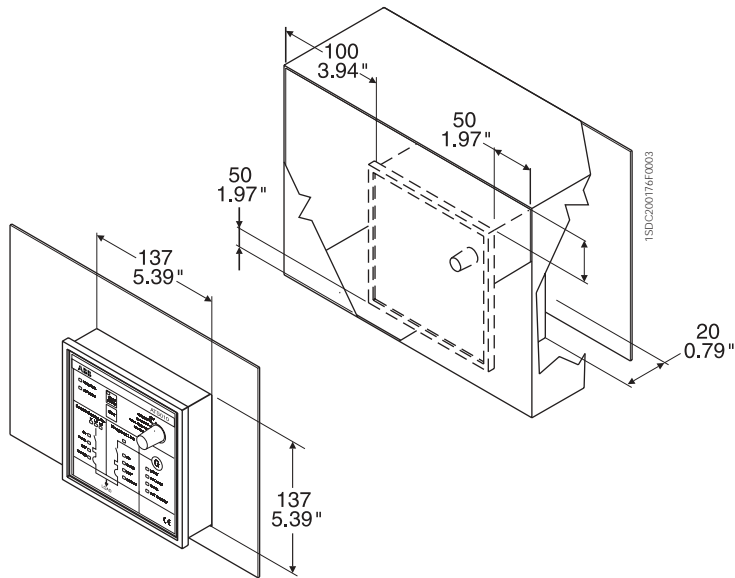

**Electronic  
time-delay device  
(IEC only)**

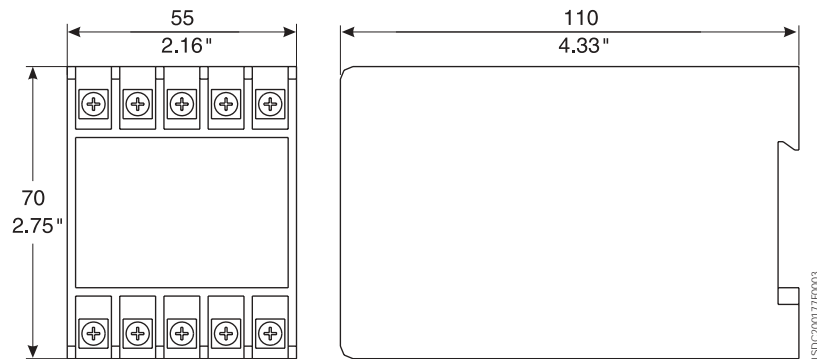



# Overall dimensions

## Circuit breaker accessories

### IP54 Protective cover

[mm/in]

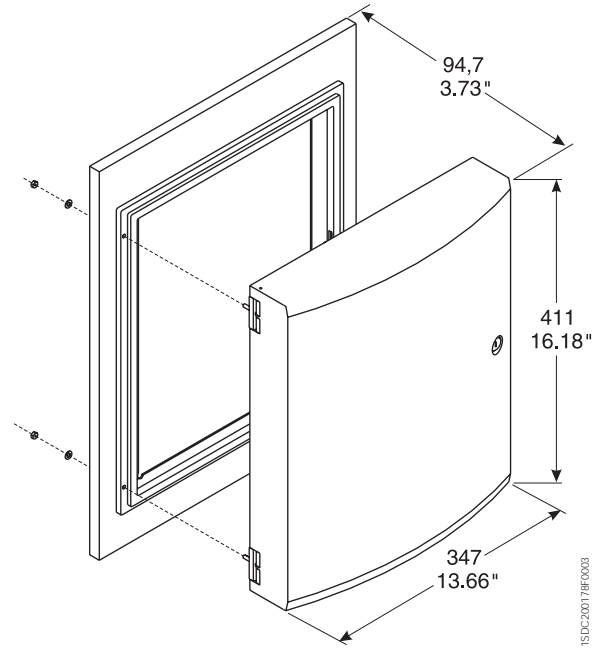

5

### PR021/K Unit (IEC only)

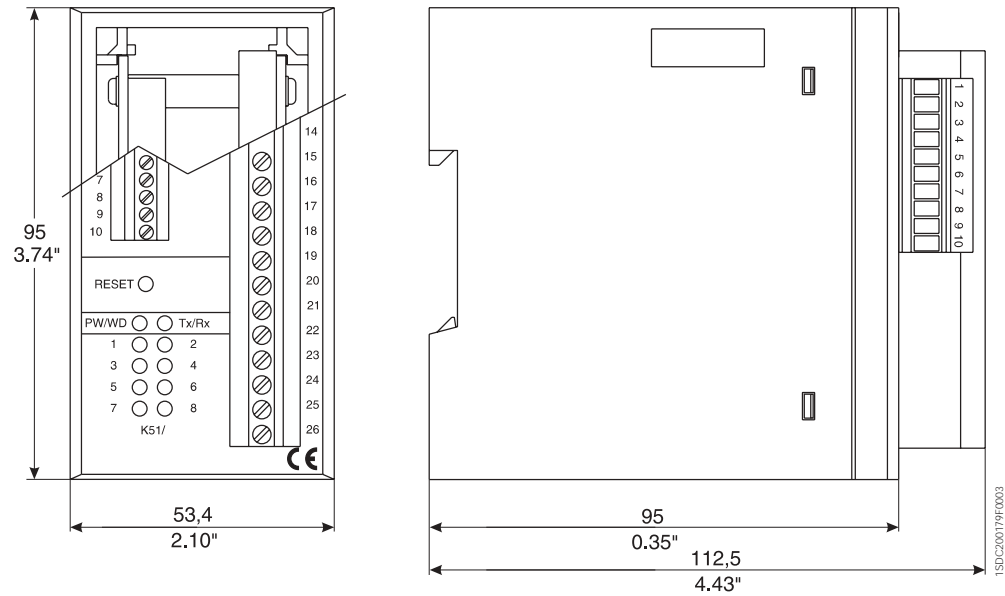





# Emax

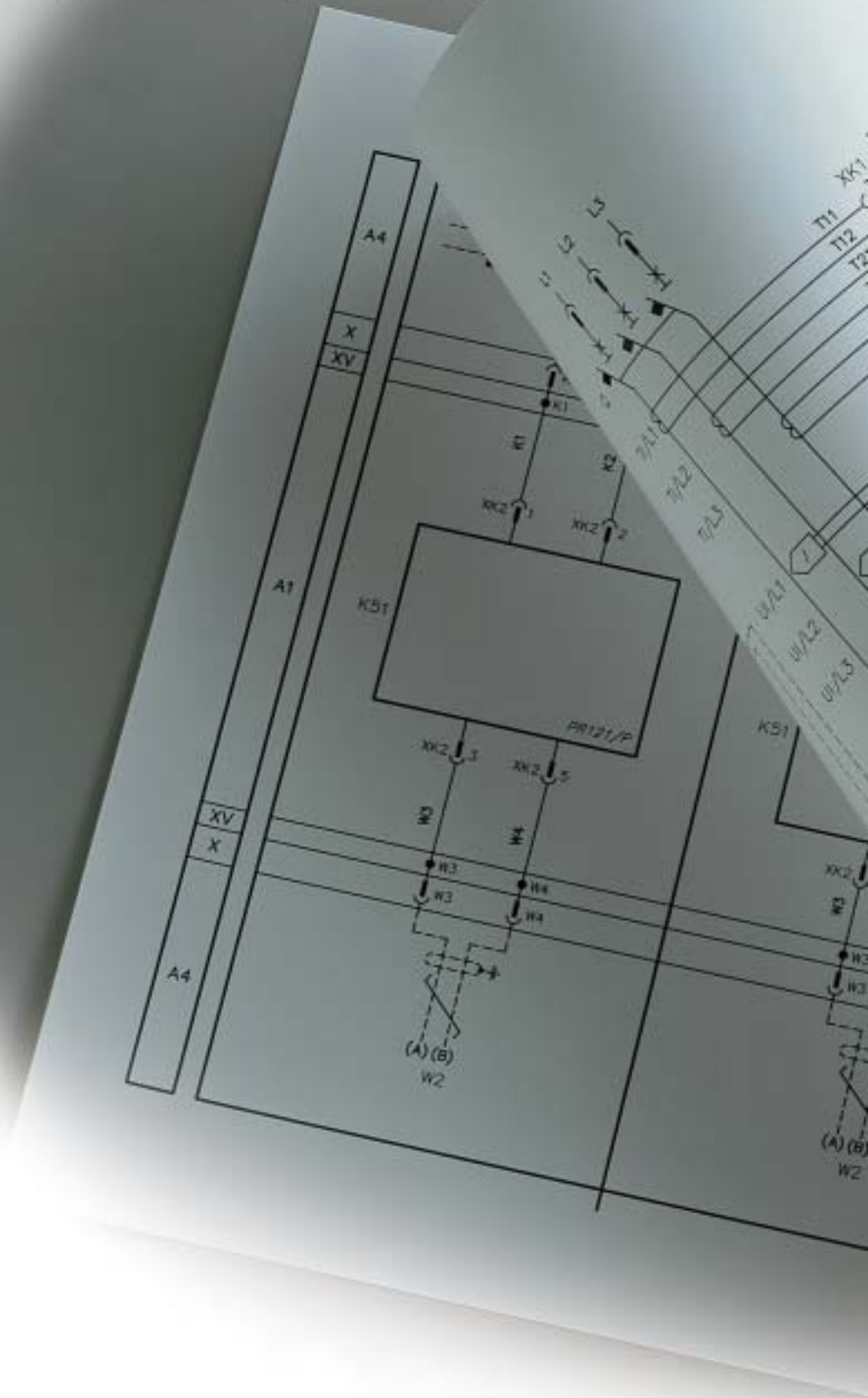

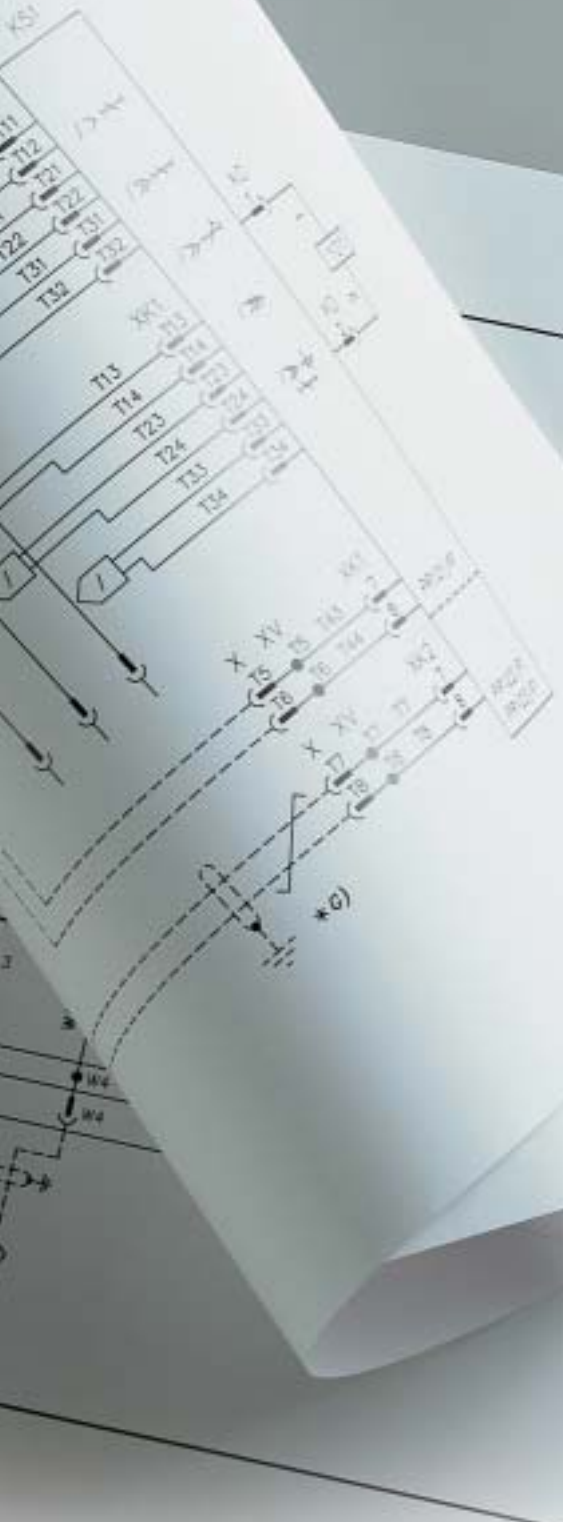

## Contents

Reading information - circuit breakers .....	6/2
Reading information - ATS010 unit .....	6/6
Circuit diagram symbols (IEC 60617 and CEI 3-14 ... 3-26 Standards) .....	6/7
<b>Circuit diagrams</b>	
Circuit breakers .....	6/8
Electrical accessories .....	6/9
Automatic transfer switch - ATS010 (IEC only) .....	6/14





# Circuit diagrams

## Reading information - circuit breakers

### Warning

Before installing the circuit breaker, carefully read notes F and O on the circuit diagrams.

### Operating status shown

The circuit diagram is shown under the following conditions:

- draw out circuit breaker, open and racked-in
- circuits de-energized
- trip units not tripped
- motor operator with springs discharged.

### Versions

Though the diagram shows a circuit breaker in draw out version, it can be applied to a fixed version circuit breaker as well.

#### Fixed version

The control circuits are fitted between terminals XV (connector X is not supplied).  
With this version, the applications indicated in figures 31 and 32 cannot be provided.

#### Draw out version

The control circuits are fitted between the poles of connector X (terminal box XV is not supplied).

#### Version without overcurrent trip unit

With this version, the applications indicated in figures 13, 14, 41, 42, 43, 44, 45, 46, 47 cannot be provided.

#### Version with PR121/P electronic trip unit

With this version, the applications indicated in figures 42, 43, 44, 45, 46, 47 cannot be provided.

#### Version with PR122/P electronic trip unit

With this version, the applications indicated in figure 41 cannot be provided.

#### Version with PR123/P electronic trip unit

With this version, the applications indicated in figure 41 cannot be provided.

### Caption

- = Circuit diagram figure number
- \* = See note indicated by letter
- A1 = Circuit breaker accessories
- A3 = Accessories applied to the cradle of the circuit breaker (for draw out version only)
- A4 = Example switchgear and connections for control and signaling, outside the circuit breaker
- AY = SOR TEST UNIT control/monitoring Unit (see note R)
- D = Electronic time-delay device of the undervoltage release, outside the circuit breaker
- F1 = Delayed-trip fuse
- K51 = PR121/P, PR122/P, PR123/P electronic trip unit with the following protection functions (see note G):
  - L overload protection with inverse long time-delay trip - setting I1
  - S short-circuit protection with inverse or definite short time-delay trip - setting I2
  - I short-circuit protection with instantaneous time-delay trip - setting I3
  - G ground fault protection with inverse short time-delay trip - setting I4
- K51/1...8 = Contacts of the PR021/K signaling unit.
- K51/GZin (DBin) = Zone discrimination: input for protection G or "reverse" direction input for protection D (only with Uaux. and PR122/P or PR123/P trip unit)
- K51/GZout (DBout) = Zone discrimination: output for protection G or "reverse" direction output for protection D (only with Uaux. and PR122/P or PR123/P trip unit)
- K51/IN1 = Digital programmable input (available only with Uaux and PR122/P or PR123/P trip unit with indicator module PR120/K)
- K51/P1...P4 = Programmable electrical signaling (available only with Uaux and PR122/P or PR123/P trip unit with indicator module PR120/K)
- K51/SZin (DFin) = Zone discrimination: input for protection S or "direct" input for protection D (only with Uaux. and PR122/P or PR123/P trip unit)
- K51/SZout (DFout) = Zone discrimination: output for protection S or "direct" output for protection D (only with Uaux. and PR122/P or PR123/P trip unit)
- K51/YC = Closing control from PR122/P or PR123/P electronic trip unit with communication module PR120/D-M
- K51/YO = Opening control from PR122/P or PR123/P electronic trip unit with communication module PR120/D-M

---



---

M	= Motor for charging the closing springs
Q	= Circuit breaker
Q/1...27	= Circuit breaker auxiliary contacts
S33M/1	= Limit contacts for spring-charging motor
S43	= Switch for setting remote/local control
S51	= Contact for electrical signaling of circuit breaker open due to tripping of the overcurrent trip unit. The circuit breaker may be closed only after pressing the reset pushbutton, or after energizing the coil for electrical reset (if available).
S75E/1...4	= Contacts for electrical signaling of circuit breaker in racked-out position (only with draw out circuit breakers)
S75I/1...4	= Contacts for electrical signaling of circuit breaker in racked-in position (only with draw out circuit breakers)
S75T/1..4	= Contacts for electrical signaling of circuit breaker in test isolated position (only with draw out circuit breakers)
SC	= Pushbutton or contact for closing the circuit breaker
SO	= Pushbutton or contact for opening the circuit breaker
SO1	= Pushbutton or contact for opening the circuit breaker with delayed trip
SO2	= Pushbutton or contact for opening the circuit breaker with instantaneous trip
SR	= Pushbutton or contact for electrical circuit breaker reset
TI/L1	= Current transformer located on phase L1
TI/L2	= Current transformer located on phase L2
TI/L3	= Current transformer located on phase L3
Uaux.	= Auxiliary power supply voltage (see note F)
UI/L1	= Current sensor (Rogowski coil) located on phase L1
UI/L2	= Current sensor (Rogowski coil) located on phase L2
UI/L3	= Current sensor (Rogowski coil) located on phase L3
UI/N	= Current sensor (Rogowski coil) located on neutral
UI/O	= Current sensor (Rogowski coil) located on the conductor connecting to ground the star point of the MV/LV transformer (see note G)
W1	= Serial interface with control system (external bus): EIA RS485 interface (see note E)
W2	= Serial interface with the accessories of PR121/P, PR122/P and PR123/P trip units (internal bus)
X	= Delivery connector for auxiliary circuits of draw out version circuit breaker
X1...X7	= Connectors for the accessories of the circuit breaker
XF	= Delivery terminal box for the position contacts of the draw out circuit breaker (located on the cradle of the circuit breaker)
XK1	= Connector for power circuits of PR121/P, PR122/P, and PR123/P trip units.
XK2 - XK3	= Connectors for auxiliary circuits of PR121/P, PR122/P and PR123/P trip units.
XO	= Connector for YO1 trip unit
XV	= Delivery terminal box for the auxiliary circuits of the fixed circuit breaker
YC	= Closing coil
YO	= Shunt trip
YO1	= Shunt trip
YO2	= Second shunt trip (see note Q)
YR	= Coil to electrically reset the circuit breaker
YU	= Undervoltage release (see notes B and Q)

# Circuit diagrams

## Reading information - circuit breakers

### Description of figures

- Fig. 1 = Motor circuit to charge the closing springs.
- Fig. 2 = Closing coil circuit.
- Fig. 4 = Shunt trip.
- Fig. 6 = Instantaneous undervoltage release (see notes B and Q).
- Fig. 7 = Undervoltage release with electronic time-delay device, outside the circuit breaker (see notes B and Q).
- Fig. 8 = Second shunt trip unit (see note Q).
- Fig. 11 = Contact for electrical signaling of springs charged.
- Fig. 12 = Contact for electrical signaling of undervoltage release energized (see notes B and S).
- Fig. 13 = Contact for electrical signaling of circuit breaker open due to tripping of the overcurrent trip unit.  
The circuit breaker may be closed only after pressing the reset pushbutton.
- Fig. 14 = Contact for electrical signaling of circuit breaker open due to tripping of the overcurrent trip unit and electrical reset coil. The circuit breaker may be closed only after pressing the reset pushbutton or energizing the coil.
- Fig. 21 = First set of circuit breaker auxiliary contacts.
- Fig. 22 = Second set of circuit breaker auxiliary contacts (not available for PR122/P and PR123/P trip units; see note V).
- Fig. 23 = Third set of supplementary auxiliary contacts outside the circuit breaker.
- Fig. 31 = First set of contacts for electrical signaling of circuit breaker in racked-in, test isolated, racked-out position.
- Fig. 32 = Second set of contacts for electrical signaling of circuit breaker in racked-in, test isolated, racked-out position.
- Fig. 41 = Auxiliary circuits of PR121/P trip units (see note F).
- Fig. 42 = Auxiliary circuits of PR122/P and PR123/P trip units (see notes F, M and V).
- Fig. 43 = Circuits of the measuring module PR120/V of the PR122/P and PR123/P trip units internally connected to the circuit breaker (optional for the trip unit PR122/P; see notes T and U).
- Fig. 44 = Circuits of the measuring module PR120/V of the PR122/P and PR123/P trip units externally connected to the circuit breaker (optional for the trip unit PR122/P; see notes O and U).
- Fig. 45 = Circuits of the communication module PR120/D-M of the PR122/P and PR123/P trip units (optional; see note E).
- Fig. 46 = Circuits of the indicator module PR120/K of the PR122/P and PR123/P trip units - connection 1 (optional; see note V).
- Fig. 47 = Circuits of the indicator module PR120/K of the PR122/P and PR123/P trip units - connection 2 (optional; see note V).
- Fig. 61 = SOR TEST UNIT control/monitoring unit (see note R).
- Fig. 62 = Circuit of the signaling module PR021/K

### Incompatibilities

The circuits indicated in the following figures cannot be supplied simultaneously on the same circuit breaker:

- 6 - 7 - 8
- 13 - 14
- 22 - 46 - 47
- 43 - 44

---

---

---

## Notes

- A) The circuit breaker is only fitted with the accessories specified in the ABB order acknowledgement. Please contact your local sales organisation.
- B) The undervoltage release is supplied for operation using a power supply branched on the supply side of the circuit breaker or from an independent source. The circuit breaker can only close when the trip unit is energized (there is a mechanical lock on closing). If the same power supply is used for the closing coil and undervoltage release and the circuit breaker is required to close automatically when the auxiliary power supply comes back on, a 30 ms delay must be introduced between the undervoltage release accept signal and the energizing of the closing coil. This may be achieved using an external circuit comprising a permanent make contact, the contact shown in fig. 12 and a time-delay relay.
- E) For the EIA RS485 serial interface connection see document ITSCE - RH0298 regarding MODBUS communication
- F) The auxiliary voltage  $U_{aux}$  allows actuation of all operations of the PR121/P, PR122/P and PR123/P trip units. Having requested a  $U_{aux}$  insulated from ground, one must use "galvanically separated converters" in compliance with IEC 60950 (UL 1950) or equivalent standards that ensure a common mode current or leakage current (see IEC 478/1, CEI 22/3) not greater than 3.5 mA, IEC 60364-41 and CEI 64-8.
- G) Ground fault protection is available with the PR122/P and PR123/P trip units by means of a current sensor located on the conductor connecting to ground the star center of the MV/LV transformer. The connections between terminals 1 and 2 (or 3) of current transformer UI/O and poles T7 and T8 of the X (or XV) connector must be made with a two-pole shielded and stranded cable (see user manual), no more than 15 m long. The shield must be grounded on the circuit breaker side and current sensor side.
- N) With PR122/P and PR123/P trip units, the connections to the zone discrimination inputs and outputs must be made with a two-pole shielded and stranded cable (see user manual), no more than 300 m long. The shield must be grounded on the discrimination input side.
- O) Systems with rated voltage of less than 100V or greater than 690V require the use of an insulation voltage transformer to connect to the busbars (connect according to the insertion diagrams provided in the manual).
- P) With PR122/P and PR123/P trip units with communication module PR120/D-M, the power supply for coils YO and YC must not be taken from the main power supply. The coils can be controlled directly from contacts K51/YO and K51/YC with maximum voltages of 60 V DC and 240-250 V AC for the PR122/P, and 240-250 V DC for the PR123/P.
- Q) The second shunt trip may be installed as an alternative to the undervoltage release.
- R) The SOR TEST UNIT + shunt trip (YO) is guaranteed to operate starting at 75% of the  $U_{aux}$  of the shunt trip itself. While the YO power supply contact is closing (short-circuit on terminals 4 and 5), the SOR TEST UNIT is unable to detect the opening coil status. Consequently:
  - for continuously powered opening coil, the TEST FAILED and ALARM signals will be activated
  - if the coil opening command is of the pulsing type, the TEST FAILED signal may appear at the same time. In this case, the TEST FAILED signal is actually an alarm signal only if it remains lit for more than 20s.
- S) Also available in the version with normally-closed contact
- T) The connection between pin 1 of the connector XK5 to the internal neutral conductor is provided by four-pole circuit breakers, while pin 1 of the connector XK5 is connected to pin T1 of the connector X (or XV) by means of three-pole circuit breakers.
- U) The measuring module PR120/V is always supplied with relay PR123/P.
- V) If fig. 22 is present (second set of auxiliary contacts) simultaneously as PR122/P or PR123/P trip unit, the contacts for the zone discrimination in fig. 42 (K51/Zin, K51/Zout, K51/Gzin and K51/Gzout) are not wired. In addition, the indicator module PR120/K in figures 46 and 47 cannot be supplied.



# Circuit diagrams

## Reading information - ATS010 unit

### Operating status shown of the ATS010 unit

The circuit diagram is for the following conditions:

- circuit breakers open and racked-in #
- generator not under alarm
- closing springs discharged
- trip units not tripped \*
- ATS010 not powered
- generator in automatic mode and not started
- generator switching enabled
- circuits de-energized
- logic enabled by means of special input (terminal 47).

# This diagram shows draw out circuit breakers, but is also valid for fixed version circuit breakers: the auxiliary circuits of the circuit breakers are not headed to connector X but to terminal box XV; also connect terminal 17 to 20 and terminal 35 to 38 on the ATS010 device.

\* This diagram shows circuit breakers with trip units, but is also valid for circuit breakers without trip units: connect terminal 18 to 20 and terminal 35 to 37 of the ATS010 device.

@ This diagram shows four-pole circuit breakers but is also valid for two-pole circuit breakers: use only terminals 26 and 24 (phase and neutral) for the voltage connection of the normal power supply to the ATS010 device; also use the Q61/2 two-pole rather than four-pole auxiliary protection circuit breaker.

### Caption

A1	= Circuit breaker applications
A	= ATS010 device for automatic switching of two circuit breakers
F1	= Delayed-trip fuse
K1	= Auxiliary contact for emergency power supply voltage present
K2	= Auxiliary contact for normal supply voltage present
K51/Q1	= Overcurrent relay of the emergency power supply line *
K51/Q2	= Overcurrent relay of the normal power supply line *
M	= Motor for charging the closing springs
Q/1	= Auxiliary contact of the circuit breaker
Q1	= Emergency power supply line circuit breaker
Q	= Normal power supply line circuit breaker
Q61/1-2	= Thermomagnetic circuit breakers for isolating and protecting the auxiliary circuits @
S11...S16	= Signal contacts for the inputs of the ATS010 device
S33M/1	= Limit contact of the closing springs
S51	= Contact for the electrical signaling of circuit breaker open due to trip unit tripped *
S75I/1	= Contact for the electrical signaling of draw out circuit breaker racked-in #
TI/ ...	= Current transformers for the trip unit power supply
X	= Connector for the auxiliary circuits of the draw out circuit breaker
XF	= Delivery terminal box for the position contacts of the draw out circuit breaker
XV	= Delivery terminal box for the auxiliary circuits of the fixed version circuit breaker
YC	= Closing coil
YO	= Shunt trip

### Note

A) For the auxiliary circuits of the circuit breakers, see the circuit diagram of the circuit breaker/accessory.

The applications shown in the following figures are required: 1 - 2 - 4 - 13 (only if the trip unit is supplied) - 21 - 31 (only for draw out circuit breakers).

# Circuit diagrams

## Circuit diagram symbols (IEC 60617 and CEI 3-14 ... 3-26 Standards)

	Shield (may be drawn in any shape)		Terminal		Position switch (limit switch) change-over break before make contact
	Delay		Plug and socket (male and female)		Circuit breaker- disconnector with automatic release
	Mechanical connection (link)		Motor (general symbol)		Switch-disconnector (on-load isolating switch)
	Manually operated control (general case)		Current transformer		Operating device (general symbol)
	Operated by turning		Voltage transformer		Instantaneous overcurrent or rate-of-rise relay
	Operated by pushing		Winding of three-phase transformer, connection star		Overcurrent relay with adjustable short time-lag characteristic
	Equipotentiality		Make contact		Overcurrent relay with inverse short time-lag characteristic
	Converter with galvanic separator		Break contact		Overcurrent relay with inverse long time-lag characteristic
	Conductors in a screened cable (i.e., 3 conductors shown)		Change-over break before make contact		Earth fault overcurrent relay with inverse short time-lag characteristic
	Twisted conductors (i.e., 3 conductors shown)		Position switch (limit switch), make contact		Fuse (general symbol)
	Connection of conductors		Position switch (limit switch), break contact		Current sensing element

# Circuit diagrams

## Circuit breakers

### Operating status

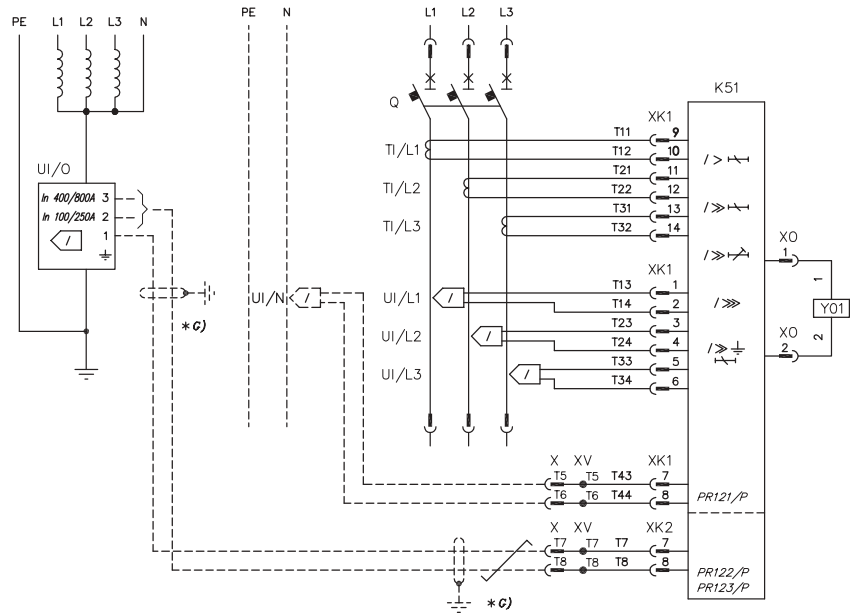

Three-pole circuit breaker with PR121/P, PR122/P or PR123/P electronic trip unit

1SDC200243F0001

6

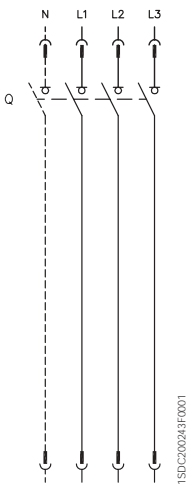

1SDC200243F0001

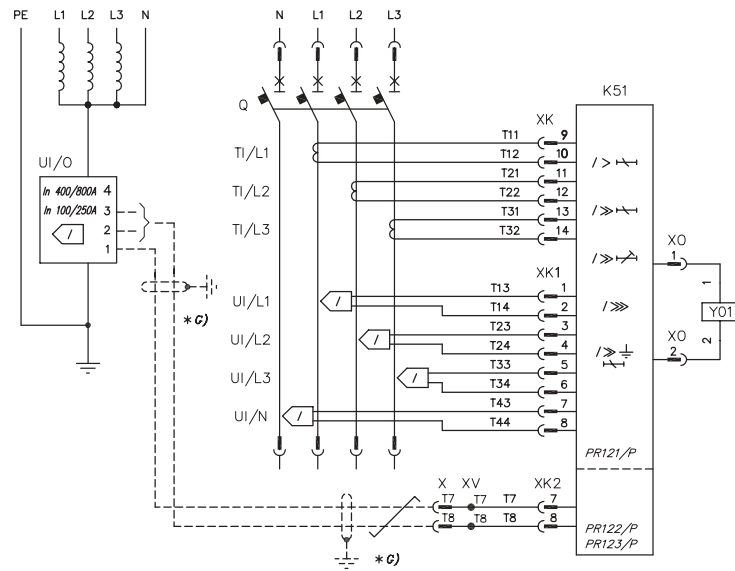

1SDC200244F0001

Three- or four-pole switch

Four-pole circuit breaker with PR121/P, PR22/P or PR123P electronic trip unit



# Circuit diagrams

## Electrical accessories

### Motor operator, shunt trip, closing coil and undervoltage release

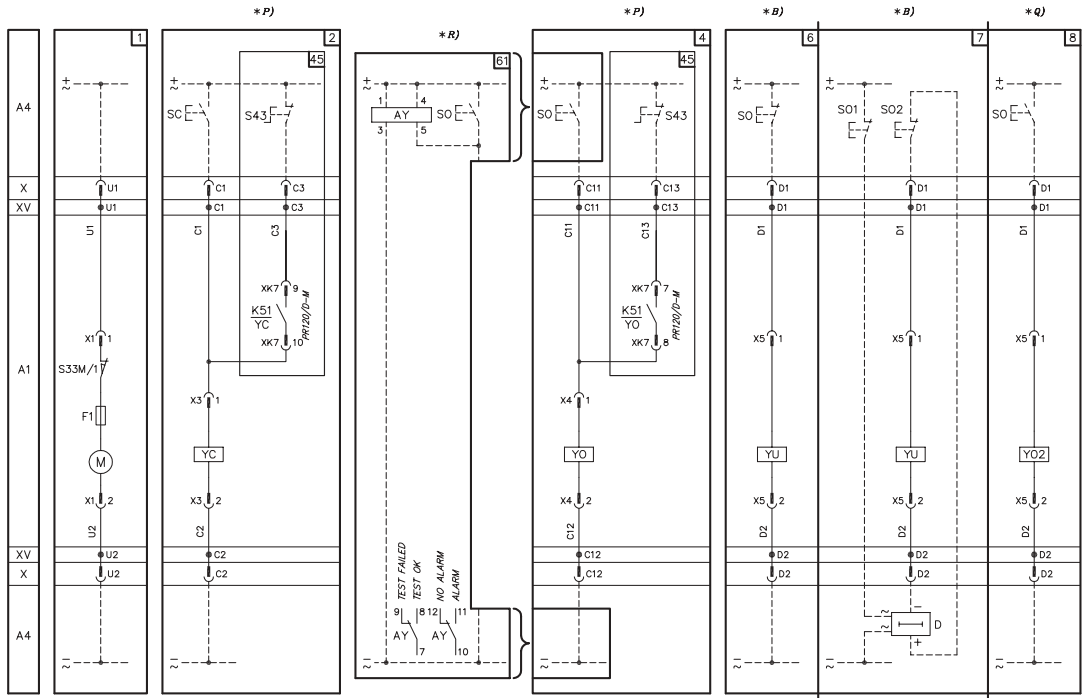

### Signaling contacts

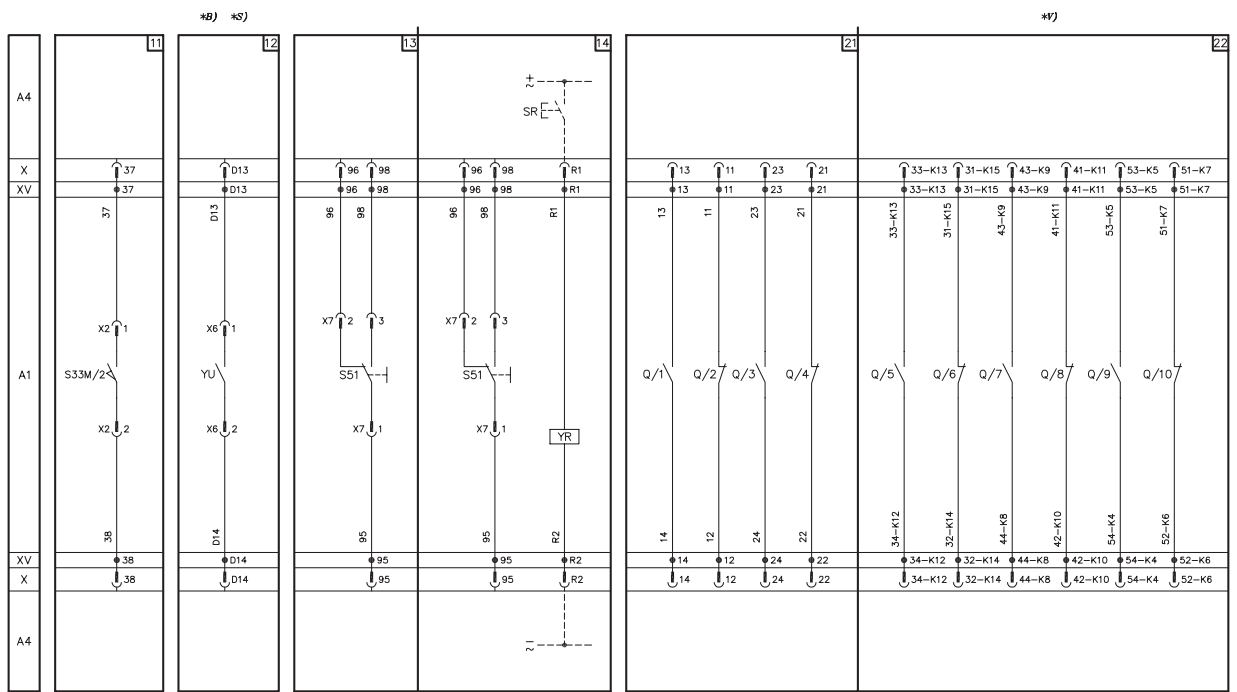





# Circuit diagrams

## Electrical accessories

### Signaling contacts

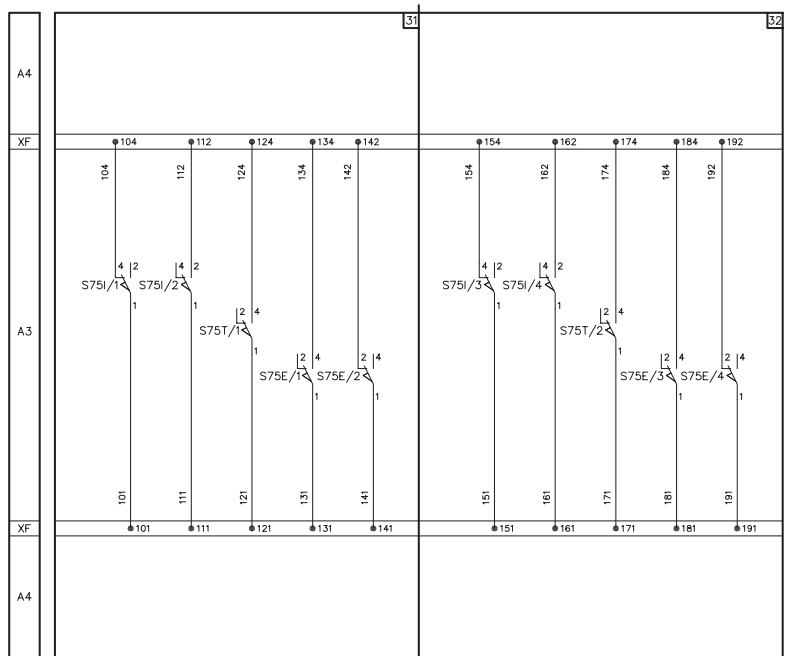
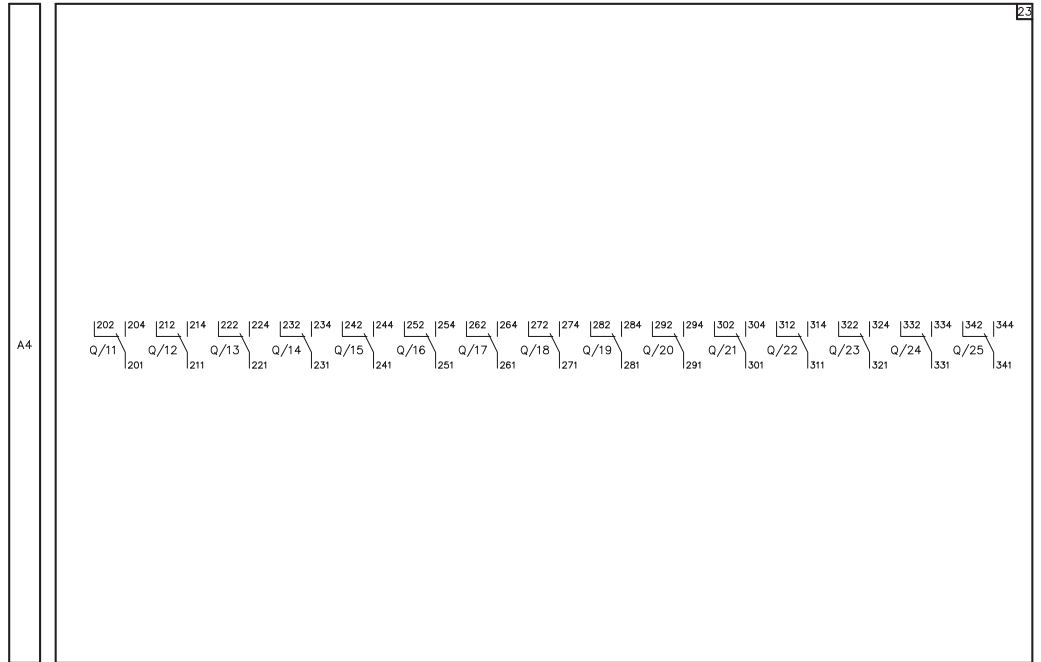

6

## Auxiliary circuits of the PR121, PR122 and PR123 trip units

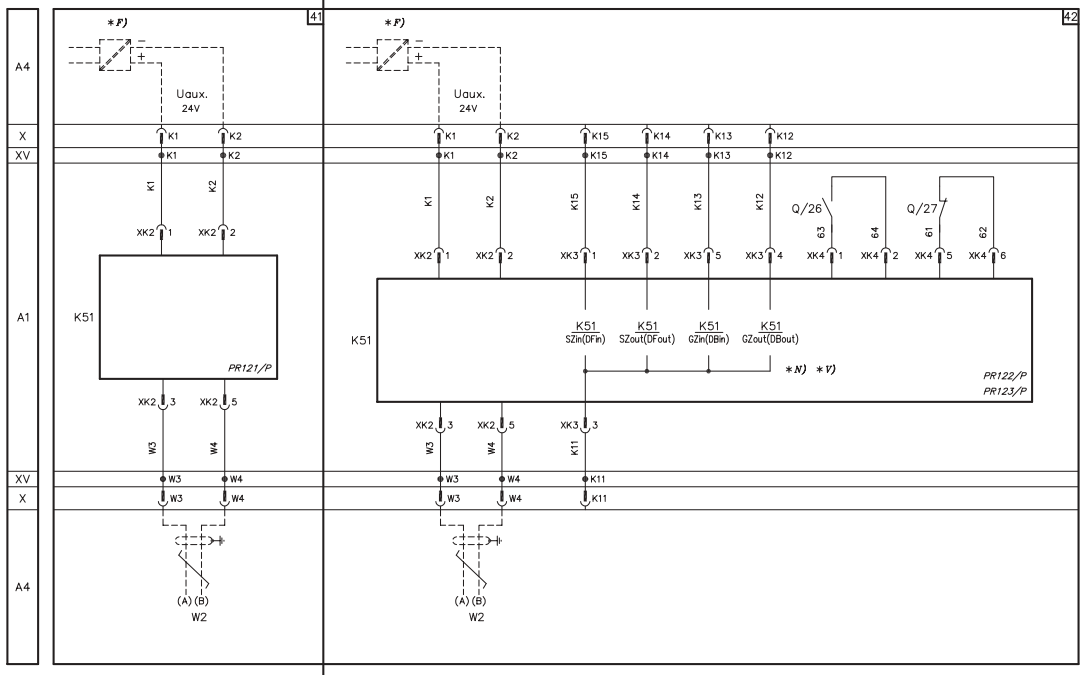

TSDC002490001

## Measuring module PR120/V

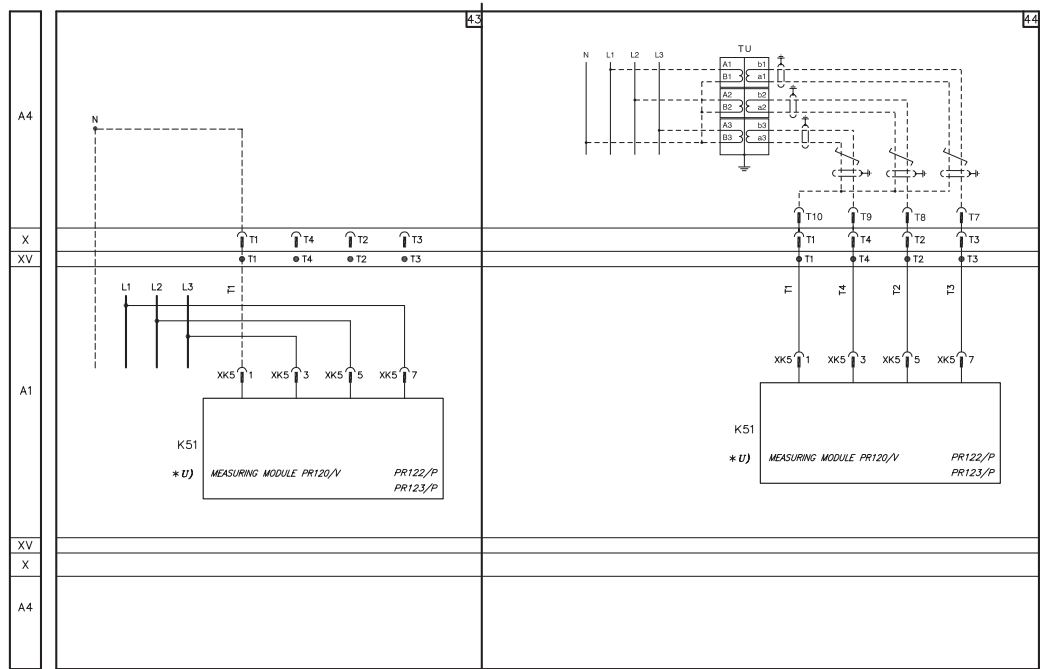

TSDC002500001



# Circuit diagrams

## Electrical accessories

### Communication module PR120/D-M (IEC only)

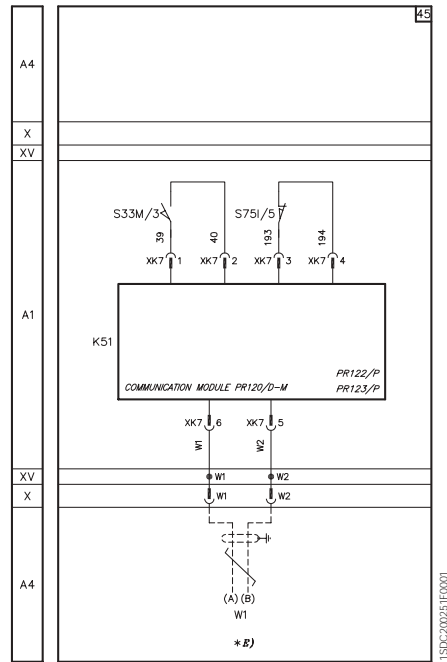

### Signaling module PR120/K

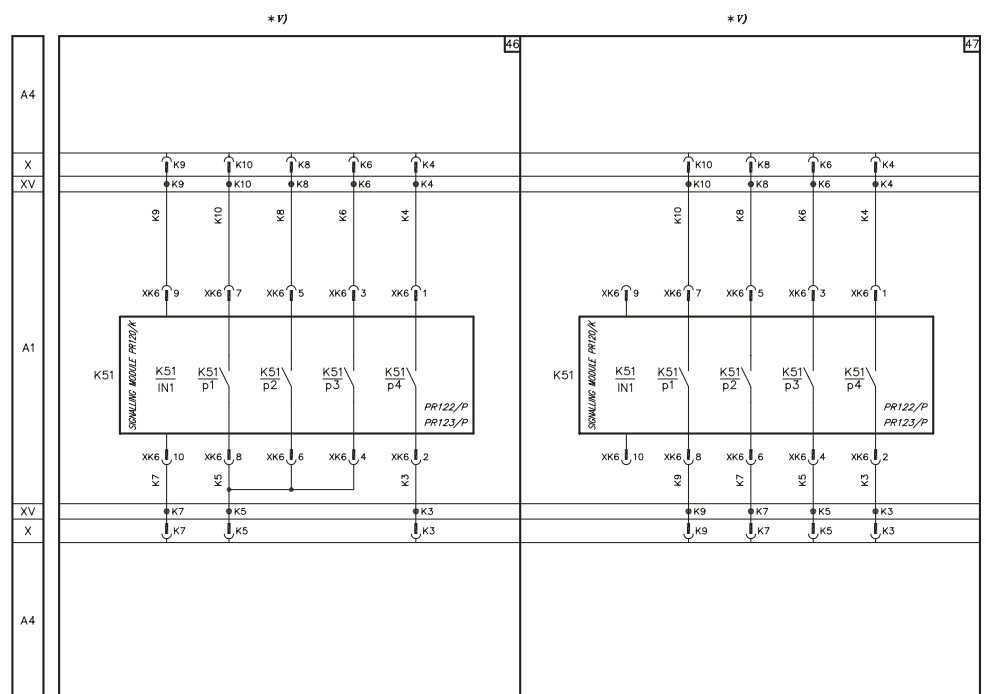

6

# PR021/K Signaling unit

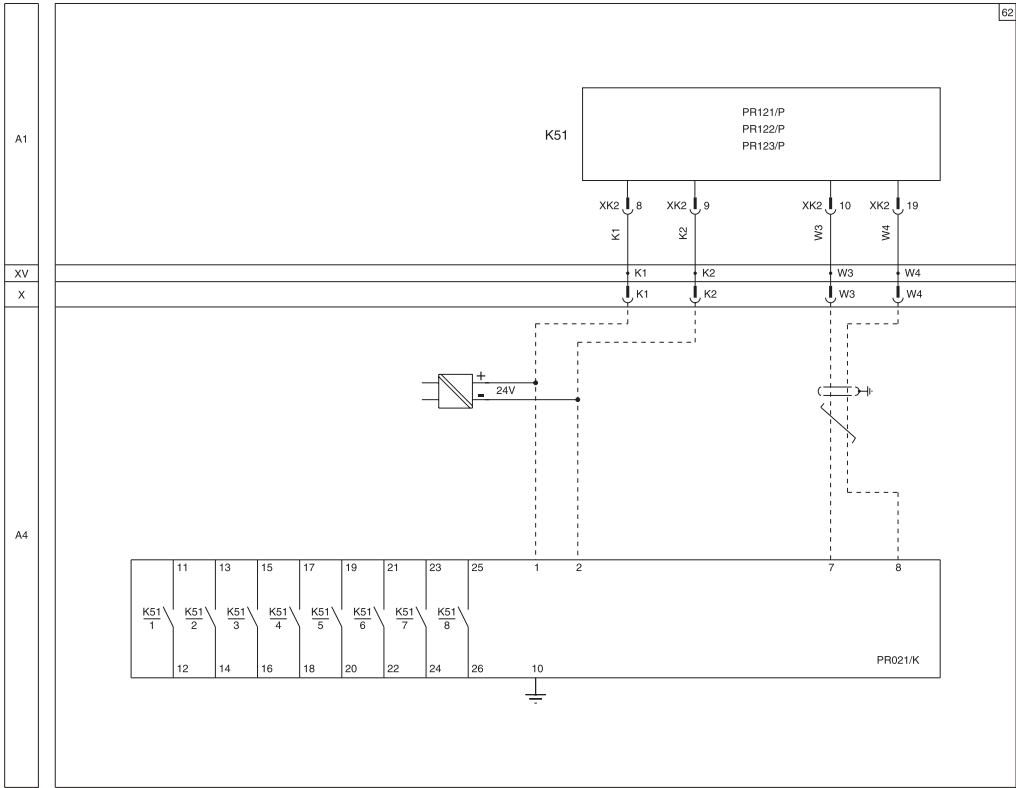

1SDC300255F0001

# Circuit diagrams

## Automatic transfer switch ATS010 (IEC only)

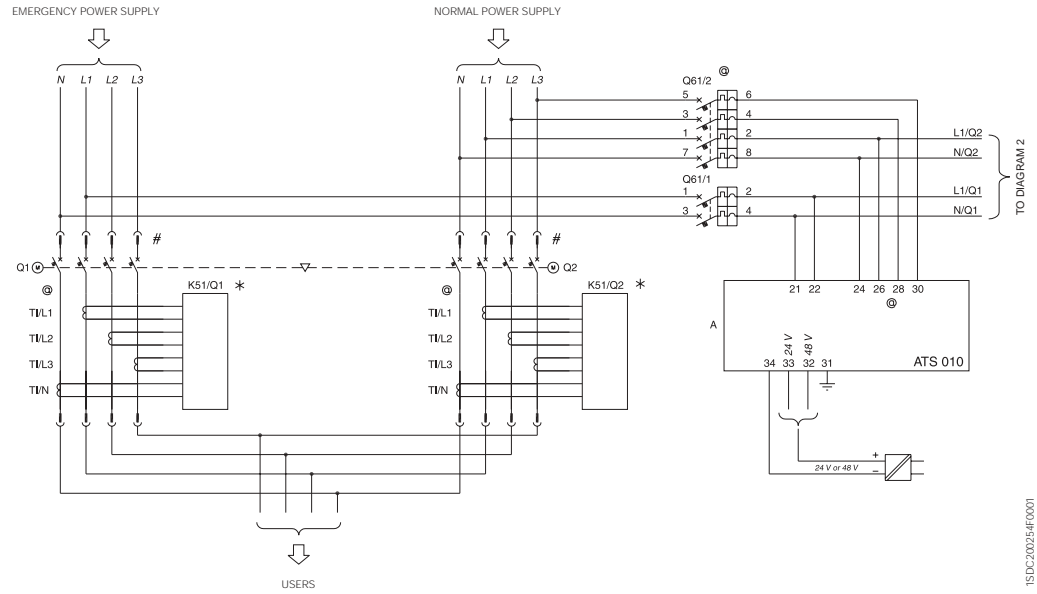

1SD0C002055F0001

WITHOUT AUXILIARY SAFETY POWER SUPPLY

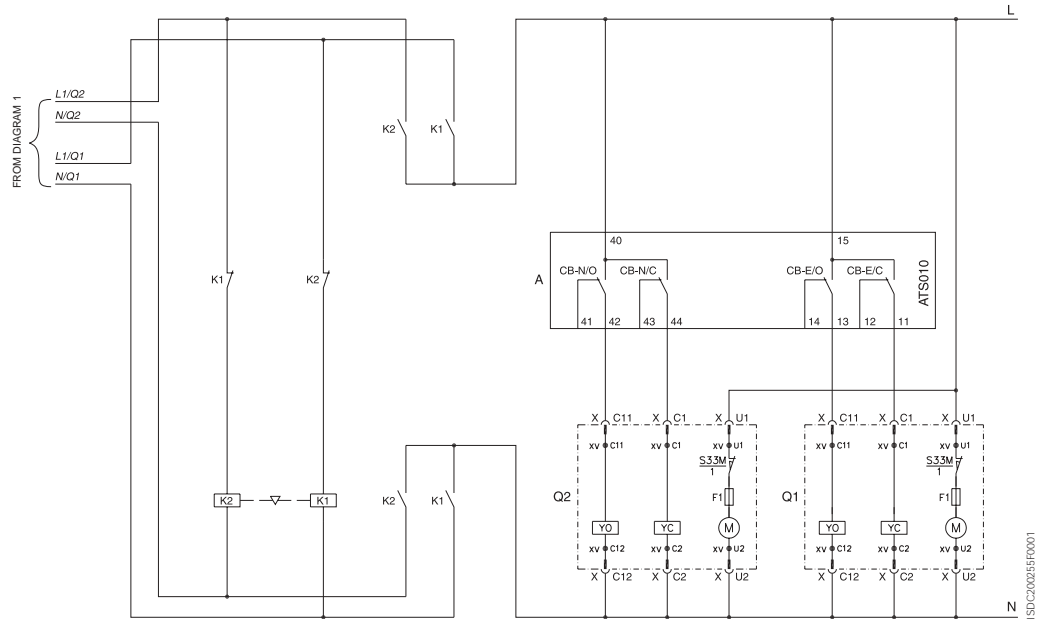

1SD0C002055F0001

6

WITH AUXILIARY SAFETY POWER SUPPLY

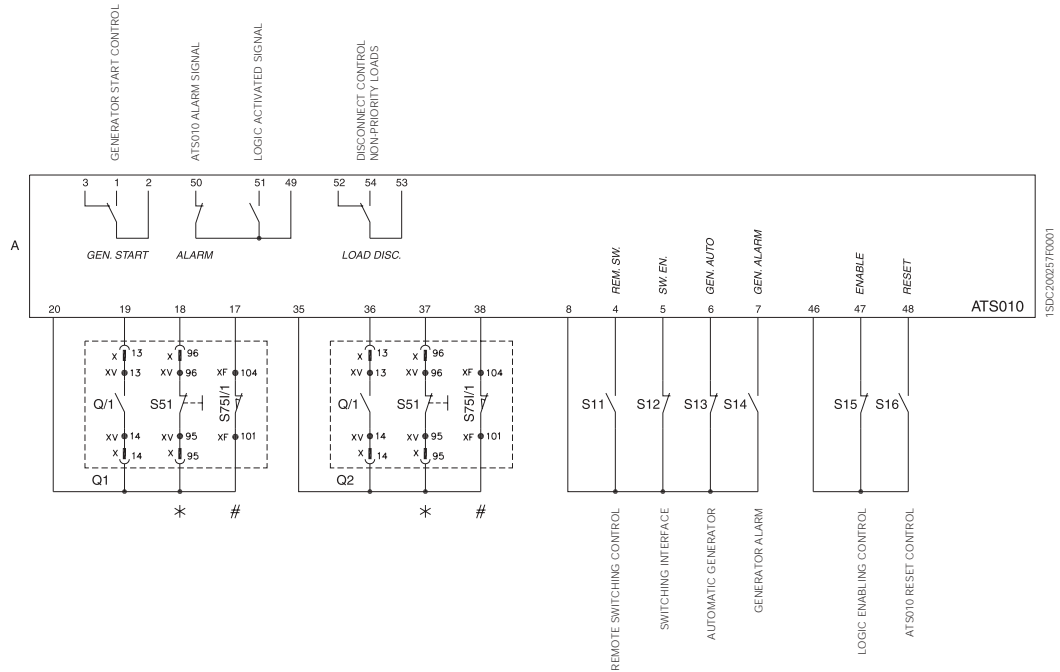
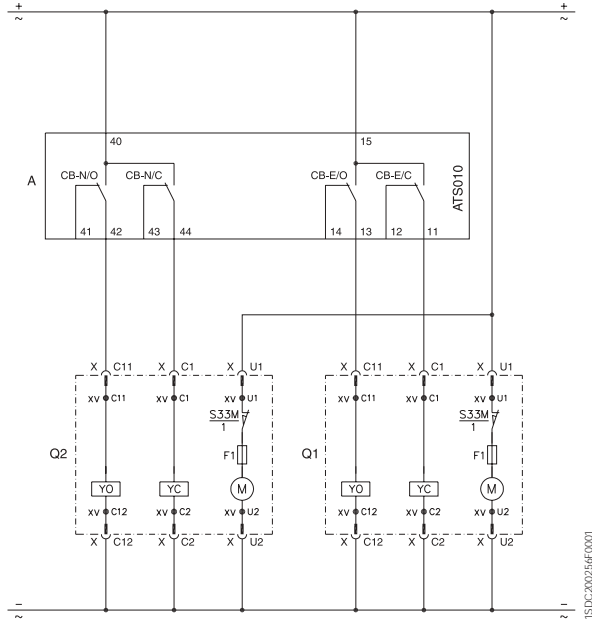



**ABB Inc.**  
1206 Hatton Road  
Wichita Falls, TX 76302 - U.S.A.  
Tel.: (888) 385-1221 - (940) 397-7000  
Fax: (940) 397-7001

[www.abb-control.com](http://www.abb-control.com)

**ABB Inc.**  
3299, boul. J.B. Deschamps  
Lachine, QC H8T 3E4 - CANADA  
Tel.: (514) 420-3100  
Fax: (514) 420-3137

[www.abb.ca](http://www.abb.ca)

Due to possible developments of standards as well as of materials,  
the characteristics and dimensions specified in the present catalogue  
may only be considered binding after confirmation by ABB Inc.