

# Drive<sup>IT</sup> Low Voltage General Purpose Motors



**IndustrialIT**  
enabled

**ABB**

# Making you more competitive

ABB's General purpose motors are readily available from central stock locations and distributors throughout the world. While designed for standard and straightforward uses, the motors can be modified to meet most specifications. Built to the highest manufacturing standards, the General purpose motors use the best materials sourced from around the world. This brings a quality and reliability that can see motors operating for over 30 years. Competitively priced, the motors meet Eff2 energy efficient classification, with Eff1 as option.

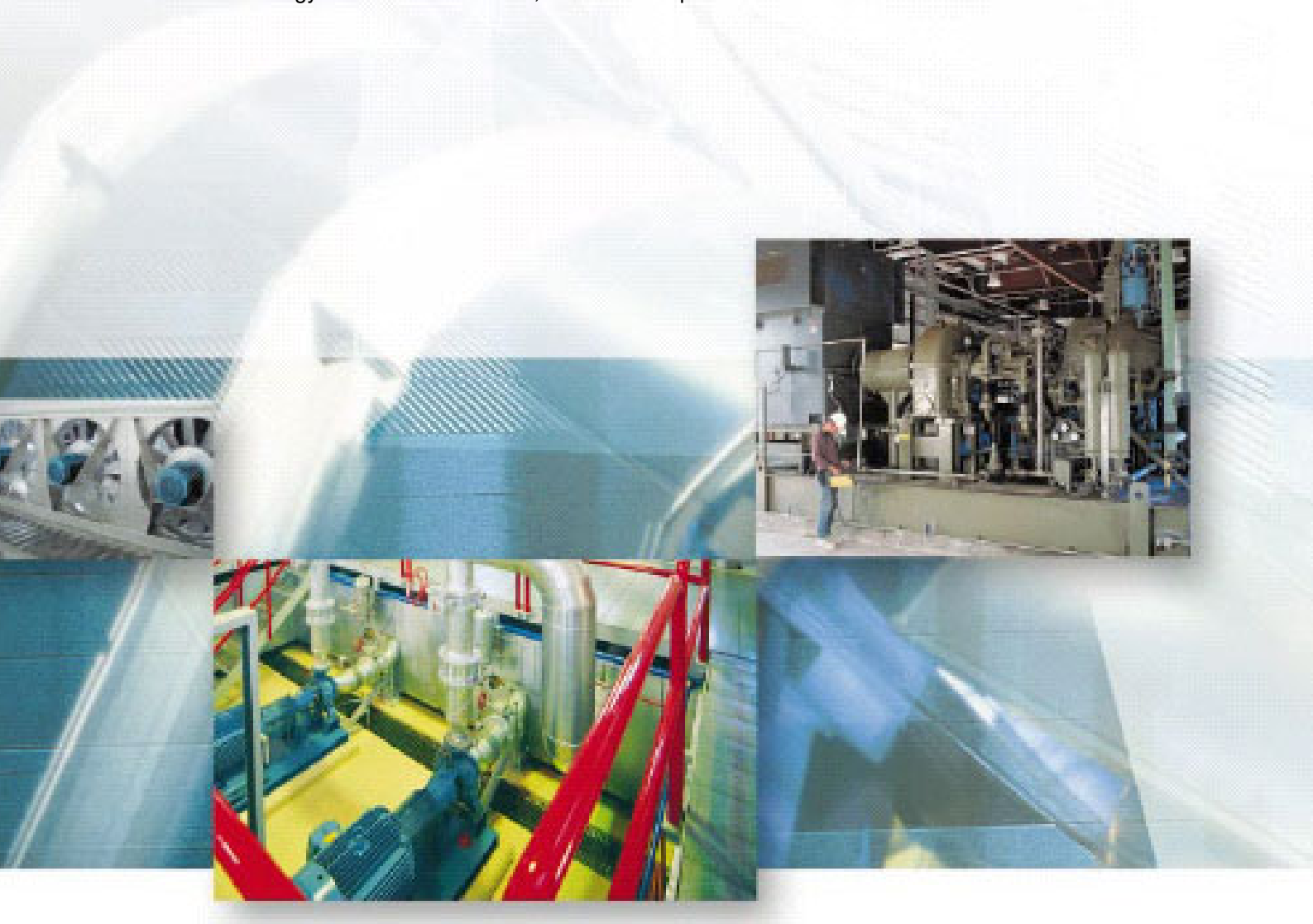

## Industrial<sup>IT</sup>

As a key element of its business strategy, ABB has committed to a broad program of product development and positioning under the Industrial<sup>IT</sup> umbrella. This initiative is geared towards increasing standardization of ABB products as the 'building blocks' of larger solutions, while incorporating functionality that will allow multiple products to interact seamlessly as components of real-time automation and information systems.

Motors and generators represent one of the fundamental building blocks in the Industrial<sup>IT</sup> architecture.

*ABB ([www.abb.com](http://www.abb.com)) is a leader in power and automation technologies that enable utility and industry customers to improve performance while lowering environmental impacts. The ABB Group of companies operates in around 100 countries and employs around 133,000 people.*

# Drive<sup>IT</sup> Low Voltage General Purpose Motors

Sizes 56 to 400, from 0.055 to 710 kW

	Contents	Page	
<b>1</b>	<b>General information</b>	<b>4</b>	<b>1</b>
<b>2</b>	<b>Aluminium motors</b>	<b>11</b>	<b>2</b>
<b>3</b>	<b>Steel motors</b>	<b>79</b>	<b>3</b>
<b>4</b>	<b>Cast iron motors</b>	<b>111</b>	<b>4</b>
<b>5</b>	<b>Open drip proof motors</b>	<b>145</b>	<b>5</b>
<b>6</b>	<b>Brake motors</b>	<b>165</b>	<b>6</b>
<b>7</b>	<b>Single phase motors</b>	<b>191</b>	<b>7</b>
<b>8</b>	<b>Integral motors</b>	<b>209</b>	<b>8</b>

ABB reserves the right to change the design, technical specification and dimensions without prior notice.

# General information

## Standards

ABB motors are of the totally enclosed, three phase squirrel cage type, built to comply with international IEC and EN standards. Motors conforming to other national and international specifications are also available on request.

All production units are certified to ISO 9001 international quality standard as well ISO 14000 environmental standard and confirm to all applicable EU Directives.

### IEC / EN

Electrical	Mechanical
IEC/EN 60034-1	IEC 60072
IEC/EN 60034-2	IEC/EN 60034-5
IEC 60034-8	IEC/EN 60034-6
IEC 60034-12	IEC/EN 60034-7
	IEC/EN 60034-9
	IEC 60034-14

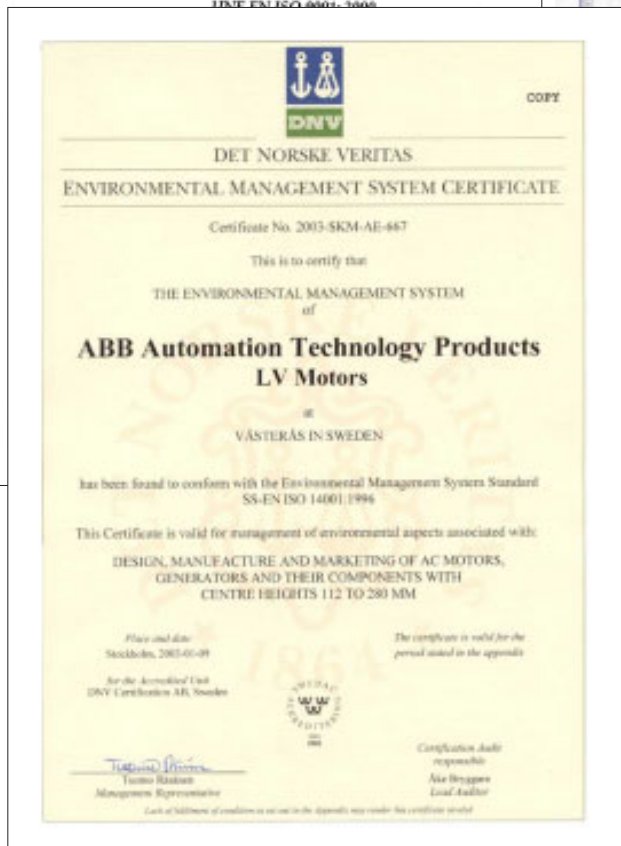

# Motors for EU motor efficiency levels

A Europe-wide agreement will ensure that the efficiency levels of electric motors manufactured in Europe are clearly displayed. In contrast to the American legislation on motor efficiency the European agreement does not establish mandatory efficiency levels.

It basically establishes three classes giving motor manufacturers an incentive to qualify for a higher class.

ABB is one of only a handful of leading motor manufacturers in Europe to have a motor range to meet or exceed the minimum efficiencies stated in the highest level of the EU agreement of LV motors.

These efficiency levels apply to 2- and 4-pole, three phase squirrel cage induction motors rated for 400V, 50 Hz with S1 duty class with the

output 1.1 to 90 kW, which account for the largest volume on the market.

The efficiency of motors from different manufacturers are collated in a database, EURODEEM, published by the European Commission. It is accessible over the Internet at <http://iamest.jrc.it/projects/eem/eurodeem.htm>.



## EU efficiency classes for 2-pole motors

Output kW	2-pole Boarderline	
	EFF2/EFF3	EFF1/EFF2
1.1	76.2	82.8
1.5	78.5	84.1
2.2	81.0	85.6
3	82.6	86.7
4	84.2	87.6
5.5	85.7	88.6
7.5	87.0	89.5
11	88.4	90.5
15	89.4	91.3
18.5	90.0	91.8
22	90.5	92.2
30	91.4	92.9
37	92.0	93.3
45	92.5	93.7
55	93.0	94.0
75	93.6	94.6
90	93.9	95.0

## EU efficiency classes for 4-pole motors

Output kW	4-pole Boarderline	
	EFF2/EFF3	EFF1/EFF2
1.1	76.2	83.8
1.5	78.5	85.0
2.2	81.0	86.4
3	82.6	87.4
4	84.2	88.3
5.5	85.7	89.2
7.5	87.0	90.1
11	88.4	91.0
15	89.4	91.8
18.5	90.0	92.2
22	90.5	92.6
30	91.4	93.2
37	92.0	93.6
45	92.5	93.9
55	93.0	94.2
75	93.6	94.7
90	93.9	95.0

## ABB Three phase induction motors, 400 V 50 Hz - EU motor efficiency levels

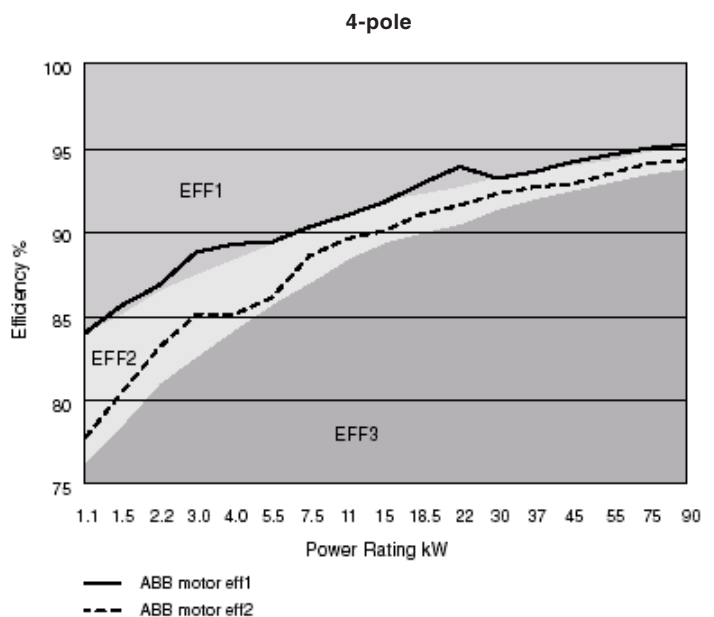
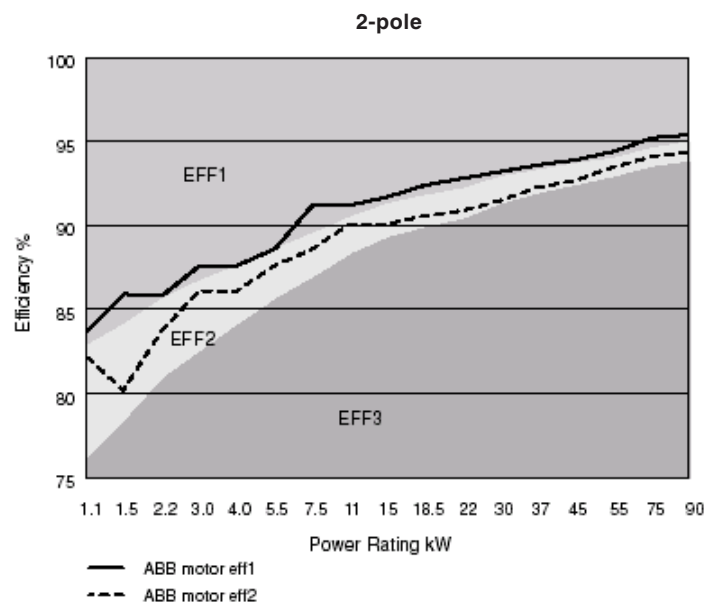









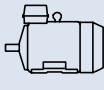

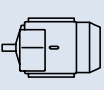
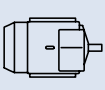
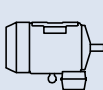
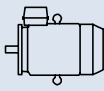

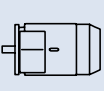
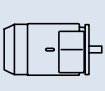
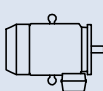
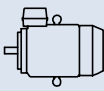
# General technical specification

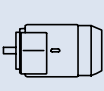
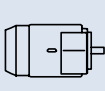
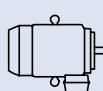
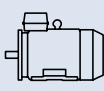
## Mechanical and electrical design

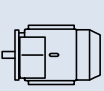
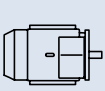
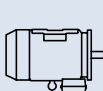
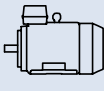
### Mounting arrangements

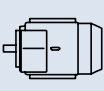
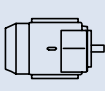
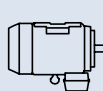
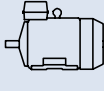
1

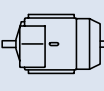
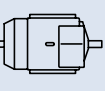
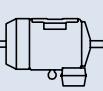
	Codell/Codell						Product code pos. 12
Foot-mounted motor.	IM B3 IM 1001	IM V5 IM 1011	IM V6 IM 1031	IM B6 IM 1051	IM B7 IM 1061	IM B8 IM 1071	A = foot-mounted, term.box top R = foot-mounted, term.box RHS L = foot-mounted, term.box LHS
							
Flange-mounted motor, large flange	IM B5 IM 3001	IM V1 IM 3011	IM V3 IM 3031	*) IM 3051	*) IM 3061	*) IM 3071	B = flange mounted, large flange
							
Flange-mounted motor, small flange	IM B14 IM 3601	IM V18 IM 3611	IM V19 IM 3631	*) IM 3651	*) IM 3661	*) IM 3671	C = flange mounted, small flange
							
Foot- and flange-mounted motor with feet, large flange	IM B35 IM 2001	IM V15 IM 2011	IM V36 IM 2031	*) IM 2051	*) IM 2061	*) IM 2071	H = foot/flange-mounted, term.box top S = foot/flange-mounted, term.box RHS T = foot/flange-mounted, term.box LHS
							
Foot- and flange-mounted motor with feet, small flange	IM B34 IM 2101	IM V17 IM 2111	IM 2131	IM 2151	IM 2161	IM 2171	J = foot/flange-mounted, small flange
							
Foot-mounted motor, shaft with free extensions	IM 1002	IM 1012	IM 1032	IM 1052	IM 1062	IM 1072	
							
*) Not stated in IEC 60034-7.							

# Cooling

Designation system concerning methods of cooling refers to standard IEC 60034-6.

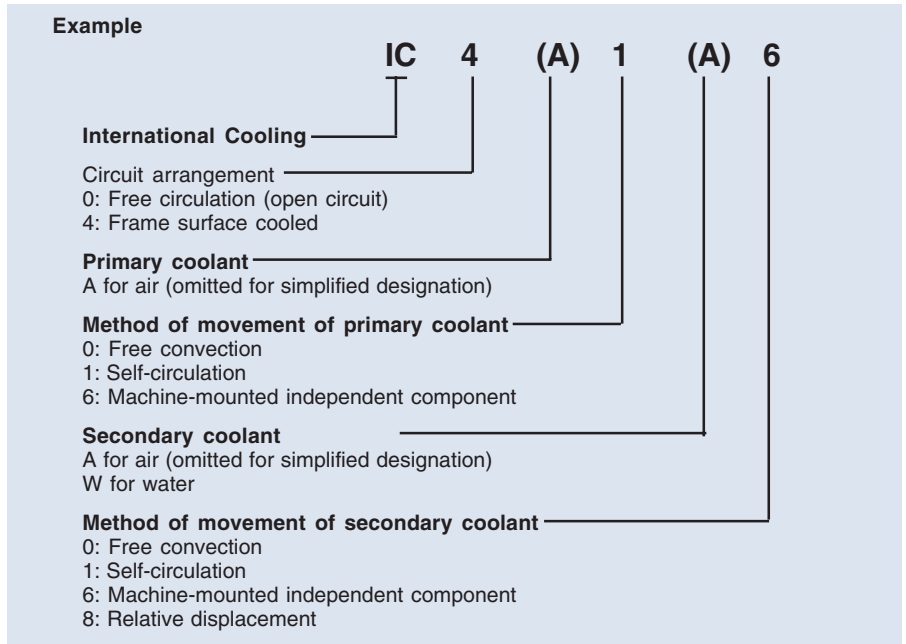

## Degrees of protection: IP code/IK code

Classification of degrees of protection provided by enclosures of rotating machines are refers to:

- Standard IEC 60034-5 or EN 60529 for IP code
- Standard EN 50102 for IK code

### IP protection:

Protection of persons against getting in contact with (or approaching) live parts and against contact with moving parts inside the enclosure.

Also protection of the machine against ingress of solid foreign objects. Protection of machines against the harmful effects due to the ingress of water

### IK code :

Classification of degrees of protection provided by enclosure for motors against external mechanical impacts.

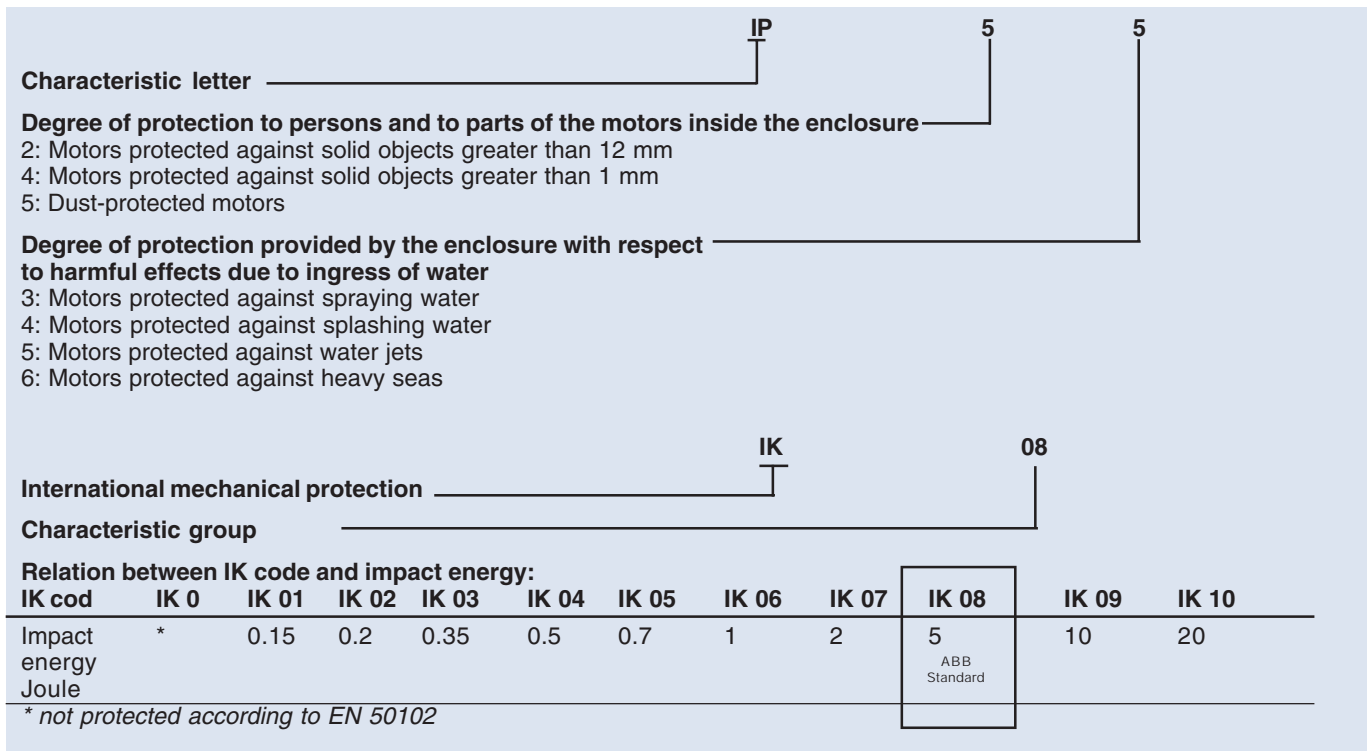

# Insulation

ABB uses class F insulation systems, which, with temperature rise B, is the most common requirement among industry today.

The use of Class F insulation with Class B temperature rise gives ABB products a 25° C safety margin. This can be used to increase the loading by up to 12 per cent for limited periods, to operate at higher ambient temperatures or altitudes, or with greater voltage and frequency tolerances. It can also be used to extend insulation life. For instance, a 10 K temperature reduction will extend the insulation life.

## Class F insulation system

- Max ambient temperature 40° C
- Max permissible temperature rise 105 K
- Hotspot temperature margin + 10 K

## Class B rise

- Max ambient temperature 40° C
- Max permissible temperature rise 80 K
- Hotspot temperature margin + 10 K

## Insulation system temperature class

- Class F 155° C
- Class B 130° C
- Class H 180° C

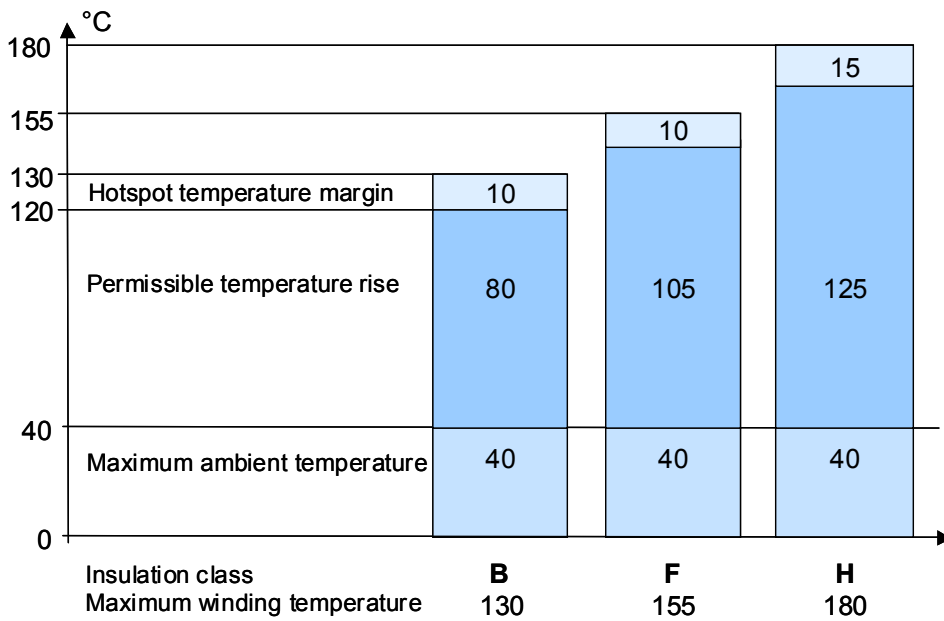

*Safety margins per insulation class*



# Frequency converter drives

Squirrel cage induction motors offer excellent availability, reliability and efficiency. With a frequency converter – a variable speed drive (VSD) – the motor will deliver even better value. A variable speed drive motor can be started softly with low starting current, and the speed can be controlled and adjusted to suit the application demand without steps over a wide range. Also the use of a frequency converter together with a squirrel cage motor usually leads to remarkable energy and environmental savings.

However, all motors are not suitable for variable speed drive. There are several points that have to be taken into account in the design and selection of the motor, if it is intended for variable speed operation.

Within the General purpose motor range ABB offers motors designed for both Direct On Line (DOL) and variable speed applications.

For more demanding applications the use of ABB Process performance motors is recommended.

The following points must be taken into account, when selecting a motor to a variable speed drive:

## 1. Dimensioning

The voltage (or current) fed by the frequency converter is not purely sinusoidal. This may increase the losses, vibration, and noise of the motor. Furthermore, a change in the distribution of the losses may affect the motor temperature balance and lead to an increase in the temperature of the bearings. In each case, the motor must be correctly sized according to the instructions supplied with the selected frequency converter.

When using ABB converters, please use ABB's DriveSize dimensioning programme or the loadability curves of the corresponding converter type for sizing the motors. The loadability curve for applicable General purpose motors used with ABB's ACS 600- and ACS 800- frequency converters can be found in figure 3.

## 2. Speed range

In a frequency converter drive, the actual operating speed of the motor may deviate considerably from its nominal speed (i.e. the speed stamped on the rating plate).

For higher speeds, ensure that the highest permissible rotational speed of the motor or the critical speed of the entire equipment is not exceeded. When high speed operation exceeds the nominal speed of the motor, the following points should be checked:

- Maximum torque of the motor
- Bearing construction
- Lubrication
- Balancing
- Critical speeds
- Shaft seals

- Ventilation
- Fan noise

Guideline values of maximum speeds for M3AA motors within the General purpose motor range are described in figure 1 below. Exact values are available on request.

Figure 1. Guideline values of maximum speeds for General purpose motor in aluminium frame:

Motor size	Speed r/min	
	2-pole	4-pole
M3AA 90-100	6000	6000
M3AA 112-200	4500	4500
M3AA 225-280	3600	3600

At low speed operation the motor's ventilation fan loses its cooling capacity, which causes a higher temperature rise in the motor and in the bearings. A separate constant speed fan can be used to increase cooling capacity and loadability at low speed. It is also important to check the performance of the grease at low speeds.

## 3. Lubrication

Variable speed operation affects on the bearing temperature, which must be taken into account when selecting the lubrication method and grease type. For example the life time of sealed bearings can be remarkably shorter than in direct on line operation. More information can be found from product specific sections of this catalogue and from ABB's Low Voltage Motors Manual.

## 4. Insulation protection

Frequency converter supply causes higher voltage stresses at the windings of the motor than the sinusoidal supply. Thus, the insulation system and possible filters must be selected according to the used voltage, cable length and converter type.

When using ABB's low voltage frequency converters, selection criterias mentioned in figure 2 must be followed.

## 5. Bearing currents

Bearing voltages and currents must be avoided in all motors. Assuming the use of a standard ABB Single drive, with IGBT components and a 6-pulse diode supply unit, insulated bearings and/or properly dimensioned filters at the converter output must be used according to the instructions in figure 2. (For other alternatives and converter types, please contact ABB.) When ordering, clearly state which alternative will be used.

For more information about bearing currents and voltages, please contact ABB.

## 6. Cabling, grounding and EMC

The use of a frequency converter puts higher demands on the cabling and grounding of the drive system. The motor must be cabled by using shielded symmetrical cables and cable glands providing 360° bonding (also called EMC-glands). For motors up to 30 kW unsymmetrical cables can be used, but shielded cables are always recommended.

More information about grounding and cabling of a variable speed drive can be found from the manual

“Grounding and cabling of the drive system” (Code: 3AFY 61201998 R0125 REV A) and the ABB’s Low Voltage Motors Manual.

For fulfilling the EMC requirements, special EMC cable(s) must be used in addition to the correct cable gland mounting, with special, extra earthing pieces. Please refer to the manuals of the frequency converter.

### Validity

Measures mentioned in Figure 2 apply to the applicable motors within the General motors range (not high-output versions) with a ABB's single drives, based on IGBT components and using 6-pulse diode supply unit. For other alternatives and converter types, please contact ABB.

Figure 2. Selection rules for insulation and filtering in variable speed drives

	Motor nominal power $P_N$ or frame size		
	$P_N < 100 \text{ kW}$	$P_N \geq 100 \text{ kW or } \geq \text{IEC 315}$	$P_N \geq 350 \text{ kW } \geq \text{IEC 400}$
$U_N \leq 500 \text{ V}$	Standard motor	Standard motor + Insulated N-bearing	Standard motor + Insulated N-bearing + Common mode filter
$U_N \leq 600 \text{ V}$	Standard motor + dU/dt-filter <b>OR</b> Reinforced insulation	Standard motor + dU/dt-filter (reactor) + Insulated N-bearing <b>OR</b> Reinforced insulation + Insulated N-bearing	Standard motor + Insulated N-bearing + dU/dt-filter + Light Common mode filter <b>OR</b> Reinforced insulation + Insulated N-bearing + Common mode filter
$U_N \leq 690 \text{ V}$	Reinforced insulation + dU/dt-filter	Reinforced insulation + dU/dt-filter (reactor) + Insulated N-bearing	Reinforced insulation + Insulated N-bearing + dU/dt-filter + Light common mode filter

### dU/dt filter (reactor)

Series reactor. DU/dt -filter decreases the changing rate of the phase and main voltages and thus reduces voltage stresses in the windings. DU/dt -filters also decrease so-called common mode currents and the risk of bearing currents. DU/dt -filters are designed so that dU/dt -rate of main voltages at motor terminals is less than 1 kV/s. See ABB manual, ACS 600 dU/dt -filter selection guide.

### Common mode and light common mode filters

Common mode filters are made of toroidal cores installed around motor cables. These filters reduce so-called common mode

currents in VSD applications and thus decrease the risk of bearing currents. Common mode filters do not significantly affect the phase or main voltages on the motor terminals.

### Insulated Bearings

Bearings with insulated inner or outer races are used as the standard solution. So-called hybrid bearings, i.e. bearings with non-conductive ceramic balls, can also be used in special applications. More information for spare part selection is available on request.

Figure 3. Motor loadability with ACS 600 and ACS 800, Field weakening point 50 Hz.

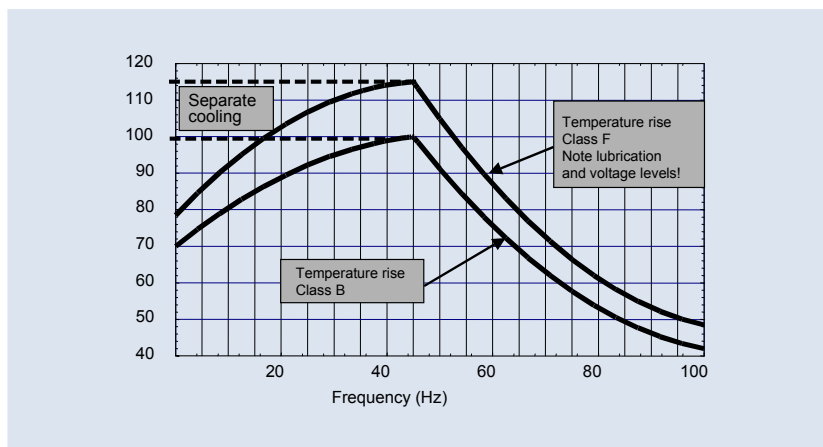



# Drive<sup>IT</sup> General Purpose Aluminium Motors

Totally enclosed squirrel cage three phase low voltage motors,  
Sizes 56 - 280, 0.06 to 95 kW

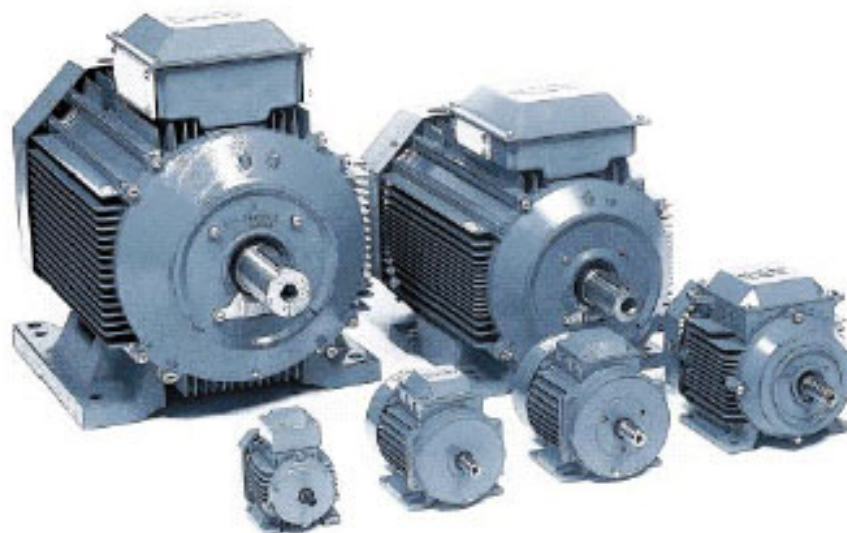

2

<b>Mechanical design.....</b>	<b>12</b>
<b>Rating plates.....</b>	<b>22</b>
<b>Ordering information.....</b>	<b>23</b>
<b>Technical data.....</b>	<b>24</b>
<b>Variant codes.....</b>	<b>46</b>
<b>Dimension drawings.....</b>	<b>53</b>
<b>Accessories.....</b>	<b>74</b>
<b>Aluminium motors in brief.....</b>	<b>76</b>

# Mechanical design

## Stator

Stator framework, bearing shields and feet are made of an extra corrosion resistant aluminium alloy with low copper content with the following exceptions: M2AA 180-250 and M3AA 250 SMA-2 basic version, have cast iron feet.

M3AA 280 has feet and D-end shield of cast iron. M3AA 250 SMB 2-pole, high output version, as well as M3AA 280 2-pole have cast iron feet and bearing shields.

The flange bearing shields of sizes 180 to 280 are made of cast iron.

## Drain holes

Motors that will be operated in very humid or wet environments and especially under intermittent duty should be provided with drain holes. The appropriate IM designation, such as IM 3031, is specified on the basis of the method of mounting the motor.

Motors are provided with closable plastic plugs in the drain holes (see diagram below). The plugs will be open on delivery. When mounting the motors it should be ensured that the drain holes face downwards. In the case of vertical mounting, the upper plug must be

hammered home completely. In very dusty environments both plugs should be hammered home.

Sizes 56 to 63 are supplied as standard with drain holes on D-end while sizes 71 to 280 are supplied with drain holes both on D-end and N-end.

When mounting arrangement differs from foot mounted IM B3, please mention variant code 066 when ordering.

See variant codes 065, 066 and 076 under the heading "Drain holes".

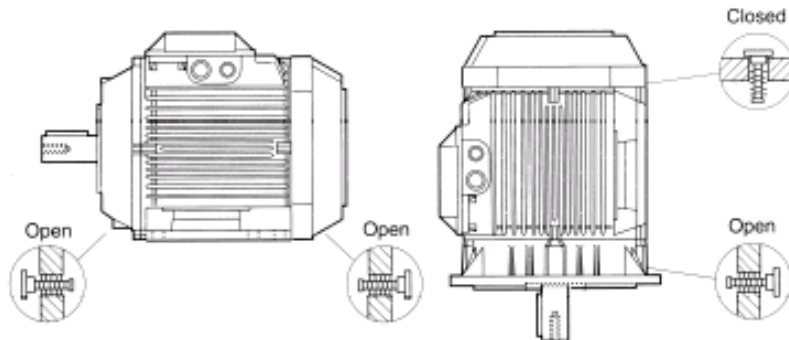

# Terminal box

## Sizes 56 to 180 and M2AA 200

The terminal box is made of aluminium alloy and is located on top of the stator. The lower part of the box is integrated with the stator. It is provided with 2 knockout openings on each side. Sizes 160-180 also have a third smaller opening. Cable glands are not included.

## Sizes 200 to 280, except M2AA 200

The terminal box and cover are made of deep drawn steel and mounted on top of the stator. The box is bolted to the stator and is not rotatable. The size of the box is the same for all motors.

In the basic design the terminal box is provided with two FL 13 flange openings, one on each side. The opening on the right side, seen from the D-end, is supplied with a flange with two holes for M40 cable glands. On delivery the holes are sealed by means of plastic plugs. Cable

glands are not supplied. The opening on the other side is provided with a cover flange.

The motors can also be provided with an extra large terminal box, standard for voltage code S and frame size 280. See variant code 019 under the heading "Terminal box". This will increase the dimension HD by 32 mm. The box is supplied with two FL 21 openings. The right opening is provided with a flange with two holes for M63 cable glands. The holes are sealed by means of plastic plugs. Cable glands are not supplied. The opening on the other side is provided with a cover flange. The box can also be provided with an FL 13 opening towards the N-end.

When new motors are manufactured the terminal box can be mounted on the left or the right side. See variant codes 021 and 180 under the heading "Terminal box".

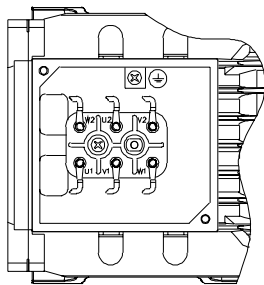

Terminal box size 56-80.

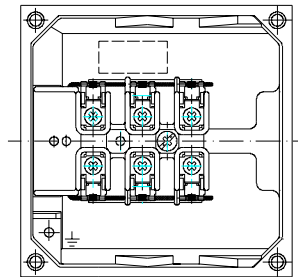

Terminal box size 90-100.

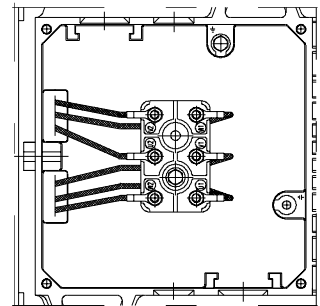

Terminal box size 112-132.

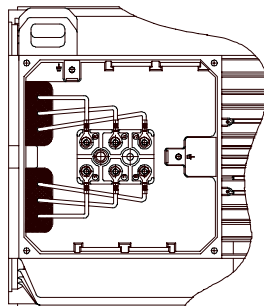

Terminal box size 160-180 and M2AA 200.

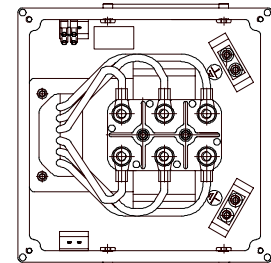

Terminal box size 200-280, except M2AA 200.

## Connections

The terminal block is provided with 6 terminals for connecting Cu-cable. The terminals are marked in accordance with IEC 60034-8.

### Connection openings

Motor size	Opening	Metric cable entry	Method of connection	Terminal bolt size	Maximum connectable Cu-cable area, mm <sup>2</sup>
56-63	Knock-out opening	1 x M16 x 1.5 1 x Pg 11	Screw terminal	M4	2.5
71-80	Knock-out opening	2 x M20 x 1.5 2 x Pg 16	Screw terminal	M4	4
90-100	Knock-out opening	4 x M25 x 1.5	Screw terminal	M4	6
112-132	Knock-out opening	2 x (M25 + M20)	Cable lug	M5	10
160-180	Knock-out opening	2 x (2 x M40 + M16)	Cable lug	M6	35
200 <sup>1)</sup>	Knock-out opening	2 x (2 x M40 + M16)	Cable lug	M6	35
200-250 <sup>2)</sup>	2 x FL 13	1 x (2 x M40 + M16)	Cable lug	M10	70
280	2 x FL 21	1 x (2 x M63 + M16)	Cable lug	M10	70

<sup>1)</sup> M2AA

<sup>2)</sup> M2AA 200 excluded

# Bearings

The motors are provided with bearings according to the tables below.

Greater axial forces can be tolerated if the motors are provided with angular contact ball bearings. Note that in

such cases the axial force must only operate in one direction.

Motor versions with roller bearings tolerate greater radial forces.

## Basic version with deep groove ball bearings

Basic design motors		
Motor size	Foot- and flange-mounted motor	
	D-end	N-end
56	6201-2Z/C3	6201-2Z/C3
63	6202-2Z/C3	6201-2Z/C3
71	6203-2Z/C3	6202-2Z/C3
80	6204-2Z/C3	6203-2Z/C3
90	6205-2Z/C3	6204-2Z/C3
100	6306-2Z/C3	6205-2Z/C3
112 <sup>2)</sup> short	6206-2Z/C3	6205-2Z/C3
112 <sup>2)</sup> long	6206-2Z/C3	6206-2Z/C3
132 <sup>2)</sup> short	6208-2Z/C3	6206-2Z/C3
132 <sup>2)</sup> long	6208-2Z/C3	6208-2Z/C3
160	6309-2Z/C3	6209-2Z/C3
180	6310-2Z/C3	6209-2Z/C3
200 <sup>1)</sup>	6312-2Z/C3	6209-2Z/C3
200	6312/C3	6210/C3
225 <sup>1)</sup>	6313/C3	6210/C3
225	6313/C3	6212/C3
250 <sup>1)</sup>	6315/C3	6212/C3
250	6315/C3	6213/C3
280 2-pole	6315/C3	6213/C3
280 4-8 pole	6316/C3	6213/C3

<sup>1)</sup> M2AA

<sup>2)</sup> short: M2AA 112: M-2,M-4; M2AA 132: SA-2, SB-2, S-4, M-4  
M3AA 112: M-6, M-8; M3AA 132: SA-2, S-4, S-6, MA-6, MB-6, S-8, M-8, S-two-speed

long: remaining versions

## Alternative designs:

### Version with roller bearings

It is recommended to use roller bearings in belt drives for motor sizes 160 - 280.

See variant code 037 under the heading "Bearings and lubrication".

Motor size	D-end	N-end
90	NU 205	–
100	NU 306	–
160	NU 309 ECP	–
180	NU 310 ECP	–
200	NU 312 ECP	–
225	NU 313 ECP	–
250	NU 315 ECP	–
280 2-pole	NU 315 ECP	–
280 4-8 pole	NU 316 ECP	–

### Version with angular contact ball bearings

See variant codes 058 and 059 under the heading "Bearings and lubrication".

Motor size	D-end 058	N-end 059
90	7205 B	7204 B
100	7306 B	7205 B
112 <sup>2)</sup> short	7206 BE	7205 BE
112 <sup>2)</sup> long	7206 BE	7206 BE
132 <sup>2)</sup> short	7208 BE	7206 BE
132 <sup>2)</sup> long	7208 BE	7208 BE
160 <sup>1)</sup>	7309 BE	7209 BE
180 <sup>1)</sup>	7310 BE	7209 BE
200 <sup>1)</sup>	7312 BE	7210 BE
225 <sup>1)</sup>	7313 BE	7212 BE
250 <sup>1)</sup>	7315 BE	7213 BE
280 2-pole	7315 BE	7213 BE
280 4-8 pole	7316 BE	7213 BE

<sup>1)</sup> M2AA on request

<sup>2)</sup> short: M2AA 112: M-2,M-4; M2AA 132: SA-2, SB-2, S-4, M-4  
M3AA 112: M-6, M-8; M3AA 132: SA-2, S-4, S-6, MA-6, MB-6, S-8, M-8, S-two-speed

long: remaining versions

## Transport locking

Motors provided with roller bearings or angular contact ball bearings are fitted with a transport lock to prevent damage to the bearings, due to vibration, during transport.

## Axially-locked bearings

The table below shows which of the motor's bearings are axially locked in the bearing seat. In motor sizes 56 to 80 the locking is done by an inner bearing circlip, in motor sizes 90 to 280 by an inner bearing cover.

See also variant code 042 under the heading "Bearings and lubrication".

Motor size	Foot-mounted motors	Flange-mounted motors	
		Large flange	Small flange
56-63	On request at D-end	On request at D-end	On request at D-end
71-80	On request at D-end	D-end	On request at D-end
90-100	D-end <sup>1)</sup>	D-end <sup>1)</sup>	D-end <sup>1)</sup>
112-132	D-end <sup>1)</sup>	D-end	D-end
160-280	D-end	D-end	–

<sup>1)</sup> A spring-washer at the N-end presses the rotor toward the D-end.

## Lubrication

The motors are delivered with bearing grease for use at normal temperatures in dry or humid environments. The motors are lubricated for ambient temperatures 40°C and in some cases even above 40°C, see table 1 next page.

Motor sizes 63-180 and M2AA 200 are provided with shielded bearings. On request, motor sizes 90 to 180 and M2AA 200 are provided with grease nipples for regreasing, see variant code 041 under the heading "Bearings and lubrications".

Motor sizes 200-280, except M2AA 200, are provided with grease nipples for re-greasing as standard.

The lubrication interval  $L_1$ , suitable for relubricated bearings, is defined as the number of operating hours after which 99 per cent of the bearings are adequately lubricated.

Lubrication intervals and grease quantities are specified on a plate on the motor as well as in the manual supplied with the motor.

The grease lifetime  $L_{10}$ , suitable for permanent lubricated bearings, is defined as the number of operating hours after which 90 per cent of the bearings are adequately lubricated. 50 per cent of the bearings achieve two times this figure. Maximum lifetime, however, should be regarded as 40000 hours.

In case of high ambient temperatures the shaft loads must be reduced compared to permissible loadings in the table (see pages 18 to 21), please contact ABB.

Table 1: Grease lifetime  $L_{10}$  in deep groove ball bearings of type 2Z in horizontally mounted motors in continuous running duty.

Motor	r/min	Ambient temperature and rated output											
		25 °C		40 °C		50 °C		60 °C		70 °C		80 °C	
		Basic	High	Basic	High	Basic	High	Basic	High	Basic	High	Basic	High
56-63	3000	40000	40000	40000	40000	40000	40000	40000	40000	40000	40000	40000	27000
	1500												37000
	1000												
	750												32000
71	3000	40000	40000	40000	40000	40000	40000	40000	40000	40000	40000	40000	27000
	1500												37000
	1000												
	750												32000
80	3000	40000	40000	40000	40000	40000	40000	40000	30000	24000	19000	40000	
	1500								29000				
	1000								40000				
	750								32000				
90	3000	40000	40000	40000	40000	40000	40000	40000	30000	24000	19000	15000	40000
	1500								24000				
	1000								36000				
	750								31000				
100	3000	40000	40000	40000	40000	40000	40000	40000	35000	22000	27000	14000	17000
	1500								21000				
	1000								33000				
	750								40000				
112	3000	40000	40000	40000	40000	40000	40000	40000	30000	26000	17000		
	1500								27000				
	1000								40000				
	750								35000				
132	3000	40000	40000	40000	40000	40000	40000	40000	24000	23000			
	1500								22000				
	1000								30000				
	750								40000				
160	3000	40000	40000	40000	40000	40000	40000	40000	31000	26000	17000	14000	9000
	1500								25000				
	1000								25000				
	750								30000				
180	3000	40000	38000	38000	34000	34000	29000	20000	15000	10000	8000		
	1500		40000	40000	40000	40000	40000	40000	40000	20000	30000		
	1000												
	750												
M2AA	3000	27000		27000		20000		11000					
200	1500	40000		38000		38000		22000					

In vertically mounted motors, the grease lifetime is half the figures above.

For applications corresponding to the empty cells in the table, please contact ABB. These applications can imply reduced lifetime for bearings and winding.

## Lubrication intervals

ABB follows the L1-principle in defining lubrication interval. That means that 99% of the motors are sure to make the interval time. The lubrication intervals can also be calculated according to the L10-principle, which are normally doubled

compared to L1-values. Values available from ABB at request.

The table below gives lubrication intervals according to the L1-principle for different speeds. The values are valid for horizontal mounted motors

(B3), with about 80°C bearing temperature and using good quality grease with lithium complex soap and with mineral or PAO-oil.

For more information, see ABB's Low Voltage Motors Manual.

Frame size	Amount of grease g	3600 r/min	3000 r/min	1800 r/min	1500 r/min	1000 r/min	500-750 r/min
------------	--------------------	------------	------------	------------	------------	------------	---------------

**Ball bearings:** lubrication intervals in duty hours

180	30	6000	8000	13500	16000	20000	23000
200	40	4000	6000	11000	13000	17000	21000
225	50	3000	5000	10000	12500	16500	20000
250	60	2500	4000	9000	11500	15000	18000
280	35	2000	3500	-	-	-	-
280	70	-	-	8000	10500	14000	17000

Frame size	Amount of grease g	3600 r/min	3000 r/min	1800 r/min	1500 r/min	1000 r/min	500-750 r/min
------------	--------------------	------------	------------	------------	------------	------------	---------------

**Roller bearings:** lubrication intervals in duty hours

180	30	3000	4000	7000	8000	10000	11500
200	40	2000	3000	5500	6500	8500	10500
225	50	1500	2500	5000	6000	8000	10000
250	60	1300	2200	4500	5700	7500	9000
280	35	1000	1800	-	-	-	-
280	70	-	-	4000	5300	7000	8500



# Permissible loading on shaft

## Pulley diameter

When the desired bearing life has been determined the minimum permissible pulley diameter can be calculated with FR, according to the formula:

$$D = \frac{1.9 \cdot 10^7 \cdot K \cdot P}{n \cdot F_R}$$

## Bearing life

The nominal life is defined as the number of hours that are attained or exceeded by 90% of identical bearings, in a large test series, under certain specified conditions. 50% of the bearings attain a life of as much as 5 times this figure.

The life of bearings is dependent on various factors such as bearing load, motor speed, operating temperature and the purity of the grease. The permissible radial and axial loading for different motor sizes is shown in the table on the following pages.

The table is valid for 50 Hz. For 60 Hz and/or some other bearing life than specified in the table the values are changed according to the table on the right.

## Permissible radial forces

The table at right shows the permissible radial force in Newton assuming zero axial force.

Permissible loads of simultaneous radial and axial forces will be supplied on request.

The bearing life,  $L_{10}$ , is calculated according to SKF's theory on bearing life  $L_{10_{aah}}$ , which also takes the purity of the grease into consideration. An adequate lubrication is a necessary prerequisite for the table at right.

If the radial force is applied between points  $X_0$  and  $X_{max}$ , the permissible force  $F_R$  can be calculated from the following formula:

$$F_R = F_{X_0} \cdot \frac{X}{E} (F_{X_0} - F_{X_{max}})$$

E = length of shaft extension in basic version.

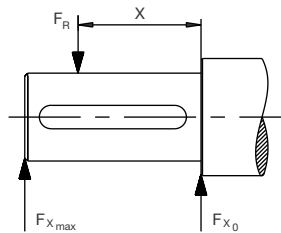

where:

D = diameter of pulley, mm

P = power requirement, kW

n = motor speed, r/min.

K = belt tension factor, dependent on belt type and type of duty. A common value for V-belts is  $K = 2.5$

$F_R$  = permissible radial force according to the tables

The table values assume the occurrence of only radial or axial forces. In the case of simultaneous radial and axial forces information can be supplied on request. It is assumed that the radial force is applied at the end of the motor shaft.

### Permissible force at changed bearing life or supply frequency

Bearing life in hours at		Permissible force, as percentage of value in tables
50 Hz	60 Hz	
25,000	21,000	100% of value for 25,000 hours
40,000	33,000	100% of value for 40,000 hours
63,000	52,000	86% of value for 40,000 hours
80,000	67,000	80% of value for 40,000 hours

Motor size	No. of poles	Length of shaft extension E (mm)	Ball bearings			
			Basic design with deep groove ball bearings			
			25,000 hrs $FX_0$ (N)	$FX_{max}$ (N)	40,000 hrs $FX_0$ (N)	$FX_{max}$ (N)
56	2	20	240	200	260	200
	4	20	300	200	280	200
	6	20	340	280	340	280
	8	20	340	280	340	280
63	2	23	490	400	490	400
	4	23	490	400	490	400
	8	23	490	400	490	400
71	2	30	680	570	680	570
	4	30	680	570	680	570
	6	30	680	570	680	570
	8	30	680	570	680	570
80	2	40	630	750	930	750
	4	40	930	750	930	750
	6	40	930	750	930	750
	8	40	930	750	930	750
90	2	50	1010	810	1010	810
	4	50	1010	810	1010	810
	6	50	1010	810	1010	810
	8	50	1010	810	1010	810
100 <sup>1)</sup>	2	60	2280	1800	2280	1800
	4	60	2280	1800	2280	1800
	6	60	2280	1800	2280	1800
	8	60	2280	1800	2280	1800

<sup>1)</sup> Basic design with 63-series bearings at the D-end.

## Permissible radial forces

### Motor sizes 112 to 180

Motor size	No. of poles	Length of shaft extension E (mm)	Ball bearings				Alternative design with 63-series bearings				Roller bearings			
			Basic design with deep groove ball bearings				Alternative design with roller bearings				Alternative design with roller bearings			
			25,000 hrs		40,000 hrs		25,000 hrs		40,000 hrs		25,000 hrs		40,000 hrs	
		FX <sub>0</sub> (N)	FX <sub>max</sub> (N)	FX <sub>0</sub> (N)	FX <sub>max</sub> (N)	FX <sub>0</sub> (N)	FX <sub>max</sub> (N)	FX <sub>0</sub> (N)	FX <sub>max</sub> (N)	FX <sub>0</sub> (N)	FX <sub>max</sub> (N)	FX <sub>0</sub> (N)	FX <sub>max</sub> (N)	
<b>112 M</b>	2	60	1420	1800	1280	1620	1700	2160	1700	2160				
	4	60	1410	1790	1250	1590	1700	2160	1700	2160				
	6	60	1510	1910	1340	1700	1700	2160	1700	2160				
	8	60	1530	1940	1360	1720	1700	2160	1700	2160				
<b>112 MB</b>	2	60	1470	1820	1330	1640	1700	2100	1700	2100				
	4	60	1430	1770	1260	1560	1700	2100	1700	2100				
	6	60	1520	1880	1340	1650	1700	2100	1700	2100				
	8	60	1560	1930	1370	1690	1700	2100	1700	2100				
<b>132 SA</b>	2	80	2360	3020	2140	2740	3180	4070	2870	3670				
<b>132 SB</b>	2	80	2360	3020	2130	2730	3170	4060	2870	3670				
<b>132 SC</b>	2	80	2430	3030	2200	2750	3200	3990	2960	3690				
<b>132 S</b>	4	80	2440	3120	2180	2790	3200	4090	2990	3830				
<b>132 M</b>	4	80	2410	3080	2150	2750	3200	4100	2950	3780				
<b>132 MB</b>	4	80	2440	3050	2170	2710	3200	3990	3000	3740				
<b>132 S</b>	6	80	2560	3280	2270	2910	3200	4100	3120	3990				
<b>132 MA</b>	6	80	2530	3240	2250	2880	3200	4100	3100	3970				
<b>132 MB</b>	6	80	2500	3200	2220	2840	3200	4100	3070	3930				
<b>132 MC</b>	6	80	2510	3010	2220	2660	3200	3840	3090	3700				
<b>132 S</b>	8	80	2630	3370	2330	2980	3200	4100	3200	4100				
<b>132 M</b>	8	80	2590	3310	2300	2940	3200	4100	3170	4060				
<b>132 MB</b>	8	80	2630	3280	2330	2910	3200	3990	3200	3990				
<b>160 MA</b>	2	110	3500	4470	3500	4470					3500	4470	3500	4470
	8	110	3500	4470	3500	4470					3500	4470	3500	4470
<b>160 M</b>	2	110	3500	4470	3500	4470					3500	4470	3500	4470
	4	110	3500	4470	3500	4470					3500	4470	3500	4470
	6	110	3500	4470	3500	4470					3500	4470	3500	4470
	8	110	3500	4470	3500	4470					3500	4470	3500	4470
	8	110	3500	4470	3500	4470					3500	4470	3500	4470
<b>160 L</b>	2	110	3500	4470	3500	4470					3500	4470	3500	4470
	4	110	3500	4470	3500	4470					3500	4470	3500	4470
	6	110	3500	4470	3500	4470					3500	4470	3500	4470
	8	110	3500	4380	3500	4380					3500	4380	3500	4380
<b>160 LB</b>	2	110	3500	4470	3500	4470					3500	4470	3500	4470
	4	110	3500	4470	3500	4470					3500	4470	3500	4470
	6	110	3500	4380	3500	4380					3500	4380	3500	4380
	8	110	3500	4380	3500	4380					3500	4380	3500	4380
<b>180 M</b>	2	110	5550	6900	5110	6360					5900	7338	5900	7340
	4	110	5710	7100	5200	6470					5900	7338	5900	7340

## Permissible radial forces

### Motor sizes 180 to 280

Motor size	No. of poles	Length of shaft extension E (mm)	Ball bearings Basic design with deep groove ball bearings				Roller bearings Alternative design with roller bearings			
			25,000 hrs		40,000 hrs		25,000 hrs		40,000 hrs	
			FX <sub>0</sub> (N)	FX <sub>max</sub> (N)	FX <sub>0</sub> (N)	FX <sub>max</sub> (N)	FX <sub>0</sub> (N)	FX <sub>max</sub> (N)	FX <sub>0</sub> (N)	FX <sub>max</sub> (N)
<b>180 L</b>	4	110	5670	7050	5150	6410	5900	7340	5900	7340
	6	110	5900	7340	5500	6840	5900	7340	5900	7340
	8	110	5900	7340	5570	6930	5900	7340	5900	7340
<b>180 LB</b>	2	110	5550	6900	5110	6360	5900	7340	5900	7340
	4	110	5670	6990	5150	6350	5900	7280	5900	7280
	6	110	5900	7280	5500	6780	5900	7280	5900	7280
<b>M2AA 200</b>	8	110	5900	7280	5570	6870	5900	7280	5900	7280
	2	110	5800	7000	5200	6300	7500	9100	6700	8100
	4	110	5500	6700	4900	5900	7800	9500	7100	8600
<b>M3AA 200 MLA</b>	2	110	4070	4940	3600	4370	7790	9460	7790	9460
	4	110	4410	5360	3860	4690	7790	9460	7790	9460
	6	110	4600	5590	3990	4850	7790	9460	7790	9460
<b>M3AA 200 MLB</b>	8	110	4680	5680	4040	4910	7790	9460	7790	9460
	2	110	4060	4930	3590	4360	7790	9460	7790	9460
	4	110	4360	5290	3810	4630	7790	9460	7790	9460
<b>M3AA 200 MLC</b>	6	110	4540	5510	3940	4780	7790	9460	7790	9460
	8	110	4670	5670	4030	4890	7790	9460	7790	9460
	2	110	4050	4920	3590	4360	7790	9460	7790	9460
<b>225 SMA</b>	6	110	4430	5380	3820	4640	7790	9460	7790	9460
	4	140	4930	5830	4320	5100	8300	9810	8300	9810
<b>225 SMB</b>	8	140	5420	6400	4700	5550	8300	9810	8300	9810
	2	110	4530	5400	4010	4780	8900	10600	8900	10600
<b>225 SMC</b>	4	140	4870	5750	4260	5030	8300	9810	8300	9810
	6	140	5080	6000	4400	5200	8300	9810	8300	9810
	8	140	5350	6320	4630	5470	8300	9810	8300	9810
<b>250 SMA</b>	2	110	4510	5370	3990	4750	8900	10600	8900	10600
	4	140	4840	5720	4230	5000	8300	9810	8300	9810
	6	140	5020	5930	4340	5130	8300	9810	8300	9810
<b>250 SMB</b>	8	140	5230	6180	4500	5320	8300	9810	8300	9810
	2	140	5620	6970	4980	6180	9100	11290	9100	11290
	4	140	6200	7693	5440	6750	11550	14330	11550	14330
<b>280 SMA</b>	6	140	6430	7978	5590	6940	11550	14330	11550	14330
	8	140	6650	8250	5760	7150	11500	14330	11550	14330
	2	140	5610	6960	4960	6150	9100	11290	9100	11290
<b>280 SMB</b>	4	140	6140	7620	5380	6680	11550	14330	11550	14330
	6	140	6400	7940	5560	6900	11550	14330	11550	14330
	8	140	6590	8180	5700	7070	11550	14330	11550	14330
<b>280 SMA</b>	2	140	5400	6650	4750	5850	12400	15260	11200	13790
	4	140	6300	7750	5600	6890	15000	18460	13450	16560
	6	140	7100	8810	6250	7760	17000	21090	15200	18860
<b>280 SMB</b>	8	140	7250	9000	6350	7880	17600	21840	15600	19360
	2	140	5250	6460	4650	5720	12400	15260	11200	13790
	4	140	6100	7510	5350	6590	14500	17850	13050	16060

## Permissible axial forces

The following tables give the permissible axial forces in Newton, assuming zero radial force. The values are based on normal conditions at 50 Hz with standard bearings and calculated bearing lives of 20,000 and 40,000 hours.

At 60 Hz the values are to be reduced by 10%.

For two-speed motors, the values are to be based on the higher speed. The permissible loads of simultaneous radial and axial forces will be supplied on request.

Given axial forces  $F_{AD}$ , assumes D-bearing locked by means of locking ring.

### Mounting arrangement IM B3



Motor size	20,000 hours								40,000 hours							
	2-pole		4-pole		6-pole		8-pole		2-pole		4-pole		6-pole		8-pole	
	$F_{AD}$ N	$F_{AZ}$ N	$F_{AD}$ N	$F_{AZ}$ N	$F_{AD}$ N	$F_{AZ}$ N	$F_{AD}$ N	$F_{AZ}$ N	$F_{AD}$ N	$F_{AZ}$ N	$F_{AD}$ N	$F_{AZ}$ N	$F_{AD}$ N	$F_{AZ}$ N	$F_{AD}$ N	$F_{AZ}$ N
<b>56</b>	470	230	520	280	540	300	540	300	430	190	470	230	480	240	480	240
<b>63</b>	790	390	865	465	-	-	895	495	720	320	780	380	-	-	895	495
<b>71</b>	985	485	1070	570	1135	635	1130	630	900	400	970	470	1020	520	1015	515
<b>80</b>	1305	705	1420	820	1505	905	1540	940	1185	585	1285	685	1350	750	1375	775
<b>90</b>	1360	930	1490	1070	1590	1165	1635	1210	1225	800	1335	915	1415	990	1450	1025
<b>100</b>	2805	1945	3075	2215	3260	2400	3355	2495	2540	1680	2760	1900	2910	2050	2985	2125
<b>112 M</b>	1500	1500	1600	1600	1730	1730	1750	1750	1320	1320	1390	1390	1500	1500	1510	1510
<b>112 MB</b>	1530	1530	1600	1600	1720	1720	1760	1760	1340	1340	1390	1390	1490	1490	1520	1520
<b>132 SA</b>	2570	2570	-	-	-	-	-	-	2260	2260	-	-	-	-	-	-
<b>132 SB</b>	2570	2570	-	-	-	-	-	-	2260	2260	-	-	-	-	-	-
<b>132 SC</b>	2520	2520	-	-	-	-	-	-	2210	2210	-	-	-	-	-	-
<b>132 S</b>	-	-	2770	2770	2950	2950	3040	3040	-	-	2440	2440	2580	2580	2650	2650
<b>132 M</b>	-	-	2750	2750	-	-	3020	3020	-	-	2420	2420	-	-	2630	2630
<b>132 MA</b>	-	-	-	-	2940	2940	-	-	-	-	-	-	2570	2570	-	-
<b>132 MB</b>	-	-	2680	2680	2910	2910	2940	2940	-	-	2340	2340	2550	2550	2560	2560
<b>132 MC</b>	-	-	-	-	2830	2830	-	-	-	-	-	-	2460	2460	-	-
<b>160 MA</b>	4730	4730	-	-	-	-	5240	5240	4220	4220	-	-	-	-	4640	4640
<b>160 M</b>	4730	4730	5230	5230	5220	5220	5220	5220	4220	4220	4640	4640	4630	4630	4630	4630
<b>160 L</b>	5240	5240	5220	5220	5050	5050	4720	4720	4650	4650	4630	4630	4470	4470	4740	4740
<b>160 LB</b>	5240	5240	5050	5050	4720	4720	4720	4720	4650	4650	4470	4470	4740	4740	4740	4740
<b>180 M</b>	4660	4660	4950	4950	-	-	-	-	4250	4250	4500	4500	-	-	-	-
<b>180 L</b>	-	-	4870	4870	5200	5200	5370	5370	-	-	4390	4390	4710	4710	4850	4850
<b>180 LB</b>	4660	4660	4870	4870	5200	5200	5370	5370	4250	4250	4390	4390	4710	4710	4850	4850
<b>200 MLA</b>	3050	3050	3850	3850	4400	4400	4850	4850	2430	2430	3050	3050	3500	3500	3850	3850
<b>200 MLB</b>	3050	3050	3850	3850	4400	4400	4850	4850	2430	2430	3050	3050	3500	3500	3850	3850
<b>200 MLC</b>	3050	3050	-	-	4400	4400	-	-	2430	2430	-	-	3500	3500	-	-
<b>225 SMA</b>	-	-	4340	4340	-	-	5460	5460	-	-	3440	3440	-	-	4340	4340
<b>225 SMB</b>	3440	3440	4340	4340	4960	4960	5460	5460	2730	2730	3440	3440	3940	3940	4340	4340
<b>225 SMC</b>	3440	3440	4340	4340	4960	4960	5460	5460	2730	2730	3440	3440	3940	3940	4340	4340
<b>250 SMA</b>	4180	4180	5260	5260	6020	6020	6630	6630	3320	3320	4180	4180	4780	4780	5260	5260
<b>250 SMB</b>	4180	4180	5260	5260	6020	6020	6630	6630	3320	3320	4180	4180	4780	4780	5260	5260
<b>280 SMA</b>	5000	5000	6200	6200	7100	7100	7350	7350	4500	4500	5400	5400	6250	6250	6500	6500
<b>280 SMB</b>	5000	5000	6100	6100	-	-	-	-	4400	4400	5300	5300	-	-	-	-

## Permissible axial forces

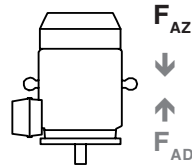

### Mounting arrangement IM V1

Motor size	20,000 hours								40,000 hours							
	2-pole		4-pole		6-pole		8-pole		2-pole		4-pole		6-pole		8-pole	
	F <sub>AD</sub> N	F <sub>AZ</sub> N	F <sub>AD</sub> N	F <sub>AZ</sub> N	F <sub>AD</sub> N	F <sub>AZ</sub> N	F <sub>AD</sub> N	F <sub>AZ</sub> N	F <sub>AD</sub> N	F <sub>AZ</sub> N	F <sub>AD</sub> N	F <sub>AZ</sub> N	F <sub>AD</sub> N	F <sub>AZ</sub> N	F <sub>AD</sub> N	F <sub>AZ</sub> N
56	470	230	520	270	540	290	540	290	430	190	470	230	480	240	480	240
63	790	380	875	455	-	-	905	485	725	310	790	370	-	-	810	390
71	998	470	1085	555	1150	620	1145	615	910	385	985	455	1035	505	1030	500
80	1320	685	1445	790	1530	880	1565	915	1200	565	1310	655	1375	725	1400	750
90	1390	900	1525	1035	1625	1130	1670	1180	1255	770	1370	880	1450	955	1485	990
100	2855	1890	3135	2155	3320	2340	3420	2425	2590	1625	2820	1840	2970	1990	3050	2060
112 M	2290	2170	2490	2330	2680	2510	2770	2590	2030	1910	2190	2030	2350	2180	2410	2230
112 MB	2340	2170	2520	2300	2700	2480	2790	2570	2080	1910	2220	2000	2360	2140	2430	2210
132 SA	3550	3370	-	-	-	-	-	-	3160	2980	-	-	-	-	-	-
132 SB	3560	3360	-	-	-	-	-	-	3170	2970	-	-	-	-	-	-
132 SC	3550	3270	-	-	-	-	-	-	3160	2880	-	-	-	-	-	-
132 S	-	-	3910	3630	4160	3880	4320	3990	-	-	3460	3180	3660	3380	3780	3450
132 M	-	-	3910	3590	-	-	4330	3930	-	-	3450	3130	-	-	3790	3390
132 MA	-	-	-	-	4180	3850	-	-	-	-	-	-	3670	3340	-	-
132 MB	-	-	3880	3460	4180	3780	4260	3840	-	-	3430	3010	3680	3280	3730	3310
132 MC	-	-	-	-	4110	3690	-	-	-	-	-	-	3610	3190	-	-
160 MA	4940	4520	-	-	-	-	5520	4960	4430	4010	-	-	-	-	4920	4360
160 M	4960	4500	5500	4960	5540	4900	5540	4900	4450	3990	4910	4370	4950	4310	4950	4310
160 L	5520	4960	5560	4880	5420	4680	5170	4280	4930	4370	4970	4290	4840	4100	5190	4300
160 LB	5540	4940	5420	4680	5170	4280	5170	4280	4950	4350	4840	4100	5190	4300	5190	4300
180 M	4990	4330	5400	4500	-	-	-	-	4580	3920	4950	4050	-	-	-	-
180 L	-	-	5390	4350	5770	4630	5930	4810	-	-	4910	3870	5280	4140	5410	4290
180 LB	5040	4280	5470	4270	5810	4590	5980	4760	4630	3870	4990	3790	5320	4100	5460	4240
200 MLA	3600	2500	4580	3120	5280	3530	5720	3980	2970	1870	3780	2320	4370	2620	4720	2980
200 MLB	3600	2500	4580	3120	5280	3530	5720	3980	2970	1870	3780	2320	4370	2620	4720	2980
200 MLC	3600	2500	-	-	5280	3530	-	-	2970	1870	-	-	4370	2620	-	-
225 SMA	-	-	5230	3440	-	-	6530	4400	-	-	4330	2550	-	-	5400	3270
225 SMB	4140	2740	5230	3440	6030	3900	6530	4400	3430	2030	4330	2550	5010	2870	5400	3270
225 SMC	4140	2740	5230	3440	6030	3900	6530	4400	3430	2030	4330	2550	5010	2870	5400	3270
250 SMA	5020	3330	6380	4150	7440	4610	8050	5210	4160	2470	5290	3060	6200	3360	6680	3840
250 SMB	5020	3330	6380	4150	7440	4610	8050	5210	4160	2470	5290	3060	6200	3360	6680	3840
280 SMA	5950	4050	7380	5010	8540	5660	8810	5890	5450	3550	6580	4210	7690	4810	7960	5040
280 SMB	5950	4050	7380	5010	-	-	-	-	5450	3550	6580	4210	-	-	-	-

# Rating plates

Single-speed motors of size 56 to 132 are stamped with 50 and 60 Hz at voltage code S and D. The current rating for each voltage range is specified on the rating plate. It represents the highest current that can exist within the voltage range at the rated output. The power factor and speed specified on the rating plate apply at 400 V 50 Hz and 460 V 60 Hz.

Single-speed motors of size 160 to 280 are stamped with 50 and 60 Hz at voltage code S and D. The rating plate is arranged in the form of a table with values for current, power factor and motor speed at six voltages.

## Motor sizes 56 to 71

<b>ABB Motors</b>			
Cl. F IP55 IEC 34			
Motor 3- M2VA 63 B-4			
3GVA062002-ASA			
017/1229A00			
COS φ 0,66/0,64			
	Hz	r/min	kW
V 380-420Y/220-240Δ	50	1380	
V 440-480Y/250-280Δ	60	1680	

## Motor sizes 80

<b>ABB Motors</b>					
Motor 3 ph Cl.F IP55 IEC 34					
M3AA 090 L-4 3GAA 092312-ASC					
IM1001					
V	Hz	r/min	kW	A	cos φ
380-420 Y / 220-240 D	50	1420	1,10	2,50 / 4,40	0,80
440-480 Y /	60	1720	1,30	2,40 /	0,80
6305-2Z/C3		6204-2Z/C3		15,00 kg	

## Motor sizes 90 to 100

<b>ABB Motors</b>					
3-Motor M2AA 090 L-4 CL.F IP 55 IEC 60034-1					
3GAA092002-ADE					
Nº.					
V	Hz	r/min	kW	A	Cos φ
660-690 Y	50	1420	1,50	2,00	0,79
380-420 D	50	1420	1,50	3,50	0,79
440-480 D	60	1710	1,75	3,50	0,79
IM1001					
6205-2Z/C3		6204-2Z/C3		16 kg	

## Motor sizes 112 to 132

<b>ABB</b>					
3-Motor M3AA 132M Cl.F IP 55 IEC 60034-1					
3G AA 132024-ADC					
No.					
V	Hz	r/min	kW	A	cos φ
660-690 Y	50	1450	7,5	8,4	0,87
380-420 Δ	50	1450	7,5	14,6	0,87
440-480 Δ	60	1750	8,8	14,3	0,87
6208-2Z/C3		6208-2Z/C3		59 kg	

## Motor sizes 160 to 280

<b>ABB</b>									
3-Motor M3AA 160 L-4									
IEC 160 M/L 42									
No.									
Ins.cl. F IP 55									
V	Hz	kW	r/min	A	cos φ	I <sub>Δ</sub> /I <sub>Y</sub>	t <sub>Δ</sub> /s		
690 Y	50	15	1460	16,7	0,82				
400 Δ	50	15	1460	29	0,82				
660 Y	50	15	1455	17,3	0,84				
380 Δ	50	15	1455	30	0,84				
415 Δ	50	15	1465	28	0,81				
440 Δ	60	18	1750	30	0,84				
Prod.code 3GAA 162 102-ADC									
6309-2Z/C3		6209-2Z/C3		103 kg					
IEC 60034-1									

# Ordering information

## Sample order

When placing an order, please state the following minimum data in the order, as in the example.

The product code of the motor is composed in accordance with the following example.

Motor type	M3AA 112 MB
Pole number	4
Mounting arrangement (IM-code)	IM B3 (IM 1001)
Rated output	5.5 kW
Product code	3GAA 112002-ACD
Variant codes if needed	

## Motor size

A	B	C	D, E, F	
M3AA	112 MB	3GAA 112 002 -	ADC, 122, 043, etc.	
		1   2   3   4   5   6   7   8   9   10   11   12   13   14...		A Motor type B Motor size C Product code D Code for mounting arrangement E Voltage and frequency code F Generation code followed by variant codes

## Explanation of the product code

### Positions 1 and 2

**3G** = Business area LV Motors

### Position 3

Enclosure and stator frame material

**A, V** = Totally enclosed motor with aluminium stator frame

### Position 4

Type of rotor

**A** = Squirrel cage rotor

### Positions 5 and 6

IEC size

<b>05</b> = 56	<b>13</b> = 132
<b>06</b> = 63	<b>16</b> = 160
<b>07</b> = 71	<b>18</b> = 180
<b>08</b> = 80	<b>20</b> = 200
<b>09</b> = 90	<b>22</b> = 225
<b>10</b> = 100	<b>25</b> = 250
<b>11</b> = 112	<b>28</b> = 280

### Position 7

Pole pairs

<b>1</b> = 2 poles
<b>2</b> = 4 poles
<b>3</b> = 6 poles
<b>4</b> = 8 poles
<b>5</b> = 10 poles
<b>6</b> = 12 poles
<b>7</b> = > 12 poles
<b>8</b> = Two-speed motors
<b>9</b> = Multi-speed motors

### Positions 8 to 10

Running number

### Position 11

- (dash)

### Position 12

Mounting arrangement

<b>A</b> = Foot-mounted motor
<b>B</b> = Flange-mounted motor. Large flange with clearance holes.
<b>C</b> = Flange-mounted motor. Small flange with tapped holes.
<b>F</b> = Foot- and flange-mounted motor. Special flange.
<b>H</b> = Foot- and flange-mounted motor. Large flange with clearance holes.
<b>J</b> = Foot- and flange-mounted motor. Small flange with tapped holes.
<b>N</b> = Flange-mounted (CI ring flange FF)
<b>P</b> = Foot-and flange-mounted motor (CI ring flange FF)
<b>V</b> = Flange-mounted motor. Special flange.

### Position 13

Voltage and frequency: See tables below

### Position 14

Version A,B,C... =

Generation code followed by variant codes

## Code letters for supplementing the product code - single speed motors

Motor size	Code letter for voltage and frequency									
	Direct start or, with $\Delta$ -connection, also Y/ $\Delta$ -start									
	S		D		H	E	F	T	U	X
	50 Hz	60 Hz	50 Hz	60 Hz	50 Hz	50 Hz	50 Hz	50 Hz	50 Hz	
56-100	220-240 V $\Delta$ 380-420 VY	440-480 VY	380-420 V $\Delta$ 660-690 VY	440-480 V $\Delta$ -	-	500 V $\Delta$ <sup>1)</sup>	500 VY	660 V $\Delta$ <sup>1)</sup>	690 V $\Delta$ <sup>1)</sup>	Other rated voltage, connection or frequency, 690 V maximum
112-132	220-240 V $\Delta$ 380-420 VY	- 440-480 VY	380-420 V $\Delta$ 660-690 VY	440-480 V $\Delta$ -	415 V $\Delta$	500 V $\Delta$	500 VY	660 V $\Delta$	690 V $\Delta$	
M2AA 160-250	230 V $\Delta$ 400 VY	- -	400 V $\Delta$ 690 VY	- -	-	500V $\Delta$	-	-	-	
M3AA 160-280	220, 230 V $\Delta$ 380,400,415 VY	- 440 VY	380,400,415V $\Delta$ 660, 690 VY	440 V $\Delta$ -	415 V $\Delta$	500 V $\Delta$	500 VY	660 V $\Delta$	690 V $\Delta$	

<sup>1)</sup> On request.

## Code letters for supplementing the product code - two-speed motors

Motor size	Code letter for voltage and frequency						
	A	S	B	D	H	E	X
56-100	-	220-230 V	-	380-400 V	400-415 V	500 V	
112-132	-	220-230 V	-	380-400 V	400-415 V	500 V	Other rated voltage or frequency, 690 V maximum
160-280	220 V	230 V	380 V	400 V	415 V	500 V	

# General purpose aluminium motors

## Technical data for totally enclosed squirrel cage three phase motors



IP 55 – IC 411 – Insulation class F, temperature rise class B

Output kW	Motor type	Product code	Speed r/min	Efficiency		Power factor cos φ	Current		Torque			
				Full load 100%	3/4 load 75%		$I_N$	$I_s$	$T_N$	$T_s$	$T_{max}$	
							A	$I_N$	Nm	$T_N$	$T_N$	$T_N$
<b>3000 r/min = 2 poles</b>			<b>400 V 50 Hz</b>				<b>Basic design</b>					
0.09	M2VA 56 A	3GVA 051 001-••	2820	59.8	53.3	0.69	0.32	3.9	0.31	2.9	2.7	
0.12	M2VA 56 B	3GVA 051 002-••	2840	67.2	63.8	0.64	0.41	4.1	0.41	3.2	2.8	
0.18	M2VA 63 A	3GVA 061 001-••	2820	73.7	70.6	0.64	0.56	4.2	0.62	3.5	3.1	
0.25	M2VA 63 B	3GVA 061 002-••	2810	77.5	75.8	0.71	0.66	4.5	0.87	3.6	3.3	
0.37 <sup>2)</sup>	M2VA 63 BB	3GVA 061 003-••	2800	73.6	73.1	0.81	0.9	3.5	1.29	2.3	2.2	
0.37	M2VA 71 A	3GVA 071 001-••	2840	77.1	76.5	0.72	1	5.5	1.25	3.8	3.9	
0.55	M2VA 71 B	3GVA 071 002-••	2830	79.2	78.2	0.76	1.35	5.7	1.86	3.6	3.7	
0.68 <sup>2)</sup>	M2VA 71 BB	3GVA 071 003-••	2800	78.9	77.4	0.82	1.59	5.2	2.33	3.2	3.3	
0.75 <sup>2)</sup>	M2VA 71 BC	3GVA 071 004-••	2800	78.5	77.9	0.85	1.7	5.1	2.57	3.1	3.2	
0.75	M2VA 80 A	3GVA 081 001-••	2870	81.2	79.3	0.75	1.8	6.2	2.49	2.9	3.6	
1.1	M2VA 80 B	3GVA 081 002-••	2850	81.4	79.5	0.78	2.5	6.1	3.69	2.3	3.5	
1.5 <sup>2)</sup>	M2VA 80 C	3GVA 081 003-••	2840	82.4	82.2	0.83	3.16	5.5	5.13	2.8	3.1	
1.5	M2AA 90 S	3GAA 091 001-••E	2870	80.1	76.2	0.82	3.35	5.5	5	2.4	3.0	
2.2	M2AA 90 L	3GAA 091 002-••E	2880	83.6	83.9	0.87	4.37	7.0	7.5	2.7	3.0	
3	M2AA 100 L	3GAA 101 001-••E	2900	86.0	84.1	0.88	5.95	7.5	10	2.7	3.6	
4	M2AA 112 M	3GAA 111 001-••A	2850	86.0	86.0	0.91	7.4	7.5	13.4	2.8	3.0	
5.5	M2AA 132 SA	3GAA 131 001-••A	2855	86.0	86.0	0.88	10.5	6.8	18.3	2.7	3.6	
7.5	M2AA 132 SB	3GAA 131 002-••A	2855	87.0	87.0	0.90	13.9	7.2	25	3.2	3.8	
11	M2AA 160 MA	3GAA 161 111-••A	2915	88.4	88.0	0.89	20.5	6.1	36	2.1	2.5	
15	M2AA 160 M	3GAA 161 112-••A	2900	89.4	89.7	0.90	27	6.0	49	2.3	2.5	
18.5	M2AA 160 L	3GAA 161 113-••A	2915	90.4	90.7	0.91	32.5	6.7	60	2.5	2.7	
22	M2AA 180 M	3GAA 181 111-••A	2925	91.5	91.7	0.89	39	8.0	72	3.0	3.2	
30	M2AA 200 LA	3GAA 201 011-••A	2945	92.0	92.1	0.88	53	7.8	97	3.1	3.4	
37	M2AA 200 L	3GAA 201 012-••A	2945	92.5	92.6	0.89	65	8.0	120	2.8	3.3	
45	M2AA 225 M	3GAA 221 011-••A	2940	93.0	93.0	0.88	80	7.7	146	2.8	3.0	
55	M2AA 250 M	3GAA 251 011-••A	2960	93.5	93.8	0.90	95	7.3	177	2.8	3.0	

<sup>1)</sup> On request.

<sup>2)</sup> High-output design.

High-output types for frame sizes 90-250 can be found on page 28.

The bullets in the product code indicate choice of mounting arrangement, voltage and frequency, generation code (see ordering information page).



# General purpose aluminium motors

## Technical data for totally enclosed squirrel cage three phase motors

IP 55 – IC 411 – Insulation class F, temperature rise class B

Output kW	Motor type	Speed r/min	380 V 50 Hz			415 V 50 Hz			Basic design			
			Efficiency %	Power factor cos φ	Current I <sub>N</sub> A	Speed r/min	Efficiency %	Power factor cos φ	Current I <sub>N</sub> A	Moment of inertia J = ¼ GD <sup>2</sup> kgm <sup>2</sup>	Weight kg	Sound pressure level L <sub>p</sub> dB(A)
<b>3000 r/min = 2 poles</b>												
0.09	M2VA 56 A	2805	58.6	0.72	0.32	2830	57.8	0.65	0.34	0.00011	3.2	48
0.12	M2VA 56 B	2825	69.2	0.68	0.4	2850	64.5	0.59	0.45	0.00012	3.4	48
0.18	M2VA 63 A	2815	74.6	0.69	0.53	2830	72.5	0.60	0.58	0.00013	3.9	54
0.25	M2VA 63 B	2800	78.5	0.75	0.64	2830	76.2	0.67	0.69	0.00016	4.4	54
0.37 <sup>2)</sup>	M2VA 63 BB	2790	71.6	0.84	0.92	2820	72.4	0.77	0.94	0.00036	4.9	54
0.37	M2VA 71 A	2830	77.3	0.75	1	2855	75.6	0.68	1.05	0.0004	5.5	58
0.55	M2VA 71 B	2820	80.2	0.81	1.31	2845	77.7	0.73	1.38	0.00045	6.5	58
0.68 <sup>2)</sup>	M2VA 71 BB	2790	77.4	0.85	1.6	2810	77.4	0.78	1.63	0.00045	6.5	58
0.75 <sup>2)</sup>	M2VA 71 BC	2790	76.0	0.87	1.75	2810	77.0	0.78	1.8	0.00045	6.5	58
0.75	M2VA 80 A	2850	82.2	0.80	1.73	2880	79.2	0.68	1.9	0.000722	9	60
1.1	M2VA 80 B	2830	81.1	0.84	2.47	2870	80.2	0.74	2.6	0.000763	11	60
1.5 <sup>2)</sup>	M2VA 80 C	2800	80.9	0.88	3.2	2820	83.2	0.81	3.1	0.001093	11.5	60
1.5	M2AA 90 S	2850	79.7	0.88	3.4	2890	79.8	0.79	3.4	0.0019	13	63
2.2	M2AA 90 L	2860	83.0	0.89	4.6	2890	83.3	0.84	4.2	0.0024	16	63
3	M2AA 100 L	2890	86.0	0.90	6.15	2910	86.0	0.85	5.95	0.0041	21	65
4	M2AA 112 M	2830	85.0	0.92	7.8	2865	86.5	0.90	7.2	0.01	25	63
5.5	M2AA 132 SA	2840	85.0	0.90	10.9	2865	86.5	0.87	10.2	0.014	37	69
7.5	M2AA 132 SB	2850	86.0	0.91	14.7	2870	87.5	0.88	13.6	0.016	42	69
11	M2AA 160 MA	<sup>1)</sup>								0.039	73	73
15	M2AA 160 M	<sup>1)</sup>								0.047	84	73
19	M2AA 160 L	<sup>1)</sup>								0.053	94	73
22	M2AA 180 M	<sup>1)</sup>								0.06	111	75
30	M2AA 200 LA	<sup>1)</sup>								0.094	139	75
37	M2AA 200 L	<sup>1)</sup>								0.115	170	75
45	M2AA 225 M	<sup>1)</sup>								0.21	209	75
55	M2AA 250 M	<sup>1)</sup>								0.31	277	74

### Recalculation factors

Recalculation factors for current at rated voltages other than 400 V 50 Hz.			
Rated voltage at 50 Hz and motor wound for	Recalculation factor	Rated voltage at 50 Hz and motor wound for	Recalculation factor
220 V	1.82	500 V	0.80
230 V	1.74	660 V	0.61
415 V	0.96	690 V	0.58

# General purpose aluminium motors

## Technical data for totally enclosed squirrel cage three phase motors



IP 55 – IC 411 – Insulation class F, temperature rise class B

Output kW	Motor type	Product code	Speed r/min	Efficiency		Power factor cos φ	Current		Torque			
				Full load 100%	3/4 load 75%		$I_N$	$I_s$	$T_N$	$T_s$	$T_{max}$	
<b>1500 r/min = 4 poles</b>			<b>400 V 50 Hz</b>				<b>Basic design</b>					
0.06	M2VA 56 A	3GVA 052 001-••	1340	51.1	45.8	0.67	0.26	2.5	0.43	2.2	2.2	
0.09	M2VA 56 B	3GVA 052 002-••	1370	55.5	50.2	0.62	0.38	2.8	0.63	2.9	2.9	
0.12	M2VA 63 A	3GVA 062 001-••	1400	63.7	58.4	0.59	0.46	3.1	0.82	2.6	2.6	
0.18	M2VA 63 B	3GVA 062 002-••	1380	65.6	62.1	0.64	0.63	3.1	1.25	2.5	2.6	
0.25 <sup>2)</sup>	M2VA 63 BB	3GVA 062 003-••	1370	70.3	67.4	0.67	0.78	3.2	1.75	2.5	2.1	
0.25	M2VA 71 A	3GVA 072 001-••	1410	70.4	69.1	0.71	0.74	4.3	1.71	2.7	2.9	
0.37	M2VA 71 B	3GVA 072 002-••	1420	74.6	72.1	0.69	1.05	4.4	2.51	2.6	2.8	
0.45 <sup>2)</sup>	M2VA 71 BB	3GVA 072 003-••	1390	75.5	75.3	0.76	1.15	4.1	3.11	2.1	2.3	
0.55 <sup>2)</sup>	M2VA 71 C	3GVA 072 004-••	1410	77.3	76.9	0.73	1.45	4.8	3.74	2.7	2.9	
0.55	M2VA 80 A	3GVA 082 001-••	1390	75.3	73.1	0.76	1.4	4.6	3.75	2.6	2.9	
0.75	M2VA 80 B	3GVA 082 002-••	1410	78.2	75.6	0.74	1.9	4.7	5.08	3.5	3.9	
0.95 <sup>2)</sup>	M2VA 80 C	3GVA 082 003-••	1410	78.9	77.9	0.75	2.35	4.3	6.44	2.9	3.3	
1.1	M2AA 90 S	3GAA 092 001-••E	1410	77.5	76.4	0.81	2.59	5.0	7.5	2.2	2.7	
1.5	M2AA 90 L	3GAA 092 002-••E	1420	80.3	78.1	0.79	3.45	5.0	10	2.4	2.9	
2.2	M2AA 100 LA	3GAA 102 001-••E	1430	83.0	82.7	0.81	4.8	5.5	15	2.4	2.9	
3	M2AA 100 LB	3GAA 102 002-••A	1430	85.0	83.9	0.81	6.48	5.5	20	2.5	2.9	
4	M2AA 112 M	3GAA 112 001-••A	1435	84.5	85.5	0.80	8.6	7.0	27	2.8	3.0	
5.5	M2AA 132 S	3GAA 132 001-••A	1450	87.0	87.0	0.83	11.1	7.3	36	2.2	3.0	
7.5	M2AA 132 M	3GAA 132 002-••A	1450	88.0	88.0	0.83	14.8	7.9	49	2.5	3.2	
11	M2AA 160 M	3GAA 162 111-••A	1460	88.4	88.8	0.81	22	6.5	72	2.4	2.6	
15	M2AA 160 L	3GAA 162 112-••A	1460	90.0	90.5	0.82	29	7.2	98	2.8	2.8	
18.5	M2AA 180 M	3GAA 182 111-••A	1460	90.8	91.3	0.81	36.5	7.5	121	3.1	3.5	
22	M2AA 180 L	3GAA 182 112-••A	1460	91.1	91.5	0.82	42	8.0	144	3.0	3.1	
30	M2AA 200 L	3GAA 202 011-••A	1470	92.0	92.1	0.80	59	7.8	195	3.0	3.4	
37	M2AA 225 S	3GAA 222 011-••A	1475	92.8	93.0	0.85	68	8.0	240	3.2	3.0	
45	M2AA 225 M	3GAA 222 012-••A	1475	93.0	93.1	0.84	84	8.5	291	3.5	3.2	
55	M2AA 250 M	3GAA 252 011-••A	1475	93.7	94.0	0.84	98	7.3	355	2.7	2.8	

<sup>1)</sup> On request.

<sup>2)</sup> High-output design.

High-output types for frame sizes 90-250 can be found on page 30.

The bullets in the product code indicate choice of mounting arrangement, voltage and frequency, generation code (see ordering information page).

# General purpose aluminium motors

## Technical data for totally enclosed squirrel cage three phase motors

IP 55 – IC 411 – Insulation class F, temperature rise class B

Output kW	Motor type	Speed r/min	380 V 50 Hz			415 V 50 Hz			Basic design				
			Efficiency %	Power factor cos φ	Current I <sub>N</sub> A	Speed r/min	Efficiency %	Power factor cos φ	Current I <sub>N</sub> A	Moment of inertia J = ¼ GD <sup>2</sup> kgm <sup>2</sup>	Weight kg	Sound pressure level L <sub>p</sub> dB(A)	
<b>1500 r/min = 4 poles</b>													
0.06	M2VA 56 A	1335	50.5	0.70	0.26	1360	49.9	0.63	0.28	0.00017	3.2	36	
0.09	M2VA 56 B	1360	57.1	0.66	0.37	1390	54.9	0.58	0.4	0.00018	3.4	36	
0.12	M2VA 63 A	1390	63.1	0.63	0.44	1400	62.5	0.55	0.49	0.00019	4	40	
0.18	M2VA 63 B	1370	66.9	0.67	0.63	1400	64.3	0.59	0.67	0.00026	4.5	40	
0.25 <sup>2)</sup>	M2VA 63 BB	1360	70.9	0.71	0.76	1380	69.1	0.63	0.8	0.0003	5	40	
0.25	M2VA 71 A	1400	69.9	0.74	0.75	1420	69.2	0.67	0.77	0.00066	5.5	45	
0.37	M2VA 71 B	1410	73.6	0.76	1.02	1430	73.4	0.65	1.1	0.00089	6.5	45	
0.45 <sup>2)</sup>	M2VA 71 BB	1380	75.1	0.80	1.12	1400	74.0	0.72	1.2	0.00089	6.5	45	
0.55 <sup>2)</sup>	M2VA 71 C	1400	77.0	0.77	1.4	1420	76.1	0.69	1.5	0.0011	7	45	
0.55	M2VA 80 A	1380	75.5	0.82	1.35	1400	73.8	0.68	1.55	0.001257	9	50	
0.75	M2VA 80 B	1400	78.7	0.81	1.8	1410	76.0	0.67	2.05	0.001565	10.5	50	
0.95 <sup>2)</sup>	M2VA 80 C	1400	79.1	0.81	2.3	1430	76.4	0.66	2.65	0.001948	11	50	
1.1	M2AA 90 S	1410	76.3	0.83	2.66	1430	77.7	0.76	2.6	0.0032	13	50	
1.5	M2AA 90 L	1420	79.9	0.82	3.5	1430	80.3	0.77	3.45	0.0043	16	50	
2.2	M2AA 100 LA	1430	83.0	0.83	4.83	1430	83.0	0.78	4.85	0.0069	21	64	
3	M2AA 100 LB	1430	85.0	0.85	6.58	1430	85.0	0.77	6.55	0.0082	24	66	
4	M2AA 112 M	1425	84.0	0.80	8.9	1440	85.0	0.75	8.8	0.015	27	56	
5.5	M2AA 132 S	1445	86.0	0.85	11.5	1455	87.5	0.81	10.9	0.031	40	59	
7.5	M2AA 132 M	1445	87.0	0.85	15.3	1455	88.0	0.81	14.5	0.038	48	59	
11	M2AA 160 M	<sup>1)</sup>								0.067	75	62	
15	M2AA 160 L	<sup>1)</sup>								0.088	92	62	
19	M2AA 180 M	<sup>1)</sup>								0.102	110	64	
22	M2AA 180 L	<sup>1)</sup>								0.127	128	64	
30	M2AA 200 L	<sup>1)</sup>								0.225	177	67	
37	M2AA 225 S	<sup>1)</sup>								0.35	216	68	
45	M2AA 225 M	<sup>1)</sup>								0.41	237	68	
55	M2AA 250 M	<sup>1)</sup>								0.5	286	66	

### Recalculation factors

Recalculation factors for current at rated voltages other than 400 V 50 Hz.			
Rated voltage at 50 Hz and motor wound for	Recalculation factor	Rated voltage at 50 Hz and motor wound for	Recalculation factor
220 V	1.82	500 V	0.80
230 V	1.74	660 V	0.61
415 V	0.96	690 V	0.58

# General purpose aluminium motors

## Technical data for totally enclosed squirrel cage three phase motors



IP 55 – IC 411 – Insulation class F, temperature rise class B

Output kW	Motor type	Product code	Speed r/min	Efficiency		Power factor cos φ	Current		Torque			
				Full load 100%	3/4 load 75%		$I_N$	$I_s$	$T_N$	$T_s$	$T_{max}$	
							A	$I_N$	Nm	$T_N$	$T_N$	$T_N$
<b>3000 r/min = 2 poles</b>			<b>400 V 50 Hz</b>				<b>Basic design</b>					
1.1	M3VA 80 C	3GVA 081 313-••	2850	81.4	81.2	0.85	2.3	8.1	3.69	4.2	3.5	
1.5	M3AA 90 L	3GAA 091 312-••E	2900	85.9	86.5	0.87	3	7.7	5	2.7	3.6	
2.2	M3AA 90 LB	3GAA 091 313-••E	2880	85.8	87.1	0.87	4.4	7.4	7.3	3.0	3.6	
3	M3AA 100 LB	3GAA 101 312-••E	2920	87.6	87.5	0.86	5.9	10.0	9.9	3.9	4.9	
4	M3AA 112 M	3GAA 111 022-••C	2860	87.7	89.4	0.93	7.1	7.9	13.4	2.7	3.1	
5.5	M3AA 132 SA	3GAA 131 023-••C	2900	88.6	88.9	0.88	10.1	9.0	18.1	3.8	4.6	
7.5	M3AA 132 SB	3GAA 131 024-••C	2915	90.9	91.3	0.90	13.3	11.0	24.6	5.1	5.2	
11	M3AA 160 MA	3GAA 161 101-••C	2930	91.2	91.2	0.88	20	6.3	36	1.9	2.5	
15	M3AA 160 M	3GAA 161 102-••C	2920	91.7	91.7	0.90	26.5	6.6	49	2.3	2.5	
18.5	M3AA 160 L	3GAA 161 103-••C	2920	92.4	92.4	0.91	32	7.3	60	2.6	2.7	
22	M3AA 180 M	3GAA 181 101-••C	2930	92.8	92.8	0.89	38.5	7.2	71	2.5	2.7	
30	M3AA 200 MLA	3GAA 201 001-••C	2955	93.2	93.2	0.88	53	7.3	97	2.4	3.1	
37	M3AA 200 MLB	3GAA 201 002-••C	2950	93.6	93.6	0.89	64	7.3	120	2.5	3.2	
45	M3AA 225 SMB	3GAA 221 001-••C	2960	93.9	93.9	0.88	79	7.3	145	2.5	2.8	
55	M3AA 250 SMA	3GAA 251 001-••C	2970	94.4	94.1	0.89	95	7.4	177	1.7	2.7	
75 <sup>1)</sup>	M3AA 280 SMA	3GAA 281 001-••C	2970	94.7	94.7	0.90	127	8.2	241	2.6	3.2	
90 <sup>1)</sup>	M3AA 280 SMB	3GAA 281 002-••C	2970	95.4	95.6	0.90	152	8.3	290	2.7	3.4	
<b>3000 r/min = 2 poles</b>			<b>400 V 50 Hz</b>				<b>High-output design</b>					
2.7 <sup>1)</sup>	M3AA 90 LB	3GAA 091 003-••E	2860	80.7	83.5	0.86	5.7	7.0	9	2.6	3.0	
4 <sup>1)</sup>	M3AA 100 LB	3GAA 101 002-••E	2900	85.0	84.3	0.86	8.1	7.5	13	2.7	3.6	
5.5 <sup>1)</sup>	M3AA 112 MB	3GAA 111 002-••C	2855	86.5	86.5	0.93	9.9	7.3	18.4	2.6	3.5	
9.2 <sup>1)</sup>	M3AA 132 SBB	3GAA 131 004-••C	2840	86.8	88.3	0.92	16.8	8.5	31	3.3	3.6	
11 <sup>1)</sup>	M3AA 132 SC	3GAA 131 003-••C	2835	87.0	87.0	0.93	19.6	8.0	37	3.2	3.3	
22 <sup>1)</sup>	M3AA 160 LB	3GAA 161 104-••C	2920	92.1	92.1	0.91	38	7.1	72	2.6	2.6	
30	M3AA 180 LB	3GAA 181 102-••C	2945	93.7	93.7	0.89	53	8.3	97	3.1	3.4	
45	M3AA 200 MLC	3GAA 201 003-••C	2950	93.8	93.8	0.89	78	7.3	146	2.6	3.3	
55	M3AA 225 SMC	3GAA 221 002-••C	2960	94.3	94.3	0.89	95	7.0	177	2.5	2.9	
55 <sup>1)</sup>	M3AA 200 MLD	3GAA 201 004-••C	2940	94.0	94.2	0.89	95	7.8	179	3.1	3.1	
75 <sup>1)</sup>	M3AA 250 SMB	3GAA 251 002-••C	2970	94.7	94.7	0.90	127	8.2	241	2.6	3.2	
80 <sup>1)</sup>	M3AA 225 SMD	3GAA 221 003-••C	2960	94.7	94.7	0.86	143	7.5	258	2.9	3.1	
95 <sup>1)</sup>	M3AA 250 SMC	3GAA 251 003-••C	2965	95.4	95.6	0.90	160	8.0	306	2.6	3.2	

<sup>1)</sup> Temperature rise class F.

<sup>2)</sup> On request.

The bullets in the product code indicate choice of mounting arrangement, voltage and frequency, generation code (see ordering information page).

# General purpose aluminium motors

## Technical data for totally enclosed squirrel cage three phase motors

IP 55 – IC 411 – Insulation class F, temperature rise class B

Output kW	Motor type	Speed r/min	Efficiency %	Power factor cos φ	Current I <sub>N</sub> A	Speed r/min	Efficiency %	Power factor cos φ	Current I <sub>N</sub> A	Moment of inertia J = ¼ GD <sup>2</sup> kgm <sup>2</sup>	Weight kg	Sound pressure level L <sub>p</sub> dB(A)
<b>3000 r/min = 2 poles</b>		<b>380 V 50 Hz</b>				<b>415 V 50 Hz</b>				<b>Basic design</b>		
1.1	M3VA 80 C	2830	81.1	0.88	3.1	2870	81.2	0.8	2.35	0.001093	11	60
1.5	M3AA 90 L	2880	85.1	0.87	3.1	2910	85.9	0.84	2.9	0.0024	16	63
2.2	M3AA 90 LB	2860	85.1	0.88	4.5	2890	86.1	0.84	4.3	0.0027	18	63
3	M3AA 100 LB	2910	87.5	0.87	6.1	2930	87.7	0.83	5.8	0.005	25	62
4	M3AA 112 M	2860	86.7	0.93	7.6	2860	88.0	0.93	6.9	0.012	33	63
5.5	M3AA 132 SA	2900	88.6	0.89	10.7	2900	88.8	0.86	9.9	0.016	42	69
7.5	M3AA 132 SB	2915	90.5	0.90	13.8	2915	91.2	0.90	12.9	0.022	56	69
11	M3AA 160 MA	2915	90.8	0.89	20.5	2935	91.3	0.86	19.4	0.039	105	69
15	M3AA 160 M	2905	91.2	0.90	27.5	2925	92.0	0.89	25.5	0.047	84	69
18.5	M3AA 160 L	2910	92.0	0.91	33.5	2930	92.6	0.90	31	0.053	94	69
22	M3AA 180 M	2930	92.4	0.90	40.5	2945	93.0	0.88	37.5	0.077	119	69
30	M3AA 200 MLA	2955	93.1	0.89	55	2960	93.3	0.86	52	0.15	175	72
37	M3AA 200 MLB	2950	93.4	0.89	68	2955	93.7	0.87	63	0.18	200	72
45	M3AA 225 SMB	2955	93.7	0.89	82	2965	93.9	0.87	77	0.26	235	74
55	M3AA 250 SMA	2960	94.3	0.89	100	2970	94.4	0.88	92	0.49	285	75
75 <sup>1)</sup>	M3AA 280 SMA	2965	94.6	0.90	133	2970	94.7	0.89	123	0.57	375	75
90 <sup>1)</sup>	M3AA 280 SMB	2965	95.3	0.90	158	2970	95.4	0.89	148	0.59	390	75
<b>3000 r/min = 2 poles</b>		<b>380 V 50 Hz</b>				<b>415 V 50 Hz</b>				<b>High-output design</b>		
2.7 <sup>1)</sup>	M3AA 90 LB	2840	80.2	0.89	5.8	2870	80.6	0.83	5.7	0.0027	18	63
4 <sup>1)</sup>	M3AA 100 LB	2890	85.0	0.88	8.3	2910	85.0	0.84	7.8	0.005	25	68
5.5 <sup>1)</sup>	M3AA 112 MB	2835	85.5	0.93	10.5	2865	87.5	0.92	9.5	0.012	33	63
9.2 <sup>1)</sup>	M3AA 132 SBB	2830	85.8	0.92	17.6	2850	87.4	0.93	16.2	0.02	50	69
11 <sup>1)</sup>	M3AA 132 SC	2815	86.5	0.93	21	2845	88.0	0.93	18.9	0.022	56	69
22 <sup>1)</sup>	M3AA 160 LB	2910	91.6	0.91	40	2925	92.4	0.90	37	0.058	100	69
30	M3AA 180 LB	2940	93.5	0.90	55	2950	93.8	0.87	52	0.092	137	70
45	M3AA 200 MLC	2945	93.5	0.89	82	2955	93.8	0.88	76	0.19	205	72
55	M3AA 225 SMC	2950	94.2	0.89	100	2965	94.3	0.88	92	0.29	260	74
55 <sup>1)</sup>	M3AA 200 MLD <sup>2)</sup>									0.2	215	
75 <sup>1)</sup>	M3AA 250 SMB	2965	94.6	0.90	133	2970	94.7	0.89	123	0.57	375	75
80 <sup>1)</sup>	M3AA 225 SMD <sup>2)</sup>									0.3	275	74
95 <sup>1)</sup>	M3AA 250 SMC <sup>2)</sup>									0.59	345	75

### Recalculation factors

Recalculation factors for current at rated voltages other than 400 V 50 Hz.

Rated voltage at 50 Hz and motor wound for	Recalculation factor	Rated voltage at 50 Hz and motor wound for	Recalculation factor
220 V	1.82	500 V	0.80
230 V	1.74	660 V	0.61
415 V	0.96	690 V	0.58

# General purpose aluminium motors

## Technical data for totally enclosed squirrel cage three phase motors



IP 55 – IC 411 – Insulation class F, temperature rise class B

Output kW	Motor type	Product code	Speed r/min	Efficiency		Power factor cos φ	Current		Torque			
				Full load 100%	3/4 load 75%		$I_N$	$I_s$	$T_N$	$T_s$	$T_{max}$	
							A	$I_N$	Nm	$T_N$	$T_N$	
<b>1500 r/min = 4 poles</b>			<b>400 V 50 Hz</b>				<b>Basic design</b>					
1.1	M3AA 90 L	3GAA 092 312-••E	1420	83.9	84.3	0.80	2.4	6.1	7.4	2.9	3.4	
1.5	M3AA 100 LA	3GAA 102 311-••E	1440	85.6	85.5	0.82	3.2	6.9	10	2.8	3.4	
2.2	M3AA 100 LC	3GAA 102 313-••E	1450	86.8	86.5	0.77	4.8	8.5	14.5	4.0	4.6	
3	M3AA 112 MA	3GAA 112 021-••C	1455	87.5	87.8	0.81	6.2	7.9	19.7	2.7	3.7	
4	M3AA 112 M	3GAA 112 022-••C	1455	89.3	89.6	0.76	8.6	8.5	26.3	3.0	4.1	
5.5	M3AA 132 S	3GAA 132 023-••C	1460	89.3	90.5	0.84	10.6	7.6	36	2.2	3.4	
7.5	M3AA 132 M	3GAA 132 024-••C	1450	90.1	91.4	0.87	14	8.5	49	3.3	3.2	
11	M3AA 160 M	3GAA 162 101-••C	1465	91.5	92.0	0.83	21	7.9	72	3.4	3.4	
15	M3AA 160 L	3GAA 162 102-••C	1455	91.8	92.0	0.84	28.5	9.6	98	2.9	3.2	
18.5	M3AA 180 M	3GAA 182 101-••C	1470	92.3	92.3	0.84	35	7.0	120	3.1	2.7	
22	M3AA 180 L	3GAA 182 102-••C	1470	93.1	93.6	0.85	40	8.5	143	3.6	2.9	
30	M3AA 200 MLB	3GAA 202 001-••C	1475	93.4	93.6	0.84	55	7.0	194	2.5	2.8	
37	M3AA 225 SMA	3GAA 222 001-••C	1480	93.6	93.6	0.84	68	6.6	239	2.4	2.5	
45	M3AA 225 SMB	3GAA 222 002-••C	1480	94.2	94.2	0.83	83	6.7	290	2.7	2.6	
55	M3AA 250 SMA	3GAA 252 001-••C	1480	94.6	94.6	0.86	98	7.5	355	2.3	2.8	
75	M3AA 280 SMA	3GAA 282 001-••C	1480	94.8	95.0	0.86	132	7.1	486	3.4	3.5	
90	M3AA 280 SMB	3GAA 282 002-••C	1475	95.0	95.5	0.88	157	7.7	583	5.0	3.2	
<b>1500 r/min = 4 poles</b>			<b>400 V 50 Hz</b>				<b>High-output design</b>					
1.85	<sup>1)</sup> M3AA 90 L	3GAA 092 003-••E	1390	79.5	78.1	0.80	4.4	4.5	13	2.2	2.4	
2.2	<sup>1)</sup> M3AA 90 LB	3GAA 092 004-••E	1390	80.3	81.0	0.83	4.85	4.5	15	2.2	2.4	
4	<sup>1)</sup> M3AA 100 LC	3GAA 102 003-••E	1420	81.0	81.7	0.82	8.65	5.5	27	2.5	2.8	
5.5	<sup>1)</sup> M3AA 112 MB	3GAA 112 002-••C	1425	84.5	85.5	0.83	11.4	7.1	37	2.8	3.1	
9.2	<sup>1)</sup> M3AA 132 MBA	3GAA 132 004-••C	1445	87.8	89.2	0.87	17.5	7.2	61	2.7	2.7	
11	<sup>1)</sup> M3AA 132 MB	3GAA 132 003-••C	1450	88.8	89.9	0.86	21	7.7	72	2.5	2.5	
18.5	<sup>1)</sup> M3AA 160 LB	3GAA 162 103-••C	1450	90.5	90.5	0.84	36	6.9	122	2.9	2.9	
30	<sup>1)</sup> M3AA 180 LB	3GAA 182 103-••C	1465	92.5	92.5	0.84	56	6.9	195	3.2	2.8	
37	<sup>1)</sup> M3AA 200 MLB	3GAA 202 002-••C	1475	93.4	93.4	0.84	68	7.8	236	3.6	3.2	
48	<sup>1)</sup> M3AA 200 MLC	3GAA 202 003-••C	1470	93.6	94.1	0.84	89	8.1	311	4.4	3.2	
55	<sup>1)</sup> M3AA 225 SMC	3GAA 222 003-••C	1480	94.6	94.6	0.84	100	7.3	355	3.1	2.8	
73	<sup>1)</sup> M3AA 225 SMD	3GAA 222 004-••C	1475	94.2	94.5	0.85	132	8.1	473	4.5	3.2	
75	M3AA 250 SMB	3GAA 252 002-••C	1480	94.8	95.0	0.86	132	7.1	486	3.4	3.5	
95	<sup>1)</sup> M3AA 250 SMC	3GAA 252 003-••C	1475	94.8	95.1	0.88	165	7.3	616	4.7	3.1	

<sup>1)</sup> Temperature rise class F.

<sup>2)</sup> On request.

The bullets in the product code indicate choice of mounting arrangement, voltage and frequency, generation code (see ordering information page).

# General purpose aluminium motors

## Technical data for totally enclosed squirrel cage three phase motors

IP 55 – IC 411 – Insulation class F, temperature rise class B

Output kW	Motor type	Speed r/min	Efficiency %	Power factor cos φ	Current I <sub>N</sub> A	Speed r/min	Efficiency %	Power factor cos φ	Current I <sub>N</sub> A	Moment of inertia J = ¼ GD <sup>2</sup> kgm <sup>2</sup>	Weight level kg	Sound pressure level L <sub>p</sub> dB(A)
<b>1500 r/min = 4 poles</b>		<b>380 V 50 Hz</b>				<b>415 V 50 Hz</b>				<b>Basic design</b>		
1.1	M3AA 90 L	1410	83.6	0.82	2.5	1430	84.4	0.78	2.4	0.0043	16	50
1.5	M3AA 100 LA	1430	85.4	0.84	3.2	1450	86.1	0.79	3.1	0.0069	21	54
2.2	M3AA 100 LC	1440	86.8	0.80	4.8	1460	86.9	0.74	4.8	0.009	25	54
3	M3AA 112 MA	1455	87.4	0.81	6.5	1455	87.8	0.80	6.1	0.018	34	56
4	M3AA 112 M	1455	88.0	0.77	9	1455	89.0	0.77	8.2	0.018	34	56
5.5	M3AA 132 S	1460	89.2	0.84	11	1460	89.4	0.84	10.3	0.038	48	59
7.5	M3AA 132 M	1450	90.1	0.87	14.7	1450	90.2	0.87	13.5	0.048	59	59
11	M3AA 160 M	1460	91.1	0.84	22	1470	91.6	0.82	20.5	0.091	94	62
15	M3AA 160 L	1450	91.8	0.84	30	1460	91.9	0.82	28	0.102	103	62
18.5	M3AA 180 M	1465	91.7	0.85	36	1470	92.2	0.83	34	0.161	124	62
22	M3AA 180 L	1465	92.7	0.86	42	1475	93.3	0.84	38	0.225	161	63
30	M3AA 200 MLB	1470	93.1	0.85	58	1475	93.5	0.84	54	0.34	205	63
37	M3AA 225 SMA	1475	93.4	0.84	72	1480	93.7	0.81	68	0.37	215	66
45	M3AA 225 SMB	1475	94.0	0.85	86	1480	94.2	0.81	82	0.42	230	66
55	M3AA 250 SMA	1475	94.3	0.86	103	1480	94.7	0.84	96	0.72	275	67
75	M3AA 280 SMA	1475	94.3	0.87	139	1480	94.8	0.86	128	0.88	380	67
90	M3AA 280 SMB	1470	95.0	0.89	164	1475	95.1	0.87	153	0.95	405	67
<b>1500 r/min = 4 poles</b>		<b>380 V 50 Hz</b>				<b>415 V 50 Hz</b>				<b>High-output design</b>		
1.85 <sup>1)</sup>	M3AA 90 L	1380	78.8	0.83	4.4	1400	79.5	0.76	4.35	0.0043	16	50
2.2 <sup>1)</sup>	M3AA 90 LB	1380	78.4	0.85	5.1	1400	80.8	0.80	4.9	0.0048	17	50
4 <sup>1)</sup>	M3AA 100 LC	1410	80.0	0.82	8.8	1420	82.0	0.75	8.7	0.009	25	60
5.5 <sup>1)</sup>	M3AA 112 MB	1415	84.5	0.85	11.7	1430	85.5	0.79	11.4	0.018	34	56
9.2 <sup>1)</sup>	M3AA 132 MBA	1445	88.0	0.87	18.4	1445	88.3	0.87	16.8	0.048	59	59
11 <sup>1)</sup>	M3AA 132 MB	1445	88.2	0.87	22	1455	88.9	0.83	21	0.048	59	59
18.5 <sup>1)</sup>	M3AA 160 LB	1440	89.8	0.85	37	1450	90.8	0.83	34	0.102	103	63
30 <sup>1)</sup>	M3AA 180 LB	1465	92.2	0.85	58	1470	92.7	0.82	55	0.225	161	63
37 <sup>1)</sup>	M3AA 200 MLB	1475	93.3	0.85	71	1475	93.3	0.82	67	0.34	205	63
48 <sup>1)</sup>	M3AA 200 MLC <sup>2)</sup>									0.38	270	63
55 <sup>1)</sup>	M3AA 225 SMC	1475	94.5	0.84	105	1480	94.6	0.82	99	0.49	265	66
73 <sup>1)</sup>	M3AA 225 SMD <sup>2)</sup>									0.56	290	66
75 <sup>1)</sup>	M3AA 250 SMB	1475	94.3	0.87	139	1480	94.8	0.86	128	0.88	335	67
95 <sup>1)</sup>	M3AA 250 SMC <sup>2)</sup>									0.95	360	67

### Recalculation factors

Recalculation factors for current at rated voltages other than 400 V 50 Hz.			
Rated voltage at 50 Hz and motor wound for	Recalculation factor	Rated voltage at 50 Hz and motor wound for	Recalculation factor
220 V	1.82	500 V	0.80
230 V	1.74	660 V	0.61
415 V	0.96	690 V	0.58

# General purpose aluminium motors

## Technical data for totally enclosed squirrel cage three phase motors

IP 55 – IC 411 – Insulation class F, temperature rise class B

Output kW	Motor type	Product code	Speed r/min	Efficiency		Power factor cos φ	Current		Torque			
				Full load 100%	3/4 load 75%		$I_N$	$I_s$	$T_N$	$T_s$	$T_{max}$	
							A		Nm			
<b>1000 r/min = 6 poles</b>			<b>400 V 50 Hz</b>				<b>Basic design</b>					
0.09	M2VA 63 A	3GVA 063 001-••	910	47.1	42.5	0.56	0.51	2.1	0.95	2.1	2.1	
0.12	M2VA 63 B	3GVA 063 002-••	910	57.5	54.0	0.58	0.54	2.1	1.27	2.1	2.1	
0.18	M2VA 71 A	3GVA 073 001-••	920	61.1	57.7	0.69	0.64	2.9	1.88	2.1	2.2	
0.25	M2VA 71 B	3GVA 073 002-••	920	64.9	62.3	0.65	0.86	3.2	2.61	2.5	2.7	
0.37	M2VA 80 A	3GVA 083 001-••	925	72.9	70.8	0.72	1.04	3.8	3.82	3.1	3.4	
0.55	M2VA 80 B	3GVA 083 002-••	925	73.3	71.9	0.71	1.55	3.4	5.68	2.9	3.1	
0.75	M3AA 90 S	3GAA 093 001-••E	930	71.5	70.7	0.67	2.36	4.0	7.5	1.9	2.3	
1.1	M3AA 90 L	3GAA 093 002-••E	930	74.4	72.5	0.69	3.25	4.0	11	2.1	2.4	
1.5	M3AA 100 L	3GAA 103 001-••E	950	80.0	77.0	0.71	3.92	4.5	15	1.9	2.3	
2.2	M3AA 112 M	3GAA 113 001-••C	940	80.5	81.0	0.74	5.4	5.6	22	2.1	2.7	
3	M3AA 132 S	3GAA 133 001-••C	960	84.5	84.8	0.75	6.9	6.5	30	2.1	3.0	
4	M3AA 132 MA	3GAA 133 002-••C	960	85.5	86.1	0.78	8.7	7.1	40	2.6	2.8	
5.5	M3AA 132 MB	3GAA 133 003-••C	955	86.0	87.0	0.78	11.9	7.0	55	3.0	2.8	
7.5	M3AA 160 M	3GAA 163 101-••C	970	89.3	89.3	0.79	15.4	6.7	74	2.0	2.8	
11	M3AA 160 L	3GAA 163 102-••C	970	89.8	89.8	0.78	23	7.1	109	2.2	2.9	
15	M3AA 180 L	3GAA 183 101-••C	970	90.8	90.8	0.78	31	7.0	148	2.1	3.0	
18.5	M3AA 200 MLA	3GAA 203 001-••C	985	91.1	91.1	0.81	36	7.0	179	2.5	2.7	
22	M3AA 200 MLB	3GAA 203 002-••C	980	91.7	91.7	0.81	43	7.2	214	2.5	2.7	
30	M3AA 225 SMB	3GAA 223 001-••C	985	92.8	92.8	0.83	56	6.6	291	2.5	2.7	
37	M3AA 250 SMA	3GAA 253 001-••C	985	93.7	93.7	0.83	69	7.3	359	2.8	2.8	
45	M3AA 280 SMA	3GAA 283 001-••C	985	94.1	94.1	0.84	82	7.3	436	2.8	2.8	
<b>1000 r/min = 6 poles</b>			<b>400 V 50 Hz</b>				<b>High-output design</b>					
0.15	M2VA 63 BB	3GVA 063 003-••	900	56.9	52.1	0.54	0.74	2.2	1.61	2.2	2.3	
0.32	M2VA 71 C	3GVA 073 003-••	920	64.8	61.6	0.63	1.15	3.2	3.33	2.6	2.8	
1.3 <sup>1)</sup>	M3AA 90 LB	3GAA 093 003-••E	910	69.0	69.0	0.71	3.85	4.0	13.5	1.9	2.2	
2.2 <sup>1)</sup>	M3AA 100 LC	3GAA 103 002-••E	940	77.0	72.8	0.71	5.9	4.5	22	1.9	2.3	
3 <sup>1)</sup>	M3AA 112 MB	3GAA 113 002-••C	935	80.0	81.2	0.76	7.2	5.5	31	2.5	2.7	
6.3 <sup>1)</sup>	M3AA 132 MC	3GAA 133 004-••C	960	84.9	85.0	0.75	14.5	7.3	63	2.3	3.1	
14 <sup>1)</sup>	M3AA 160 LB	3GAA 163 103-••C	960	89.1	89.1	0.77	29.5	7.6	139	2.7	3.1	
18.5 <sup>1)</sup>	M3AA 180 LB	3GAA 183 102-••C	965	90.6	90.6	0.79	37.5	6.2	183	2.0	2.6	
30 <sup>1)</sup>	M3AA 200 MLC	3GAA 203 003-••C	980	91.7	91.7	0.81	56	7.5	292	3.3	3.0	
37	M3AA 225 SMC	3GAA 223 002-••C	985	93.2	93.2	0.83	69	7.7	359	3.1	3.0	
45	M3AA 250 SMB	3GAA 253 002-••C	985	94.1	94.1	0.84	82	7.3	436	2.8	2.8	

<sup>1)</sup> Temperature rise class F.

The bullets in the product code indicate choice of mounting arrangement, voltage and frequency, generation code (see ordering information page).



# General purpose aluminium motors

## Technical data for totally enclosed squirrel cage three phase motors

IP 55 – IC 411 – Insulation class F, temperature rise class B

Output kW	Motor type	Speed r/min	Efficiency %	Power factor cos φ	Current I <sub>N</sub> A	Speed r/min	Efficiency %	Power factor cos φ	Current I <sub>N</sub> A	Moment of inertia J = ¼ GD <sup>2</sup> kgm <sup>2</sup>	Weight level kg	Sound pressure level L <sub>p</sub> dB(A)
<b>1000 r/min = 6 poles</b>		<b>380 V 50 Hz</b>				<b>415 V 50 Hz</b>				<b>Basic design</b>		
0.09	M2VA 63 A	905	49.6	0.59	0.46	925	44.9	0.52	0.55	0.0002	4	38
0.12	M2VA 63 B	905	59.1	0.61	0.52	925	54.8	0.54	0.57	0.00027	4.5	38
0.18	M2VA 71 A	910	60.3	0.73	0.62	930	59.8	0.62	0.7	0.00063	5.5	42
0.25	M2VA 71 B	910	65.4	0.68	0.85	930	63.6	0.61	0.9	0.00081	6.5	42
0.37	M2VA 80 A	905	72.7	0.77	1.03	920	71.4	0.66	1.1	0.001842	9	47
0.55	M2VA 80 B	905	73.1	0.77	1.5	915	71.2	0.65	1.65	0.002176	10	47
0.75	M3AA 90 S	920	70.6	0.72	2.3	930	70.6	0.64	2.36	0.0032	13	44
1.1	M3AA 90 L	920	73.9	0.73	3.2	930	74.2	0.66	3.25	0.0043	16	44
1.5	M3AA 100 L	940	79.0	0.74	3.96	960	80.0	0.67	3.95	0.0082	23	49
2.2	M3AA 112 M	930	80.0	0.78	5.4	950	80.5	0.71	5.4	0.015	27	54
3	M3AA 132 S	955	84.0	0.77	7.1	965	84.0	0.72	6.9	0.031	39	61
4	M3AA 132 MA	955	85.0	0.81	8.9	965	85.5	0.75	8.7	0.038	46	61
5.5	M3AA 132 MB	950	85.5	0.81	12.2	960	86.0	0.76	11.8	0.045	54	61
7.5	M3AA 160 M	960	88.7	0.80	16.1	970	89.6	0.77	15.1	0.089	88	59
11	M3AA 160 L	960	89.4	0.80	23.5	970	90.0	0.76	22.4	0.107	102	59
15	M3AA 180 L	970	90.9	0.79	32	975	91.1	0.74	31	0.217	151	59
18.5	M3AA 200 MLA	980	90.8	0.81	38	985	91.1	0.78	36	0.37	165	63
22	M3AA 200 MLB	980	91.6	0.81	45	985	91.8	0.79	42	0.43	185	63
30	M3AA 225 SMB	985	92.6	0.83	59	985	92.9	0.82	55	0.64	225	63
37	M3AA 250 SMA	985	93.5	0.84	72	990	93.8	0.81	67	1.16	280	63
45	M3AA 280 SMA	985	93.8	0.86	85	985	94.2	0.83	80	1.49	375	63
<b>1000 r/min = 6 poles</b>		<b>380 V 50 Hz</b>				<b>415 V 50 Hz</b>				<b>High-output design</b>		
0.15	M2VA 63 BB	895	55.9	0.59	0.71	915	53.9	0.52	0.8	0.00032	5	38
0.32	M2VA 71 C	910	65.6	0.67	1.1	930	63.3	0.59	1.2	0.0011	7	42
1.3	<sup>1)</sup> M3AA 90 LB	900	69.0	0.75	3.8	920	69.0	0.67	3.9	0.0048	18	44
2.2	<sup>1)</sup> M3AA 100 LC	930	76.0	0.75	5.9	940	77.0	0.67	5.9	0.009	26	49
3	<sup>1)</sup> M3AA 112 MB	925	79.5	0.79	7.3	940	80.0	0.73	7.2	0.018	33	54
6.3	<sup>1)</sup> M3AA 132 MC	960	84.8	0.75	14.5	965	84.6	0.71	14.4	0.049	59	61
14	<sup>1)</sup> M3AA 160 LB	955	88.7	0.79	30.5	965	89.2	0.75	29.5	0.127	117	62
18.5	<sup>1)</sup> M3AA 180 LB	965	90.0	0.81	39	965	90.8	0.78	36.5	0.237	160	59
30	<sup>1)</sup> M3AA 200 MLC	980	91.5	0.83	57	985	91.9	0.83	52	0.49	200	63
37	M3AA 225 SMC	980	93.0	0.83	72	985	93.2	0.81	68	0.75	252	63
45	M3AA 250 SMB	985	93.8	0.86	85	985	94.2	0.83	80	1.49	320	63

### Recalculation factors

Recalculation factors for current at rated voltages other than 400 V 50 Hz.

Rated voltage at 50 Hz and motor wound for	Recalculation factor	Rated voltage at 50 Hz and motor wound for	Recalculation factor
220 V	1.82	500 V	0.80
230 V	1.74	660 V	0.61
415 V	0.96	690 V	0.58

# General purpose aluminium motors

## Technical data for totally enclosed squirrel cage three phase motors

IP 55 – IC 411 – Insulation class F, temperature rise class B

Output kW	Motor type	Product code	Speed r/min	Efficiency		Power factor cos φ	Current		Torque			
				Full load 100%	3/4 load 75%		$I_N$	$I_s$	$T_N$	$T_s$	$T_{max}$	
							A		Nm			
<b>750 r/min = 8 poles</b>			<b>400 V 50 Hz</b>				<b>Basic design</b>					
0.055	M2VA 63 B	3GVA 064 002-••	680	38.3	31.8	0.48	0.45	1.8	0.78	2.1	2.1	
0.09	M2VA 71 A	3GVA 074 001-••	690	45.8	37.5	0.57	0.52	2.2	1.25	2.3	2.3	
0.12	M2VA 71 B	3GVA 074 002-••	690	46.4	38.1	0.55	0.69	2.2	1.67	2.5	2.5	
0.18	M2VA 80 A	3GVA 084 001-••	700	59.9	54.5	0.60	0.75	3.1	2.46	3.2	3.6	
0.25	M2VA 80 B	3GVA 084 002-••	700	70.7	67.4	0.62	0.85	3.1	3.52	2.9	3.1	
0.37	M3AA 90 S	3GAA 094 001-••E	700	61.5	43.4	0.56	1.6	3.0	5	1.9	2.4	
0.55	M3AA 90 L	3GAA 094 002-••E	690	62.9	56.4	0.57	2.35	3.0	7.5	1.7	2.1	
0.75	M3AA 100 LA	3GAA 104 001-••E	700	72.0	63.6	0.59	2.55	3.5	10	2.1	2.7	
1.1	M3AA 100 LB	3GAA 104 002-••E	700	73.0	68.8	0.64	3.35	3.5	15	2.1	2.7	
1.5	M3AA 112 M	3GAA 114 001-••C	695	74.5	74.6	0.65	4.5	4.1	21	1.9	2.5	
2.2	M3AA 132 S	3GAA 134 001-••C	720	80.5	80.2	0.67	5.9	5.3	29	1.9	2.5	
3	M3AA 132 M	3GAA 134 002-••C	720	82.0	82.0	0.68	7.8	5.5	40	2.4	2.6	
4	M3AA 160 MA	3GAA 164 101-••C	715	84.1	84.7	0.69	10	5.2	54	2.1	2.4	
5.5	M3AA 160 M	3GAA 164 102-••C	710	84.7	85.5	0.70	13.4	5.4	74	2.4	2.6	
7.5	M3AA 160 L	3GAA 164 103-••C	715	86.3	87.2	0.70	18.1	5.4	100	2.4	2.8	
11	M3AA 180 L	3GAA 184 101-••C	720	88.7	89.2	0.76	23.5	5.9	146	2.4	2.6	
15	M3AA 200 MLA	3GAA 204 001-••C	740	91.1	91.1	0.82	29	7.4	194	1.8	3.0	
18.5	M3AA 225 SMA	3GAA 224 001-••C	730	91.1	91.1	0.79	37	6.2	242	1.9	2.7	
22	M3AA 225 SMB	3GAA 224 002-••C	730	91.5	91.5	0.77	45	6.0	288	1.9	2.7	
30	M3AA 250 SMA	3GAA 254 001-••C	735	92.8	92.8	0.79	59	6.9	390	1.9	2.9	
37	M3AA 280 SMA	3GAA 284 001-••C	735	93.2	93.2	0.81	71	7.2	481	2.0	2.9	
<b>750 r/min = 8 poles</b>			<b>400 V 50 Hz</b>				<b>High-output design</b>					
0.75	<sup>1)</sup> M3AA 90 LB	3GAA 094 003-••E	680	64.0	60.0	0.65	2.65	3.0	10	1.8	2.0	
1.5	<sup>1)</sup> M3AA 100 LC	3GAA 104 003-••E	670	71.0	65.9	0.70	4.4	3.3	21	1.8	2.2	
1.9	<sup>1)</sup> M3AA 112 MB	3GAA 114 002-••C	690	74.0	74.8	0.67	5.6	4.3	26.5	2.0	2.6	
3.8	<sup>1)</sup> M3AA 132 MB	3GAA 134 003-••C	710	80.5	80.7	0.69	9.9	5.2	51	2.3	2.6	
8.5	<sup>1)</sup> M3AA 160 LB	3GAA 164 104-••C	700	83.5	85.0	0.70	21	5.1	115	2.4	2.5	
15	<sup>1)</sup> M3AA 180 LB	3GAA 184 102-••C	720	88.0	89.2	0.76	32.5	6.0	199	2.5	2.6	
18.5	M3AA 200 MLB	3GAA 204 002-••C	735	91.4	91.4	0.81	36	6.7	237	1.7	2.8	
30	<sup>1)</sup> M3AA 225 SMC	3GAA 224 003-••C	735	91.8	91.8	0.79	60	7.2	390	2.1	3.3	
37	M3AA 250 SMB	3GAA 254 002-••C	735	93.2	93.2	0.81	71	7.2	481	2.0	2.9	

<sup>1)</sup> Temperature rise class F.

The bullets in the product code indicate choice of mounting arrangement, voltage and frequency, generation code (see ordering information page).

# General purpose aluminium motors

## Technical data for totally enclosed squirrel cage three phase motors

IP 55 – IC 411 – Insulation class F, temperature rise class B

Output kW	Motor type	Speed r/min	Efficiency %	Power factor cos φ	Current I <sub>N</sub> A	Speed r/min	Efficiency %	Power factor cos φ	Current I <sub>N</sub> A	Moment of inertia J = ¼ GD <sup>2</sup> kgm <sup>2</sup>	Weight kg	Sound pressure level L <sub>p</sub> dB(A)
<b>750 r/min = 8 poles</b>		<b>380 V 50 Hz</b>				<b>415 V 50 Hz</b>				<b>Basic design</b>		
0.055	M2VA 63 B	675	41.2	0.50	0.41	690	35.7	0.44	0.5	0.00027	4.5	36
0.09	M2VA 71 A	680	46.3	0.60	0.5	700	43.8	0.53	0.55	0.00063	5.5	40
0.12	M2VA 71 B	680	47.7	0.59	0.65	700	44.4	0.53	0.7	0.00081	6.5	40
0.18	M2VA 80 A	690	61.1	0.64	0.7	705	57.8	0.57	0.77	0.001842	9	45
0.25	M2VA 80 B	675	70.2	0.66	0.84	690	69.6	0.58	0.87	0.002176	10	45
0.37	M3AA 90 S	690	62.7	0.59	1.57	700	60.5	0.54	1.7	0.0032	13	43
0.55	M3AA 90 L	680	64.9	0.61	2.27	690	61.5	0.55	2.43	0.0043	16	43
0.75	M3AA 100 LA	690	72.0	0.63	2.5	700	71.0	0.55	2.7	0.0069	20	46
1.1	M3AA 100 LB	700	74.0	0.68	3.3	710	73.0	0.60	3.5	0.0082	23	46
1.5	M3AA 112 M	685	74.0	0.69	4.6	700	74.0	0.61	4.7	0.016	28	52
2.2	M3AA 132 S	715	80.0	0.71	5.9	725	80.0	0.65	5.9	0.038	46	56
3	M3AA 132 M	715	82.0	0.72	7.8	720	82.0	0.68	7.7	0.045	53	56
4	M3AA 160 MA	710	83.8	0.71	10.2	720	84.5	0.66	9.9	0.072	75	59
5.5	M3AA 160 M	705	84.0	0.72	13.8	715	85.0	0.68	13.3	0.091	88	59
7.5	M3AA 160 L	710	85.7	0.72	18.6	715	86.6	0.68	17.8	0.131	118	59
11	M3AA 180 L	715	88.2	0.77	24.5	720	89.0	0.75	23	0.224	147	59
15	M3AA 200 MLA	735	91.0	0.83	30	740	91.2	0.79	29	0.45	175	60
18.5	M3AA 225 SMA	730	91.0	0.79	39	735	91.3	0.76	36	0.61	210	63
22	M3AA 225 SMB	730	91.4	0.81	45	735	91.5	0.76	44	0.68	225	63
30	M3AA 250 SMA	735	92.6	0.81	61	740	92.9	0.77	58	1.25	280	63
37	M3AA 280 SMA	735	92.5	0.82	74	735	93.2	0.81	71	1.52	375	63
<b>750 r/min = 8 poles</b>		<b>380 V 50 Hz</b>				<b>415 V 50 Hz</b>				<b>High-output design</b>		
0.75 <sup>1)</sup>	M3AA 90 LB	670	64.0	0.69	2.6	690	63.0	0.61	2.7	0.0048	18	43
1.5 <sup>1)</sup>	M3AA 100 LC	660	71.0	0.73	4.5	675	70.0	0.65	4.6	0.009	26	46
1.9 <sup>1)</sup>	M3AA 112 MB	680	73.8	0.71	5.9	695	73.6	0.65	5.8	0.018	33	52
3.8 <sup>1)</sup>	M3AA 132 MB	705	80.0	0.72	10	715	80.5	0.67	9.9	0.049	59	56
8.5 <sup>1)</sup>	M3AA 160 LB	695	81.7	0.73	21.5	705	83.8	0.68	21	0.131	118	62
15 <sup>1)</sup>	M3AA 180 LB	715	87.6	0.78	33.5	720	88.3	0.74	32	0.24	155	62
18.5	M3AA 200 MLB	735	91.2	0.83	37	735	91.6	0.79	35	0.54	200	60
30 <sup>1)</sup>	M3AA 225 SMC	730	91.7	0.80	62	735	91.9	0.77	61	0.8	255	63
37	M3AA 250 SMB	735	92.5	0.82	74	735	93.2	0.81	71	1.52	320	63

### Recalculation factors

Recalculation factors for current at rated voltages other than 400 V 50 Hz.

Rated voltage at 50 Hz and motor wound for	Recalculation factor	Rated voltage at 50 Hz and motor wound for	Recalculation factor
220 V	1.82	500 V	0.80
230 V	1.74	660 V	0.61
415 V	0.96	690 V	0.58

# General purpose aluminium motors, premium efficiency

## Data acc. to IEC 60034-2, determination of efficiency

IP 55 – IC 411 – Insulation class F, temperature rise class B

Output kW	Type designation	Product code	Speed r/min	Efficiency		Power factor cos φ 100%	Current		Torque			Moment of inertia J=1/4 GD <sup>2</sup> kgm <sup>2</sup>	Weight kg	Sound pressure level LP dB(A)
				Full load 100%	3/4 load 75%		I <sub>N</sub>	I <sub>s</sub>	T <sub>N</sub>	T <sub>s</sub>	T <sub>max</sub>			
<b>3000 r/min = 2 poles</b>			<b>400 V 50 Hz</b>				<b>Basic design</b>							
4	M3AA 112 M	3GAA 111 022-••C	2860	87.7	88.9	0.93	7.1	7.5	13.4	2.6	3.4	0.012	33	63
5.5	M3AA 132 SA	3GAA 131 023-••C	2900	89.4	89.5	0.88	10.3	9.9	18.1	4.0	4.5	0.016	42	69
7.5	M3AA 132 SB	3GAA 131 024-••C	2915	90.9	91.3	0.90	13.3	11.0	24.6	5.1	5.2	0.022	56	69
11	M3AA 160 MA	3GAA 161 121-••C	2935	92.1	92.3	0.90	19.2	7.5	36	2.7	3.0	0.047	84	69
15	M3AA 160 M	3GAA 161 122-••C	2940	92.9	93.1	0.90	26	8.0	49	3.0	3.3	0.053	94	69
18.5	M3AA 160 L	3GAA 161 123-••C	2935	93.2	93.4	0.89	32.5	8.3	60	2.7	3.2	0.058	100	69
22	M3AA 180 M	3GAA 181 121-••C	2945	93.6	93.9	0.91	37.5	7.2	71	2.7	3.0	0.092	137	70
30	M3AA 200 MLB	3GAA 201 021-••C	2950	93.8	93.8	0.90	52	7.7	97	3.0	2.9	0.18	200	72
37	M3AA 200 MLC	3GAA 201 022-••C	2960	94.6	94.6	0.89	64	8.5	120	3.5	3.3	0.19	205	72
45	M3AA 225 SMC	3GAA 221 021-••C	2970	94.7	94.7	0.88	78	6.9	145	2.4	2.9	0.29	260	74
55	M3AA 250 SMB	3GAA 251 021-••C	2970	94.8	94.6	0.91	93	7.6	177	2.6	2.9	0.57	330	75
75	M3AA 250 SMC	3GAA 251 022-••C	2965	95.1	95.1	0.92	125	8.6	242	2.3	2.8	0.6	345	75
<b>1500 r/min = 4 poles</b>			<b>400 V 50 Hz</b>				<b>Basic design</b>							
3	M3AA 112 MA	3GAA 112 021-••C	1450	87.5	87.8	0.81	6.2	7.9	19.7	2.7	3.7	0.018	34	56
4	M3AA 112 M	3GAA 112 022-••C	1455	88.8	88.9	0.76	8.6	8.5	26.2	3.4	4.3	0.018	34	56
5.5	M3AA 132 S	3GAA 132 023-••C	1460	89.3	89.7	0.84	10.6	7.6	36	2.2	3.4	0.038	48	59
7.5	M3AA 132 M	3GAA 132 024-••C	1450	90.1	90.5	0.87	14	8.4	49	2.4	2.8	0.048	59	59
11	M3AA 160 M	3GAA 162 121-••C	1470	92.0	92.5	0.83	21	7.8	72	3.3	3.3	0.091	94	62
15	M3AA 160 L	3GAA 162 122-••C	1460	92.1	93.5	0.83	28.5	7.6	98	3.3	3.2	0.102	103	62
18.5	M3AA 180 M	3GAA 182 121-••C	1470	93.3	93.9	0.84	34	6.7	120	2.8	2.8	0.191	141	62
22	M3AA 180 L	3GAA 182 122-••C	1475	93.9	94.3	0.84	41	7.8	143	3.2	3.4	0.225	161	62
30	M3AA 200 MLB	3GAA 202 021-••C	1475	94.2	94.4	0.84	55	8.1	194	3.9	3.2	0.34	205	63
37	M3AA 225 SMB	3GAA 222 021-••C	1480	94.3	94.4	0.85	68	7.9	239	3.7	3.0	0.42	230	66
45	M3AA 225 SMC	3GAA 222 022-••C	1480	95.0	95.0	0.86	80	7.9	290	3.7	3.2	0.49	265	66
55	M3AA 225 SMD	3GAA 222 023-••C	1480	95.1	95.1	0.86	98	9.3	355	4.3	3.3	0.56	290	66
55	M3AA 250 SMB	3GAA 252 021-••C	1480	95.1	95.3	0.87	96	7.5	355	3.0	3.1	0.88	335	67
75	M3AA 250 SMC	3GAA 252 022-••C	1480	95.3	95.3	0.85	135	8.5	484	3.1	3.1	0.95	360	66

The bullets in the product code indicate choice of mounting arrangement, voltage and frequency, generation code (see ordering information page).

# General purpose aluminium motors, premium efficiency

Data acc. to IEC 60034-2, determination of efficiency

IP 55 – IC 411 – Insulation class F, temperature rise class B

Output kW	Type designation	Product code	Speed r/min	Efficiency		Power factor cos φ	Current		Torque			Moment of inertia		Weight kg	Sound pressure level LP dB(A)
				Full load 100%	3/4 load 75%		I <sub>N</sub>	I <sub>s</sub>	T <sub>N</sub>	T <sub>s</sub>	T <sub>max</sub>	J=1/4 GD <sup>2</sup>	kgm <sup>2</sup>		
<b>1000 r/min = 6 poles</b>			<b>400 V 50 Hz</b>			<b>Basic design</b>									
2.2	M3AA 112 M	3GAA 113 022-••C	945	83.6	84.2	0.74	5.2	6.0	22.2	2.4	2.9	0.018	33	<sup>1)</sup>	
3	M3AA 132 S	3GAA 133 024-••C	965	86.7	87.1	0.79	6.4	6.9	29.7	2.4	2.9	0.038	46	<sup>1)</sup>	
4	M3AA 132 MA	3GAA 133 025-••C	960	87.4	88.2	0.80	8.3	7.0	39.7	2.9	2.9	0.045	54	<sup>1)</sup>	
5.5	M3AA 132 MB	3GAA 133 026-••C	960	87.0	87.6	0.77	12	6.9	54	2.4	2.8	0.049	59	<sup>1)</sup>	
7.5	M3AA 160 M	3GAA 163 121-••C	975	90.7	91.1	0.77	15.6	7.8	74	2.2	3.5	0.107	102	<sup>1)</sup>	
11	M3AA 160 L	3GAA 163 122-••C	970	90.9	91.5	0.78	23	7.6	109	2.8	3.4	0.127	117	<sup>1)</sup>	
15	M3AA 180 L	3GAA 183 121-••C	980	92.2	92.4	0.77	31	8.3	147	2.5	3.9	0.237	160	<sup>1)</sup>	
18.5	M3AA 200 MLB	3GAA 203 021-••C	985	92.4	92.4	0.81	36	8.0	179	4.3	3.5	0.43	185	<sup>1)</sup>	
22	M3AA 200 MLC	3GAA 203 022-••C	985	92.9	93.0	0.82	42	8.1	214	4.3	3.2	0.49	200	<sup>1)</sup>	
30	M3AA 225 SMC	3GAA 223 021-••C	985	93.6	93.8	0.83	56	7.5	291	3.8	2.9	0.75	252	<sup>1)</sup>	
37	M3AA 250 SMB	3GAA 253 021-••C	990	94.4	94.4	0.82	69	8.3	357	4.2	2.4	1.49	320	<sup>1)</sup>	
<b>750 r/min = 8 poles</b>			<b>400 V 50 Hz</b>			<b>Basic design</b>									
1.5	M3AA 112 M	3GAA 114 022-••C	695	74.6	75.5	0.69	4.3	4.0	20.7	1.6	2.2	0.018	33	<sup>1)</sup>	
2.2	M3AA 132 S	3GAA 134 023-••C	725	83.7	83.3	0.66	5.9	5.6	29.1	2.1	3.0	0.045	53	<sup>1)</sup>	
3	M3AA 132 M	3GAA 134 024-••C	715	82.8	83.1	0.69	7.7	5.2	40.1	2.3	2.6	0.049	59	<sup>1)</sup>	
4	M3AA 160 MA	3GAA 164 121-••C	720	86.3	87.1	0.69	9.8	5.2	53	2.2	2.6	0.091	88	<sup>1)</sup>	
5.5	M3AA 160 M	3GAA 164 122-••C	725	86.9	87.3	0.66	14.1	6.0	73	2.3	3.1	0.131	118	<sup>1)</sup>	
7.5	M3AA 160 L	3GAA 164 123-••C	715	87.0	87.7	0.70	18.2	5.4	100	2.1	2.7	0.131	118	<sup>1)</sup>	
11	M3AA 180 L	3GAA 184 121-••C	<sup>1)</sup>												
15	M3AA 200 MLB	3GAA 204 021-••C	735	92.1	92.5	0.81	29	7.8	195	3.1	3.4	0.54	200	<sup>1)</sup>	
18.5	M3AA 225 SMB	3GAA 224 021-••C	735	92.4	92.8	0.76	38	6.5	240	2.6	3.0	0.68	225	<sup>1)</sup>	
22	M3AA 225 SMC	3GAA 224 022-••C	735	92.5	92.8	0.75	46	7.1	286	3.0	3.4	0.8	255	<sup>1)</sup>	
30	M3AA 250 SMB	3GAA 254 021-••C	740	93.6	94.0	0.78	60	7.6	388	2.8	3.3	1.52	320	<sup>1)</sup>	

<sup>1)</sup> On request.

The bullets in the product code indicate choice of mounting arrangement, voltage and frequency, generation code (see ordering information page).

# Data at voltage ranges



## Rated data at voltage codes S and D

Single-speed motors of size 112 to 132 can be produced with voltage codes S and D, i.e., voltage range at both 50 and 60 Hz. The current rating for each voltage range is specified on the rating plate. It represents the highest

current that can exist within the voltage range at the rated output. The power factor and speed specified on the rating plate apply at the average voltage within the range.

Output in kW		Design <sup>4)</sup>	Motor type	Product code 3GAA	Current in A <sup>2)</sup> at		Speed in r/min		Power factor cos φ	
50 Hz	60 Hz				380-420 V 50 Hz	440-480 V 60 Hz	380-420 V 50 Hz	440-480 V 60 Hz	380-420 V 50 Hz	440-480 V 60 Hz
<b>3000/3600 r/min = 2 poles</b>										
4	4.6	<sup>5)</sup>	M2AA 112 M	111 001-••A	7.8	7.7	2850	3450	0.91	0.91
4	4.6		M3AA 112 M	111 022-••C	7.6	7.4	2860	3460	0.93	0.93
5.5	6.4	<sup>3)</sup> HO	M3AA 112 MB	111 002-••C	10.5	10.4	2855	3455	0.93	0.93
5.5	6.4	<sup>5)</sup>	M2AA 132 SA	131 001-••A	10.9	11	2855	3455	0.88	0.88
5.5	6.4		M3AA 132 SA	131 023-••C	10.7	10.7	2900	3500	0.88	0.87
7.5	8.6	<sup>5)</sup>	M2AA 132 SB	131 002-••A	14.7	14.4	2855	3455	0.90	0.90
7.5	8.6		M3AA 132 SB	131 024-••C	13.9	13.8	2915	3515	0.90	0.89
9.2	10.6	<sup>3)</sup> HO	M3AA 132 SBB	131 004-••C	17.6	17.3	2840	3440	0.92	0.92
11	12.6	<sup>3)</sup> HO	M3AA 132 SC	131 003-••C	21	20	2835	3445	0.93	0.93
<b>1500/1800 r/min = 4 poles</b>										
3	3.5		M3AA 112 MA	112 021-••C	6.5	6.4	1450	1750	0.81	0.8
4	4.6	<sup>5)</sup>	M2AA 112 M	112 001-••A	8.9	8.6	1435	1735	0.80	0.81
4	4.6		M3AA 112 M	112 022-••C	9	8.6	1455	1755	0.76	0.76
5.5	6.4	<sup>3)</sup> HO	M3AA 112 MB	112 002-••C	11.7	11.6	1425	1725	0.83	0.83
5.5	6.4	<sup>5)</sup>	M2AA 132 S	132 001-••A	11.5	11.5	1450	1750	0.83	0.83
5.5	6.4		M3AA 132 S	132 023-••C	11.1	11.1	1460	1760	0.84	0.84
7.5	8.6	<sup>5)</sup>	M2AA 132 M	132 002-••A	15.3	15.1	1450	1750	0.83	0.83
7.5	8.6		M3AA 132 M	132 024-••C	14.6	14.3	1450	1750	0.87	0.86
9.2	10.6	<sup>3)</sup> HO	M3AA 132 MBA	132 004-••C	18.4	18.2	1445	1745	0.87	0.87
11	12.6	<sup>3)</sup> HO	M3AA 132 MB	132 003-••C	22	22	1450	1750	0.86	0.86

<sup>2)</sup> Recalculation factors

Multiple by 1.73 when recalculating:

from 380-420 V to 220-240 V 50 Hz

from 440-480 V to 250-280 V 50 Hz

<sup>3)</sup> Class F temperature rise

<sup>4)</sup> High-output design.

<sup>5)</sup> Efficiency class eff2.

# Data at voltage ranges

## Rated data at voltage codes S and D

Single-speed motors of size 112 to 132 can be produced with voltage codes S and D, i.e., voltage range at both 50 and 60 Hz. The current rating for each voltage range is specified on the rating plate. It represents the highest

current that can exist within the voltage range at the rated output. The power factor and speed specified on the rating plate apply at the average voltage within the range.

Output in kW		Design <sup>3)</sup>	Motor type	Product code 3GAA	Current in A <sup>1)</sup> at		Speed in r/min		Power factor cos $\phi$	
50 Hz	60 Hz				380-420 V 50 Hz	440-480 V 60 Hz	380-420 V 50 Hz	440-480 V 60 Hz	380-420 V 50 Hz	440-480 V 60 Hz
<b>1000/1200 r/min = 6 poles</b>										
2.2	2.5		M3AA 112 M	113 001-∞C	5.4	5.3	940	1140	0.74	0.74
3.0	3.5	HO	M3AA 112 MB	113 002-∞C	7.3	7.3	935	1135	0.76	0.75
3.0	3.5		M3AA 132 S	133 001-∞C	7.1	7.0	960	1160	0.75	0.75
4.0	4.6		M3AA 132 MA	133 002-∞C	8.9	8.9	960	1160	0.78	0.78
5.5	6.4		M3AA 132 MB	133 003-∞C	12.2	12.2	955	1155	0.78	0.78
6.5	7.5	HO	M3AA 132 MC	133 004-∞C	15.2	14.9	960	1160	0.75	0.76
<b>750/900 r/min = 8 poles</b>										
1.5	1.7		M3AA 112 M	114 001-∞C	4.6	4.4	695	845	0.65	0.65
2.0	2.3	HO	M3AA 112 MB	114 002-∞C	6	6	685	835	0.67	0.66
2.2	2.5		M3AA 132 S	134 001-∞C	5.9	5.9	720	870	0.67	0.66
3.0	3.5		M3AA 132 M	134 002-∞C	7.8	7.8	720	870	0.68	0.68
3.8	4.4	HO	M3AA 132 MB	134 003-∞C	10	10	710	860	0.69	0.69

<sup>1)</sup> Recalculation factors.

Multiply by 1.73 when recalculating:  
 from 380-420 V to 220-240 V 50 Hz  
 from 440-480 V to 250-280 V 60 Hz

<sup>2)</sup> Class F temperature rise.

<sup>3)</sup> High-output design.

# General purpose aluminium motors

## Technical data for totally enclosed squirrel cage three phase motors, two-speed

IP 55 – IC 411 – Insulation class F, temperature rise class F

Output kW	Motor type	Product code	Speed r/min	Efficiency %	Power factor cos φ	Current		Torque			Moment of inertia	
						I <sub>N</sub> A	I <sub>s</sub> I <sub>N</sub>	T <sub>N</sub> Nm	T <sub>s</sub> T <sub>N</sub>	T <sub>max</sub> T <sub>N</sub>	J = ¼ GD <sup>2</sup> kgm <sup>2</sup>	Weight kg
<b>3000/1500 r/min = 2/4 poles</b>			<b>400 V 50 Hz</b>			<b>Fan drive, two separate windings</b>						
0.65/0.14	M3VA 80 A	3GVA 087 121-••B	2860/1450	73.0/57.0	0.85/0.63	1.5/0.58	4.8/3.6	2.18/0.93	1.9/2.0	2.2/2.3	0.0008	9
0.95/0.20	M3VA 80 B	3GVA 087 122-••B	2850/1440	75.0/61.0	0.87/0.69	2.1/0.7	5.0/3.7	3.19/1.33	2.0/1.8	2.2/2.2	0.0009	11
1.1/0.25	M3VA 80 C	3GVA 087 123-••B	2860/1440	77.0/63.0	0.87/0.70	2.4/0.85	5.3/3.8	3.7/1.7	2.0/1.8	2.2/2.0	0.0012	12
1.40/0.22	M3AA 90 S	3GAA 098 201-••E	2870/1470	77.0/48.0	0.87/0.63	3.0/1.1	5.3/3.3	4.6/1.4	1.7/1.0	2.4/2.3	0.0019	13
1.9/0.3	M3AA 90 L	3GAA 098 202-••E	2880/1470	78.0/53.0	0.87/0.68	4.0/1.1	5.8/3.7	6.3/1.9	1.9/1.0	2.5/2.3	0.0024	16
2.5/0.4	M3AA 100 L	3GAA 108 201-••E	2900/1470	80.0/60.0	0.87/0.67	5.2/1.5	6.5/4.1	8.2/2.6	2.1/1.0	3.0/2.7	0.0041	21
3.5/0.6	M3AA 112 M	3GAA 118 204-••C	2895/1470	83.0/68.0	0.92/0.60	6.6/2.1	7.0/5.8	11.5/3.9	1.7/1.8	2.3/2.8	0.012	32
5.5/1	M3AA 132 S	3GAA 138 207-••C	2900/1470	84.0/64.0	0.88/0.65	10.8/3.5	7.8/5.7	18.1/6.5	2.4/2.0	2.9/2.8	0.016	42
7.4/1.2	M3AA 132 M	3GAA 138 208-••C	2875/1475	85.0/67.0	0.93/0.64	13.5/4.1	7.5/5.9	24.6/7.8	2.1/2.0	2.6/2.8	0.022	56
13/1.9	M3AA 160 M	3GAA 168 352-••C	2940/1470	88.5/79.5	0.92/0.79	23/4.4	7.8/6.4	42/12	2.1/2.1	3.0/2.5	0.054	92
17.5/2.5	M3AA 160 L	3GAA 168 353-••C	2925/1475	89.0/81.0	0.92/0.77	31/5.8	7.1/6.7	57/16	2.0/2.5	2.6/2.9	0.057	99
20/2.8	M3AA 180 M	3GAA 188 357-••C	2930/1465	89.0/77.0	0.90/0.77	36/6.9	6.4/5.8	65/18	2.1/1.9	2.4/2.0	0.094	132
25/3.6	M3AA 180 L	3GAA 188 358-••C	2940/1465	90.0/78.0	0.88/0.78	46/8.6	7.5/7.3	81/24	2.6/1.9	2.9/1.9	0.108	152
30/4.1	M3AA 200 MLA	3GAA 208 210-••C	2945/1480	91.5/85.0	0.89/0.72	54/10	8.0/7.1	97/26	2.2/2.7	2.8/2.8	0.15	175
38/5.5	M3AA 200 MLB	3GAA 208 211-••C	2945/1480	92.5/86.5	0.91/0.74	67/13	7.7/6.8	123/35	2.2/2.6	2.6/2.6	0.19	205
43/6	M3AA 225 SMB	3GAA 228 207-••C	2950/1475	92.5/86.5	0.90/0.78	75/13	7.1/5.8	139/39	2.3/2.7	2.4/2.0	0.26	235
50/7	M3AA 225 SMC	3GAA 228 208-••C	2955/1480	93.0/87.5	0.91/0.78	86/15	7.3/6.1	162/45	2.4/2.9	2.4/2.1	0.29	260
70/10	M3AA 250 SMB	3GAA 258 204-••C	2965/1485	94.0/89.5	0.90/0.76	119/22	9.3/7.1	225/64	2.3/2.5	3.1/2.3	0.57	330
<b>3000/1500 r/min = 2 - 4 poles</b>			<b>400 V 50 Hz</b>			<b>Fan drive, Dahlander-connection</b>						
0.22/0.044	M3VA 63 A	3GVA 068 121-••A	2700/1400	65.0/50.0	0.76/0.65	0.65/0.20	3.3/3.1	0.78/0.30	1.9/2.3	1.9/2.3	0.00019	4
0.33/0.07	M3VA 63 B	3GVA 068 122-••A	2700/1380	65.0/52.0	0.82/0.77	0.90/0.25	3.1/3.1	1.17/0.49	1.6/2.0	1.6/2.0	0.00026	4.5
0.37/0.08	M3VA 71 A	3GVA 078 121-••B	2700/1380	65.0/58.0	0.92/0.81	0.90/0.25	2.8/3.1	1.31/0.56	1.6/1.9	1.6/1.9	0.00066	5.5
0.55/0.12	M3VA 71 B	3GVA 078 122-••B	2700/1380	69.0/68.0	0.95/0.85	1.2/0.3	3.0/3.0	1.95/0.84	1.6/1.9	1.6/1.9	0.00089	6.5
0.65/0.13	M3VA 71 C	3GVA 078 123-••B	2700/1400	69.0/65.0	0.92/0.73	1.5/0.4	3.9/4.1	2.3/0.88	1.9/2.6	2.1/2.8	0.00110	7
0.85/0.20	M3VA 80 A	3GVA 088 121-••B	2790/1420	75.0/63.0	0.87/0.66	1.9/0.70	5.0/4.1	2.91/1.35	2.1/2.3	2.3/2.6	0.00080	9
1.1/0.25	M3VA 80 B	3GVA 088 122-••B	2850/1450	79.0/64.0	0.84/0.63	2.4/0.90	5.3/4.2	3.7/1.65	2.3/2.5	2.5/2.7	0.00090	11
1.4/0.35	M3VA 80 C	3GVA 088 123-••B	2825/1415	78.0/64.0	0.87/0.68	3/1.18	5.4/4.4	4.75/2.37	2.3/2.4	2.4/2.6	0.00120	11.5
1.5/0.33	M3AA 90 S	3GAA 098 101-••E	2860/1460	77.0/66.0	0.87/0.67	3.3/1.1	5.2/3.9	5.0/2.1	1.8/1.1	2.4/2.1	0.0019	13
2.2/0.45	M3AA 90 L	3GAA 098 102-••E	2860/1460	80.0/73.0	0.88/0.65	4.6/1.4	5.9/4.4	7.3/2.9	2.1/1.2	2.6/2.3	0.0024	16
2.5/0.47	M3AA 90 LB	3GAA 098 103-••E	2860/1460	78.0/75.0	0.88/0.62	5.2/1.5	6.1/4.5	8.3/3.1	2.2/1.4	2.5/2.3	0.0027	18
3/0.6	M3AA 100 L	3GAA 108 101-••E	2880/1470	81.0/74.0	0.89/0.61	6.2/1.9	6.3/4.8	9.9/3.9	2.2/1.4	2.8/2.8	0.0041	21
3.5/0.7	M3AA 100 LB	3GAA 108 102-••A	2880/1470	80.0/77.0	0.91/0.65	7/2	6.2/4.8	12.0/4.6	2.1/1.2	2.6/3.0	0.005	25
4.5/1	M3AA 112 M	3GAA 118 104-••C	2875/1450	83.0/80.0	0.93/0.76	8.4/2.4	7.0/6.0	14.9/6.6	1.8/1.9	2.3/2.8	0.012	32
6.2/1.3	M3AA 132 S	3GAA 138 127-••C	2880/1455	84.0/80.0	0.91/0.67	11.8/3.5	7.0/6.5	20.6/8.5	2.0/2.6	2.6/3.3	0.016	42
8.3/1.7	M3AA 132 M	3GAA 138 108-••C	2875/1455	84.0/82.0	0.93/0.71	15.4/4.2	7.4/6.6	27.6/11.2	2.5/2.7	2.7/3.3	0.022	56
10/2	M3AA 160 MA	3GAA 168 301-••C	2910/1465	85.0/83.5	0.89/0.73	19/4.8	5.9/6.1	30/43	1.5/2.4	2.3/2.8	0.039	73
16/3.2	M3AA 160 M	3GAA 168 302-••C	2915/1465	87.5/86.5	0.92/0.76	28.5/7.0	6.6/6.3	52/21	1.8/2.5	2.4/2.8	0.054	92
19.5/4.5	M3AA 160 L	3GAA 168 303-••C	2930/1465	89.0/88.0	0.89/0.77	36/9.7	7.6/6.4	64/29	2.3/2.5	2.9/2.8	0.057	99
21.5/4.7	M3AA 180 M	3GAA 188 305-••C	2935/1465	90.0/88.0	0.91/0.77	38/10	7.0/5.3	70/28	2.1/2.1	2.6/2.3	0.094	132
26/5.2	M3AA 180 L	3GAA 188 306-••C	2940/1470	90.5/89.5	0.89/0.75	47/11	6.9/5.8	85/34	2.3/2.4	2.6/2.4	0.108	152
32/8	M3AA 200 MLA	3GAA 208 110-••C	2940/1465	90.0/89.5	0.89/0.85	58/16	7.1/6.2	104/52	2.0/2.0	2.5/2.2	0.28	180
39/10	M3AA 200 MLB	3GAA 208 111-••C	2950/1475	91.5/91.0	0.89/0.85	69/19	7.4/6.2	126/65	2.0/2.0	2.6/2.3	0.34	205
42/11	M3AA 200 MLC	3GAA 208 112-••C	2950/1470	92.5/91.0	0.89/0.77	75/23	7.7/5.6	136/71	2.2/2.1	3.0/2.5	0.19	205
45/13	M3AA 225 SMB	3GAA 228 107-••C	2955/1475	93.0/91.5	0.92/0.82	76/25	7.4/5.3	145/84	2.0/2.0	2.6/2.1	0.27	235
55/15	M3AA 225 SMC	3GAA 228 108-••C	2955/1475	93.5/92.5	0.91/0.82	94/29	7.3/5.4	178/97	2.0/2.0	2.6/2.2	0.3	260
75/25	M3AA 250 SMB	3GAA 258 104-••C	2965/1475	94.5/93.0	0.92/0.82	125/48	8.9/5.5	241/162	2.3/2.0	3.1/2.2	0.36	330

Data for motor size 280 on request.

The bullets in the product code indicate choice of mounting arrangement, voltage and frequency, generation code (see ordering information page).



# General purpose aluminium motors

## Technical data for totally enclosed squirrel cage three phase motors, two-speed

IP 55 – IC 411 – Insulation class F, temperature rise class F

Output kW	Motor type	Product code	Speed r/min	Efficiency %	Power factor cos φ	Current		Torque			Moment of inertia	
						I <sub>N</sub> A	I <sub>s</sub> I <sub>N</sub>	T <sub>N</sub> Nm	T <sub>s</sub> T <sub>N</sub>	T <sub>max</sub> T <sub>N</sub>	J = ¼ GD <sup>2</sup> kgm <sup>2</sup>	Weight kg
<b>1500/750 r/min = 4/8 poles</b>			<b>400 V 50 Hz</b>			<b>Fan drive, two-separate windings</b>						
0.48/0.075	M3VA 80 A	3GVA 087 241-→B	1400/710	66.0/33.0	0.80/0.55	1.3/0.60	3.4/2.4	3.3/1	1.7/2.2	1.7/2.6	0.0013	9
0.63/0.10	M3VA 80 B	3GVA 087 242-→B	1400/710	68.0/40.0	0.81/0.50	1.65/0.75	3.7/2.5	4.4/1.35	1.8/2.3	1.8/2.6	0.0016	11
0.73/0.12	M3VA 80 C	3GVA 087 243-→B	1405/710	70.0/42.0	0.80/0.50	1.9/0.85	4.1/2.6	5/1.7	2.0/2.3	2.0/2.5	0.0020	12
1/0.13	M3AA 90 S	3GAA 098 207-→E	1400/700	71.0/38.0	0.83/0.70	2.6/0.72	3.9/2.1	6.8/1.8	1.5/1.0	2.0/1.7	0.0032	13
1.4/0.18	M3AA 90 L	3GAA 098 208-→E	1420/710	74.0/41.0	0.81/0.60	3.5/1.1	4.5/2.3	9.4/2.4	1.7/1.1	2.3/2.1	0.0043	16
1.85/0.25	M3AA 100 LA	3GAA 108 206-→E	1430/720	78.0/45.0	0.84/0.60	4.2/1.4	4.9/2.5	12/3.3	1.7/1.1	2.3/2.1	0.0069	20
2.3/0.33	M3AA 100 LB	3GAA 108 207-→E	1430/720	80.0/49.0	0.86/0.60	5.0/1.6	5.2/2.6	15/4.3	1.8/1.1	2.4/2.2	0.0082	23
3/0.4	M3AA 112 M	3GAA 118 206-→C	1440/730	81.0/51.0	0.87/0.58	6.2/2.0	6.8/3.8	19.9/5.2	1.5/1.6	2.4/2.6	0.018	32
4/0.6	M3AA 132 S	3GAA 138 231-→C	1465/740	84.0/51.0	0.84/0.53	8.2/3.2	6.5/3.5	26.1/7.7	1.5/1.1	2.4/2.5	0.038	48
5.5/0.9	M3AA 132 M	3GAA 138 232-→C	1455/735	84.0/53.0	0.87/0.64	10.9/3.9	6.2/3.1	36.1/11.7	1.5/1.1	2.2/2.0	0.048	59
9/1.3	M3AA 160 M	3GAA 168 356-→C	1460/735	87.0/60.0	0.84/0.53	18/5.9	6.6/4.0	59/17	2.0/2.2	2.5/2.7	0.089	92
13/1.8	M3AA 160 L	3GAA 168 357-→C	1455/735	88.0/64.0	0.85/0.53	26/8.2	6.0/4.1	89/26	1.9/2.2	2.3/2.6	0.119	117
16/2.3	M3AA 180 M	3GAA 188 361-→C	1475/740	88.5/64.0	0.82/0.53	32/9.7	6.8/4.1	104/30	2.2/2.2	2.7/2.6	0.176	130
19/2.7	M3AA 180 L	3GAA 188 362-→C	1475/740	89.5/68.0	0.83/0.54	37/10.5	7.5/7.2	123/35	2.6/2.6	2.9/2.6	0.224	159
26/3.3	M3AA 200 MLA	3GAA 208 216-→C	1475/740	91.0/73.0	0.85/0.59	49/11	6.9/4.6	168/46	2.1/2.2	2.5/2.3	0.28	180
30/3.8	M3AA 200 MLB	3GAA 208 217-→C	1470/740	91.5/75.5	0.86/0.59	55/12.5	6.7/4.6	195/49	2.1/2.2	2.4/2.2	0.34	205
38/5.2	M3AA 225 SMB	3GAA 228 211-→C	1480/740	91.5/80.5	0.84/0.63	72/15	7.3/5.2	245/67	2.1/2.3	2.6/2.3	0.41	230
46/7	M3AA 225 SMC	3GAA 228 212-→C	1480/740	92.5/82.0	0.86/0.66	85/19	7.7/4.9	297/90	2.3/2.1	2.7/2.1	0.49	265
63/10	M3AA 250 SMB	3GAA 258 206-→C	1475/740	93.5/83.0	0.89/0.65	110/27	7.5/6.0	408/129	2.4/3.3	2.7/2.7	0.89	335
<b>1500/750 r/min = 4-8 poles</b>			<b>400 V 50 Hz</b>			<b>Fan drive, Dahlander-connection</b>						
0.18/0.037	M3VA 71 A	3GVA 078 241-→B	1380/680	57.0/32.0	0.58/0.56	0.80/0.30	3.1/1.9	1.24/0.52	2.9/2.9	2.8/2.8	0.00066	5.5
0.37/0.09	M3VA 71 B	3GVA 078 242-→B	1380/630	66.0/41.0	0.73/0.63	1.1/0.5	3.1/1.7	2.6/1.37	2.1/1.8	2.1/1.8	0.00089	6.5
0.45/0.10	M3VA 71 C	3GVA 078 243-→B	1390/650	62.0/40.0	0.66/0.60	1.6/0.6	3.5/2.1	3.1/1.5	2.5/2.1	2.4/1.9	0.00110	7
0.55/0.13	M3VA 80 A	3GVA 088 241-→B	1400/680	64.0/45.0	0.70/0.60	1.8/0.70	3.8/2.4	3.75/1.83	2.2/1.6	2.2/1.6	0.00130	9
0.75/0.17	M3VA 80 B	3GVA 088 242-→B	1380/640	66.0/49.0	0.79/0.66	2.10/0.77	4.0/2.4	5.19/2.54	2.0/1.4	2.0/1.4	0.00160	10.5
0.90/0.20	M3VA 80 C	3GVA 088 243-→B	1390/650	69.0/47.0	0.76/0.62	2.5/1	4.3/2.5	6.19/2.94	2.3/1.5	2.3/2.5	0.00200	11
1.1/0.26	M3AA 90 S	3GAA 098 104-→E	1410/700	73.0/53.0	0.80/0.63	2.8/1.2	4.2/2.4	7.4/3.6	1.8/1.2	2.3/1.9	0.0032	13
1.7/0.35	M3AA 90 L	3GAA 098 105-→E	1390/700	74.0/57.0	0.82/0.57	4.0/1.6	4.5/2.5	10.3/4.7	2.2/1.5	2.6/2.1	0.0043	16
1.8/0.35	M3AA 90 LB	3GAA 098 106-→E	1400/710	76.0/60.0	0.83/0.56	4.2/1.5	4.3/2.7	12/4.8	1.9/1.6	2.3/2.3	0.0048	18
2.3/0.5	M3AA 100 LA	3GAA 108 103-→E	1415/715	76.0/63.0	0.84/0.60	5.2/1.9	4.6/2.7	15.5/6.7	1.8/1.2	2.4/1.9	0.0069	20
2.8/0.6	M3AA 100 LB	3GAA 108 104-→E	1430/720	81.0/68.0	0.82/0.58	6.4/2.2	5.2/3.0	18/8	2.0/1.2	2.6/2.2	0.0082	23
3/0.65	M3AA 100 LC	3GAA 108 105-→E	1430/720	81.0/67.0	0.81/0.56	6.8/2.5	5.6/3.0	20/8.7	2.2/1.3	2.8/2.3	0.009	26
3.5/0.7	M3AA 112 M	3GAA 118 126-→C	1430/720	81.0/71.0	0.89/0.58	7.0/2.5	6.8/4.4	23.4/9.3	1.6/1.7	2.5/2.7	0.018	32
5/1	M3AA 132 S	3GAA 138 131-→C	1450/725	83.0/74.0	0.87/0.59	9.9/3.3	6.4/3.6	32.9/13.2	1.5/1.0	2.3/2.0	0.038	48
6.8/1.4	M3AA 132 M	3GAA 138 132-→C	1460/730	85.0/73.0	0.84/0.55	13.7/5.1	7.6/3.6	44.5/18.3	2.0/1.4	2.8/2.7	0.048	59
10.5/2.2	M3AA 160 M	3GAA 168 304-→C	1460/735	87.5/79.0	0.84/0.54	21/7.4	6.9/3.7	69/29	2.2/1.5	2.7/2.3	0.089	94
15.5/2.7	M3AA 160 L	3GAA 168 305-→C	1460/735	88.5/79.5	0.85/0.51	30/9.5	6.9/3.9	101/35	2.2/1.7	2.6/2.6	0.119	117
17/3.4	M3AA 180 M	3GAA 188 307-→C	1470/730	88.5/78.0	0.85/0.56	33/11	5.8/4.3	111/44	1.7/1.2	2.3/1.9	0.176	137
22/4.4	M3AA 180 L	3GAA 188 308-→C	1475/735	89.5/79.0	0.83/0.53	43/15	6.7/3.9	143/57	2.0/1.7	2.6/2.3	0.224	161
29/6.5	M3AA 200 MLA	3GAA 208 116-→C	1470/730	90.5/86.0	0.86/0.64	54/17	6.9/4.2	188/81	2.2/1.9	2.4/1.9	0.28	180
33/8	M3AA 200 MLB	3GAA 208 117-→C	1475/730	91.5/86.5	0.86/0.64	61/21	7.8/4.2	214/105	2.6/1.9	2.6/1.8	0.34	205
42/10	M3AA 225 SMB	3GAA 228 111-→C	1480/740	92.0/89.5	0.86/0.64	85/27	7.8/5.0	271/129	2.5/2.2	3.0/2.3	0.49	265
50/11	M3AA 225 SMC	3GAA 228 112-→C	1465/735	92.5/89.5	0.87/0.65	91/28	7.3/4.7	324/143	2.3/2.0	2.5/2.0	0.49	265
60/15	M3AA 250 SMB	3GAA 258 106-→C	1475/735	93.0/90.0	0.86/0.70	104/34	7.9/4.7	388/195	2.6/2.1	2.7/2.0	0.89	335

# General purpose aluminium motors

## Technical data for totally enclosed squirrel cage three phase motors, two-speed

IP 55 – IC 411 – Insulation class F, temperature rise class F

Output kW	Motor type	Product code	Speed r/min	Efficiency %	Power factor cos φ	Current		Torque			Moment of inertia	
						I <sub>N</sub> A	I <sub>s</sub> I <sub>N</sub>	T <sub>N</sub> Nm	T <sub>s</sub> T <sub>N</sub>	T <sub>max</sub> T <sub>N</sub>	J = ¼ GD <sup>2</sup> kgm <sup>2</sup>	Weight kg
<b>1500/1000 r/min = 4/6 poles</b>			<b>400 V 50 Hz</b>			<b>Fan drive, two separate windings</b>						
0.18/0.05	M3VA 71 A	3GVA 077 231-**-B	1430/970	54.0/30.0	0.70/0.50	0.70/0.50	3.1/3.2	1.2/0.50	1.9/2.2	2.2/2.9	0.00066	5.5
0.30/0.10	M3VA 71 B	3GVA 077 232-**-B	1400/950	56.0/39.0	0.80/0.60	1/0.60	2.8/2.6	2.05/1.0	1.7/2.1	1.9/2.3	0.00089	6.5
0.50/0.19	M3VA 80 A	3GVA 087 231-**-B	1350/940	58.0/50.0	0.89/0.79	1.4/0.7	2.9/3.1	3.54/1.94	1.4/1.5	1.4/1.5	0.00190	9
0.66/0.25	M3VA 80 B	3GVA 087 232-**-B	1350/935	63.0/52.0	0.90/0.78	1.70/0.90	3.3/3.3	4.67/2.56	1.6/1.5	1.6/1.6	0.00220	10
0.78/0.30	M3VA 80 C	3GVA 087 233-**-B	1400/940	66.0/60.0	0.84/0.73	2.0/1.0	3.6/3.8	5.33/3.06	1.8/1.9	1.8/2.1	0.00250	10.5
1/0.3	M3AA 90 S	3GAA 098 204-**-E	1400/940	73.0/53.0	0.83/0.70	2.5/1.2	4.2/2.6	6.8/3.0	1.8/1.0	2.2/1.7	0.0032	13
1.5/0.45	M3AA 90 L	3GAA 098 205-**-E	1400/930	72.0/52.0	0.84/0.73	3.5/1.6	4.3/2.9	10/4.5	1.7/1.0	2.1/1.8	0.0043	16
2/0.6	M3AA 100 LA	3GAA 108 203-**-E	1430/960	77.0/62.0	0.85/0.72	4.5/2.0	5.0/3.3	13/5.9	1.8/1.0	2.4/1.9	0.0069	20
2.5/0.8	M3AA 100 LB	3GAA 108 204-**-A	1430/960	79.0/68.0	0.84/0.71	5.5/2.5	5.6/3.5	16/7.9	2.0/1.1	2.5/2.0	0.0082	23
3/1	M3AA 112 M	3GAA 118 205-**-C	1445/975	82.0/67.0	0.84/0.68	6.3/3.1	6.0/4.0	19.8/9.8	1.3/1.0	2.3/2.2	0.018	33
4.5/1.5	M3AA 132 S	3GAA 138 229-**-C	1460/985	83.0/67.0	0.85/0.64	9.2/5.1	6.5/4.2	29.4/14.5	1.5/1.0	2.3/2.2	0.038	48
6/2	M3AA 132 M	3GAA 138 230-**-C	1460/980	84.0/71.0	0.86/0.73	12/5.6	7.1/4.5	39.2/19.5	1.8/1.3	2.5/2.0	0.048	59
10.5/3.5	M3AA 160 M	3GAA 168 354-**-C	1460/965	87.0/75.5	0.84/0.78	21/8.6	6.4/4.1	69/35	2.0/1.3	2.5/1.7	0.089	93
14.5/4.5	M3AA 160 L	3GAA 168 355-**-C	1460/970	88.5/77.0	0.85/0.76	28/11	6.9/4.6	95/44	2.2/1.5	2.6/1.9	0.119	117
16/5	M3AA 180 M	3GAA 188 359-**-C	1470/980	89.0/78.0	0.83/0.73	31/12.5	6.3/4.6	104/49	1.9/1.5	2.5/2.0	0.176	131
20/6.5	M3AA 180 L	3GAA 188 360-**-C	1470/980	90.0/79.5	0.83/0.74	39/16	7.2/5.0	130/63	2.4/1.8	2.7/2.0	0.224	159
23/7.2	M3AA 200MLA	3GAA 208 213-**-C	1475/985	89.5/84.0	0.88/0.87	43/15	7.7/7.8	149/70	1.6/1.9	2.8/2.9	0.44	175
30/9	M3AA 200MLB	3GAA 208 214-**-C	1470/990	90.0/86.6	0.90/0.84	54/18.2	7.7/9.5	195/87	1.6/1.7	2.7/2.9	0.53	200
34/11	M3AA 225SMB	3GAA 228 209-**-C	1470/985	91.0/85.0	0.91/0.89	60/21	7.7/6.7	221/107	1.5/1.3	2.7/2.3	0.67	225
42/14	M3AA 225SMC	3GAA 228 210-**-C	1475/985	91.5/89.0	0.89/0.89	75/27	8.4/6.8	272/136	1.7/1.4	3.0/2.3	0.78	255
63/18.5	M3AA 250SMB	3GAA 258 205-**-C	1475/985	93.5/87.0	0.89/0.79	110/40	7.5/7.3	408/179	2.4/3.0	2.7/2.6	0.89	335
<b>1000/750 r/min = 6/8 poles</b>			<b>400 V 50 Hz</b>			<b>Fan drive, two separate windings</b>						
0.25/0.10	M3VA 80 A	3GVA 087 341-**-B	945/725	57.0/41.0	0.68/0.55	0.95/0.65	3.2/2.8	2.6/1.32	2.0/2.4	2.2/2.9	0.0019	9
0.33/0.14	M3VA 80 B	3GVA 087 342-**-B	940/720	62.0/46.0	0.74/0.56	1.05/0.8	3.4/3.1	3.36/1.86	1.9/2.5	1.9/3.0	0.0022	10
0.45/0.2	M3AA 90 S	3GAA 098 210-**-E	940/700	59.0/44.0	0.72/0.67	1.6/1.0	3.1/2.2	4.6/2.7	1.4/1.0	2.0/1.7	0.0032	13
0.70/0.3	M3AA 90 L	3GAA 098 211-**-E	930/690	63.0/45.0	0.75/0.64	2.2/1.5	3.1/2.3	7.2/4.1	1.3/1.1	1.8/1.8	0.0043	16
0.9/0.4	M3AA 100 LA	3GAA 108 209-**-E	950/720	68.0/55.0	0.77/0.61	2.5/1.8	3.4/2.7	9.1/5.3	1.2/1.1	1.8/1.8	0.0069	20
1.2/0.5	M3AA 100 LB	3GAA 108 210-**-E	950/710	71.0/57.0	0.71/0.61	3.5/2.1	3.7/2.9	12/6.6	1.3/1.2	2.0/2.0	0.0082	23
17/7.5	M3AA 200MLB	3GAA 208 221-**-C	985/740	88.0/81.5	0.85/0.77	33/17	7.1/6.4	165/97	2.2/2.2	2.5/2.5	0.42	185
20/9	M3AA 200MLC	3GAA 208 222-**-C	985/740	88.5/82.5	0.84/0.74	39/21	7.6/7.0	194/116	2.4/2.6	2.7/2.9	0.48	200
26/12	M3AA 225SMB	3GAA 228 215-**-C	985/740	89.5/84.5	0.85/0.76	49/27	7.4/7.1	252/155	2.2/2.4	2.5/2.7	0.63	225
32/14	M3AA 225SMC	3GAA 228 216-**-C	985/740	90.5/85.5	0.83/0.76	62/31	7.0/7.2	310/180	2.4/2.5	2.4/2.5	0.74	250
43/15	M3AA 250SMB	3GAA 258 208-**-C	990/745	91.0/86.0	0.84/0.75	81/34	7.3/7.4	415/198	2.2/2.7	2.5/2.8	1.41	320
<b>1000/500 r/min = 6 - 12 poles</b>			<b>400 V 50 Hz</b>			<b>Fan drive, Dahlander-connection</b>						
0.40/0.08	M3VA 80 A	3GVA 088 361-**-B	900/460	62.0/30.0	0.78/0.56	1.2/0.7	3.1/1.9	4.26/1.67	1.6/1.6	1.6/1.7	0.0019	9
0.50/0.105	M3VA 80 B	3GVA 088 362-**-B	915/465	66.0/31.0	0.75/0.52	1.45/0.95	3.7/2.0	5.23/2.16	1.9/1.9	2.0/2.0	0.0022	10
0.60/0.12	M3VA 80 C	3GVA 088 363-**-B	920/470	68.0/32.0	0.74/0.50	1.75/1.05	3.8/2.1	6.24/2.45	2.0/2.0	2.0/2.0	0.0025	11
0.5/0.08	M3AA 90 S	3GAA 098 107-**-E	920/440	60.0/31.0	0.74/0.59	1.7/0.63	2.9/1.7	5.2/1.7	1.2/1.4	1.8/2.0	0.0032	13
0.75/0.12	M3AA 90 L	3GAA 098 108-**-E	930/450	64.0/36.0	0.73/0.54	2.4/0.9	3.0/1.8	7.7/2.5	1.3/1.6	1.9/1.9	0.0043	16
0.9/0.16	M3AA 100 LA	3GAA 108 106-**-E	940/470	69.0/45.0	0.73/0.49	2.6/0.96	3.6/2.1	9/3.2	1.3/1.2	2.0/1.8	0.0069	20
1.3/0.2	M3AA 100 LB	3GAA 108 107-**-E	940/460	71.0/52.0	0.76/0.47	3.5/1.2	3.4/2.2	13/4	1.2/1.0	1.8/1.5	0.0082	23

Data for motor size 280 on request.

The bullets in the product code indicate choice of mounting arrangement, voltage and frequency, generation code (see ordering information page).

# General purpose aluminium motors

## Technical data for totally enclosed squirrel cage three phase motors, two-speed

IP 55 – IC 411 – Insulation class F, temperature rise class F

Output kW	Motor type	Product code	Speed r/min	Efficiency %	Power factor cos φ	Current		Torque			Moment of inertia	
						I <sub>N</sub> A	I <sub>s</sub> I <sub>N</sub>	T <sub>N</sub> Nm	T <sub>s</sub> T <sub>N</sub>	T <sub>max</sub> T <sub>N</sub>	J = ¼ GD <sup>2</sup> kgm <sup>2</sup>	Weight kg
<b>3000/1500 r/min = 2/4 poles</b>			<b>400 V 50 Hz</b>			<b>Constant torque, two separate windings</b>						
0.58/0.28	M3VA 80 A	3GVA 089 121-→B	2850/1400	70.0/60.0	0.88/0.78	1.35/0.85	4.4/3.1	1.95/1.92	1.6/1.5	1.9/1.5	0.0008	9
0.70/0.36	M3VA 80 B	3GVA 089 122-→B	2860/1400	74.0/64.0	0.88/0.78	1.55/1.05	5.0/3.4	2.35/2.46	1.8/1.6	2.2/1.8	0.0009	11
0.85/0.42	M3VA 80 C	3GVA 089 123-→B	2890/1410	76.0/66.0	0.87/0.76	1.85/1.25	5.6/3.5	2.82/2.85	1.9/1.7	2.5/1.7	0.0012	12
1.1/0.55	M3AA 90 S	3GAA 098 213-→E	2900/1450	74.0/62.0	0.85/0.64	2.5/2.0	5.1/3.6	3.6/3.6	1.4/1.5	2.3/2.3	0.0019	13
1.5/0.75	M3AA 90 L	3GAA 098 214-→E	2900/1450	77.0/70.0	0.87/0.67	3.3/2.4	5.7/4.1	4.9/4.9	1.5/1.5	2.5/2.3	0.0024	16
2/1	M3AA 100 L	3GAA 108 212-→E	2900/1460	76.0/67.0	0.89/0.66	4.3/3.3	6.2/4.0	6.5/6.5	1.9/1.4	2.8/2.6	0.0041	21
2.6/1.3	M3AA 112 M	3GAA 118 201-→C	2900/1460	80.0/75.0	0.92/0.72	5.1/3.5	6.4/5.0	8.6/8.5	1.6/1.6	2.3/2.3	0.012	32
4.4/2.2	M3AA 132 SB	3GAA 138 201-→C	2925/1450	81.0/74.0	0.86/0.73	9.1/5.9	7.3/4.4	14.4/14.5	2.0/1.3	2.3/2.2	0.016	42
5.6/2.8	M3AA 132 M	3GAA 138 202-→C	2885/1440	82.0/77.0	0.93/0.75	10.6/7	6.7/5.0	18.5/18.6	1.8/1.4	2.1/2.2	0.022	56
12/6	M3AA 160 M	3GAA 168 359-→C	2835/1460	87.5/84.5	0.92/0.80	22/13	7.7/6.0	39/39	2.1/2.3	2.8/2.4	0.054	92
15/7.5	M3AA 160 L	3GAA 168 360-→C	2940/1460	88.5/84.5	0.93/0.78	27/16.5	7.9/6.0	49/49	2.2/2.4	2.9/2.4	0.057	99
18/9	M3AA 180 L	3GAA 188 352-→C	2945/1460	89.0/84.0	0.90/0.77	32/20	7.7/5.2	58/59	2.5/2.3	2.8/2.1	0.108	152
23/12	M3AA 200 MLA	3GAA 208 201-→C	2960/1475	90.0/89.0	0.89/0.85	42/23	7.8/7.4	74/77	1.7/2.2	2.8/2.5	0.28	178
30/16	M3AA 200 MLB	3GAA 208 202-→C	2960/1475	91.0/90.0	0.90/0.87	53/30	8.2/7.3	97/104	1.8/2.2	2.9/2.5	0.34	204
36/18	M3AA 225 SMB	3GAA 228 201-→C	2960/1480	91.5/91.5	0.91/0.76	63/38	8.0/7.2	116/116	2.5/3.8	2.7/2.5	0.26	236
40/20	M3AA 225 SMC	3GAA 228 202-→C	2960/1475	92.0/91.5	0.91/0.79	69/41	8.5/6.5	129/129	2.8/3.3	2.8/2.2	0.29	261
50/25	M3AA 250 SMB	3GAA 258 201-→C	2965/1485	93.0/93.0	0.91/0.76	86/52	8.9/8.5	161/161	2.1/3.5	2.9/2.9	0.57	333
<b>3000/1500 r/min = 2 - 4 poles</b>			<b>400 V 50 Hz</b>			<b>Constant torque, Dahlander-connection</b>						
0.11/0.07	M3VA 56 B	3GVA 050 122-→A	2730/1370	53.0/44.0	0.75/0.58	0.40/0.40	3.4/2.4	0.38/0.48	2.2/2.7	2.2/2.6	0.00018	3.5
0.20/0.15	M3VA 63 A	3GVA 060 121-→A	2730/1400	63.0/54.0	0.70/0.63	0.65/0.65	3.6/3.3	0.70/1.02	2.1/2.1	2.1/2.1	0.00019	4
0.30/0.20	M3VA 63 B	3GVA 060 122-→A	2730/1400	59.0/55.0	0.78/0.63	0.95/0.85	2.8/3.6	1.05/1.36	1.7/2.1	1.8/2.2	0.00026	4.5
0.37/0.25	M3VA 71 A	3GVA 070 121-→B	2700/1390	64.0/57.0	0.89/0.79	0.95/0.80	3.0/2.9	1.31/1.72	1.7/1.9	1.7/1.9	0.00066	5.5
0.48/0.31	M3VA 71 B	3GVA 070 122-→B	2700/1390	68.0/65.0	0.91/0.76	1.1/0.90	3.2/3.4	1.7/2.14	1.7/2.1	1.7/2.1	0.00089	6.5
0.55/0.37	M3VA 71 C	3GVA 070 123-→B	2800/1400	70.0/68.0	0.80/0.65	1.4/1.2	4.6/4.1	1.87/2.52	2.4/2.9	2.4/2.9	0.00110	7
0.63/0.50	M3VA 80 A	3GVA 080 121-→B	2690/1400	66.0/67.0	0.87/0.79	1.6/1.35	3.6/4.2	2.25/3.42	1.8/1.9	1.9/2.1	0.00130	9
0.85/0.65	M3VA 80 B	3GVA 080 122-→B	2725/1405	70.0/70.0	0.88/0.80	2/1.7	4.0/4.4	2.99/4.43	1.9/2.0	1.9/2.2	0.00160	10.5
1.10/0.80	M3VA 80 C	3GVA 080 123-→B	2730/1410	72.0/71.0	0.88/0.79	2.55/2.05	4.2/4.7	3.8/5.38	2.0/2.0	2.1/2.4	0.00200	11
1.3/1	M3AA 90 S	3GAA 098 110-→E	2730/1400	71.0/71.0	0.88/0.80	3.1/2.6	3.9/3.8	4.5/6.8	2.0/1.5	2.2/2.0	0.0032	13
1.9/1.5	M3AA 90 L	3GAA 098 111-→E	2820/1420	74.0/75.0	0.82/0.76	4.4/3.9	5.1/4.4	6.4/10	2.8/2.0	3.0/2.5	0.0043	16
2.5/2.1	M3AA 100 LA	3GAA 108 109-→E	2800/1430	68.0/76.0	0.88/0.81	6.0/5.0	4.8/4.4	8.5/14	2.2/1.6	2.5/2.2	0.0069	20
3.4/2.7	M3AA 100 LB	3GAA 108 110-→E	2810/1430	78.0/80.0	0.88/0.85	7.2/5.9	5.3/5.4	11.5/18	2.2/1.9	2.5/2.5	0.0082	23
4/2.6	M3AA 112 M	3GAA 118 101-→C	2865/1430	82.0/77.0	0.94/0.76	7.6/6.5	6.3/6.2	13.3/17.4	1.8/2.3	2.1/2.6	0.012	32
4.7/3.1	M3AA 132 SB	3GAA 138 101-→C	2820/1420	79.0/77.0	0.93/0.76	9.2/7.7	5.5/5.7	15.9/20.8	1.8/2.2	2.1/2.4	0.016	42
7.2/4.8	M3AA 132 M	3GAA 138 102-→C	2870/1435	84.0/81.0	0.93/0.76	13.3/11.5	7.1/6.2	24/31.9	2.4/2.5	2.6/2.7	0.022	56
9/6.5	M3AA 160 MA	3GAA 168 306-→C	2885/1440	83.0/82.0	0.92/0.74	17.1/15.6	4.6/4.3	40/43	1.3/1.7	1.9/1.9	0.039	73
12.5/9	M3AA 160 M	3GAA 168 307-→C	2890/1440	85.5/85.5	0.93/0.80	22.5/19	5.2/4.6	41/60	1.4/1.8	1.9/1.9	0.054	92
15/10.5	M3AA 160 L	3GAA 168 308-→C	2900/1445	87.0/86.0	0.93/0.77	27/23	5.8/4.9	49/69	1.6/2.1	2.1/2.1	0.057	99
18/12	M3AA 180 M	3GAA 188 301-→C	2940/1455	89.0/89.0	0.88/0.79	33/25	6.8/5.3	59/79	2.1/2.4	2.6/2.2	0.094	132
24/17	M3AA 180 L	3GAA 188 302-→C	2945/1455	90.0/90.0	0.89/0.80	43/34	7.4/5.2	78/111	2.4/2.4	2.8/2.1	0.108	152
32/24	M3AA 200 MLA	3GAA 208 101-→C	2940/1470	89.0/90.5	0.89/0.86	58/45	6.8/5.9	104/156	1.8/2.1	2.4/2.1	0.28	180
39/29	M3AA 200 MLB	3GAA 208 102-→C	2950/1470	90.5/91.0	0.84/0.86	75/53	6.8/7.0	126/188	1.7/2.2	2.6/2.4	0.34	205
42/32	M3AA 225 SMB	3GAA 228 101-→C	2955/1475	92.5/93.0	0.92/0.88	71/57	7.1/6.5	136/207	1.5/1.9	2.5/2.3	0.49	230
50/40	M3AA 225 SMC	3GAA 228 102-→C	2960/1475	92.5/93.0	0.84/0.87	94/71	7.4/7.1	161/259	1.8/2.0	2.8/2.5	0.49	265
68/50	M3AA 250 SMB	3GAA 258 101-→C	2940/1475	93.0/93.5	0.93/0.88	113/87	6.6/6.9	220/324	1.5/2.1	2.4/2.5	0.89	335

# General purpose aluminium motors

## Technical data for totally enclosed squirrel cage three phase motors, two-speed

IP 55 – IC 411 – Insulation class F, temperature rise class F

Output kW	Motor type	Product code	Speed r/min	Efficiency %	Power factor cos φ	Current		Torque			Moment of inertia	
						I <sub>N</sub> A	I <sub>s</sub> I <sub>N</sub>	T <sub>N</sub> Nm	T <sub>s</sub> T <sub>N</sub>	T <sub>max</sub> T <sub>N</sub>	J = ¼ GD <sup>2</sup> kgm <sup>2</sup>	Weight kg
<b>3000/750 r/min = 2/8 poles</b>			<b>400 V 50 Hz</b>			<b>Constant torque, two separate windings</b>						
0.25/0.06	M3VA 71 A	3GVA 079 141-**-B	2760/660	52.0/36.0	0.89/0.70	0.80/0.35	2.9/1.8	0.86/0.86	1.4/1.4	1.8/1.4	0.00066	5.5
0.37/0.09	M3VA 71 B	3GVA 079 142-**-B	2800/660	68.0/41.0	0.80/0.65	1/0.50	2.8/2.0	1.26/1.3	1.2/1.6	1.6/1.6	0.00089	6.5
0.50/0.12	M3VA 80 A	3GVA 089 141-**-B	2730/700	60.0/38.0	0.87/0.58	1.4/0.80	3.2/2.3	1.78/1.64	1.3/2.0	1.6/2.0	0.00130	9
0.66/0.15	M3VA 80 B	3GVA 089 142-**-B	2780/700	65.0/40.0	0.87/0.58	1.65/0.95	3.8/2.5	2.55/2.45	1.4/2.2	1.8/2.2	0.00160	10.5
0.78/0.18	M3VA 80 C	3GVA 089 143-**-B	2800/700	68.0/43.0	0.87/0.57	1.9/1.15	4.0/2.6	2.67/2.46	1.5/2.4	2.2/2.4	0.00200	11
0.75/0.18	M3AA 90 LA	3GAA 098 700-**-E	2875/720	71.2/46.3	0.80/0.51	1.9/1.1	5.7/2.4	2.5/2.4	2.3/1.3	2.7/1.9	0.0043	16
1.3/0.33	M3AA 90 LB	3GAA 098 701-**-E	2780/690	71.0/52.0	0.92/0.62	2.9/1.5	4.5/2.3	4.4/4.5	1.8/1.2	2.0/1.7	0.0043	16
1.8/0.5	M3AA 100 LB	3GAA 108 700-**-E	2860/705	80.0/54.0	0.93/0.64	3.5/2.1	5.3/2.6	6.0/6.7	1.7/1.3	2.2/1.9	0.0082	24
<b>1500/1000 r/min = 4/6 poles</b>			<b>400 V 50 Hz</b>			<b>Constant torque, two separate windings</b>						
0.11/0.08	M3VA 63 B	3GVA 069 232-**-A	1390/860	40.0/25.0	0.60/0.64	0.70/0.70	2.0/1.8	0.75/0.88	1.4/2.4	1.9/2.1	0.00026	4.5
0.30/0.20	M3VA 71 A	3GVA 079 231-**-B	1390/900	57.0/48.0	0.76/0.74	1/0.80	2.8/2.2	2.1/2.1	1.7/1.6	1.9/1.7	0.00066	5.5
0.37/0.22	M3VA 71 B	3GVA 079 232-**-B	1400/910	58.0/49.0	0.70/0.67	1.3/1	3.2/2.4	2.6/2.4	2.1/1.9	2.4/2.1	0.00089	6.5
0.43/0.28	M3VA 80 A	3GVA 089 231-**-B	1380/910	60.0/54.0	0.85/0.81	1.4/1.2	3.1/2.9	2.54/3.02	1.5/1.4	1.5/1.4	0.00190	9
0.58/0.37	M3VA 80 B	3GVA 089 232-**-B	1390/920	63.0/58.0	0.85/0.80	1.6/1.15	3.3/3.2	4/3.85	1.5/1.5	1.6/1.6	0.00220	10
0.70/0.45	M3VA 80 C	3GVA 089 233-**-B	1390/925	65.0/60.0	0.85/0.78	1.85/1.4	3.4/3.4	4.82/4.66	1.6/1.7	1.7/1.8	0.00250	10.5
0.8/0.5	M3AA 90 S	3GAA 098 216-**-E	1430/940	68.0/57.0	0.80/0.66	2.2/2.0	3.9/2.8	5.3/5.0	1.5/1.4	2.1/2.1	0.0032	13
1.2/0.75	M3AA 90 L	3GAA 098 217-**-E	1430/940	73.0/63.0	0.81/0.67	3.0/2.6	4.4/3.1	8.0/7.6	1.7/1.5	2.3/2.1	0.0043	16
1.8/1.1	M3AA 100 LB	3GAA 108 215-**-A	1460/960	77.0/70.0	0.78/0.64	4.4/3.6	5.8/3.9	11/11	2.1/1.6	3.0/2.5	0.0082	23
2.6/1.7	M3AA 112 M	3GAA 118 202-**-C	1445/960	80.0/73.0	0.86/0.76	5.5/4.4	5.9/5.2	17.2/16.9	1.5/1.5	2.2/2.4	0.018	33
3.3/2.2	M3AA 132 S	3GAA 138 223-**-C	1470/980	82.0/76.0	0.82/0.65	7.1/6.4	6.8/4.6	21.4/21.4	1.4/1.2	2.5/2.4	0.038	48
4.5/3	M3AA 132 M	3GAA 138 224-**-C	1470/980	82.0/77.0	0.85/0.70	9.3/8	7.2/5.6	29.2/29.2	1.4/1.5	2.3/2.6	0.048	59
7.5/5.5	M3AA 160 M	3GAA 168 361-**-C	1465/965	85.5/80.5	0.83/0.77	15.5/13	7.1/4.7	49/54	2.1/1.8	2.7/1.9	0.089	93
11.5/8.5	M3AA 160 L	3GAA 168 362-**-C	1465/965	86.5/82.5	0.84/0.76	23/19.5	7.0/4.9	75/84	2.1/1.8	2.8/2.0	0.119	117
138	M3AA 180 M	3GAA 188 353-**-C	1475/975	88.0/82.5	0.82/0.75	26/19	6.5/4.3	84/78	1.9/1.4	2.6/1.8	0.176	131
15/10	M3AA 180 L	3GAA 188 354-**-C	1475/975	88.5/84.0	0.83/0.74	30/23	7.1/4.4	97/98	2.3/1.5	2.7/1.9	0.224	159
18/12	M3AA 200 MLA	3GAA 208 204-**-C	1475/985	88.5/86.0	0.91/0.86	33/24	7.6/7.8	117/116	2.1/2.6	2.5/2.6	0.42	185
22/14.7	M3AA 200 MLB	3GAA 208 205-**-C	1480/985	89.5/86.5	0.89/0.87	40/29	8.2/7.6	142/143	2.4/2.6	2.8/2.5	0.48	200
25/16.7	M3AA 200 MLC	3GAA 208 206-**-C	1475/980	89.0/85.5	0.87/0.88	47/32	7.7/6.7	162/162	2.3/2.3	2.6/2.2	0.48	200
32/21	M3AA 225 SMB	3GAA 228 203-**-C	1480/985	90.0/89.5	0.88/0.86	58/40	8.6/8.0	206/204	2.3/2.4	2.8/2.7	0.63	225
36/24	M3AA 225 SMC	3GAA 228 204-**-C	1480/985	90.5/90.0	0.88/0.87	66/45	8.4/7.4	232/233	2.2/2.2	2.8/2.5	0.74	250
50/32	M3AA 250 SMB	3GAA 258 202-**-C	1475/985	92.5/90.5	0.89/0.80	89/65	7.5/7.1	324/310	2.3/3.1	2.6/2.6	0.89	335

Data for motor size 280 on request.

The bullets in the product code indicate choice of mounting arrangement, voltage and frequency, generation code (see ordering information page).

# General purpose aluminium motors

## Technical data for totally enclosed squirrel cage three phase motors, two-speed

IP 55 – IC 411 – Insulation class F, temperature rise class F

Output kW	Motor type	Product code	Speed r/min	Efficiency %	Power factor cos φ	Current		Torque			Moment of inertia		Weight kg
						I <sub>N</sub> A	I <sub>s</sub> I <sub>N</sub>	T <sub>N</sub> Nm	T <sub>s</sub> T <sub>N</sub>	T <sub>max</sub> T <sub>N</sub>	J = ¼ GD <sup>2</sup> kgm <sup>2</sup>		
<b>1500/750 r/min = 4/8 poles</b>			<b>400 V 50 Hz</b>			<b>Constant torque, two separate windings</b>							
0.28/0.14	M3VA 80 A	3GVA 089 241-→B	1425/700	60.0/50.0	0.77/0.68	0.9/0.6	4.0/3.0	1.88/1.92	1.9/1.9	2.2/2	0.0019	9	
0.38/0.19	M3VA 80 B	3GVA 089 242-→B	1430/705	64.0/52.0	0.77/0.68	1.1/0.8	4.2/3.1	2.55/2.58	2.0/2.0	2.4/2	0.0022	10	
0.46/0.23	M3VA 80 C	3GVA 089 243-→B	1430/710	66.0/55.0	0.78/0.65	1.3/0.95	4.3/3.3	3.1/3.1	2/2.1	2.4/2.2	0.0025	11	
0.55/0.25	M3AA 90 S	3GAA 098 219-→E	1450/700	62.0/51.0	0.78/0.59	1.9/1.2	4.2/2.3	3.6/3.4	1.3/1.4	2.2/2.1	0.0032	13	
0.75/0.37	M3AA 90 L	3GAA 098 220-→E	1450/700	66.0/57.0	0.75/0.57	2.2/1.7	4.1/2.5	4.9/5.0	1.4/1.5	2.4/2.2	0.0043	16	
1.1/0.55	M3AA 100 LA	3GAA 108 217-→E	1460/710	68.0/62.0	0.77/0.61	3.1/2.2	4.2/2.6	7.2/7.4	1.2/1.2	2.3/1.9	0.0069	20	
1.5/0.75	M3AA 100 LB	3GAA 108 218-→E	1440/700	72.0/60.0	0.82/0.60	3.7/2.9	4.6/2.7	9.8/10	1.3/1.2	2.2/1.9	0.0082	23	
1.8/0.9	M3AA 112 M	3GAA 118 203-→C	1470/715	77.0/65.0	0.76/0.66	4.4/3.0	6.5/4.0	11.7/12	1.2/1.6	2.2/2.4	0.018	32	
2.5/1.3	M3AA 132 S	3GAA 138 225-→C	1470/730	80.0/69.0	0.79/0.58	5.7/4.7	6.7/4.4	16.2/17	1.6/1.4	2.6/2.7	0.038	48	
3.3/1.7	M3AA 132 M	3GAA 138 226-→C	1470/725	81.0/71.0	0.83/0.67	7.1/5.2	8.0/4.8	21.4/22.4	1.8/1.8	2.7/2.2	0.048	59	
5.5/2.7	M3AA 160 M	3GAA 168 363-→C	1465/730	85.0/71.0	0.83/0.57	11.5/9.6	5.6/4.0	36/35	1.7/2.0	2.2/2.3	0.089	92	
9/4.5	M3AA 160 L	3GAA 168 364-→C	1465/730	86.5/73.5	0.83/0.56	18/16	7.0/4.1	59/59	2.1/2.1	2.7/2.5	0.119	117	
14/7	M3AA 180 L	3GAA 188 356-→C	1475/735	88.0/76.0	0.83/0.56	28/24	7.7/4.2	91/91	2.6/2.3	2.9/2.3	0.225	159	
18.5/9.4	M3AA 200 MLA	3GAA 208 207-→C	1475/730	89.5/82.5	0.85/0.65	35/26	7.3/4.3	120/123	2.2/1.9	2.5/1.8	0.28	180	
22/11	M3AA 200 MLB	3GAA 208 208-→C	1480/735	90.5/83.0	0.84/0.60	42/32	8.4/4.7	142/143	2.6/2.4	2.9/2.2	0.34	205	
28/14	M3AA 225 SMB	3GAA 228 205-→C	1480/735	90.0/85.5	0.85/0.61	53/39	7.7/4.9	181/182	2.1/2.4	2.7/2.2	0.41	230	
34/17	M3AA 225 SMC	3GAA 228 206-→C	1480/735	92.0/87.0	0.86/0.66	63/43	7.9/4.8	219/221	2.2/2.2	2.7/2.0	0.49	265	
50/25	M3AA 250 SMB	3GAA 258 203-→C	1480/740	92.5/88.0	0.87/0.60	90/68	8.6/6.0	323/323	2.6/3.5	3.0/2.9	0.89	335	
<b>1500/750 r/min = 4 - 8 poles</b>			<b>400 V 50 Hz</b>			<b>Constant torque, Dahlander-connection</b>							
0.11/0.06	M3VA 63 B	3GVA 060 242-→A	1390/660	54.0/33.0	0.60/0.54	0.50/0.50	3.0/1.7	0.75/0.87	2.5/2.5	2.6/2.6	0.00026	4.5	
0.18/0.11	M3VA 71 A	3GVA 070 241-→B	1350/680	54.0/37.0	0.80/0.70	0.60/0.60	3.1/2.1	1.27/1.54	1.9/2.0	2.0/1.9	0.00066	5.5	
0.30/0.15	M3VA 71 B	3GVA 070 242-→B	1350/680	60.0/47.0	0.80/0.51	0.90/0.90	2.9/2.1	2.12/2.11	1.6/2.4	1.6/2.2	0.00089	6.5	
0.45/0.25	M3VA 80 A	3GVA 080 241-→B	1380/700	65.0/48.0	0.87/0.58	1.15/1.3	3.5/2.7	3.12/3.42	1.7/2.1	1.7/2.1	0.00190	9	
0.63/0.33	M3VA 80 B	3GVA 080 242-→B	1350/680	63.0/48.0	0.88/0.64	1.65/1.55	3.5/2.8	4.46/4.64	1.7/2.2	1.7/2.2	0.00220	10	
0.75/0.37	M3VA 80 C	3GVA 080 243-→B	1335/690	68.0/49.0	0.89/0.62	1.8/1.76	3.9/2.9	5.37/5.12	1.9/2.5	1.9/2.5	0.00250	10.5	
0.7/0.37	M3AA 90 S	3GAA 098 113-→E	1420/700	72.0/50.0	0.80/0.57	1.8/1.9	4.4/2.3	4.7/5.1	1.6/1.6	2.3/2.2	0.0032	13	
1.1/0.55	M3AA 90 L	3GAA 098 114-→E	1390/685	70.0/55.0	0.84/0.58	2.6/2.6	4.1/2.3	7.4/7.5	1.4/1.5	2.0/2.1	0.0043	16	
1.5/0.75	M3AA 100 LA	3GAA 108 112-→E	1440/710	76.0/62.0	0.85/0.57	3.4/3.2	4.6/2.8	10/10	1.4/1.5	2.2/2.2	0.0069	20	
2/0.95	M3AA 100 LB	3GAA 108 113-→E	1440/710	78.0/64.0	0.86/0.55	4.4/4.0	4.8/2.9	13/12	1.4/1.6	2.2/2.3	0.0082	23	
2.5/1.5	M3AA 112 M	3GAA 118 103-→C	1410/705	78.0/67.0	0.90/0.66	5.1/4.9	5.5/4.1	16.9/20.3	1.4/1.5	2.1/2.4	0.018	32	
3.8/1.9	M3AA 132 S	3GAA 138 125-→C	1450/730	82.0/70.0	0.86/0.52	7.7/7.6	5.6/3.7	25/24.9	1.4/1.3	2.1/2.7	0.038	48	
5/2.5	M3AA 132 M	3GAA 138 126-→C	1455/730	85.0/73.0	0.88/0.52	9.6/9.6	6.9/4.8	32.8/32.7	1.7/2.0	2.4/2.8	0.048	59	
8/4.5	M3AA 160 M	3GAA 168 309-→C	1440/730	84.5/79.5	0.86/0.60	16/13.5	4.5/3.4	53/59	1.3/1.4	1.8/1.9	0.089	92	
12/7	M3AA 160 L	3GAA 168 310-→C	1445/730	86.5/81.0	0.87/0.59	23/21	5.0/3.5	79/92	1.5/1.4	1.9/1.9	0.119	117	
16/8	M3AA 180 L	3GAA 188 304-→C	1460/730	88.0/78.5	0.86/0.53	31/28	1.9/3.4	105/104	1.4/1.6	1.9/2.1	0.224	159	
22/13	M3AA 200 MLA	3GAA 208 107-→C	1475/735	87.5/86.0	0.81/0.69	45/32	6.5/5.9	142/169	2.0/2.5	2.6/2.7	0.36	165	
25/15	M3AA 200 MLB	3GAA 208 108-→C	1475/735	89.0/86.0	0.86/0.67	47/38	7.6/6.0	162/195	2.2/2.6	2.7/2.7	0.42	185	
29/17	M3AA 200 MLC	3GAA 208 109-→C	1475/735	90.0/88.0	0.91/0.75	52/38	7.2/6.1	188/221	2.2/2.6	2.4/2.4	0.48	200	
35/21	M3AA 225 SMB	3GAA 228 105-→C	1475/735	90.0/89.0	0.90/0.74	63/47	6.7/5.8	227/273	1.7/2.1	2.2/2.3	0.63	225	
42/25	M3AA 225 SMC	3GAA 228 106-→C	1475/735	91.0/89.5	0.91/0.75	74/54	6.8/5.9	272/325	1.8/2.1	2.2/2.2	0.74	250	
55/33	M3AA 250 SMB	3GAA 258 103-→C	1480/740	92.0/90.5	0.90/0.75	97/71	7.3/6.4	355/426	2.1/2.5	2.5/2.5	1.5	320	
<b>1000/750 r/min = 6/8 poles</b>			<b>400 V 50 Hz</b>			<b>Constant torque, two separate windings</b>							
1.6/0.8	M3AA 112 M	3GAA 118 207-→C	965/725	72.9/60.0	0.70/0.64	4.5/3.0	5.6/4.4	15.8/10.6	2.3/2.3	2.6/2.4	0.015	35	
2.3/1.3	M3AA 132 S	3GAA 138 213-→C	975/730	77.2/63.5	0.72/0.64	6.8/4.6	6.4/4.2	25.4/17	1.6/1.5	2.8/2.3	0.04	48	
3.5/1.6	M3AA 132 M	3GAA 138 214-→C	975/730	78.8/65.8	0.72/0.66	9.0/5.2	7.1/5.1	34.2/20.9	2.0/1.9	2.9/2.4	0.041	48	
16/12	M3AA 200 MLB	3GAA 208 219-→C	985/740	86.5/82.5	0.85/0.73	31/29	7.0/6.3	155/155	2.1/2.4	2.4/2.6	0.42	185	
18/13.5	M3AA 200 MLC	3GAA 208 220-→C	985/740	87.5/83.5	0.83/0.72	36/32	7.9/6.6	174/174	2.5/2.6	2.8/2.8	0.48	200	
23/17	M3AA 225 SMB	3GAA 228 213-→C	985/740	89.0/85.5	0.84/0.78	46/37	7.9/6.3	222/220	2.3/2.2	2.7/2.3	0.63	225	
28/20	M3AA 225 SMC	3GAA 228 214-→C	985/740	89.0/86.5	0.86/0.77	57/43	7.1/6.5	272/259	2.0/2.3	2.4/2.4	0.74	250	
37/27	M3AA 250 SMB	3GAA 258 207-→C	990/740	90.0/87.5	0.83/0.75	71/59	7.8/6.7	357/348	2.3/2.5	2.7/2.5	1.41	320	

# General purpose aluminium motors - Variant codes

Code	Variant	Motor size			M2AA	M2AA	M2AA	M3AA	M3AA	M3AA	M3AA
		56-63	71-80	90-100	112-132	160-200	225-250	112-132	160-180	200-250	280
<b>Balancing</b>											
052	Balancing to grade R (IEC 60034-14).	P	P	P	P	P	P	P	P	P	P
417	Balancing to grade S (IEC 60034-14).	NA	NA	NA	R	R	R	R	R	R	R
423	Balancing without key.	P	P	P	R	R	R	R	R	R	R
424	Full key balancing.	P	P	P	P	P	P	P	P	P	P
<b>Bearings and lubrication</b>											
036	Transport lock for bearings.	NA	NA	M	M	M	M	M	M	M	M
037	Roller bearing at D-end. Transport lock included.	NA	NA	M	NA	M	M	NA	M	M	M
039	Cold resistant grease. For ambient temperatures -40 - +100° C.	M	M	M	M	M	M	M	M	M	M
040	Heat resistant grease. For bearing temperatures -40 - +160° C. Mandatory for ambient temperatures >50° C.	M	M	M	S	S	S	S	S	S	S
041	Bearings regreasable via grease nipples.	NA	NA	M	M	M	S	M	M	S	S
042	Locked drive-end. Standard for sizes 90-132, flanged versions.	NA	M	S	M	S	S	M	S	S	S
043	SPM nipples.	NA	NA	R	M	M	M	M	M	M	M
057	2RS bearings at both ends. Grease for bearing temperatures -20 - +110° C.	M	M	M	M	R	R	M	M	M	M
058	Angular contact ball bearing at D-end, shaft force away from bearing. Transport lock included.	NA	NA	M	M	R	R	M	M	M	M
059	Angular contact ball bearing at N-end, shaft force towards bearing. Transport lock included.	NA	NA	M	M	R	R	M	M	M	M
107	Bearing mounted PT100 resistance elements.	NA	NA	NA	NA	NA	NA	NA	R	R	R
188	63-series bearings.	NA	NA	M	M	S	S	M	S	S	S
<b>Branch standard designs</b>											
071	Cooling tower duty. Only motors with shaft extensions downwards.	NA	NA	NA	P	P	P	P	P	P	P
079	Silumin-alloy rotor cage.	NA	P	P	R	R	R	R	R	R	R
142	"Manilla" winding connection. (440 VΔ series, 220 VΔ parallel, 60Hz) Single speed motors only.	NA	NA	P	P	P	P	P	P	P	P
170	Smoke venting specification 200 °C, 2 h (CTICM).	NA	NA	P	P	NA	NA	P	P	P	NA
171	Smoke venting specification 300 °C, 0.5 h (CTICM).	NA	NA	P	P	NA	NA	P	P	P	NA
178	Stainless steel/acid proof bolts.	M	M	M	M	M	M	M	M	M	M
199	Extreme heavy duty design. Type designation M2AP or M3AP.	NA	NA	NA	M	NA	NA	M	M	M	M
209	Non-standard voltage or frequency (special winding).	P	P	P	P	P	P	P	P	P	P
217	Cast iron D-end shield (on aluminium motor).	NA	NA	M	R	R	R	R	R	R	R
416	High speed design.	NA	NA	NA	R	R	R	R	R	R	R
425	Corrosion protected stator and rotor core.	P	P	P	P	R	R	P	P	P	P
<b>Cooling system</b>											
053	Metal fan cover. The dimension L1 and L2 respectively is increased by 7.5 mm for the frame size 112 and 5.5 mm for the frame size 132.	S	S	S	M	S	S	M	S	S	S

<sup>1)</sup> Certain variant codes cannot be used simultaneously.

S = Included as standard.  
M = On modification of a stocked motor,  
or on new manufacture,  
the number per order may be limited.

P = New manufacture only.  
R = On request.  
NA = Not applicable.

Code	Variant	Motor size			M2AA	M2AA	M2AA	M3AA	M3AA	M3AA	M3AA
		56-63	71-80	90-100	112-132	160-200	225-250	112-132	160-180	200-250	280
068	Aluminium fan. Mandatory for ambient temperatures: For sizes 71-100, $\geq 80$ °C; sizes 112-132, $> 50$ °C; sizes 160-250, $> 80$ °C	NA	M	M	M	M	M	M	M	M	M
075	Cooling method IC418 (without fan).	P	P	P	R	R	R	R	R	R	R
183	Separate motor cooling (fan axial, N-end).	NA	M	R	NA	R	R	NA	M	M	M
189	Separate motor cooling, IP44, 400V, 50Hz (fan axial, N-end)	NA	NA	NA	M	M	M	M	M	M	M
793	Fan for reduced noise level (2-p fan).	NA	NA	NA	R	R	R	R	R	R	R
794	Fan for reduced noise level (4-p fan).	NA	NA	NA	R	R	R	R	R	R	R
<b>Dimension drawing</b>											
141	Binding dimension drawing	M	M	M	M	M	M	M	M	M	M
<b>Drain holes</b>											
065	Plugged drain holes.	M	M	M	M	M	M	M	M	M	M
066	Modified drain hole position. IP 54 for sizes 63-100. Specify IM designation.	M	M	M	M	M	M	M	M	M	M
076	Drain holes with plugs. Holes are sealed with a felt plug. Corrosion protected rotor. IP 55. IM designation must be stated.	S	S	NA	NA	NA	NA	NA	NA	NA	NA
<b>Earthing bolt</b>											
067	External earthing bolt. Earthing screw for connection of external protective earth.	M	M	M	M	M	M	M	M	M	M
<b>Hazardous environments</b>											
See catalogue 'Motors for Hazardous Environments' for details.											
<b>Heating elements</b>											
	Motor size	Element capacity									
	56-71	8 W									
	80-160	25 W									
	180-280	50 W									
450	Heating element 100-120 V.	M	M	M	M	M	M	M	M	M	M
451	Heating element 200-240 V.	M	M	M	M	M	M	M	M	M	M
<b>Insulation systems</b>											
014	Winding insulation class H.	P	P	P	P	P	P	P	P	P	P
405	Special winding insulation for frequency converter supply rated voltage $>500$ V.	NA	NA	R	P	R	R	P	P	P	P
406	Winding for supply $> 690 \geq 1000$ V.	NA	NA	NA	NA	NA	NA	R	R	P	P
<b>Marine Motors</b>											
See catalogue "Marine Motors" for details.											
<b>Mounting arrangements</b>											
NOTE: Multiple flange sizes available using two-piece flange system, see page 48.											
007	IM 3001 flange mounted, IEC flange, from IM 1001 (B5 from B3). Large flange with clearance holes.	NA	M	M	NA	R	M	NA	NA	M	M
008	IM 2101 foot/flange mounted, IEC flange, from IM 1001 (B34 from B3). Small flange with tapped holes. Frame size 180 not available.	NA	M	M	M	R	NA	M	R	NA	NA
009	IM 2001 foot/flange mounted, IEC flange, from IM 1001 (B35 from B3). Large flange with clearance holes.	M	M	M	M	M	M	M	M	M	M

<sup>1)</sup> Certain variant codes cannot be used simultaneously.

S = Included as standard.

M = On modification of a stocked motor,  
or on new manufacture,  
the number per order may be limited.

P = New manufacture only.

R = On request.  
NA = Not applicable.

Code	Variant	Motor size			M2AA	M2AA	M2AA	M3AA	M3AA	M3AA	M3AA
		56-63	71-80	90-100	112-132	160-200	225-250	112-132	160-180	200-250	280
047	IM 3601 flange mounted, IEC flange, from IM 3001 (B14 from B5), flange mounted motor with large flange. Small flange with tapped holes. Frame size 180 not available.	M	M	M	M	R	NA	M	R	NA	NA
048	IM 3001 flange mounted, IEC flange, from IM 3601 (B5 from B14), flange mounted motor with small flange. Large flange with clearance holes.	M	M	M	M	NA	NA	M	NA	NA	NA
078	(IM 3601) Flange mounted, DIN C-flange. Small flange with tapped holes. Larger flange than standard version.	NA	P	NA	NA	NA	NA	NA	NA	NA	NA
080	(IM 3001) Flange mounted, DIN A-flange. Large flange with clearance holes. Larger flange than standard version.	NA	P	NA	NA	NA	NA	NA	NA	NA	NA
090	(IM 2101) foot/flange mounted, DIN C-flange, from IM 1001 (B34 from B3). Small flange with tapped holes. Larger flange than standard version.	NA	P	NA	NA	NA	NA	NA	NA	NA	NA
091	(IM 2001) foot/flange mounted, DIN A-flange, from IM 1001 (B35 from B3). Large flange with clearance holes. Larger flange than standard version.	NA	P	NA	NA	NA	NA	NA	NA	NA	NA
200	Flange ring holder.	NA	P	M	R	NA	NA	R	R	R	R
218	Flange ring FT 85 (NA for frame size 100).	NA	P	M	NA	NA	NA	NA	NA	NA	NA
219	Flange ring FT 100 (NA for frame size 100).	NA	P	M	NA	NA	NA	NA	NA	NA	NA
220	Flange ring FF 100 (NA for frame size 100).	NA	P	M	NA	NA	NA	NA	NA	NA	NA
223	Flange ring FF 115 (NA for frame size 100).	NA	P	M	NA	NA	NA	NA	NA	NA	NA
224	Flange ring FT 115 (NA for frame size 100).	NA	P	M	NA	NA	NA	NA	NA	NA	NA
226	Flange ring FF 130.	NA	P	M	NA	NA	NA	NA	NA	NA	NA
227	Flange ring FT 130.	NA	P	M	NA	NA	NA	NA	NA	NA	NA
233	Flange ring FF 165.	NA	P	M	NA	NA	NA	NA	NA	NA	NA
234	Flange ring FT 165.	NA	P	M	NA	NA	NA	NA	NA	NA	NA
243	Flange ring FF 215 (NA for frame size 90).	NA	NA	M	NA	NA	NA	NA	NA	NA	NA
244	Flange ring FT 215 (NA for frame size 90).	NA	NA	M	NA	NA	NA	NA	NA	NA	NA
<b>Painting</b>											
114	Special paint colour, standard grade.	M	M	M	M	M	M	M	M	M	M
179	Special paint specification.	NA	NA	R	R	R	R	R	R	R	R
<b>Protection</b>											
005	Protective roof, vertical motor, shaft down. Vertically mounted motors with shaft extension downwards. See also the Accessories section for further information.	M	M	M	M	M	M	M	M	M	M
072	Radial seal at D-end.	P	P	M	R	R	R	R	R	R	R
073	Sealed against oil at D-end.	P	P	NA	NA	NA	NA	NA	NA	NA	NA
158	Degree of protection IP65 or IP65X. Dust proof version.	P	P	P	M	M	M	M	M	M	M
211	Weather protected, IP xx W	NA	NA	P	NA	NA	NA	NA	NA	NA	NA
403	Degree of protection IP 56. Water from waves which splash over must not enter in serious quantities.	P	P	P	M	M	M	M	M	M	M
784	Gamma-seal at D-end.	NA	NA	NA	R	R	R	R	R	R	R
<b>Rating and instruction plates</b>											
002	Restamping voltage, frequency, and output. Continuous duty. All data to be specified in the order.	M	M	M	M	M	M	M	M	M	M
003	Individual serial number.	P	P	M	M	M	M	M	M	M	M
004	Additional text on std rating plate (max 12 digits on free text line).	NA	NA	NA	M	M	M	M	M	M	M

<sup>1)</sup> Certain variant codes cannot be used simultaneously.

S = Included as standard.  
M = On modification of a stocked motor, or on new manufacture, the number per order may be limited.

P = New manufacture only.  
R = On request.  
NA = Not applicable



Code	Variant	Motor size			M2AA	M2AA	M2AA	M3AA	M3AA	M3AA	M3AA
		56-63	71-80	90-100	112-132	160-200	225-250	112-132	160-180	200-250	280
013	Restamping to output for class F temperature rise. Applies to variants with temperature rise to class B as standard.	M	M	M	R	R	R	R	R	R	R
095	Restamping of output. Maintained voltage and frequency. Intermittent duty. All data to be specified in order.	M	M	M	M	M	M	M	M	M	M
098	Stainless rating plate.	M	M	M	M	R	R	M	M	M	M
138	Mounting of additional identification plate, aluminium.	M	M	M	M	M	M	M	M	M	M
139	Additional identification plate delivered loose.	M	M	M	M	M	M	M	M	M	M
160	Additional rating plate affixed.	M	M	M	R	R	R	R	R	R	R
161	Additional rating plate delivered loose.	M	M	M	M	M	M	M	M	M	M
163	Additional frequency converter rating plate fixed to stator. Rating data according to quotation.	NA	NA	NA	M	M	M	M	M	M	M
198	Aluminium rating plate.	S	S	S	R	S	S	R	S	S	S
<b>Shaft and rotor</b>											
069	Two shaft extensions as per basic catalogue. Standard shaft material.	P	P	P	P	R	R	P	P	P	P
070	One or two special shaft extensions, standard shaft material.	P	P	P	R	R	R	R	R	R	R
165	Shaft extension with open key-way.	P	P	P	P	NA	NA	P	P	P	P
410	Stainless/acid-proof steel shaft, standard or non-standard design. One or two shaft extensions.	P	P	P	R	R	R	R	R	R	R
<b>Standards and regulations</b>											
010	Fulfilling CSA Safety Certificate.	P	P	P	M	R	R	M	M	M	M
011	Fulfilling CSA. Energy efficiency verification (010 included). For frame sizes 90-100 own product code, contact ABB.	NA	NA	NA	NA	NA	NA	M	M	M	M
029	Fulfilling Underwriters Laboratory (UL) requirements.	P	P	P	NA	NA	NA	NA	NA	NA	NA
408	Energy efficient design, according to IEEE, Std 112	NA	NA	R	NA	NA	NA	M	M	M	NA
770	Motor designed to comply with IEC 60034-1 standard but with S.F. = 1.2 (service factor).	NA	NA	NA	NA	NA	NA	R	R	R	R
778	Gost R Export/Import Certificate (Russia)	R	R	NA	M	M	M	M	M	M	M
779	SASO Export/Import Certificate (Saudi Arabia)	R	R	NA	M	M	M	M	M	M	M
780	PCBC Export/Import Certificate (Poland)	R	R	NA	M	M	M	M	M	M	M
<b>Stator winding temperature sensors</b>											
121	Bimetal detectors, break type (NCC), (3 in series), 130°C, in stator winding. Two-speed motors for only new manufacture.	M	M	M	M	M	M	M	M	M	M
122	Bimetal detectors, break type (NCC), (3 in series), 150°C, in stator winding. Two-speed motors for only new manufacture.	M	M	M	M	M	M	M	M	M	M
123	Bimetal detectors, break type (NCC), (3 in series), 170°C, in stator winding. Two-speed motors only for new manufacture.	M	M	M	M	M	M	M	M	M	M
124	Bimetal detectors, break type (NCC), (3 in series), 140°C, in stator winding. Two-speed motors for only new manufacture.	M	M	NA	M	M	M	M	M	M	M
125	Bimetal detectors, break type (NCC), (2 x 3 in series), 150°C, in stator winding. Two-speed motors only for new manufacture.	M	M	M	M	M	M	M	M	M	M
127	Bimetal detectors, break type (NCC), (3 in series, 130°C & 3 in series, 150°C), in stator winding. Two-speed motors only for new manufacture.	M	M	M	M	M	M	M	M	M	M
321	Bimetal detectors, closing type (NO), (3 in parallel), 130°C, in stator winding.	NA	NA	P	R	NA	NA	R	R	R	R

<sup>1)</sup> Certain variant codes cannot be used simultaneously.

S = Included as standard.  
M = On modification of a stocked motor, or on new manufacture, the number per order may be limited.

P = New manufacture only.  
R = On request.  
NA = Not applicable.

Code	Variant	Motor size			M2AA	M2AA	M2AA	M3AA	M3AA	M3AA	M3AA
		56-63	71-80	90-100	112-132	160-200	225-250	112-132	160-180	200-250	280
1)											
322	Bimetal detectors, closing type (NO), (3 in parallel), 150°C, in stator winding.	NA	NA	P	R	R	R	R	R	R	R
323	Bimetal detectors, closing type (NO), (3 in parallel), 170°C, in stator winding.	NA	NA	P	R	R	R	R	R	R	R
325	Bimetal detectors, closing type (NO), (2x3 in parallel), 150°C, in stator winding.	NA	NA	P	R	R	R	R	R	R	R
327	Bimetal detectors, closing type (NO), (3 in parallel, 130°C, & 3 in parallel, 150°C), in stator winding.	NA	NA	P	R	R	R	R	R	R	R
435	PTC - thermistors, (3 in series), 130°C, 3 in stator winding. Two-speed motors only for new manufacture.	M	M	M	M	M	M	M	M	M	M
436	PTC thermistors, 150°C, 3 in series. Motor sizes 160-180 as modification. Two-speed motors only for new manufacture.	M	M	M	M	M	S	M	M	S	S
437	PTC - thermistors, (3 in series), 170°C, in stator winding. Two-speed motors only for new manufacture.	M	M	M	M	M	M	M	M	M	M
439	PTC - thermistors, (2x3 in series), 150°C, in stator winding. Two-speed motors only for new manufacture.	M	M	M	M	M	M	M	M	M	M
440	PTC - thermistors, (3 in series, 110 °C, & 3 in series, 130°C), in stator winding. Two-speed motors only for new manufacture.	M	M	M	R	R	R	R	R	R	R
441	PTC - thermistors, (3 in series, 130 °C, & 3 in series, 150°C), in stator winding. Two-speed motors only for new manufacture.	M	M	M	M	M	M	M	M	M	M
442	PTC - thermistors, (3 in series, 150 °C & 3 in series, 170°C), in stator winding. Two-speed motors only for new manufacture.	M	M	R	M	M	M	M	M	M	M
445	PT100 (1 per phase) in stator winding. Measurement current max. 10 mA. Temperature: 0 10 20 50 100 150 °C Resistance: 100 103.9 107.7 119.3 128.5 158 Ohm Monitoring unit, more information from ABB.	NA	NA	R	M	M	M	M	M	M	M
446	PT100 (2 per phase) in stator winding. Measurement current max. 10 mA. Temperature: 0 10 20 50 100 150 °C Resistance: 100 103.9 107.7 119.3 128.5 158 Ohm Monitoring unit, more information from ABB.	NA	NA	R	NA	M	M	NA	M	M	M
<b>Terminal box</b>											
015	Motor supplied in D-connection. Single speed motors only.	M	M	M	M	M	M	M	M	M	M
017	Motor supplied in Y-connection. Single speed motors only.	M	M	M	M	M	M	M	M	M	M
018	D connection in terminal box (reconnection from Y.) Single phase Steinmetz.	NA	NA	NA	NA	NA	NA	NA	NA	NA	NA
019	Larger than standard terminal box. Standard for frame size 280, and for sizes 200-250 by voltage code S.	NA	NA	NA	M	M	M	M	M	M	NA
021	Terminal box on left-hand side, seen from D-end.	NA	M	M	NA	NA	R	NA	NA	P	P
112	Mounting of plug-in contact.	NA	NA	R	R	NA	NA	R	NA	NA	NA
180	Terminal box on right-hand side, seen from D-end.	NA	M	M	NA	NA	R	NA	NA	P	P
136	Extended cable connection, standard terminal box. 2 m long connection cable.	P	P	R	R	R	R	R	R	R	R
137	Extended cable connection, low terminal box, 'flying leads'.	NA	NA	P	NA	NA	NA	NA	NA	NA	NA
187	Cable glands of non-standard design.	NA	NA	NA	R	R	R	R	R	R	R
230	Standard cable glands.	M	M	M	M	M	M	M	M	M	M
402	Terminal box adapted for Al cables.	NA	NA	NA	NA	NA	NA	NA	NA	P	P
418	Separate terminal box for temperature detectors.	NA	NA	R	M	M	M	M	M	M	M

1) Certain variant codes cannot be used simultaneously.

S = Included as standard.  
M = On modification of a stocked motor, or on new manufacture, the number per order may be limited.

P = New manufacture only.  
R = On request.  
NA = Not applicable.

Code	Variant	Motor size			M2AA	M2AA	M2AA	M3AA	M3AA	M3AA	M3AA
		56-63	71-80	90-100	112-132	160-200	225-250	112-132	160-180	200-250	280
1)											
467	Lower than standard terminal box and rubber extended cable. Terminal box without screw terminals and extended rubber connection cable, 2 m.	NA	NA	NA	M	R	R	M	M	M	M
731	Two standard cable glands.	NA	M	M	M	M	M	M	M	M	M
<b>Testing</b>											
140	Test confirmation.	M	M	M	M	M	M	M	M	M	M
145	Type test report from test of identical motor. 400 V 50 Hz.	M	M	M	M	M	M	M	M	M	M
146	Type test with report for motor from specific delivery batch.	P	P	P	M	M	M	M	M	M	M
147	Type test report with motor from specific delivery batch, customer witnessed.	P	P	P	M	M	M	M	M	M	M
148	Routine test report.	P	P	M	M	M	M	M	M	M	M
149	Test according to separate test specification.	NA	NA	R	R	R	R	R	R	R	R
153	Reduced test for classification society.	P	P	P	M	M	M	M	M	M	M
221	Type test and multi-point load test with report for motor from specific delivery batch.	R	R	P	M	M	M	M	M	M	M
222	Torque/speed curve, type test and multi-point load test with report from specific delivery batch.	R	R	P	M	M	M	M	M	M	M
760	Vibration level test.	P	P	R	M	M	M	M	M	M	M
762	Noise level test.	P	P	R	M	M	M	M	M	M	M
764	Complete test with ABB frequency converter.	NA	NA	R	R	R	R	R	R	R	R
<b>Variable speed drives</b>											
<i>See also the Accessories section for further information.</i>											
<i>For long cables, see code 405 "Insulation systems".</i>											
<b>Separate motor cooling</b>											
183	Separate motor cooling (fan axial, N-end).	NA	P	R	NA	R	R	NA	M	M	M
189	Separate motor cooling, IP44, 400V, 50Hz (fan axial, N-end).	NA	NA	NA	M	M	M	M	M	M	M
<b>Mounting of tachometer; tachometer not included</b>											
182	Pulse sensor mounted as specified.	NA	NA	R	R	NA	NA	R	R	R	R
470	Prepared for hollow shaft pulse tachometer. (Leine & Linde equivalent).	R	R	R	P	R	R	P	M	M	M
570	Prepared for hollow shaft pulse tachometer (L&L 562).	NA	NA	R	P	M	M	P	M	M	M
<b>Mounting of tachometer; tachometer included</b>											
472	1024 pulse tachometer, (Leine & Linde equivalent). Hollow shaft version.	R	R	R	P	R	R	P	M	M	M
473	2048 pulse tachometer. (Leine & Linde equivalent). Hollow shaft version.	R	R	R	P	R	R	P	M	M	M
572	1024 pulse tachometer (L&L 562).	NA	NA	R	P	M	M	P	M	M	M
573	2048 pulse tachometer (L&L 562).	NA	NA	R	P	M	M	P	M	M	M
<b>Separate motor cooling &amp; prepared for tachometer; tachometer not included</b>											
474	Separate motor cooling and prepared for hollow shaft pulse tachometer. (Leine & Linde equivalent).	NA	NA	R	P	R	R	P	M	M	M
<b>Separate motor cooling &amp; tachometer; tachometer included</b>											
476	Separate motor cooling (fan axial, N-end) and 1024 pulse tachometer. (Leine & Linde equivalent).	NA	NA	R	P	R	R	P	M	M	M
477	Separate motor cooling (fan axial, N-end) and 2048 pulse tachometer. (Leine & Linde equivalent).	NA	NA	R	P	R	R	P	M	M	M
574	Separate motor cooling (fan axial, N-end) and prepared for hollow shaft tachometer (L&L 562).	NA	NA	R	NA	R	R	NA	M	M	M
576	Separate motor cooling (fan axial, N-end) and 1024 pulse tachometer (L&L 562).	NA	NA	R	NA	R	R	NA	M	M	M

1) Certain variant codes cannot be used simultaneously.

S = Included as standard.  
M = On modification of a stocked motor, or on new manufacture, the number per order may be limited.  
P = New manufacture only.

R = On request.  
NA = Not applicable.

Code	Variant	Motor size			M2AA	M2AA	M2AA	M3AA	M3AA	M3AA	M3AA
		56-63	71-80	90-100	112-132	160-200	225-250	112-132	160-180	200-250	280
577	Separate motor cooling (fan axial, N-end) and 2048 pulse tacho (L&L 562).	NA	NA	R	NA	R	R	NA	M	M	M
578	Separate motor cooling, IP44, 400V, 50Hz (fan axial, N-end) and prepared for hollow shaft tacho (L&L 562).	NA	NA	NA	P	M	M	P	M	M	M
580	Separate motor cooling, IP44, 400V, 50Hz (fan axial, N-end) and 1024 pulse tacho (L&L 562).	NA	NA	NA	P	M	M	P	M	M	M
581	Separate motor cooling, IP44, 400V, 50Hz (fan axial, N-end) and 2048 pulse tacho (L&L 562).	NA	NA	NA	P	M	M	P	M	M	M
<b>Y/D starting</b>											
117	Terminals for Y/Δ start at both speeds (two speed motors with separate windings).	NA	NA	P	NA	NA	NA	NA	P	P	NA
118	Terminals for Y/Δ start at high speed (two speed motors with separate windings).	NA	NA	NA	P	NA	NA	P	NA	NA	NA

<sup>1)</sup> Certain variant codes cannot be used simultaneously.

S = Included as standard.

M = On modification of a stocked motor, or on new manufacture, the number per order may be limited.

P = New manufacture only.

R = On request.

NA = Not applicable.

# General purpose aluminium motors

# Sizes 56-100

## Dimension drawings

Foot-mounted motor;  
IM B3 (IM 1001), IM 1002

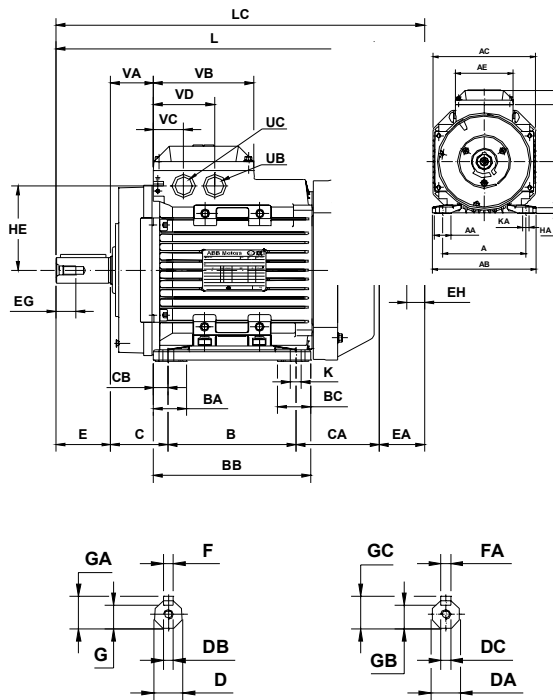

Flange-mounted motor, large flange;  
IM B5 (IM 3001), IM 3002

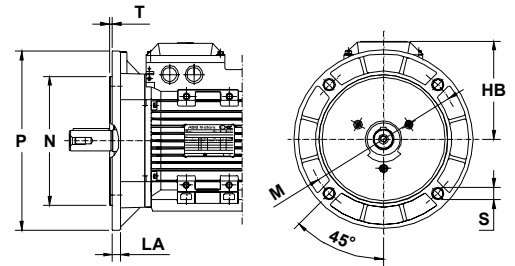

Flange-mounted motor, small flange;  
IM B14 (IM 3601)

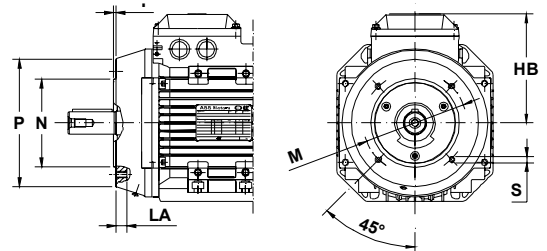

IM B3 (IM 1001), IM 1002

Motor size	A	AA	AB	AC	AE	B	BB	C	CA	CB	D	DA	DB	DC	E	EA	EG	EH	F	FA
56	90	18	108	110	72	71	85	36	78	7	9	9	M3	M3	20	20	9	9	3	3
63	100	26	120	120	72	80	96	40	71	8	11	11	M4	M4	23	23	10	10	4	4
71	112	24	136	130	85	90	110	45	78	10	14	11	M5	M4	30	23	13	10	5	4
80	125	28	154	150	97	100	125	50	80	12.5	19	14	M6	M5	40	30	16	13	6	5
90 S	140	27	170	177	110	100	125	56	81	12.5	24	14	M8	M5	50	30	19	12.5	8	5
90 L	140	27	170	177	110	125	150	56	81	12.5	24	14	M8	M5	50	30	19	12.5	8	5
100	160	32	197	197	110	140	172	63	91	16	28	19	M10	M6	60	40	22	19	8	6

Motor size	G	GA	GB	GC	H	HA	HC	HD	HE	K	KA	L	LC	UB	UC	VA	VB	VC	VD
56	7.2	10.2	7.2	10.2	56	8	110	159	71	5.8	9	197	225	Pg11	M16x1.5	30	72	26	53
63	8.5	12.5	8.5	12.5	63	10	120	171	76	7	11	205	237	Pg11	M16x1.5	36	72	26	53
71	11	16	8.5	12.5	71	9	130	176	63	7	10	238	266	Pg16	M20x1.5	35	92	22	57
80	15.5	21.5	11	16	80	10	150	190	67	10	15	265	300	Pg16	M20x1.5	37	100	26	61
90 S	20	27	11	16	90	11	177	217	82.5	10	14	282	317	M25x1.5	M25x1.5	43.5	110	33	67
90 L	20	27	11	16	90	11	177	217	82.5	10	14	307	342	M25x1.5	M25x1.5	43.5	110	33	67
100	24	31	15.5	21.5	100	12	198	237	92.5	12	15	349	394	M25x1.5	M25x1.5	47	110	33	67

IM B5 (IM 3001), IM 3002

Motor size	HB	LA	M	N	P	S	T
56	103	10	100	80	120	7	3
63	108	10	115	95	140	10	3
71	105	10	130	110	160	10	3.5
80	110	12	165	130	200	12	3.5
90	127	10	165	130	200	12	3.5
100	137	11	215	180	250	15	4

IM B14 (IM 3601), IM 3602

Motor size	HB	LA	M	N	P	S	T
56	103	10	65	50	80	M5	2.5
63	108	10	75	60	90	M5	2.5
71	105	10	85	70	105	M6	2.5
80	110	10	100	80	120	M6	3
90	127	13	115	95	140	M8	3
100	137	14	130	110	160	M8	3.5

Tolerances:

A, B	+ - 0.8	H	+0 -0.5
D, DA	ISO j6	N	ISO j6
F, FA	ISO h9	C, CA	+ - 0.8

Above table gives the main dimensions in mm.  
For detailed drawings please see our web-pages  
'www.abb.com/motors&drives' or contact us.

# General purpose aluminium motors

# Sizes 56-100

## Dimension drawings

Foot- and flange-mounted motor;  
IM B35 (IM 2001), IM 2002, large flange

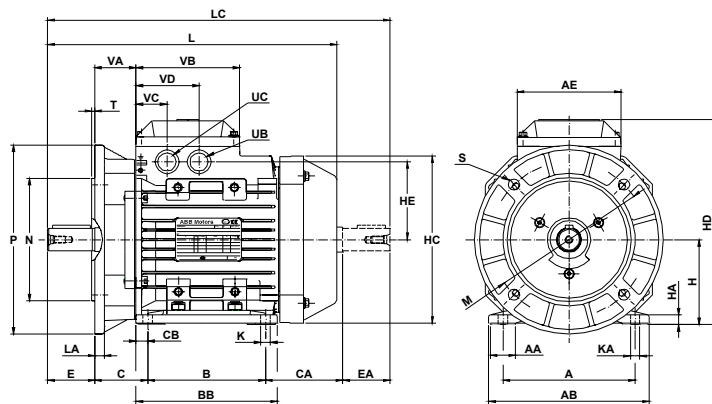

Foot- and flange-mounted motor;  
IM B34 (IM 2101), IM 2102, small flange

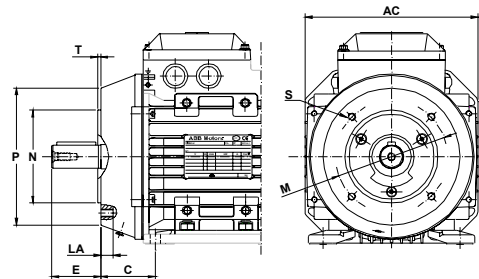

### IM B35 (IM 2001), IM 2002, IM B34 (IM 2101), IM 2102

Motor size	A	AA	AB	AC	AE	B	BB	C	CA	CB	D	DA	DB	DC	E	EA	EG	EH	F	FA
56	90	18	108	110	72	71	85	36	78	7	9	9	M3	M3	20	20	9	9	3	3
63	100	26	120	120	72	80	96	40	71	8	11	11	M4	M4	23	23	10	10	4	4
71	112	24	136	130	85	90	110	45	78	10	14	11	M5	M4	30	23	13	10	5	4
80	125	28	154	150	97	100	125	50	80	12.5	19	14	M6	M5	40	30	16	13	6	5
90 S	140	27	170	177	110	100	125	56	81	12.5	24	14	M8	M5	50	30	19	12.5	8	5
90 L	140	27	170	177	110	125	150	56	81	12.5	24	14	M8	M5	50	30	19	12.5	8	5
100	160	32	197	197	110	140	172	63	91	16	28	19	M10	M6	60	40	22	19	8	6

Motor size	G	GA	GB	GC	H	HA	HC	HD	HE	K	KA	L	LC	UB	UC	VA	VB	VC	VD
56	7.2	10.2	7.2	10.2	56	8	110	159	71	5.8	9	197	225	Pg11	M16x1.5	30	72	26	53
63	8.5	12.5	8.5	12.5	63	10	120	171	76	7	11	205	237	Pg11	M16x1.5	36	72	26	53
71	11	16	8.5	12.5	71	9	130	176	63	7	10	238	266	Pg16	M20x1.5	35	92	22	57
80	15.5	21.5	11	16	80	10	150	190	67	10	15	265	300	Pg16	M20x1.5	37	100	26	61
90 S	20	27	11	16	90	10	177	217	82.5	10	14	282	317	M25x1.5	M25x1.5	43.5	110	33	67
90 L	20	27	11	16	90	10	177	217	82.5	10	14	307	342	M25x1.5	M25x1.5	43.5	110	33	67
100	24	31	15.5	21.5	100	12	197	237	92.5	12	15	349	394	M25x1.5	M25x1.5	47	110	33	67

### IM B35 (IM 2001), IM 2002

Motor size	HB	LA	M	N	P	S	T
56	103	10	100	80	120	7	3
63	108	10	115	95	140	10	3
71	105	10	130	110	160	10	3.5
80	110	12	165	130	200	12	3.5
90	127	10	165	130	200	12	3.5
100	137	11	215	180	250	15	4

### IM B34 (IM 2101), IM 2102

Motor size	HB	LA	M	N	P	S	T
56	103	10	65	50	80	M5	2.5
63	108	10	75	60	90	M5	2.5
71	105	10	85	70	105	M6	2.5
80	110	10	100	80	120	M6	3
90	127	13	115	95	140	M8	3
100	137	14	130	110	160	M8	3.5

Tolerances:

A, B	+ - 0.8	H	+0 -0.5
D, DA	ISO j6	N	ISO j6
F, FA	ISO h9	C, CA	+ - 0.8

Above table gives the main dimensions in mm.

For detailed drawings please see our web-pages  
'[www.abb.com/motors&drives](http://www.abb.com/motors&drives)' or contact us.

# General purpose aluminium motors

# Sizes 71-100

## Dimension drawings

## Special design with two-piece flanges

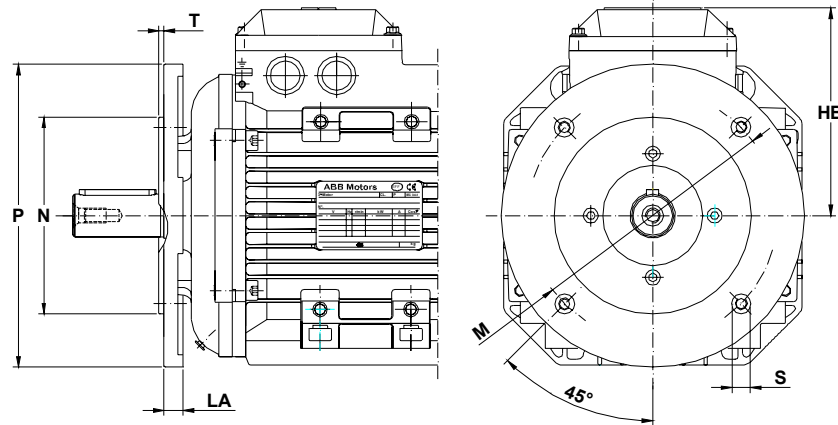

Motor size	IEC Flange	Flange dimensions							Variant code <sup>1)</sup>	
		HB	P	M	N	LA	S <sup>2)</sup>	T	FF	FT
<b>71</b>	FT85	105	105	85	70	7.5	M6	2.5	-	218
	FF100 / FT100	105	120	100	80	7.5	M6	3	220	219
	FF115 / FT115	105	140	115	95	9.5	M8	3	223	224
	FF130 / FT130	105	160	130	110	9.5	M8	3.5	226	227
	FF165 / FT165	105	200	165	130	10.5	M10	3.5	233	234
<b>80</b>	FT85	110	105	85	70	7.5	M6	2.5	-	218
	FF100 / FT100	110	120	100	80	7.5	M6	3	220	219
	FF115 / FT115	110	140	115	95	9.5	M8	3	223	224
	FF130 / FT130	110	160	130	110	9.5	M8	3.5	226	227
	FF165 / FT165	110	200	165	130	10.5	M10	3.5	233	234
<b>90</b>	FT85	127	105	85	70	7.5	M6	2.5	-	218
	FF100 / FT100	127	120	100	80	7.5	M6	3	220	219
	FF115 / FT115	127	140	115	95	9.5	M8	3	223	224
	FF130 / FT130	127	160	130	110	9.5	M8	3.5	226	227
	FF165 / FT165	127	200	165	130	10.5	M10	3.5	233	234
<b>100</b>	FF130 / FT130	137	160	130	110	9.5	M8	3.5	226	227
	FF165 / FT165	137	200	165	130	10.5	M10	3.5	233	234
	FF215 / FT215	137	250	215	180	12.5	M12	4	243	244

Data for smaller frame sizes on request.

<sup>1)</sup> Variant code 200 'Flange ring holder' must be added when using the variant codes mentioned below.

<sup>2)</sup> Flanges with clearance (FF) or tapped (FT) holes for indicated screws.

Tolerances:

N ISO j6

# General purpose aluminium motors

# Sizes 112-132

## Dimension drawings

### Foot-mounted motor; IM B 3 (IM 1001), IM 1002

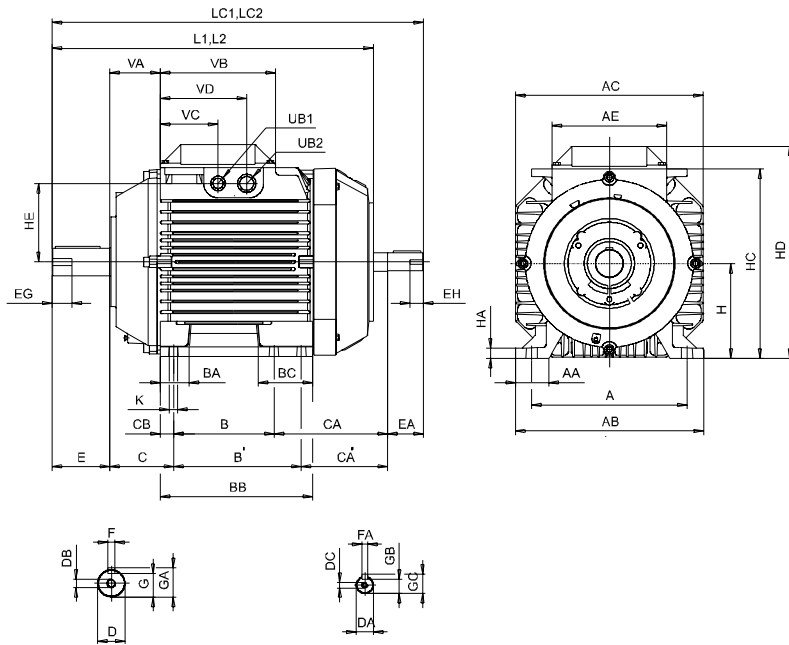

### Flange-mounted motor, large flange; IM B 5 (IM 3001), IM 3002

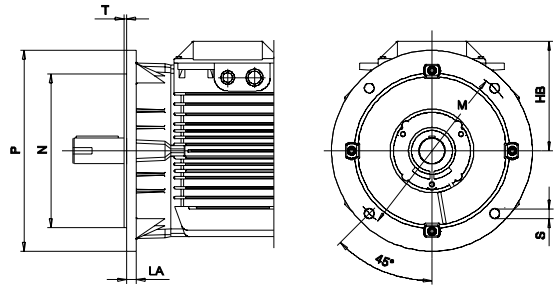

### Flange-mounted motor, small flange; IM B 14 (IM 3601), IM 3602

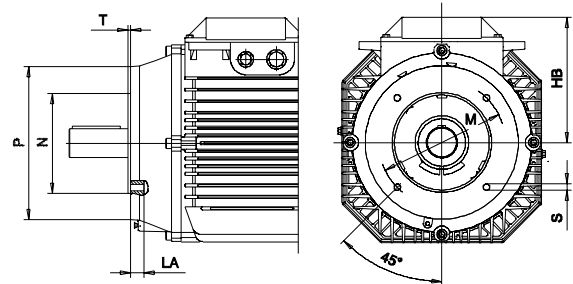

### IM B 3 (IM 1001)

Motor size	A	AA	AB	AC	AE	B	B'	BA	BB	BC	C	CA	CA'	CB	D	DA	DB	DC	E <sup>B)</sup>	EA	EG	EH	F	FA
112 <sup>1)</sup>	190	41	222	221	160	140	-	31	168	31	70	115.5	-	14	28	19	M10	M8	60	40	22	19	8	6
112 <sup>2)</sup>	190	41	222	221	160	140	-	31	168	31	70	138	-	14	28	19	M10	M8	60	40	22	19	8	6
132 <sup>3)</sup>	216	47	262	261	160	140	178 <sup>A)</sup>	40	212	76	89	158	120	18	38	24	M12	M8	80	50	28	19	10	8
132 <sup>4)</sup>	216	47	262	261	160	140 <sup>A)</sup>	178	40	212	76	89	191	153	18	38	24	M12	M8	80	50	28	19	10	8

Motor size	G	GAGB	GC	H	HA	HC	HD	HE	K	L	L1	L2	LC	LC1	LC2	UB1 <sup>C)</sup>	UB2 <sup>C)</sup>	VA	VB	VC <sup>D)</sup>	VD1	VD2	
112 <sup>1)</sup>	24	31	15.5	21.5	112	12	226	258	92	12	361 <sup>F)</sup>	361 <sup>F)</sup>	361 <sup>F)</sup>	421.5	421.5	421.5	M20	M25	60	160	80	120	40
112 <sup>2)</sup>	24	31	15.5	21.5	112	12	226	258	92	12	388 <sup>F)</sup>	388 <sup>F)</sup>	388 <sup>F)</sup>	448	448	448	M20	M25	60	160	80	120	40
132 <sup>3)</sup>	33	41	20	27	132	14	263.5	295.5	109.5	12	447 <sup>G)</sup>	447 <sup>G)</sup>	447 <sup>G)</sup>	517	517	517	M20	M25	71	160	80	120	40
132 <sup>4)</sup>	33	41	20	27	132	14	263.5	295.5	109.5	12	481.5 <sup>G)</sup>	481.5 <sup>G)</sup>	481.5 <sup>G)</sup>	550	550	550	M20	M25	71	160	80	120	40

### IM B 5 (IM 3001)

Motor size	HB	LA	M	N	P	S	T
112 <sup>1)</sup>	146	11	215	180	250	14.5	4
112 <sup>2)</sup>	146	11	215	180	250	14.5	4
132 <sup>3)</sup>	163.5	14	265	230	300	14.5	4
132 <sup>4)</sup>	163.5	14	265	230	300	14.5	4

### IM B14 (IM 3601)

Motor size	HB	LA	M	N	P	S	T
112 <sup>1)</sup>	146	20	130	110	160	M8	3.5
112 <sup>2)</sup>	146	20	130	110	160	M8	3.5
132 <sup>3)</sup>	163.5	18	165	130	200	M10	3.5
132 <sup>4)</sup>	163.5	18	165	130	200	M10	3.5

**Tolerances**  
 A, B ISO js14  
 C, CA +2 -2  
 D28 ISO j6  
 D38 ISO k6  
 DA ISO j6  
 F, FA ISO h9  
 H +0 -0.5  
 N ISO j6

<sup>1)</sup> M2AA: M-2, M-4. M3AA: M-6, M8  
<sup>2)</sup> all 112 excl <sup>1)</sup>  
<sup>3)</sup> M2AA: SA-2, SB-2, S-4, M-4. M3AA: SA-2, S-4, S-6, MA-6, MB-6, S-8, M-8, S-Two-speed  
<sup>4)</sup> all 132 excl <sup>3)</sup>

<sup>A)</sup> Not acc to IEC.  
<sup>B)</sup> For IM B5 and IM B35: Shoulder of shaft extension and contact surface of flange are in the same plane.  
<sup>C)</sup> Knockout openings.  
<sup>D)</sup> Dimensions to UB1.

<sup>E)</sup> Dimensions to UB2 (VD1 = right side, VD2 = left side) as viewed from the D-end.  
<sup>F)</sup> For variant code 053 increased by 7.5mm  
<sup>G)</sup> For variant code 053 increased by 5.5mm

Above table gives the main dimensions in mm. For detailed drawings please see our web-pages [www.abb.com/motors&drives](http://www.abb.com/motors&drives) or contact us.



# General purpose aluminium motors

## Dimension drawings

# Sizes 112-132

Foot- and flange-mounted motor; IM B 35 (IM 2001), IM 2002, large flange

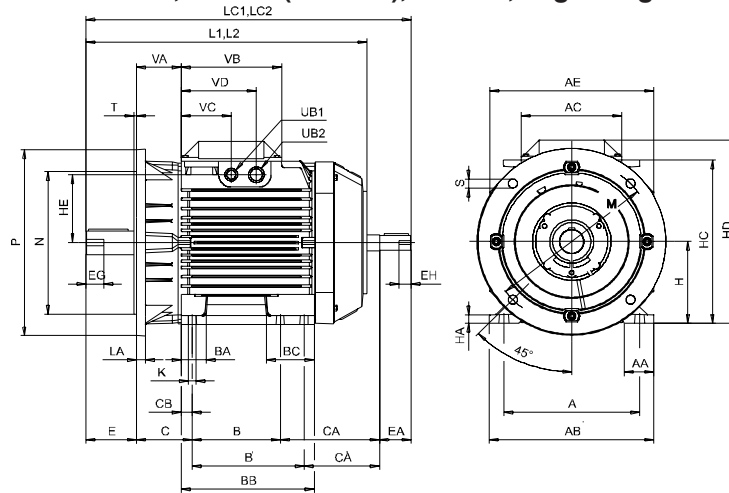

Foot- and flange-mounted motor; IM B 34 (IM 2101), IM 2102, small flange

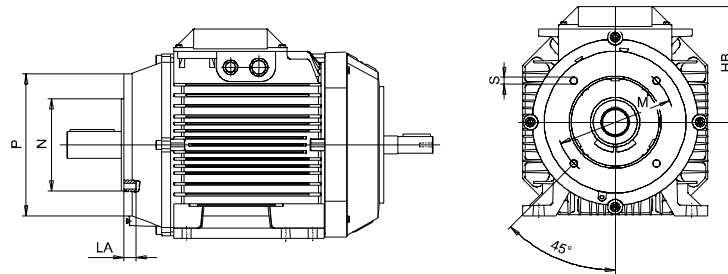

### IM B 35 (IM 2001), IM 2002

Motor size	A	AA	AB	AC	AE	B	B'	BA	BB	BC	C	CA	CA'	CB	D	DA	DB	DC	E <sup>B)</sup>	EA	EG	EH	F	FA
112 <sup>1)</sup>	190	41	222	221	160	140	-	31	168	31	70	115.5	-	14	28	19	M10	M8	60	40	22	19	8	6
112 <sup>2)</sup>	190	41	222	221	160	140	-	31	168	31	70	138	-	14	28	19	M10	M8	60	40	22	19	8	6
132 <sup>3)</sup>	216	47	262	261	160	140	178 <sup>A)</sup>	40	212	76	89	158	120	18	38	24	M12	M8	80	50	28	19	10	8
132 <sup>4)</sup>	216	47	262	261	160	140 <sup>A)</sup>	178	40	212	76	89	191	153	18	38	24	M12	M8	80	50	28	19	10	8

Motor size	G	GAGB	GC	H	HA	HC	HD	HE	K	L	L1	L2	LC	LC1	LC2	UB1 <sup>C)</sup>	UB2 <sup>C)</sup>	VA	VB	VC <sup>D)</sup>	VD1	VD2
112 <sup>1)</sup>	24	31	15.5	21.5	112	12	226	258	92	12	361 <sup>F)</sup>	361 <sup>F)</sup>	421.5	421.5	421.5	M20	M25	60	160	80	120	40
112 <sup>2)</sup>	24	31	15.5	21.5	112	12	226	258	92	12	388 <sup>F)</sup>	388 <sup>F)</sup>	448	448	448	M20	M25	60	160	80	120	40
132 <sup>3)</sup>	33	41	20	27	132	14	263.5	295.5	109.5	12	447 <sup>G)</sup>	447 <sup>G)</sup>	517	517	517	M20	M25	71	160	80	120	40
132 <sup>4)</sup>	33	41	20	27	132	14	263.5	295.5	109.5	12	481.5 <sup>G)</sup>	481.5 <sup>G)</sup>	550	550	550	M20	M25	71	160	80	120	40

### IM B 35 (IM 2001)

Motor size	HB	LA	M	N	P	S	T
112 <sup>1)</sup>	146	11	215	180	250	14.5	4
112 <sup>2)</sup>	146	11	215	180	250	14.5	4
132 <sup>3)</sup>	163.5	14	265	230	300	14.5	4
132 <sup>4)</sup>	163.5	14	265	230	300	14.5	4

### IM B 34 (IM 2101)

Motor size	HB	LA	M	N	P	S	T
112 <sup>1)</sup>	146	20	130	110	160	M8	3.5
112 <sup>2)</sup>	146	20	130	110	160	M8	3.5
132 <sup>3)</sup>	163.5	18	165	130	200	M10	3.5
132 <sup>4)</sup>	163.5	18	165	130	200	M10	3.5

#### Tolerances

A, B ISO js14  
 C, CA +2-2  
 D28 ISO j6  
 D38 ISO k6  
 DA ISO j6  
 F, FA ISO h9  
 H +0-0.5  
 N ISO j6

- 1) M2AA: M-2, M-4. M3AA: M-6, M8
- 2) all 112 excl 1)
- 3) M2AA: SA-2, SB-2, S-4, M-4. M3AA: SA-2, S-4, S-6, MA-6, MB-6, S-8, M-8, S-Two-speed
- 4) all 132 excl 3)

- A) not acc to IEC.
- B) For IM B5 and IM B35: Shoulder of shaft extension and contact surface of flange are in the same plane.
- C) Knockout openings.
- D) Dimensions to UB1.

- E) Dimensions to UB2 (VD1 = right side, VD2 = left side) as viewed from the D-end.
- F) For variant code 053 increased by 7.5mm
- G) For variant code 053 increased by 5.5mm

Above table gives the main dimensions in mm. For detailed drawings please see our web-pages 'www.abb.com/motors&drives' or contact us.

# General purpose aluminium motors M2AA 160-200

## Dimension drawings

Foot-mounted motor; IM B3 (IM 1001), IM 1002

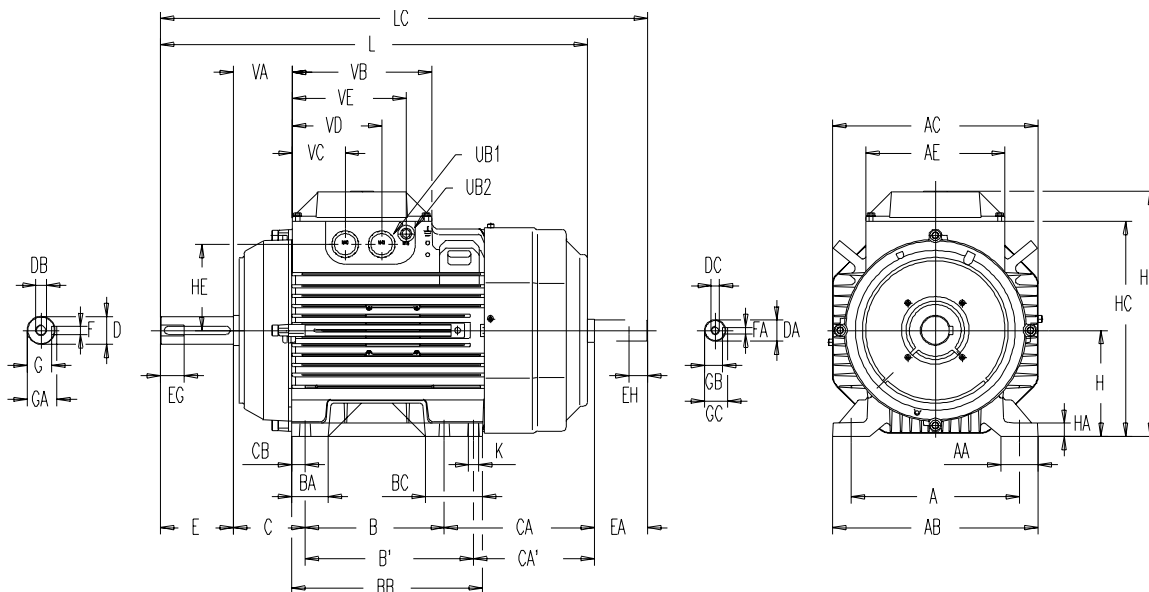

### IM B3 (IM 1001), IM 1002

Motor size	A	AA	AB	AC	AE	B <sup>8)</sup>	B' <sup>8)</sup>	BA	BB	BC	C	CA	CA'	CB	D	DA	DB	DC	E	EA	EG	EH	F <sup>1)</sup>
160 <sup>3)</sup>	254	56	310	310	210	210	254	55	287.5	86	108	185.5	141.5	20	42	32	M16	M12	110	80	36	28	12
180 <sup>4)</sup>	279	65.5	340	310	210	241	279	58	316	88	121	185.5	141.5	25	48	32	M16	M12	110	80	36	28	14
180 <sup>5)</sup>	279	65.5	340	310	210	241	279	58	316	88	121	226.5	182.5	25	48	32	M16	M12	110	80	36	28	14
200 <sup>6)</sup>	318	64	380	360	210	267	305	98	365	98	133	218	180	30	55	32	M20	M12	110	80	42	28	16
200 <sup>7)</sup>	318	64	380	360	210	267	305	98	365	98	133	238	200	30	55	32	M20	M12	110	80	42	28	16

Motor size	FA	G	GA	GB	GC	H	HA	HC	HD	HE	K	L	LC	UB1 <sup>2)</sup>	UB2 <sup>2)</sup>	VA	VB	VC	VD	VE
160 <sup>3)</sup>	10	37	45	27	35	160	20	325	370	130	15	602.5	693.5	2*M40	M16	89	210	84.5	134.5	167.5
180 <sup>4)</sup>	10	42.5	51.5	27	35	180	20	345	390	130	15	602.5	693.5	2*M40	M16	89	210	84.5	134.5	167.5
180 <sup>5)</sup>	10	42.5	51.5	27	35	180	20	345	390	130	15	643.5	734.5	2*M40	M16	89	210	84.5	134.5	167.5
200 <sup>6)</sup>	10	49	59	27	35	200	25	380	425	145	18	711.5	801.5	2*M40	M16	109	210	84.5	134.5	167.5
200 <sup>7)</sup>	10	49	59	27	35	200	25	380	425	145	18	732	821.5	2*M40	M16	109	210	84.5	134.5	167.5

#### Tolerances

A, B ISO js14  
 C, CA 0 +2  
 DA 32 ISO k6  
 D 45-48 ISO k6  
 D 55 ISO m6  
 F, FA ISO h9  
 H +0 -0.5

<sup>2)</sup> Knockout openings.

<sup>3)</sup> MA-2, M-2, L-2, M-4, L-4

<sup>4)</sup> M-2, M-4

<sup>5)</sup> L-4

<sup>6)</sup> LA-4

<sup>7)</sup> L-2, L-4

<sup>8)</sup> 160 M, 180 M: B' not acc. to IEC

160 L, 180 L, 200 LA: B not acc. to IEC

Above table gives the main dimensions in mm.  
 For detailed drawings please see our web-pages  
[www.abb.com/motors&drives](http://www.abb.com/motors&drives) or contact us.

# General purpose aluminium motors

## Dimension drawings

# M2AA 160-200

### Flange-mounted motor; IM B5 (IM 3001), IM 3002

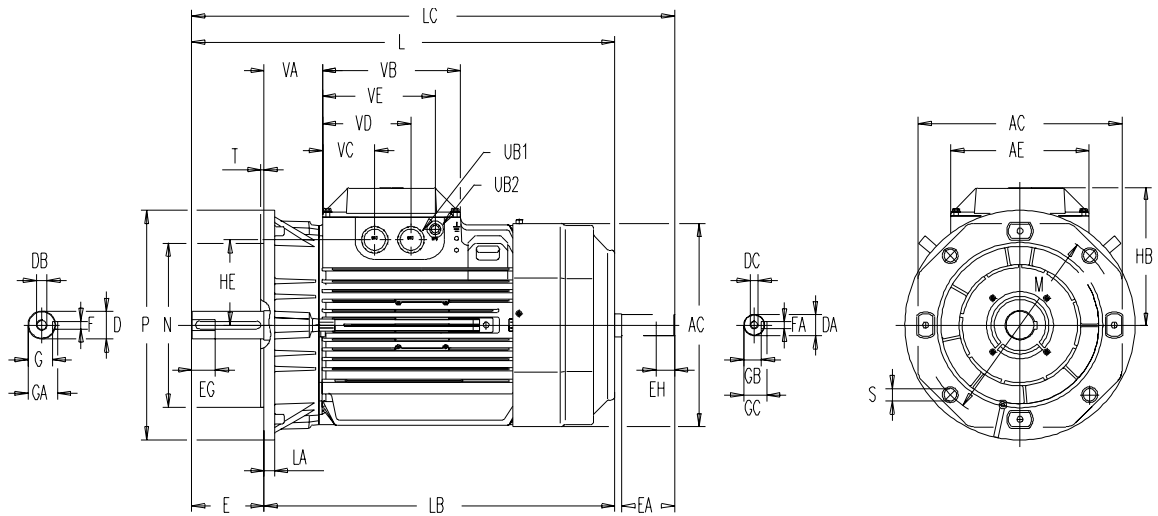

### IM B5 (IM 3001), IM 3002

Motor size	AC	AE	D	DA	DB	DC	E <sup>8)</sup>	EA	EG	EH	F <sup>1)</sup>	FA	G	GA	GB	GC	HB	HE
160 <sup>3)</sup>	310	210	42	32	M16	M12	110	80	36	28	12	10	37	45	27	35	210	130
180 <sup>4)</sup>	310	210	48	32	M16	M12	110	80	36	28	14	10	42.5	51.5	27	35	210	130
180 <sup>5)</sup>	310	210	48	32	M16	M12	110	80	36	28	14	10	42.5	51.5	27	35	210	130
200 <sup>6)</sup>	360	210	55	32	M20	M12	110	80	42	28	16	10	49	59	27	35	210	145
200 <sup>7)</sup>	360	210	55	32	M20	M12	110	80	42	28	16	10	49	59	27	35	210	145

Motor size	L	LA	LB	LC	M	N	P	S	T	UB1 <sup>2)</sup>	UB2 <sup>2)</sup>	VA	VB	VC	VD	VE
160 <sup>3)</sup>	602.5	16	492.5	693.5	300	250	350	19	5	2*M40	M16	89	210	79.5	134.5	171.5
180 <sup>4)</sup>	602.5	16	492.5	693.5	300	250	350	19	5	2*M40	M16	89	210	79.5	134.5	171.5
180 <sup>5)</sup>	643.5	16	533.5	734.5	300	250	350	19	5	2*M40	M16	89	210	79.5	134.5	171.5
200 <sup>6)</sup>	711.5	20	601.5	801.5	350	300	400	19	5	2*M40	M16	109	210	79.5	134.5	171.5
200 <sup>7)</sup>	732	20	622	821.5	350	300	400	19	5	2*M40	M16	109	210	79.5	134.5	171.5

#### Tolerances

DA 32 ISO k6  
 D 45-48 ISO k6  
 D 55 ISO m6  
 F, FA ISO h9  
 N ISO j6

2) Knockout openings.

3) MA-2, M-2, L-2, M-4, L-4

4) M-2, M-4

5) L-4

6) LA-2

7) L-2, L-4

8) Shoulder of shaft extension and contact surface of flange are in the same plane.

Above table gives the main dimensions in mm.  
 For detailed drawings please see our web-pages  
[www.abb.com/motors&drives](http://www.abb.com/motors&drives) or contact us.

# General purpose aluminium motors

# M2AA 160-200

## Dimension drawings

Foot- and flange-mounted motor; IM B35 (IM 2001), IM 2002

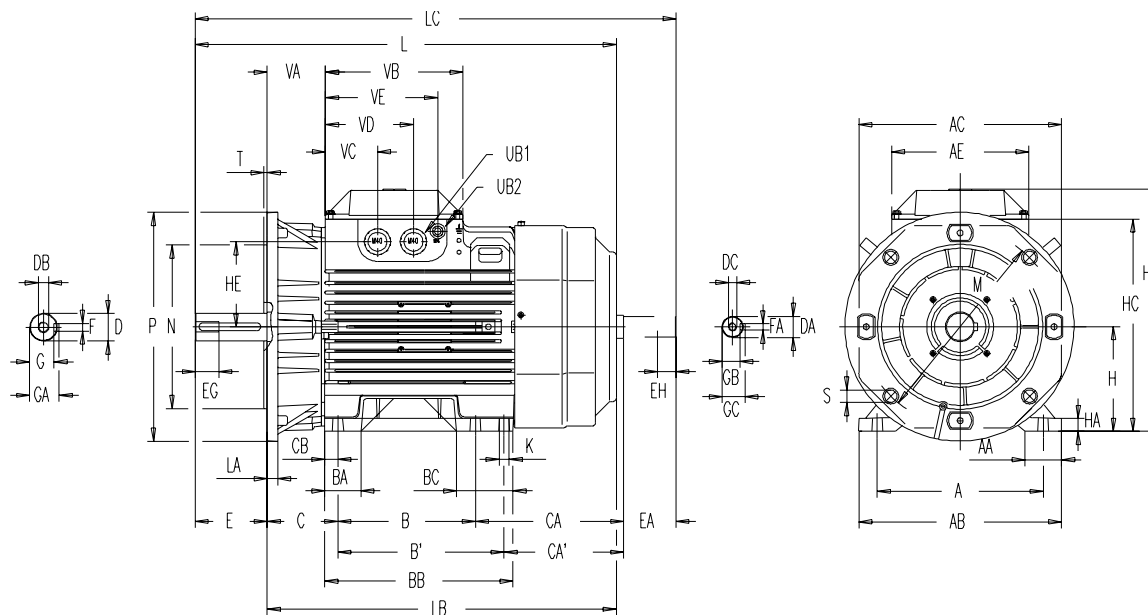

### IM B35 (IM 2001), IM 2002

Motor size	A	AA	AB	AC	AE	B <sup>9)</sup>	B' <sup>9)</sup>	BA	BB	BC	C	CA	CA'	CB	D	DA	DB	DC
160 <sup>3)</sup>	254	56	310	310	210	210	254	55	287.5	86	108	185.5	141.5	20	42	32	M16	M12
180 <sup>4)</sup>	279	65.5	340	310	210	241	279	58	316	88	121	185.5	141.5	25	48	32	M16	M12
180 <sup>5)</sup>	279	65.5	340	310	210	241	279	58	316	88	121	226.5	182.5	25	48	32	M16	M12
200 <sup>6)</sup>	318	64	380	360	210	267	305	98	365	98	133	218	180	30	55	32	M20	M12
200 <sup>7)</sup>	318	64	380	360	210	267	305	98	365	98	133	238	200	30	55	32	M20	M12

Motor size	E <sup>8)</sup>	EA	EG	EH	F	FA	G	GA	GB	GC	H	HA	HB	HC	HD	HE	K	L
160 <sup>3)</sup>	110	80	36	28	12	10	37	45	27	35	160	20	325	370	130	15	602.5	
180 <sup>4)</sup>	110	80	36	28	14	10	42.5	51.5	27	35	180	20	345	390	130	15	602.5	
180 <sup>5)</sup>	110	80	36	28	14	10	42.5	51.5	27	35	180	20	345	390	130	15	643.5	
200 <sup>6)</sup>	110	80	42	28	16	10	49	59	27	35	200	25	380	425	145	18	711.5	
200 <sup>7)</sup>	110	80	42	28	16	10	49	59	27	35	200	25	380	425	145	18	732	

Motor size	LA	LB	LC	M	N	P	S	T	UB1 <sup>2)</sup>	UB2 <sup>2)</sup>	VA	VB	VC	VD	VE
160 <sup>3)</sup>	16	492.5	693.5	300	250	350	19	5	2*M40	M16	89	210	79.5	134.5	171.5
180 <sup>4)</sup>	20	492.5	693.5	300	250	350	19	5	2*M40	M16	89	210	79.5	134.5	171.5
180 <sup>5)</sup>	20	533.5	734	300	250	350	19	5	2*M40	M16	89	210	79.5	134.5	171.5
200 <sup>6)</sup>	20	601.5	801.5	350	300	400	19	5	2*M40	M16	109	210	79.5	134.5	171.5
200 <sup>7)</sup>	20	622.0	821.5	350	300	400	19	5	2*M40	M16	109	210	79.5	134.5	171.5

#### Tolerances

A, B ISO js14  
 C, CA +0 -2  
 DA32 ISO k6  
 D45-48 ISO k6  
 D55 ISO m6  
 F, FA ISO h9  
 H +0 - 0.5  
 N ISO j6

<sup>2)</sup> Knockout openings.

<sup>3)</sup> MA-2, M-2, L-2, M-4, L-4

<sup>4)</sup> M-2, M-4

<sup>5)</sup> L-4

<sup>6)</sup> LA-2

<sup>7)</sup> L-2, L-4

<sup>8)</sup> Shoulder of shaft extension and contact surface of flange are in the same plane.

<sup>9)</sup> 160 M, 180 M: B' not acc. to IEC.

160 L, 180 L, 200 LA: B not acc. to IEC.

Above table gives the main dimensions in mm.

For detailed drawings please see our web-pages  
[www.abb.com/motors&drives](http://www.abb.com/motors&drives) or contact us.

# General purpose aluminium motors

## Dimension drawings

# M2AA 225-250

Foot-mounted motor; IM B3 (IM 1001), IM 1002

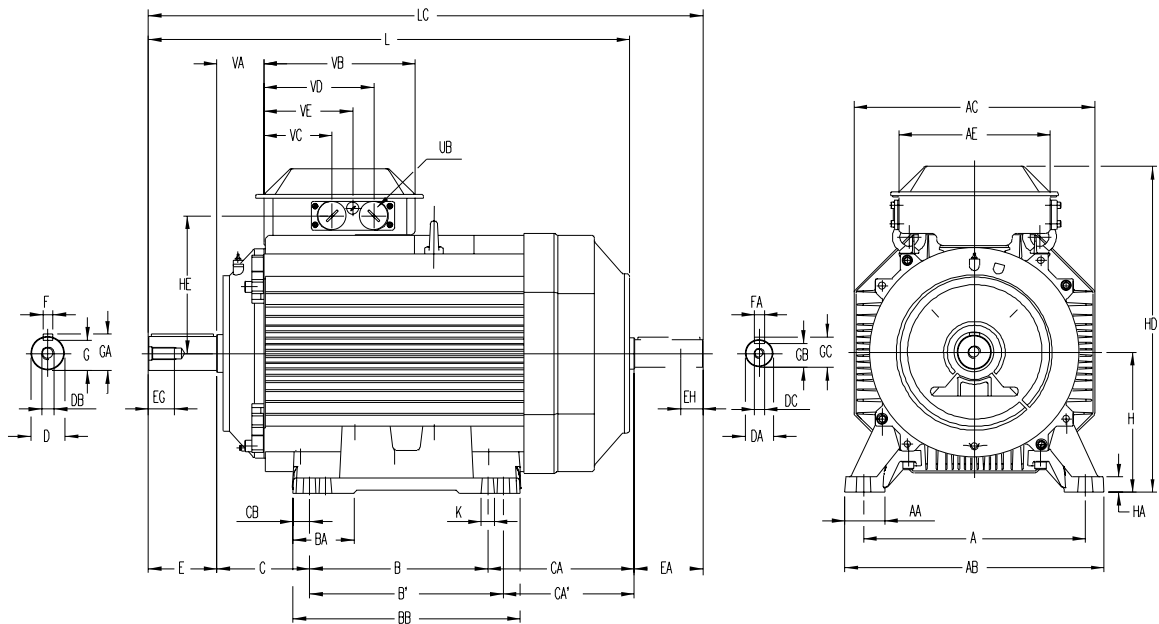

Dimension AD and HD refer to side mounted terminal box, see page 73.

### IM B3 (IM 1001), IM 1002

Motor size	A	AA	AB	AC	AE	B <sup>5)</sup>	B'	BA	BB	C	CA	CA'	CB	D	DA	DB	DC	E	EA	EG	EH
225 M-2	356	64	416	386	243	286 <sup>7)</sup>	311	81.5	365	149	238	213	27	55	45	M20	M16	110	110	42	36
225 S-4	356	64	416	386	243	286	311 <sup>8)</sup>	81.5	365	149	238	213	27	60	45	M20	M16	140	110	42	36
225 M-4	356	64	416	386	243	286 <sup>7)</sup>	311	81.5	365	149	278	253	27	60	45	M20	M16	140	110	42	36
250 M-2	406	76	472	425	243	311 <sup>7)</sup>	349	99.5	409	168	256	218	30	60	55	M20	M20	140	110	42	42
250 M-4	406	76	472	425	243	311 <sup>7)</sup>	349	99.5	409	168	256	218	30	65	55	M20	M20	140	110	42	42

Motor size	F	FA	G	GA	GB	GC	H	HA	HD	HE	K	L	LC	UB <sup>2)</sup>	VA	VB	VC <sup>3)</sup>	VC <sup>4)</sup>	VD <sup>3)</sup>	VD <sup>4)</sup>
225 M-2	16	16	49	59	39	49	225	25	525.5	221	18	773	893	2xFL 13	75.5	243	109.5	81.5	176.5	171.5
225 S-4	18	16	53	64	39	49	225	25	525.5	221	18	803	923	2xFL 13	75.5	243	109.5	81.5	176.5	171.5
225 M-4	18	16	53	64	39	49	225	25	525.5	221	18	843	963	2xFL 13	75.5	243	109.5	81.5	176.5	171.5
250 M-2	18	16	53	64	49	59	250	40	571	241	22	866	985	2xFL 13	93.5	243	109.5	81.5	176.5	171.5
250 M-4	18	16	58	69	49	59	250	40	571	241	22	866	985	2xFL 13	93.5	243	109.5	81.5	176.5	171.5

Motor size	VE <sup>3)</sup>	VE <sup>4)</sup>
225 M-2	143	126.5
225 S-4	143	126.5
225 M-4	143	126.5
250 M-2	143	126.5
250 M-4	143	126.5

Tolerances  
 A, B ISO js14  
 C, CA 0 +2  
 DA 45 ISO k6  
 D, DA 55-65 ISO m6  
 F, FA ISO h9  
 H +0 - 0.5

- 2) Flange opening is provided with pipe flange FL 13, with tapped lead-in holes plugged with sealing plugs. Single- and two-speed motors: 2 x M40 + M16. Motors for 230 V 50 Hz have pipe flange FL 21 and 2 x M63 + M16.
- 3) For flange opening FL 13: 2 x M40 + M16.
- 4) For extra large terminal box with flange opening FL 21: 2 x M63 + M16.
- 5) Basic design only.
- 6) Dimension CB = 30 for high output design.
- 7) Not according to IEC for M.
- 8) Not according to IEC for S.

Above table gives the main dimensions in mm.  
 For detailed drawings please see our web-pages  
[www.abb.com/motors&drives](http://www.abb.com/motors&drives) or contact us.

# General purpose aluminium motors

# M2AA 225-250

## Dimension drawings

Flange-mounted motor; IM B5 (IM 3001), IM 3002

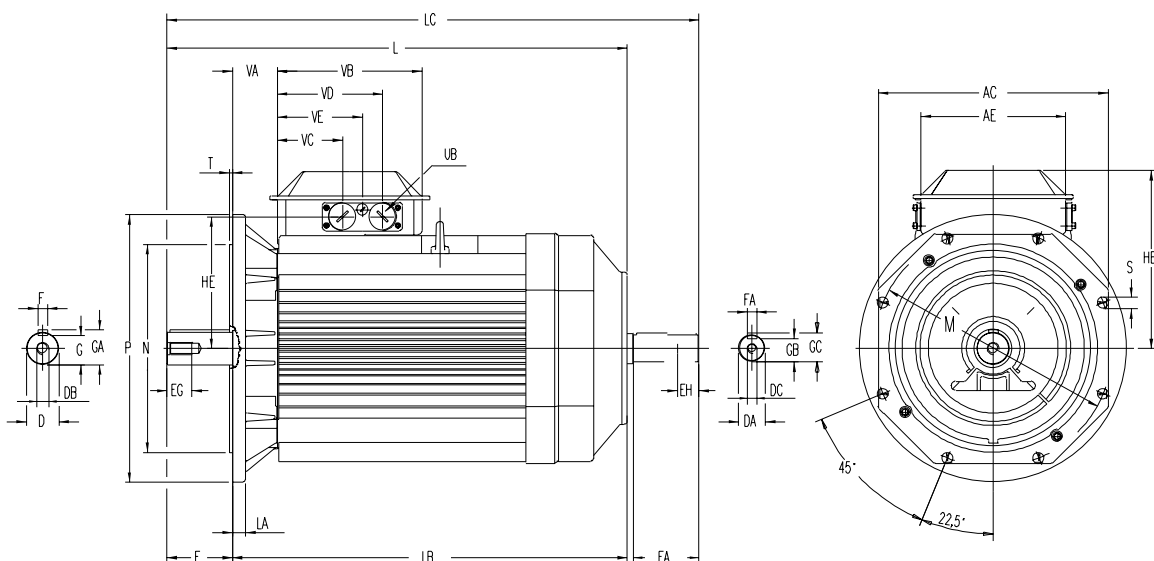

### IM B5 (IM 3001), IM 3002

Motor size	AC	AE	D	DA	DB	DC	E <sup>2)</sup>	EA	EG	EH	F	FA	G	GA	GB	GC	HB	HE
225 M-2	386	243	55	45	M20	M16	110	110	42	36	16	16	49	59	39	49	300.5	221
225 S-4	386	243	60	45	M20	M16	140	110	42	36	18	16	53	64	39	49	300.5	221
225 M-4	386	243	60	45	M20	M16	140	110	42	36	18	16	53	64	39	49	300.5	221
250 M-2	425	243	60	55	M20	M20	140	110	42	42	18	16	53	64	49	59	321	241
250 M-4	425	243	65	55	M20	M20	140	110	42	42	18	16	58	69	49	59	321	241

Motor size	L	LA	LB	LC	M	N	P	S	T	UB <sup>3)</sup>	VA	VB	VC <sup>4)</sup>	VC <sup>5)</sup>	VD <sup>4)</sup>	VD <sup>5)</sup>	VE <sup>4)</sup>	VE <sup>5)</sup>
225 M-2	773	22	663	893	400	350	450	19	5	2 x FL 13	75.5	243	109.5	81.5	176.5	171.5	143	126.5
225 S-4	803	22	663	923	400	350	450	19	5	2 x FL 13	75.5	243	109.5	81.5	176.5	171.5	143	126.5
225 M-4	843	22	703	963	400	350	450	19	5	2 x FL 13	75.5	243	109.5	81.5	176.5	171.5	143	126.5
250 M-2	866	22	725	985	500	450	550	19	5	2 x FL 13	93.5	243	109.5	81.5	176.5	171.5	143	126.5
250 M-4	866	22	725	985	500	450	550	19	5	2 x FL 13	93.5	243	109.5	81.5	176.5	171.5	143	126.5

Tolerances  
 DA 45 ISO k6  
 D, DA 55-60 ISO m6  
 F, FA ISO h9  
 N ISO js6

<sup>2)</sup> Shoulder of shaft extension and contact surface of flange are in the same plane.

<sup>3)</sup> Flange opening is provided with pipe flange FL 13, with tapped lead-in holes plugged with sealing plugs.  
 Single- and two-speed motors: 2 x M40 + M16.  
 Motors for 230 V 50 Hz have pipe flange FL 21 and 2 x M63 + M16.

<sup>4)</sup> For flange opening FL 13: 2 x M40 + M16.

<sup>5)</sup> For extra large terminal box with flange opening FL 21: 2 x M63 + M16.

Above table gives the main dimensions in mm.  
 For detailed drawings please see our web-pages  
[www.abb.com/motors&drives](http://www.abb.com/motors&drives) or contact us.



# General purpose aluminium motors M3AA 160-180

## Dimension drawings

Foot-mounted motor; IM B3 (IM 1001), IM 1002

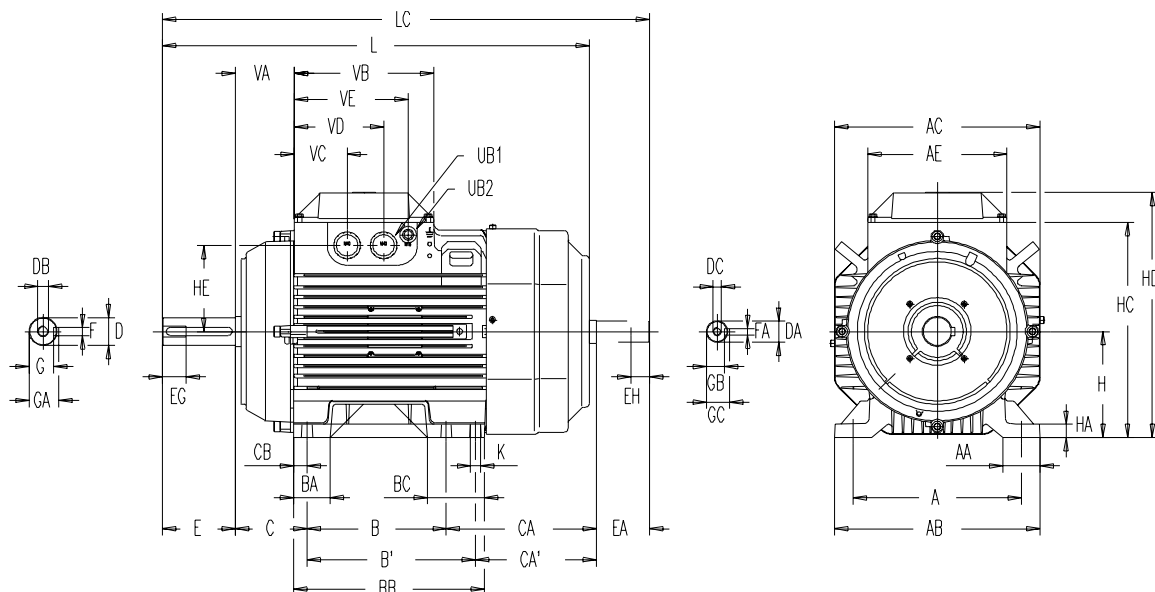

### IM B3 (IM 1001), IM 1002

Motor size	A	AA	AB	AC	AE	B <sup>7)</sup>	B' <sup>7)</sup>	BA	BB	BC	C	CA	CA'	CB	D	DA	DB	DC	E	EA	EG	EH	F <sup>1)</sup>
160 <sup>3)</sup>	254	56	310	310	210	210	254	55	287.5	86	108	185.5	141.5	20	42	32	M16	M12	110	80	36	28	12
160 <sup>4)</sup>	254	56	310	310	210	210	254	55	287.5	86	108	226.5	182.5	20	42	32	M16	M12	110	80	36	28	12
180 <sup>5)</sup>	279	65.5	340	360	210	241	279	58	316	88	121	218	180	25	48	32	M16	M12	110	80	36	28	14
180 <sup>6)</sup>	279	65.5	340	360	210	241	279	58	316	88	121	238	200	25	48	32	M16	M12	110	80	36	28	14

Motor size	FA	G	GA	GB	GC	H	HA	HC	HD	HE	K	L	LC	UB1 <sup>2)</sup>	UB2 <sup>2)</sup>	VA	VB	VC	VD	VE
160 <sup>3)</sup>	10	37	45	27	35	160	20	325	370	130	15	602.5	693.5	2*M40	M16	89	210	84.5	134.5	167.5
160 <sup>4)</sup>	10	37	45	27	35	160	20	325	370	130	15	643.5	734.5	2*M40	M16	89	210	84.5	134.5	167.5
180 <sup>5)</sup>	10	42.5	51.5	27	35	180	20	360	405	145	15	680	770	2*M40	M16	77.5	210	84.5	134.5	167.5
180 <sup>6)</sup>	10	42.5	51.5	27	35	180	20	360	405	145	15	700.5	790	2*M40	M16	77.5	210	84.5	134.5	167.5

#### Tolerances

A, B ISO js14  
 C, CA +2 -2  
 D, DA ISO k6  
 F, FA ISO h9  
 H +0 -0.5

<sup>2)</sup> Knockout openings.

<sup>3)</sup> M-2, MA-2, M-4, M-6, M-8, MA-8, L-2, L-4, L-6, MA-2/4, M-2/4, L-2/4, M-4/6, M-4/8, LB-2, LB-4

<sup>4)</sup> L-8, L-4/6, L-4/8, LB-6, LB-8

<sup>5)</sup> M-2, M-4, L-6, L-8, M-2/4, M-4/6, M-4/8, LB-2

<sup>6)</sup> L-4, L-2/4, L-4/6, L-4/8, LB-4, LB-6, LB-8

<sup>7)</sup> 160 M, 180 M: B' not acc. to IEC

160 L, 180 L: B not acc. to IEC

Above table gives the main dimensions in mm.  
 For detailed drawings please see our web-pages  
[www.abb.com/motors&drives](http://www.abb.com/motors&drives) or contact us.



# General purpose aluminium motors

## Dimension drawings

# M3AA 160-180

Flange-mounted motor; IM B5 (IM 3001), IM 3002

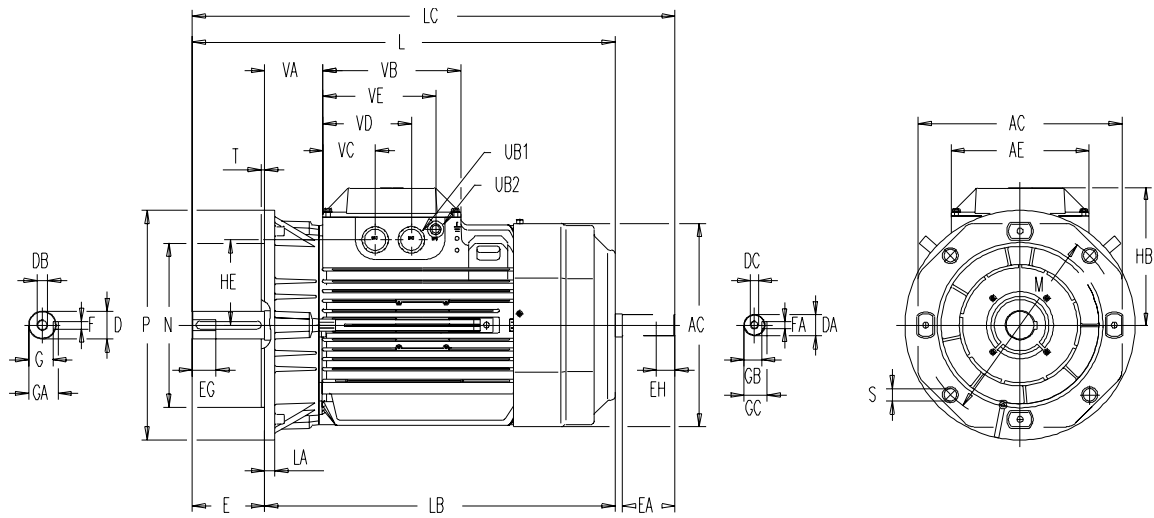

### IM B5 (IM 3001), IM 3002

Motor size	AC	AE	D	DA	DB	DC	E <sup>7)</sup>	EA	EG	EH	F <sup>1)</sup>	FA	G	GA	GB	GC	HB	HE
160 <sup>3)</sup>	310	210	42	32	M16	M12	110	80	36	28	12	10	37	45	27	35	210	130
160 <sup>4)</sup>	310	210	42	32	M16	M12	110	80	36	28	12	10	37	45	27	35	210	130
180 <sup>5)</sup>	360	210	48	32	M16	M12	110	80	36	28	14	10	42.5	51.5	27	35	225	145
180 <sup>6)</sup>	360	210	48	32	M16	M12	110	80	36	28	14	10	42.5	51.5	27	35	225	145

Motor size	L	LA	LB	LC	M	N	P	S	T	UB1 <sup>2)</sup>	UB2 <sup>2)</sup>	VA	VB	VC	VD	VE
160 <sup>3)</sup>	602.5	16	492.5	693.5	300	250	350	19	5	2*M40	M16	89	210	79.5	134.5	171.5
160 <sup>4)</sup>	643.5	16	533.5	734.5	300	250	350	19	5	2*M40	M16	89	210	79.5	134.5	171.5
180 <sup>5)</sup>	680	21	570	770	300	250	350	19	5	2*M40	M16	77.5	210	79.5	134.5	171.5
180 <sup>6)</sup>	700.5	21	590.5	790	300	250	350	19	5	2*M40	M16	77.5	210	79.5	134.5	171.5

**Tolerances**

D, DA ISO k6  
 F, FA ISO h9  
 N ISO j6

<sup>2)</sup> Knockout openings.

<sup>3)</sup> M-2, MA-2, M-4, M-6, M-8, MA-8, L-2, L-4, L-6, MA-2/4, M-2/4, L-2/4, M-4/6, M-4/8, LB-2, LB-4

<sup>4)</sup> L-8, L-4/6, L-4/8, LB-6, LB-8

<sup>5)</sup> M-2, M-4, L-6, L-8, M-2/4, M-4/6, M-4/8, LB-2

<sup>6)</sup> L-4, L-2/4, L-4/6, L-4/8, LB-4, LB-6, LB-8

<sup>7)</sup> Shoulder of shaft extension and contact surface of flange are in the same plane.

Above table gives the main dimensions in mm.  
 For detailed drawings please see our web-pages  
[www.abb.com/motors&drives](http://www.abb.com/motors&drives) or contact us.



# General purpose aluminium motors M3AA 200-225

## Dimension drawings

Foot-mounted motor; IM B3 (IM 1001), IM 1002

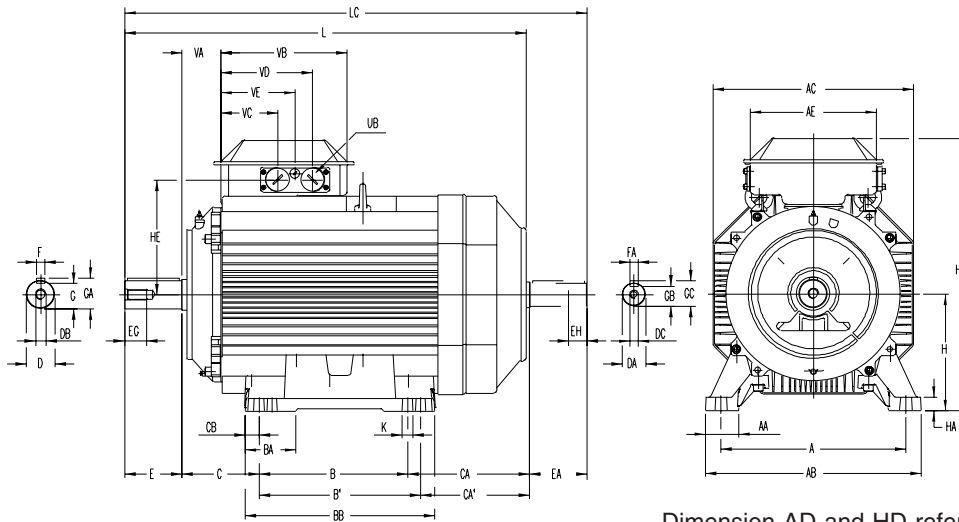

Dimension AD and HD refer to side mounted terminal box, see page 73.

### IM B3 (IM 1001), IM 1002

Motor size	A	AA	AB	AC	AE	B	B'	BA	BB	C	CA	CA'	CB	D	DA	DB	DC	E <sup>D)</sup>	EA	EG	EH	F	FA
200 <sup>1)</sup>	318	64	380	386	243	267	305	98	365	133	273	235	30	55	45	M20	M16	110	110	42	36	16	16
200 <sup>2)</sup>	318	64	380	386	243	267	305	98	365	133	313	275	30	55	45	M20	M16	110	110	42	36	16	16
225 <sup>3)</sup>	356	69	418	425	243	286	311	84	360	149	300	275	24.5	55	55	M20	M20	110	110	42	42	16	16
225 <sup>4)</sup>	356	69	418	425	243	286	311	84	360	149	325	300	24.5	55	55	M20	M20	110	110	42	42	16	16
225 <sup>5)</sup>	356	69	418	425	243	286	311	84	360	149	300	275	24.5	60	55	M20	M20	140	110	42	42	18	16
225 <sup>6)</sup>	356	69	418	425	243	286	311	84	360	149	325	300	24.5	60	55	M20	M20	140	110	42	42	18	16

Motor size	G	GA	GB	GC	H	HA	HD <sup>B)</sup>	HD <sup>C)</sup>	HE	K	L	LC	UB <sup>A)</sup>	VA	VB	VC <sup>B)</sup>	VC <sup>C)</sup>	VD <sup>B)</sup>	VD <sup>C)</sup>	VE <sup>B)</sup>	VE <sup>C)</sup>
200 <sup>1)</sup>	49	59	39	49	200	25	500.5	533	224	18	774	893	2xFL13	75.5	243	109.5	81.5	176.5	171.5	143	126.5
200 <sup>2)</sup>	49	59	39	49	200	25	500.5	533	224	18	814	933	2xFL13	75.5	243	109.5	81.5	176.5	171.5	143	126.5
225 <sup>3)</sup>	49	59	49	59	225	25	546	578	244.5	18	836	955	2xFL13	93.5	243	109.5	81.5	176.5	171.5	143	126.5
225 <sup>4)</sup>	49	59	49	59	225	25	546	578	244.5	18	861	980	2xFL13	93.5	243	109.5	81.5	176.5	171.5	143	126.5
225 <sup>5)</sup>	53	64	49	59	225	25	546	578	244.5	18	866	985	2xFL13	93.5	243	109.5	81.5	176.5	171.5	143	126.5
225 <sup>6)</sup>	53	64	49	59	225	25	546	578	244.5	18	891	1100	2xFL13	93.5	243	109.5	81.5	176.5	171.5	143	126.5

#### Tolerances

A, B	ISO js14
C, CA	+0 -2
D 55-65	ISO m6
DA 45-55	ISO k6
F, FA	ISO h9
H	+0 -0.5
N	ISO j6

- 1) all 200 excl 2)
- 2) MLD-2, MLC-4
- 3) SMB-2, SMC-2, SM\_-2/4
- 4) SMD-2,
- 5) all 225 excl 3) 4) 6)
- 6) SMD-4

Above table gives the main dimensions in mm.  
For detailed drawings please see our web-pages  
'[www.abb.com/motors&drives](http://www.abb.com/motors&drives)' or contact us.

# General purpose aluminium motors

# M3AA 200-225

## Dimension drawings

Flange-mounted motor; IM B5 (IM 3001), IM 3002

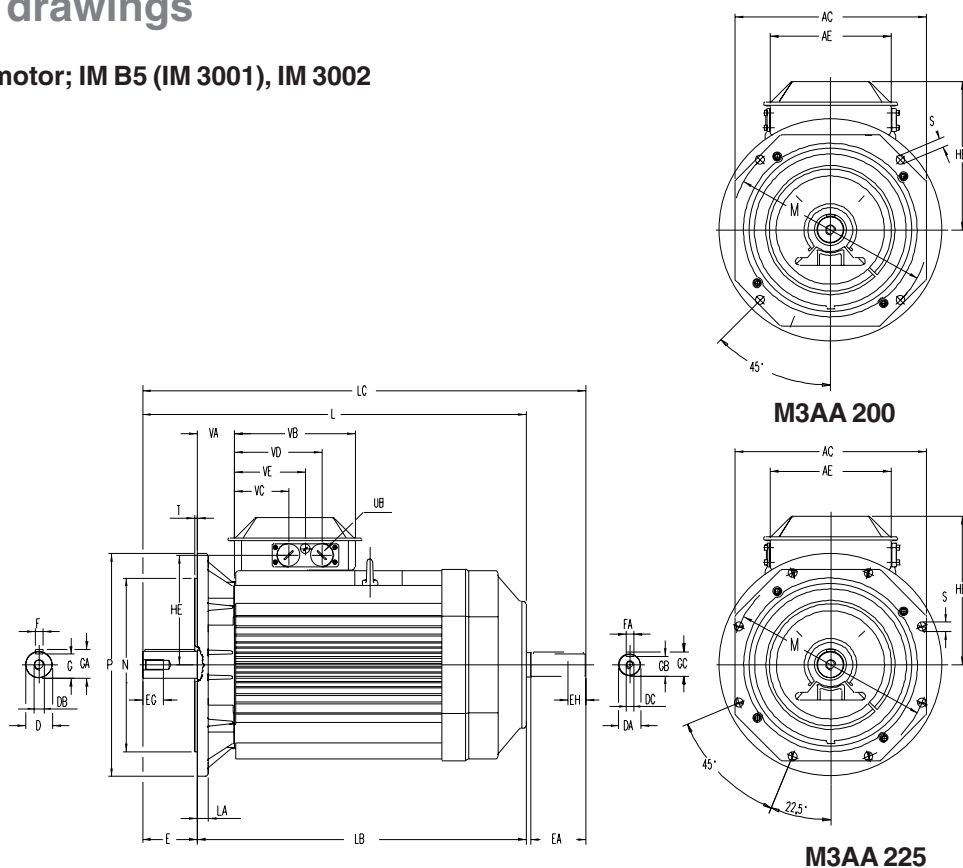

IM B5 (IM 3001), IM 3002

Motor size	AC	AE	D	DA	DB	DC	E <sup>D)</sup>	EA	EG	EH	F	FA	G	GA	GB	GC	HB <sup>B)</sup>	HB <sup>C)</sup>	HE
200 <sup>1)</sup>	386	243	55	45	M20	M16	110	110	42	36	16	16	49	59	39	49	301	333	224
200 <sup>2)</sup>	386	243	55	45	M20	M16	110	110	42	36	16	16	49	59	39	49	301	333	224
225 <sup>3)</sup>	425	243	55	55	M20	M20	110	110	42	42	16	16	49	59	49	59	321	353	244.5
225 <sup>4)</sup>	425	243	55	55	M20	M20	110	110	42	42	16	16	49	59	49	59	321	353	244.5
225 <sup>5)</sup>	425	243	60	55	M20	M20	140	110	42	42	18	16	53	64	49	59	321	353	244.5
225 <sup>6)</sup>	425	243	60	55	M20	M20	140	110	42	42	18	16	53	64	49	59	321	353	244.5

Motor size	L	LA	LB	LC	M	N	P	S	T	UB <sup>A)</sup>	VA	VB	VC <sup>B)</sup>	VC <sup>C)</sup>	VD <sup>B)</sup>	VD <sup>C)</sup>	VE <sup>B)</sup>	VE <sup>C)</sup>
200 <sup>1)</sup>	774	20	664	893	350	300	400	19	5	2xFL13	75.5	243	109.5	81.5	176.5	171.5	143	126.5
200 <sup>2)</sup>	814	20	704	933	350	300	400	19	5	2xFL13	75.5	243	109.5	81.5	176.5	171.5	143	126.5
225 <sup>3)</sup>	836	22	726	955	400	350	450	19	5	2xFL13	93.5	243	109.5	81.5	176.5	171.5	143	126.5
225 <sup>4)</sup>	861	22	751	980	400	350	450	19	5	2xFL13	93.5	243	109.5	81.5	176.5	171.5	143	126.5
225 <sup>5)</sup>	866	22	726	985	400	350	450	19	5	2xFL13	93.5	243	109.5	81.5	176.5	171.5	143	126.5
225 <sup>6)</sup>	891	22	751	1100	400	350	450	19	5	2xFL13	93.5	243	109.5	81.5	176.5	171.5	143	126.5

### Tolerances

A, B	ISO js14
C, CA	+0 -2
D 55-65	ISO m6
DA 45-55	ISO k6
F, FA	ISO h9
H	+0 -0.5
N	ISO j6

1) all 200 excl 2)

2) MLD-2, MLC-4

3) SMB-2, SMC-2, SM\_-2/4

4) SMD-2,

5) all 225 excl 3) 4) 6)

6) SMD-4

A) Flange opening is provided with pipe flange FL 13, with tapped lead-in holes plugged with sealing plugs 2 x M40 + M16.

Motors for 230VD 50Hz have pipe flange FL21 and 2 x M63 + M16

B) For flange opening FL13: 2 x M40 + M16

C) For extra large flange opening FL21: 2 x M63 + M16

D) For IM B5 and IM B35: Shoulder of shaft extension and contact surface of flange are in the same plane.

Above table gives the main dimensions in mm.

For detailed drawings please see our web-pages 'www.abb.com/motors&drives' or contact us.

# General purpose aluminium motors

## Dimension drawings

# M3AA 200-225

Foot- and flange-mounted motor; IM B35 (IM 2001), IM 2002

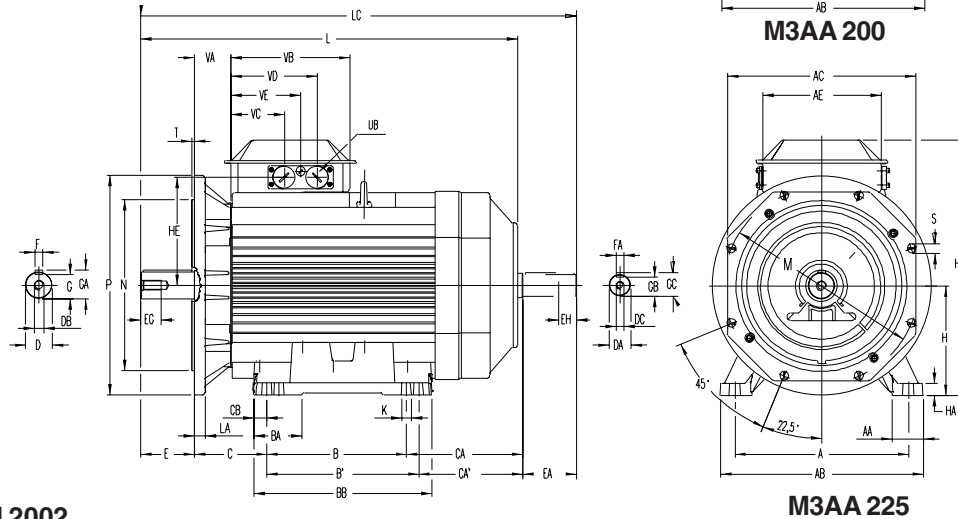

IM B35 (IM 2001), IM 2002

Motor size	A	AA	AB	AC	AE	B	B'	BA	BB	C	CA	CA'	CB	D	DA	DB	DC	E <sup>D)</sup>	EA	EG	EH	F	FA	G	GA	GB	GC
200 <sup>1)</sup>	318	64	380	386	243	267	305	98	365	133	273	235	30	55	45	M20	M16	110	110	42	36	16	16	49	59	39	49
200 <sup>2)</sup>	318	64	380	386	243	267	305	98	365	133	313	275	30	55	45	M20	M16	110	110	42	36	16	16	49	59	39	49
225 <sup>3)</sup>	356	69	418	425	243	286	311	84	360	149	300	275	25	55	55	M20	M20	110	110	42	42	16	16	49	59	49	59
225 <sup>4)</sup>	356	69	418	425	243	286	311	84	360	149	325	300	25	55	55	M20	M20	110	110	42	42	16	16	49	59	49	59
225 <sup>5)</sup>	356	69	418	425	243	286	311	84	360	149	300	275	25	60	55	M20	M20	140	110	42	42	18	16	53	64	49	59
225 <sup>6)</sup>	356	69	418	425	243	286	311	84	360	149	325	300	25	60	55	M20	M20	140	110	42	42	18	16	53	64	49	59

Motor size	H	HA	HB <sup>B)</sup>	HB <sup>C)</sup>	HD <sup>B)</sup>	HD <sup>C)</sup>	HE	K	L	LA	LB	LC	M	N	P	S	T	UB <sup>A)</sup>	VA	VB	VC <sup>B)</sup>	VC <sup>C)</sup>	VD <sup>B)</sup>	VD <sup>C)</sup>	VE <sup>B)</sup>	VE <sup>C)</sup>
200 <sup>1)</sup>	200	25	301	333	501	533	224	18	774	20	664	893	350	300	400	19	5	2xFL13	75.5	243	110	81.5	176.5	171.5	143	126.5
200 <sup>2)</sup>	200	25	301	333	501	533	224	18	814	20	704	933	350	300	400	19	5	2xFL13	75.5	243	110	81.5	176.5	171.5	143	126.5
225 <sup>3)</sup>	225	25	321	353	546	578	245	18	836	22	726	955	400	350	450	19	5	2xFL13	93.5	243	110	81.5	176.5	171.5	143	126.5
225 <sup>4)</sup>	225	25	321	353	546	578	245	18	861	22	751	980	400	350	450	19	5	2xFL13	93.5	243	110	81.5	176.5	171.5	143	126.5
225 <sup>5)</sup>	225	25	321	353	546	578	245	18	866	22	726	985	400	350	450	19	5	2xFL13	93.5	243	110	81.5	176.5	171.5	143	126.5
225 <sup>6)</sup>	225	25	321	353	546	578	245	18	891	22	751	1100	400	350	450	19	5	2xFL13	93.5	243	110	81.5	176.5	171.5	143	126.5

### Tolerances

A, B	ISO js14
C, CA	+0 -2
D 55-65	ISO m6
DA 45-55	ISO k6
F, FA	ISO h9
H	+0 -0.5
N	ISO j6

- 1) all 200 excl 2)
- 2) MLD-2, MLC-4
- 3) SMB-2, SMC-2, SM\_-2/4
- 4) SMD-2
- 5) all 225 excl 3) 4) 6)
- 6) SMD-4

- A) Flange opening is provided with pipe flange FL 13, with tapped lead-in holes plugged with sealing plugs 2 x M40 + M16. Motors for 230V 50Hz have pipe flange FL21 and 2 x M63 + M16
- B) For flange opening FL13: 2 x M40 + M16
- C) For extra large flange opening FL21: 2 x M63 + M16
- D) For IM B5 and IM B35: Shoulder of shaft extension and contact surface of flange are in the same plane.

Above table gives the main dimensions in mm.  
For detailed drawings please see our web-pages  
'[www.abb.com/motors&drives](http://www.abb.com/motors&drives)' or contact us.



# General purpose aluminium motors

# M3AA 250-280

## Dimension drawings

Flange-mounted motor; IM B5 (IM 3001), IM 3002

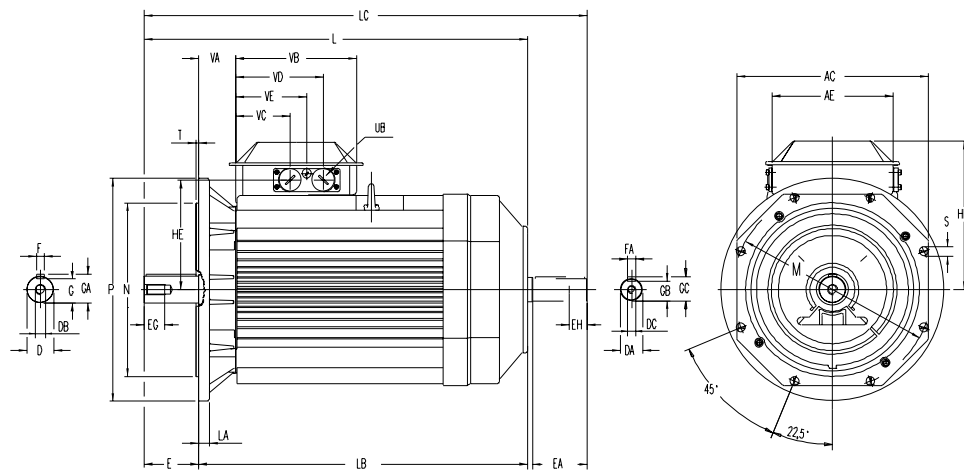

M3AA 250-280

### IM B5 (IM 3001), IM 3002

Motor size	AC	AE	D	DA	DB	DC	E <sup>D)</sup>	EA	EG	EH	F	FA	G	GA	GB	GC	HB <sup>B)</sup>	HB <sup>C)</sup>	HE
250 <sup>7)</sup>	471	243	60	55	M20	M20	140	110	42	42	18	16	53	64	49	59	344	376	267.5
250 <sup>8)</sup>	471	243	60	55	M20	M20	140	110	42	42	18	16	53	64	49	59	344	376	267.5
250 <sup>9)</sup>	471	243	65	55	M20	M20	140	110	42	42	18	16	58	69	49	59	344	376	267.5
250 <sup>10)</sup>	471	243	65	55	M20	M20	140	110	42	42	18	16	58	69	49	59	344	376	267.5
280 <sup>11)</sup>	471	243	65	55	M20	M20	140	110	42	42	18	16	58	69	49	59	-	376	283.5
280 <sup>12)</sup>	471	243	65	55	M20	M20	140	110	42	42	18	16	58	69	49	59	-	376	283.5
280 <sup>13)</sup>	471	243	75	55	M20	M20	140	110	42	42	20	16	67.5	79.5	49	59	-	376	283.5
280 <sup>14)</sup>	471	243	75	55	M20	M20	140	110	42	42	20	16	67.5	79.5	49	59	-	376	283.5

Motor size	L	LA	LB	LC	M	N	P	S	T	UB <sup>A)</sup>	VA	VB	VC <sup>B)</sup>	VC <sup>C)</sup>	VD <sup>B)</sup>	VD <sup>C)</sup>	VE <sup>B)</sup>	VE <sup>C)</sup>
250 <sup>1)</sup>	875	25	735	992	500	450	550	19	5	2xFL13	93.5	243	109.5	81.5	176.5	171.5	143	126.5
250 <sup>2)</sup>	900	25	760	1017	500	450	550	19	5	2xFL13	93.5	243	109.5	81.5	176.5	171.5	143	126.5
250 <sup>3)</sup>	875	25	735	992	500	450	550	19	5	2xFL13	93.5	243	109.5	81.5	176.5	171.5	143	126.5
250 <sup>4)</sup>	900	25	760	1017	500	450	550	19	5	2xFL13	93.5	243	109.5	81.5	176.5	171.5	143	126.5
280 <sup>5)</sup>	875	25	735	992	500	450	550	19	5	2xFL21	93.5	243	-	76.5	-	166.5	-	121.5
280 <sup>6)</sup>	900	25	760	1017	500	450	550	19	5	2xFL21	93.5	243	-	76.5	-	166.5	-	121.5
280 <sup>7)</sup>	875	25	735	992	500	450	550	19	5	2xFL21	93.5	243	-	76.5	-	166.5	-	121.5
280 <sup>8)</sup>	900	25	760	1017	500	450	550	19	5	2xFL21	93.5	243	-	76.5	-	166.5	-	121.5

#### Tolerances

A, B	ISO js14
C, CA	+0 -2
D 55-65	ISO m6
DA 45-55	ISO k6
F, FA	ISO h9
H	+0 -0.5
N	ISO j6

- 1) SMA-2, SMB-2, SMB2/4
- 2) SMC-2
- 3) all 250 excl 1) 2) 4)
- 4) SMC-4
- 5) SMA-2
- 6) SMB-2
- 7) SMA-4-8
- 8) SMB-4

- A) Flange opening is provided with pipe flange FL 13, with tapped lead-in holes plugged with sealing plugs 2 x M40 + M16. Motors for 230VD 50Hz have pipe flange FL21 and 2 x M63 + M16
- B) For flange opening FL13: 2 x M40 + M16
- C) For extra large flange opening FL21: 2 x M63 + M16
- D) For IM B5 and IM B35: Shoulder of shaft extension and contact surface of flange are in the same plane.

Above table gives the main dimensions in mm.

For detailed drawings please see our web-pages 'www.abb.com/motors&drives' or contact us.





# Dimensions for terminal box

**Code 019** Larger than standard terminal box

Motor size	Dimensions			
	AD	HB	HD	HE
M2AA 225 S/M	-	332.5	532.5	240
M2AA 250 M	-	353	578	260.5
M3AA 200 ML.	332.5	332.5	532.5	240
M3AA 225 SM.	353	353	578	260.5
M3AA 250 SM.	376	376	626	283.5

**Code 021** Terminal box on left-hand side seen from D end

**Code 180** Terminal box on right-hand side seen from D end

Motor size	Dimensions	
	AD	HD
M2AA 225 - 250	On request	
M3AA 200 ML.	300.5	412.5
M3AA 225 SM.	321	452
M3AA 250 SM.	344	494
M3AA 280	376	524

**Code 467** M2AA 160-250 on request.

Lower than standard terminal box without screw terminals and extended rubber connection cable 2 m.

Frame sizes 112-180 have standard terminal box with low, flat cover.

Motor size	Dimensions		
	AD	HB	HD
112 M		123.5	235.5
132 S		141	273
132 M		141	273
160		211.5	371.5
180		226.5	406.5
200 ML.	248	248	448
225 SM.	269	269	494
250 SM.	292	292	542
280	292	292	572

# Accessories

## Protective roof and variable speed drives

**Protective roof**  
Variant code 005

**Tacho**  
Variant codes; 472, 473, 572 and 573

**Separate cooling with or without tacho**  
Variant codes; 183, 474, 476, 477, 189, 574, 576 and 577

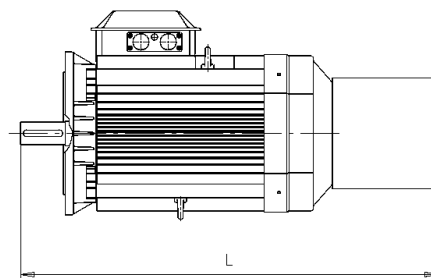
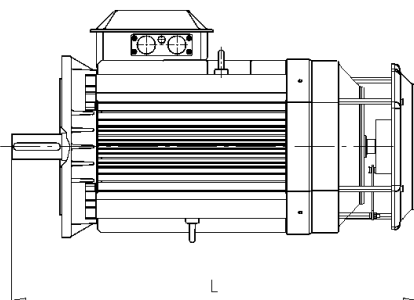
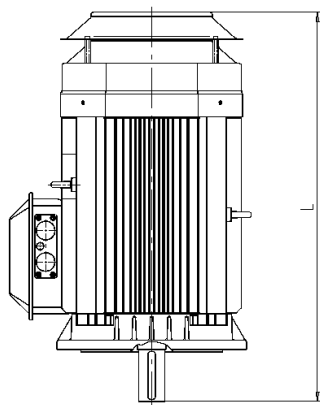

Variant codes	005	183	189	472, 473 572, 573	474, 476 477, 574 576, 577
Motor size	L	L	L	L	L
56	216	-	-	-	-
63	224	-	275	-	-
71	261	352	287	304	352
80	288	373	313	326	373
90 S	318	<sup>1)</sup>	<sup>1)</sup>	<sup>1)</sup>	<sup>1)</sup>
90 L	343	<sup>1)</sup>	<sup>1)</sup>	<sup>1)</sup>	<sup>1)</sup>
100 L	385	<sup>1)</sup>	<sup>1)</sup>	<sup>1)</sup>	<sup>1)</sup>

<sup>1)</sup> On request.

Variant codes; M2AA	Pole	005	183	189	472, 473 572, 573	474, 476 477, 574 576, 577
Motor size		L	L	L	L	L
112	2-4	400	-	493.5	458.5	543.5
132	2-4	484	-	580.5	542	630.5
160 <sup>1)</sup>	2-4	653.5	1015.5	870.5	697	1015.5
180 <sup>2)</sup>	2-4	653.5	1015.5	870.5	697	1015.5
180 <sup>3)</sup>	4	694.5	1056.5	911.5	738	1056.5
200 <sup>4)</sup>	4	762.5	1128.5	983.5	806	1128.5
200 <sup>5)</sup>	2-4	783	1149	1004	826.5	1149
225 M	2	824	1233	1088	867	1233
225 S	4	854	1263	1118	897	1263
225 M	4	894	1303	1158	937	1303
250 M	2-4	915	1325	1180	960	1325

<sup>1)</sup> MA-2, M-2, L-2, M-4, L-4

<sup>2)</sup> M-2, M-4

<sup>3)</sup> L-4

<sup>4)</sup> LA-4

<sup>5)</sup> L-2, L-4

# Accessories

## Protective roof and variable speed drives

**Protective roof**  
Variant code 005

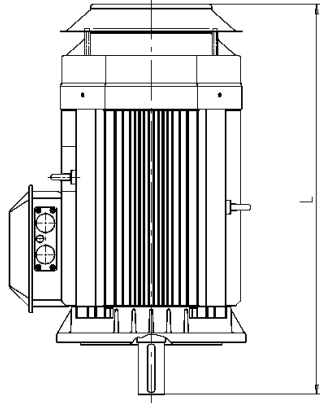

**Tacho**  
Variant codes; 472, 473, 572 and 573

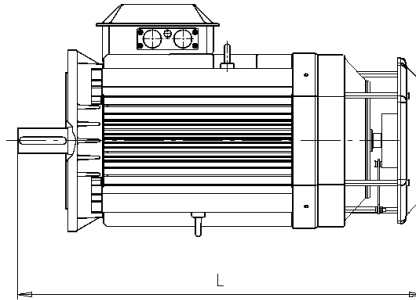

**Separate cooling with or without tacho**  
Variant codes; 183, 474, 476, 477, 189, 574, 576 and 577

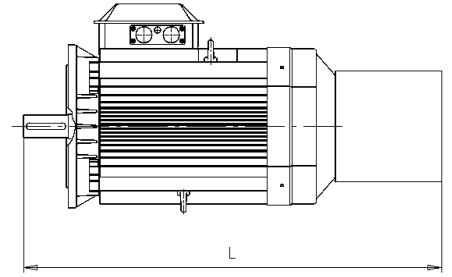

Variant codes; M3AA	005	183	189	472, 473 572, 573	474, 476 477, 574 576, 577
Motor size	L	L	L	L	L
112 <sup>1)</sup>	400	-	493.5	458.5	543.5
112 <sup>2)</sup>	428	-	538	487	588
132 <sup>3)</sup>	484	-	580.5	542	630.5
132 <sup>4)</sup>	522	-	640	580	690
160 <sup>5)</sup>	653.5	1015.5	870.5	697	1015.5
160 <sup>6)</sup>	694.5	1056.5	911.5	738	1056.5
180 <sup>7)</sup>	731	1097	952	774	1097
180 <sup>8)</sup>	751.5	1117.5	972.5	795	1117.5
200 <sup>9)</sup>	825	1234	1089	868	1234
200 <sup>10)</sup>	865	1274	1129	908	1274
225 <sup>11)</sup>	885	1295	1150	930	1295
225 <sup>12)</sup>	910	1320	1175	955	1320
225 <sup>13)</sup>	915	1325	1180	960	1325
225 <sup>14)</sup>	940	1350	1205	985	1350
250 <sup>15)</sup>	922	1346	1201	969	1346
250 <sup>16)</sup>	947	1371	1226	994	1371
280 <sup>17)</sup>	922	1346	1201	969	1346
280 <sup>18)</sup>	947	1371	1226	994	1371

<sup>1)</sup> M-6, M-8,

<sup>2)</sup> all 112 excl <sup>1)</sup>

<sup>3)</sup> SA-2, S-4, S-6, MA-6, MB-6, S-8, M-8, S-Two-speed

<sup>4)</sup> all 132 excl <sup>3)</sup>

<sup>5)</sup> M-2, MA-2, M-4, M-6, M-8, MA-8, L-2, L-4, L-6, MA-2/4, M-2/4, L-2/4, M-4/6, M-4/8, LB-2, LB-4

<sup>6)</sup> L-8, L-4/6, L-4/8, LB-6, LB-8.

<sup>7)</sup> M-2, M-4, L-6, L-8, M-2/4, M-4/6, M-4/8, LB-2

<sup>8)</sup> L-2/4, L-4/6, L-4/8, L-4, LB-4, LB-6, LB-8.

<sup>9)</sup> all 200 excl <sup>10)</sup>

<sup>10)</sup> MLD-2, MLC-4

<sup>11)</sup> SMB-2, SMC-2, SM\_-2/4

<sup>12)</sup> SMD-2,

<sup>13)</sup> all 225 excl <sup>11)</sup> <sup>12)</sup> <sup>14)</sup>

<sup>14)</sup> SMD-4

<sup>15)</sup> all 250 excl <sup>16)</sup>

<sup>16)</sup> SMC-2, SMC-4

<sup>17)</sup> all 280 excl <sup>18)</sup>

<sup>18)</sup> SMB-2, SMB-4

# General purpose aluminium motors in brief, basic design

Size		56	63	71	80	90	100	
Stator and feet	Material Paint colour shade Paint	Diecast aluminium alloy. Loose feet in sizes 71-100; feet integrated with stator in sizes 56-63. Munsell blue 8B 4.5/3.25 / NCS 4822 B05G Epoxy polyester powder paint , ≥ 30µm					Polyester powder paint, ≥ 30µm	
Bearing end shields	Material Paint colour shade Paint	Diecast aluminium alloy Munsell blue 8B 4.5/3.25 / NCS 4822 B05G Epoxy polyester powder paint , ≥ 30µm					Polyester powder paint, ≥ 30µm	
Bearings Single-speed motor	D-end N-end	6201-2Z/C3 6201-2Z/C3	6202-2Z/C3 6201-2Z/C3	6203-2Z/C3 6202-2Z/C3	6204-2Z/C3 6203-2Z/C3	6205-2Z/C3 6204-2Z/C3	6306-2Z/C3 6205-2Z/C3	
Bearings Two-speed motor	D-end N-end	6201-2Z/C3 6201-2Z/C3	6202-2Z/C3 6201-2Z/C3	6203-2Z/C3 6202-2Z/C3	6204-2Z/C3 6203-2Z/C3	6205-2Z/C3 6204-2Z/C3	6306-2Z/C3 6205-2Z/C3	
Axially-locked bearings	Inner bearing cover	Spring washer at the N-end.					D-end	
Bearing seals	D-end N-end	V-ring Labyrinth seal.						
Lubrication		Permanently lubricated bearings. Grease for bearing temperatures -40 to +160°C.						
Terminal box	Material Surface treatment Screws	Diecast aluminium alloy. Similar to stator. Steel 5G. Chromated.						
Connections	Knock-out openings Max Cu-area mm <sup>2</sup> Terminal box	1 x M16 x Pg11 2.5 Screw terminal, 6 terminals		2 x M20 x Pg16 4		4 x M25 6		
Fan	Material	Polypropylene. Reinforced with 20% glass fibre.						
Fan cover	Material	Steel.						
Stator winding	Material Impregnation Insulation class	Copper. Polyester varnish. Tropicalised. Insulation class F. Temperature rise class B, unless otherwise stated.						
Stator winding temperature sensors		Optional.						
Rotor winding	Material	Diecast aluminium.						
Balancing method		Half key balancing.						
Key way		Closed keyway						
Enclosure		IP 55.						
Cooling method		IC 411.						
Drain holes		Standard.						

2

Size	M2AA	112	132	160	180	200	225	250	
Stator	Material	Diecast aluminium alloy.					Extruded aluminium alloy.		
	Paint colour shade Paint	Munsell blue 8B 4.5/3.25 / NCS 4822 B05G Polyester powderpaint, $\geq 50\mu\text{m}$							
Feet	Material	Aluminium alloy, integrated with stator.			Cast iron bolted to the stator.				
Bearing end shields	Material	Diecast aluminium alloy			Flanged bearing end shields cast iron, others diecast aluminium. 280 N-end shields cast iron in 2-pole motors.				
	Paint colour shade Paint	Munsell blue 8B 4.5/3.25 / NCS 4822 B05G Polyester powderpaint, $\geq 50\mu\text{m}$							
Bearings Single-speed motor	D-end	6206-2Z/C3	6208-2Z/C3	6309-2Z/C3	6310-2Z/C3	6312/C3	6313/C3	6315/C3	
	N-end	6205-2Z/C3	6206-2Z/C3	6209-2Z/C3	6209-2Z/C3	6209-2Z/C3	6210/C3	6212/C3	
Bearings Two-speed motor	D-end	NA							
	N-end	NA							
Axially-locked bearings	Inner bearing cover	D-end <sup>1)</sup>		D-end					
		<sup>1)</sup> Foot motor. A spring washer at the N-end presses the motor towards the D-end. Flange motor. Inner bearing cover and spring-washer at the N-end.							
Bearing seals	D-end	V-ring					Outer and inner V-rings.		
	N-end	Labyrinth seal.					Outer and inner V-rings.		
Lubrication		Permanently lubricated shielded bearings. Grease temperature range -40 to +160°C.					Valve lubrication. Grease temp. range -40 to 150°C.		
Terminal box	Material	Diecast aluminium alloy, base integrated with stator.						Deep-drawn steel sheet, bolted to stator.	
	Surface treatment	Similar to stator.						Phosphated. Polyester paint.	
	Screws	Steel 5G. Galvanised.							
Connections	Knock-out openings Flange-openings	4 x (M25 + M20)			2 x (2 x M40 + M16)			2 x FL13, 2 x M40 2 x FL 21, 2 x M63 (voltage code S)	
	Screws Max Cu-area mm <sup>2</sup>	M5 10		M6 35		M10 70			
Terminal box		Cable lugs, 6 terminals							
Fan	Material	Polypropylene. Reinforced with 20% glass fibre.							
Fan cover	Material	Polypropylene.			Steel sheet. Also two-speed sizes 112 and 132 M.				
	Surface treatment	Phosphated. Polyester paint.							
Stator winding	Material	Copper.							
	Impregnation Insulation class	Polyester varnish. Tropicalised. Insulation class F. Temperature rise class B, unless otherwise stated.							
Stator winding temperature sensors		Optional.					PTC thermistors, 150°C, 3 in series.		
Rotor winding	Material	Diecast aluminium.							
Balancing method		Half key balancing.							
Key way		Closed keyway							
Enclosure		IP 55.							
Cooling method		IC 411.							
Drain holes		Drain holes with closable plastic plugs, open on delivery.							

Size	M3AA	112	132	160	180	200	225	250	280	
Stator	Material	Diecast aluminium alloy.				Extruded aluminium alloy.				
	Paint colour shade Paint	Munsell blue 8B 4.5/3.25 / NCS 4822 B05G Polyester powderpaint, ≥ 50µm								
Feet	Material	Aluminium alloy, integrated with stator.				Aluminium <sup>1)</sup> alloy, bolted to the stator. <sup>1)</sup> 250-2, cast iron			Cast iron	
Bearing end shields	Material	Diecast aluminium alloy			Flanged bearing end shields cast iron, others diecast aluminium.				Cast iron	
	Paint colour shade Paint	Munsell blue 8B 4.5/3.25 / NCS 4822 B05G Polyester powderpaint, ≥ 50µm								
Bearings Single-speed motor	D-end	6206-2Z/C3	6208-2Z/C3	6309-2Z/C3	6310-2Z/C3	6312/C3	6313/C3	6315/C3	6316/C3 <sup>1)</sup>	
	N-end <sup>2)</sup> N-end <sup>3)</sup>	6205-2Z/C3 6206-2Z/C3	6206-2Z/C3 6208-2Z/C3	6209-2Z/C3	6209-2Z/C3	6210/C3	6212/C3	6213/C3	6213/C3	
		<sup>1)</sup> 6315/C3 for 2-pole motors <sup>2)</sup> M3AA 112: M-6, M-8, M3AA 132: SA-2, S-4, S-6, MA-6, MB-6, S-8 and M-8. <sup>3)</sup> All motors sizes 112-132 not included in <sup>2)</sup> .								
Bearings Two-speed motor	D-end	6206-2Z/C3	6208-2Z/C3	6309-2Z/C3	6310-2Z/C3	6312/C3	6313/C3	6315/C3	NA	
	N-end <sup>1)</sup> N-end <sup>2)</sup>	6206-2Z/C3 6205-2Z/C3	6206-2Z/C3 6206-2Z/C3	6209-2Z/C3	6209-2Z/C3	6210/C3	6212/C3	6213/C3		
		<sup>1)</sup> M3AA 112, M3AA 132M.			<sup>2)</sup> M3AA 132S					
Axially-locked bearings	Inner bearing cover	D-end <sup>1)</sup>		D-end						
		<sup>1)</sup> Foot motor. A spring washer at the N-end presses the motor towards the D-end. Flange motor. Inner bearing cover and spring-washer at the N-end.								
Bearing seals	D-end	V-ring				Outer and inner V-rings.				
	N-end	Labyrinth seal. Except two-speed motors 112-132M, outer and inner V-rings.				Outer and inner V-rings.				
Lubrication		Permanently lubricated shielded bearings. Grease temperature range -40 to +160°C.				Valve lubrication. Grease temp. range -40 to 150°C.				
Terminal box	Material Surface treatment Screws	Diecast aluminium alloy, base integrated with stator. Similar to stator. Steel 5G. Galvanised.				Deep-drawn steel sheet, bolted to stator. Phosphated. Polyester paint.				
Connections	Knock-out openings Flange-openings	4 x(M25 + M20)		2 x (2 x M40 + M16)		2 x FL13, 2 x M40 2 x FL 21, 2 x M63 (voltage code S)			2 x FL21 2 x M63 1 x M16	
	Screws Max Cu-area mm <sup>2</sup>	M5 10		M6 35		M10 70				
Terminal box		Cable lugs, 6 terminals								
Fan	Material	Polypropylene. Reinforced with 20% glass fibre.								
Fan cover	Material	Polypropylene.			Steel sheet. Also two-speed sizes 112 and 132 M.					
	Surface treatment	Phosphated. Polyester paint.								
Stator winding	Material	Copper.								
	Impregnation Insulation class	Polyester varnish. Tropicalised. Insulation class F. Temperature rise class B, unless otherwise stated.								
Stator winding temperature sensors		Optional.				PTC thermistors, 150°C, 3 in series.				
Rotor winding	Material	Diecast aluminium.								
Balancing method		Half key balancing.								
Key way		Closed keyway								
Enclosure		IP 55.								
Cooling method		IC 411.								

# Drive<sup>IT</sup> General Purpose Steel Motors

Totally enclosed squirrel cage three phase low voltage motors,  
Sizes 280 - 400, 75 to 630 kW

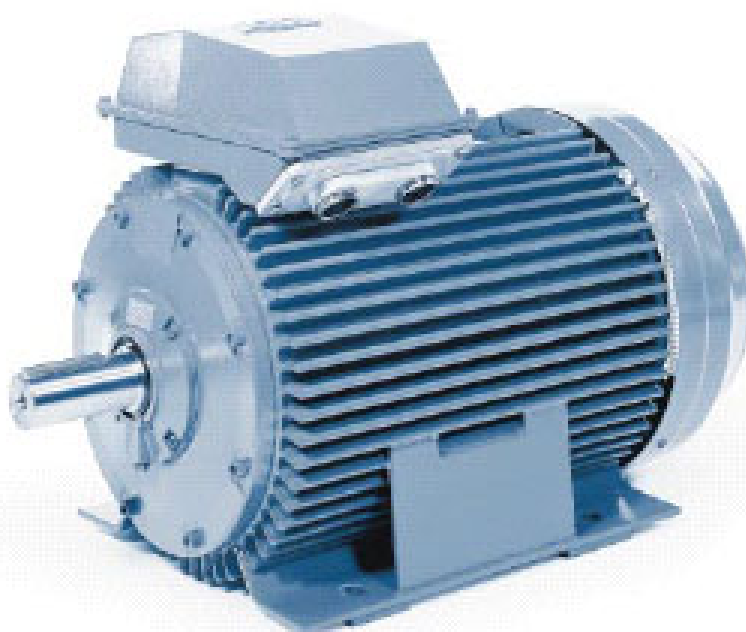

3

<b>Mechanical design.....</b>	<b>80</b>
<b>Ordering information.....</b>	<b>87</b>
<b>Technical data.....</b>	<b>88</b>
<b>Variant codes.....</b>	<b>93</b>
<b>Dimension drawings.....</b>	<b>96</b>
<b>Rating plates.....</b>	<b>106</b>
<b>Steel motors in brief.....</b>	<b>109</b>

# Mechanical design

## Stator

The stator frame is made of profile-pressed sheet steel, giving the motor high mechanical strength, low weight and a good surface finish. The stator core is welded into the stator frame and contributes to its excellent mechanical properties.

Feet and lifting eyes are welded to the stator frame. The terminal box and end shields are of cast iron.

## Drain holes

Motors that will be operated in very humid or wet environments, and especially under intermittent duty, should be provided with drain holes. The appropriate IM designation, such as IM V3 (IM 3031), is specified, on the basis of the method of motor mounting.

M2CA motors are fitted with drain holes and plugs. The

plugs are open on delivery. Check that the drain holes and grease outlet face downwards, when mounting designation differs from standard horizontal mounting.

In the case of vertical mounting, the upper plug must be hammered home completely. In very dusty environments the drain hole plug should be knocked in.

3

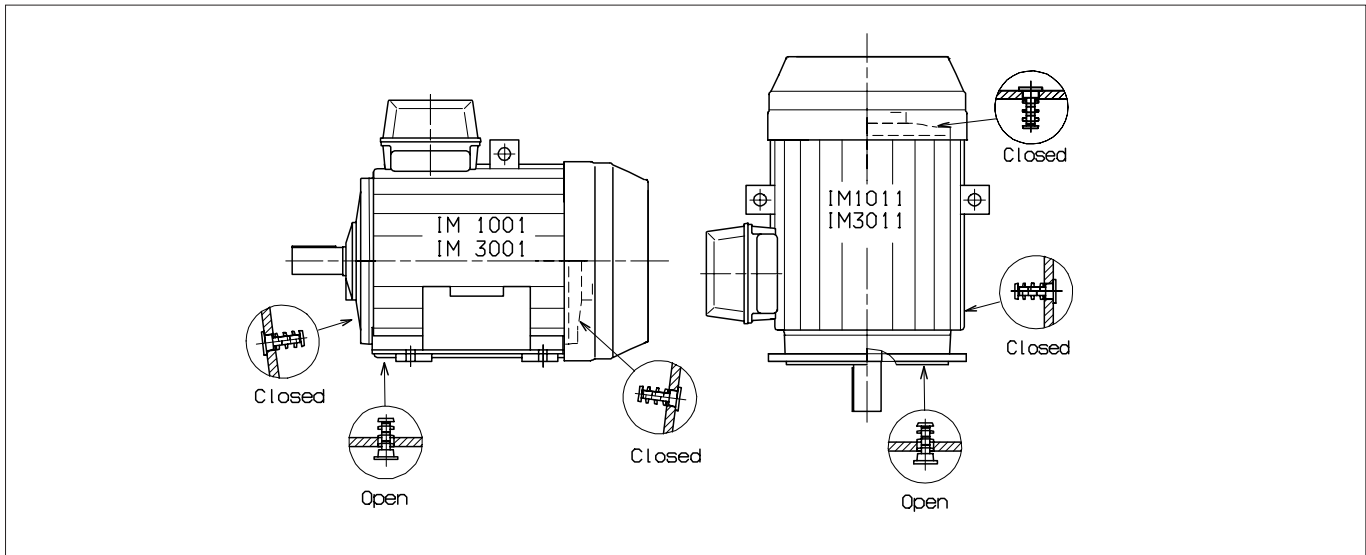

## Terminal box

Terminal boxes are mounted either on the top of the motor, or on either side of the motor, see ordering information.

In basic version the terminal box can be rotated  $2 \times 180^\circ$  to allow cable entry from either side of the motor, as option the terminal box can be turned  $4 \times 90^\circ$ .

Degree of protection of standard terminal box is IP 55.

The terminal box is equipped with cable glands or cable boxes as standard, and terminations are suitable for Cu- and Al-cables. Cables are connected to the terminals by cable lugs which are not included with the motor.

To enable us to supply suitable terminations for the motor please state cable type, quantity and size when ordering. Non-standard design of terminal boxes; e.g. size, degree of protection, are available as options.

Please see variant codes for options and dimension drawings of terminal boxes.



# Co-ordination of terminal boxes and cable entries

If no ordering information on the cable is given, it is assumed to be p.v.c. -insulated type and termination parts are supplied according to the table below and on next page.

Deviations from standard design according to the following tables are available on request.

## M2CA 280-400 motors with top-mounted terminal box Standard cable entries and cable boxes

Voltage 220 - 690 V, 50 Hz

Motor size M2CA	Ter- minal box	Flange or adapter	Cable box or cable gland	Gland thread	Cable diameter	Max. connection cable area mm <sup>2</sup>	Terminal bolt size	Voltage/ freq. code
<b>3000 r/min (2 poles)</b>								
280	122/4	3GZF 294730-749	2x 3GZF 294730-613	2x M63x1.5	2x Ø32-49	2x150	M12	
315 S_,M_,LA,LB	142/4	3GZF 294730-753	2x 3GZF 294730-613	2x M63x1.5	2x Ø32-49	2x240	M12	
315 LC	162/4	3GZF 294730-944	3GZF 294730-301		2x Ø48-60	4x240	M12	
355 SA	142/4	3GZF 294730-753	2x 3GZF 294730-613	2x M63x1.5	2x Ø32-49	2x240	M12	
355 M_	162/4	3GZF 294730-944	3GZF 294730-301		2x Ø48-60	4x240	M12	D
	142/4	-	3GZF 294730-301		2x Ø48-60	2x240	M12	E
355 L_	162/4	3GZF 294730-944	3GZF 294730-301		2x Ø48-60	4x240	M12	
400 M_	162/4	3GZF 294730-944	3GZF 294730-501		2x Ø60-80	4x240	M12	
400 LK_	162/9	3GZF 294730-944	3GZF 294730-501		2x Ø60-80	4x240	M12	
<b>1500 r/min (4 poles)</b>								
280	122/4	3GZF 294730-749	2x 3GZF 294730-613	2x M63x1.5	2x Ø32-49	2x150	M12	
315 S_,M_,LA,LB	142/4	3GZF 294730-753	2x 3GZF 294730-613	2x M63x1.5	2x Ø32-49	2x240	M12	
315 LC	162/4	3GZF 294730-944	3GZF 294730-301		2x Ø48-60	4x240	M12	
355 SA	142/4	3GZF 294730-753	2x 3GZF 294730-613	2x M63x1.5	2x Ø32-49	2x240	M12	
355 M_	162/4	3GZF 294730-944	3GZF 294730-301		2x Ø48-60	4x240	M12	D
	142/4	-	3GZF 294730-301		2x Ø48-60	2x240	M12	E
355 LA, LB	162/4	3GZF 294730-944	3GZF 294730-301		2x Ø48-60	4x240	M12	
355 LKD	162/4	3GZF 294730-944	3GZF 294730-501		2x Ø60-80	4x240	M12	
400 M_	162/4	3GZF 294730-944	3GZF 294730-501		2x Ø60-80	4x240	M12	
400 LKA	162/9	3GZF 294730-944	3GZF 294730-501		2x Ø60-80	4x240	M12	D
	162/4	3GZF 294730-944	3GZF 294730-501		2x Ø60-80	4x240	M12	E
400 LKB, LKC	162/9	3GZF 294730-944	3GZF 294730-501		2x Ø60-80	4x240	M12	
<b>1000 r/min (6 poles)</b>								
280	122/4	3GZF 294730-749	2x 3GZF 294730-613	2x M63x1.5	2x Ø32-49	2x150	M12	
315 S_,M_,LA,LB	142/4	3GZF 294730-753	2x 3GZF 294730-613	2x M63x1.5	2x Ø32-49	2x240	M12	
355 SA,SB	142/4	3GZF 294730-753	2x 3GZF 294730-613	2x M63x1.5	2x Ø32-49	2x240	M12	
355 MA	142/4	-	3GZF 294730-301		2x Ø48-60	2x240	M12	
355 MB	162/4	3GZF 294730-944	3GZF 294730-301		2x Ø48-60	4x240	M12	D
	142/4	-	3GZF 294730-301		2x Ø48-60	2x240	M12	E
355 LKD	162/4	3GZF 294730-944	3GZF 294730-301		2x Ø48-60	4x240	M12	
400 MLA	162/4	3GZF 294730-944	3GZF 294730-301		2x Ø60-80	4x240	M12	D
400 MLB	162/4	-	3GZF 294730-501		2x Ø48-60	2x240	M12	E
400 LK_	162/9	3GZF 294730-944	3GZF 294730-501		2x Ø60-80	4x240	M12	D
400 LK_	162/4	3GZF 294730-944	3GZF 294730-501		2x Ø60-80	4x240	M12	E
<b>750 r/min (8 poles)</b>								
280	122/4	3GZF 294730-749	2x 3GZF 294730-613	2x M63x1.5	2x Ø32-49	2x150	M12	
315	142/4	3GZF 294730-753	2x 3GZF 294730-613	2x M63x1.5	2x Ø32-49	2x240	M12	
355 SA, SB	142/4	3GZF 294730-753	2x 3GZF 294730-613	2x M63x1.5	2x Ø32-49	2x240	M12	
355 MA	142/4	-	3GZF 294730-301		2x Ø48-60	2x240	M12	
355 MB	142/4	-	3GZF 294730-301		2x Ø48-60	4x240	M12	D
355 MB	142/4	-	3GZF 294730-301		2x Ø48-60	2x240	M12	E
355 LKD	162/4	-	3GZF 294730-301		2x Ø48-60	4x240	M12	
400 MLA	162/4	3GZF 294730-944	3GZF 294730-301		2x Ø48-60	4x240	M12	D
	142/4	-	3GZF 294730-301		2x Ø48-60	2x240	M12	E
400 LKA	162/4	3GZF 294730-944	3GZF 294730-501		2x Ø60-80	4x240	M12	

Voltage/frequency codes:

D - 380-420 VΔ 50 Hz, 660-690 VY 50 Hz, 440-480 VΔ 60 Hz

E - 500 VΔ 50 Hz, 575 VΔ 60 Hz

Examples:

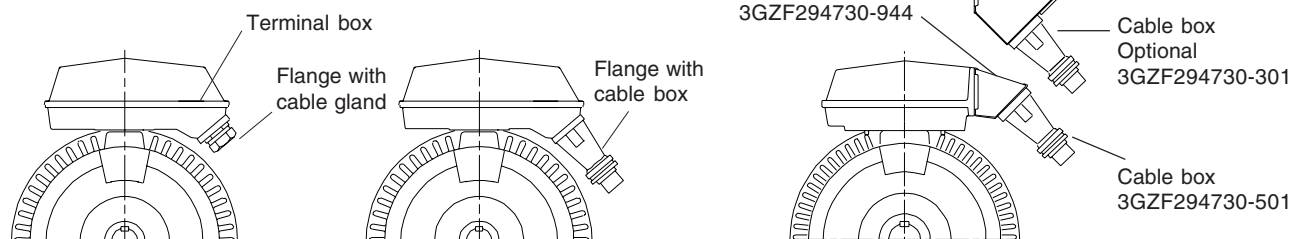

# M2CA motors with side-mounted terminal box:

## Standard cable entries and cable boxes

Voltage 220 - 690 V, 50 Hz

Motor size	Terminal box	Flange or adapter	Cable box or cable gland	Gland thread	Cable diameter	Max. connection cable area mm <sup>2</sup>	Terminal bolt size	Voltage/freq. code
<b>3000 r/min (2 poles)</b>								
280	122/5	3GZF 294730-749	2x 3GZF 294730-613	2x M63x1.5	2x Ø32-49	2x150	M12	
315 S_,M_,LA,LB	142/6	3GZF 294730-753	2x 3GZF 294730-613	2x M63x1.5	2x Ø32-49	2x240	M12	
315 LC	162/7	3GZF 294730-759	3GZF 294730-301		2x Ø48-60	4x240	M12	
355 SA	142/6	3GZF 294730-753	2x 3GZF 294730-613	2x M63x1.5	2x Ø32-49	2x240	M12	
355 M_	162/7	3GZF 294730-759	3GZF 294730-301		2x Ø48-60	4x240	M12	D
	142/6	-	3GZF 294730-301		2x Ø48-60	2x240	M12	E
355 L_	162/7	3GZF 294730-759	3GZF 294730-301		2x Ø48-60	4x240	M12	
400 M_	162/7	3GZF 294730-759	3GZF 294703-501		2x Ø60-80	4x240	M12	
400 LK_	162/7	3GZF 294730-759	3GZF 294703-501		2x Ø60-80	4x240	M12	
<b>1500 r/min (4 poles)</b>								
280	122/5	3GZF 294730-749	2x 3GZF 294730-613	2x M63x1.5	2x Ø32-49	2x150	M12	
315 S_,M_,LA,LB	142/6	3GZF 294730-753	2x 3GZF 294730-613	2x M63x1.5	2x Ø32-49	2x240	M12	
315 LC	162/7	3GZF 294730-759	3GZF 294730-301		2x Ø48-60	4x240	M12	
355 SA	142/6	3GZF 294730-753	2x 3GZF 294730-613	2x M63x1.5	2x Ø32-49	2x240	M12	
355 M_	162/7	3GZF 294730-759	3GZF 294730-301		2x Ø48-60	4x240	M12	D
	142/6	-	3GZF 294730-301		2x Ø48-60	2x240	M12	E
355 LA, LB	162/7	3GZF 294730-759	3GZF 294730-301		2x Ø48-60	4x240	M12	
355 LKD	162/7	3GZF 294730-759	3GZF 294703-501		2x Ø60-80	4x240	M12	
400 M_	162/7	3GZF 294730-759	3GZF 294703-501		2x Ø60-80	4x240	M12	
400 LKA	162/7	3GZF 294730-759	3GZF 294703-501		2x Ø60-80	4x240	M12	D
	162/7	3GZF 294730-759	3GZF 294703-501		2x Ø60-80	4x240	M12	E
400 LKB, LKC	162/7	3GZF 294730-759	3GZF 294703-501		2x Ø60-80	4x240	M12	
<b>1000 r/min (6 poles)</b>								
280	122/5	3GZF 294730-749	2x 3GZF 294730-613	2x M63x1.5	2x Ø32-49	2x150	M12	
315 S_,M_,LA,LB	142/6	3GZF 294730-753	2x 3GZF 294730-613	2x M63x1.5	2x Ø32-49	2x240	M12	
355 SA,SB	142/6	3GZF 294730-753	2x 3GZF 294730-613	2x M63x1.5	2x Ø32-49	2x240	M12	
355 MA	142/6	-	3GZF 294730-301		2x Ø48-60	2x240	M12	
355 MB	162/7	3GZF 294730-759	3GZF 294730-301		2x Ø48-60	4x240	M12	D
	142/6	-	3GZF 294730-301		2x Ø48-60	2x240	M12	E
355 LKD	162/7	3GZF 294730-759	3GZF 294730-301		2x Ø48-60	4x240	M12	
400 ML_	162/7	3GZF 294730-759	3GZF 294703-501		2x Ø60-80	4x240	M12	D
	142/6	-	3GZF 294730-301		2x Ø48-60	2x240	M12	E
400 LK_	162/7	3GZF 294730-759	3GZF 294703-501		2x Ø60-80	4x240	M12	
<b>750 r/min (8 poles)</b>								
280	122/5	3GZF 294730-749	2x 3GZF 294730-613	2x M63x1.5	2x Ø32-49	2x150	M12	
315	142/6	3GZF 294730-753	2x 3GZF 294730-613	2x M63x1.5	2x Ø32-49	2x240	M12	
355 SA, SB	142/6	3GZF 294730-753	2x 3GZF 294730-613	2x M63x1.5	2x Ø32-49	2x240	M12	
355 MA	142/6	-	3GZF 294730-301		2x Ø48-60	2x240	M12	
355 MB	162/7	3GZF 294730-759	3GZF 294730-301		2x Ø48-60	4x240	M12	D
	142/6	-	3GZF 294730-301		2x Ø48-60	2x240	M12	E
355 LKD	162/7	3GZF 294730-759	3GZF 294730-301		2x Ø48-60	4x240	M12	D
400 MLA	162/7	3GZF 294730-759	3GZF 294730-301		2x Ø48-60	4x240	M12	D
	142/6	-	3GZF 294730-301		2x Ø48-60	2x240	M12	E
400 LK_	162/7	3GZF 294730-759	3GZF 294703-501		2x Ø60-80	4x240	M12	

Voltage/frequency codes:

D - 380-420 V Δ 50 Hz, 660-690 VY 50 Hz, 440-480 V Δ 60 Hz

E - 500 V Δ 50 Hz, 575 V Δ 60 Hz

Examples:

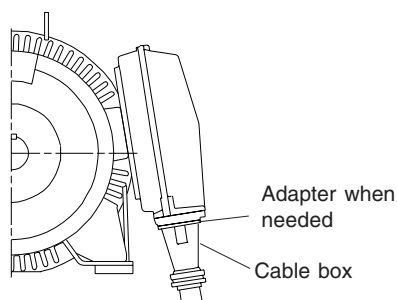
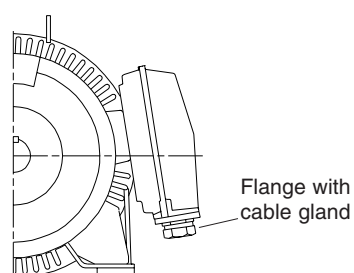

Auxiliary devices (view from N-end):

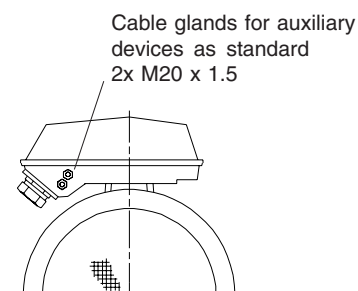

## Alternatives for cable entries and cable boxes

The tables on previous pages show the standard terminal boxes and termination parts that are delivered when no information on the cable is given.

The table below shows the different alternatives available for cable boxes and cable entries. Other types on request.

Motor size	Terminal box on top	Terminal box on side	Opening type	Max. rated current A ( $\Delta/Y$ -conn.)	Max. size of conductor mm <sup>2</sup>	Cable gland	Cable box	Blank plate
280	122/4	122/5	C (FL 21)	360/210	2x150	2xPg29...42	1xØ36...52/Ø48...60	MKLN 20
315 S_, M_, LA, LB	142/4	142/6	D (FL33)	640/370	2x240	1xPg36...42 2xPg36...48	1xØ36...52/Ø48...60 2xØ48...60/Ø50...68 2xØ68...80	MKLN 30
315 LC 355, 400	142/4	142/6	D (FL33)	640/370	2x240	1xPg36...42 2xPg36...48	1xØ36...52/Ø48...60 2xØ48...60/Ø50...68 2xØ68...80	MKLN 30
	162/4	162/7	E-D <sup>1)</sup>	950/550	4x240	2xPg36...48 1xPg36...42	1xØ36...52/Ø48...60 2xØ48...60/Ø50...68 2xØ68...80	
	162/4	162/7	E-D <sup>1)</sup>	1300/750	4x240	2xPg36...48 1xPg36...42	1xØ36...52/Ø48...60 2xØ48...60/Ø50...68 2xØ68...80	
	162/4	162/7	E-2D <sup>1)</sup>	1300/750	4x240	2x2xPg36...48 2x1xPg36...42	2x1xØ36...52/Ø48...60 2x2xØ48...60/Ø50...68 2x2xØ68.m.80	

<sup>1)</sup> Terminal box type 162 is used with a combination of one E-opening and one or two D-openings, see pictures below and drawing pages.

**Terminal box 162 with adapting flange 3GZF 294730-501 (E-D) or optional 3GZF 294730-301 (E-2D) :**

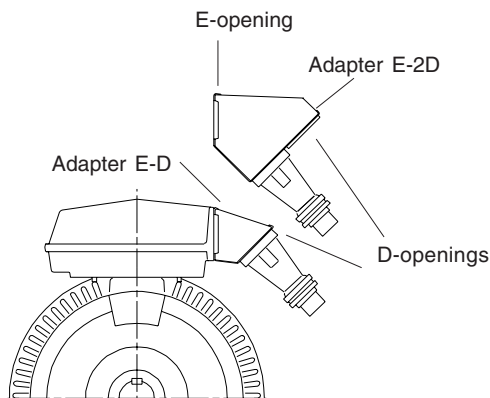

**Terminal box 162 with adapting flange:**

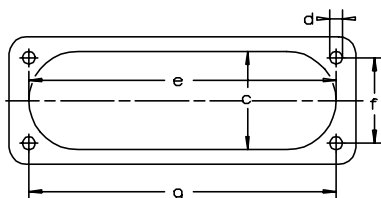
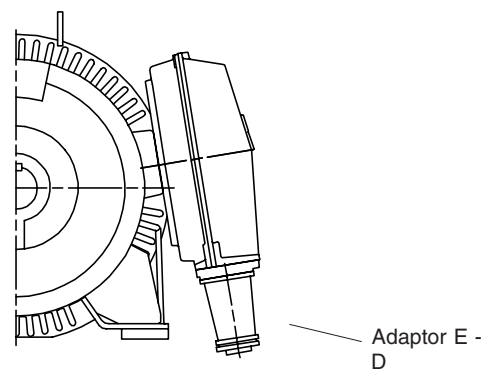

Opening	c	e	f	g	d
C (FL 21)	62	193	62	193	M8
D (FL 33)	100	300	80	292	M10
E (FL 40)	115	370	100	360	M12

# Bearings

The motors are normally fitted with single-row deep groove ball bearings as listed in the table below. The complete ball bearing designation is stated on the rating plate.

If the bearing at the D-end is replaced with a roller bearing (NU- or NJ-), higher radial forces can be handled. Roller bearings are suitable for belt drive applications.

When there are high axial forces, angular contact ball bearings should be used. This option is available on request. When a motor with angular contact ball bearings is ordered, the method of mounting and direction and magnitude of the axial force must be specified. For special bearings, please see the variant codes.

## Bearing types

Motor size	Number of poles	Standard design Deep groove ball bearings		Alternative designs Roller bearings variant code 037
		D-end	N-end	D-end
280	2	6316/C4	6316/C4	1)
	4-12	6316/C3	6316/C3	NU 316/C3
315	2	6316/C4	6316/C4	1)
	4-12	6319/C3	6316/C3	NU319/C3
355	2	6316M/C4	6316M/C4	1)
	4-12	6322/C3	6319/C3	NU 322/C3
400	2	6317M/C4	6317M/C4	1)
	4-12	6322/C3	6319/C3	NU 322/C3

1) On request

## Axially-locked bearings

The outer bearing ring at the D-end is axially locked with an inner bearing cover. The inner ring is locked by tight tolerance to the shaft.

All motors are equipped as standard with an axially-locked bearing at the D-end.

## Transport locking

Motors that have roller bearings or an angular contact ball bearing are fitted with a transport lock before despatch to prevent damage to the bearings during transport. In case of transport locked bearing, the motor is provided with a warning sign.

Locking may also be fitted in other cases where transport conditions are suspected of being potentially damaging.

# Bearing seals

M2CA motors have, as standard, V-rings at both ends. The size and type of suitable seals are in accordance with the table below:

Motor size	Number of poles	d <sub>1</sub>	d <sub>2</sub>	B <sub>1</sub>	b	Standard design Axial seal		Alternative design Radial seal (DIN 3760) Variant code 072
						D-end	N-end	
280	2	80	100	13.5	10	VS 80	VS 80	80x100x10 <sup>1)</sup>
	4-12	80	100	13.5	10	VS 80	VS 80	80x100x10
315	2	80	100	13.5	10	VS 80	VS 80	80x100x10 <sup>1)</sup>
	4-12	95	120	13.5	12	VS 95	VS 80	95x120x12
355	2	95	120	13.5	12	VS 80	VS 80	80x100x10 <sup>1)</sup>
	4-12	110	140	15.5	12	VS 110	VS 95	110x140x12 <sup>1)</sup>
400	2	95	120	13.5	12	VS 85	VS 85	85x110x12 <sup>1)</sup>
	4-12	110	140	15.5	12	VS 110	VS 95	110x140x12 <sup>1)</sup>

<sup>1)</sup> Viton-seal

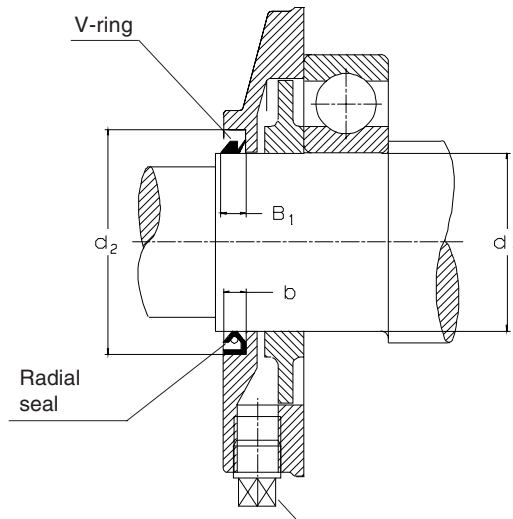

Sealing plugs are not used in standard flange-mounted motors.

## Bearing life

The nominal life L<sub>10</sub> of a bearing is defined according to ISO as the number of operating hours achieved or exceeded by 90% of identical bearings in a large test series under certain specified conditions. 50% of the bearings achieve at least five times this figure.

The calculated bearing life L<sub>10</sub> for power transmission by means of a coupling (horizontal machine):  
Motor sizes M2CA 280 to 400 ≥ 200.000 hours.

## Pulley diameter

When the desired bearing life has been determined, the minimum permissible pulley diameter can be calculated using F<sub>R</sub>, as follows:

$$D = \frac{1.9 \cdot 10^7 \cdot K \cdot P}{n \cdot F_R}$$

where:

D = diameter of pulley, mm

P = power requirement, kW

n = motor speed, r/min

K = belt tension factor, dependent on belt type and type of duty. A common value for V-belts is 2.5.

F<sub>R</sub> = permissible radial force

# Permissible loading on shaft

The table below gives the permissible radial and axial forces in Newtons, assuming the occurrence of only radial or axial force. In case of simultaneous radial and axial forces, information can be supplied on request. The values are based on normal conditions at 50 Hz and calculated bearing lives of 40,000 h.

Motors are B3 version with force directed sideways. In some cases the strength of the shaft affects the permissible forces.

At 60 Hz the values must be reduced by 10 %. For two-speed motors, the values must be based on the higher speed. When there are high axial forces, angular contact ball bearings should be used.

Permissible loads of simultaneous radial and axial forces will be supplied on request.

## Permissible radial and axial force for a bearing life of 40,000 hours

Motor size	Number of poles	Length of shaft extension E (mm)	Permissible radial force:				Permissible axial force:		
			Ball bearing at point of application:		Roller bearing at point of application:		Horizontal mounting	Vertical mounting with shaft extension downwards	
			$X_0$	$X_{max}$	$X_0$	$X_{max}$	Outwards	Upwards	Downwards
280	2	140	5800	4800	–	–	3700	7050	2600
	4	140	7300	6100	20000	10500	4000	7650	2800
	6	140	8300	6800	22500	10500	4900	8800	3400
	8	140	9200	7500	24700	10500	5700	9750	4100
315	2	140	5800	4900	–	–	3600	7400	1800
	4	170	8900	7300	26500	10500	4900	9200	2800
	6	170	10300	8500	29800	10500	6150	10700	3300
	8	170	11300	9300	32500	11000	6900	11800	4300
355	2	140	5800	5100	–	–	2400	<sup>1)</sup>	<sup>1)</sup>
	4	210	12000	9800	36700	17500	3900	<sup>1)</sup>	<sup>1)</sup>
	6	210	13500	11300	41500	17000	5100	<sup>1)</sup>	<sup>1)</sup>
	8	210	15000	12500	45200	17500	6350	<sup>1)</sup>	<sup>1)</sup>
400	2	170	5800	5100	–	–	6700	<sup>1)</sup>	<sup>1)</sup>
	4	210	11800	10200	37300	16700	3450	<sup>1)</sup>	<sup>1)</sup>
	6	210	13600	11700	42000	13500	4750	<sup>1)</sup>	<sup>1)</sup>
	8	210	15100	12900	45700	16800	5700	<sup>1)</sup>	<sup>1)</sup>

<sup>1)</sup> On request

If the radial force is applied between points  $X_0$  and  $X_{max}$ , the permissible force  $F_R$  can be calculated from the following formula:

$$F_R = F_{X_0} - \frac{X}{E} (F_{X_0} - F_{X_{max}})$$

E = length of shaft extension in basic version

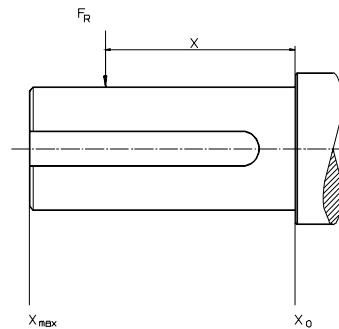

# Ordering information

## Sample order

When placing an order, please state the following minimum data in the order, as in the example.

The product code of the motor is composed in accordance with the following example.

Motor type	M2CA 315SMA
Pole number	4
Mounting arrangement (IM-code)	IM B3 (IM 1001)
Rated output	132 kW
Product code	3GCA312210-ADA
Variant codes if needed	

A	B	C	D,E,F, G						
<b>M2CA 315 SMA</b>			<b>3GCA 312 210 - ADA, 003 etc.</b>						
		1 - 4	5 - 6 7	8 - 10	11	12	13	14	

**A** Motor type  
**B** Motor size  
**C** Product code  
**D** Mounting arrangement code  
**E** Voltage/frequency code  
**F** Generation code  
**G** Variant code

## Explanation of the product code:

### Positions 1 to 4

**3GCA** = Totally enclosed fan cooled squirrel cage motor with steel stator frame

### Positions 5 and 6

IEC-size

**28** = 280

**35** = 355

**31** = 315

**40** = 400

### Position 7

Speed (Pole pairs)

**1** = 2 poles

**6** = 12 poles

**2** = 4 poles

**7** = > 12 poles

**3** = 6 poles

**8** = Two-speed motors

**4** = 8 poles

**9** = Multi-speed motors

**5** = 10 poles

### Position 8 to 10

Serial number

### Position 11

-(dash)

### Position 12

Mounting arrangement

**A** = Foot-mounted, top-mounted terminal box

**R** = Foot-mounted, terminal box RHS seen from D-end

**L** = Foot-mounted, terminal box LHS seen from D-end

**B** = Flange-mounted, large flange

**H** = Foot- and flange-mounted, top-mounted terminal box

**S** = Foot- and flange-mounted, terminal box RHS seen from D-end

**T** = Foot- and flange-mounted, terminal box LHS seen from D-end

### Position 13

Voltage and frequency code

See table below

### Position 14

Generation code = A

**The product code must be, if needed, followed by variant codes.**

## Code letters for supplementing the product code for voltage and frequency:

A	B	D	E	F	H
380 VY 50 Hz	380 VΔ 50 Hz	380-420 VΔ 50 Hz 660-690 VY 50 Hz 440-480 VΔ 60 Hz	500 VΔ 50 Hz 575 VΔ 60 Hz	500 VY 50 Hz 575 VY 60 Hz	415 VΔ 50 Hz
S	T	U	X		
220-240 VΔ 50 Hz 380-420 VY 50 Hz 440-480 VY 60 Hz	660 VΔ 50 Hz	690 VΔ 50 Hz	Other rated voltage, connection or frequency, max. 690 V		

# General purpose steel motors

## Technical data for totally enclosed squirrel cage three phase motors

IP 55 – IC 411 – Insulation class F, temperature rise class B

Output kW	Motor type	Product code	Speed r/min	Efficiency		Power factor cos φ	Current		Torque			
				Full load 100%	3/4 load 75%		$I_N$	$I_s$	$T_N$	$T_s$	$T_{max}$	
							A	$I_N$	Nm	$T_N$	$T_N$	
<b>3000 r/min = 2 poles</b>			<b>400 V 50 Hz</b>				<b>Basic design</b>					
75	M2CA 280 SA	3GCA 281 110-••A	2977	94.9	94.6	0.88	131	7.5	241	2.3	3.3	
90	M2CA 280 SMA	3GCA 281 210-••A	2975	95.1	94.9	0.9	152	7.6	289	2.3	2.9	
110	M2CA 315 SA	3GCA 311 110-••A	2982	95.1	94.4	0.86	194	7.6	352	2.0	3.0	
132	M2CA 315 SMA	3GCA 311 210-••A	2982	95.4	94.9	0.88	228	7.4	423	2.2	3.0	
160	M2CA 315 MB	3GCA 311 320-••A	2981	96.1	95.6	0.89	269	7.5	513	2.3	3.0	
200 <sup>3)</sup>	M2CA 315 LA	3GCA 311 510-••A	2978	96.3	95.9	0.9	334	7.8	641	2.6	3.0	
200	M2CA 355 SA	3GCA 351 110-••A	2977	95.5	95.1	0.92	330	6.6	641	1.3	2.8	
250	M2CA 355 MA	3GCA 351 310-••A	2980	96.1	95.7	0.92	410	6.6	801	1.3	3.0	
280	M2CA 355 MB	3GCA 351 320-••A	2978	96.1	95.9	0.92	470	5.7	897	1.1	2.7	
315	M2CA 355 LA	3GCA 351 510-••A	2980	96.6	96.4	0.93	510	7.7	1009	1.3	3.3	
355	M2CA 355 LB	3GCA 351 520-••A	2977	96.0	95.9	0.92	575	7.0	1138	1.0	3.1	
400 <sup>2)</sup>	M2CA 400 MLA	3GCA 401 410-••A	2982	96.6	96.5	0.92	655	7.6	1281	0.8	3.0	
450 <sup>1)2)</sup>	M2CA 400 MLB	3GCA 401 420-••A	2980	96.6	96.5	0.92	730	7.4	1442	0.8	3.0	
500 <sup>1)2)</sup>	M2CA 400 LKA	3GCA 401 510-••A	2984	96.6	96.5	0.91	815	7.2	1600	0.7	3.4	
560 <sup>1)2)</sup>	M2CA 400 LKB	3GCA 401 520-••A	2983	96.7	96.6	0.92	910	7.3	1792	0.7	3.4	
<b>3000 r/min = 2 poles</b>			<b>400 V 50 Hz</b>				<b>High-output design</b>					
110	M2CA 280 MB	3GCA 281 320-••A	2977	95.8	95.5	0.9	184	7.9	353	2.4	3.0	
132	M2CA 280 MC	3GCA 281 330-••A	2976	96.0	95.7	0.91	222	7.7	424	2.6	3.0	
160	M2CA 280 MD	3GCA 281 340-••A	2975	96.0	95.7	0.91	266	7.9	514	2.8	3.1	
250 <sup>3)</sup>	M2CA 315 LB	3GCA 311 520-••A	2980	96.5	96.2	0.9	420	8.1	801	2.8	2.9	
315 <sup>3)</sup>	M2CA 315 LC	3GCA 311 530-••A	2982	96.8	96.6	0.9	528	8.9	1009	3.4	3.1	
<b>1500 r/min = 4 poles</b>			<b>400 V 50 Hz</b>				<b>Basic design</b>					
75	M2CA 280 SA	3GCA 282 110-••A	1483	95.0	94.9	0.84	137	6.8	483	2.4	2.8	
90	M2CA 280 SMA	3GCA 282 210-••A	1484	95.2	95.1	0.85	163	7.1	579	2.7	2.9	
110	M2CA 315 SA	3GCA 312 110-••A	1487	95.4	95.1	0.85	198	6.9	706	2.1	2.8	
132	M2CA 315 SMA	3GCA 312 210-••A	1486	95.6	95.5	0.85	238	6.7	848	2.2	2.7	
160 <sup>3)</sup>	M2CA 315 MB	3GCA 312 320-••A	1486	96.0	95.9	0.86	282	7.2	1028	2.4	2.9	
200 <sup>3)</sup>	M2CA 315 LA	3GCA 312 510-••A	1486	96.2	96.2	0.86	351	7.2	1285	2.5	2.9	
200	M2CA 355 SA	3GCA 352 110-••A	1487	95.8	95.6	0.87	345	7.0	1284	2.1	2.7	
250	M2CA 355 MA	3GCA 352 310-••A	1487	96.5	96.4	0.87	430	7.2	1605	2.3	2.8	
315	M2CA 355 LA	3GCA 352 510-••A	1488	96.5	96.4	0.87	545	7.4	2021	2.4	2.8	
355	M2CA 355 LB	3GCA 352 520-••A	1489	96.5	96.4	0.88	605	7.2	2276	1.4	3.0	
400 <sup>2)</sup>	M2CA 355 LKD	3GCA 352 540-••A	1489	96.7	96.5	0.88	680	7.5	2565	1.5	3.0	
450	M2CA 400 MLA	3GCA 402 410-••A	1489	96.7	96.6	0.9	740	6.9	2886	1.2	2.8	
500	M2CA 400 MLB	3GCA 402 420-••A	1489	96.8	96.7	0.89	830	7.3	3206	1.3	2.9	
560	M2CA 400 LKA	3GCA 402 510-••A	1489	96.9	96.8	0.9	925	6.6	3591	1.1	2.6	
630 <sup>2)</sup>	M2CA 400 LKB	3GCA 402 520-••A	1489	96.9	96.8	0.87	1080	6.9	4040	1.2	2.8	
<b>1500 r/min = 4 poles</b>			<b>400 V 50 Hz</b>				<b>High-output design</b>					
110	M2CA 280 MB	3GCA 282 320-••A	1483	95.3	95.2	0.86	195	7.5	708	2.7	2.8	
132	M2CA 280 MC	3GCA 282 330-••A	1483	95.6	95.5	0.86	235	7.1	850	2.8	2.9	
160	M2CA 280 MD	3GCA 282 340-••A	1483	95.8	95.7	0.86	283	7.1	1030	2.8	3.1	
250	M2CA 315 LB	3GCA 312 520-••A	1487	96.1	96.0	0.85	445	7.4	1605	2.5	2.9	
315 <sup>3)</sup>	M2CA 315 LC	3GCA 312 530-••A	1487	96.4	96.2	0.85	560	7.8	2023	2.6	3.2	

<sup>1)</sup> On request.

<sup>2)</sup> Temperature rise acc. to class F.

<sup>3)</sup> Temperature rise acc. to class F by 380 V.

The two bullets in the product code indicate choice of mounting arrangement, voltage and frequency (see ordering information page).



# General purpose steel motors

## Technical data for totally enclosed squirrel cage three phase motors

IP 55 – IC 411 – Insulation class F, temperature rise class B

Output kW	Motor type	Speed r/min	Efficiency %	Power factor cos φ	Current I <sub>N</sub> A	Speed r/min	Efficiency %	Power factor cos φ	Current I <sub>N</sub> A	Moment of inertia J = ¼ GD <sup>2</sup> kgm <sup>2</sup>	Weight kg	Sound pressure level L <sub>p</sub> dB(A)
<b>3000 r/min = 2 poles</b>		<b>380 V 50 Hz</b>				<b>415 V 50 Hz</b>				<b>Basic design</b>		
75	M2CA 280 SA	2974	94.8	0.89	137	2980	94.8	0.87	127	0.8	480	77
90	M2CA 280 SMA	2970	95.1	0.9	159	2978	95.1	0.89	147	0.9	545	77
110	M2CA 315 SA	2980	95.1	0.87	202	2983		0.85	190	1.2	695	80
132	M2CA 315 SMA	2980	95.4	0.89	238	2983	95.7	0.87	222	1.4	770	80
160	M2CA 315 MB	2979	96.1	0.9	282	2982	96.1	0.89	262	1.7	840	80
200	M2CA 315 LA	2977	96.3	0.9	350	2981	96.3	0.9	321	2.1	975	80
200	M2CA 355 SA	2975	95.4	0.92	350	2979	95.5	0.91	325	3.2	1220	83
250	M2CA 355 MA	2978	96.0	0.92	430	2982	96.1	0.92	395	3.8	1320	83
280	M2CA 355 MB	2975	96.0	0.92	495	2980	96.1	0.92	450	3.8	1320	83
315	M2CA 355 LA	2976	96.5	0.93	540	2982	96.6	0.92	495	4.8	1530	83
355	M2CA 355 LB	2972	96.0	0.92	605	2974	96.1	0.92	550	4.8	1550	83
400 <sup>2)</sup>	M2CA 400 MLA	2980	96.5	0.92	680	2983	96.5	0.92	630	7.2	2300	85
450 <sup>1)2)</sup>	M2CA 400 MLB	2978	96.6	0.92	770	2982	96.6	0.92	700	7.2	2300	85
500 <sup>1)2)</sup>	M2CA 400 LKA	2982	96.6	0.92	850	2985	96.6	0.91	790	8.5	2700	85
560 <sup>1)2)</sup>	M2CA 400 LKB	2981	96.7	0.92	965	2984	96.8	0.91	885	8.5	2700	85
<b>3000 r/min = 2 poles</b>		<b>380 V 50 Hz</b>				<b>415 V 50 Hz</b>				<b>High-output design</b>		
110	M2CA 280 MB	2974	95.7	0.91	193	2979	95.8	0.9	179	1.15	580	77
132	M2CA 280 MC	2972	95.9	0.91	233	2978	96.0	0.9	213	1.4	755	77
160	M2CA 280 MD	2971	95.9	0.91	280	2977	96.0	0.9	255	1.55	810	77
250 <sup>3)</sup>	M2CA 315 LB	2977	96.4	0.9	442	2982	96.5	0.89	404	2.65	1230	80
315 <sup>3)</sup>	M2CA 315 LC	2979	96.8	0.9	550	2983	96.8	0.9	508	3.3	1410	80
<b>1500 r/min = 4 poles</b>		<b>380 V 50 Hz</b>				<b>415 V 50 Hz</b>				<b>Basic design</b>		
75	M2CA 280 SA	1481	94.8	0.86	142	1485	95.0	0.82	134	1.15	445	68
90	M2CA 280 SMA	1482	95.1	0.86	169	1486	95.2	0.83	159	1.4	490	68
110	M2CA 315 SA	1486	95.3	0.86	204	1488	95.3	0.83	198	2	675	71
132	M2CA 315 SMA	1485	95.5	0.86	245	1487	95.5	0.84	232	2.3	730	71
160 <sup>3)</sup>	M2CA 315 MB	1485	95.9	0.87	294	1487	96.0	0.85	277	2.9	850	71
200 <sup>3)</sup>	M2CA 315 LA	1484	96.1	0.87	365	1487	96.2	0.85	342	3.5	970	71
200	M2CA 355 SA	1485	95.7	0.87	360	1488	95.8	0.86	340	5.5	1220	80
250	M2CA 355 MA	1486	96.4	0.87	455	1488	96.5	0.86	420	6.5	1350	80
315	M2CA 355 LA	1486	96.4	0.87	570	1489	96.5	0.86	530	7.8	1550	80
355	M2CA 355 LB	1487	96.4	0.89	630	1490	96.5	0.87	590	7.8	1550	80
400 <sup>2)</sup>	M2CA 355 LKD	1487	96.6	0.89	710	1490	96.7	0.87	660	10	1900	85
450	M2CA 400 MLA	1487	96.6	0.9	770	1490	96.7	0.9	720	13	2400	85
500	M2CA 400 MLB	1488	96.7	0.9	870	1490	96.8	0.89	800	13	2400	85
560	M2CA 400 LKA	1487	96.8	0.91	965	1490	96.9	0.9	890	14	2700	85
630 <sup>2)</sup>	M2CA 400 LKB	1488	96.8	0.88	1125	1490	96.9	0.87	1040	15	2800	85
<b>1500 r/min = 4 poles</b>		<b>380 V 50 Hz</b>				<b>415 V 50 Hz</b>				<b>High-output design</b>		
110	M2CA 280 MB	1481	95.2	0.87	204	1486	95.5	0.84	193	1.7	550	68
132	M2CA 280 MC	1481	95.4	0.87	245	1485	95.7	0.85	227	2.3	775	70
160	M2CA 280 MD	1482	95.6	0.87	295	1485	95.8	0.85	276	2.5	820	70
250	M2CA 315 LB	1485	95.9	0.86	463	1488	96.2	0.84	434	4.4	1200	78
315 <sup>3)</sup>	M2CA 315 LC	1485	96.1	0.86	582	1489	96.4	0.84	548	5.5	1380	78

# General purpose steel motors

## Technical data for totally enclosed squirrel cage three phase motors

IP 55 – IC 411 – Insulation class F, temperature rise class B

Output kW	Motor type	Product code	Speed r/min	Efficiency		Power factor cos $\phi$	Current		Torque			
				Full load 100%	3/4 load 75%		$I_N$	$I_s$	$T_N$	$T_s$	$T_{max}$	
							A	$I_N$	Nm	$T_N$	$T_N$	$T_N$
<b>1000 r/min = 6 poles</b>			<b>400 V 50 Hz</b>				<b>Basic design</b>					
45	M2CA 280 SA	3GCA 283 110-A	990	94.1	94.0	0.82	85	6.6	434	2.5	2.5	
55	M2CA 280 SMA	3GCA 283 210-A	989	94.4	94.3	0.83	102	6.6	531	2.5	2.5	
75	M2CA 315 SA	3GCA 313 110-A	992	94.9	94.7	0.8	143	7.1	722	2.3	2.7	
90	M2CA 315 SMA	3GCA 313 210-A	991	95.3	95.2	0.83	165	7.1	867	2.3	2.7	
110	M2CA 315 MB	3GCA 313 320-A	991	95.3	95.1	0.83	201	7.3	1060	2.5	2.8	
132	M2CA 315 LA	3GCA 313 510-A	990	95.4	95.3	0.84	241	6.7	1273	2.4	2.7	
132	M2CA 355 SA	3GCA 353 110-A	992	95.3	95.1	0.85	235	6.8	1270	1.7	2.6	
160	M2CA 355 SB	3GCA 353 120-A	992	95.9	95.7	0.85	280	6.8	1540	1.8	2.7	
200	M2CA 355 MA	3GCA 353 310-A	993	95.9	95.7	0.85	350	7.5	1923	2.0	2.8	
250	<sup>1)</sup> M2CA 355 MB	3GCA 353 320-A	991	95.9	95.8	0.8	475	7.3	2409	2.2	3.0	
315	M2CA 355 LKD	3GCA 353 540-A	991	96.2	96.1	0.84	565	7.3	3035	2.0	3.0	
355	M2CA 400 MLA	3GCA 403 410-A	992	96.4	96.3	0.85	625	6.4	3417	1.2	2.7	
400	<sup>1)</sup> M2CA 400 MLB	3GCA 403 420-A	992	96.5	96.4	0.85	700	6.4	3850	1.2	2.7	
450	M2CA 400 LKA	3GCA 403 510-A	993	96.5	96.4	0.85	790	6.8	4327	1.3	2.8	
500	<sup>1)</sup> M2CA 400 LKB	3GCA 403 520-A	992	96.5	96.4	0.85	880	6.8	4813	1.3	2.8	
<b>1000 r/min = 6 poles</b>			<b>400 V 50 Hz</b>				<b>High-output design</b>					
75	M2CA 280 MB	3GCA 283 320-A	990	94.5	94.4	0.83	139	7.3	723	2.8	2.7	
90	M2CA 280 MC	3GCA 283 330-A	989	94.9	94.8	0.83	168	7.4	869	2.9	2.9	
110	M2CA 280 MD	3GCA 283 340-A	990	95.2	95.1	0.83	202	7.9	1061	3.1	3.0	
160	<sup>2)</sup> M2CA 315 LB	3GCA 313 520-A	991	95.6	95.4	0.83	292	7.7	1542	2.9	3.1	
200	<sup>2)</sup> M2CA 315 LC	3GCA 313 530-A	991	95.8	95.7	0.83	364	7.4	1927	2.8	2.9	
<b>750 r/min = 8 poles</b>			<b>400 V 50 Hz</b>				<b>Basic design</b>					
37	M2CA 280 SA	3GCA 284 110-A	741	93.4	93.1	0.78	74	7.3	477	1.8	3.1	
45	M2CA 280 SMA	3GCA 284 210-A	741	94.0	93.8	0.78	90	7.6	580	1.9	3.2	
55	M2CA 315 SA	3GCA 314 110-A	741	94.0	93.7	0.80	107	7.1	710	1.8	2.8	
75	M2CA 315 SMA	3GCA 314 210-A	740	94.5	94.2	0.81	142	7.1	968	1.8	2.8	
90	M2CA 315 MB	3GCA 314 320-A	740	94.7	94.5	0.82	169	7.3	1161	1.9	2.8	
110	<sup>2)</sup> M2CA 315 LA	3GCA 314 510-A	740	94.8	94.7	0.83	202	7.0	1420	1.9	2.7	
110	M2CA 355 SA	3GCA 354 110-A	742	94.6	94.0	0.80	215	5.6	1415	1.4	2.2	
132	M2CA 355 MA	3GCA 354 310-A	743	95.0	94.5	0.77	265	5.8	1696	1.5	2.3	
160	M2CA 355 MB	3GCA 354 320-A	742	95.2	94.8	0.79	310	6.4	2059	1.8	2.5	
200	M2CA 355 LKD	3GCA 354 540-A	743	95.5	95.1	0.74	414	6.6	2570	1.8	2.7	
250	M2CA 400 MLA	3GCA 404 410-A	744	96.0	95.7	0.77	490	7.2	3209	1.6	2.9	
315	<sup>1)</sup> M2CA 400 LKA	3GCA 404 510-A	744	96.2	95.9	0.79	605	6.9	4043	1.5	2.8	
<b>750 r/min = 8 poles</b>			<b>400 V 50 Hz</b>				<b>High-output design</b>					
55	M2CA 280 MB	3GCA 284 320-A	741	94.4	94.2	0.79	108	7.8	709	1.9	3.2	

<sup>1)</sup> Temperature rise acc. to class F.

<sup>2)</sup> Temperature rise acc. to class F by 380 V.

The two bullets in the product code indicate choice of mounting arrangement, voltage and frequency (see ordering information page).

# General purpose steel motors

## Technical data for totally enclosed squirrel cage three phase motors

IP 55 – IC 411 – Insulation class F, temperature rise class B

Output kW	Motor type	Speed r/min	Efficiency %	Power factor cos j	Current I <sub>N</sub> A	Speed r/min	Efficiency %	Power factor cos j	Current I <sub>N</sub> A	Moment of inertia J = ¼ GD <sup>2</sup> kgm <sup>2</sup>	Weight kg	Sound pressure level L <sub>p</sub> dB(A)
<b>1000 r/min = 6 poles</b>		<b>380 V 50 Hz</b>				<b>415 V 50 Hz</b>				<b>Basic design</b>		
45	M2CA 280 SA	988	94.0	0.83	89	991	94.2	0.81	82	1.65	440	66
55	M2CA 280 SMA	988	94.3	0.84	106	991	94.4	0.82	99	2	475	66
75	M2CA 315 SA	991	94.8	0.82	146	993	94.9	0.77	143	2.9	630	72
90	M2CA 315 SMA	990	95.2	0.84	173	992	95.3	0.82	162	3.8	720	72
110	M2CA 315 MB	990	95.1	0.84	212	992	95.3	0.82	198	4.5	805	75
132	M2CA 315 LA	988	95.3	0.84	252	991	95.5	0.83	234	5.4	910	75
132	M2CA 355 SA	991	95.2	0.86	245	993	95.3	0.84	230	8.7	1200	75
160	M2CA 355 SB	991	95.8	0.86	295	993	95.9	0.84	275	10	1320	75
200	M2CA 355 MA	992	95.8	0.86	370	993	95.9	0.84	350	13	1550	75
250 <sup>2)</sup>	M2CA 355 MB	990	95.8	0.82	485	992	95.9	0.78	470	13	1550	75
315	M2CA 355 LKD	990	96.2	0.85	590	992	96.2	0.82	560	15	1900	82
355	M2CA 400 MLA	991	96.3	0.86	650	993	96.4	0.84	610	17	2400	82
400 <sup>2)</sup>	M2CA 400 MLB	991	96.3	0.86	730	992	96.4	0.84	680	17	2400	82
450	M2CA 400 LKA	992	96.5	0.86	825	993	96.5	0.83	790	19	2700	82
500 <sup>2)</sup>	M2CA 400 LKB	991	96.5	0.86	920	993	96.5	0.83	870	19	2700	82
<b>1000 r/min = 6 poles</b>		<b>380 V 50 Hz</b>				<b>415 V 50 Hz</b>				<b>High-output design</b>		
75	M2CA 280 MB	988	94.5	0.84	144	991	94.5	0.81	137	2.6	545	67
90	M2CA 280 MC	988	94.8	0.84	174	990	94.9	0.81	164	3.1	815	67
110	M2CA 280 MD	988	95.1	0.84	210	991	95.2	0.81	200	4.1	835	67
160 <sup>3)</sup>	M2CA 315 LB	990	95.5	0.84	304	992	95.6	0.82	287	7.3	1200	80
200 <sup>3)</sup>	M2CA 315 LC	989	95.7	0.84	381	992	95.8	0.82	354	9.2	1380	80
<b>750 r/min = 8 poles</b>		<b>380 V 50 Hz</b>				<b>415 V 50 Hz</b>				<b>Basic design</b>		
37	M2CA 280 SA	740	93.2	0.8	75	742	93.4	0.76	73	1.85	460	65
45	M2CA 280 SMA	740	93.8	0.8	92	742	94.0	0.75	90	2.2	500	65
55	M2CA 315 SA	740	93.9	0.82	108	742	94.0	0.78	105	2.9	630	70
75	M2CA 315 SMA	739	94.3	0.82	148	741	94.3	0.79	138	3.8	715	70
90	M2CA 315 MB	739	94.6	0.83	175	741	94.6	0.8	165	4.5	800	77
110 <sup>3)</sup>	M2CA 315 LA	738	94.7	0.84	213	740	94.8	0.81	198	5.4	900	77
110	M2CA 355 SA	740	94.5	0.8	220	742	94.7	0.79	205	8.7	1200	75
132	M2CA 355 MA	742	94.8	0.78	270	744	95.0	0.75	260	10	1350	75
160	M2CA 355 MB	741	95.1	0.8	320	743	95.2	0.78	300	13	1550	75
200	M2CA 355 LKD	742	95.5	0.76	423	744	95.5	0.72	410	15	1900	80
250	M2CA 400 MLA	743	96.0	0.79	500	745	96.0	0.75	480	17	2400	80
315 <sup>3)</sup>	M2CA 400 LKA	743	96.1	0.8	620	745	96.2	0.76	600	19	2700	80
<b>750 r/min = 8 poles</b>		<b>380 V 50 Hz</b>				<b>415 V 50 Hz</b>				<b>High-output design</b>		
55	M2CA 280 MB	740	94.2	0.81	110	742	94.4	0.77	106	2.85	575	62

# General purpose steel motors

## Technical data for totally enclosed squirrel cage three phase motors, two-speed

IP 55 – IC 411 – Insulation class F, temperature rise class F

Output kW	Motor type	Product code	Speed r/min	Efficiency %	Power factor cos φ	Current		Torque			Moment of inertia		Weight kg
						I <sub>N</sub> A	I <sub>s</sub> A	T <sub>N</sub> Nm	T <sub>s</sub> Nm	T <sub>max</sub> Nm	J = ¼ GD <sup>2</sup> kgm <sup>2</sup>		
<b>1500/1000 r/min = 4/6 poles</b>			<b>400 V 50 Hz</b>			<b>Fan drive, two separate windings</b>							
60/18.5	M2CA 280 SA	3GCA 288 114-***A	1487/991	93.5/88.0	0.82/0.76	113/40	7.7/7.4	385/178	2.3/2.9	3.0/2.6	1.15	445	
77/25	M2CA 280 SMA	3GCA 288 214-***A	1486/991	93.9/89.3	0.83/0.76	144/54	7.6/7.7	495/241	2.4/3.2	2.9/2.7	1.4	490	
90/28	M2CA 280 MB	3GCA 288 324-***A	1485/991	94.2/89.8	0.86/0.78	161/58	7.4/7.7	579/270	2.3/3.2	2.7/2.8	1.7	550	
110/32	M2CA 315 SMA	3GCA 318 214-***A	1489/992	95.2/91.2	0.85/0.78	199/67	6.6/6.5	706/308	1.9/2.8	2.6/2.9	2.3	730	
125/37	M2CA 315 MB	3GCA 318 324-***A	1488/992	95.5/92.2	0.86/0.79	219/75	6.6/6.4	802/356	1.9/2.9	2.4/2.8	2.9	850	
150/44	M2CA 315 LA	3GCA 318 514-***A	1488/991	95.7/92.6	0.87/0.79	260/88	6.6/6.4	963/424	1.9/3.0	2.4/2.7	3.5	970	
180/55	M2CA 355 MA	3GCA 358 314-***A	1483/986	95.0/91.2	0.90/0.85	300/100	5.3/5.0	1159/532	1.1/1.3	2.3/2.2	6.5	1350	
260/85	M2CA 355 LA	3GCA 358 514-***A	1487/988	95.7/92.0	0.90/0.85	435/155	7.7/5.9	1670/821	1.7/1.6	3.2/2.4	7.8	1550	
<b>1500/750 r/min = 4 - 8 poles</b>			<b>400 V 50 Hz</b>			<b>Fan drive, Dahlander-connection</b>							
65/15	M2CA 280 SA	3GCA 288 119-***A	1484/743	93.2/90.0	0.84/0.63	121/38	7.5/5.3	418/193	2.7/2.8	2.9/2.3	1.15	445	
80/20	M2CA 280 SMA	3GCA 288 219-***A	1486/743	93.8/91.5	0.83/0.63	150/50	8.5/5.4	514/257	3.3/2.9	3.4/2.6	1.4	490	
90/23	M2CA 280 MB	3GCA 288 329-***A	1486/742	94.1/91.8	0.85/0.64	164/56	8.8/5.4	578/296	3.6/2.8	3.5/2.6	1.7	550	
110/22	M2CA 315 SMA	3GCA 318 219-***A	1487/744	94.6/92.5	0.85/0.62	197/56	6.8/4.9	706/282	1.9/2.1	2.6/2.5	2.3	730	
132/26	M2CA 315 MB	3GCA 318 329-***A	1486/746	94.9/93.0	0.86/0.64	235/65	6.8/4.8	848/334	2.0/2.0	2.6/2.4	2.9	850	
160/32	M2CA 315 LA	3GCA 318 519-***A	1486/743	95.2/93.4	0.86/0.64	283/80	7.0/4.8	1028/411	2.1/2.1	2.7/2.5	3.5	970	
200/40	M2CA 355 MA	3GCA 358 319-***A	1489/745	95.3/93.7	0.90/0.68	340/90	6.8/4.8	1282/512	1.4/1.3	2.8/2.5	6.5	1350	
250/50	M2CA 355 LA	3GCA 358 519-***A	1490/745	95.5/94.0	0.87/0.64	435/120	7.5/5.1	1602/641	1.5/1.4	3.2/2.6	7.8	1550	
<b>1500/1000 r/min = 4/6 poles</b>			<b>400 V 50 Hz</b>			<b>Constant torque, two separate windings</b>							
50/32	M2CA 280 SA	3GCA 289 114-***A	1486/987	92.0/90.5	0.84/0.78	94/65	6.9/6.2	321/310	2.0/2.5	2.6/2.2	1.15	445	
60/40	M2CA 280 SMA	3GCA 289 214-***A	1486/987	92.6/91.8	0.85/0.78	111/82	7.1/6.6	386/387	2.1/2.8	2.7/2.3	1.4	490	
70/47	M2CA 280 MB	3GCA 289 324-***A	1488/989	93.2/92.6	0.84/0.77	131/96	8.0/7.4	450/454	2.6/3.4	3.1/2.5	1.7	550	
90/60	M2CA 315 SMA	3GCA 319 214-***A	1488/990	94.3/93.5	0.86/0.77	161/121	5.9/5.8	577/579	1.5/2.6	2.3/2.4	2.3	730	
110/75	M2CA 315 MB	3GCA 319 324-***A	1490/989	94.9/93.9	0.86/0.79	195/147	6.8/5.6	705/724	1.9/2.7	2.6/2.3	2.9	850	
132/90	M2CA 315 LA	3GCA 319 514-***A	1489/990	95.1/94.1	0.85/0.76	238/181	6.7/6.0	847/868	1.9/3.1	2.7/2.7	3.5	970	
160/110	M2CA 315 LB	3GCA 319 524-***A	1491/990	95.3/94.5	0.85/0.79	287/213	7.2/5.8	1025/1061	2.1/2.8	2.7/2.3	3.9	1000	
180/120	M2CA 355 MA	3GCA 359 314-***A	1488/990	95.0/94.3	0.89/0.80	305/230	7.2/7.3	1155/1157	1.4/2.0	3.1/3.1	6.5	1350	
230/150	M2CA 355 LA	3GCA 359 514-***A	1489/990	95.3/94.5	0.89/0.82	395/280	7.7/6.9	1475/1447	1.5/2.0	3.2/2.9	7.8	1550	
<b>1500/750 r/min = 4 - 8 poles</b>			<b>400 V 50 Hz</b>			<b>Constant torque, Dahlander-connection</b>							
50/32	M2CA 280 SA	3GCA 289 119-***A	1486/743	92.7/91.8	0.88/0.70	89/72	7.2/6.9	321/411	1.9/2.7	2.6/2.5	1.85	460	
65/40	M2CA 280 SMA	3GCA 289 219-***A	1486/743	93.1/92.0	0.88/0.69	115/92	7.7/7.2	418/514	2.1/3.1	2.7/2.7	2.2	500	
85/50	M2CA 280 MB	3GCA 289 329-***A	1487/743	93.8/92.8	0.88/0.68	149/115	8.5/7.7	546/643	2.5/3.4	2.9/2.9	2.85	575	
100/65	M2CA 315 SMA	3GCA 319 219-***A	1487/742	94.2/93.8	0.89/0.74	174/137	6.5/6.3	642/836	1.5/2.1	2.6/2.5	4.1	755	
120/75	M2CA 315 MB	3GCA 319 329-***A	1486/742	94.5/94.1	0.90/0.74	204/155	7.0/6.5	739/965	1.7/2.2	2.6/2.6	4.9	845	
150/95	M2CA 315 LA	3GCA 319 519-***A	1486/742	94.7/94.2	0.89/0.72	262/204	7.2/6.5	964/1223	2.0/2.4	2.8/2.6	5.8	950	
150/100	M2CA 355 MA	3GCA 359 319-***A	1487/741	94.7/94.3	0.90/0.72	255/210	5.6/4.4	963/1288	1.2/1.2	2.5/2.2	6.5	1350	
180/130	M2CA 355 LA	3GCA 359 519-***A	1488/742	95.2/94.6	0.90/0.72	305/275	6.6/4.5	1155/1673	1.4/1.3	2.8/2.2	7.8	1550	

Data for other number of poles and frame size 400 on request.

The two bullets in the product code indicate choice of mounting arrangement, voltage and frequency (see ordering information page).

# General purpose steel motors - Variant codes

Code <sup>1)</sup>	Variant	Motor size			
		280	315	355	400
<b>Balancing</b>					
052	Balancing to grade R (IEC 60034-14).	P	P	P	P
417	Balancing to grade S (IEC 60034-14).	P	P	P	P
424	Full key balancing.	P	P	P	P
<b>Bearings and lubrication</b>					
036	Transport lock for bearings.	M	M	M	M
037	Roller bearing at D-end.	M	M	M	R
039	Cold resistant grease. For bearing temperatures -55 - +100°C.	M	M	M	M
043	SPM-nipples.	M	M	M	M
058	Angular contact bearing at D-end, shaft force away from bearing.	P	P	P	P
060	Angular contact bearing at D-end, shaft force towards bearing.	P	P	P	P
107	Bearing mounted PT100 resistance elements.	P	P	P	P
420	Bearing mounted PTC thermistors.	P	P	P	P
<b>Branch standard designs</b>					
071	Cooling tower duty. Only motors with shaft extensions downwards.	R	R	R	R
142	"Manilla"-winding connection, (440 VΔ series, 220 VΔ parallel, 60 Hz).	P	P	P	P
178	Stainless steel/acid proof bolts.	P	P	P	P
209	Non-standard voltage or frequency (special winding).	P	P	P	P
425	Corrosion protected stator and rotor core.	P	P	P	P
432	Copper bar rotor.	NA	NA	R	R
<b>Cooling system</b>					
044	Unidirectional fan, clockwise seen from D-end.	R	R	R	R
045	Unidirectional fan, counter clockwise seen from D-end.	R	R	R	R
068	Metal fan.	M	M	M	M
075	Cooling method IC 418 (without fan).	P	P	P	P
<b>Coupling</b>					
035	Assembly of customer supplied coupling-half (finish bored and balanced).	M	M	M	M
<b>Dimension drawing</b>					
141	Binding dimension drawing.	M	M	M	M
<b>Drain holes</b>					
065	Plugged drain holes.	M	M	M	M
066	Modified drain hole position (for specified IM xxxx).	M	M	M	M
<b>Earthing bolt</b>					
067	External earthing bolt.	M	M	M	M
<b>Heating elements</b>					
450	Heating element, 100-120 V.	P	P	P	P
451	Heating element, 200-240 V.	M	M	M	M

<sup>1)</sup> Certain variant codes cannot be used simultaneously.

**S** = Included as standard

**M** = On modification of a stocked motor,  
or on new manufacture,  
the number per order may be limited.

**P** = New manufacture only.

**R** = On request.

**NA** = Not applicable

Code <sup>1)</sup>	Variant	M2CA, motor size			
		280	315	355	400
<b>Insulation system</b>					
405	Special winding insulation for frequency converter supply.	R	R	R	R
406	Winding for supply > 690 ≤ 1000 V.	R	R	R	R
<b>Mounting arrangements</b>					
009	IM 2001 foot/flange mounted, IEC flange, from IM 1001 (B35 from B3).	M	M	M	M
<b>Painting</b>					
114	Special paint colour, standard grade.	M	M	M	M
179	Special paint specification.	P	P	P	P
<b>Protection</b>					
072	Radial seal at D-end.	M	M	M	M
073	Sealed against oil at D-end.	P	P	P	P
005	Protective roof, vertical motor, shaft down.	M	M	M	M
403	Degree of protection IP 56.	M	M	M	M
<b>Rating &amp; instruction plates</b>					
002	Restamping voltage, frequency and output, continuous duty.	M	M	M	M
013	Restamping to output for class F temperature rise. Applies to variants with temperature rise to class B as standard.	M	M	M	M
095	Restamping output (maintained voltage, frequency), intermittent duty.	M	M	M	M
138	Mounting of additional identification plate.	M	M	M	M
150	Instruction plates and maintenance instructions in non-standard language.	R	R	R	R
161	Additional rating plate delivered loose.	M	M	M	M
<b>Shaft &amp; rotor</b>					
069	Two shaft extensions as per basic catalogue. Standard shaft material.	P	P	P	P
070	One or two special shaft extensions, standard shaft material.	P	P	P	P
410	Stainless/acid-proof steel shaft (standard or non-standard design). One or two extensions.	P	P	P	P
<b>Standards and regulations</b>					
010	Fulfilling CSA requirements.	P	P	P	P
153	Reduced test for classification society.	P	P	P	P
<b>Stator winding temperature sensors</b>					
121	Bimetal detectors, break type (NCC), (3 in series), 130°C, in stator winding.	M	M	M	M
122	Bimetal detectors, break type (NCC), (3 in series), 150°C, in stator winding.	M	M	M	M
123	Bimetal detectors, break type (NCC), (3 in series), 170°C, in stator winding.	M	M	M	M
125	Bimetal detectors, break type (NCC), (2x3 in series), 150°C, in stator winding.	M	M	M	M
127	Bimetal detectors, break type (NCC), (3 in series, 130°C & 3 in series, 150°C), in stator winding.	M	M	M	M
435	PTC - thermistors (3 in series), 130°C, in stator winding.	M	M	M	M
436	PTC - thermistors (3 in series), 150°C, in stator winding.	S	S	S	S
437	PTC - thermistors (3 in series), 170°C, in stator winding.	M	M	M	M

<sup>1)</sup> Certain variant codes cannot be used simultaneously.

**S** = Included as standard  
**M** = On modification of a stocked motor,  
or on new manufacture,  
the number per order may be limited.

**P** = New manufacture only.  
**R** = On request.  
**NA** = Not applicable

Code <sup>1)</sup>	Variant	M2CA, motor size			
		280	315	355	400
439	PTC - thermistors (2x3 in series), 150°C, in stator winding.	M	M	M	M
441	PTC - thermistors (3 in series 130°C & 3 in series 150°C), in stator winding.	M	M	M	M
442	PTC - thermistors (3 in series 150°C & 3 in series 170°C), in stator winding.	M	M	M	M
446	PT100 resistance elements (2 per phase) in stator winding.	M	M	M	M
446	PT100 resistance elements (2 per phase) in stator winding.	M	M	M	M
<b>Terminal box</b>					
015	Motor supplied in D-connection.	M	M	M	M
017	Motor supplied in Y-connection.	M	M	M	M
019	Larger than standard terminal box.	R	R	R	R
137	Extended cable connection, low terminal box.	P	P	R	R
157	Terminal box degree of protection IP 65.	M	M	M	M
413	Extended cable connection, no terminal box.	P	P	P	R
414	Smaller than standard terminal box.	P	P	P	P
418	Separate terminal box for temperature detectors.	P	P	P	P
468	Non-standard cable entry direction (please state direction).	M	M	M	M
469	Axial cable entry direction, terminal box 4x90° turnable.	P	P	P	P
<b>Testing</b>					
145	Type test report from test of identical motor.	M	M	M	M
146	Type test with report for motor from specific delivery batch.	P	P	P	P
147	Type test with report for motor from specific delivery batch, customer witnessed.	P	P	P	P
148	Routine test report.	M	M	M	M
149	Testing according to separate test specification.	R	R	R	R
760	Vibration level test.	P	P	P	P
761	Vibration spectrum test.	P	P	P	P
762	Noise level test.	P	P	P	P
763	Noise spectrum test.	P	P	P	P
<b>Y/D-starting</b>					
117	Terminals for Y/Δ start at both speeds (two speed windings).	P	P	P	P
118	Terminals for Y/Δ start at high speed (two speed windings).	P	P	P	P
119	Terminals for Y/Δ start at low speed (two speed windings).	P	P	P	P

<sup>1)</sup> Certain variant codes cannot be used simultaneously.

**S** = Included as standard

**M** = On modification of a stocked motor, or on new manufacture, the number per order may be limited.

**P** = New manufacture only.

**R** = On request.

**NA** = Not applicable

# General purpose steel motors

# Sizes 280-315

## Dimension drawings

Foot-mounted; IM B3 (IM 1001), IM B6 (IM 1051), IM B7 (IM 1061), IM B8 (IM 1071), IM V5 (IM 1011), IM V6 (IM 1031) – terminal box top mounted

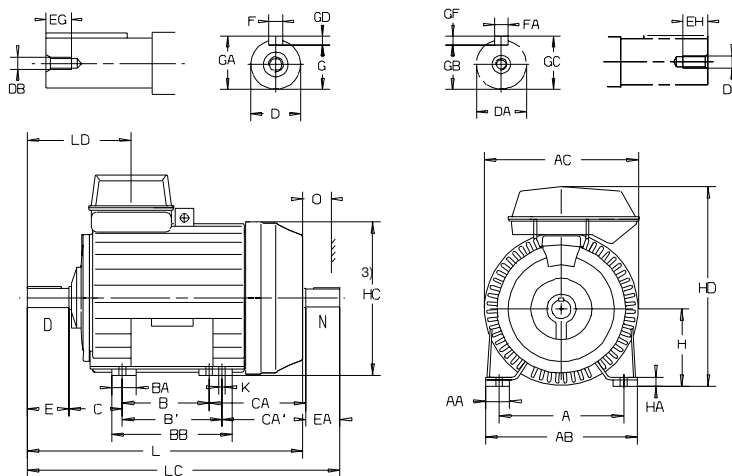

Motor size	Poles <sup>1)</sup>	A	AA	AB	AC	B	B'	BA	BB	C	CA	CA'	D	DA	DB	DC	E	EA	EG	EH
280 SA	2	457	80	545	555	368	—	100	501	190	372	—	65	60	M20	M20	140	140	40	40
	4-8	457	80	545	555	368	—	100	450	190	302	—	75	65	M20	M20	140	140	40	40
280 SMA	2	457	80	545	555	368	419	100	501	190	372	321	65	60	M20	M20	140	140	40	40
	4-8	457	80	545	555	368	419	100	501	190	372	321	75	65	M20	M20	140	140	40	40
280 MB	2	457	80	545	555	419	—	100	501	190	381	—	65	60	M20	M20	140	140	40	40
	4-8	457	80	545	555	419	—	100	501	190	381	—	75	65	M20	M20	140	140	40	40
280 MC,MD2	2	457	80	545	555	419	—	100	501	190	381	—	65	60	M20	M20	140	140	40	40
	4-8	457	80	545	555	419	—	100	501	190	381	—	75	65	M20	M20	140	140	40	40
315 SA	2	508	100	622	624	406	—	100	539	216	343	—	65	60	M20	M20	140	140	40	40
	4-8	508	100	622	624	406	—	100	539	216	343	—	80	75	M20	M20	170	140	40	40
315 SMA	2	508	100	622	624	406	457	100	539	216	443	392	65	60	M20	M20	140	140	40	40
	4-8	508	100	622	624	406	457	100	539	216	343	292	80	75	M20	M20	170	140	40	40
315 MB	2	508	100	622	624	457	—	100	539	216	392	—	65	60	M20	M20	140	140	40	40
	4-8	508	100	622	624	457	—	100	539	216	392	—	80	75	M20	M20	170	140	40	40
315 LA	2	508	100	622	624	508	—	100	592	216	411	—	65	60	M20	M20	140	140	40	40
	4-8	508	100	622	624	508	—	100	592	216	411	—	90	75	M24	M20	170	140	48	40
315 LB,LC	2	508	100	622	624	508	—	100	592	216	411	—	65	60	M20	M20	140	140	40	40
	4-8	508	100	622	624	508	—	100	592	216	411	—	90	75	M24	M20	170	140	48	40

Motor size	Poles <sup>1)</sup>	F	FA	G	GA	GB	GC	GD	GF	H	HA	HC	HD	K	L	LC	LD	O
280 SA	2	18	18	58	69	53	64	11	11	280	32	558	730	24	1060	1210	385	100
	4-8	20	18	67.5	79.5	58	69	12	11	280	32	558	730	24	990	1140	385	100
280 SMA	2	18	18	58	69	53	64	11	11	280	32	558	730	24	1060	1210	385	100
	4-8	20	18	67.5	79.5	58	69	12	11	280	32	558	730	24	1060	1210	385	100
280 MB	2	18	18	58	69	53	64	11	11	280	32	558	730	24	1120	1270	385	100
	4-8	20	18	67.5	79.5	58	69	12	11	280	32	558	730	24	1120	1270	385	100
280 MC	2	18	18	58	69	53	64	11	11	280	32	555	730	24	1255	1405	385	100
	4-8	20	18	67.5	79.5	58	69	12	11	280	32	558	730	24	1255	1405	385	100
280 MD	2	18	18	58	69	53	64	11	11	280	32	558	730	24	1255	1405	385	100
	4-8	20	18	67.5	79.5	58	69	12	11	280	32	558	730	24	1255	1405	385	100
315 SA	2	18	18	58	69	53	64	11	11	315	32	627	820	28	1095	1245	390	115
	4-8	22	20	71	85	67.5	79.5	14	12	315	32	627	820	28	1125	1275	420	115
315 SMA	2	18	18	58	69	53	64	11	11	315	32	627	820	28	1195	1345	390	115
	4-8	22	20	71	85	67.5	79.5	14	12	315	32	627	820	28	1125	1275	420	115
315 MB	2	18	18	58	69	53	64	11	11	315	32	627	820	28	1195	1345	390	115
	4-8	22	20	71	85	67.5	79.5	14	12	315	32	627	820	28	1225	1375	420	115
315 LA	2	18	18	58	69	53	64	11	11	315	32	627	820	28	1265	1415	390	115
	4-8	25	20	81	95	67.5	79.5	14	12	315	32	627	820	28	1295	1445	420	115
315 LB	2	18	18	58	69	53	64	11	11	315	32	627	820	28	1545	1695	390	115
	4-8	25	20	81	95	67.5	79.5	14	12	315	32	627	820	28	1575	1725	420	115
315 LC	2	18	18	58	69	53	64	11	11	315	32	627	848	28	1545	1695	390	115
	4	25	20	81	95	67.5	79.5	14	12	315	32	627	848	28	1575	1725	420	115
	6	25	20	81	95	67.5	79.5	14	12	315	32	627	820	28	1575	1725	420	115

Tolerances:

A, B ISO js14 H ISO 0, -1.0  
 D, DA ISO m6  
 F, FA ISO h9

<sup>1)</sup> Dimensions for 4-pole motors also valid for 4/6- and 4-8 -pole two-speed motors.

<sup>2)</sup> Cooling distance.

<sup>3)</sup> Second shaft end on request.

Above dimensions are in mm.  
 For detailed drawings please see our web-pages 'www.abb.com/motors&drives' or contact us.



# General purpose steel motors

# Sizes 280-315

## Dimension drawings

Foot-mounted; IM B3 (IM 1001), IM B6 (IM 1051), IM B7 (IM 1061), IM B8 (IM 1071), IM V5 (IM 1011), IM V6 (IM 1031) – terminal box side mounted

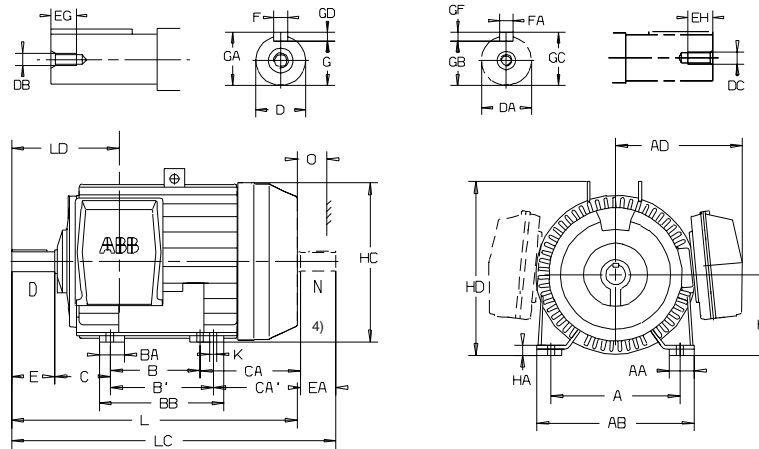

Motor size	Poles <sup>1)</sup>	A	AA	AB	AD	B	B'	BA	BB	C	CA	CA'	D	DA	DB	DC	E	EA	EG	EH
280 SA	2	457	80	545	448	368	–	100	501	190	372	–	65	60	M20	M20	140	140	40	40
	4-8	457	80	545	448	368	–	100	450	190	302	–	75	65	M20	M20	140	140	40	40
280 SMA	2	457	80	545	448	368	419	100	501	190	372	321	65	60	M20	M20	140	140	40	40
	4-8	457	80	545	448	368	419	100	501	190	372	321	75	65	M20	M20	140	140	40	40
280 MB	2	457	80	545	448	419	–	100	501	190	381	–	65	60	M20	M20	140	140	40	40
	4-8	457	80	545	448	419	–	100	501	190	381	–	75	65	M20	M20	140	140	40	40
280 MC,MD	2	457	80	545	448	419	–	100	501	190	381	–	65	60	M20	M20	140	140	40	40
	4-8	457	80	545	448	419	–	100	501	190	381	–	75	65	M20	M20	140	140	40	40
315 SA	2	508	100	622	502	406	–	100	539	216	343	–	65	60	M20	M20	140	140	40	40
	4-8	508	100	622	502	406	–	100	539	216	343	–	80	75	M20	M20	170	140	40	40
315 SMA	2	508	100	622	502	406	457	100	539	216	443	392	65	60	M20	M20	140	140	40	40
	4-8	508	100	622	502	406	457	100	539	216	343	292	80	75	M20	M20	170	140	40	40
315 MB	2	508	100	622	502	457	–	100	539	216	392	–	65	60	M20	M20	140	140	40	40
	4-8	508	100	622	502	457	–	100	539	216	392	–	80	75	M20	M20	170	140	40	40
315 LA	2	508	100	622	502	508	–	100	592	216	411	–	65	60	M20	M20	140	140	40	40
	4-8	508	100	622	502	508	–	100	592	216	411	–	90	75	M24	M20	170	140	48	40
315 LB,LC	2	508	100	622	502	508	–	100	592	216	411	–	65	60	M20	M20	140	140	40	40
	4-8	508	100	622	502	508	–	100	592	216	411	–	90	75	M24	M20	170	140	48	40

Motor size	Poles <sup>1)</sup>	F	FA	G	GA	GB	GC	GD	GF	H	HA	HC	HD	K	L	LC	LD	O
280 SA	2	18	18	58	69	53	64	11	11	280	32	558	620	24	1060	1210	385	100
	4-8	20	18	67.5	79.5	58	69	12	11	280	32	558	620	24	990	1140	385	100
280 SMA	2	18	18	58	69	53	64	11	11	280	32	558	620	24	1060	1210	385	100
	4-8	20	18	67.5	79.5	58	69	12	11	280	32	558	620	24	1060	1210	385	100
280 MB	2	18	18	58	69	53	64	11	11	280	32	558	620	24	1120	1270	385	100
	4-8	20	18	67.5	79.5	58	69	12	11	280	32	558	620	24	1120	1270	385	100
280 MC	2	18	18	58	69	53	64	11	11	280	32	558	620	24	1255	1405	385	100
	4-8	20	18	67.5	79.5	58	69	12	11	280	32	558	620	24	1255	1405	385	100
280 MD	2	18	18	58	69	53	64	11	11	280	32	558	620	24	1255	1405	385	100
	4-8	20	18	67.5	79.5	58	69	12	11	280	32	558	620	24	1255	1405	385	100
315 SA	2	18	18	58	69	53	64	11	11	315	32	627	685	28	1095	1245	390	115
	4-8	22	20	71	85	67.5	79.5	14	12	315	32	627	685	28	1125	1275	420	115
315 SMA	2	18	18	58	69	53	64	11	11	315	32	627	685	28	1195	1345	390	115
	4-8	22	20	71	85	67.5	79.5	14	12	315	32	627	685	28	1125	1275	420	115
315 MB	2	18	18	58	69	53	64	11	11	315	32	627	685	28	1195	1345	390	115
	4-8	22	20	71	85	67.5	79.5	14	12	315	32	627	685	28	1225	1375	420	115
315 LA	2	18	18	58	69	53	64	11	11	315	32	627	685	28	1265	1415	390	115
	4-8	25	20	81	95	67.5	79.5	14	12	315	32	627	685	28	1295	1445	420	115
315 LB,LC	2	18	18	58	69	53	64	11	11	315	32	627	685	28	1545	1695	390	115
	4-8	25	20	81	95	67.5	79.5	14	12	315	32	627	685	28	1575	1575	420	115

Tolerances:

A, B ISO js14 H ISO 0, -1.0  
 D, DA ISO m6  
 F, FA ISO h9

<sup>1)</sup> Dimensions for 4-pole motors also valid for 4/6- and 4-8 -pole two-speed motors.

<sup>2)</sup> Cooling distance.

<sup>3)</sup> Second shaft end on request.

Above dimensions are in mm.

For detailed drawings please see our web-pages 'www.abb.com/motors&drives' or contact us.

# General purpose steel motors

# Sizes 355-400

## Dimension drawings

Foot-mounted; IM B3 (IM 1001), IM B6 (IM 1051), IM B7 (IM 1061), IM B8 (IM 1071), IM V5 (IM 1011), IM V6 (IM 1031) – terminal box top mounted

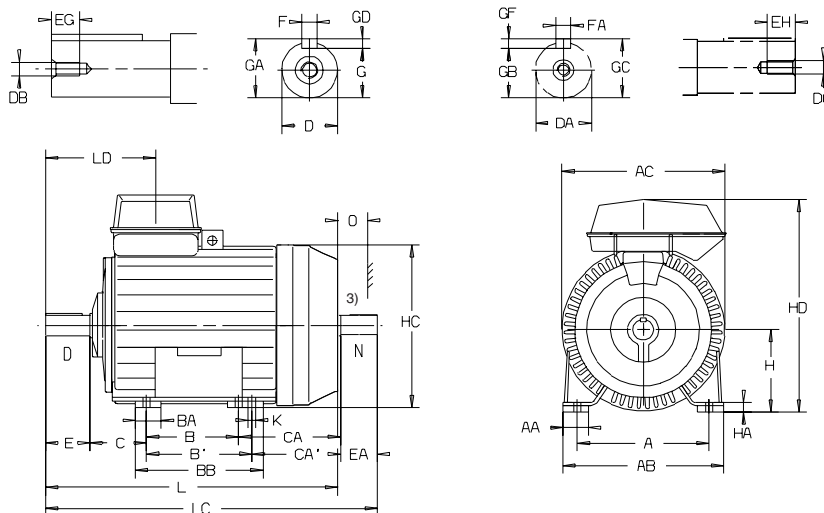

Motor size	Poles <sup>1)</sup>	A	AA	AB	AC	B	B'	BA	BB	C	CA	CA'	D	DA	DB	DC	E	EA	EG	EH
<b>355 SA,SB</b>	2	610	110	714	720	500	–	100	584	254	416	–	70	70	M20	M20	140	140	40	40
	4-8	610	110	714	720	500	–	100	584	254	416	–	100	90	M24	M20	210	170	48	48
<b>355 MA</b>	2	610	110	714	720	560	–	100	644	254	416	–	70	70	M20	M20	140	140	40	40
	4-8	610	110	714	720	560	–	100	644	254	416	–	100	90	M24	M24	210	170	48	48
<b>355 MB</b>	2	610	110	714	720	560	–	100	644	254	416	–	70	70	M20	M20	140	140	40	40
	4-8	610	110	714	720	560	–	100	644	254	416	–	100	90	M24	M24	210	170	48	48
<b>355 LA</b>	2	610	110	714	720	630	–	100	714	254	426	–	70	70	M20	M20	140	140	40	40
	4-8	610	110	714	720	630	–	100	714	254	426	–	100	90	M24	M24	210	170	48	48
<b>355 LB</b>	2	610	110	714	720	630	–	100	714	254	426	–	70	70	M20	M20	140	140	40	40
	4-8	610	110	714	720	630	–	100	714	254	426	–	100	90	M24	M24	210	170	48	48
<b>355 LKD</b>	4-8	610	110	714	720	630	710	100	802	254	583	503	100	90	M24	M24	210	170	48	48
<b>400 MLA</b>	2	686	140	820	810	630	710	140	850	280	583	503	70	70	M20	M20	140	140	40	40
	4-8	686	140	820	810	630	710	140	850	280	583	503	100	90	M24	M24	210	170	48	48
<b>400 MLB</b>	2	686	140	820	810	630	710	140	850	280	583	503	70	70	M20	M20	140	140	40	40
	4-8	686	140	820	810	630	710	140	850	280	583	503	100	90	M24	M24	210	170	48	48
<b>400 LKA</b>	2	686	140	820	810	710	800	140	935	280	643	553	80	75	M20	M20	170	140	40	40
	4-8	686	140	820	810	710	800	140	935	280	643	553	100	90	M24	M24	210	170	48	48
<b>400 LKB</b>	2	686	140	820	810	710	800	140	935	280	643	553	80	75	M20	M20	170	140	40	40
	4-8	686	140	820	810	710	800	140	935	280	643	553	100	90	M24	M24	210	170	48	48

Motor size	Poles <sup>1)</sup>	F	FA	G	GA	GB	GC	GD	GF	H	HA	HC	HD	K	L	LC	LD	O <sup>2)</sup>
<b>355 SA,SB</b>	2	20	20	62.5	74.5	62.5	74.5	12	12	355	36	715	920	28	1310	1460	392	130
	4-8	28	25	90	106	81	95	16	14	355	36	715	920	28	1380	1560	462	130
<b>355 MA</b>	2	20	20	62.5	74.5	62.5	74.5	12	12	355	36	715	920	28	1370	1520	392	130
	4-8	28	25	90	106	81	95	16	14	355	36	715	920	28	1440	1620	462	130
<b>355 MB</b>	2	20	20	62.5	74.5	62.5	74.5	12	12	355	36	715	920	28	1370	1520	392	130
	4-8	28	25	90	106	81	95	16	14	355	36	715	920	28	1440	1620	462	130
<b>355 LA</b>	2	20	20	62.5	74.5	62.5	74.5	12	12	355	36	715	920	28	1450	1600	392	130
	4-8	28	25	90	106	81	95	16	14	355	36	715	920	28	1520	1700	462	130
<b>355 LB</b>	2	20	20	62.5	74.5	62.5	74.5	12	12	355	36	715	920	28	1450	1600	392	130
	4-8	28	25	90	106	81	95	16	14	355	36	715	920	28	1520	1700	462	130
<b>355 LKD</b>	4-8	28	25	90	106	91	95	16	14	355	36	715	920	28	1660	1847	462	130
<b>400 MLA</b>	2	20	20	62.5	74.5	62.5	74.5	12	12	400	45	805	1003	35	1616	1773	408	150
	4-8	28	25	90	106	81	95	16	14	400	45	805	1003	35	1686	1873	478	150
<b>400 MLB</b>	2	20	20	62.5	74.5	62.5	74.5	12	12	400	45	805	1003	35	1616	1773	408	150
	4-8	28	25	90	106	81	95	16	14	400	45	805	1003	35	1686	1873	478	150
<b>400 LKA</b>	2	22	20	71	85	67.5	79.5	14	12	400	45	805	1003	35	1786	1943	438	150
	4-8	28	25	90	106	81	95	16	14	400	45	805	1003	35	1826	2013	478	150
<b>400 LKB</b>	2	22	20	71	85	67.5	79.5	14	12	400	45	805	1003	35	1786	1943	438	150
	4-8	28	25	90	106	81	95	16	14	400	45	805	1003	35	1826	2013	478	150

Tolerances:

A, B ISO js14 H ISO 0, -1.0  
D, DA ISO m6  
F, FA ISO h9

<sup>1)</sup> Dimensions for 4-pole motors also valid for 4/6- and 4-8 -pole two-speed motors.

<sup>2)</sup> Cooling distance.

<sup>3)</sup> Second shaft end on request.

Above dimensions are in mm.  
For detailed drawings please see our web-pages 'www.abb.com/motors&drives' or contact us.

# General purpose steel motors

# Sizes 355-400

## Dimension drawings

Foot-mounted; IM B3 (IM 1001), IM B6 (IM 1051), IM B7 (IM 1061), IM B8 (IM 1071), IM V5 (IM 1011), IM V6 (IM 1031) – terminal box side mounted

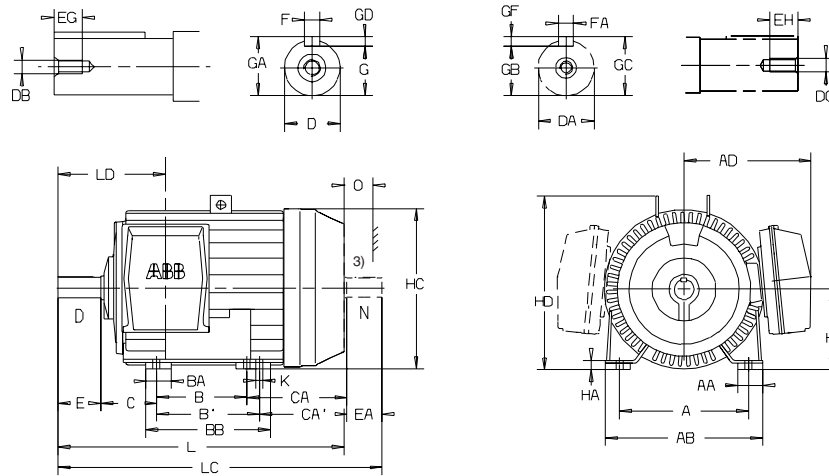

Motor size	Poles <sup>1)</sup>	A	AA	AB	AD	B	B'	BA	BB	C	CA	CA'	D	DA	DB	DC	E	EA	EG	EH
355 SA,SB	2	610	110	714	570	500	–	100	584	254	416	–	70	70	M20	M20	140	140	40	40
	4-8	610	110	714	570	500	–	100	584	254	416	–	100	90	M24	M20	210	170	48	48
355 MA	2	610	110	714	570	560	–	100	644	254	416	–	70	70	M20	M20	140	140	40	40
	4-8	610	110	714	570	560	–	100	644	254	416	–	100	90	M24	M24	210	170	48	48
355 MB	2	610	110	714	570	560	–	100	644	254	416	–	70	70	M20	M20	140	140	40	40
	4-8	610	110	714	570	560	–	100	644	254	416	–	100	90	M24	M24	210	170	48	48
355 LA	2	610	110	714	570	630	–	100	714	254	426	–	70	70	M20	M20	140	140	40	40
	4-8	610	110	714	570	630	–	100	714	254	426	–	100	90	M24	M24	210	170	48	48
355 LB	2	610	110	714	570	630	–	100	714	254	426	–	70	70	M20	M20	140	140	40	40
	4-8	610	110	714	570	630	–	100	714	254	426	–	100	90	M24	M24	210	170	48	48
355 LKD	4-8	610	110	714	570	630	710	100	802	254	583	503	100	90	M24	M24	210	170	48	48
400 MLA	2	686	140	820	603	630	710	140	850	280	583	503	70	70	M20	M20	140	140	40	40
	4-8	686	140	820	603	630	710	140	850	280	583	503	100	90	M24	M24	210	170	48	48
400 MLB	2	686	140	820	603	630	710	140	850	280	583	503	70	70	M20	M20	140	140	40	40
	4-8	686	140	820	603	630	710	140	850	280	583	503	100	90	M24	M24	210	170	48	48
400 LKA	2	686	140	820	603	710	800	140	935	280	643	553	80	75	M20	M20	170	140	40	40
	4-8	686	140	820	603	710	800	140	935	280	643	553	100	90	M24	M24	210	170	48	48
400 LKB	2	686	140	820	603	710	800	140	935	280	643	553	80	75	M20	M20	170	140	40	40
	4-8	686	140	820	603	710	800	140	935	280	643	553	100	90	M24	M24	210	170	48	48

Motor size	Poles <sup>1)</sup>	F	FA	G	GA	GB	GC	GD	GF	H	HA	HC	HD	K	L	LC	LD	O <sup>2)</sup>
355 SA,SB	2	20	20	62.5	74.5	62.5	74.5	12	12	355	36	715	768	28	1310	1460	392	130
	4-8	28	25	90	106	81	95	16	14	355	36	715	768	28	1380	1560	462	130
355 MA	2	20	20	62.5	74.5	62.5	74.5	12	12	355	36	715	768	28	1370	1520	392	130
	4-8	28	25	90	106	81	95	16	14	355	36	715	768	28	1440	1620	462	130
355 MB	2	20	20	62.5	74.5	62.5	74.5	12	12	355	36	715	768	28	1370	1520	392	130
	4-8	28	25	90	106	81	95	16	14	355	36	715	768	28	1440	1620	462	130
355 LA	2	20	20	62.5	74.5	62.5	74.5	12	12	355	36	715	768	28	1450	1600	392	130
	4-8	28	25	90	106	81	95	16	14	355	36	715	768	28	1520	1700	462	130
355 LB	2	20	20	62.5	74.5	62.5	74.5	12	12	355	36	715	768	28	1450	1600	392	130
	4-8	28	25	90	106	81	95	16	14	355	36	715	768	28	1520	1700	462	130
355 LKD	4-8	28	25	90	106	91	95	16	14	355	36	715	768	28	1660	1847	462	130
400 MLA	2	20	20	62.5	74.5	62.5	74.5	12	12	400	45	805	900	35	1616	1773	408	150
	4-8	28	25	90	106	81	95	16	14	400	45	805	900	35	1686	1873	478	150
400 MLB	2	20	20	62.5	74.5	62.5	74.5	12	12	400	45	805	900	35	1616	1773	408	150
	4-8	28	25	90	106	81	95	16	14	400	45	805	900	35	1686	1873	478	150
400 LKA	2	22	20	71	85	67.5	79.5	14	12	400	45	805	900	35	1786	1943	438	150
	4-8	28	25	90	106	81	95	16	14	400	45	805	900	35	1826	2013	478	150
400 LKB	2	22	20	71	85	67.5	79.5	14	12	400	45	805	900	35	1786	1943	438	150
	4-8	28	25	90	106	81	95	16	14	400	45	805	900	35	1826	2013	478	150

Tolerances:

A, B ISO js14 H ISO 0, -1.0  
 D, DA ISO m6  
 F, FA ISO h9

<sup>1)</sup> Dimensions for 4-pole motors also valid for 4/6- and 4-8 -pole two-speed motors.

<sup>2)</sup> Cooling distance.

<sup>3)</sup> Second shaft end on request.

Above dimensions are in mm.

For detailed drawings please see our web-pages 'www.abb.com/motors&drives' or contact us.

# General purpose steel motors

# Sizes 280-315

## Dimension drawings

Flange-mounted; IM B5 (IM 3001), V1 (IM 3011), V3 (IM 3031) and IM B14 (IM 3601), V18 (IM 3611), V19 (IM 3631)

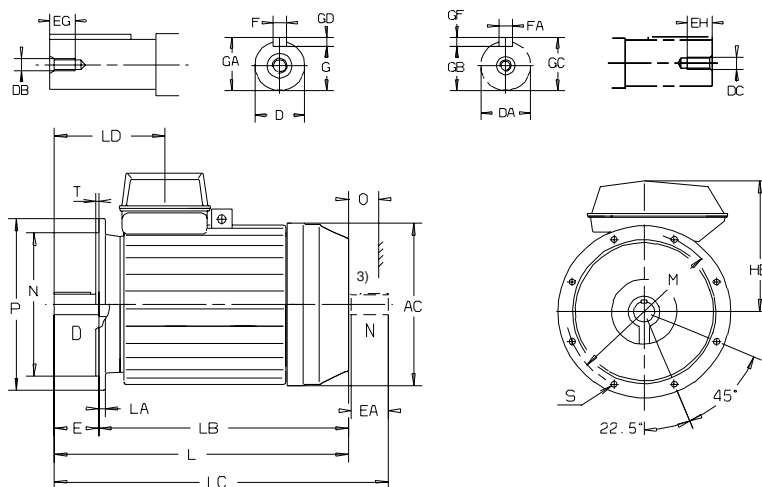

Motor size	Poles <sup>1)</sup>	AC	D	DA	DB	DC	E	EA	EG	EH	F	FA	G	GA	GB	GC
280 SA	2	555	65	60	M20	M20	140	140	40	40	18	18	58	69	53	64
	4-8	555	75	65	M20	M20	140	140	40	40	20	18	67.5	79.5	58	69
280 SMA	2	555	65	60	M20	M20	140	140	40	40	18	18	58	69	53	64
	4-8	555	75	65	M20	M20	140	140	40	40	20	18	67.5	79.5	58	69
280 MB	2	555	65	60	M20	M20	140	140	40	40	18	18	58	69	53	64
	4-8	555	75	65	M20	M20	140	140	40	40	20	18	67.5	79.5	58	69
280 MC,MD	2	555	65	60	M20	M20	140	140	40	40	18	18	58	69	53	64
	4-8	555	75	65	M20	M20	140	140	40	40	20	18	67.5	79.5	58	69
315 SA	2	624	65	60	M20	M20	140	140	40	40	18	18	58	69	53	64
	4-8	624	80	75	M20	M20	170	140	40	40	22	20	71	85	67.5	79.5
315 SMA	2	624	65	60	M20	M20	140	140	40	40	18	18	58	69	53	64
	4-8	624	80	75	M20	M20	170	140	40	40	22	20	71	85	67.5	79.5
315 MB	2	624	65	60	M20	M20	140	140	40	40	18	18	58	69	53	64
	4-8	624	80	75	M20	M20	170	140	40	40	22	20	71	85	67.5	79.5
315 LA	2	624	65	60	M20	M20	140	140	40	40	18	18	58	69	53	64
	4-8	624	90	75	M24	M20	170	140	48	40	25	20	81	95	67.5	79.5
315 LB,LC	2	624	65	60	M20	M20	140	140	40	40	18	18	58	69	53	64
	4-8	624	90	75	M24	M20	170	140	48	40	25	20	81	95	67.5	79.5

Motor size	Poles <sup>1)</sup>	GD	GF	HB	L	LA	LB	LC	LD	M	N	O <sup>2)</sup>	P	S	T
280 SA	2	11	11	450	1060	22	920	1210	385	500	450	100	550	18	5
	4-8	12	11	450	990	22	850	1140	385	500	450	100	550	18	5
280 SMA	2	11	11	450	1060	22	920	1210	385	500	450	100	550	18	5
	4-8	12	11	450	1060	22	920	1210	385	500	450	100	550	18	5
280 MB	2	11	11	450	1120	22	980	1270	385	500	450	100	550	18	5
	4-8	12	11	450	1120	22	980	1270	385	500	450	100	550	18	5
280 MC	2	11	11	450	1255	22	980	1405	385	500	450	100	550	18	5
	4-8	12	11	450	1255	22	980	1405	385	500	450	100	550	18	5
280 MD	2	11	11	450	1255	22	980	1405	385	500	450	100	550	18	5
	4-8	12	11	450	1255	22	980	1405	385	500	450	100	550	18	5
315 SA	2	11	11	505	1095	25	955	1245	390	600	550	115	660	23	6
	4-8	14	12	505	1125	25	955	1275	420	600	550	115	660	23	6
315 SMA	2	11	11	505	1195	25	1055	1345	390	600	550	115	660	23	6
	4-8	14	12	505	1125	25	955	1275	420	600	550	115	660	23	6
315 MB	2	11	11	505	1195	25	1055	1345	390	600	550	115	660	23	6
	4-8	14	12	505	1225	25	1055	1375	420	600	550	115	660	23	6
315 LA	2	11	11	505	1265	25	1125	1415	390	600	550	115	660	23	6
	4-8	14	12	505	1295	25	1125	1445	420	600	550	115	660	23	6
315 LB	2	11	11	505	1545	25	1125	1415	390	600	550	115	660	23	6
	4-8	14	12	505	1575	25	1405	1725	420	600	550	115	660	23	6
315 LC	2	11	11	505	1545	25	1125	1415	390	600	550	115	660	23	6
	4-8	14	12	526	1575	25	1405	1725	420	600	550	115	660	23	6

Tolerances:

D,DA ISO m6  
F, FA ISO h9  
N ISO j6

<sup>1)</sup> Dimensions for 4-pole motors also valid for 4/6- and 4-8 -pole two-speed motors.

<sup>2)</sup> Cooling distance.

<sup>3)</sup> Second shaft end on request.

Above dimensions are in mm.

For detailed drawings please see our web-pages '[www.abb.com/motors&drives](http://www.abb.com/motors&drives)' or contact us.

# General purpose steel motors

# Sizes 355-400

## Dimension drawings

Flange-mounted; IM B5 (IM 3001), V1 (IM 3011), V3 (IM 3031) and IM B14 (IM 3601), V18 (IM 3611), V19 (IM 3631)

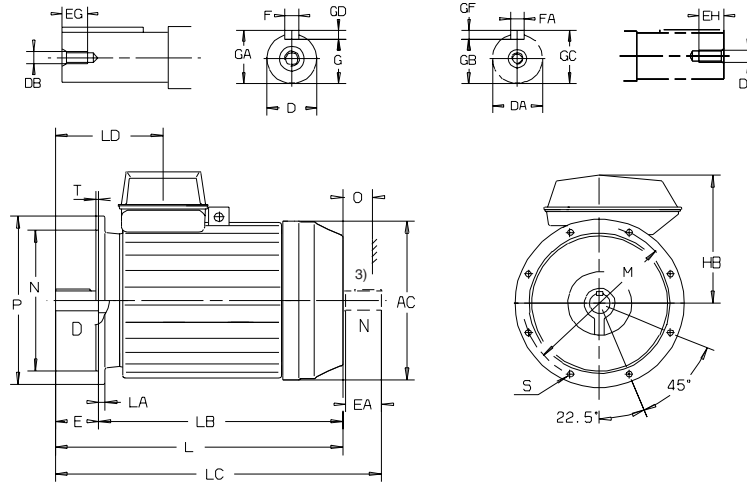

Motor size	Poles <sup>1)</sup>	AC	D	DA	DB	DC	E	EA	EG	EH	F	FA	G	GA	GB	GC
355 SA,SB	2	720	70	70	M20	M20	140	140	40	40	20	20	62.5	74.5	62.5	74.5
	4-8	720	100	90	M24	M24	210	170	48	48	28	25	90	106	81	95
355 MA	2	720	70	70	M20	M20	140	140	40	40	20	20	62.5	74.5	62.5	74.5
	4-8	720	100	90	M24	M24	210	170	48	48	28	25	90	106	81	95
355 MB	2	720	70	70	M20	M20	140	140	40	40	20	20	62.5	74.5	62.5	74.5
	4-8	720	100	90	M24	M24	210	170	48	48	28	25	90	106	81	95
355 LA	2	720	70	70	M20	M20	140	140	40	40	20	20	62.5	74.5	62.5	74.5
	4-8	720	100	90	M24	M24	210	170	48	48	28	25	90	106	81	95
355 LB	2	720	70	70	M20	M20	140	140	40	40	20	20	62.5	74.5	62.5	74.5
	4-8	720	100	90	M24	M24	210	170	48	48	28	25	90	106	81	95
355 LKD	4-8	720	100	90	M24	M24	210	170	48	48	28	25	90	106	81	95
400 MLA	2	810	70	70	M20	M20	140	140	40	40	20	20	62.5	74.5	62.5	74.5
	4-8	810	100	90	M24	M24	210	170	48	48	28	25	90	106	81	95
400 MLB	2	810	70	70	M20	M20	140	140	40	40	20	20	62.5	74.5	62.5	74.5
	4-8	810	100	90	M24	M24	210	170	48	48	28	25	90	106	81	95
400 LKA	2	810	80	75	M20	M20	170	140	40	40	22	20	71	85	67.5	79.5
	4-8	810	100	90	M24	M24	210	170	48	48	28	25	90	106	81	95
400 LKB	2	810	80	75	M20	M20	170	140	40	40	22	20	71	85	67.5	79.5
	4-8	810	100	90	M24	M24	210	170	48	48	28	25	90	106	81	95

Motor size	Poles <sup>1)</sup>	GD	GF	HB	L	LA	LB	LC	LD	M	N	O <sup>2)</sup>	P	S	T
355 SA,SB	2	12	12	565	1310	25	1170	1460	392	740	680	130	800	23	6
	4-8	16	14	565	1380	25	1170	1560	462	740	680	130	800	23	6
355 MA	2	12	12	565	1370	25	1230	1520	392	740	680	130	800	23	6
	4-8	16	14	565	1440	25	1230	1620	462	740	680	130	800	23	6
355 MB	2	12	12	565	1370	25	1230	1520	392	740	680	130	800	23	6
	4-8	16	14	565	1440	25	1230	1620	462	740	680	130	800	23	6
355 LA	2	12	12	565	1450	25	1310	1600	392	740	680	130	800	23	6
	4-8	16	14	565	1520	25	1310	1700	462	740	680	130	800	23	6
355 LB	2	12	12	565	1450	25	1310	1600	392	740	680	130	800	23	6
	4-8	16	14	565	1520	25	1310	1700	462	740	680	130	800	23	6
355 LKD	4-8	16	14	565	1660	25	1450	1847	462	740	680	130	800	23	6
400 MLA	2	12	12	603	1616	25	1476	1773	408	740	680	150	800	23	6
	4-8	16	14	603	1686	25	1476	1873	478	740	680	150	800	23	6
400 MLB	2	12	12	603	1616	25	1476	1773	408	740	680	150	800	23	6
	4-8	16	14	603	1686	25	1476	1873	478	740	680	150	800	23	6
400 LKA	2	14	12	603	1786	25	1616	1943	438	740	680	150	800	23	6
	4-8	16	14	603	1826	25	1616	2013	478	740	680	150	800	23	6
400 LKB	2	14	12	603	1786	25	1616	1943	438	740	680	150	800	23	6
	4-8	16	14	603	1826	25	1616	2013	478	740	680	150	800	23	6

Tolerances:

D,DA ISO m6  
F,FA ISO h9  
N ISO j6

<sup>1)</sup> Dimensions for 4-pole motors also valid for 4/6- and 4-8 -pole two-speed motors.

<sup>2)</sup> Cooling distance.

<sup>3)</sup> Second shaft end on request.

Above dimensions are in mm.

For detailed drawings please see our web-pages 'www.abb.com/motors&drives' or contact us.

# General purpose steel motors

# Sizes 280-315

## Dimension drawings

Foot- and flange-mounted; IM B35 (IM 2001), IM V15 (IM 2011), IM V36 (IM 2031) – terminal box top mounted

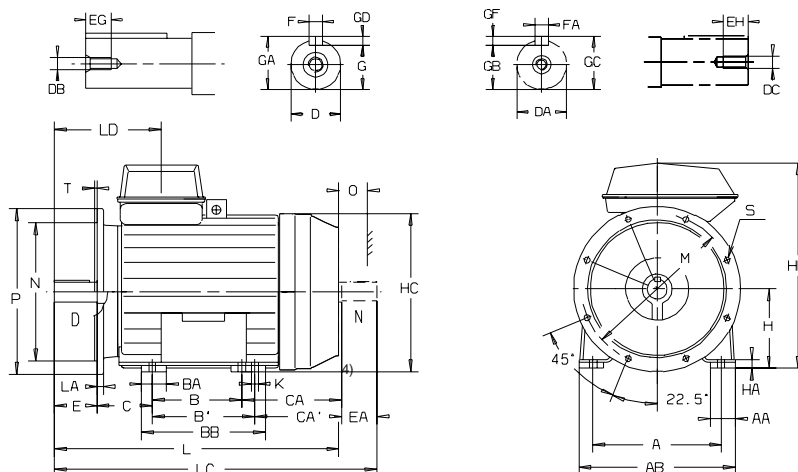

Motor size	Poles	A	AA	AB	B	B'	BA	BB	C	CA	CA'	D	DA	DB	DC	E	EA	EG	EH	F	FA
280 SA	2	457	80	545	368	—	100	501	190	372	—	65	60	M20	M20	140	140	40	40	18	18
	4-8	457	80	545	368	—	100	501	190	302	—	75	65	M20	M20	140	140	40	40	20	18
280 SMA	2	457	80	545	368	419	100	501	190	372	321	65	60	M20	M20	140	140	40	40	18	18
	4-8	457	80	545	368	419	100	501	190	372	321	75	65	M20	M20	140	140	40	40	20	18
280 MB	2	457	80	545	419	—	100	501	190	381	—	65	60	M20	M20	140	140	40	40	18	18
	4-8	457	80	545	419	—	100	501	190	381	—	75	65	M20	M20	140	140	40	40	20	18
280 MC,MD	2	457	80	545	419	—	100	501	190	381	—	65	60	M20	M20	140	140	40	40	18	18
	4-8	457	80	545	419	—	100	501	190	381	—	75	65	M20	M20	140	140	40	40	20	18
315 SA	2	508	100	622	406	—	100	539	216	343	—	65	60	M20	M20	140	140	40	40	18	18
	4-8	508	100	622	406	—	100	539	216	343	—	80	75	M20	M20	170	140	40	40	22	20
315 SMA	2	508	100	622	406	457	100	539	216	443	392	65	60	M20	M20	140	140	40	40	18	18
	4-8	508	100	622	406	457	100	539	216	343	292	80	75	M20	M20	170	140	40	40	22	20
315 MB	2	508	100	622	457	—	100	539	216	392	—	65	60	M20	M20	140	140	40	40	18	18
	4-8	508	100	622	457	—	100	539	216	392	—	80	75	M20	M20	170	140	40	40	22	20
315 LA	2	508	100	622	508	—	100	592	216	411	—	65	60	M20	M20	140	140	40	40	18	18
	4-8	508	100	622	508	—	100	592	216	411	—	90	75	M24	M20	170	140	48	40	25	20
315 LB,LC	2	508	100	622	508	—	100	592	216	411	—	65	60	M20	M20	140	140	40	40	18	18
	4-8	508	100	622	508	—	100	592	216	411	—	90	75	M24	M20	170	140	48	40	25	20

Motor size	Poles	G	GA	GB	GC	GD	GF	H	HA	HC	HD	K	L	LC	LD	M	N	O	P	S	T
280 SA	2	58	69	53	64	11	11	280	32	558	730	24	1060	1210	385	500	450	100	550	18	5
	4-8	67.5	79.5	58	69	12	11	280	32	558	730	24	990	1140	385	500	450	100	550	18	5
280 SMA	2	58	69	53	64	11	11	280	32	558	730	24	1060	1210	385	500	450	100	550	18	5
	4-8	67.5	79.5	58	69	12	11	280	32	558	730	24	1060	1210	385	500	450	100	550	18	5
280 MB	2	58	69	53	64	11	11	280	32	558	730	24	1120	1270	385	500	450	100	550	18	5
	4-8	67.5	79.5	58	69	12	11	280	32	558	730	24	1120	1270	385	500	450	100	550	18	5
280 MC	2	58	69	53	64	11	11	280	32	558	730	24	1255	1405	385	500	450	100	550	18	5
	4-8	67.5	79.5	58	69	12	11	280	32	558	730	24	1225	1405	385	500	450	100	550	18	5
280 MD	2	58	69	53	64	11	11	280	32	558	730	24	1255	1405	385	500	450	100	550	18	5
	4-8	67.5	79.5	58	69	12	11	280	32	558	730	24	1255	1405	385	500	450	100	550	18	5
315 SA	2	58	69	53	64	11	11	315	32	627	820	28	1095	1245	390	600	550	115	660	23	6
	4-8	71	85	67.5	79.5	14	12	315	32	627	820	28	1125	1275	420	600	550	115	660	23	6
315 SMA	2	58	69	53	64	11	11	315	32	627	820	28	1195	1345	390	600	550	115	660	23	6
	4-8	71	85	67.5	79.5	14	12	315	32	627	820	28	1125	1275	420	600	550	115	660	23	6
315 MB	2	58	69	53	64	11	11	315	32	627	820	28	1195	1345	390	600	550	115	660	23	6
	4-8	71	85	67.5	79.5	14	12	315	32	627	820	28	1225	1375	420	600	550	115	660	23	6
315 LA	2	58	69	53	64	11	11	315	32	627	820	28	1265	1415	390	600	550	115	660	23	6
	4-8	81	95	67.5	79.5	14	12	315	32	627	820	28	1295	1445	420	600	550	115	660	23	6
315 LB	2	58	69	53	64	11	11	315	32	627	820	28	1545	1695	390	600	550	115	660	23	6
	4-8	81	95	67.5	79.5	14	12	315	32	627	820	28	1575	1725	420	600	550	115	660	23	6
315 LC	2	58	69	53	64	11	11	315	32	627	848	28	1545	1695	390	600	550	115	660	23	6
	4	81	95	67.5	79.5	14	12	315	32	627	848	28	1575	1725	420	600	550	115	660	23	6
	6	81	95	67.5	79.5	14	12	315	32	627	820	28	1575	1725	420	600	550	115	660	23	6

Tolerances:

A, B ISO js14  
D, DA ISO m6  
F, FA ISO h9

<sup>1)</sup> Dimensions for 4-pole motors also valid for 4/6- and 4-8-pole two-speed motors.  
<sup>2)</sup> Cooling distance.  
<sup>3)</sup> Second shaft end on request.

Above dimensions are in mm.  
For detailed drawings please see our web-pages 'www.abb.com/motors&drives' or contact us.

# General purpose steel motors

# Sizes 280-315

## Dimension drawings

Foot- and flange-mounted; IM B35 (IM 2001), IM V15 (IM 2011), IM V36 (IM 2031) – terminal box side mounted

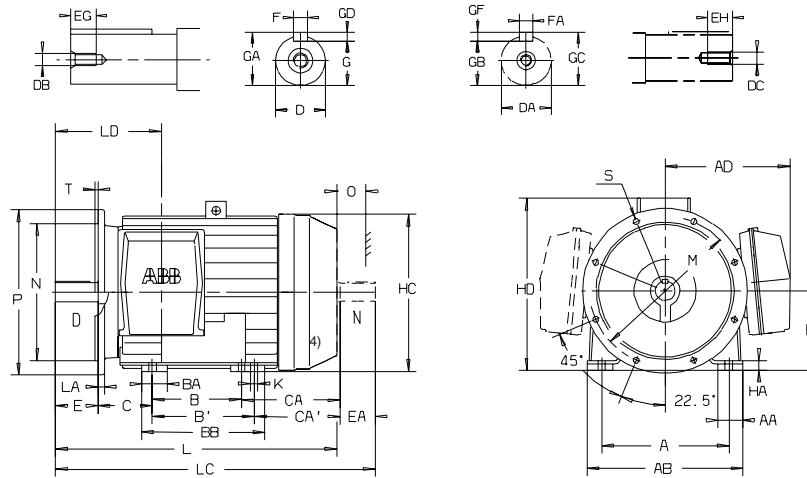

Motor size	Poles A <sup>1)</sup>	AA	AB	AD	B	B'	BA	BB	C	CA	CA'	D	DA	DB	DC	E	EA	EG	EH	F	FA	
280 SA	2	457	80	545	448	368	–	100	501	190	372	–	65	60	M20	M20	140	140	40	40	18	18
	4-8	457	80	545	448	368	–	100	501	190	302	–	75	65	M20	M20	140	140	40	40	20	18
280 SMA	2	457	80	545	448	368	419	100	501	190	372	321	65	60	M20	M20	140	140	40	40	18	18
	4-8	457	80	545	448	368	419	100	501	190	372	321	75	65	M20	M20	140	140	40	40	20	18
280 MB	2	457	80	545	448	419	–	100	501	190	381	–	65	60	M20	M20	140	140	40	40	18	18
	4-8	457	80	545	448	419	–	100	501	190	381	–	75	65	M20	M20	140	140	40	40	20	18
280 MC,MD2	2	457	80	545	448	419	–	100	501	190	381	–	65	60	M20	M20	140	140	40	40	18	18
	4-8	457	80	545	448	419	–	100	501	190	381	–	75	65	M20	M20	140	140	40	40	20	18
315 SA	2	508	100	622	502	406	–	100	539	216	343	–	65	60	M20	M20	140	140	40	40	18	18
	4-8	508	100	622	502	406	–	100	539	216	343	–	80	75	M20	M20	170	140	40	40	22	20
315 SMA	2	508	100	622	502	406	457	100	539	216	443	392	65	60	M20	M20	140	140	40	40	18	18
	4-8	508	100	622	502	406	457	100	539	216	343	292	80	75	M20	M20	170	140	40	40	22	20
315 MB	2	508	100	622	502	457	–	100	539	216	392	–	65	60	M20	M20	140	140	40	40	18	18
	4-8	508	100	622	502	457	–	100	539	216	392	–	80	75	M20	M20	170	140	40	40	22	20
315 LA	2	508	100	622	502	508	–	100	592	216	411	–	65	60	M20	M20	140	140	40	40	18	18
	4-8	508	100	622	502	508	–	100	592	216	411	–	90	75	M24	M20	170	140	48	40	25	20
315 LB,LC	2	508	100	622	502	508	–	100	592	216	411	–	65	60	M20	M20	140	140	40	40	18	18
	4-8	508	100	622	502	508	–	100	592	216	411	–	90	75	M24	M20	170	140	48	40	25	20

Motor size	Poles G <sup>1)</sup>	GA	GB	GC	GD	GF	H	HA	HC	HD	K	L	LC	LD	M	N	O <sup>2)</sup>	P	S	T	
280 SA	2	58	69	53	64	11	11	280	32	558	620	24	1060	1210	385	500	450	100	550	18	5
	4-8	67.5	79.5	58	69	12	11	280	32	558	620	24	990	1140	385	500	450	100	550	18	5
280 SMA	2	58	69	53	64	11	11	280	32	558	620	24	1060	1210	385	500	450	100	550	18	5
	4-8	67.5	79.5	58	69	12	11	280	32	558	620	24	1060	1210	385	500	450	100	550	18	5
280 MB	2	58	69	53	64	11	11	280	32	558	620	24	1120	1270	385	500	450	100	550	18	5
	4-8	67.5	79.5	58	69	12	11	280	32	558	620	24	1120	1270	385	500	450	100	550	18	5
280 MC	2	58	69	53	64	11	11	280	32	558	620	24	1255	1405	385	500	450	100	550	18	5
	4-8	67.5	79.5	58	69	12	11	280	32	558	620	24	1255	1405	385	500	450	100	550	18	5
280 MD	2	58	69	53	64	11	11	280	32	558	620	24	1255	1405	385	500	450	100	550	18	5
	4-8	67.5	79.5	58	69	12	11	280	32	558	620	24	1255	1405	385	500	450	100	550	18	5
315 SA	2	58	69	53	64	11	11	315	32	627	685	28	1095	1245	390	600	550	115	660	23	6
	4-8	71	85	67.5	79.5	14	12	315	32	627	685	28	1125	1275	420	600	550	115	660	23	6
315 SMA	2	58	69	53	64	11	11	315	32	627	685	28	1195	1345	390	600	550	115	660	23	6
	4-8	71	85	67.5	79.5	14	12	315	32	627	685	28	1125	1275	420	600	550	115	660	23	6
315 MB	2	58	69	53	64	11	11	315	32	627	685	28	1195	1345	390	600	550	115	660	23	6
	4-8	71	85	67.5	79.5	14	12	315	32	627	685	28	1225	1375	420	600	550	115	660	23	6
315 LA	2	58	69	53	64	11	11	315	32	627	685	28	1265	1415	390	600	550	115	660	23	6
	4-8	81	95	67.5	79.5	14	12	315	32	627	685	28	1295	1445	420	600	550	115	660	23	6
315 LB,LC	2	58	69	53	64	11	11	315	32	627	685	28	1545	1695	390	600	550	115	660	23	6
	4-8	81	95	67.5	79.5	14	12	315	32	627	685	28	1575	1725	420	600	550	115	660	23	6

Tolerances:

A, B ISO js14 H ISO 0, -1.0  
D, DA ISO m6 N ISO j6  
F, FA ISO h9

<sup>1)</sup> Dimensions for 4-pole motors also valid for 4/6- and 4-8-pole two-speed motors.

<sup>2)</sup> Cooling distance.

<sup>3)</sup> Second shaft end on request.

Above dimensions are in mm.

For detailed drawings please see our web-pages 'www.abb.com/motors&drives' or contact us.





# General purpose steel motors

# Sizes 355-400

## Dimension drawings

Foot- and flange-mounted; IM B35 (IM 2001), IM V15 (IM 2011), IM V36 (IM 2031) – terminal box side mounted

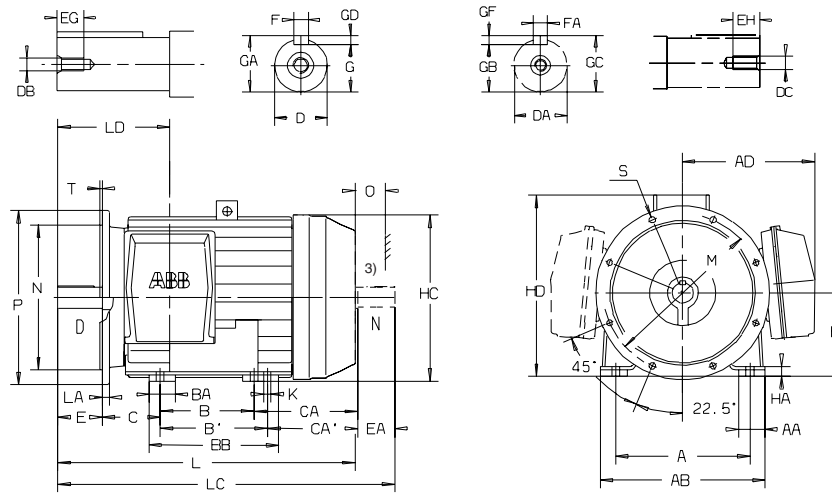

Motor size	Poles <sup>1)</sup>	A	AA	AB	AD	B	B'	BA	BB	C	CA	CA'	D	DA	DB	DC	E	EA	EG	EH	F	FA
355 SA,SB	2	610	110	714	570	500	–	100	584	254	416	–	70	70	M20	M20	140	140	40	40	20	20
	4-8	610	110	714	570	500	–	100	584	254	416	–	100	90	M24	M20	210	170	48	48	28	25
355 MA	2	610	110	714	570	560	–	100	644	254	416	–	70	70	M20	M20	140	140	40	40	20	20
	4-8	610	110	714	570	560	–	100	644	254	416	–	100	90	M24	M24	210	170	48	48	28	25
355 MB	2	610	110	714	570	560	–	100	644	254	416	–	70	70	M20	M20	140	140	40	40	20	20
	4-8	610	110	714	570	560	–	100	644	254	416	–	100	90	M24	M24	210	170	48	48	28	25
355 LA	2	610	110	714	570	630	–	100	765	254	426	–	70	70	M20	M20	140	140	40	40	20	20
	4-8	610	110	714	570	630	–	100	765	254	426	–	100	90	M24	M24	210	170	48	48	28	25
355 LB	2	610	110	714	570	630	–	100	765	254	426	–	70	70	M20	M20	140	140	40	40	20	20
	4-8	610	110	714	570	630	–	100	765	254	426	–	100	90	M24	M24	210	170	48	48	28	25
355 LKD	4-8	610	110	714	570	630	710	100	802	254	583	503	100	90	M24	M24	210	170	48	48	28	25
400 MLA	2	686	140	820	603	630	710	140	850	280	583	503	70	70	M20	M20	140	140	40	40	20	20
	4-8	686	140	820	603	630	710	140	850	280	583	503	100	90	M24	M24	210	170	48	48	28	25
400 MLB	2	686	140	820	603	630	710	140	850	280	583	503	70	70	M20	M20	140	140	40	40	20	20
	4-8	686	140	820	603	630	710	140	850	280	583	503	100	90	M24	M24	210	170	48	48	28	25
400 LKA	2	686	140	820	603	710	800	140	935	280	643	553	80	75	M20	M20	170	140	40	40	22	20
	4-8	686	140	820	603	710	800	140	935	280	643	553	100	90	M24	M24	210	170	48	48	28	25
400 LKB	2	686	140	820	603	710	800	140	935	280	643	553	80	75	M20	M20	170	140	40	40	22	20
	4-8	686	140	820	603	710	800	140	935	280	643	553	100	90	M24	M24	210	170	48	48	28	25

Motor size	Poles <sup>1)</sup>	G	GA	GB	GC	GD	GF	H	HA	HC	HD	K	L	LC	LD	M	N	O <sup>2)</sup>	P	S	T
355 SA,SB	2	62.5	74.5	62.5	74.5	12	12	355	36	715	768	28	1310	1460	392	740	680	130	800	23	6
	4-8	90	106	81	95	16	14	355	36	715	768	28	1380	1560	462	740	680	130	800	23	6
355 MA	2	62.5	74.5	62.5	74.5	12	12	355	36	715	768	28	1370	1520	392	740	680	130	800	23	6
	4-8	90	106	81	95	16	14	355	36	715	768	28	1440	1620	462	740	680	130	800	23	6
355 MB	2	62.5	74.5	62.5	74.5	12	12	355	36	715	768	28	1370	1520	392	740	680	130	800	23	6
	4-8	90	106	81	95	16	14	355	36	715	768	28	1440	1620	462	740	680	130	800	23	6
355 LA	2	62.5	74.5	62.5	74.5	12	12	355	36	715	768	28	1450	1600	392	740	680	130	800	23	6
	4-8	90	106	81	95	16	14	355	36	715	768	28	1520	1700	462	740	680	130	800	23	6
355 LB	2	62.5	74.5	62.5	74.5	12	12	355	36	715	768	28	1450	1600	392	740	680	130	800	23	6
	4-8	90	106	81	95	16	14	355	36	715	768	28	1520	1700	462	740	680	130	800	23	6
355 LKD	4-8	90	106	91	95	16	14	355	36	715	768	28	1660	1847	462	740	680	130	800	23	6
400 MLA	2	62.5	74.5	62.5	74.5	12	12	400	45	805	900	35	1616	1773	408	740	680	150	800	23	6
	4-8	90	106	81	95	16	14	400	45	805	900	35	1686	1873	478	740	680	150	800	23	6
400 MLB	2	62.5	74.5	62.5	74.5	12	12	400	45	805	900	35	1616	1773	408	740	680	150	800	23	6
	4-8	90	106	81	95	16	14	400	45	805	900	35	1686	1873	478	740	680	150	800	23	6
400 LKA	2	71	85	67.5	79.5	14	12	400	45	805	900	35	1786	1943	438	740	680	150	800	23	6
	4-8	90	106	81	95	16	14	400	45	805	900	35	1826	2013	478	740	680	150	800	23	6
400 LKB	2	71	85	67.5	79.5	14	12	400	45	805	900	35	1786	1943	438	740	680	150	800	23	6
	4-8	90	106	81	95	16	14	400	45	805	900	35	1826	2013	478	740	680	150	800	23	6

Tolerances:

A, B ISO js14 H ISO 0, -1.0  
 D, DA ISO m6 N ISO j6  
 F, FA ISO h9

<sup>1)</sup> Dimensions for 4-pole motors also valid for 4/6- and 4-8 -pole two-speed motors.

<sup>2)</sup> Cooling distance.

<sup>3)</sup> Second shaft end on request.

Above dimensions are in mm.  
 For detailed drawings please see our web-pages 'www.abb.com/motors&drives' or contact us.

# General purpose steel motors

# Sizes 280-400

## Dimension drawings

### Terminal box in standard design with 6 terminals

#### Top-mounted terminal box:

122/4  
142/4

162/4, 162/9 +  
adapter

#### Side-mounted terminal box:

122/5  
142/6  
162/7, 162/10

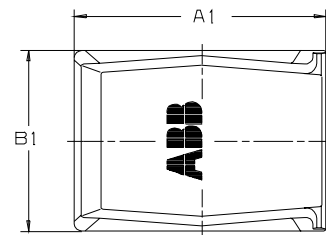
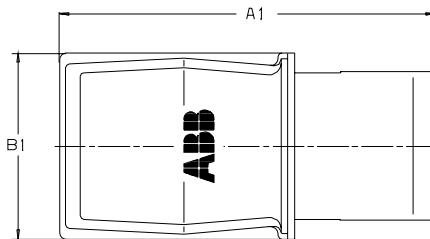
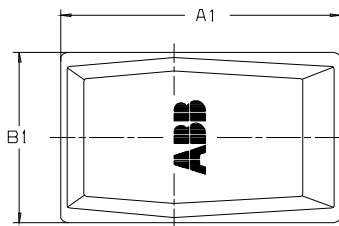
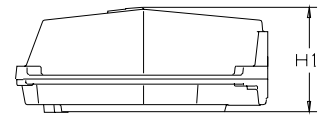
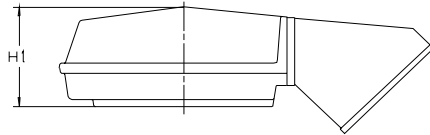
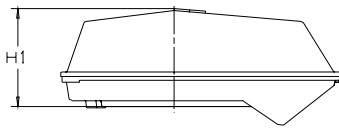

Terminal box type	Motor size	A1	B1	H1
-------------------	------------	----	----	----

#### Top-mounted terminal box:

122/4	280	455	280	177
142/4	315 - 400M	536	349	197
162/4 + adapter	355 - 400	787	410	226

#### Side-mounted terminal box:

122/5	280	383	280	180
142/6	315 - 400M	426	347	201
162/7	355 - 400	508	412	226

For motor dimensions please see dimension drawings on earlier pages.

Further details on terminal boxes on previous pages.

## Rating plate

The rating plate is in table form giving values for speed, current and power factor for six voltages.

ABB Oy, Electrical Machines LV Motors, Vaasa, Finland						
CE						
3 ~ Motor M2CA 315 SMA 4 B3						
IEC 315 S/M 80						
No. 0320-010119452						
Ins.cl.			F	IP		55
V	Hz	kW	r/min	A	cos φ	Duty
690 Y	50	132	1486	138	0,85	S1
400 D	50	132	1486	232	0,85	S1
660 Y	50	132	1485	141	0,86	S1
380 D	50	132	1485	245	0,86	S1
415 D	50	132	1487	232	0,84	S1
440 D	60	150	1784	238	0,87	S1
Prod.code 3GCA312310-ADA						
			Nmax		r/min	
6319/C3			6316/C3		730 kg	
ABB IEC 60034-1						

# Accessories

## Slide rails for motor sizes 280-400

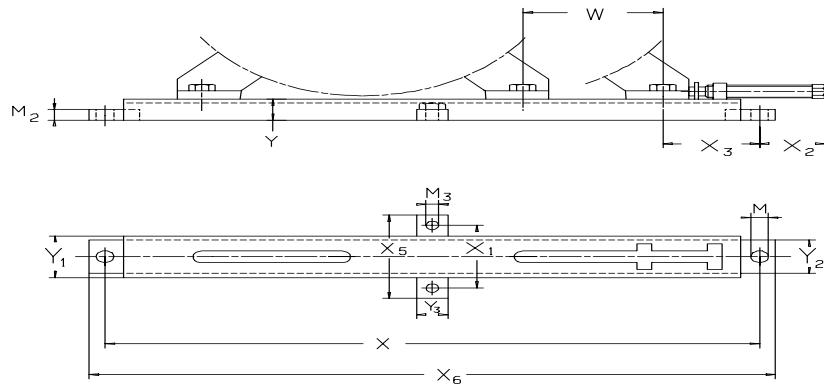

Type	Motor size	M	M <sub>2</sub>	M <sub>3</sub>	W <sub>max</sub>	X	X <sub>1</sub>	X <sub>2</sub> max	X <sub>3</sub> min	X <sub>5</sub>	X <sub>6</sub>	Y	Y <sub>1</sub>	Y <sub>2</sub>	Y <sub>3</sub>	Weight/rail kg
ZHKJ 50	280	28	25	20	135	850	150	125	135	200	900	50	100	80	50	14.5
ZHKJ 63	315	28	25	20	220	1040	150	125	150	200	1090	50	100	80	50	17.5
ZHKJ 71 <sup>1)</sup>	355	33	30	20	275	1260	190	145	185	240	1320	60	140	120	50	31
ZHKJ 71 <sup>1)</sup>	400	33	30	20	180	1260	190	140	200	240	1320	60	140	120	50	31

<sup>1)</sup> When mounting on a ceiling or on a wall please contact the manufacturer.

Each set includes two complete slide rails including screw for mounting the motor on the rails. Screws for mounting the rails on the foundation are not included. Slide rails are supplied with unmachined lower surfaces and should, prior to tightening down, be supported in a suitable manner.

## Foundation studs for motor sizes 280-400

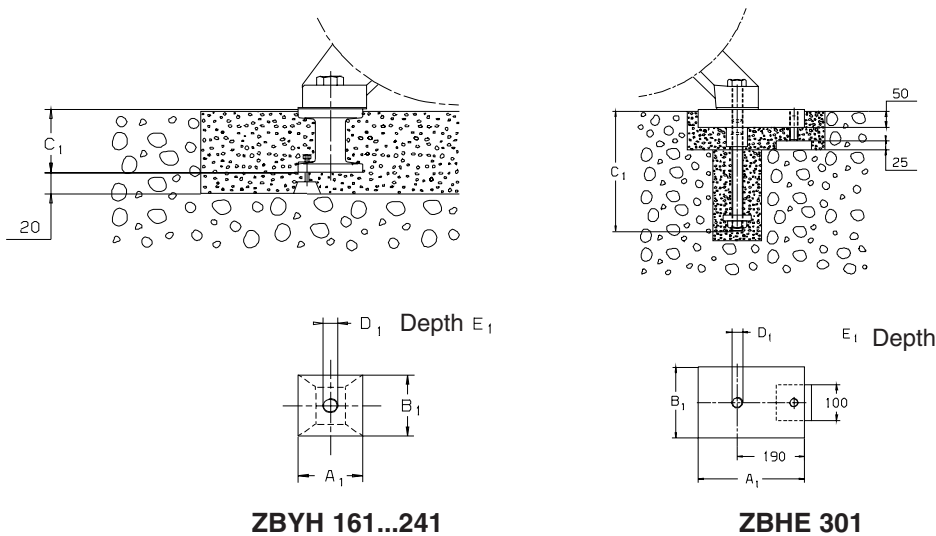

ZBYH 161...241

ZBHE 301

Foundation stud type	Fixing screw	Motor size	Main dimensions A1	B1	C1	D1	E1	Weight kg
ZBYH 201	M20 x 70/70 Y	280	100	100	95	M20	35	3.4
ZBYH 241	M24 x 90/90 Y	315, 355	130	130	135	M24	45	7
ZBHE 301	M30 x 100/100 Y	400	300	200	385	M30	65	30

Each set of foundation studs includes 4 studs, fixing screw for the motor, adjusting screw with foundation plate.

# Accessories

## Protective roof (variant code 005)

Motor size	Poles	Ø	L
280 S_	2	555	1160
	4-12	555	1090
280 SM_	2	555	1160
	4-12	555	1160
280 M_	2	555	1220
	4-12	555	1220
315 S_	2	624	1210
	4-12	624	1240
315 SM_	2	624	1310
	4-12	624	1240
315 M_	2	624	1310
	4-12	624	1340
315 L_	2	624	1380
	4-12	624 <td 1410	
355 S_	2	720	1440
	4-12	720	1510
355 M_	2	720	1500
	4-12	720	1570
355 L_	2	720	1580
	4-12	720	1650
355 LK_	4-12	720	1790
	4-12	810	1796
400 ML_	2	810	1836
	4-12	810	1936
400 LK_	2	810	1936
	4-12	810	1976

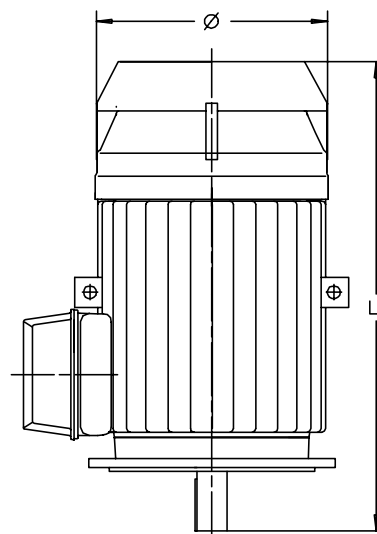

Mounting arrangement IM V1  
with protective roof

## Silencer for motor sizes 280-400

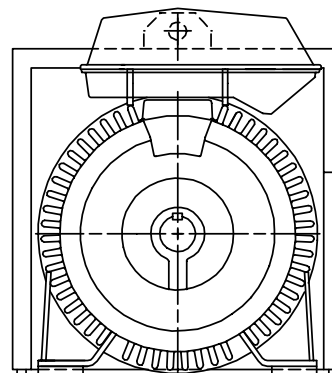
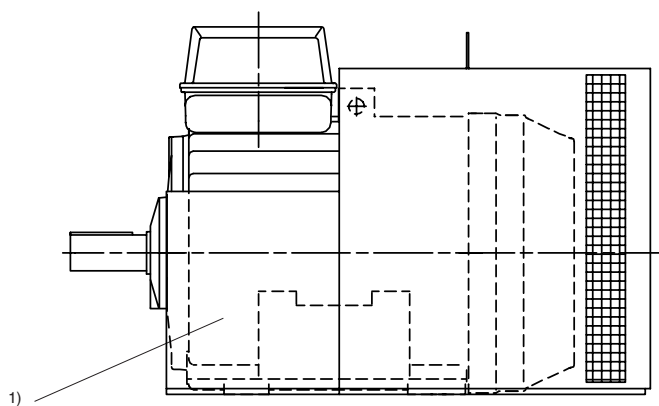

Both foot-mounted and flange-mounted motors can be fitted with a silencer to reduce the noise level by about 10 dB(A). The silencer is painted blue and is made of 2 mm steel sheet. The sound absorbing material is 40 mm thick polyurethane foam. On the underside there is a rubber strip to seal against the floor. The silencer fits loosely over the motor.

**Dimensions of silencers on request.**

<sup>1)</sup> If connections to the motor or control gear require it, an opening can be made in the extension of the silencer or it can be removed.

# General purpose steel motors in brief, basic design

Motor frame size		280	315	355	400
<b>Stator</b>	Material Paint colour shade Paint thickness	Profile-pressed sheet steel Blue, Munsell 8B 4.5/3.25 (NCS 4822-B05G) Two-pack epoxy paint, thickness $\geq 70 \mu\text{m}$			
<b>Bearing end shields</b>	Material Paint colour shade Paint thickness	Cast iron EN-GJL-200 or spheroidal graphit EN-GJS-400 Blue, Munsell 8B 4.5/3.25 (NCS 4822-B05G) Two-pack epoxy paint, thickness $\geq 70 \mu\text{m}$			
<b>Bearings</b>	D-end      2-pole 4-12 poles	6316/C4 6316/C3	6316/C4 6319/C3	6316M/C4 6322/C3	6317M/C4 6322/C3
	N-end      2-pole 4-12 poles	6316/C4 6316/C3	6316/C4 6316/C3	6316M/C4 6319/C3	6317M/C4 6319/C3
<b>Axially-locked bearings</b>	Inner bearing cover	As standard, locked at D-end			
<b>Bearing seal</b>		V-ring as standard, radial seal on request			
<b>Lubrication</b>		Regreasing nipples, M10x1 Grease for bearing temperatures $-30^{\circ}\text{C}$ to $+120^{\circ}\text{C}$			
<b>SPM-nipples</b>		On request			
<b>Rating plate</b>		Acid proof stainless steel AISI 316, thickness 0.6 mm, with individual serial number			
<b>Terminal box</b>	Frame material Cover material Cover screw material	Cast iron EN-GJL-150 Cast iron EN-GJL-150 Steel 5G, coated with zinc and yellow cromated			
<b>Connections</b>	Cable      2, 4 pole entries      6 pole	2 x Pg42 2 x Pg36	2 x Pg48 2 x Pg42	2 x Ø60/80 2 x Ø60	2 x Ø80 2 x Ø60/80
	Terminals	6 terminals for connection with cable lugs (not included)			
<b>Fan</b>	Material	Reinforced glassfiber laminate, aluminium or polypropylene with metal hub			
<b>Fan cover</b>	Material Paint colour shade Paint thickness	Sheet steel Blue, Munsell 8B 4.5/3.25 (NCS 4822-B05G) Two-pack epoxy polyester paint, thickness $\geq 80 \mu\text{m}$			
<b>Stator winding</b>	Material Insulation	Copper Insulation class F; temperature rise class B unless otherwise stated.			
	Winding protection	PTC-thermistors $150^{\circ}\text{C}$ , 3 in series, as standard			
<b>Rotor winding</b>	Material	Pressure die-cast aluminium			
<b>Balancing method</b>		Half key balancing as standard			
<b>Key way</b>		Open key way			
<b>Heating elements</b>	On request	50 W	1 x 65 W	2 x 65 W	2 x 65 W
<b>Drain holes</b>		As standard, open on delivery			
<b>Enclosure</b>		IP 55, higher protection on request			
<b>Cooling method</b>		IC 411			





# Drive<sup>IT</sup> General Purpose Cast Iron Motors

Totally enclosed squirrel cage three phase low voltage motors,

Sizes 71 - 355, 0.25 to 250 kW

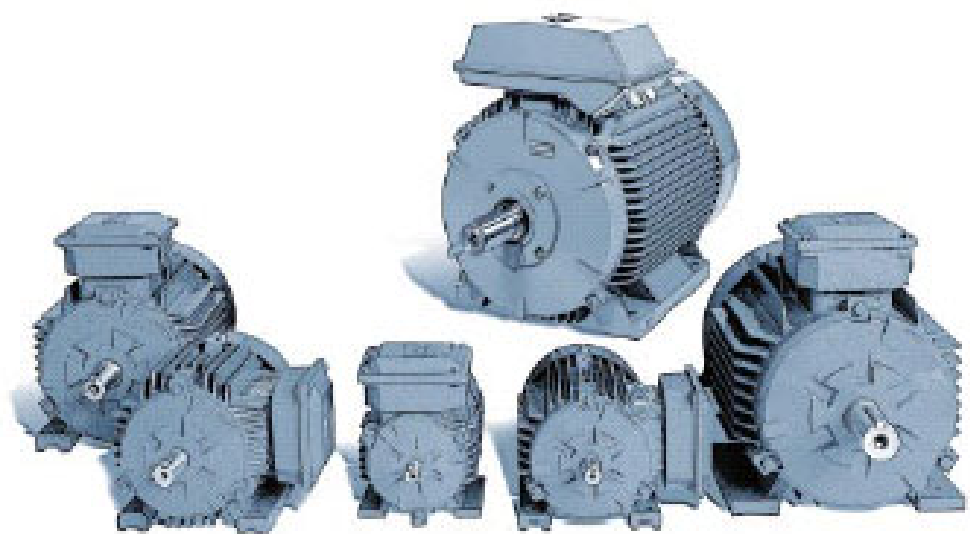

4

<b>Mechanical design.....</b>	<b>112</b>
<b>Ordering information.....</b>	<b>119</b>
<b>Technical data.....</b>	<b>120</b>
<b>Variant codes.....</b>	<b>128</b>
<b>Dimension drawings.....</b>	<b>131</b>
<b>Rating plates.....</b>	<b>140</b>
<b>Construction.....</b>	<b>141</b>
<b>Cast iron motors in brief.....</b>	<b>142</b>

# Mechanical design

## Stator

The motor frame including feet, bearing housing and terminal box is made of cast iron. Integrally cast feet allow a very rigid mounting and minimal vibration.

Motors can be supplied for foot mounting, flange mounting and combinations of these.

## Drain holes

Motors, frame sizes 280 to 355, are fitted with drain holes and closable plugs. The plugs are open on delivery. When mounting the motors, ensure that the drain holes face downwards.

In the case of vertical mounting, the upper plug must be hammered home completely. In very dusty environments, both plugs should be hammered home.

Drain holes for motors IEC frame sizes 71 to 250 are available as modification.

Drain holes for motors IEC-frame sizes 280 to 355

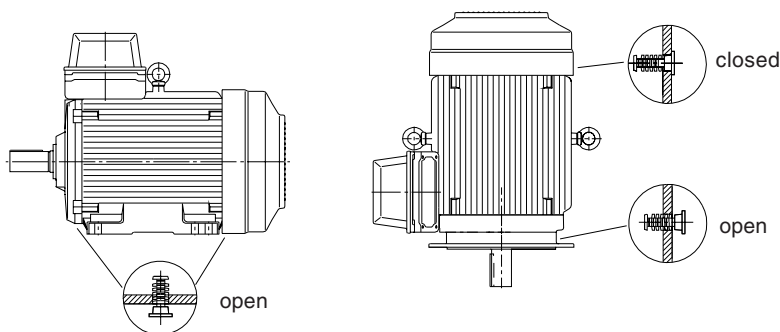

## Terminal boxes

Terminal boxes are mounted on top of the motor as standard. The terminal box can also be mounted on the left or right side, see ordering information.

Terminations are suitable for Cu- and Al-cables. Cables are connected to the terminals by cable lugs which are not included with the motor.

The terminal box of motor sizes 71 to 250 can be turned 4x90° and in motors sizes 280 to 355 rotated 2x180°, to allow cable entry from either side of the motor.

To enable the supply of suitable terminations for the motor, please state cable type, quantity and size when ordering. Non-standard design of terminal boxes; e.g. size, degree of protection, are available as options.

Degree of protection of standard terminal box is IP 55.

Please see variant codes for options.

The terminal boxes in sizes 280 to 355 are equipped with cable glands or cable boxes as standard.

### Terminal box examples

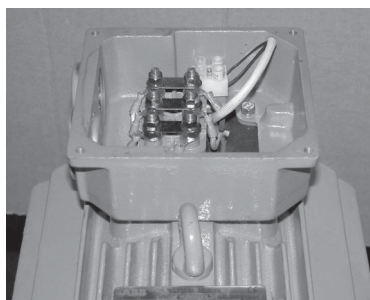

Motor sizes 71 to 132

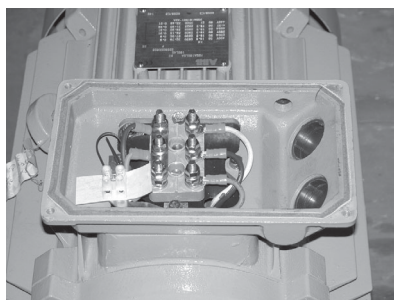

Motor sizes 160 to 250

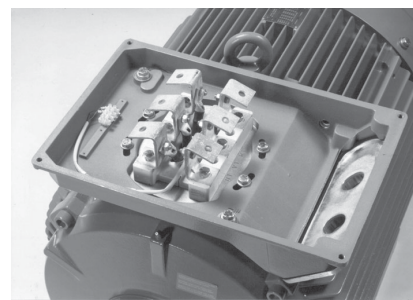

Motor sizes 280 to 355, provided either with a cable gland or a cable box.



## Terminal boxes and cable entries

If no ordering information of the cable is given, it is assumed to be p.v.c.-insulated and termination parts are supplied according to the table below.

In motor sizes 280 to 355 the terminal box is equipped with cable glands or cable boxes as standard.

To enable the supply of suitable terminations for the motor, please state cable type, quantity and size when ordering.

The table below shows the different alternatives available for cable boxes and cable entries. Other types on request.

### Cast iron motor sizes 71 to 250 with top-mounted terminal box

Motor size	Poles	Cable entry mm
71M	2,4,6	2xM16x1.5
80M	2,4,6	2xM25x1.5
90S	2,4,6	2xM25x1.5
90L	2,4,6	2xM25x1.5
100L	2,4,6,8	2xM32x1.5
112M	2,4,6,8	2xM32x1.5
132S	2,4,6,8	2xM32x1.5
132M	2,4,6,8	2xM32x1.5

Motor size	Poles	Cable entry mm
160M	2,4,6,8	2xM40x1.5
160L	2,4,6,8	2xM40x1.5
180M	2,4,6,8	2xM40x1.5
180L	2,4,6,8	2xM40x1.5
200L	2,4,6,8	2xM50x1.5
225S	4,6,8	2xM50x1.5
225M	2,4,6,8	2xM50x1.5
250M	2,4,6,8	2xM63x1.5

Cable entries for thermistors: 1xM16x1.5 (type 160 to 250)

### Cast iron motor sizes 280 to 355 with top-mounted terminal box

Motor size	Terminal box	Flange	Cable gland	Cable entry	Cable diameter	Auxiliary entries	Terminal bolt
<b>3000 r/min (2 poles)</b>							
280 SM_	122/2	3GZF 294 730-749	3GZF 294 730-613	2 x M63	2 x Ø32-49	2 x M20	M8
315 SM_, ML_	142/1	3GZF 294 730-753	3GZF 294 730-613	2 x M63	3 x Ø32-49	2 x M20	M10
355 S	162/1	3GZF 294 730-753	3GZF 294 730-613	2 x M63	3 x Ø32-49	2 x M20	M12
<b>1500 r/min (4 poles)</b>							
280 SM_	122/2	3GZF 294 730-749	3GZF 294 730-613	2 x M63	2 x Ø32-49	2 x M20	M8
315 SM_, ML_	142/1	3GZF 294 730-753	3GZF 294 730-613	2 x M63	3 x Ø32-49	2 x M20	M10
355 S	162/1	3GZF 294 730-753	3GZF 294 730-613	2 x M63	3 x Ø32-49	2 x M20	M12
<b>1000 r/min (6 poles)</b>							
280 SM_	122/2	3GZF 294 730-749	3GZF 294 730-613	2 x M63	2 x Ø32-49	2 x M20	M8
315 SM_, ML_	142/1	3GZF 294 730-753	3GZF 294 730-613	2 x M63	3 x Ø32-49	2 x M20	M10
355 S	142/2	3GZF 294 730-753	3GZF 294 730-613	2 x M63	3 x Ø32-49	2 x M20	M10
<b>750 r/min (8 poles)</b>							
280 SM_	122/2	3GZF 294 730-749	3GZF 294 730-613	2 x M63	2 x Ø32-49	2 x M20	M8
315 SM_, ML_	142/1	3GZF 294 730-753	3GZF 294 730-613	2 x M63	3 x Ø32-49	2 x M20	M10
355 S	142/2	3GZF 294 730-753	3GZF 294 730-613	2 x M63	3 x Ø32-49	2 x M20	M10

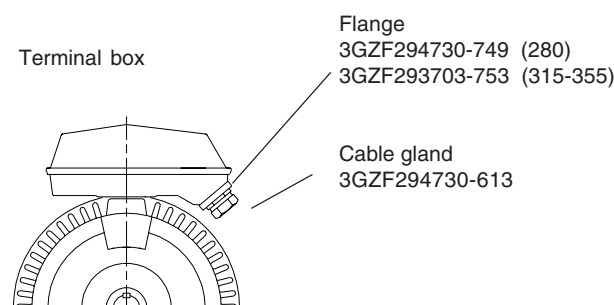

## Alternatives for cable entries and cable boxes for motor sizes 280 to 355

Motor size	Terminal box on top	Terminal box on side	Opening type (D/Y-conn.)	Max. rated current A	Max connection cable area	Cable gland diameter	Auxiliary cable entries	Cable box diameter	Blank plate
280	122/2	NA	C (FL 21)	363/210	2 x 150	2 x M40-63	2 x M20	max 2xØ60	MKLN 20
315	142/1	NA	D (FL33)	640/370	2 x 240	1 x M40-63	2 x M20	max 2xØ60	MKLN 30
355	142/2		D (FL33)	640/370	2 x 240	2 x M40-63	2 x M20	max 2xØ80	
	162/1		E-D	950/550	4 x 240			max 4xØ60	

### Flange

Opening	c	e	f	g	d
C (FL 21)	62	193	62	193	M8
D (FL 33)	100	300	80	292	M10
E (FL 40)	115	370	100	360	M12

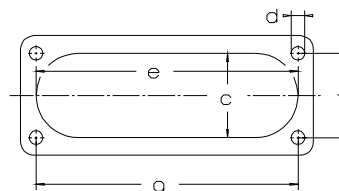

## Bearings

The motors are normally fitted with single-row deep groove ball bearings as listed in the table below.

When there are high axial forces, angular-contact ball bearings should be used. This option is available on request.

When a motor with angular-contact ball bearings is ordered, the method of mounting and direction and magnitude of the axial force must be specified. For special bearings, please see the variant codes.

### Basic version with deep groove ball bearings

Motor size	Number of poles	Deep groove ball bearings	
		D-end	N-end
71M	2-6	6202 VV C3	6202 VV C3
80M	2-6	6204 DDU C3	6204 DDU C3
90S	2-6	6205 DDU C3	6205 DDU C3
90L	2-6	6205 DDU C3	6205 DDU C3
100L	2-8	6206 DDU C3	6206 DDU C3
112M	2-8	6207 DDU C3	6206 DDU C3
132S	2-8	6208 DDU C3	6207 DDU C3
132M	2-8	6208 DDU C3	6207 DDU C3
160M	2-8	6309 DDU C3	6209 DDU C3
160L	2-8	6309 DDU C3	6209 DDU C3

Motor size	Number of poles	Deep groove ball bearings	
		D-end	N-end
180M	2-8	6310 DDU C3	6210 DDU C3
180L	2-8	6310 DDU C3	6210 DDU C3
200L	2-8	6312 DDU C3	6212 DDU C3
225S	4-8	6313 ZZ C3	6213 ZZ C3
225M	2-8	6313 ZZ C3	6213 ZZ C3
250M	2-8	6314/C3	6214/C3
280	2	6316/C4	6316/C4
	4-12	6316/C3	6316/C3
315	2	6316/C4	6316/C4
	4-12	6319/C3	6316/C3
355	2	6319M/C4	6319M/C4
	4-12	6322/C3	6319/C3

## Axially-locked bearings

The D-end bearing is locked, in sizes 71 to 180 with the spring ring and in sizes 200 to 355 with the inner bearing cover. The inner ring is locked by tight tolerance to the shaft.

# Transport locking

Motors that have roller bearings or an angular contact ball bearing are fitted with a transport lock before despatch to prevent damage to the bearings during transport. In case of transport locked bearing, motor sizes 280 to 355 are provided with a warning sign.

Locking may also be fitted in other cases where transport conditions are suspected of being potentially damaging.

# Bearing seals

The motors are as standard provided with seals according to table below.

Motor size	Description D-end	Standard design		Alternative design	Number of poles	d <sub>1</sub>	d <sub>2</sub>	B <sub>1</sub>	b
		Axial seal	N-end	Radial seal (DIN 3760)					
71 to 132	Sealed bearings (2RS) and axial seal, gamma ring, at D-end								
160 to 225	Axial seal, gamma ring, at D-end								
250	Radial seal at D-end								
280	Axial seals at both ends	VS 80	VS 80	80x100x10 <sup>1)</sup>	2	80	100	13.5	10
		VS 80	VS 80	80x100x10	4-12	80	100	13.5	10
315	Axial seals at both ends	VS 80	VS 80	80x100x10 <sup>1)</sup>	2	80	100	13.5	10
		VS 95	VS 80	95x120x12	4-12	95	120	13.5	12
355	Axial seals at both ends	VS 95	VS 95	95x120x12 <sup>1)</sup>	2	95	120	13.5	12
		VS 110	VS 95	110x140x12 <sup>1)</sup>	4-12	110	140	15.5	12

<sup>1)</sup> Viton-seal

Motor sizes 71-132

Motor sizes 160-225

Motor size 250

Motor sizes 280-355

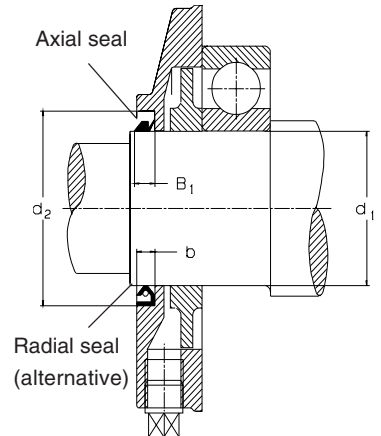
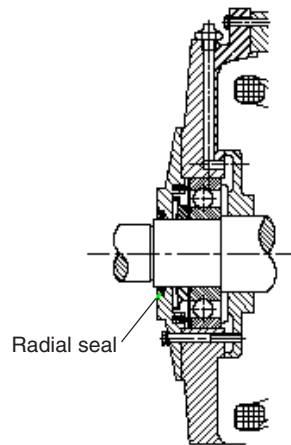
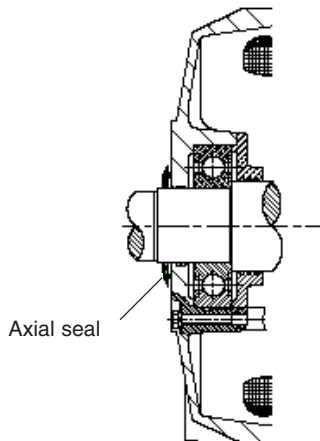
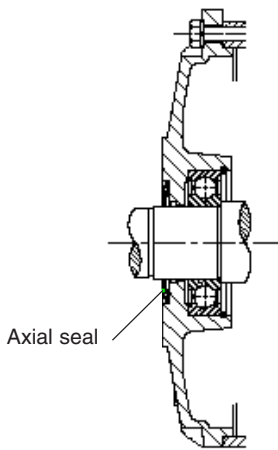

# Bearing life

The nominal life  $L_{10}$  of a bearing is defined according to ISO as the number of operating hours achieved or exceeded by 90% of identical bearings in a large test series under certain specified conditions. 50% of the bearings achieve at least five times this figure.

The calculated bearing life  $L_{10}$  for power transmission by means of a coupling (horizontal machine):

Motor sizes 280 to 355  $\geq 200,000$  hours.

# Lubrication

On delivery, the motors are lubricated with a type of grease intended for use in dry or humid environments, at normal ambient temperature.

Standard versions of motors 71 to 225 are lubricated for life, with lithium based grease.

Motors 160 to 225 are available with either permanent greased or, as against variant codes, with regreasable bearings.

Motors 250 to 355 have grease value lubrication for lubrication in service. The lubrication intervals and quantity are stated in the maintenance manual which comes with the motor.

# Pulley diameter

When the desired bearing life has been determined, the minimum permissible pulley diameter can be calculated with FR (or FRX), according to the formula:

$$D = \frac{1.9 \cdot 10^7 \cdot K \cdot P}{N \cdot F_R}$$

Where:

D = diameter of pulley, mm

P = power requirement, kW

N = motor speed, r/min

K = belt tension factor, dependent on belt type and type of duty. A common value for V belts is K=2.5

F<sub>R</sub> = permissible radial force

# Permissible loadings on shaft

The tables below give the permissible radial force in Newtons, assuming zero axial force. The values are based on normal conditions at 50 Hz and calculated bearing lives of 20,000 and 40,000 hours.

Motors are foot-mounted IM B3 version with force directed sideways. In some cases the strength of the shaft affects the permissible forces.

At 60 Hz the values must be reduced by 10 %.

If the radial force is applied between points X<sub>0</sub> and X<sub>max</sub>, the permissible force F<sub>R</sub> can be calculated from the following formula:

$$F_R = F_{X_0} - \frac{X}{E} (F_{X_0} - F_{X_{max}})$$

E = length of shaft extension in basic version

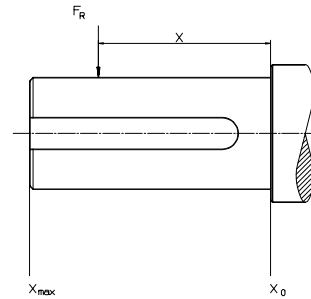

# Permissible radial forces

Motor size	Poles	Length of shaft extension E (mm)	Radial forces Ball bearings			
			20,000 hours		40,000 hours	
			X <sub>0</sub> (N)	X <sub>max</sub> (N)	X <sub>0</sub> (N)	X <sub>max</sub> (N)
71 M	2	30	381	322	303	256
	4	30	480	405	381	322
	6	30	555	469	441	372
80 M	2	40	624	509	495	404
	4	40	788	643	626	511
	6	40	907	740	720	587
	8	40	997	813	791	646
90 S	2	40	686	542	545	430
	4	40	870	687	690	545
	6	40	1000	790	794	627
	8	40	1095	866	870	687

## Permissible radial forces

Motors size	Poles	Length of shaft extension E (mm)	Radial forces Ball bearings 20,000 hours		40,000 hours	
			$X_0$ (N)	$X_{max}$ (N)	$X_0$ (N)	$X_{max}$ (N)
<b>90 L</b>	2	50	696	564	553	448
	4	50	885	717	702	569
	6	50	1015	823	806	653
	8	50	1112	901	883	715
<b>100 L</b>	2	60	979	785	777	622
	4	60	1234	989	979	785
	6	60	1419	1137	1126	903
	8	60	1566	1255	1243	996
<b>112 M</b>	2	60	1258	1014	998	805
	4	60	1592	1284	1264	1019
	6	60	1831	1477	1453	1172
	8	60	2020	1629	1603	1293
<b>132 S</b>	2	80	1435	1122	1139	890
	4	80	1821	1423	1445	1130
	6	80	2079	1625	1650	1290
	8	80	2299	1797	1825	1427
<b>132 M</b>	4	80	1840	1476	1461	1172
	6	80	2107	1690	1672	1341
	8	80	2329	1869	1849	1483
	<b>160 M</b>	2	110	1544	1200	1226
4		110	1948	1513	1546	1201
6		110	2232	1734	1772	1377
8		110	2465	1916	1957	1520
<b>160L</b>	2	110	1563	1243	1240	987
	4	110	1971	1568	1565	1244
	6	110	2259	1797	1793	1426
	8	110	2495	1984	1980	1575
<b>180M</b>	2	110	2984	2371	2368	1882
	4	110	3759	2988	2984	2371
<b>180L</b>	4	110	3802	3073	3017	2439
	6	110	4352	3518	3454	2792
	8	110	4800	3881	3810	3080
<b>200L</b>	2	110	4090	3377	3246	2680
	4	110	5162	4262	4097	3383
	6	110	5909	4879	4690	3872
	8	110	6518	5382	5173	4272
<b>225S</b>	4	140	5763	4526	4574	4593
	8	140	7261	5703	5763	4526
<b>225M</b>	2	110	4591	3811	3644	3025
	4	110	5791	4594	4596	3646
	6	110	6644	5271	5273	4184
	8	110	7296	5788	5791	4594
<b>250M</b>	2	140	5112	4170	4057	3310
	4	140	6440	5254	5111	4170
	6	140	7388	6027	5864	4784
	8	140	8113	6619	6439	5253
<b>280SM_</b>	2	140	7300	6200	5800	4900
	4	140	9200	7800	7300	6200
	6	140	10600	8900	8400	7100
	8	140	11600	9800	9200	7800
<b>315SM_</b>	2	140	7300	6000	5800	4950
	4	170	11300	9400	9000	7500
	6	170	13000	10600	10300	8500
	8	170	14300	10400	11300	9400
<b>315ML</b>	2	140	7300	6000	5800	4950
	4	140	11300	9400	9000	7500
	6	140	13000	10600	10300	8500
	8	140	14300	10400	11300	9400
<b>355 S_</b>	2	140	9000	7900	6200	5300
	4	210	15200	12500	12000	9850
	6	210	17300	14200	13700	11300
	8	210	19000	15600	15200	12400

## Permissible axial forces

The following tables give the permissible axial forces in Newton, assuming zero radial force. The values are based on normal conditions at 50 Hz with standard

bearings and calculated bearing lives of 20,000 and 40,000 hours.

Motors are foot-mounted IM B3 version.

At 60 Hz the values are to be reduced by 10%.

Mounting arrangement IM B3



Motor size	20,000 hours								40,000 hours							
	2-pole		4-pole		6-pole		8-pole		2-pole		4-pole		6-pole		8-pole	
	F <sub>AD</sub> N	F <sub>AZ</sub> N	F <sub>AD</sub> N	F <sub>AZ</sub> N	F <sub>AD</sub> N	F <sub>AZ</sub> N	F <sub>AD</sub> N	F <sub>AZ</sub> N	F <sub>AD</sub> N	F <sub>AZ</sub> N	F <sub>AD</sub> N	F <sub>AZ</sub> N	F <sub>AD</sub> N	F <sub>AZ</sub> N	F <sub>AD</sub> N	F <sub>AZ</sub> N
71	270	270	360	360	440	440	-	-	200	200	270	270	320	320	-	-
80	430	430	590	590	710	710	800	800	320	320	440	440	530	530	600	600
90	470	470	650	650	780	780	870	870	350	350	470	470	580	580	650	650
100	650	650	880	880	1060	1060	1200	1200	480	480	650	650	780	780	890	890
112	840	840	1160	1160	1380	1380	1570	1570	620	620	850	850	1020	1020	1170	1170
132 S <sub>-</sub>	950	950	1300	1300	1540	1540	1760	1760	690	690	960	960	1140	1140	1310	1310
132 M <sub>-</sub>	-	-	1300	1300	1540	1540	1760	1760	-	-	950	950	1140	1140	1310	1310
160	1020	1020	1380	1380	1650	1650	1880	1880	740	740	1020	1020	1210	1210	1390	1390
180M	1970	1970	2660	2660	-	-	-	-	1440	1440	1970	1970	-	-	-	-
180L	-	-	2660	2660	3200	3200	3620	3620	-	-	1970	1970	2350	2350	2670	2670
200	2570	2570	3490	3490	4200	4200	4750	4750	1890	1890	2580	2580	3080	3080	3500	3500
225S	-	-	3900	3900	-	-	5310	5310	-	-	2880	2880	-	-	3900	3900
225M	2870	2870	3900	3900	4720	4720	5310	5310	2120	2120	2880	2880	3460	3460	3900	3900
250	3220	3220	4380	4380	5290	5290	5960	5960	2380	2380	3220	3220	3880	3880	4380	4380
280	7300	5300	8000	6000	9000	7000	10000	8000	5750	3750	6200	4200	6900	4900	7700	5700
315	7000	5000	9000	7000	10600	8600	11600	9600	5600	3600	6900	4900	7900	5900	8900	6900
355	10500	3500	13500	6500	15300	8300	16800	9800	8750	1750	10800	3800	12000	5000	13300	6300

Mounting arrangement IM V1

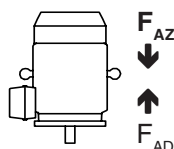

Motor size	20,000 hours								40,000 hours							
	2-pole		4-pole		6-pole		8-pole		2-pole		4-pole		6-pole		8-pole	
	F <sub>AD</sub> N	F <sub>AZ</sub> N	F <sub>AD</sub> N	F <sub>AZ</sub> N	F <sub>AD</sub> N	F <sub>AZ</sub> N	F <sub>AD</sub> N	F <sub>AZ</sub> N	F <sub>AD</sub> N	F <sub>AZ</sub> N	F <sub>AD</sub> N	F <sub>AZ</sub> N	F <sub>AD</sub> N	F <sub>AZ</sub> N	F <sub>AD</sub> N	F <sub>AZ</sub> N
71	280	260	380	350	450	420	-	-	210	190	280	250	340	310	-	-
80	450	410	620	560	740	560	830	770	340	300	460	410	550	500	620	560
90	500	440	590	600	820	730	920	830	380	320	510	440	620	530	690	600
100	710	590	950	800	1140	980	1280	1110	530	420	720	560	860	700	970	800
112	920	770	1260	1050	1490	1270	1680	1470	690	540	950	740	1130	910	1270	1060
132 S <sub>-</sub>	1050	830	1450	1160	1690	1400	1930	1600	800	570	1100	810	1280	990	1470	1140
132 M <sub>-</sub>	-	-	1480	1120	1730	1320	1950	1580	-	-	1130	770	1320	910	1490	1120
160 M <sub>-</sub>	1240	750	1670	1100	1960	1340	2140	1560	970	480	1300	730	1530	900	1650	1070
160 L <sub>-</sub>	1320	710	1730	1030	2050	1250	2260	1500	1050	440	1370	670	1610	820	1770	1010
180 M <sub>-</sub>	2320	1630	3100	2230	-	-	-	-	1780	1100	2400	1540	-	-	-	-
180 L <sub>-</sub>	-	-	3170	2150	3750	2650	4160	3100	-	-	2480	1460	2900	1800	3200	2140
200	3050	2050	4100	2880	4830	3510	5450	4060	2370	1370	3180	1970	3700	2390	4200	2800
225 S <sub>-</sub>	-	-	4680	3130	-	-	6120	4500	-	-	3650	2100	-	-	4720	3090
225 M <sub>-</sub>	3570	2180	4770	3040	5650	3790	6250	4370	2810	1420	3740	2020	4390	2530	4850	2960
250	4090	2360	5570	3180	6520	4070	7210	4700	3240	1520	4420	2030	5100	2650	5630	3120
280	8500	4300	9500	4600	11000	5500	12200	6600	6950	2700	7700	2800	8900	3350	9750	4200
315 SM <sub>-</sub>	9000	3700	11600	5400	13500	6200	14500	7500	7450	2100	9450	3200	10900	3650	11900	4650
315 ML <sub>-</sub>	9600	3400	12400	5000	14800	5600	16200	7000	8100	1850	10100	2850	12200	3150	13200	4150
355 S <sub>-</sub>	14100	1600	18500	3800	21200	5000	23000	6800	12200	<sup>1)</sup>	15700	1000	18000	1750	19400	3100

# Ordering information

## Sample order

When placing an order, please state the following minimum data in the order, as in the example.

The product code of the motor is composed in accordance with the following example.

Motor type	M2QA 90S4A
Pole number	4
Mounting arrangement (IM-code)	IM B3 (IM 1001)
Rated output	1.1 kW
Product code	3GQA092101-ADA
Variant codes if needed	

A	B	C	D, E, F	G	
M2QA	90S4A	3GQA 092 101 -	AD A	003 etc.	
		1-4   5-6   7   8-10   11   12   13   14			<b>A</b> Motor type <b>B</b> Motor size <b>C</b> Product code <b>D</b> Mounting arrangement code <b>E</b> Voltage and frequency code <b>F</b> Generation code <b>G</b> Variant codes

### Explanation of the product code (C, D, E, F):

#### Positions 1 to 4

**M2QA** = Totally enclosed fan cooled squirrel cage motor with cast iron frame

#### Positions 5 and 6

IEC frame

07 = 71	11 = 112	20 = 200	31 = 315
08 = 80	13 = 132	22 = 225	35 = 355
09 = 90	16 = 160	25 = 250	
10 = 100	18 = 180	28 = 280	

#### Position 7

Speed (Pole pairs)

1 = 2 poles	6 = 12 poles
2 = 4 poles	7 = >12 poles
3 = 6 poles	8 = Two-speed motors
4 = 8 poles	9 = Multi-speed motors
5 = 10 poles	

#### Positions 8 to 10

Serial number

#### Position 11

-(dash)

#### Position 12

Mounting arrangement

**A** = Foot-mounted, top-mounted terminal box  
**R** = Foot-mounted, terminal box on RHS, seen from D-end

**L** = Foot-mounted, terminal box on LHS, seen from D-end

**B** = Flange-mounted, large flange

**C** = Flange-mounted, small flange sizes (71-112)

**H** = Foot- and flange-mounted

#### Position 13

Voltage and frequency code

See tables on appropriate page

#### Position 14

Generation code

A, B, C...

**The product code must be, if needed, followed by variant codes.**

### Code letters for supplementing the product code for voltage and frequency:

A	B	D	E	F	H
380 VY 50 Hz	380 VΔ 50 Hz	380-420 VΔ 50 Hz 660-690 VY 50 Hz 440-480 <sup>1)</sup> VΔ 60 Hz	500 VΔ 50 Hz 575 VΔ 60 Hz	500 VY 50 Hz 575 VY 60 Hz	415 VΔ 50 Hz
S	T	U	X		
220-240 VΔ 50 Hz 380-420 VY 50 Hz 440-480 VY 60 Hz	660 VΔ 50 Hz	690 VΔ 50 Hz	Other rated voltage, connection or frequency, max. 690 V		<sup>1)</sup> 480 V not stamped on sizes 160 to 250

# General purpose cast iron motors

## Technical data for totally enclosed squirrel cage three phase motors



IP 55 – IC 411 – Insulation class F, temperature rise class B

Output kW	Motor type	Product code	Speed r/min	Efficiency		Power factor cos φ 100%	Current		Torque			
				Full load 100%	3/4 load 75%		$I_N$ A	$I_s$ $I_N$	$T_N$ Nm	$T_s$ $T_N$	$T_{max}$ $T_N$	
<b>3000 r/min = 2 poles</b>				<b>400 V 50 Hz</b>								
0.37	M2QA 71 M2A	3GQA 071 301-••A	2780	70.0	68.0	0.81	0.94	6.1	1.27	2.2	3.0	
0.55	M2QA 71 M2B	3GQA 071 302-••A	2785	73.0	72.4	0.82	1.33	6.1	1.89	2.2	2.7	
0.75	M2QA 80 M2A	3GQA 081 301-••A	2840	75.0	75.5	0.85	1.7	6.1	2.52	2.2	3.0	
1.1	M2QA 80 M2B	3GQA 081 302-••A	2855	78.0	77.9	0.85	2.4	7.0	3.68	2.2	2.2	
1.5	M2QA 90 S2A	3GQA 091 101-••A	2850	79.0	79.0	0.87	3.15	7.0	5.03	2.2	2.5	
2.2	M2QA 90 L2A	3GQA 091 501-••A	2850	81.5	81.8	0.86	4.53	7.0	7.37	2.2	3.5	
3	M2QA 100 L2A	3GQA 101 501-••A	2860	83.0	83.2	0.88	5.93	7.0	10.02	2.2	3.0	
4	M2QA 112 M2A	3GQA 111 301-••A	2900	85.0	84.6	0.90	7.55	7.0	13.17	2.2	3.2	
5.5	M2QA 132 S2A	3GQA 131 101-••A	2920	87.5	87.9	0.89	10.2	7.0	17.99	2.2	3.0	
7.5	M2QA 132 S2B	3GQA 131 102-••A	2920	88.5	90.1	0.90	13.6	7.0	24.53	2.2	3.5	
11	M2QA 160 M2A	3GQA 161 301-••A	2930	90.0	90.5	0.89	19.82	6.5	35.85	2.5	3.1	
15	M2QA 160 M2B	3GQA 161 302-••A	2920	90.0	90.1	0.89	27.03	6.5	49.06	2.5	2.6	
18.5	M2QA 160 L2A	3GQA 161 501-••A	2930	90.5	90.9	0.90	32.78	6.5	60	2.5	2.7	
22	M2QA 180 M2A	3GQA 181 301-••A	2940	90.8	91.0	0.90	38.86	6.5	71	2.3	2.5	
30	M2QA 200 L2A	3GQA 201 501-••A	2955	91.4	91.1	0.90	52	6.5	96	2.2	2.6	
37	M2QA 200 L2B	3GQA 201 502-••A	2955	92.2	91.8	0.90	64	6.5	119	2.3	2.6	
45	M2QA 225 M2A	3GQA 221 301-••A	2970	92.6	92.2	0.89	78	7.0	144	2.5	2.7	
55	M2QA 250 M2A	3GQA 251 301-••A	2960	93.4	91.7	0.89	96	7.5	177	2.4	2.7	
75	M2BAT 280 SMA	3GBA 281 210-••D	2974	94.1	93.6	0.87	134	6.7	241	1.7	2.6	
90	M2BAT 280 SMB	3GBA 281 220-••D	2970	94.5	94.2	0.89	156	6.4	289	1.7	2.5	
110 <sup>1)</sup>	M2BAT 280 SMC	3GBA 281 230-••D	2973	95.0	94.8	0.90	187	6.7	353	1.9	2.6	
110	M2BAT 315 SMA	3GBA 311 210-••D	2979	94.1	93.4	0.85	198	6.3	353	1.5	2.5	
132	M2BAT 315 SMB	3GBA 311 220-••D	2977	94.7	94.1	0.87	232	6.3	423	1.7	2.5	
160	M2BAT 315 SMC	3GBA 311 230-••D	2976	95.1	94.8	0.88	273	6.2	513	1.7	2.4	
200	M2BAT 315 MLA	3GBA 311 410-••D	2980	95.7	95.3	0.88	345	7.9	641	2.6	3.1	
250	M2BAT 355 S	3GBA 351 100-••D	2983	95.7	95.3	0.89	424	6.8	800	1.5	2.8	

<sup>1)</sup> High-output design

<sup>2)</sup> Temperature rise class F by voltage 380 V 50 Hz.

The two bullets in the product code indicate choice of mounting arrangement, voltage and frequency (see ordering information page).



# General purpose cast iron motors

## Technical data for totally enclosed squirrel cage three phase motors

IP 55 – IC 411 – Insulation class F, temperature rise class B

Output kW	Motor type	Speed r/min	Efficiency %	Power factor cos φ	Current I <sub>N</sub> A	Speed r/min	Efficiency %	Power factor cos φ	Current I <sub>N</sub> A	Moment of inertia J = ¼ D <sup>2</sup> kgm <sup>2</sup>	Weight kg	Sound pressure level L <sub>p</sub> dB(A)
<b>3000 r/min = 2 poles</b>			<b>380 V 50 Hz</b>				<b>415 V 50 Hz</b>					
0.37	M2QA 71 M2A	2765	70.0	0.83	0.97	2795	70.0	0.79	0.93	0.0003	10	56
0.55	M2QA 71 M2B	2780	73.0	0.84	1.37	2800	73.0	0.79	1.33	0.00037	11	56
0.75	M2QA 80 M2A	2825	75.5	0.86	1.75	2855	75.0	0.85	1.64	0.00091	16	57
1.1	M2QA 80 M2B	2840	77.5	0.86	2.52	2870	78.0	0.83	2.37	0.00107	17	58
1.5	M2QA 90 S2A	2835	79.0	0.90	3.23	2865	79.0	0.86	3.08	0.00135	21	61
2.2	M2QA 90 L2A	2835	81.5	0.89	4.61	2865	81.0	0.83	4.56	0.00163	24	61
3	M2QA 100 L2A	2845	83.0	0.90	6.14	2875	83.5	0.86	5.85	0.00402	33	65
4	M2QA 112 M2A	2885	85.0	0.92	7.82	2915	85.0	0.87	7.53	0.00671	42	67
5.5	M2QA 132 S2A	2905	87.5	0.90	10.7	2935	88.0	0.88	9.94	0.01241	58	70
7.5	M2QA 132 S2B	2905	87.5	0.90	14.5	2935	89.0	0.90	13.1	0.01491	63	70
11	M2QA 160 M2A	2918	90.0	0.91	20.41	2930	90.0	0.87	19.54	0.0436	112	72
15	M2QA 160 M2B	2917	90.0	0.91	27.82	2932	90.0	0.88	26.35	0.0551	122	72
18.5	M2QA 160 L2A	2920	90.5	0.91	34.13	2935	90.5	0.89	31.95	0.06549	142	72
22	M2QA 180 M2A	2940	90.8	0.91	40.45	2955	90.8	0.88	38.3	0.08805	170	72
30	M2QA 200 L2A	2950	91.2	0.91	54	2960	91.3	0.89	51	0.14821	235	81
37	M2QA 200 L2B	2950	91.7	0.91	67	2960	92.3	0.89	62	0.16822	254	81
45	M2QA 225 M2A	2965	92.2	0.90	82	2975	92.6	0.87	77	0.29345	328	81
55	M2QA 250 M2A	2956	93.2	0.90	100	2962	93.5	0.88	93	0.3784	390	84
75	M2BAT 280 SMA	2970	94.0	0.88	137	2976	94.2	0.86	130	0.7	570	78
90 <sup>2)</sup>	M2BAT 280 SMB	2966	94.2	0.89	163	2974	94.6	0.88	151	0.82	610	78
110 <sup>2)</sup>	M2BAT 280 SMC	2968	94.8	0.90	198	2975	95.1	0.89	180	1.05	660	78
110	M2BAT 315 SMA	2976	94.1	0.86	208	2980	94.1	0.83	197	1.05	820	83
132 <sup>2)</sup>	M2BAT 315 SMB	2974	94.5	0.87	243	2979	94.7	0.85	230	1.25	870	83
160 <sup>2)</sup>	M2BAT 315 SMC	2972	95.0	0.88	290	2978	95.2	0.88	265	1.5	960	83
200 <sup>2)</sup>	M2BAT 315 MLA	2978	95.6	0.89	358	2982	95.7	0.87	335	1.95	1130	83
250	M2BAT 355 S	2981	95.7	0.90	440	2984	95.7	0.88	412	2.7	1500	83

<sup>1)</sup> High-output design

<sup>2)</sup> Temperature rise class F by voltage 380 V 50 Hz.

# General purpose cast iron motors

## Technical data for totally enclosed squirrel cage three phase motors



IP 55 – IC 411 – Insulation class F, temperature rise class B

Output kW	Motor type	Product code	Speed r/min	Efficiency		Power factor cos φ	Current		Torque			
				Full load 100%	3/4 load 75%		$I_N$	$I_s$	$T_N$	$T_s$	$T_{max}$	
							A	$I_N$	Nm	$T_N$	$T_N$	$T_N$
<b>1500 r/min = 4 poles</b>			<b>400 V 50 Hz</b>				<b>Basic design</b>					
0.25	M2QA 71 M4A	3GQA 072 301-••A	1395	65.5	63.3	0.72	0.77	5.2	1.71	2.1	2.7	
0.37	M2QA 71 M4B	3GQA 072 302-••A	1395	68.5	69.4	0.75	1.04	5.2	2.53	2.1	2.7	
0.55	M2QA 80 M4A	3GQA 082 301-••A	1410	73.5	71.4	0.72	1.5	5.2	3.73	2.4	2.7	
0.75	M2QA 80 M4B	3GQA 082 302-••A	1415	74.5	75.2	0.75	1.93	6.0	5.06	2.4	2.6	
1.1	M2QA 90 S4A	3GQA 092 101-••A	1400	77.5	77.8	0.78	2.65	6.0	7.5	2.3	2.4	
1.5	M2QA 90 L4A	3GQA 092 501-••A	1390	78.5	79.2	0.79	3.5	6.0	10.31	2.3	2.6	
2.2	M2QA 100 L4A	3GQA 102 501-••A	1430	81.5	82.3	0.81	4.85	6.0	14.69	2.3	2.7	
3	M2QA 100 L4B	3GQA 102 502-••A	1420	82.8	82.5	0.83	6.3	6.5	20.18	2.3	2.8	
4	M2QA 112 M4A	3GQA 112 301-••A	1430	85.0	84.6	0.82	8.29	6.5	26.71	2.3	2.8	
5.5	M2QA 132 S4A	3GQA 132 101-••A	1430	86.0	87.1	0.85	10.9	6.5	36.73	2.3	2.9	
7.5	M2QA 132 M4A	3GQA 132 301-••A	1440	88.5	88.3	0.85	14.4	6.5	49.74	2.3	2.7	
11	M2QA 160 M4A	3GQA 162 301-••A	1460	89.5	90.0	0.85	20.87	6.5	71	2.4	2.8	
15	M2QA 160 L4A	3GQA 162 501-••A	1460	90.0	90.4	0.86	27.97	6.5	98	2.3	2.6	
18.5	M2QA 180 M4A	3GQA 182 301-••A	1470	91.0	90.9	0.86	34.12	6.5	120	2.3	3.4	
22	M2QA 180 L4A	3GQA 182 501-••A	1470	91.5	90.0	0.88	39.44	6.5	142	2.4	3.0	
30	M2QA 200 L4A	3GQA 202 501-••A	1470	92.2	91.8	0.88	53	6.5	194	2.2	2.9	
37	M2QA 225 S4A	3GQA 222 101-••A	1480	92.6	91.2	0.85	67	7.0	238	2.2	2.7	
45	M2QA 225 M4A	3GQA 222 301-••A	1480	92.8	91.7	0.87	80	7.0	290	2.2	2.7	
55	M2QA 250 M4A	3GQA 252 301-••A	1480	93.4	91.3	0.87	98	7.0	354	2.4	2.7	
75	M2BAT 280 SMA	3GBA 282 210-••D	1483	94.2	94.2	0.83	138	6.3	483	2.1	2.6	
90	M2BAT 280 SMB	3GBA 282 220-••D	1481	94.6	94.7	0.86	162	6.4	580	2.1	2.4	
110	<sup>1)</sup> M2BAT 280 SMC	3GBA 282 230-••D	1484	95.1	95.1	0.85	196	7.1	708	2.7	2.8	
110	M2BAT 315 SMA	3GBA 312 210-••D	1486	94.6	94.2	0.84	203	6.4	707	1.7	2.3	
132	M2BAT 315 SMB	3GBA 312 220-••D	1485	94.9	94.7	0.85	239	6.1	849	1.9	2.4	
160	M2BAT 315 SMC	3GBA 312 230-••D	1486	95.4	95.2	0.85	286	6.7	1028	2.1	2.6	
200	M2BAT 315 MLA	3GBA 312 410-••D	1485	95.7	95.6	0.86	354	6.4	1286	2.1	2.5	
250	M2BAT 355 S	3GBA 352 100-••D	1488	95.6	95.3	0.85	448	6.7	1604	2.0	2.6	

<sup>1)</sup> High-output design

<sup>2)</sup> Temperature rise class F by voltage 380 V 50 Hz.

The two bullets in the product code indicate choice of mounting arrangement, voltage and frequency (see ordering information page).

# General purpose cast iron motors

## Technical data for totally enclosed squirrel cage three phase motors

IP 55 – IC 411 – Insulation class F, temperature rise class B

Output kW	Motor type	Speed r/min	Efficiency %	Power factor cos φ	Current I <sub>N</sub> A	Speed r/min	Efficiency %	Power factor cos φ	Current I <sub>N</sub> A	Moment of inertia J = ¼ D <sup>2</sup> kgm <sup>2</sup>	Weight kg	Sound pressure level L <sub>p</sub> dB(A)
1500 r/min = 4 poles			380 V 50 Hz			415 V 50 Hz			Basic design			
0.25	M2QA 71 M4A	1385	66.0	0.74	0.78	1405	64.0	0.69	0.79	0.00053	11	43
0.37	M2QA 71 M4B	1385	69.0	0.78	1.05	1405	68.0	0.71	1.07	0.00066	11	45
0.55	M2QA 80 M4A	1400	73.5	0.75	1.52	1420	72.5	0.68	1.55	0.00145	16	46
0.75	M2QA 80 M4B	1405	74.5	0.78	1.97	1425	74.0	0.72	1.96	0.00174	17	46
1.1	M2QA 90 S4A	1390	77.0	0.80	2.72	1410	77.5	0.75	2.65	0.00254	21	52
1.5	M2QA 90 L4A	1380	78.5	0.80	3.64	1400	78.5	0.77	3.48	0.00317	25	52
2.2	M2QA 100 L4A	1420	81.5	0.82	4.98	1440	81.4	0.78	4.85	0.00679	32	53
3	M2QA 100 L4B	1410	82.5	0.85	6.5	1430	82.7	0.82	6.17	0.00862	36	53
4	M2QA 112 M4A	1420	84.5	0.84	8.57	1440	85.0	0.80	8.24	0.01306	45	56
5.5	M2QA 132 S4A	1420	85.5	0.87	11.3	1440	86.5	0.83	10.7	0.02673	60	59
7.5	M2QA 132 M4A	1430	88.0	0.85	15.2	1450	88.0	0.84	14.1	0.03432	73	59
11	M2QA 160 M4A	1455	89.5	0.87	21.5	1463	89.5	0.83	20.6	0.06543	116	66
15	M2QA 160 L4A	1452	90.0	0.88	28.8	1461	90.0	0.85	27.28	0.09349	137	66
18.5	M2QA 180 M4A	1465	91.0	0.88	35.1	1470	91.0	0.82	34.49	0.16049	170	66
22	M2QA 180 L4A	1465	91.5	0.90	40.6	1475	91.5	0.86	38.9	0.18046	186	66
30	M2QA 200 L4A	1465	92.3	0.89	55	1470	86.8	0.87	55	0.2819	254	71
37	M2QA 225 S4A	1475	92.3	0.85	71	1480	92.0	0.82	68	0.37	308	73
45	M2QA 225 M4A	1475	92.6	0.88	83	1480	92.8	0.85	79	0.42	335	73
55	M2QA 250 M4A	1477	93.2	0.88	102	1482	93.6	0.86	95	0.78	450	76
75	<sup>2)</sup> M2BAT 280 SMA	1480	94.0	0.85	143	1484	94.2	0.82	137	1.05	560	71
90	<sup>2)</sup> M2BAT 280 SMB	1478	94.2	0.86	169	1483	94.7	0.85	157	1.32	600	71
110	<sup>2)</sup> M2BAT 280 SMC	1481	94.8	0.86	204	1485	95.2	0.84	191	1.7	660	71
110	<sup>2)</sup> M2BAT 315 SMA	1484	94.5	0.85	209	1487	94.6	0.82	198	1.9	800	78
132	<sup>2)</sup> M2BAT 315 SMB	1483	94.8	0.86	248	1486	95.0	0.84	232	2.2	855	78
160	<sup>2)</sup> M2BAT 315 SMC	1483	95.0	0.86	300	1487	95.4	0.84	279	2.6	930	78
200	<sup>2)</sup> M2BAT 315 MLA	1482	95.2	0.86	375	1486	95.7	0.85	343	3.2	1030	78
250	M2BAT 355 S	1487	95.6	0.86	465	1489	95.6	0.84	438	5.4	1500	82

<sup>1)</sup> High-output design

<sup>2)</sup> Temperature rise class F by voltage 380 V 50 Hz.

# General purpose cast iron motors

## Technical data for totally enclosed squirrel cage three phase motors

IP 55 – IC 411 – Insulation class F, temperature rise class B

Output kW	Motor type	Product code	Speed r/min	Efficiency		Power factor cos φ 100%	Current		Torque			
				Full load 100%	3/4 load 75%		$I_N$	$I_s$	$T_N$	$T_s$	$T_{max}$	
							A	$I_N$	Nm	$T_N$	$T_N$	$T_N$
<b>1000 r/min = 6 poles</b>			<b>400 V 50 Hz</b>				<b>Basic design</b>					
0.18	M2QA 71 M6A	3GQA 073 301-••A	910	55.0	50.1	0.65	0.73	4.0	1.89	1.8	2.4	
0.25	M2QA 71 M6B	3GQA 073 302-••A	890	60.0	58.3	0.65	0.93	4.0	2.68	1.8	2.5	
0.37	M2QA 80 M6A	3GQA 083 301-••A	930	63.0	63.2	0.66	1.29	5.0	3.8	1.9	2.0	
0.55	M2QA 80 M6B	3GQA 083 302-••A	925	65.0	65.1	0.68	1.8	5.0	5.68	1.9	1.8	
0.75	M2QA 90 S6A	3GQA 093 101-••A	920	71.0	70.2	0.72	2.12	5.0	7.79	2.0	2.3	
1.1	M2QA 90 L6A	3GQA 093 501-••A	920	73.0	73.1	0.74	2.94	5.0	11.42	2.0	2.6	
1.5	M2QA 100 L6A	3GQA 103 501-••A	940	76.0	75.3	0.77	3.78	5.5	15.24	2.0	2.4	
2.2	M2QA 112 M6A	3GQA 113 301-••A	940	80.0	81.2	0.76	5.23	5.5	22.35	2.0	2.3	
3	M2QA 132 S6A	3GQA 133 101-••A	960	82.5	83.5	0.78	6.73	6.5	29.84	2.0	2.4	
4	M2QA 132 M6A	3GQA 133 301-••A	960	84.0	84.2	0.77	8.93	6.5	39.79	2.0	2.9	
5.5	M2QA 132 M6B	3GQA 133 302-••A	960	86.0	85.6	0.79	11.7	6.5	54	2.0	3.0	
7.5	M2QA 160 M6A	3GQA 163 301-••A	970	88.0	88.3	0.78	15.77	6.0	73	2.0	2.3	
11	M2QA 160 L6A	3GQA 163 501-••A	970	88.5	88.6	0.78	23	6.0	108	2.2	2.4	
15	M2QA 180 L6A	3GQA 183 501-••A	980	89.0	89.1	0.82	29.67	6.0	146	2.3	2.9	
18.5	M2QA 200 L6A	3GQA 203 501-••A	980	90.3	90.2	0.82	36.06	6.0	180	2.2	2.5	
22	M2QA 200 L6B	3GQA 203 502-••A	980	90.4	90.3	0.83	42.32	6.0	214	2.1	3.2	
30	M2QA 225 M6A	3GQA 223 301-••A	980	90.8	89.2	0.78	61	6.6	292	2.2	2.9	
37	M2QA 250 M6A	3GQA 253 301-••A	980	92.2	92.4	0.88	66	6.8	360	2.3	2.6	
45	M2BAT 280 SMA	3GBA 283 210-••D	990	93.5	93.3	0.82	85	6.7	434	2.4	2.4	
55	M2BAT 280 SMB	3GBA 283 220-••D	989	93.8	93.7	0.83	103	6.4	531	2.4	2.4	
75	<sup>1)</sup> M2BAT 280 SMC	3GBA 283 230-••D	989	94.5	94.5	0.83	139	6.9	724	2.6	2.5	
75	M2BAT 315 SMA	3GBA 313 210-••D	992	94.2	94.0	0.80	145	6.3	722	1.9	2.3	
90	M2BAT 315 SMB	3GBA 313 220-••D	991	94.8	94.7	0.83	166	6.5	867	1.9	2.3	
110	M2BAT 315 SMC	3GBA 313 230-••D	991	95.1	95.0	0.82	206	6.7	1060	2.1	2.6	
132	M2BAT 315 MLA	3GBA 313 410-••D	991	95.3	95.2	0.83	242	6.5	1272	2.2	2.5	
160	M2BAT 355 S	3GBA 353 100-••D	992	95.3	95.2	0.83	293	6.2	1540	1.8	2.3	

<sup>1)</sup> High-output design

<sup>2)</sup> Temperature rise class F by voltage 380 V 50 Hz.

The two bullets in the product code indicate choice of mounting arrangement, voltage and frequency (see ordering information page).

# General purpose cast iron motors

## Technical data for totally enclosed squirrel cage three phase motors

IP 55 – IC 411 – Insulation class F, temperature rise class B

Output kW	Motor type	Speed r/min	Efficiency %	Power factor cos φ	Current I <sub>N</sub> A	Speed r/min	Efficiency %	Power factor cos φ	Current I <sub>N</sub> A	Moment of inertia J = ¼ D <sup>2</sup> kgm <sup>2</sup>	Weight kg	Sound pressure level L <sub>p</sub> dB(A)
<b>1000 r/min = 6 poles</b>			<b>380 V 50 Hz</b>			<b>415 V 50 Hz</b>			<b>Basic design</b>			
0.18	M2QA 71 M6A	905	55.5	0.69	0.72	915	52.5	0.62	0.77	0.00056	10	42
0.25	M2QA 71 M6B	885	60.0	0.65	0.98	895	59.0	0.62	0.95	0.00074	11	42
0.37	M2QA 80 M6A	925	63.5	0.70	1.29	935	62.0	0.62	1.33	0.00159	17	45
0.55	M2QA 80 M6B	920	65.0	0.71	1.82	930	65.5	0.66	1.79	0.00196	18	45
0.75	M2QA 90 S6A	915	71.0	0.75	2.13	925	70.5	0.69	2.15	0.00292	21	48
1.1	M2QA 90 L6A	915	73.0	0.77	2.98	925	73.0	0.70	2.98	0.00379	25	48
1.5	M2QA 100 L6A	935	76.0	0.79	3.8	945	75.5	0.75	3.73	0.00999	32	51
2.2	M2QA 112 M6A	935	79.0	0.77	5.5	945	80.0	0.75	5.14	0.03116	40	54
3	M2QA 132 S6A	955	82.0	0.81	6.87	965	82.5	0.76	6.66	0.03116	55	56
4	M2QA 132 M6A	955	84.0	0.77	9.39	965	84.0	0.75	8.84	0.04074	65	56
5.5	M2QA 132 M6B	945	85.5	0.80	12.3	955	86.0	0.78	11.4	0.05332	75	56
7.5	M2QA 160 M6A	968	88.0	0.79	16.4	975	88.0	0.75	15.81	0.09231	119	61
11	M2QA 160 L6A	966	88.5	0.80	23.6	975	88.5	0.75	23.06	0.1297	140	62
15	M2QA 180 L6A	980	89.0	0.84	30.5	985	89.0	0.79	29.68	0.2418	180	63
18.5	M2QA 200 L6A	975	90.6	0.84	36.9	980	90.1	0.79	36.16	0.34174	231	64
22	M2QA 200 L6B	975	90.9	0.84	43.8	980	90.1	0.81	41.93	0.46837	254	64
30	M2QA 225 M6A	980	90.5	0.78	64	980	90.9	0.76	60	0.62691	308	66
37	M2QA 250 M6A	978	92.0	0.90	68	982	92.3	0.86	64	0.97	382	68
45	M2BAT 280 SMA	988	93.9	0.83	89	990	93.5	0.80	84	1.6	540	71
55	M2BAT 280 SMB	987	93.5	0.84	108	990	93.8	0.82	101	1.9	580	71
75	M2BAT 280 SMC	987	94.3	0.84	144	990	94.6	0.82	135	2.6	660	71
75 <sup>1)</sup>	M2BAT 315 SMA	990	94.1	0.82	148	992	94.2	0.77	143	2.8	780	75
90 <sup>2)</sup>	M2BAT 315 SMB	990	95.7	0.84	174	992	94.8	0.81	163	3.6	870	75
110 <sup>2)</sup>	M2BAT 315 SMC	990	94.9	0.83	215	991	95.0	0.80	203	4.4	930	75
132 <sup>2)</sup>	M2BAT 315 MLA	989	95.1	0.83	255	991	95.3	0.82	237	5.3	1040	75
160	M2BAT 355 S	991	95.2	0.83	307	993	95.3	0.82	287	7.3	1500	77

<sup>1)</sup> High-output design

<sup>2)</sup> Temperature rise class F by voltage 380 V 50 Hz.

# General purpose cast iron motors

## Technical data for totally enclosed squirrel cage three phase motors

IP 55 – IC 411 – Insulation class F, temperature rise class B

Output kW	Motor type	Product code	Speed r/min	Efficiency		Power factor cos φ	Current		Torque		
				Full load 100%	3/4 load 75%		$I_N$	$I_s$	$T_N$	$T_s$	$T_{max}$
			400 V 50 Hz			Basic design					
						A	$I_N$	Nm	$T_N$	$T_N$	$T_N$
<b>0.18</b>	<b>M2QA 80 M8A</b>	3GQA 084 301-••A	700	51.0	50.1	0.60	0.85	3.3	2.46	1.8	1.9
<b>0.25</b>	<b>M2QA 80 M8B</b>	3GQA 084 302-••A	700	54.5	53.3	0.60	1.11	3.6	3.41	1.8	1.9
<b>0.37</b>	<b>M2QA 90 S8A</b>	3GQA 094 101-••A	700	62.5	62.1	0.60	1.42	4.4	5.05	1.8	1.9
<b>0.55</b>	<b>M2QA 90 L8A</b>	3GQA 094 501-••A	700	63.5	63.3	0.60	2.07	4.7	7.5	1.8	2.0
<b>0.75</b>	<b>M2QA 100 L8A</b>	3GQA 104 501-••A	700	70.0	70.1	0.64	2.42	5.0	10.23	1.8	2.2
<b>1.1</b>	<b>M2QA 100 L8B</b>	3GQA 104 502-••A	700	71.5	70.3	0.65	3.45	5.0	15.01	1.8	2.4
<b>1.5</b>	<b>M2QA 112 M8A</b>	3GQA 114 301-••A	700	75.0	75.4	0.68	4.27	5.0	20.46	1.8	2.4
<b>2.2</b>	<b>M2QA 132 S8A</b>	3GQA 134 101-••A	710	81.0	81.8	0.70	5.6	5.5	29.59	1.8	2.5
<b>3</b>	<b>M2QA 132 M8A</b>	3GQA 134 301-••A	710	81.0	81.4	0.75	7.13	5.5	40.35	1.8	2.2
<b>4</b>	<b>M2QA 160 M8A</b>	3GQA 164 301-••A	720	84.0	84.0	0.73	9.42	5.5	53	2.1	2.6
<b>5.5</b>	<b>M2QA 160 M8B</b>	3GQA 164 302-••A	720	85.5	85.6	0.74	12.55	5.5	72	2.1	2.8
<b>7.5</b>	<b>M2QA 160 L8A</b>	3GQA 164 501-••A	720	86.5	85.8	0.74	16.91	5.5	99	2.1	2.5
<b>11</b>	<b>M2QA 180 L8A</b>	3GQA 184 501-••A	730	87.7	87.0	0.77	23.51	5.4	143	2.0	2.8
<b>15</b>	<b>M2QA 200 L8A</b>	3GQA 204 501-••A	730	89.0	89.4	0.76	32.009	5.5	196	2.3	2.8
<b>18.5</b>	<b>M2QA 225 S8A</b>	3GQA 224 101-••A	740	90.0	89.1	0.75	39.56	5.5	238	2.1	2.7
<b>22</b>	<b>M2QA 225 M8A</b>	3GQA 224 301-••A	740	90.5	88.2	0.75	46.78	6.0	283	2.2	2.7
<b>30</b>	<b>M2QA 250 M8A</b>	3GQA 254 301-••A	740	91.3	90.1	0.79	60	6.5	387	2.3	2.4
<b>37</b>	<b>M2BAT 280 SMA</b>	3GBA 284 210-••D	741	93.5	93.3	0.78	74	7.3	477	1.8	3.0
<b>45</b>	<b>M2BAT 280 SMB</b>	3GBA 284 220-••D	741	94.0	93.8	0.78	90	7.6	580	1.9	3.2
<b>55</b>	<sup>1)</sup> <b>M2BAT 280 SMC</b>	3GBA 284 230-••D	741	94.4	94.3	0.79	108	7.8	709	1.9	3.2
<b>55</b>	<b>M2BAT 315 SMA</b>	3GBA 314 210-••D	740	94.1	94.0	0.81	104	7.1	710	1.6	2.7
<b>75</b>	<b>M2BAT 315 SMB</b>	3GBA 314 220-••D	740	94.4	94.3	0.82	140	7.1	968	1.7	2.7
<b>90</b>	<b>M2BAT 315 SMC</b>	3GBA 314 230-••D	740	94.8	94.7	0.82	167	7.4	1161	1.8	2.7
<b>110</b>	<b>M2BAT 315 MLA</b>	3GBA 314 410-••D	740	95.1	95.1	0.83	202	7.3	1420	1.8	2.7
<b>132</b>	<b>M2BAT 355 S</b>	3GBA 354 100-••D	743	95.0	94.9	0.81	247	6.5	1697	1.3	2.3

<sup>1)</sup> High-output design

The two bullets in the product code indicate choice of mounting arrangement, voltage and frequency (see ordering information page).

# General purpose cast iron motors

## Technical data for totally enclosed squirrel cage three phase motors

IP 55 – IC 411 – Insulation class F, temperature rise class B

Output kW	Motor type	Speed r/min	Efficiency %	Power factor cos φ	Current I <sub>N</sub> A	Speed r/min	Efficiency %	Power factor cos φ	Current I <sub>N</sub> A	Moment of inertia J = ¼ D <sup>2</sup> kgm <sup>2</sup>	Weight kg	Sound pressure level L <sub>p</sub> dB(A)
<b>750 r/min = 8 poles</b>			<b>380 V 50 Hz</b>			<b>415 V 50 Hz</b>			<b>Basic design</b>			
0.18	M2QA 80 M8A	695	51.0	0.61	0.88	705	51.5	0.60	0.82	0.00111	16	42
0.25	M2QA 80 M8B	695	54.0	0.61	1.16	705	54.5	0.60	1.08	0.00326	17	42
0.37	M2QA 90 S8A	695	62.0	0.61	1.49	705	62.5	0.60	1.38	0.00541	21	46
0.55	M2QA 90 L8A	695	63.0	0.61	2.18	705	63.5	0.60	2.01	0.00756	24	46
0.75	M2QA 100 L8A	695	70.0	0.67	2.43	705	69.0	0.64	2.39	0.00971	31	53
1.1	M2QA 100 L8B	695	71.5	0.68	3.45	705	70.5	0.62	3.47	0.01186	34	53
1.5	M2QA 112 M8A	695	75.0	0.68	4.47	705	75.0	0.67	4.16	0.01559	42	55
2.2	M2QA 132 S8A	705	80.5	0.75	5.6	715	80.5	0.69	5.55	0.03625	56	55
3	M2QA 132 M8A	705	81.0	0.78	7.22	715	81.0	0.72	7.11	0.04141	64	56
4	M2QA 160 M8A	715	84.0	0.76	9.52	720	84.0	0.70	9.46	0.0676	105	58
5.5	M2QA 160 M8B	715	85.5	0.76	12.9	720	85.5	0.70	12.78	0.09524	125	58
7.5	M2QA 160 L8A	715	86.5	0.77	17.1	722	86.5	0.70	17.23	0.12122	142	58
11	M2QA 180 L8A	725	87.7	0.79	24.1	730	87.7	0.74	23.58	0.23645	176	61
15	M2QA 200 L8A	725	88.9	0.78	32.9	730	88.8	0.74	31.75	0.37103	235	63
18.5	M2QA 225 S8A	740	89.9	0.75	41.7	745	90.3	0.71	40.14	0.53287	290	65
22	M2QA 225 M8A	740	90.4	0.76	48.7	745	90.3	0.71	47.74	0.65825	302	65
30	M2QA 250 M8A	738	91.1	0.80	63	741	91.4	0.78	58	0.975	392	67
37	M2BAT 280 SMA	740	93.2	0.80	75	742	93.4	0.76	73	1.85	570	65
45	M2BAT 280 SMB	740	93.8	0.80	92	742	94.0	0.75	90	2.2	610	65
55	M2BAT 280 SMC	740	94.2	0.81	110	742	94.4	0.77	106	2.85	690	65
55	M2BAT 315 SMA	739	93.9	0.83	108	741	94.1	0.80	102	3.2	820	65
75	M2BAT 315 SMB	739	94.3	0.83	146	741	94.4	0.81	137	4.1	910	65
90	M2BAT 315 SMC	739	94.6	0.84	173	741	94.8	0.81	164	4.9	980	65
110	M2BAT 315 MLA	739	94.9	0.84	209	741	95.1	0.82	196	5.8	1100	72
132	M2BAT 355 S	742	94.9	0.82	258	743	95.0	0.80	244	7.3	1500	75

<sup>1)</sup> High-output design



# General purpose cast iron motors - Variant codes

Code/ Variant )	Motor size					
	71- 80	90- 100	112- 132	160- 180	200- 250	280- 355
<b>Balancing</b>						
052	Balancing to grade R (IEC 60034-14).					
	M	M	M	NA	NA	NA
424	Balancing to grade S (IEC 60034-14).					
	M	M	M	R	R	NA
417	Full key balancing.					
	M	M	M	R	R	NA
<b>Bearings and lubrication</b>						
036	Transport lock for bearings.					
	NA	NA	NA	M	M	M
037	Roller bearing at D-end.					
	NA	NA	NA	M	M	M
039	Cold resistant grease .					
	M	M	M	M	M	M
040	Heat resistant grease					
	M	M	M	M	M	M
041	Bearings regreasable via grease nipples. Frame size 250 as standard.					
	NA	NA	NA	M	M	S
043	SPM-nipples. Frame size 355 as standard.					
	NA	NA	M	NA	NA	M
<b>Branch standard designs</b>						
178	Stainless steel/acid proof bolts.					
	M	M	M	M	M	M
209	Non-standard voltage or frequency, (special winding).					
	M	M	M	M	M	NA
425	Corrosion protected stator and rotor core.					
	M	M	M	M	M	S
785	Reinforced tropicalisation.					
	S	S	S	S	S	S
<b>Cooling system</b>						
068	Metal fan.					
	M	M	M	M	M	M
183	Separate motor cooling fan (fan axial, N-end).					
	P	M	M	P	P	NA
<b>Dimension drawing</b>						
141	Binding dimension drawing.					
	M	M	M	M	M	M
<b>Drain holes</b>						
065	Plugged existing drain holes.					
	NA	NA	NA	NA	NA	M
066	Modified drain hole position (for specified IM xxxx).					
	NA	NA	NA	NA	NA	M
076	Draining holes with plugs.					
	M	M	M	M	M	S
<b>Earthing bolt</b>						
067	External earthing bolt.					
	M	M	M	M	M	M
<b>Heating elements</b>						
450	Heating element, 100-120 V.					
	M	M	M	M	M	M
451	Heating element, 200-240 V.					
	M	M	M	M	M	M
<b>Insulation system</b>						
014	Winding insulation class H.					
	P	P	P	P	P	NA
405	Special winding insulation for frequency converter supply.					
	P	P	P	P	P	NA

\*) Certain variant codes cannot be used simultaneously.

**S** = Included as standard  
**M** = On modification of a stocked motor, or on new manufacture, the number per order may be limited.

**P** = New manufacture only.  
**R** = On request.  
**NA** = Not applicable



Code/ Variant )	Motor size						
	71- 80	90- 100	112- 132	160- 180	200- 250	280- 355	
<b>Mounting arrangements</b>							
008	IM2101 foot/flange mounted, IEC flange, from IM1001(B34 from B3). Not possible for frame size 132.	M	M	M	NA	NA	NA
009	IM2001 foot/flange mounted, IEC flange, from IM1001(B35 from B3).	M	M	M	M	M	M
047	IM 3601 flange mounted, IEC flange, from IM3001 (B14 from B5). Not possible for frame size 132.	M	M	M	NA	NA	NA
078	(IM 3601) flange mounted, DIN C-flange. Larger flange than standard version. Not possible for frame size 132.	M	M	M	NA	NA	NA
090	(IM 2101) foot/flange mounted, DIN C-flange, from IM 1001 (B34 from B3). Not possible for frame size 132.	M	M	M	NA	NA	NA
<b>Painting</b>							
114	Special paint colour, standard grade.	M	M	M	M	M	M
<b>Protection</b>							
005	Protective roof, vertical motor, shaft down.	M	M	M	M	M	M
072	Radial seal at D-end.	M	M	M	M	M	M
073	Sealed against oil at D-end.	P	P	P	P	P	P
211	Weather protected, IP xx W.	M	M	M	M	M	NA
401	Protective roof, horizontal motor.	M	M	M	M	M	M
403	Degree of protection IP56.	M	M	M	M	M	NA
158	Degree of protection IP65.	M	M	M	M	M	NA
<b>Rating &amp; instruction plates</b>							
001	Restamping voltage and output from 50 to 60 Hz or from 60 to 50 Hz.	M	M	M	M	M	M
002	Restamping voltage, frequency and output, continuous duty.	M	M	M	M	M	M
013	Restamping to output for class F temperature rise.	M	M	M	M	M	M
095	Restamping output (maintained voltage, frequency) intermittent duty.	M	M	M	M	M	M
138	Mounting of additional identification plate.	M	M	M	M	M	M
139	Additional identification plate delivered loose.	M	M	M	M	M	M
161	Additional rating plate delivered loose.	M	M	M	M	M	M
212	Restamping to output for class B temperature rise.	M	M	M	M	M	M
<b>Stator winding temperature sensors</b>							
121	Bimetal detectors, break type (NCC), (3 in series), 130°C, in stator winding.	M	M	M	M	M	M
122	Bimetal detectors, break type (NCC), (3 in series), 150°C, in stator winding.	M	M	M	M	M	M
123	Bimetal detectors, break type (NCC), (3 in series), 170°C, in stator winding.	M	M	M	M	M	M
125	Bimetal detectors, break type (NCC), (2x3 in series), 150°C, in stator winding.	M	M	M	M	M	M
127	Bimetal detectors, break type (NCC), (3 in series, 130°C, & 3 in series, 150°C), in stator winding.	M	M	M	M	M	M

\*) Certain variant codes cannot be used simultaneously.

**S** = Included as standard  
**M** = On modification of a stocked motor, or on new  
manufacture, the number per order may be limited.

**P** = New manufacture only.  
**R** = On request.  
**NA** = Not applicable

Code/Variant )	Motor size					
	71-80	90-100	112-132	160-180	200-250	280-355
321 Bimetal detectors, closing type (NO), (3 in parallel), 130°C, in stator winding.	M	M	M	M	M	M
322 Bimetal detectors, closing type (NO), (3 in parallel), 150°C, in stator winding.	M	M	M	M	M	M
323 Bimetal detectors, closing type (NO), (3 in parallel), 170°C, in stator winding.	M	M	M	M	M	M
325 Bimetal detectors, closing type (NO), (2x3 in parallel), 150°C, in stator winding.	M	M	M	M	M	M
327 Bimetal detectors, closing type (NO), (3 in parallel, 130°C, & 3 in parallel 150°C), in stator winding.	M	M	M	M	M	M
435 PTC-thermistors (3 in series), 130°C, in stator winding.	M	M	M	M	M	M
436 PTC-thermistors (3 in series), 150°C, in stator winding.	M	M	M	S	S	S
437 PTC-thermistors (3 in series), 170°C, in stator winding.	M	M	M	M	M	M
439 PTC-thermistors (2x3 in series), 150°C, in stator winding.	M	M	M	M	M	M
441 PTC-thermistors (3 in series 150°C & 3 in series 150°C, in stator winding.	M	M	M	M	M	M
442 PTC-thermistors (3 in series 150°C & 3 in series 150°C, in stator winding.	M	M	M	M	M	M
445 Pt100 (1per phase) in stator winding. Only for frame size 80.	M	M	M	M	M	M
446 Pt100 (2 per phase) in stator winding.	-	-	-	M	M	M
<b>Terminal box</b>						
015 Motor supplied in D-connection.	M	M	M	M	M	M
017 Motor supplied in Y-connection.	M	M	M	M	M	M
021 Terminal box LHS, seen from D-end (= L in product code).	P	P	P	P	P	NA
137 Extended cable connection, low terminal box.	P	P	P	P	P	NA
157 Terminal box degree of protection IP65.	M	M	M	M	M	M
180 Terminal box RHS, seen from D-end (= R in product code).	M	M	M	M	M	NA
230 One standard cable gland or cable box.	M	M	M	M	M	S
231 Standard cable glands with clamping device.	M	M	M	M	M	R
400 4 x 90 degrees turnable terminal box.	S	S	S	M	M	NA
418 Separate terminal box for temperature detectors.	M	M	M	P	P	M
467 Lower than standard terminal box and rubber extended cable, length 2 m included.	P	P	P	P	P	NA
468 Cable entry from D-end.	M	M	M	M	M	M
469 Cable entry from N-end.	M	M	M	NA	NA	NA
731 Two standard cable glands.	M	M	M	M	M	S
<b>Testing</b>						
145 Type test report from test of identical motor.	M	M	M	M	M	M
146 Type test with report for motor from specific delivery batch.	R	R	R	R	R	P
148 Routine test report.	M	M	M	M	M	M
760 Vibration level test.	M	M	M	M	M	M
762 Noise level test.	NA	NA	NA	NA	NA	M

\*) Certain variant codes cannot be used simultaneously.

**S** = Included as standard  
**M** = On modification of a stocked motor, or on new manufacture, the number per order may be limited.

**P** = New manufacture only.  
**R** = On request.  
**NA** = Not applicable

# General purpose cast iron motors

# Sizes 71-132

## Dimension drawings

Foot-mounted; IM B3 (IM 1001), IM B6 (IM 1011), IM B7 (IM 1061), IM B8 (IM 1071), IM V5 (IM 1011), IM V6 (IM 1031)

### Three phase motor, foot-mounted, terminal box top-mounted

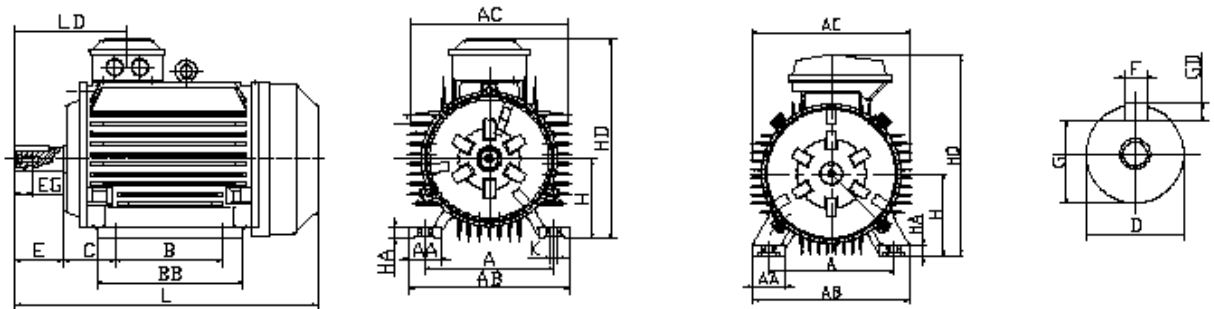

### Three phase motor, foot-mounted, terminal box on right hand side

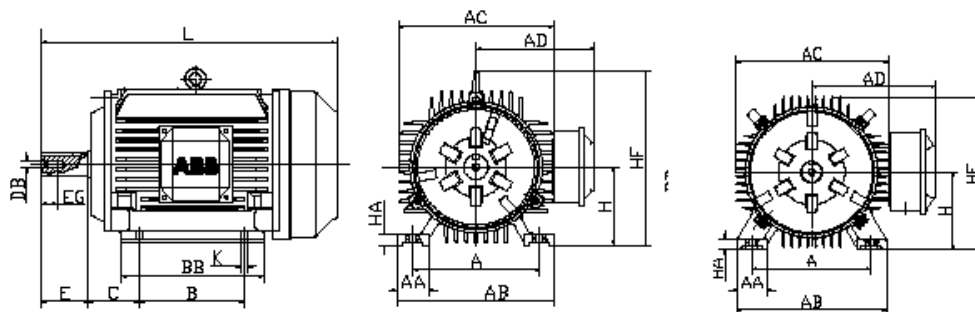

Motor size	Poles	A	AA	AB	AC	AD	B	BB	C	D	DB	E	EG
71M	2-6	112	30	145	145	120	90	110	45	14	M5	30	12.5
80M	2-6	125	35	160	165	145	100	135	50	19	M6	40	16
90S	2-6	140	35	175	180	150	100	140	56	24	M8	50	19
90L	2-6	140	35	175	180	150	125	165	56	24	M8	50	19
100L	2-6	160	40	200	205	175	140	180	63	28	M10	60	22
112M	2-8	190	50	235	225	185	140	190	70	28	M10	60	22
132S	2-8	216	55	270	265	205	140	205	89	38	M12	80	28
132M	2-8	216	55	270	265	205	178	240	89	38	M12	80	28

Motor size	Poles	F	G	GD	H	HA	HD	HF	K	L	LD
71 M	2-6	5	11	5	71	10	200	-	7	255	100
80 M	2-6	6	15.5	6	80	12	225	170	10	285	116
90 S	2-6	8	20	7	90	12	240	185	10	310	128
90 L	2-6	8	20	7	90	12	240	185	10	335	128
100 L	2-6	8	24	7	100	14	275	245	12	380	144
112 M	2-6	8	24	7	112	15	290	265	12	380	144
132 S	2-6	10	33	8	132	18	335	300	12	465	169
132 M	2-6	10	33	8	132	18	335	300	12	505	169

Tolerances:

A, B, C +, - 0.8      H + 0, - 0.5  
 D, DA ISO m6      N ISO j6  
 F, FA ISO h9

Above table gives the main dimensions in mm.

For detailed drawings please see our web-pages 'www.abb.com/motors&drives' or contact us.



## Dimension drawings

Flange-mounted; IM B5 (IM 3001), IM V1 (IM 3001), IM V3 (IM 3031)  
IM B14 (IM 3601), IM V18 (IM 3611), IM V19 (IM 3631)

### Three phase motor, flange-mounted

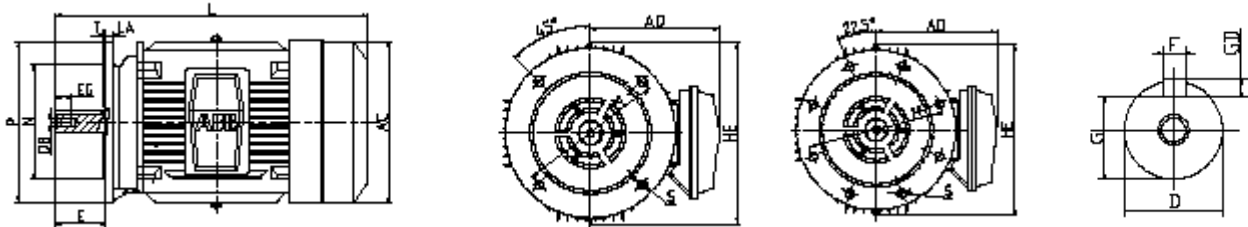

### Three phase motor, flange-mounted, small flange (B14)

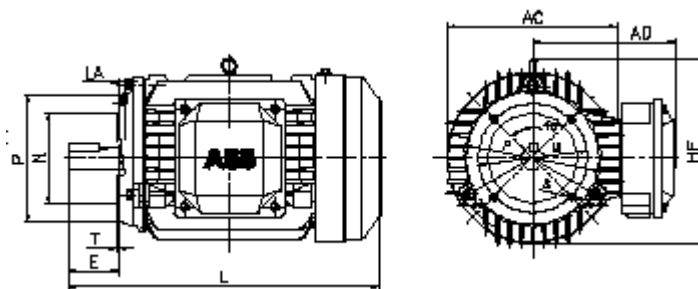

### IM B5 (IM3001), IM V1 (IM3011), IM V3 (IM3031)

Type	Poles	AC	AD	D	DB	E	EG	F	G	GD	HE	L	LA	M	N	P	S	T
<b>M2QA</b>																		
71M	2-6	145	120	14	M5	30	12.5	5	11	5	165	255	9	130	110	160	10	3.5
80M	2-8	165	145	19	M6	40	16	6	15.5	6	200	285	9	165	130	200	12	3.5
90S	2-8	180	150	24	M8	50	19	8	20	7	200	310	10	165	130	200	12	3.5
90L	2-8	180	150	24	M8	50	19	8	20	7	200	335	10	165	130	200	12	3.5
100L	2-8	205	175	28	M10	60	22	8	24	7	265	380	11	215	180	250	15	4
112M	2-8	225	185	28	M10	60	22	8	24	7	270	395	11	215	180	250	15	4
132S	2-8	265	205	38	M12	80	28	10	33	8	320	465	12	265	230	300	15	4
132M	2-8	265	205	38	M12	80	28	10	33	8	320	505	12	265	230	300	15	4

### IM B14 (IM3611), IM V19 (IM3631)

Motor size	Poles	Flange size	HE	P	M	N	S	T
71M	2-6	C105	145	105	85	70	M6	2.5
		C140	145	140	115	95	M8	3
80M	2-8	C120	165	120	100	80	M6	3
		C160	165	160	130	110	M8	3.5
90S	2-8	C140	185	140	115	95	M8	3
		C160	185	160	130	110	M8	3.5
90L	2-8	C140	185	140	115	95	M8	3
		C160	185	160	130	110	M8	3.5
100L	2-8	C160	255	160	130	110	M8	3.5
		C200	255	200	165	130	M10	3.5
112M	2-8	C160	265	160	130	110	M8	3.5
		C200	265	200	165	130	M10	3.5

Tolerances:

D, DA ISO m6  
F, FA ISO h9  
N ISO j6

Above table gives the main dimensions in mm.

For detailed drawings please see our web-pages '[www.abb.com/motors&drives](http://www.abb.com/motors&drives)' or contact us.

# General purpose cast iron motors

# Sizes 71-132

## Dimension drawings

Foot- and flange-mounted; M B35 (IM 2001), IM V15 (IM 2011), IM V 36 (IM 2031)

Three phase motor, foot- and flange-mounted, terminal box top-mounted

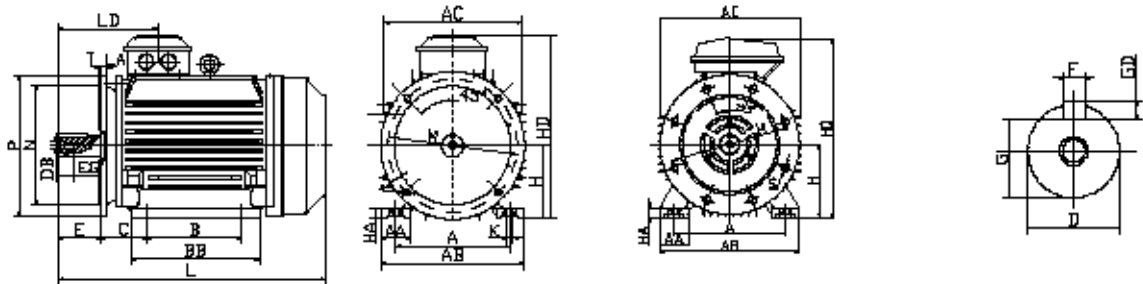

Three phase motor, foot- and flange-mounted, terminal box on right

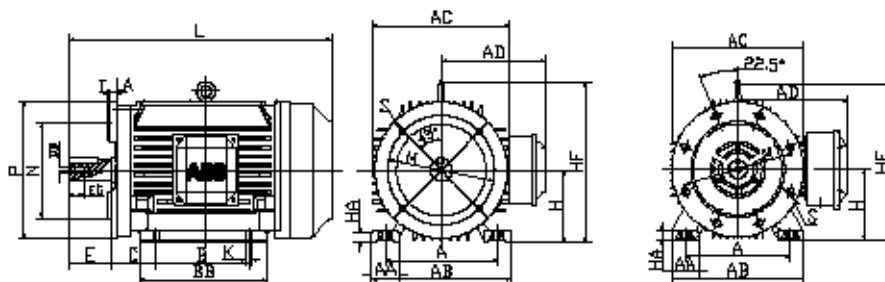

Motor size	Poles	A	AA	AB	AC	AD	B	BB	C	D	DB	E	EG	F
71M	2-6	112	30	145	145	120	90	110	45	14	M5	30	12.5	5
80M	2-8	125	35	160	165	145	100	135	50	19	M6	40	16	6
90S	2-8	140	35	175	180	150	100	140	56	24	M8	50	19	8
90L	2-8	140	35	175	180	150	125	165	56	24	M8	50	19	8
100L	2-8	160	40	200	205	175	140	180	63	28	M10	60	22	8
112M	2-8	190	50	235	225	185	140	190	70	28	M10	60	22	8
132S	2-8	216	55	270	265	205	140	205	89	38	M12	80	28	10
132M	2-8	216	55	270	265	205	178	240	89	38	M12	80	28	10

Motor size	Poles	G	GD	H	HA	HD	HF	K	L	LA	LD	M	N	P	S	T
71M	2-6	11	5	71	10	200	-	7	255	9	100	130	110	160	10	3.5
80M	2-8	15.5	6	80	12	225	170	10	285	9	116	165	130	200	12	3.5
90S	2-8	20	7	90	12	240	185	10	310	10	128	165	130	200	12	3.5
90L	2-8	20	7	90	12	240	185	10	335	10	128	165	130	200	12	3.5
100L	2-8	24	7	100	14	275	245	12	380	11	138	215	180	250	15	4
112M	2-8	24	7	112	15	290	265	12	395	11	144	215	180	250	15	4
132S	2-8	33	8	132	18	335	300	12	465	12	169	265	230	300	15	4
132M	4-8	33	8	132	18	335	300	12	505	12	169	265	230	300	15	4

Tolerances:

A, B, C	+/- 0.8	H + 0, -0.5
D, DA	ISO m6	N ISO j6
F, FA	ISO h9	

Above table gives the main dimensions in mm.

For detailed drawings please see our web-pages '[www.abb.com/motors&drives](http://www.abb.com/motors&drives)' or contact us.

# General purpose cast iron motors

# Sizes 160-250

## Dimension drawings

Foot-mounted; IM B3 (IM 1001), IM B6 (IM 1051), IM B7 (IM 1061), IM B8 (IM 1071), IM V5 (IM 1011), IM V6 (IM 1031)

Three phase motor, foot-mounted, terminal box top-mounted

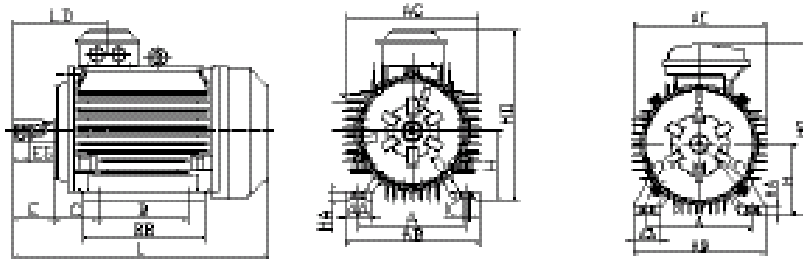

Three phase motor, foot-mounted, terminal box on right hand side

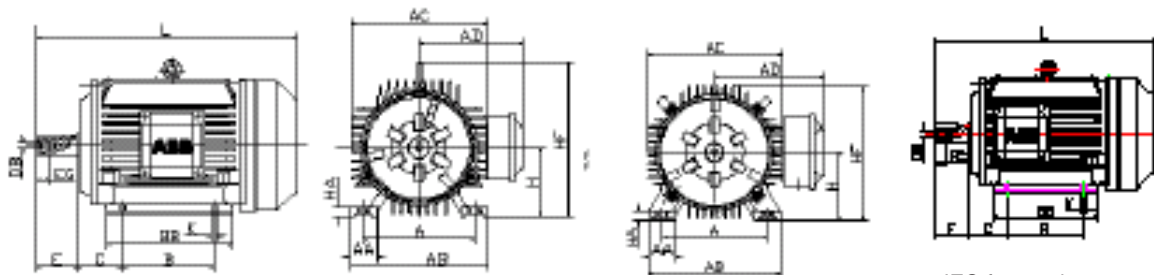

IEC-frame size 250

Motor size	Poles	A	AA	AB	AC	AD	B	BB	C	D	DB	E	EG
160 M	2-8	254	60	325	330	255	210	265	108	42	M16	110	36
160 L	2-8	254	60	325	330	255	254	310	108	42	M16	110	36
180 M	2-4	279	70	350	355	270	241	315	121	48	M16	110	36
180 L	4-8	279	70	350	350	270	279	350	121	48	M16	110	36
200 L	2-8	318	70	390	395	305	305	380	133	55	M20	110	39
225 S	4-8	356	75	435	440	335	286	380	149	60	M20	140	39
225 M	2	356	75	435	450	335	311	405	149	55	M20	110	39
225 M	4-8	356	75	435	450	335	311	405	149	60	M20	140	39
250 M	2	406	80	490	515	395	349	455	168	60	M20	140	39
250 M	4-8	406	80	490	515	395	439	455	168	55	M20	140	39

Motor size	Poles	F	G	GD	H	HA	HD	HF	K	L	LD
160 M	2-8	12	47	8	160	22	415	380	15	600	250
160 L	2-8	12	47	8	160	22	415	380	15	645	250
180 M	2-4	14	42.5	9	180	22	450	420	15	670	270
180 L	4-8	14	42.5	9	180	22	450	420	15	710	270
200 L	2-8	16	49	10	200	25	510	470	19	770	285
225 S	4-8	18	53	11	225	28	560	520	19	820	340
225 M	2	16	49	10	225	28	560	520	19	815	310
225 M	4-8	18	53	11	225	28	560	520	19	840	340
250 M	2	18	53	11	250	30	645	580	24	930	360
250 M	4-8	18	58	11	250	30	645	580	24	930	360

Tolerances:

A, B, C	+, - 0.8	F, FA	ISO h0
D, DA	ISO k6 < Ø 50 mm	H	+ 0, - 0.5
	ISO h9 > Ø 50 mm		

Above table gives the main dimensions in mm.

For detailed drawings please see our web-pages '[www.abb.com/motors&drives](http://www.abb.com/motors&drives)' or contact us.

## Dimension drawings

Flange-mounted; IM B5 (IM 3001), IM V1 (IM 3011), IM V3 (IM 3031),  
IM B14 (IM 3601), IM V18 (IM 3611), IM V19 (IM 3631)

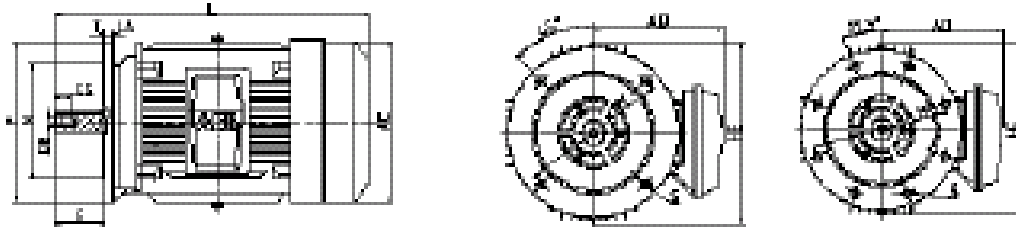

Motor size	Poles	AD	D	DB	E	EG	F	G	GD	HE	L	LA	M	N	P	S	T
160 M	2-8	255	42	M16	110	36	12	47	8	400	600	15	300	250	350	19	5
160 L	2-8	255	42	M16	110	36	12	47	8	400	645	15	300	250	350	19	5
180 M	2-4	270	48	M16	110	36	14	42.5	9	420	670	18	300	250	350	19	5
180 L	4-8	270	48	M16	110	36	14	42.5	9	420	710	18	300	250	350	19	5
200 L	2-8	305	55	M20	110	39	16	49	10	470	770	20	350	300	400	19	5
225 S	4-8	335	60	M20	140	39	18	53	11	520	820	20	400	350	450	19	5
225 M	2	335	55	M20	110	39	16	49	10	520	815	20	400	350	450	19	5
225 M	4-8	335	60	M20	140	39	18	53	11	520	840	20	400	350	450	19	5
250 M	2	395	60	M20	140	39	18	53	11	655	930	22	500	450	550	19	5
250 M	4-8	395	65	M20	140	39	18	53	11	655	930	22	500	450	550	19	5

**Tolerances:**

D, DA	ISO k6 < Ø 50 mm
	ISO m6 > Ø 50 mm
F, FA	ISO h9
N	ISO j6

Above table gives the main dimensions in mm.  
For detailed drawings please see our web-pages  
'[www.abb.com/motors&drives](http://www.abb.com/motors&drives)' or contact us.

# General purpose cast iron motors

# Sizes 160-250

## Dimension drawings

Foot- and flange-mounted; IM B35 (IM 2001), IM V15 (IM 2011), IM V36 (IM 2031)

Three phase motor, foot-mounted, terminal box top-mounted

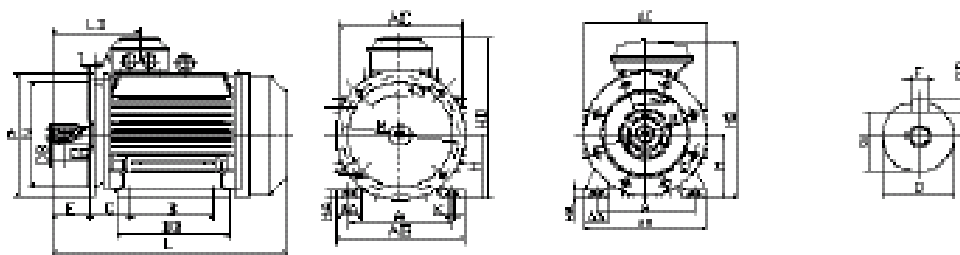

Three phase motor, foot-mounted, terminal box on right hand side

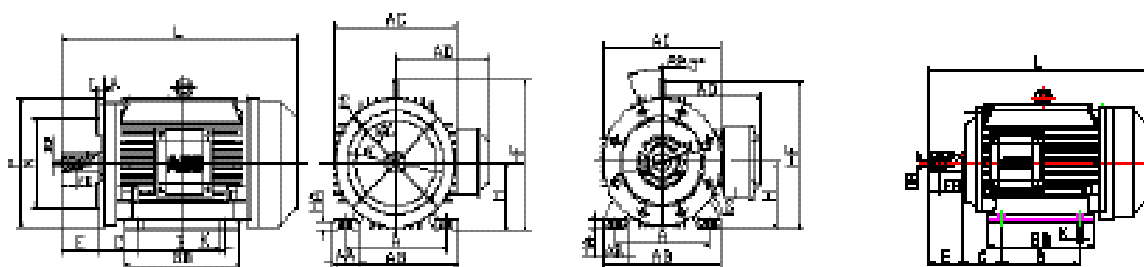

IEC frame size 250

Motor size	Poles	A	AA	AB	AC	AD	B	BB	C	D	DB	E	EG	F	G
160 M	2-8	254	60	325	330	255	210	265	108	42	M16	110	36	12	47
160 L	2-8	254	60	325	330	255	254	310	108	42	M16	110	36	12	47
180 M	2-4	279	70	350	355	270	241	315	121	48	M16	110	36	14	42.5
180 L	4-8	279	70	350	350	270	279	350	121	48	M16	110	36	14	42.5
200 L	2-8	318	70	390	395	305	305	380	133	55	M20	110	39	16	49
225 S	4-8	356	75	435	440	335	286	380	149	60	M20	140	39	18	53
225 M	2	356	75	435	450	335	311	405	149	55	M20	110	39	18	49
225 M	4-8	356	75	435	450	335	311	405	149	60	M20	140	39	18	53
250 M	2	406	80	490	515	395	349	455	168	60	M20	140	39	18	53
250 M	4-8	406	80	490	515	395	439	455	168	55	M20	140	39	18	53

Motor size	Poles	GD	H	HA	HD	HF	K	L	LA	LD	M	N	P	S	T
160 M	2-8	8	160	22	415	380	15	600	15	250	300	250	350	19	5
160 L	2-8	8	160	22	415	380	15	645	15	250	300	250	350	19	5
180 M	2-4	9	180	22	450	420	15	670	18	270	300	250	350	19	5
180 L	4-8	9	180	22	450	420	15	710	18	270	300	250	350	19	5
200 L	2-8	10	200	25	510	470	19	770	20	285	350	300	400	19	5
225 S	4-8	11	225	28	560	520	19	820	20	340	400	350	450	19	5
225 M	2	10	225	28	560	520	19	815	20	310	400	350	450	19	5
225 M	4-8	11	225	28	560	520	19	840	20	340	400	350	450	19	5
250 M	2	11	250	30	645	580	24	930	22	360	500	450	550	19	5
250 M	4-8	11	250	30	645	580	24	930	22	360	500	450	550	19	5

Tolerances:

A, B, C	+ , - 0.8	F, FA	ISO h9
D, DA	ISO k6 > Ø 50 mm	H	+ 0, - 0.5
	ISO m6 > Ø 50 mm	N	ISO j6

Above table gives the main dimensions in mm.

For detailed drawings please see our web-pages '[www.abb.com/motors&drives](http://www.abb.com/motors&drives)' or contact us.



# General purpose cast iron motors

# Sizes 280-315

## Dimension drawings

Foot-mounted; IM B3 (IM 1001), IM B6 (IM 1051), IM B7 (IM 1061), IM B8 (IM 1071), IM V5 (IM 1011), IM V6 (IM 1031)

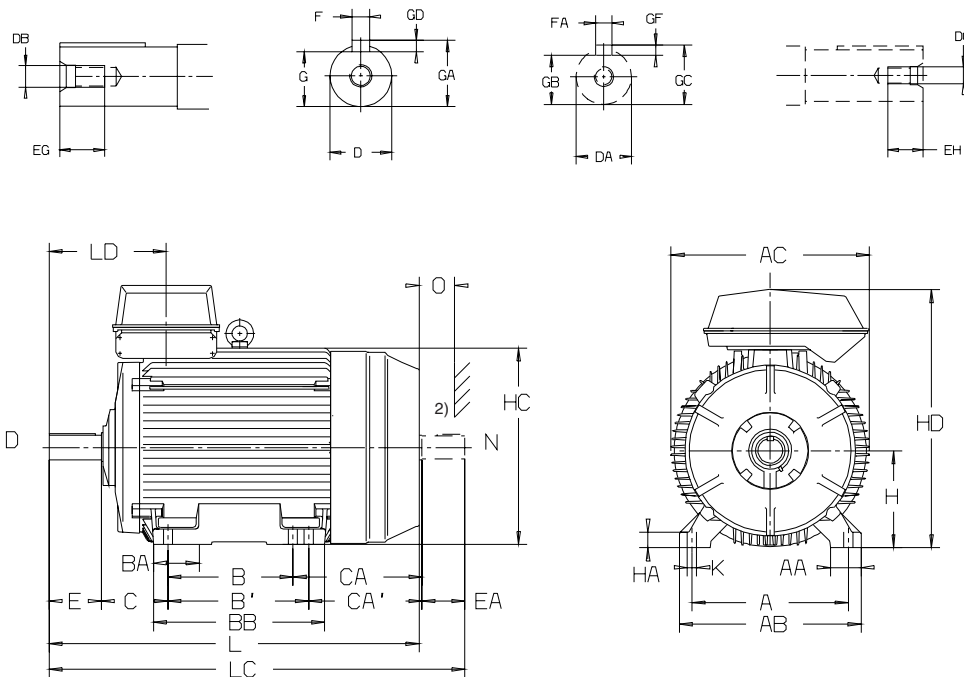

Motor size	Poles	A	AA	AB	AC	B	B'	BA	BB	C	CA	CA'	D	DA	DB	DC	E	EA	EG	EH
280 SM <sub>2</sub>	2	457	85	530	572	368	419	146	506	190	400	349	65	60	M20	M20	140	140	40	40
	4-12	457	85	530	572	368	419	146	506	190	400	349	75	65	M20	M20	140	140	40	40
315 SM <sub>2</sub>	2	508	100	590	645	406	457	163	556	216	465	414	65	60	M20	M20	140	140	40	40
	4-12	508	100	590	645	406	457	163	556	216	465	414	80	75	M20	M20	170	140	40	40
315 ML <sub>2</sub>	2	508	100	590	645	457	508	163	607	216	465	414	65	60	M20	M20	140	140	40	40
	4-12	508	100	590	645	457	508	163	607	216	465	414	90	75	M24	M20	170	140	48	40
355 <sub>2</sub>	2	610	120	700	740	500	-	161	662	254	460	-	70	70	M20	M20	140	140	40	40
	4-12	610	120	700	740	500	-	161	662	254	460	-	100	90	M24	M24	210	170	48	48

Motor size	Poles	F	FA	G	GA	GB	GC	GD	GF	H	HA	HC	HD	K	L	LA	LC	LD	O <sup>1)</sup>
280 SM <sub>2</sub>	2	18	18	58	69	53	64	11	11	280	40	566	745	24	1088	22	1238	332	100
	4-12	20	18	67.5	79.5	58	69	12	11	280	40	566	745	24	1088	22	1238	332	100
315 SM <sub>2</sub>	2	18	18	58	69	53	64	11	11	315	50	638	840	30	1218	25	1367	351	115
	4-12	22	20	71	85	67.5	79.5	14	12	315	50	638	840	30	1248	25	1397	381	115
315 ML <sub>2</sub>	2	18	18	58	69	53	64	11	11	315	50	638	840	30	1269	25	1418	351	115
	4-12	25	20	84	95	67.5	79.5	14	12	315	50	638	840	30	1299	25	1448	381	115
355 S <sub>2</sub>	2	20	20	62.5	74.5	62.5	74.5	12	12	355	55	725	955	35	1344	25	1494	397	130
	4-12	28	25	90	106	81	95	16	14	355	55	725	955	35	1414	25	1594	467	130

Tolerances:

D, DA ISO M6

H +0, -1.0

<sup>1)</sup> Cooling distance.

<sup>2)</sup> Second shaft end on request.

Above table gives the main dimensions in mm.

For detailed drawings please see our web-pages '[www.abb.com/motors&drives](http://www.abb.com/motors&drives)' or contact us.

## Dimension drawings

Flange-mounted; IM B5 (IM 3001), IM V1 IM 3001), IM V3 (IM 3031)  
IM B14 (IM 3601), IM V18 (IM 3611), IM V19 (IM 3631)

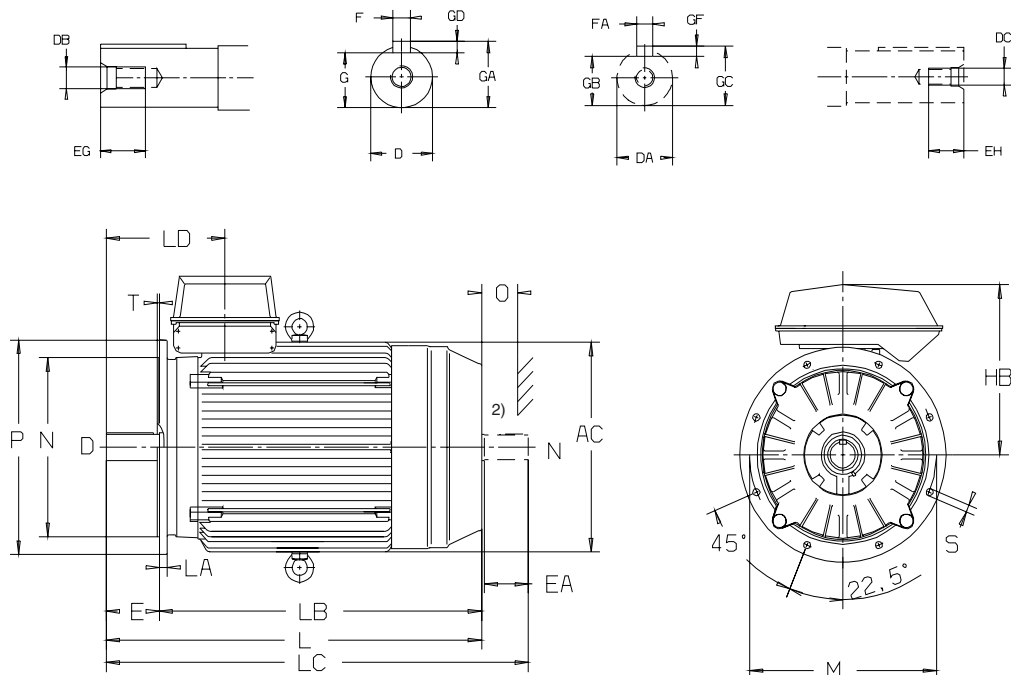

Motor size	Poles	AC	D	DA	DB	DC	E	EA	EG	EH	F	FA	G	GA	GB	GC	GD	GF
280 SM_	2	572	65	60	M20	M20	140	140	40	40	18	18	58	69	53	64	11	11
	4-12	572	75	65	M20	M20	140	140	40	40	20	18	67.5	79.5	58	69	12	11
315 SM_	2	645	65	60	M20	M20	140	140	40	40	18	18	58	69	53	64	11	11
	4-12	645	80	75	M20	M20	170	140	40	40	22	20	71	85	67.5	79.5	14	12
315 ML_	2	645	65	60	M20	M20	140	140	40	40	18	18	58	69	53	64	11	11
	4-12	645	90	75	M24	M20	170	140	48	40	25	20	81	95	67.5	79.5	14	12
355 S_	2	746	70	70	M20	M20	140	140	40	40	20	20	62.5	74.5	62.5	74.5	12	12
	4-12	645	100	90	M24	M24	210	170	48	48	28	25	90	106	81	95	16	14

Motor size	Poles	HB	L	LA	LB	LC	LD	M	N	O	P	S	T
280 SM_	2	465	1088	22	938	1238	332	500	450	100	550	18	5
	4-12	465	1088	22	938	1238	332	500	450	100	550	18	5
315 SM_	2	525	1218	25	1078	1367	351	600	550	115	660	23	6
	4-12	525	1248	25	1078	1397	381	600	550	115	660	23	6
315 ML_	2	525	1269	25	1129	1418	351	600	550	115	660	23	6
	4-12	525	1299	25	1199	1448	381	600	550	115	660	23	6
355 S_	2	600	1344	25	1204	1494	397	740	680	130	800	23	6
	4-12	600	1414	25	1204	1594	467	740	680	130	800	23	6

Tolerances:

D, DA ISO M6  
F ISO h9  
H +0, -1.0  
N ISO j6 (280)  
ISO js6 (315)

<sup>1)</sup> Cooling distance.  
<sup>2)</sup> Second shaft end on request.

Above table gives the main dimensions in mm.

For detailed drawings please see our web-pages  
'[www.abb.com/motors&drives](http://www.abb.com/motors&drives)' or contact us.

# General purpose cast iron motors

# Sizes 280-355

## Dimension drawings

Foot- and flange-mounted; M B35 (IM 2001), IM V15 (IM 2011), IM V 36 (IM 2031)

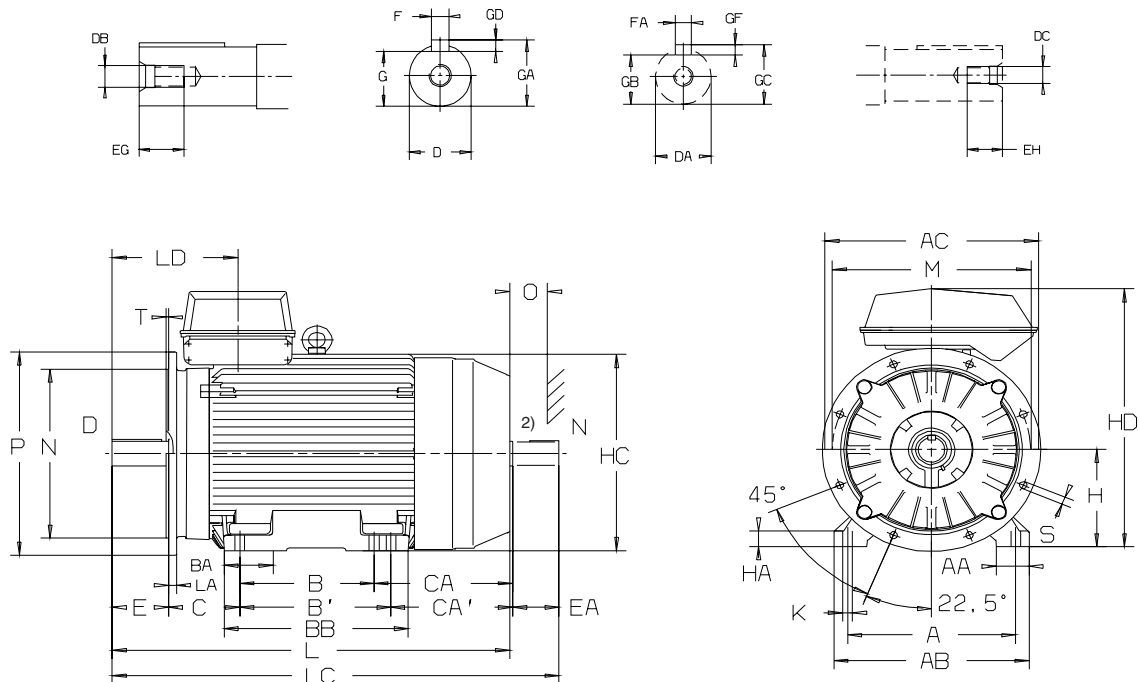

Motor size	Poles	A	AA	AB	AC	B	B'	BA	BB	C	CA	CA'	D	DA	DB	DC	E	EA	EG	EH	F	FA
280 SM_2	2	457	85	530	572	368	419	146	506	190	400	349	65	60	M20	M20	140	140	40	40	18	18
	4-12	457	85	530	572	368	419	146	506	190	400	349	75	65	M20	M20	140	140	40	40	20	18
315 SM_2	2	508	100	590	645	406	457	163	556	216	465	414	65	60	M20	M20	140	140	40	40	18	18
	4-12	508	100	590	645	406	457	163	556	216	465	414	80	75	M20	M20	170	140	40	40	22	20
315 ML_2	2	508	100	590	645	457	508	163	607	216	465	414	65	60	M20	M20	140	140	40	40	18	18
	4-12	508	100	590	645	457	508	163	607	216	465	414	90	75	M24	M20	170	140	48	40	25	20
355_	2	610	120	700	740	500	-	161	662	254	460	-	70	70	M20	M20	140	140	40	40	20	20
	4-12	610	120	700	740	500	-	161	662	254	460	-	100	90	M24	M24	210	170	48	48	28	25

Motor size	Poles	G	GA	GB	GC	GD	GF	H	HA	HC	HD	K	L	LA	LC	LD	M	N	P	S	T	O
280 SM_2	2	58	69	53	64	11	11	280	40	566	745	24	1088	22	1238	332	500	450	550	18	5	100
	4-12	67.5	79.5	58	69	12	11	280	40	566	745	24	1088	22	1238	332	500	450	550	18	5	100
315 SM_2	2	58	69	53	64	11	11	315	50	638	840	30	1218	25	1367	351	600	550	660	23	6	115
	4-12	71	85	67.5	79.5	14	12	315	50	638	840	30	1248	25	1397	381	600	550	660	23	6	115
315 ML_2	2	58	69	53	64	11	11	315	50	638	840	30	1269	25	1418	351	600	550	660	23	6	115
	4-12	84	95	67.5	79.5	14	12	315	50	638	840	30	1299	25	1448	381	600	550	660	23	6	115
355 S_	2	62.5	74.5	62.5	74.5	12	12	355	55	725	955	35	1344	25	1494	397	645	740	680	23	6	130
	4-12	90	106	81	95	16	14	355	55	725	955	35	1414	25	1594	467	715	740	680	23	6	130

Tolerances:

D, DA ISO M6  
 F ISO h9  
 H +0, -1.0  
 N ISO j6 (280)  
 ISO js6 (315)

<sup>1)</sup> Cooling distance.

<sup>2)</sup> Second shaft end on request.

Above table gives the main dimensions in mm.

For detailed drawings please see our web-pages  
 'www.abb.com/motors&drives' or contact us.

# Rating plates

For motor sizes 71 to 132 the rating plate gives one current value for the voltage area. That is the highest current that can occur within the voltage area with the given output.

For motor sizes 160 to 355 the rating plate is in table form giving values for speed, current and power factor for six voltages.

## Motor sizes 71 to 132

<b>ABB</b>		ABB Motors			<b>CE</b>	
3~motor M2QA 90 S2 A					IEC 34-1	
3GQA091101-ASA				EFF2		
6205/C3		6205/C3		IP 55		
Ins.cl F		Ins.cl F		Ins.cl F		
V	Hz	r/min	kW	cos φ	A	
220-240Δ	50	2850	1.5	0.87	5.58	
380-420Y	50	2850	1.5	0.87	3.23	
440-480Y	60	3420	1.73	0.87	3.30	
No 329 11117711				21 kg		

## Motor sizes 160 to 250

<b>ABB</b>		ABB Motors			<b>CE</b>		
3 ~ motor M2QA 180 L4A					EFF2		
IEC 180 L 48					↔		
S1			No 292229936				
Cert.no			Ins.cl. F		IP 55		
V	Hz	kW	r/min	A	cos φ	IA/IN	tE/s
690 Y	50	22	1470	22.86	0.88		
400 Δ	50	22	1470	39.44	0.88		
660 Y	50	22	1465	23.37	0.90		
380 Δ	50	22	1465	40.59	0.90		
415 Δ	50	22	1475	38.90	0.86		
440 Δ	60	25.3	1764	40.06	0.89		
Cat. no 3GQA 182 501 - ADA							
6310/C3		6210/C3		186 kg			
IEC 34-1							

## Motor sizes 280 to 355

<b>CE</b>		ABB Oy, Electrical Machines			<b>CE</b>	
LV Motors, Vaasa, Finland						
3~Motor M2BAT 315SMB 6 B6						
IEC 315 S/M 80					↔	
S1		No. 0230-060100089				
		Ins.cl. F		IP 55		
V	Hz	kW	r/min	A	cos φ	Duty
690 Y	50	90	991	96	0.83	
400 D	50	90	991	166	0.83	
660 Y	50	90	990	100	0.84	
380 D	50	90	990	174	0.84	
415 D	50	90	992	163	0.81	
440 D	60	103	1190	170	0.84	
Prod.code 3GBA313220-ADD						
6319/C3		6316/C3		870 kg		
<b>ABB</b>		IEC 60034-1				

4

# Motor construction

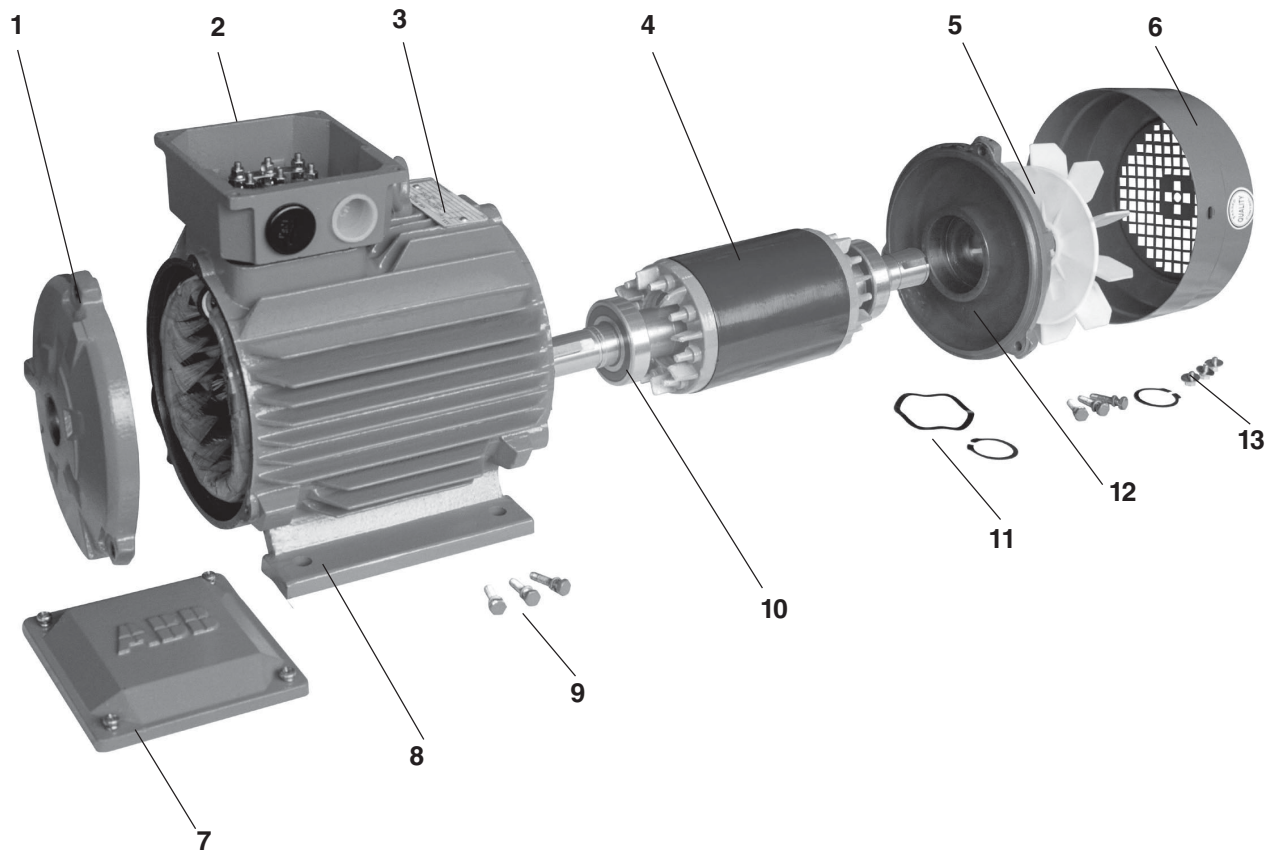

- 1 Endshield, D-end
- 2 Terminal box
- 3 Rating plate
- 4 Rotor
- 5 Fan
- 6 Fan cover
- 7 Terminal box cover

- 8 Stator
- 9 Bolt
- 10 Bearing
- 11 Wave-shape spring ring
- 12 Endshield, N-end
- 13 Screw

# General purpose cast iron motors in brief, basic design

Motor size		71	80	90	100	112	132	160
<b>Stator</b>	Material	Cast iron HT150 GB5675-85						
	Paint colour shade	Blue, Munsell 8B 4.5/3.25 / NCS 4822 B05G						
	Paint thickness	Two-pack 821 Acid Polyurethane Lacquer Enamel, thickness $\geq 60 \mu\text{m}$						
<b>Bearing end shields</b>	Material	Cast iron HT150 GB5675-85						
	Paint colour shade	Blue, Munsell 8B 4.5/3.25 / NCS 4822 B05G						
	Paint thickness	Two-pack 821 Acid Polyurethane Lacquer Enamel, thickness $\geq 60 \mu\text{m}$						
<b>Bearings</b>	D-end	6202 DDU C3	6204 DDU C3	6205 DDU C3	6206 DDU C3	6207 DDU C3	6208 DDUC3	6309 DDU C3
	N-end	6202 DDU C3	6204 DDU C3	6205 DDU C3	6206 DDU C3	6206 DDU C3	6207 DDU C3	6209 DDU C3
<b>Axially-locked bearings</b>	Inner bearing cover	As standard, locked at D-end						
<b>Lubrication</b>		Greased for life.						
<b>Rating plate</b>	Material	Stainless steel						
<b>Terminal box</b>	Frame material	Cast iron HT150 GB5675-85						
	Cover material	Cast iron HT150 GB5675-85						
<b>Connections</b>	Cable entries	2xM16x1.5	2xM25x1.5	2xM32x1.5	2xM32x1.5	2xM32x1.5	2xM32x1.5	2xM40x1.5
	Terminals	6 terminals for connection						
<b>Fan</b>	Material	Reinforced glass fiber						
<b>Fan cover</b>	Material	Steel						
	Paint colour shade	Blue, Munsell 8B 4.5/3.25 / NCS 4822 B05G						
	Paint thickness	Two-pack 821 Acid Polyurethane Lacquer Enamel, thickness $\geq 60 \mu\text{m}$						
<b>Stator winding</b>	Material	Copper						
	Insulation	Insulation class F						
	Winding protection	On request						
<b>Rotor winding</b>	Material	Pressure die-cast aluminium						
<b>Balancing method</b>		Half key balancing as standard						
<b>Key ways</b>		Open key way						
<b>Enclosure</b>		IP 55						
<b>Cooling method</b>		IC 411						

4

# General purpose cast iron motors in brief, basic design

Motor size		180	200	225	250	280	315	355	
<b>Stator</b>	Material	Cast iron HT150 GB5675-85				Cast iron GG 20/GRS 200			
	Paint colour shade	Blue, Munsell 8B 4.5/3.25 / NCS 4822 B05G							
	Paint thickness	Two-pack 821 Acid Polyurethane Lacquer Enamel, thickness $\geq 60 \mu\text{m}$				Two-pack epoxy paint, thickness $\geq 70 \mu\text{m}$			
<b>Bearing end shields</b>	Material	Cast iron HT150 GB5675-85				Cast iron GG 20/GRS 200, except flange-mounted			
	Paint colour shade	Blue, Munsell 8B 4.5/3.25 / NCS 4822 B05G							
	Paint thickness	Two-pack 821 Acid Polyurethane Lacquer Enamel, thickness $\geq 60 \mu\text{m}$				Two-pack epoxy paint, thickness $\geq 70 \mu\text{m}$			
<b>Bearings</b>	D-end 2 pole 4 to 8 pole	6310 DDU C3	6312 DDU C3	6313 ZZ C3	6314 C3	6316/C4 6316/C3	6316/C4 6319/C3	6319M/C4 6322/C3	
	N-end 2 pole 4 to 8 pole	6210 DDU C3	6212 DDU C3	6213 ZZ C3	6214 C3	6316/C4 6316/C3	6316/C4 6316/C3	6319M/C4 6319/C3	
<b>Axially-locked bearings</b>	Inner bearing cover	As standard, locked at D-end							
<b>Lubrication</b>		Greased for life or regreasable			Regreasable bearings				
<b>Rating plate</b>	Material	Stainless steel				Acid proof stainless steel			
<b>Terminal box</b>	Frame material	Cast iron HT150 GB5675-85				Cast iron GG 15/GRS 150			
	Cover material	Cast iron HT150 GB5675-85				Cast iron GG 15/GRS 150			
<b>Connections</b>	Cable entries	2xM40x1.5	2xM50x1.5	2xM50x1.5	2xM63x1.5	2xM63 + 2xM20			
	Terminals	6 terminals for connection							
<b>Fan</b>	Material	Reinforced glass fiber				Reinforced glass fiber or aluminium			
<b>Fan cover</b>	Material	Steel							
	Paint colour shade	Blue, Munsell 8B 4.5/3.25 / NCS 4822 B05G							
	Paint thickness	Two-pack 821 Acid Polyurethane Lacquer Enamel, thickness $\geq 60 \mu\text{m}$				Two-pack epoxy polyester paint, thickness $\geq 80 \mu\text{m}$			
<b>Stator winding</b>	Material	Copper							
	Insulation	Insulation class F							
	Winding protection	On request				3 PTC thermistors as standard, 150°C			
<b>Rotor winding</b>	Material	Pressure die-cast aluminium							
<b>Balancing method</b>		Half key balancing as standard							
<b>Key way</b>		Open key way							
<b>Enclosure</b>		IP 55				IP 55, higher protection on request			
<b>Cooling method</b>		IC 411							

4





# Drive<sup>IT</sup> General Purpose Open Drip Proof Motors

Totally enclosed squirrel cage three phase low  
voltage motors,  
Sizes 250 - 400, 75 to 800 kW

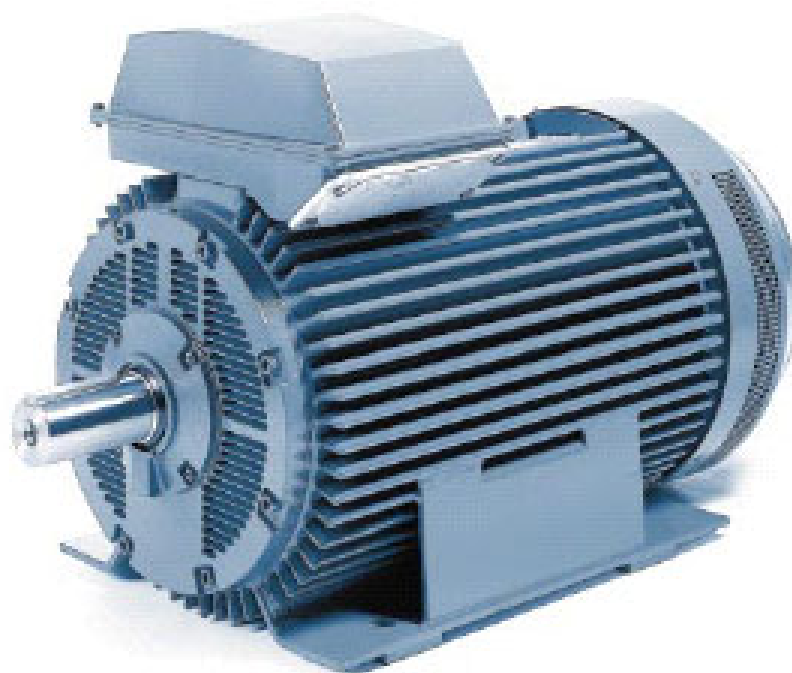

<b>Mechanical design.....</b>	<b>146</b>
<b>Ordering information.....</b>	<b>151</b>
<b>Technical data.....</b>	<b>152</b>
<b>Variant codes.....</b>	<b>157</b>
<b>Dimension drawings.....</b>	<b>158</b>
<b>Rating plates.....</b>	<b>163</b>
<b>Open drip proof motors in brief.....</b>	<b>164</b>

# Mechanical design

## Stator

The stator frame is made of profile-pressed sheet steel, giving the motor high mechanical strength, low weight and a good surface finish. The stator core is welded into the stator frame and contributes to its excellent mechanical properties.

Feet and lifting eyes are welded to the stator frame. The terminal box and end shields are of cast iron.

## Drain holes

Motors that will be operated in very humid or wet environments, and especially under intermittent duty, should be provided with drain holes. The appropriate IM designation, such as IM V3 (IM 3031), is specified, on the basis of the method of motor mounting.

M2FA motors are fitted with drain holes and plugs. The

plugs are open on delivery. Check that the drain holes and grease outlet face downwards, when mounting designation differs from standard horizontal mounting.

In the case of vertical mounting, the upper plug must be hammered home completely. In very dusty environments the drain hole plug should be knocked in.

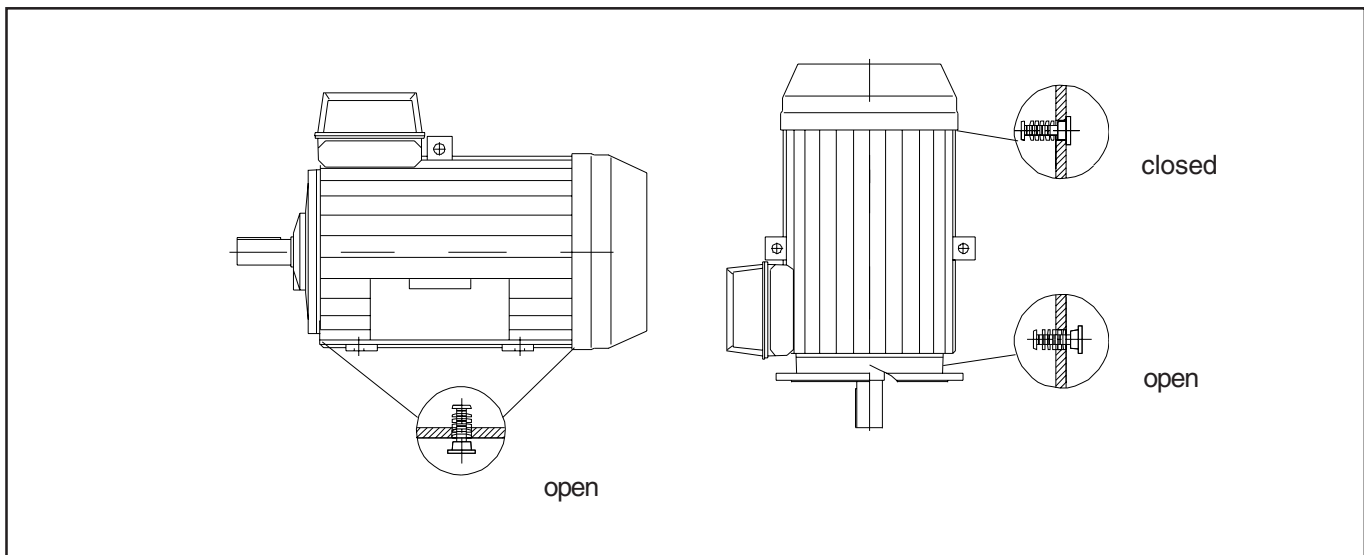

## Terminal box

Terminal boxes are mounted either on the top of the motor, or on either side of the motor, see ordering information page .

In basic version the terminal box can be rotated 2x180° to allow cable entry from either side of the motor.

The terminal box is equipped with cable glands or cable boxes as standard, and terminations are suitable for Cu- and Al-cables. Cables are connected to the terminals by cable lugs which are not included with the motor.

To enable us to supply suitable terminations for the motor please state cable type, quantity and size when ordering.

For dimension drawings of terminal boxes, see drawings.

# Co-ordination of terminal boxes and cable entries

If no ordering information on the cable is given, it is assumed to be p.v.c. -insulated type and termination parts are supplied according to the table below and on next page.

Deviations from standard design according to the following tables are available on request.

## M2FA 280 to 400 motors with top-mounted terminal box

### Standard cable entries and cable boxes

Voltage 380 - 690 V, 50 Hz

Motor size M2CA	Ter- minal box	Flange or adapter	Cable box or cable gland	Gland thread	Cable diameter	Max. connection cable area mm <sup>2</sup>	Terminal bolt size	Voltage/ freq. code
<b>3000 r/min (2 poles)</b>								
250	122/4	3GZF 294730-749	2x 3GZF 294730-613	2x M63x1.5	2x Ø32-49	2x150	M12	
280	122/4	3GZF 294730-749	2x 3GZF 294730-613		2x Ø32-49	2x150	M12	
315	142/4	3GZF 294730-753	2x 3GZF 294730-613		2x Ø32-49	2x240	M12	
355 SA	142/4	3GZF 294730-753	2x 3GZF 294730-613		2x Ø32-49	2x240	M12	
355 M_	162/4	3GZF 294730-944	3GZF 294730-301		2x Ø48-60	4x240	M12	D
	142/4	-	3GZF 294730-301		2x Ø48-60	2x240	M12	E
355 L_	162/4	3GZF 294730-944	3GZF 294730-301		2x Ø48-60	4x240	M12	
<b>1500 r/min (4 poles)</b>								
250	122/4	3GZF 294730-749	2x 3GZF 294730-613	2x M63x1.5	2x Ø32-49	2x150	M12	
280	122/4	3GZF 294730-749	2x 3GZF 294730-613		2x Ø32-49	2x150	M12	
315	142/4	3GZF 294730-753	2x 3GZF 294730-613		2x Ø32-49	2x240	M12	
355 S_	142/4	3GZF 294730-753	2x 3GZF 294730-613		2x Ø32-49	2x240	M12	
355 M_	162/4	3GZF 294730-944	3GZF 294730-301		2x Ø48-60	4x240	M12	D
	142/4	-	3GZF 294730-301		2x Ø48-60	2x240	M12	E
355 LA	162/4	3GZF 294730-944	3GZF 294730-301		2x Ø48-60	4x240	M12	
355 LKD	162/4	3GZF 294730-944	3GZF 294730-501		2x Ø60-80	4x240	M12	
400 LKA	162/9	3GZF 294730-944	3GZF 294730-501		2x Ø60-80	4x240	M12	D
	162/4	3GZF 294730-944	3GZF 294730-501		2x Ø60-80	4x240	M12	E
400 LKB	162/9	3GZF 294730-944	3GZF 294730-501		2x Ø60-80	4x240	M12	
<b>1000 r/min (6 poles)</b>								
250	122/4	3GZF 294730-749	2x 3GZF 294730-613	2x M63x1.5	2x Ø32-49	2x150	M12	
280	122/4	3GZF 294730-749	2x 3GZF 294730-613		2x Ø32-49	2x150	M12	
315	142/4	3GZF 294730-753	2x 3GZF 294730-613		2x Ø32-49	2x240	M12	
355 S_	142/4	3GZF 294730-753	2x 3GZF 294730-613		2x Ø32-49	2x240	M12	
<b>750 r/min (8 poles)</b>								
250	122/4	3GZF 294730-749	2x 3GZF 294730-613	2x M63x1.5	2x Ø32-49	2x150	M12	
280	122/4	3GZF 294730-749	2x 3GZF 294730-613		2x Ø32-49	2x150	M12	
315	142/4	3GZF 294730-753	2x 3GZF 294730-613		2x Ø32-49	2x240	M12	
355 S_	142/4	3GZF 294730-753	2x 3GZF 294730-613		2x Ø32-49	2x240	M12	

Voltage/frequency codes:

D - 380-420 VD 50 Hz, 660-690 VY 50 Hz, 440-480 VD 60 Hz

E - 500 VD 50 Hz, 575 VD 60 Hz

Examples:

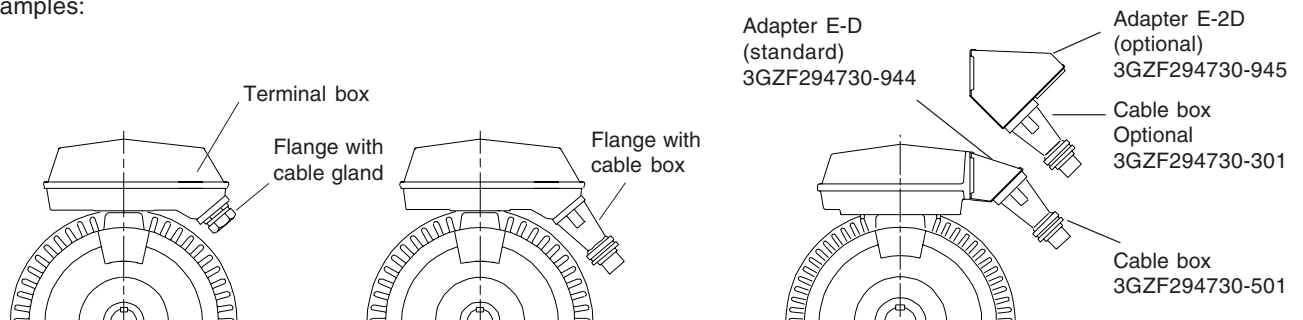

## Alternatives for cable entries and cable boxes

The tables on previous pages show the standard terminal boxes and termination parts that are delivered when no information on the cable is given.

The table below shows the different alternatives avail-

able for cable boxes and cable entries. Other types on request.

Motor size	Terminal box	Opening type	Max. rate current A (Y/D-conn.)	Max. size of conductor mm <sup>2</sup>	Cable entry mm	Cable box	Blank plate
250	122/4	C (FL21)	210/360	2x150	1xPg29...42 2xPg29...42	1xØ36...52/Ø48...60 1xØ36...52/Ø48...60	MKLN 20
280	122/4	C (FL21)	210/360	2x150	1xPg29...42 2xPg29...42	1xØ36...52/Ø48...60 1xØ36...52/Ø48...60	MKLN 20
315	142/4	D (FL33)	370/640	2x185	1xPg36...42 2xPg36...48	1xØ36...52/Ø48...60 2xØ48...60/Ø50...68	MKLN 30
355, 400	142/4	D (FL33)	370/640	2x240	1xPg36...42 2xPg36...48	1xØ36...52/Ø48...60 2xØ48...60/Ø50...68	MKLN 30
	162/4	E-D <sup>1)</sup>	550/950	4x240	1xPg36...42 2xPg36...48	1xØ36...52/Ø48...60 2xØ48...60/Ø50...68 2x2Ø68...80	
		E-2D <sup>1)</sup>	550/950	4x240	2x1Pg36...42 2x2Pg36...48	2x1xØ36...52/Ø48...60 2x2xØ48...60/Ø50...68 2x2Ø68...80	

<sup>1)</sup> Terminal box type 162/4 is used with a combination of one E-opening and one or two D-openings, as described below:

**Terminal box 162 with adapting flange 3GZF 294730-501 (E-D) or optional 3GZF 294730-301 (E-2D):**

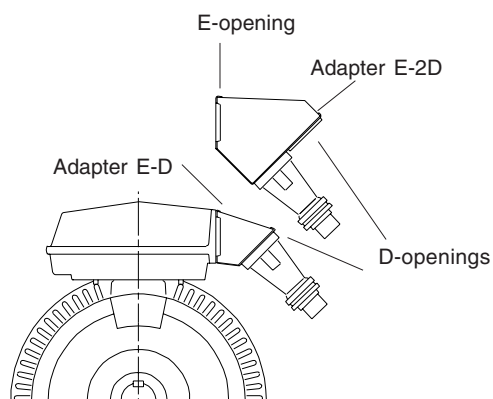

**Terminal box 162 with adapting flange:**

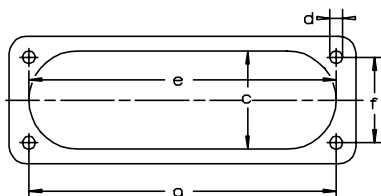
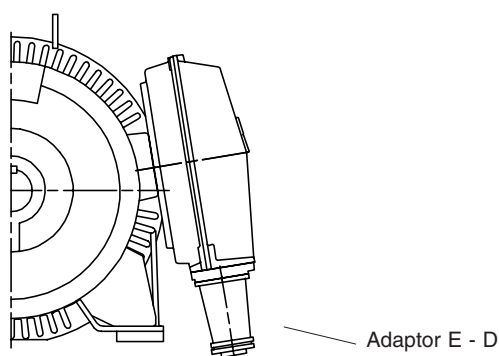

Opening	c	e	f	g	d
C (FL 21)	62	193	62	193	M8
D (FL 33)	100	300	80	292	M10
E (FL 40)	115	370	100	360	M12

# Bearings

The motors are normally fitted with single-row deep groove ball bearings as listed in the table on the right. The complete ball bearing designation is stated on the rating plate.

If the bearing at the D-end is replaced with a roller bearing (NU- or NJ-), higher radial forces can be handled. Roller bearings are suitable for belt drive applications.

When there are high axial forces, angular-contact ball bearings should be used. This option is available on request. When a motor with angular-contact ball bearings is ordered, the method of mounting and direction and magnitude of the axial force must be specified. For special bearings, please see variant codes.

## Standard bearing types

Motor size	Number of poles	Basic version with deep groove ball bearings		Version with roller bearings, variant code 037
		D-end	N-end	D-end
250	2	6316/C4	6316/C4	-
	4-8	6316/C3	6316/C3	(NU 316/C3)
280	2	6316/C4	6316/C4	-
	4-8	6319/C3	6316/C3	(NU 319/C3)
315	2	6316/C4	6316/C4	-
	4-8	6319/C3	6316/C3	(NU319/C3)
355	2 <sup>1)</sup>	-	-	-
	4-8	6322/C3	6319/C3	(NU 322/C3)
400	4	6322/C3	6319/C3	(NU 322/C3)

<sup>1)</sup> Please check technical construction with ABB.

## Bearing seals

M2FA motors have, as standard, V-rings at both ends. The size and type of suitable seals are in accordance with the table below:

Motor size	Standard design Axial seal		Alternative design Radial seal (DIN 3760)	Number of poles	d <sub>1</sub>	d <sub>2</sub>	B <sub>1</sub>	b
	D-end	N-end						
250	VS 280	VS280	80x100x10	2	80	100	13.5	10
	VS280	VS280	80x100x10	4-8	80	100	13.5	10
280	VS80	VS80	80x100x10 <sup>1)</sup>	2	80	100	13.5	10
	VS80	VS80	95x120x12	4-8	95	120	13.5	12
315	VS80	VS80	80x100x10 <sup>1)</sup>	2	80	100	13.5	10
	VS95	VS80	95x120x12	4-8	95	120	13.5	12
355	VS95	VS95	95x120x12 <sup>1)</sup>	2	95	120	13.5	12
	VS110	VS95	110x140x12 <sup>1)</sup>	4-8	110	140	15.5	12
400	VS110	VS95	110x140x12 <sup>1)</sup>	4-8	110	140	15.5	12

<sup>1)</sup> Viton-seal

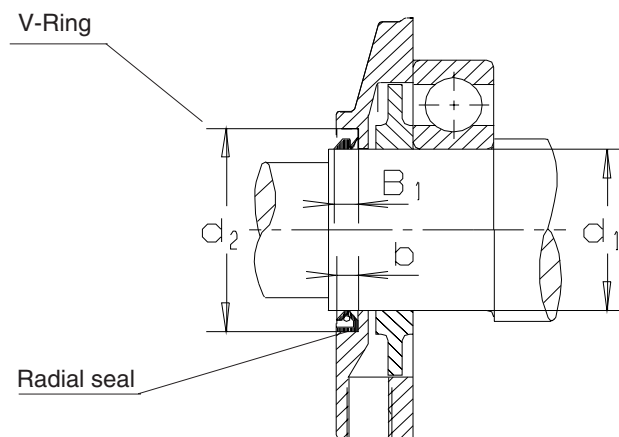

# Permissible radial forces

The table below gives the permissible radial force in Newtons, assuming zero axial force. The values are based on normal conditions at 50 Hz and calculated bearing lives of 40,000 h.

At 60 Hz the values must be reduced by 10 %. For two-speed motors, the values must be based on the higher speed. Permissible loads of simultaneous radial and axial forces will be supplied on request.

Motors are B3 version with force directed sideways. In some cases the strength of the shaft affects the permissible forces.

## Permissible radial and axial force for a bearing life of 40,000 hours

Motor size	Number of poles	Length of shaft extension E (mm)	Permissible radial force for:				Permissible axial force for <sup>1)</sup> :				
			Horizontal mounting, sideways direction of force						Horizontal mounting	Vertical mounting with shaft extension downwards	
			Ball bearing at point of application:		Roller bearing at point of application:		Direction of force				
		$X_0$ N	$X_{max}$ N	$X_0$ N	$X_{max}$ N	Outwards N	Upwards N	Downwards N			
250	2	140	5750	4700	–	–	3850	6750	2950		
	4	140	7250	5950	20000	12000	4300	7350	3300		
	6	140	8300	6800	22600	12000	5250	8500	3900		
	8	140	9150	7450	24600	12100	6100	9500	4750		
280	2	140	5850	4500	–	–	3800	7150	2250		
	4	170	8900	7050	26100	11400	5300	8800	3800		
	6	170	10200	8100	29500	11300	6500	10100	4700		
	8	170	11200	8900	32100	11100	7450	11200	5500		
315	2	140	5800	4800	–	–	3700	7450	1800		
	4	170	9000	7300	26200	14000	5000	9250	2750		
	6	170	10200	8350	29600	14200	6350	10800	3300		
	8	170	11300	9200	32300	14300	7300	12200	4300		
355	2	140	6200	5400	–	–	2100	<sup>2)</sup>	<sup>2)</sup>		
	4	210	12100	9800	36500	18100	4100	<sup>2)</sup>	<sup>2)</sup>		
	6	210	13800	11200	41500	20200	5500	<sup>2)</sup>	<sup>2)</sup>		
	8	210	15200	12300	45000	21000	6900	<sup>2)</sup>	<sup>2)</sup>		
400	2	170	<sup>2)</sup>	<sup>2)</sup>	–	–	<sup>2)</sup>	<sup>2)</sup>	<sup>2)</sup>		
	4	210	12200	10500	37500	13500	3900	<sup>2)</sup>	<sup>2)</sup>		
	6	210	<sup>2)</sup>	<sup>2)</sup>	<sup>2)</sup>	<sup>2)</sup>	<sup>2)</sup>	<sup>2)</sup>	<sup>2)</sup>		
	8	210	<sup>2)</sup>	<sup>2)</sup>	<sup>2)</sup>	<sup>2)</sup>	<sup>2)</sup>	<sup>2)</sup>	<sup>2)</sup>		

<sup>1)</sup> Flange-mounted motors with deep groove ball bearings at D-end. Other designs on request. No simultaneous radial forces allowed.

<sup>2)</sup> On request.

If the radial force is applied between points  $X_0$  and  $X_{max}$ , the permissible force  $F_R$  can be calculated from the following formula:

$$F_R = F_{x_0} - \left( \frac{F_{x_0} - F_{x_{max}}}{E} \right) \cdot X$$

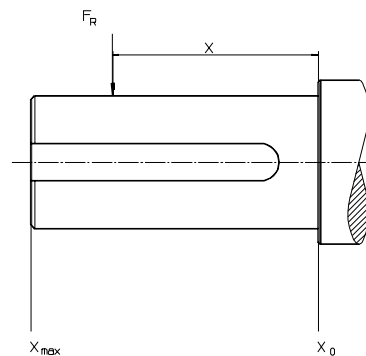

# Ordering information

## Sample order

When placing an order, please state the following minimum data in the order, as in the example.

The product code of the motor is composed in accordance with the following example.

Motor type	M2FA 315SMA
Pole number	2
Mounting arrangement (IM-code)	IM B3 (IM 1001)
Rated output	200 kW
Product code	3GFA312210-ASB
Variant codes if needed	

<b>A</b>	<b>B</b>	<b>C</b>	<b>D,E,F, G</b>	<b>A</b> Motor type
<b>M2FA 315 SMA</b>		<b>3GFA 312 210 - ADA, 003 etc.</b>		<b>B</b> Motor size
		1 - 4	5-6 7 8-10 11 12 13 14	<b>C</b> Product code
				<b>D</b> Mounting arrangement code
				<b>E</b> Voltage and frequency code
				<b>F</b> Generation code
				<b>G</b> Variant codes

### Explanation of the product code:

#### Positions 1 to 4

**3GFA** = Open drip proof squirrel cage three phase motor with steel frame

#### Positions 5 and 6

IEC-frame size

**25** = 250    **31** = 315    **40** = 400

**28** = 280    **35** = 355

#### Position 7

Speed (pole pairs)

**1** = 2 poles    **6** = 8 poles  
**2** = 4 poles    **7** => 12 poles  
**3** = 6 poles    **8** = Two-speed motors  
**4** = 8 poles    **9** = Multi-speed motors  
**5** = 10 poles

#### Position 8 to 10

Serial number

#### Position 11

-(dash)

#### Position 12

Mounting arrangement

**A** = Foot-mounted, top-mounted terminal box  
**L** = Foot-mounted, terminal box LHS, seen from D-end  
**R** = Foot-mounted, terminal box RHS, seen from D-end  
**B** = Flange-mounted  
**L** = Foot-mounted, terminal box LHS, seen from D-end  
**R** = Foot-mounted, terminal box RHS, seen from D-end  
**H** = Foot- and flange-mounted, top-mounted terminal box  
**S** = Foot- and flange-mounted, terminal box LHS seen from D-end  
**T** = Foot- and flange-mounted, terminal box RHS seen from D-end

#### Position 13

Voltage/frequency code

See tables below

#### Position 14

Generation code

**A, B, C...**

**The product code must, if needed, followed by variant codes.**

**Code letters for supplementing the product code for voltage and frequency – single speed motors:**

A	B	D	E	F	H
380 VY 50 Hz	380 VΔ 50 Hz	380-420 VΔ 50 Hz 660-690 VY 50 Hz 440-480 VΔ 60 Hz	500 VΔ 50 Hz 575 VΔ 60 Hz	500 VY 50 Hz 575 VY 60 Hz	415 VΔ 50 Hz
S	T	U	X		
220-240 VΔ 50 Hz 380-420 VY 50 Hz 440-480 VY 60 Hz	660 VΔ 50 Hz	690 VΔ 50 Hz	Other rated voltage, connection or frequency, max. 690 V		

**Code letters for supplementing the product code for voltage and frequency – two-speed motors:**

A	B	D	E	H	S
220 V 50 Hz	380 V 50 Hz	380-400 V 50 Hz 440-480 V 60 Hz	500 V 50 Hz 575 V 60 Hz	400-415 V 50 Hz 460-480 V 60 Hz	220-230 V 50 Hz

# General purpose open drip proof motors

## Technical data for totally enclosed squirrel cage three phase motors, steel frame

IP 23 S – IC 01 – Insulation class F, temperature rise class B

Output kW	Motor type	Product code	Speed r/min	Efficiency %	Power factor cos φ 100%	Current		Torque		
						I <sub>N</sub> A	I <sub>s</sub> / I <sub>N</sub>	T <sub>N</sub> Nm	T <sub>s</sub> / T <sub>N</sub>	T <sub>max</sub> / T <sub>N</sub>
<b>3000 r/min = 2 poles</b>			<b>400 V 50 Hz</b>			<b>Basic design</b>				
90	M2FA 250 SA	3GFA 251 110-••A	2962	92.6	0.84	169	6.0	290	1.5	2.2
110	M2FA 250 MA	3GFA 251 310-••A	2958	93.3	0.84	203	6.2	355	1.6	2.4
132	<sup>2)</sup> M2FA 280 SMA	3GFA 281 210-••A	2971	94.5	0.84	241	7.0	424	2.1	2.4
160	M2FA 315 SA	3GFA 311 110-••A	2977	94.2	0.86	289	6.7	513	1.6	2.5
200	M2FA 315 SMA	3GFA 311 210-••A	2975	94.4	0.86	353	7.1	643	1.8	2.6
250	M2FA 315 MB	3GFA 311 320-••A	2975	94.5	0.87	431	7.1	804	1.9	2.6
315	M2FA 315 MC	3GFA 311 330-••A	2977	94.6	0.84	573	7.8	1012	2.1	2.8
355	<sup>1)</sup> M2FA 315 LA	3GFA 311 510-••A	2969	94.9	0.89	606	6.8	1142	2.0	2.5
400	M2FA 315 LB	3GFA 311 520-••A	2969	94.8	0.88	700	7.3	1288	2.0	2.6
400	<sup>5)</sup> M2FA 355 SA	3GFA 351 110-••A	2982	94.7	0.88	680	7.1	1280	1.1	2.6
450	<sup>5)</sup> M2FA 355 MA	3GFA 351 310-••A	2978	95.0	0.89	765	7.4	1443	1.3	3.0
500	<sup>5)</sup> M2FA 355 MB	3GFA 351 320-••A	2973	95.1	0.90	851	6.7	1606	1.2	2.7
560	<sup>5)</sup> M2FA 355 LA	3GFA 351 510-••A	2981	95.5	0.89	956	8.7	1794	1.5	3.1
<b>3000 r/min = 2 poles</b>			<b>400 V 50 Hz</b>			<b>High-output design</b>				
132	M2FA 250 MB	3GFA 251 320-••A	2964	93.8	0.83	242	7.1	425	2.0	2.6
160	M2FA 280 MB	3GFA 281 320-••A	2971	94.9	0.88	279	7.0	514	2.0	2.7
<b>1500 r/min = 4 poles</b>			<b>400 V 50 Hz</b>			<b>Basic design</b>				
75	M2FA 250 SA	3GFA 252 110-••A	1473	92.6	0.82	146	5.5	486	1.8	2.2
90	<sup>1)</sup> M2FA 250 MA	3GFA 252 310-••A	1473	93.0	0.83	172	5.6	583	1.9	2.3
110	M2FA 280 SA	3GFA 282 110-••A	1476	93.1	0.83	211	5.8	713	1.8	2.4
132	M2FA 280 SMA	3GFA 282 210-••A	1477	93.8	0.84	245	5.9	853	1.8	2.3
160	M2FA 315 SA	3GFA 312 110-••A	1483	94.6	0.83	297	6.5	1030	1.8	2.5
200	M2FA 315 SMA	3GFA 312 210-••A	1482	94.7	0.83	366	6.5	1287	1.8	2.3
250	M2FA 315 MB	3GFA 312 320-••A	1481	94.9	0.83	452	6.7	1611	1.7	2.3
315	<sup>1)</sup> M2FA 315 LA	3GFA 312 510-••A	1477	94.5	0.83	577	6.7	2036	2.2	2.5
315	M2FA 355 SA	3GFA 352 110-••A	1484	95.0	0.85	555	6.4	2027	1.7	2.4
355	<sup>2)</sup> M2FA 355 SB	3GFA 352 120-••A	1485	95.4	0.82	653	6.6	2282	1.9	2.5
400	<sup>2)</sup> M2FA 355 SC	3GFA 352 130-••A	1484	95.3	0.82	733	5.9	2574	1.7	2.2
450	<sup>2)</sup> M2FA 355 MA	3GFA 352 310-••A	1485	95.4	0.83	810	6.5	2896	1.8	2.4
500	<sup>1)2)</sup> M2FA 355 LA	3GFA 352 510-••A	1486	95.4	0.81	920	7.7	3213	2.0	2.8
600	M2FA 355 LKD	3GFA 352 540-••A	<sup>4)</sup>							
710	M2FA 400 LKA	3GFA 402 510-••A	<sup>4)</sup>							
800	M2FA 400 LKB	3GFA 402 520-••A	<sup>4)</sup>							
<b>1500 r/min = 4 poles</b>			<b>400 V 50 Hz</b>			<b>High-output design</b>				
110	<sup>1)</sup> M2FA 250 MB	3GFA 252 320-••A	1471	92.8	0.83	211	5.5	714	1.8	2.3
160	M2FA 280 MB	3GFA 282 320-••A	1480	94.0	0.81	305	7.2	1032	2.5	2.6

The two bullets in the product code indicate choice of mounting arrangement, voltage and frequency (see ordering information page).

<sup>1)</sup> Temperature rise class F.

<sup>2)</sup> Special winding for 415V 50 Hz.

<sup>3)</sup> 415 V 50 Hz and 440 V 60 Hz on request.

<sup>4)</sup> On request.

<sup>5)</sup> Please check technical construction with ABB.



# General purpose open drip proof motors

## Technical data for totally enclosed squirrel cage three phase motors, steel frame

IP 23 S – IC 01 – Insulation class F, temperature rise class B

Output kW	Motor type	Speed r/min	Efficiency %	Power factor cos φ	Current I <sub>N</sub> A	Speed r/min	Efficiency %	Power factor cos φ	Current I <sub>N</sub> A	Moment of inertia J = ¼ GD <sup>2</sup> kgm <sup>2</sup>	Weight kg	Sound pressure level L <sub>p</sub> dB(A)
<b>3000 r/min = 2 poles</b>		<b>380 V 50 Hz</b>				<b>415 V 50 Hz</b>				<b>Basic design</b>		
90	M2FA 250 SA	2955	92.6	0.86	172	2966	92.7	0.81	166	0.4	360	87
110	M2FA 250 MA	2958	93.2	0.86	208	2967	93.3	0.81	200	0.47	395	87
132	<sup>2)</sup> M2FA 280 SMA	2969	94.4	0.86	246	2966	94.1	0.87	227	0.8	540	87
160	M2FA 315 SA	2975	94.2	0.87	302	2978	94.2	0.84	282	1.2	695	92
200	M2FA 315 SMA	2974	94.3	0.87	370	2978	94.4	0.84	344	1.4	770	92
250	M2FA 315 MB	2974	94.4	0.88	449	2976	94.5	0.85	420	1.7	840	92
315	M2FA 315 MC	2974	94.6	0.86	576	2971	94.6	0.88	530	1.7	840	92
355	<sup>1)</sup> M2FA 315 LA	2965	94.8	0.89	635	2970	94.9	0.86	591	2.1	975	92
400	M2FA 315 LB	2966	94.7	0.88	720	2970	94.8	0.85	683	2.1	975	92
400	<sup>5)</sup> M2FA 355 SA	2980	94.6	0.90	700	2983	94.7	0.87	663	3.2	1220	93
450	<sup>5)</sup> M2FA 355 MA	2975	94.9	0.90	795	2979	95.0	0.87	746	3.5	1320	93
500	<sup>5)</sup> M2FA 355 MB	2970	95.1	0.90	880	2974	95.1	0.87	830	3.5	1320	93
560	<sup>5)</sup> M2FA 355 LA	2978	95.5	0.90	980					4.8	1530	93
<b>3000 r/min = 2 poles</b>		<b>380 V 50 Hz</b>				<b>415 V 50 Hz</b>				<b>High-output design</b>		
132	M2FA 250 MB	2961	93.8	0.86	247	2960	93.7	0.87	225	0.56	430	88
160	M2FA 280 MB	2968	94.8	0.88	288	2973	94.9	0.86	269	1.15	580	89
<b>1500 r/min = 4 poles</b>		<b>380 V 50 Hz</b>				<b>415 V 50 Hz</b>				<b>Basic design</b>		
75	M2FA 250 SA	1469	92.9	0.84	152	1474	92.6	0.81	142	0.6	370	80
90	<sup>1)</sup> M2FA 250 MA	1470	93.2	0.85	178	1474	93.0	0.82	168	0.72	385	76
110	M2FA 280 SA	1474	92.8	0.85	217	1477	93.1	0.82	206	1.15	445	81
132	M2FA 280 SMA	1474	93.2	0.86	255	1478	93.8	0.83	239	1.4	490	81
160	M2FA 315 SA	1481	94.5	0.85	306	1481	94.6	0.84	283	2	680	86
200	M2FA 315 SMA	1480	94.6	0.85	379	1483	94.8	0.82	360	2.3	735	86
250	M2FA 315 MB	1479	94.7	0.86	470	1482	94.9	0.83	441	2.9	850	86
315	<sup>1)</sup> M2FA 315 LA	1475	94.5	0.85	596	1473	93.5	0.86	540	3.5	970	87
315	M2FA 355 SA	1482	94.8	0.86	584	1485	95.0	0.83	541	5.5	1220	89
355	<sup>2)</sup> M2FA 355 SB	1484	95.3	0.84	670	1485	95.4	0.83	622	5.5	1220	89
400	<sup>2)</sup> M2FA 355 SC	1482	95.2	0.85	746	1483	95.1	0.84	685	5.5	1220	89
450	<sup>2)</sup> M2FA 355 MA	1483	95.3	0.85	835	1484	95.4	0.83	798	6.5	1350	89
500	<sup>1)2)</sup> M2FA 355 LA	1484	95.3	0.84	949	1486	95.4	0.83	880	7.8	1550	89
600	M2FA 355 LKD										9.8	1820
710	M2FA 400 LKA										2700	
800	M2FA 400 LKB										2700	
<b>1500 r/min = 4 poles</b>		<b>380 V 50 Hz</b>				<b>415 V 50 Hz</b>				<b>High-output design</b>		
110	<sup>1)</sup> M2FA 250 MB	1468	92.5	0.85	215	1472	92.8	0.82	206	0.91	430	81
160	M2FA 280 MB	1478	93.9	0.84	310	1481	94.0	0.81	298	1.7	550	87

The two bullets in the product code indicate choice of mounting arrangement, voltage and frequency (see ordering information page).

<sup>1)</sup> Temperature rise class F.

<sup>2)</sup> Special winding for 415V 50 Hz.

<sup>3)</sup> 415 V 50 Hz and 440 V 60 Hz on request.

<sup>4)</sup> On request.

<sup>5)</sup> Please check technical construction with ABB.

# General purpose open drip proof motors

## Technical data for totally enclosed squirrel cage three phase motors, steel frame

IP 23 S – IC 01 – Insulation class F, temperature rise class B

Output kW	Motor type	Product code	Speed r/min	Efficiency %	Power factor cos φ 100%	Current		Torque		
						I <sub>N</sub> A	I <sub>s</sub> I <sub>N</sub>	T <sub>N</sub> Nm	T <sub>s</sub> T <sub>N</sub>	T <sub>max</sub> T <sub>N</sub>
<b>1000 r/min = 6 poles</b>			<b>400 V 50 Hz</b>			<b>Basic design</b>				
45	M2FA 250 SA	3GFA 253 110-••A	985	91.0	0.80	94	7.0	436	1.7	2.4
55	M2FA 250 MA	3GFA 253 310-••A	984	91.4	0.82	110	6.8	533	1.7	2.4
75	M2FA 280 SA	3GFA 283 110-••A	987	92.8	0.76	155	5.8	725	1.9	2.2
90 <sup>1)</sup>	M2FA 280 SMA	3GFA 283 210-••A	987	93.1	0.76	187	6.1	870	2.0	2.3
110	M2FA 315 SA	3GFA 313 110-••A	988	93.5	0.81	210	7.4	1062	1.7	2.6
132	M2FA 315 SMA	3GFA 313 210-••A	988	94.0	0.83	248	7.6	1275	1.8	2.7
160	M2FA 315 MB	3GFA 313 320-••A	988	94.1	0.82	300	8.2	1545	1.9	2.8
185 <sup>1)</sup>	M2FA 315 LA	3GFA 313 510-••A	987	94.4	0.83	346	8.5	1788	1.9	2.9
200	M2FA 355 SA	3GFA 353 110-••A	990	94.7	0.82	373	7.1	1927	1.6	2.5
250	M2FA 355 SB	3GFA 353 120-••A	990	94.8	0.83	457	7.3	2409	1.6	2.5
300	M2FA 355 MA	3GFA 353 310-••A	990	95.1	0.81	541	7.2	2894	1.7	2.4
<b>1000 r/min = 6 poles</b>			<b>400 V 50 Hz</b>			<b>High-output design</b>				
75 <sup>1)</sup>	M2FA 250 MB	3GFA 253 320-••A	984	92.0	0.81	150	6.8	727	1.8	2.5
110 <sup>1)</sup>	M2FA 280 MB	3GFA 283 320-••A	987	93.6	0.76	227	6.5	1063	2.1	2.3
<b>750 r/min = 8 poles</b>			<b>400 V 50 Hz</b>			<b>Basic design</b>				
37	M2FA 250 SB	3GFA 254 120-••A	734	88.9	0.79	78	5.3	481	1.3	2.3
45 <sup>1)</sup>	M2FA 250 MB	3GFA 254 320-••A	733	89.7	0.78	96	5.5	588	1.4	2.4
55	M2FA 280 SA	3GFA 284 110-••A	738	91.2	0.78	117	5.6	711	1.2	2.0
75 <sup>1)</sup>	M2FA 280 SMA	3GFA 284 210-••A	738	91.8	0.76	161	6.1	970	1.4	2.1
90	M2FA 315 SMA	3GFA 314 210-••A	739	92.9	0.79	183	6.8	1162	1.7	2.5
110	M2FA 315 MB	3GFA 314 320-••A	739	93.4	0.78	224	7.3	1420	1.8	2.6
132 <sup>1)</sup>	M2FA 315 LA	3GFA 314 510-••A	739	93.3	0.78	268	7.2	1706	1.8	2.6
150	M2FA 355 SA	3GFA 354 110-••A	740	93.4	0.75	318	5.3	1934	1.3	2.0
185 <sup>1)</sup>	M2FA 355 SB	3GFA 354 120-••A	740	93.9	0.76	381	5.6	2385	1.4	2.0
<b>750 r/min = 8 poles</b>			<b>400 V 50 Hz</b>			<b>High-output design</b>				
90 <sup>1)</sup>	M2FA 280 MB	3GFA 284 320-••A	739	92.6	0.75	192	6.7	1162	1.6	2.2

The two bullets in the product code indicate choice of mounting arrangement, voltage and frequency (see ordering information page).

<sup>1)</sup> Temperature rise class F.

<sup>2)</sup> On request.

# General purpose open drip proof motors

## Technical data for totally enclosed squirrel cage three phase motors, steel frame

IP 23 S – IC 01 – Insulation class F, temperature rise class B

Output kW	Motor type	Speed r/min	Efficiency %	Power factor cos φ	Current I <sub>N</sub> A	Speed r/min	Efficiency %	Power factor cos φ	Current I <sub>N</sub> A	Moment of inertia J = ¼ GD <sup>2</sup> kgm <sup>2</sup>	Weight kg	Sound pressure level L <sub>p</sub> dB(A)
<b>1000 r/min = 6 poles</b>		<b>380 V 50 Hz</b>				<b>415 V 50 Hz</b>				<b>Basic design</b>		
45	M2FA 250 SA	983	90.8	0.83	95	983	91.0	0.8	92	1	370	<sup>2)</sup>
55	M2FA 250 MA	983	91.3	0.85	112	983	91.4	0.82	107	1.2	385	<sup>2)</sup>
75	M2FA 280 SA	985	92.7	0.79	158	986	92.7	0.79	146	1.65	440	<sup>2)</sup>
90	<sup>1)</sup> M2FA 280 SMA	986	92.9	0.79	190	987	93.1	0.78	178	2.6	475	<sup>2)</sup>
110	M2FA 315 SA	986	93.4	0.85	212	989	93.5	0.78	209	2.9	630	<sup>2)</sup>
132	M2FA 315 SMA	986	93.7	0.85	256	989	94.0	0.81	242	3.8	720	<sup>2)</sup>
160	M2FA 315 MB	986	94.0	0.85	310	989	94.1	0.8	300	4.5	810	<sup>2)</sup>
185	<sup>1)</sup> M2FA 315 LA	986	94.2	0.85	352	988	94.4	0.79	340	5.4	915	<sup>2)</sup>
200	M2FA 355 SA	989	94.5	0.84	385	990	94.7	0.81	364	8.7	1220	<sup>2)</sup>
250	M2FA 355 SB	989	94.7	0.84	478	991	94.8	0.81	446	10.2	1320	<sup>2)</sup>
300	M2FA 355 MA	988	94.9	0.85	546	991	95.1	0.82	528	12.5	1550	<sup>2)</sup>
<b>1000 r/min = 6 poles</b>		<b>380 V 50 Hz</b>				<b>415 V 50 Hz</b>				<b>High-output design</b>		
75	<sup>1)</sup> M2FA 250 MB	983	91.9	0.84	150	983	92.0	0.81	146	1.5	430	<sup>2)</sup>
110	<sup>1)</sup> M2FA 280 MB	986	93.4	0.79	231	988	93.6	0.77	219	2.9	545	<sup>2)</sup>
<b>750 r/min = 8 poles</b>		<b>380 V 50 Hz</b>				<b>415 V 50 Hz</b>				<b>Basic design</b>		
37	M2FA 250 SB	732	88.5	0.81	80	735	88.9	0.77	76	1.2	385	<sup>2)</sup>
45	<sup>1)</sup> M2FA 250 MB	731	89.3	0.80	98	734	89.7	0.76	94	1.5	430	<sup>2)</sup>
55	M2FA 280 SA	736	89.9	0.81	119	739	91.2	0.77	114	1.85	460	<sup>2)</sup>
75	<sup>1)</sup> M2FA 280 SMA	736	91.7	0.79	161	739	91.8	0.75	157	2.2	500	<sup>2)</sup>
90	M2FA 315 SMA	738	92.7	0.80	186	740	92.9	0.76	179	3.8	720	<sup>2)</sup>
110	M2FA 315 MB	738	93.2	0.80	233	740	93.4	0.76	219	4.5	810	<sup>2)</sup>
132	<sup>1)</sup> M2FA 315 LA	737	93.1	0.80	275	740	93.3	0.76	262	5.4	915	<sup>2)</sup>
150	M2FA 355 SA	739	93.3	0.77	322	741	93.4	0.73	311	8.7	1220	<sup>2)</sup>
185	<sup>1)</sup> M2FA 355 SB	739	93.7	0.78	393	741	93.9	0.74	372	10.2	1320	<sup>2)</sup>
<b>750 r/min = 8 poles</b>		<b>380 V 50 Hz</b>				<b>415 V 50 Hz</b>				<b>High-output design</b>		
90	<sup>1)</sup> M2FA 280 MB	738	92.5	0.78	192	740	92.6	0.74	188	2.9	575	<sup>2)</sup>

The two bullets in the product code indicate choice of mounting arrangement, voltage and frequency (see ordering information page).

<sup>1)</sup> Temperature rise class F.

<sup>2)</sup> On request.

# General purpose open drip proof motors

## Technical data for totally enclosed squirrel cage three phase motors, steel frame, two speed

### IP 23 S – IC 01 – Insulation class F, temperature rise class F

Output kW	Motor type	Product code	Speed r/min	Efficiency %	Power factor cos φ	Current I <sub>N</sub> A	I <sub>s</sub> I <sub>N</sub>	Torque T <sub>N</sub> Nm	T <sub>s</sub> T <sub>N</sub>	T <sub>max</sub> T <sub>N</sub>	Moment of inertia J = ¼ GD <sup>2</sup> kgm <sup>2</sup>	Weight kg	
<b>1500/1000 r/min = 4/6-poles</b>						<b>Fan drive, two separate windings</b>							
55/16	M2FA	250 SA	3GFA 258 114-•	1476/987	90.5/82.7	0.83/0.74	111/40	6.0/6.8	356/155	1.5/2.4	2.4/2.7	0.6	370
63/18.5	M2FA	250 MA	3GFA 258 314-•	1478/989	91.2/85.1	0.84/0.70	119/43	6.5/7.8	407/179	1.6/2.8	2.5/3.2	0.72	385
75/25	M2FA	250 MB	3GFA 258 324-•	1477/984	90.6/84.9	0.85/0.78	140/53	6.2/6.5	485/243	1.6/2.3	2.4/2.4	0.91	430
90/30	M2FA	280 SMA	3GFA 288 214-•	1480/987	91.0/86.3	0.85/0.76	168/65	6.7/7.2	581/290	1.7/2.6	2.7/2.4	1.4	490
110/32	M2FA	280 MB	3GFA 288 324-•	1482/988	92.3/87.4	0.84/0.77	204/69	7.4/7.3	709/309	2.1/2.7	2.8/2.7	1.7	550
132/40	M2FA	315 SMA	3GFA 318 214-•	1484/989	92.6/89.2	0.85/0.79	239/84	6.3/6.4	849/386	1.5/2.1	2.4/2.4	2.3	735
170/50	M2FA	315 MB	3GFA 318 324-•	1486/988	93.4/89.7	0.83/0.78	310/103	7.3/6.3	1092/483	1.8/2.3	2.8/2.3	2.9	850
200/63	M2FA	315 LA	3GFA 318 514-•	1486/989	93.9/90.8	0.83/0.76	362/130	7.7/7.4	1285/608	2.0/2.8	2.9/2.7	3.5	970
260/85	M2FA	355 SA	3GFA 358 114-•	1487/990	94.5/91.8	0.83/0.78	473/171	6.3/7.0	1670/820	1.4/2.3	2.4/2.4	5.5	1220
340/100	M2FA	355 MA	3GFA 358 314-•	1488/989	95.0/92.0	0.82/0.79	620/199	7.0/6.5	2182/966	1.5/2.1	2.7/2.3	6.5	1320
400/120	M2FA	355 LA	3GFA 358 514-•	1487/992	94.9/92.1	0.88/0.78	680/240	7.0/8.8	2569/1155	1.3/2.3	2.4/3.0	7.8	1550
<b>1500/750 r/min = 4 - 8 - poles</b>						<b>Fan drive, Dahlander-connection</b>							
55/14	M2FA	250 SA	3GFA 258 119-•	1477/734	90.2/83.6	0.82/0.65	108/37	5.9/4.1	356/182	1.4/1.4	2.3/1.9	0.6	370
67/17	M2FA	250 MA	3GFA 258 319-•	1478/734	90.9/85.0	0.82/0.66	129/45	6.3/4.1	433/221	1.5/1.5	2.3/1.9	0.72	385
88/22	M2FA	250 MB	3GFA 258 329-•	1478/734	91.5/86.4	0.83/0.66	167/55	6.7/4.2	569/286	1.7/1.5	2.5/1.9	0.91	430
100/25	M2FA	280 SMA	3GFA 288 219-•	1478/735	92.0/87.6	0.85/0.68	185/62	6.2/4.1	646/325	1.5/1.5	2.4/1.7	1.4	490
110/28	M2FA	280 MB	3GFA 288 329-•	1479/735	92.4/88.3	0.86/0.68	199/67	6.7/4.1	710/364	1.7/1.5	2.4/1.7	1.7	550
140/35	M2FA	315 SMA	3GFA 318 219-•	1485/740	93.5/89.9	0.83/0.64	259/87	6.8/4.7	900/452	1.5/1.6	2.6/1.9	2.3	735
185/46	M2FA	315 MB	3GFA 318 329-•	1483/738	93.7/90.5	0.85/0.67	333/110	6.5/4.2	1191/595	1.5/1.4	2.4/1.7	2.9	850
220/55	M2FA	315 LA	3GFA 318 519-•	1485/739	94.2/91.2	0.83/0.64	397/136	7.6/4.6	1415/711	1.7/1.5	2.8/2.0	3.5	975
250/63	M2FA	355 MA	3GFA 358 319-•	1486/740	94.7/92.2	0.86/0.66	440/148	6.3/4.0	1607/813	1.1/1.0	2.3/1.7	6.5	1320
315/80	M2FA	355 LA	3GFA 358 519-•	1489/741	95.1/93.0	0.84/0.64	560/195	8.0/5.0	2020/1031	1.7/1.4	2.9/2.0	7.8	1550
<b>1500/1000 r/min = 4/6-poles</b>						<b>Constant torque, two separate windings</b>							
45/30	M2FA	250 SA	3GFA 259 114-•	1480/984	89.2/86.3	0.81/0.71	89/71	6.8/6.2	290/291	1.7/2.4	2.6/2.5	0.6	370
50/32	M2FA	250 MA	3GFA 259 314-•	1479/984	89.9/87.9	0.84/0.73	96/72	6.3/6.4	323/311	1.5/2.5	2.4/2.5	0.72	385
65/43	M2FA	250 MB	3GFA 259 324-•	1480/983	89.8/88.2	0.84/0.76	125/92	6.6/6.5	419/418	1.7/2.5	2.5/2.4	0.91	430
75/50	M2FA	280 SMA	3GFA 289 214-•	1480/984	89.6/87.9	0.86/0.77	140/105	6.2/6.3	484/485	1.5/2.4	2.3/2.4	1.4	490
90/60	M2FA	280 MB	3GFA 289 324-•	1481/987	91.0/89.3	0.86/0.73	169/131	6.8/6.9	580/581	1.7/2.7	2.5/2.6	1.7	550
120/80	M2FA	315 SMA	3GFA 319 214-•	1486/988	91.8/91.2	0.85/0.75	225/171	6.3/6.2	771/773	1.5/2.3	2.5/2.3	2.3	735
150/100	M2FA	315 MB	3GFA 319 324-•	1488/989	92.6/91.8	0.82/0.75	285/215	7.6/6.6	986/966	1.8/2.5	2.9/2.5	2.9	850
185/125	M2FA	315 LA	3GFA 319 514-•	1486/988	93.4/92.2	0.83/0.73	345/265	7.8/6.8	1189/1208	1.9/2.8	2.9/2.5	3.5	970
200/130	M2FA	355 SA	3GFA 359 114-•	1487/991	93.5/92.9	0.88/0.83	360/248	7.8/9.0	1284/1253	1.2/2.3	3.0/3.2	8.5	1220
240/160	M2FA	355 MA	3GFA 359 314-•	1489/991	94.1/93.4	0.84/0.84	439/289	8.6/8.8	1539/1542	1.6/2.4	3.4/2.8	10.2	1320
	M2FA	355 LA	3GFA 359 514-•										
<b>1500/750 r/min = 4 - 8 - poles</b>						<b>Constant torque, Dahlander-connection</b>							
48/26	M2FA	250 SA	3GFA 259 119-•	1477/740	88.7/86.8	0.86/0.63	92/68	5.9/5.7	310/336	1.7/2.8	2.3/2.4	1.0	370
58/34	M2FA	250 MA	3GFA 259 319-•	1478/739	89.2/87.6	0.86/0.66	109/86	6.2/5.8	375/439	1.8/2.9	2.4/2.3	1.2	385
69/38	M2FA	250 MB	3GFA 259 329-•	1480/740	89.8/88.5	0.87/0.65	126/94	6.5/6.1	445/490	2.0/3.0	2.5/2.0	1.5	430
85/48	M2FA	280 SMA	3GFA 289 219-•	1480/740	91.2/89.9	0.84/0.65	159/119	5.5/5.4	548/619	1.5/2.7	2.2/2.3	2.6	475
100/55	M2FA	280 MB	3GFA 289 329-•	1479/740	91.2/90.6	0.87/0.70	183/125	5.4/5.5	646/710	1.6/2.5	2.1/2.2	2.9	545
125/80	M2FA	315 SMA	3GFA 319 219-•	1481/739	92.0/91.6	0.88/0.75	220/164	6.0/5.8	806/1034	1.3/1.8	2.1/2.0	4.1	755
150/95	M2FA	315 MB	3GFA 319 329-•	1481/739	92.4/91.9	0.88/0.75	262/194	6.1/5.7	967/1228	1.4/1.8	2.1/2.0	4.9	845
185/120	M2FA	315 LA	3GFA 319 519-•	1482/739	92.8/92.2	0.88/0.75	325/247	6.5/5.9	1192/1551	1.5/1.9	2.2/2.0	5.8	950
225/125	M2FA	355 MA	3GFA 359 319-•	1486/743	93.6/91.8	0.91/0.73	386/271	6.7/6.2	1446/1607	1.1/1.6	2.4/2.5	10.2	1320
300/160	M2FA	355 LA	3GFA 359 519-•	1489/744	94.0/92.5	0.88/0.68	512/368	8.1/7.1	1924/2054	1.5/2.0	2.8/2.9	12.5	1550

The two bullets in the product code indicate choice of mounting arrangement, voltage and frequency (see ordering information page).

Data for other number of poles and bigger frame sizes on request.

# General purpose open drip proof motors - Variant codes

Code <sup>1)</sup>	Variant	Motor size				
		250	280	315	355	400
<b>Balancing</b>						
052	Balancing to grade R (IEC 60034-14).	P	P	P	P	P
417	Balancing to grade S (IEC 60034-14).	P	P	P	P	P
<b>Bearings and lubrication</b>						
036	Transport lock for bearings.	M	M	M	M	M
037	Roller bearing at D-end.	M	M	M	M	R
043	SPM nipples.	M	M	M	M	M
058	Angular contact bearing at D-end, shaft force away from bearing.	P	P	P	P	P
107	Bearing mounted PT100 resistance elements.	P	P	P	P	P
420	Bearing mounted PTC thermistors.	P	P	P	P	P
<b>Branch standard designs</b>						
209	Non-standard voltage or frequency (special winding).	P	P	P	P	P
<b>Coupling</b>						
035	Assembly of customer supplied coupling-half (finish bored and balanced).	M	M	M	M	M
<b>Drain holes</b>						
066	Modified drain hole position (for specified IM xxxx).	M	M	M	M	M
<b>Heating elements</b>						
450	Heating element, 100-120 V.	P	P	P	P	P
451	Heating element, 200-240 V.	M	M	M	M	M
<b>Insulation system</b>						
014	Winding insulation class H.	P	P	P	P	P
<b>Mounting arrangements</b>						
009	IM 2001 foot/flange mounted, IEC flange, from IM 1001 (B35 from B3).	P	P	P	P	R
<b>Painting</b>						
114	Special paint colour, standard grade.	M	M	M	M	M
<b>Protection</b>						
072	Radial seal at D-end.	M	M	M	M	M
005	Protective roof, vertical motor, shaft down.	M	M	M	M	M
<b>Rating &amp; instruction plates</b>						
002	Restamping voltage, frequency and output, continuous duty.	M	M	M	M	M
013	Restamping to output for class F temperature rise. Applies to variants with temperature rise to class B as standard.	M	M	M	M	M
095	Restamping output (maintained voltage, frequency), intermittent duty.	M	M	M	M	M
138	Mounting of additional identification plate, aluminium.	M	M	M	M	M
150	Instruction plates and maintenance instructions in non-standard language.	R	R	R	R	R
161	Additional rating plate delivered loose.	M	M	M	M	M

<sup>1)</sup> Certain variant codes cannot be used together.

M = On modification of a stocked motor, or on new manufacture, the number per order may be limited.

R = On request

S = Included as standard

P = New manufacture only

Code <sup>1)</sup>	Variant	M2FA, motor size				
		250	280	315	355	400
<b>Shaft &amp; rotor</b>						
069	Two shaft extensions as per basic catalogue. Standard shaft material.	P	P	P	P	P
070	One or two special shaft extensions, standard shaft material.	P	P	P	P	P
<b>Stator winding temperature sensors</b>						
121	Bimetal detectors, break type (NCC), (3 in series), 130°C, in stator winding.	M	M	M	M	M
122	Bimetal detectors, break type (NCC), (3 in series), 150°C, in stator winding.	M	M	M	M	M
123	Bimetal detectors, break type (NCC), (3 in series), 170°C, in stator winding.	M	M	M	M	M
125	Bimetal detectors, break type (NCC), (2x3 in series), 150°C, in stator winding.	M	M	M	M	M
127	Bimetal detectors, break type (NCC), (3 in series, 130°C & 3 in series, 150°C), in stator winding.	M	M	M	M	M
435	PTC - thermistors (3 in series), 130°C, in stator winding.	M	M	M	M	M
436	PTC - thermistors (3 in series), 150°C, in stator winding.	S	S	S	S	S
437	PTC - thermistors (3 in series), 170°C, in stator winding.	M	M	M	M	M
439	PTC - thermistors (2x3 in series), 150°C, in stator winding.	M	M	M	M	M
441	PTC - thermistors (3 in series 130°C & 3 in series 150°C), in stator winding.	M	M	M	M	M
442	PTC - thermistors (3 in series 150°C & 3 in series 170°C), in stator winding.	M	M	M	M	M
445	PT100 resistance element (1 per phase) in stator winding.	P	P	P	P	P
446	PT100 resistance elements (2 per phase) in stator winding.	P	P	P	P	P
<b>Terminal box</b>						
015	Motor supplied in D connection.	P	P	P	P	P
017	Motor supplied in Y connection.	M	M	M	M	M
022	Cable entry LHS (seen from D-end).	P	P	P	P	P
<b>Testing</b>						
145	Type test report from test of identical motor.	M	M	M	M	M
146	Type test with report for motor from specific delivery batch.	P	P	P	P	P
147	Type test with report for motor from specific delivery batch, customer witnessed.	P	P	P	P	P
148	Routine test report.	M	M	M	M	M
149	Testing according to separate test specification.	R	R	R	R	R
153	Reduced test for classification society.	P	P	P	P	P
760	Vibration level test.	P	P	P	P	P
761	Vibration spectrum test.	P	P	P	P	P
762	Noise level test.	P	P	P	P	P
763	Noise spectrum test.	P	P	P	P	P

<sup>1)</sup> Certain variant codes cannot be used together.

M = On modification of a stocked motor, or on new manufacture, the number per order may be limited.

R = On request

S = Included as standard

P = New manufacture only

# General purpose open drip proof motors

# Sizes 250 - 315

## Dimension drawings

Foot-mounted; IM B3 (IM 1001), IM B6 (IM 1051), IM B8 (IM 1071), IM V5 (IM 1011)  
Terminal box top-mounted

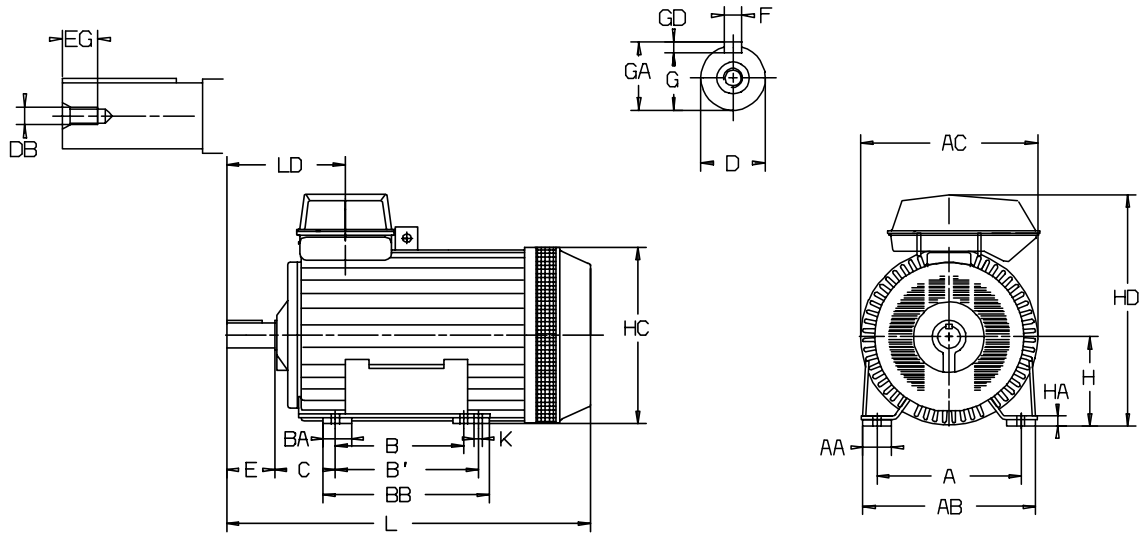

Motor size	Poles	A	AA	AB	AC	B	B'	BA	BB	C	D	DB	E	EG
250 SA	2	406	80	470	497	311	—	100	368	168	65	M20	140	40
250 SA,SB	4-8	406	80	470	497	311	—	100	368	168	75	M20	140	40
250 MA	2	406	80	470	497	349	—	100	406	168	65	M20	140	40
250 MA	4-6	406	80	470	497	349	—	100	406	168	75	M20	140	40
250 MB	4-8	406	80	470	497	349	—	100	406	168	75	M20	140	40
280 SA	4-8	457	80	545	555	368	—	100	450	190	80	M20	170	40
280 SMA	2	457	80	545	555	368	419	100	501	190	65	M20	140	40
280 SMA	4-8	457	80	545	555	368	419	100	501	190	80	M20	170	40
280 MB	2	457	80	545	555	419	—	100	501	190	65	M20	140	40
280 MB	4-8	457	80	545	555	419	—	100	501	190	80	M20	170	40
315 SA	2	508	100	622	624	406	—	100	535	216	70	M20	140	40
315 SA	4-6	508	100	622	624	406	—	100	535	216	90	M24	170	48
315 SMA	2	508	100	622	624	406	457	100	540	216	70	M20	140	40
315 SMA	4-8	508	100	622	624	406	457	100	540	216	90	M24	170	48
315 MB, MC	2	508	100	622	624	457	—	100	540	216	70	M20	140	40
315 MB	4-8	508	100	622	624	457	—	100	540	216	90	M24	170	48
315 LA, LB	2	508	100	622	624	508	—	100	592	216	70	M20	140	40
315 LA, LB	4-8	508	100	622	624	508	—	100	592	216	90	M24	170	48

Motor size	Poles	F	G	GA	GD	H	HA	HC	HD	K	L	LD
250 SA	2	18	58	69	11	250	32	496	672	24	953	381
250 SA,SB	4-8	20	67.5	79.5	12	250	32	496	672	24	953	381
250 MA	2	18	58	69	11	250	32	496	672	24	953	381
250 MA	4-6	20	67.5	79.5	12	250	32	496	672	24	953	381
250 MB	4-8	20	67.5	79.5	12	250	32	496	672	24	1023	381
280 SA	4-8	22	71	85	14	280	32	556	730	24	1020	415
280 SMA	2	18	58	69	11	280	32	556	730	24	1060	385
280 SMA	4-8	22	71	85	14	280	32	556	730	24	1090	415
280 MB	2	18	58	69	11	280	32	556	730	24	1120	385
280 MB	4-8	22	71	85	14	280	32	556	730	24	1150	415
315 SA	2	20	62.5	74.5	12	315	32	625	820	28	1123	392
315 SA	4-6	25	81	95	14	315	32	625	820	28	1153	422
315 SMA	2	20	62.5	74.5	12	315	32	625	820	28	1223	392
315 SMA	4-8	25	81	95	14	315	32	625	820	28	1153	422
315 MB, MC	2	20	62.5	74.5	12	315	32	625	820	28	1223	392
315 MB	4-8	25	81	95	14	315	32	625	820	28	1253	422
315 LA, LB	2	20	62.5	74.5	12	315	32	625	820	28	1293	392
315 LA, LB	4-8	25	81	95	14	315	32	625	848	28	1323	422

Tolerances:

A,B	ISO js 14	H	0, -0.5 (M2FA 250)
D	ISO m6		0, -1.0 (M2FA 280-315)
F	ISO h9		

Above table gives the main dimensions in mm.  
For detailed drawings please see our web-site  
[www.abb.com/motors&drives](http://www.abb.com/motors&drives) or contact us.

## Dimension drawings

Foot-mounted; IM B3 (IM 1001), IM B6 (IM 1051), IM B8 (IM 1071), IM V5 (IM 1011)

Terminal box top-mounted

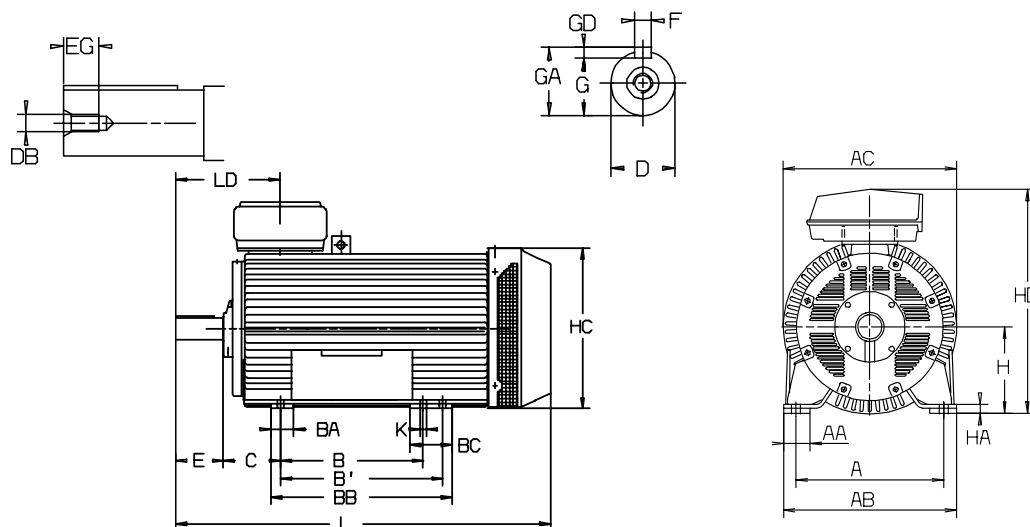

Motor size	Poles	A	AA	AB	AC	B	B'	BA	BB	BC	C	D	DB	E	EG
355 S_	2	610	110	714	716	500	—	100	584	—	254	75	M20	140	40
355 SA	4-8	610	110	714	716	500	—	100	584	—	254	100	M24	210	48
355 SB,SC	4	610	110	714	716	500	—	100	584	—	254	100	M24	210	48
355 SB,SC	6-8	610	110	714	716	500	—	100	584	—	254	100	M24	210	48
355 M_	2	610	110	714	716	560	—	100	644	—	254	75	M20	140	40
355 M_	4	610	110	714	716	560	—	100	644	—	254	100	M24	210	48
355 M_	6-8	610	110	714	716	560	—	100	644	—	254	100	M24	210	48
355 L_	2	610	110	714	716	630	—	100	714	—	254	75	M20	140	40
355 L_	4	610	110	714	716	630	—	100	714	—	254	100	M24	210	48
355 L_	6-8	610	110	714	716	630	—	100	714	—	254	100	M24	210	48
355 LK_	2	610	110	714	716	630	710	100	802	180	254	75	M20	140	40
355 LK_	4-8	610	110	714	716	630	710	100	802	180	254	100	M24	210	48
400 LK_	2	686	140	820	810	710	800	140	935	220	280	90	M24	170	48
400 LK_	4-8	686	140	820	810	710	800	140	935	220	280	100	M24	210	48

Motor size	Poles	F	G	GA	GD	H	HA	HC	HD	K	L	LD
355 S_	2	20	67.5	79.5	12	355	36	713	920	28	1310	397
355 SA	4-8	28	90	106	16	355	36	713	892	28	1380	467
355 SB,SC	4	28	90	106	16	355	36	713	920	28	1380	467
355 SB,SC	6-8	28	90	106	16	355	36	713	892	28	1380	467
355 M_	2	20	67.5	79.5	12	355	36	713	920	28	1370	397
355 M_	4	28	90	106	16	355	36	713	920	28	1440	467
355 M_	6-8	28	90	106	16	355	36	713	892	28	1440	467
355 L_	2	20	67.5	79.5	12	355	36	713	920	28	1450	397
355 L_	4	28	90	106	16	355	36	713	920	28	1520	467
355 L_	6-8	28	90	106	16	355	36	713	892	28	1520	467
355 LK_	2	20	67.5	79.5	12	355	36	713	920	28	1590	397
355 LK_	4-8	28	90	106	16	355	36	713	920	28	1660	467
400 LK_	2	25	81	95	14	400	45	805	1003	35	1786	438
400 LK_	4-8	28	90	106	16	400	45	805	1003	35	1826	478

Tolerances:

A,B	ISO js 14
D	ISO m6
F	ISO h9
H	0, -1.0

Above table gives the main dimensions in mm.

For detailed drawings please see our web-site [www.abb.com/motors&drives](http://www.abb.com/motors&drives) or contact us.



## Dimension drawings

Flange-mounted; IM B5 (IM 3001), IM V1 (IM 3011)

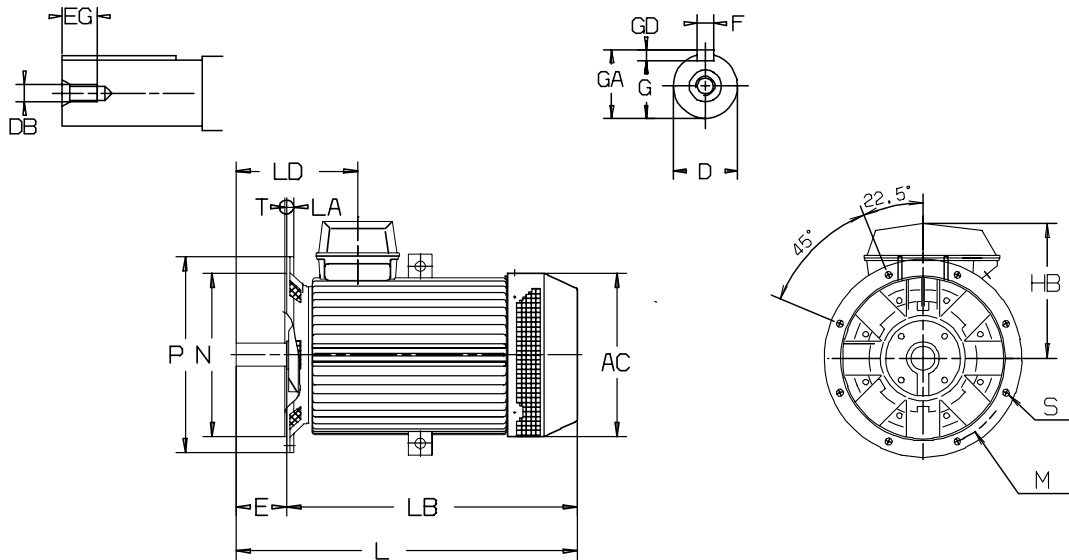

Motor size	Poles	AC	D	DB	E	EG	F	G	GA	GD	HB
250 SA	2	493	65	M20	140	40	18	58	69	11	422
250 SA,SB	4-8	493	75	M20	140	40	20	67.5	79.5	12	422
250 MA	2	493	65	M20	140	40	18	58	69	11	422
250 MA	4-6	493	75	M20	140	40	20	67.5	79.5	12	422
250 MB	4-8	493	75	M20	140	40	20	67.5	79.5	12	422
280 SA	4-8	551	80	M20	170	40	22	71	85	14	450
280 SMA	2	551	65	M20	140	40	18	58	69	11	450
280 SMA	4-8	551	80	M20	170	40	22	71	85	14	450
280 MB	2	551	80	M20	140	40	18	58	69	11	450
280 MB	4-8	551	80	M20	170	40	22	71	85	14	450
315 SA	2	620	70	M20	140	40	20	62.5	74.5	12	505
315 SA	4-6	620	90	M24	170	48	25	81	95	14	505
315 SMA	2	620	70	M20	140	40	20	62.5	74.5	12	505
315 SMA	4-8	620	90	M24	170	48	25	81	95	14	505
315 MB, MC	2	620	70	M20	140	40	20	62.5	74.5	12	505
315 MB	4-8	620	90	M24	170	48	25	81	95	14	505
315 LA	2	620	70	M20	140	40	20	62.5	74.5	12	505
315 LA	4-8	620	90	M24	170	48	25	81	95	14	505
315 LB	2	620	70	M20	140	10	20	62.5	74.5	12	533

Motor size	Poles	L	LA	LB	LD	M	N	P	S	T
250 SA	2	953	22	813	381	600	550	660	23	6
250 SA,SB	4-8	953	22	813	381	600	550	660	23	6
250 MA	2	953	22	813	381	600	550	660	23	6
250 MA	4-6	953	22	813	381	600	550	660	23	6
250 MB	4-8	1023	22	883	381	600	550	660	23	6
280 SA	4-8	1020	25	850	410	600	550	660	23	6
280 SMA	2	1060	25	920	380	600	550	660	23	6
280 SMA	4-8	1090	25	920	410	600	550	660	23	6
280 MB	2	1120	25	980	380	600	550	660	23	6
280 MB	4-8	1150	25	980	410	600	550	660	23	6
315 SA	2	1123	25	983	390	740	680	800	23	6
315 SA	4-6	1153	25	983	420	740	680	800	23	6
315 SMA	2	1223	25	1083	390	740	680	800	23	6
315 SMA	4-8	1153	25	983	420	740	680	800	23	6
315 MB, MC	2	1223	25	1083	390	740	680	800	23	6
315 MB	4-8	1253	25	1083	420	740	680	800	23	6
315 LA	2	1293	25	1153	390	740	680	800	23	6
315 LA	4-8	1323	25	1153	420	740	680	800	23	6
315 LB	2	1293	25	1153	390	740	680	800	23	6

Tolerances:

- D ISO m6
- F ISO h9
- N ISO js6

Above table gives the main dimensions in mm.  
For detailed drawings please see our web-site  
[www.abb.com/motors&drives](http://www.abb.com/motors&drives) or contact us.

## Dimension drawings

Flange-mounted; IM B5 (IM 3001), IM V1 (IM 3011)

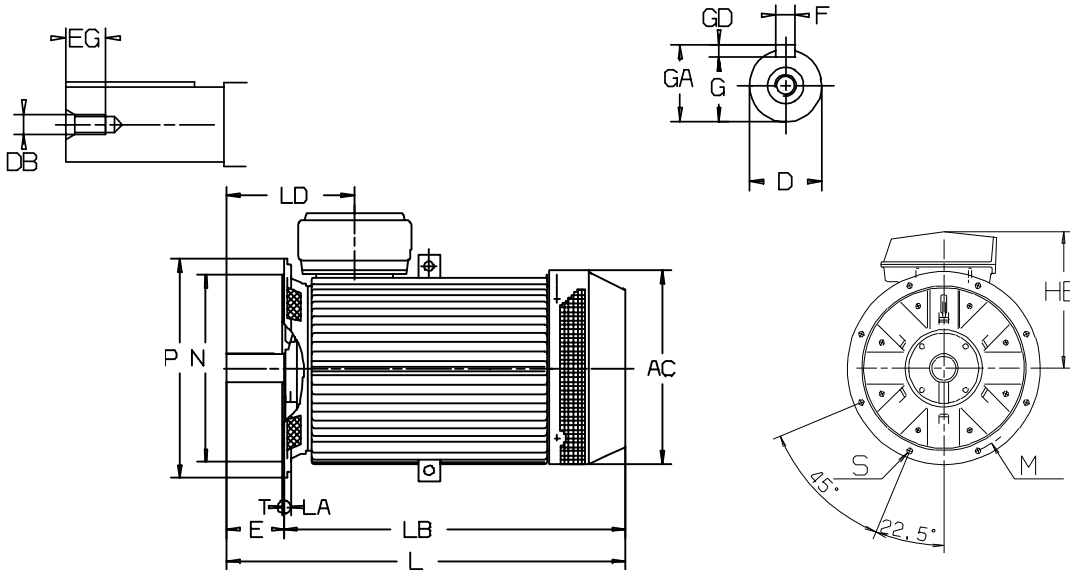

Motor size	Poles	AC	D	DB	E	EG	F	G	GA	GD	HB
355 S_	2	716	75	M20	140	40	20	67.5	79.5	12	565
355 SA	4-8	716	100	M24	210	48	28	90	106	16	537
355 SB,SC	4	716	100	M24	210	48	28	90	106	16	565
355 SB,SC	6-8	716	100	M24	210	48	28	90	106	16	537
355 M_	2	716	75	M20	140	40	20	67.5	79.5	12	565
355 M_	4	716	100	M24	210	48	28	90	106	16	565
355 M_	6-8	716	100	M24	210	48	28	90	106	16	537
355 L_	2	716	75	M20	140	40	20	67.5	79.5	12	565
355 L_	4	716	100	M24	210	48	28	90	106	16	565
355 L_	6-8	716	100	M24	210	48	28	90	106	16	537
355 LK_	2	716	75	M20	140	40	20	67.5	79.5	12	565
355 LK_	4-8	716	100	M24	210	48	28	90	106	16	565
400 LK_	2	810	90	M24	170	48	25	81	95	14	565
400 LK_	4-8	810	100	M24	210	48	28	90	106	16	565

Motor size	Poles	L	LA	LB	LD	M	N	P	S	T
355 S_	2	1310	25	1170	395	740	680	800	23	6
355 SA	4-8	1380	25	1170	465	740	680	800	23	6
355 SB,SC	4	1380	25	1170	465	740	680	800	23	6
355 SB,SC	6-8	1380	25	1170	465	740	680	800	23	6
355 M_	2	1370	25	1230	395	740	680	800	23	6
355 M_	4	1440	25	1230	465	740	680	800	23	6
355 M_	6-8	1440	25	1230	465	740	680	800	23	6
355 L_	2	1450	25	1310	395	740	680	800	23	6
355 L_	4	1520	25	1310	465	740	680	800	23	6
355 L_	6-8	1520	25	1310	465	740	680	800	23	6
355 LK_	2	1590	25	1450	395	740	680	800	23	6
355 LK_	4-8	1660	25	1450	465	740	680	800	23	6
400 LK_	2	1786	28	1616	438	940	880	1000	28	6
400 LK_	4-8	1826	28	1616	478	940	880	1000	28	6

Tolerances:

D	ISO m6
F	ISO h9
N	ISO js6

Above table gives the main dimensions in mm.  
For detailed drawings please see our web-site  
[www.abb.com/motors&drives](http://www.abb.com/motors&drives) or contact us.

# General purpose open drip proof motors

## Dimension drawings

Terminal box in standard design  
with 6 terminals

Top-mounted terminal box:

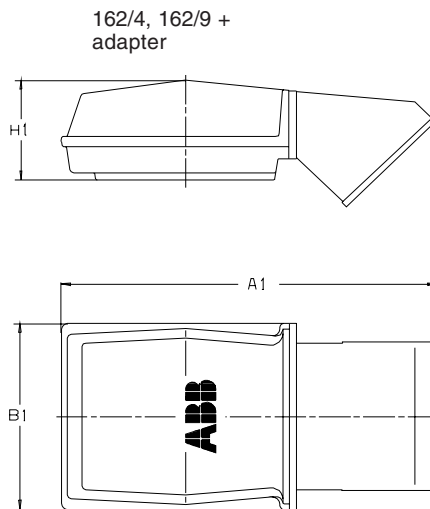
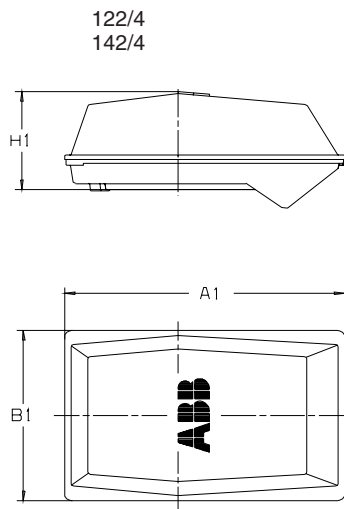

Side-mounted terminal box:

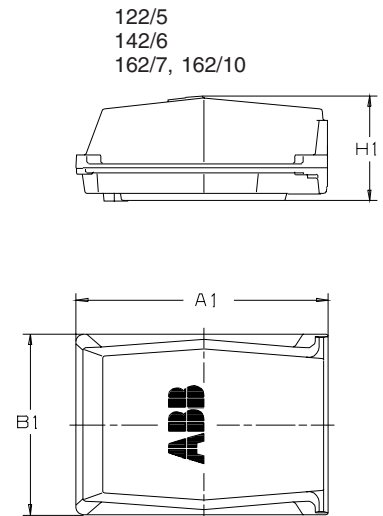

Terminal box type	Motor size	A1	B1	H1
-------------------	------------	----	----	----

Top-mounted terminal box:

122/4	250 - 280	455	280	177
142/4	315 - 355	536	349	197
162/4, 162/9 + Adapter	315 - 400	787	410	226

Side-mounted terminal box:

122/5	250 - 280	383	280	180
142/6	315 - 355	426	347	201
162/7, 162/10	315 - 400	508	412	226

Further details on terminal boxes on earlier pages.  
For motor dimensions please see dimension drawings on  
earlier pages.

## Rating plate

The rating plate is in table form giving values for speed,  
current and power factor for six voltages.

ABB Oy, Electrical Machines LV Motors, Vaasa, Finland							
CE							
3 ~ Motor M2FA 315 MB 4 B3							
IEC 315 S/M 80							
No. 0320-010119452							
Ins. cl. F IP 23 S							
V	Hz	kW	r/min	A	cos φ	Duty	
690 Y	50	250	1481	261	0,83	S1	
400 D	50	250	1481	452	0,83	S1	
660 Y	50	250	1479	271	0,86	S1	
380 D	50	250	1479	470	0,86	S1	
415 D	50	250	1482	441	0,83	S1	
440 D	60	287	1779	460	0,86	S1	
Prod. code 3GFA312210-ADA							
Nmax r/min							
6319/C3				6316/C3		850 kg	
ABB IEC 60034-1							

# General purpose open drip proof motors in brief, basic design

Motor frame size		250	280	315	355	400
<b>Stator</b>	Material	Profile-pressed sheet steel				
	Paint colour shade Paint thickness	Blue, Munsell 8B 4.5/3.25 / NCS 4822-B05G Two-pack epoxy paint, thickness $\geq 70 \mu\text{m}$				
<b>Bearing end shields</b>	Material	Cast iron GG 20/GRS 200				
	Paint colour shade Paint thickness	Blue, Munsell 8B 4.5/3.25 / NCS 4822-B05G Two-pack epoxy paint, thickness $\geq 70 \mu\text{m}$				
<b>Bearings</b>	D-end      2-pole 4-12 poles	6316/C4 6316/C3	6316/C4 6319/C3	6316/C4 6319/C4	on request 6322/C3	on request 6322/C3
	N-end      2-pole 4-12 poles	6316/C4 6316/C3	6316/C4 6316/C3	6316/C4 6316/C3	on request 6319/C3	on request 6319/C3
<b>Axially-locked bearings</b>	Inner bearing cover	As standard, locked at D-end				
<b>Bearing seal</b>		V-ring as standard, radial seal on request				
<b>Lubrication</b>		Regreasing nipples, M10x1 Grease for bearing temperatures $-30^{\circ}\text{C}$ to $+120^{\circ}\text{C}$				
<b>Rating plate</b>		Stainless steel, with individual serial number				
<b>SPM-nipples</b>		On request				
<b>Terminal box</b>	Frame material	Cast iron GG 15 / GRS 150				
	Cover material Cover screw material	Cast iron GG 15 / GRS 150 Steel 5G, coated with zinc and yellow chromated				
<b>Connections</b>	Cable entries      2, 4 pole	2xPg42	2xPg42	2xPg48 Ø60	2xPg48 Ø45/55/70	2xPg48 Ø45/55/70/80
	6 pole	2xPg36/42	2xPg436/42			
	Terminals	6 terminals for connection with cable lugs (not included)				
<b>Fan</b>	Material	Siluminium				
<b>Fan cover</b>	Material	Sheet steel				
	Paint colour shade Paint thickness	Blue, Munsell 8B 4.5/3.25 / NCS 4822-B05G Two-pack epoxy polyester paint, thickness $\geq 80 \mu\text{m}$				
<b>Stator winding</b>	Material	Copper				
	Insulation	Insulation class F; temperature rise class B unless otherwise stated.				
	Winding protection	PTC-thermistors $150^{\circ}\text{C}$ , 3 in series, as standard				
<b>Rotor winding</b>	Material	Pressure die-cast aluminium				
<b>Balancing method</b>		Half key balancing as standard				
<b>Key way</b>		Closed key way				
<b>Heating elements</b>	On request	50 W	50 W	2x50 W	2x65 W	2x65 W
<b>Drain holes</b>		As standard, open on delivery				
<b>Enclosure</b>		IP 23S				
<b>Cooling method</b>		IC 01				



# Drive<sup>IT</sup> General Purpose Brake Motors

Totally enclosed squirrel cage three phase low voltage motors,  
Sizes 63 - 180, 0.055 to 22 kW

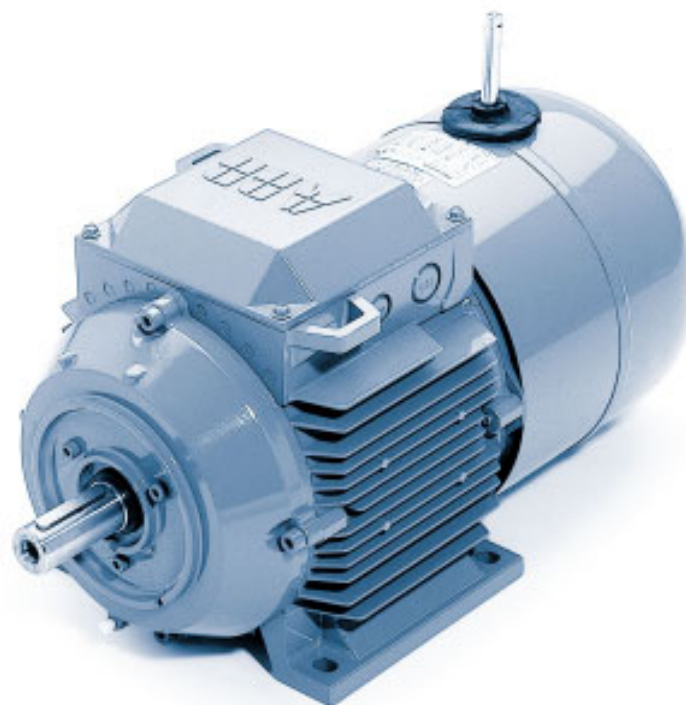

<b>Mechanical design.....</b>	<b>166</b>
<b>Ordering information.....</b>	<b>173</b>
<b>Technical data.....</b>	<b>174</b>
<b>Variant codes.....</b>	<b>186</b>
<b>Rating plates.....</b>	<b>186</b>
<b>Dimension drawings.....</b>	<b>187</b>
<b>Brake motors in brief.....</b>	<b>189</b>

# Mechanical design

## Degrees of protection

The degrees of protection, as per IEC standards 60034-5, are: terminal box and electrical components of the brake – IP 55; other motor parts – IP 55.

Mechanical components of the brake – IP 23 S.

Mechanical parts of the brake, protected with a rubber ring and V-ring – IP 55 (optional: variant code 213).

## Mounting arrangements of brake motors

The design of the brake motor enables it to operate in any mounting position. Nevertheless, the position of the drain holes should be taken into account.

Vertically mounted motors with the shaft end downwards, intended for outdoor operation, should be provided with a protective roof to avoid water ingress and the possibility of ice forming on the brake.

## Operation

ABB's brake motor is a standard motor modified for braking duties, i.e. a three phase induction motor with standard dimensions and output rating.

The electro-magnetic disc brake is powered, by either DC or three phase AC current, from a rectifier located in the motor terminal box.

When the brake coil is de-energised, the brake is actuated by spring pressure.

The axial movement of the brake disc performs a dual braking action against the moving electromagnet and the motor shield, without pressure or impact being transmitted to the bearings.

The brake linings withstand high temperatures, have great wear resistance and give long life. Because of the very low wear of the braking disc, the brakes of the ABB motor usually require only one-third of the maintenance required by other common brake types in the market.

## Lubrication and bearings

The bearings incorporate two Z-type non-friction sealing plates. The amount of grease is sufficient for the life of the bearing.

The motors are fitted with the bearings listed in the table.

Motor size	D-end	N-end
<b>M3VRF/S 63 A, B, BB</b>	6202-2Z/C3	6202-2Z/C3
<b>63 MA, MB</b>	6201-2Z	6201-2Z
<b>71</b>	6203-2Z/C3	6203-2Z/C3
<b>80</b>	6204-2Z/C3	6204-2Z/C3
<b>M3ARF/S 90</b>	6205-2Z/C3	6205-2Z/C3
<b>100</b>	6306-2Z/C3	6206-2Z/C3
<b>112</b>	6206-2Z/C3	6206-2Z/C3
<b>132</b>	6208-2Z/C3	6208-2Z/C3
<b>160</b>	6309-2Z/C3	6209-2Z/C3
<b>180</b>	6310-2Z/C3	6209-2Z/C3

# Brake design

## General

Electromagnetic disc brakes work by the action of a set of springs and are released when applying voltage to the brake coil.

This means that the motor will brake automatically in

case of any voltage failure, as a significant safety feature. The brake is always functional, irrespective of the mounting position of the brake motor. The external dimensions for both the DC and the three phase AC brake are identical.

## Detailed view

- 1 Rectifier (DC brake only)
- 2 Motor N-end shield
- 3 Screw
- 4 Brake disc
- 5 Dust protection (optional)
- 6 Armature
- 7 Hand release
- 8 Hand release bellows
- 9 Air gap regulation screw
- 10 Magnet
- 11 Fan cover
- 12 Fan
- 13 Torque regulation screw

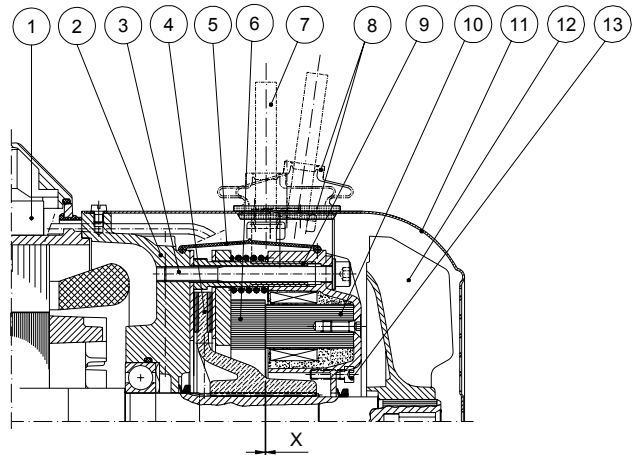

## Brake disc

The brake lining is made from asbestos-free material. It is highly resistant to wear and has excellent thermal conductivity, thus giving consistent performance even at high temperatures.

The brake disc withstands a large number of braking operations and is insensitive to dust and moisture.

The core of the brake disc is grooved and made of special polyamide that absorbs impacts, enabling it to work with high vibration applications.



## Readjusting the air gap

The brakes are supplied with the air gap adjusted to its nominal value.

The air gap has to be readjusted to its nominal value when the wear of the lining reaches the readjustment value ( $X_n$ ) stated in table 1.

For this operation, work on the bushings (9) after releasing the bolts (3).

Tighten up the bushings in the magnet support (10) as required to reach the rated air gap value stated in table 1.

Tighten the bolts (3) to the specific torque, C (see table 1).

At the end of the operation, check that the air gap complies with the specified value and is uniform across the whole surface.

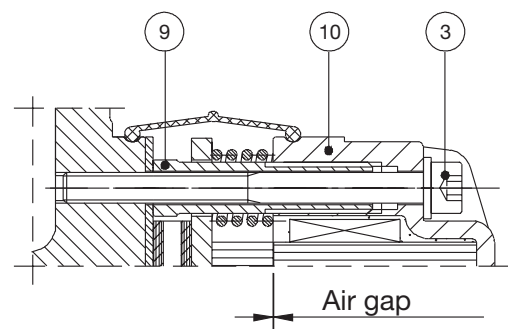

## Replacing the brake disc

The brake disc must be replaced when reaching the minimum permissible lining thickness stated in Table 1.

## Connection for DC brake

The brake is fed via a rectifier. The voltage stated on the brake rating plate is that of the brake coil on the DC side of the rectifier.

### Standard connection (t'21~)

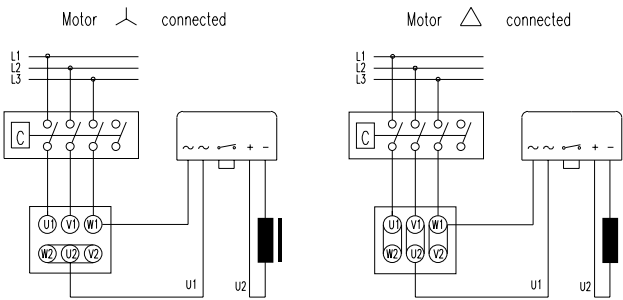

### Reconnection (t21~)

When it is necessary to reduce the braking time, the connections should be modified according to the following diagram. The breaking of the circuit on the AC side is controlled by using an auxiliary contact of the contactor.

## Rectifier

The rectifier is a device for DC brake applications. It is highly resistant to temperature as well as to voltage peaks, and it includes an additional protection of the auxiliary contact of contactor. Its compact design enables it to be placed in the motor terminal box.

The coil can operate reliably between of 90% and 110% of the rated voltage. For voltages outside these limits, please consult ABB.

### Reconnection (t21=)

To obtain instant braking, please see table 2 (t21=), use the following diagram.

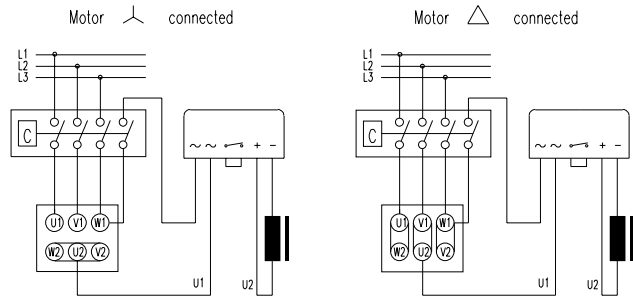
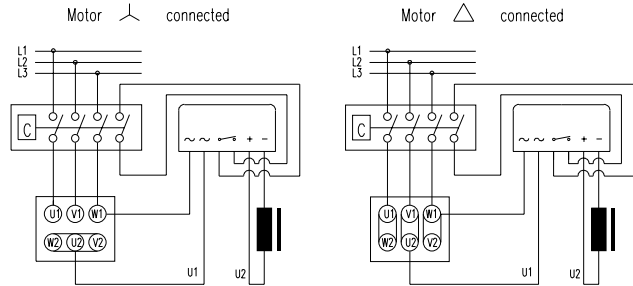

## Connection of AC brake

The coil should only be used between 90% - 110% of its rated voltage.

### Standard connection (t21)

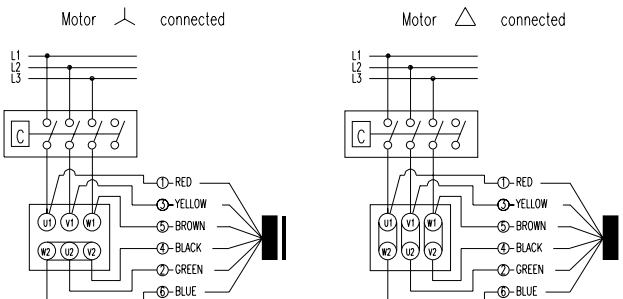

### Reconnection (t21f)

To obtain instant braking, the coil must be fed separately from the motor terminals.

### Remark:

Regardless of whether a DC or AC brake is used, the brake is usually connected to the motor terminals of single-speed motors. It can, however, also be delivered with a separate brake supply (variant code 086). In case of two-speed motors, the brake is always connected separately.



## Hand release

The device is a lever used to override the action of the brake springs for as long as it is applied.

Hand release is included as standard, except for frame size 63, where it is available as option, see variant code 088.

When installing the release lever, please proceed as follows:

Remove the rubber protection, if fitted. Insert the screw (1) with its washer, position the spring (2) and washer (3) and tighten the nut (4) firmly. Fit the other washer and the square-head nut (5); adjust the position of the nut in relation to the moving magnet (Y value) with the central screw (1). When the required value is reached, tighten the inner nut (4) while holding nut (5) fixed.

**Important:** The use of the release lever necessitates periodic checking of the Y value and the air gap. The air gap should never exceed the maximum values stated in brake data table 1. Failure to check could result in malfunction due to mechanical locking of the armature.

Size	Y
FM 075.5	1
FM 088.6	1
FM 100.6	1
FM 120.6	1
FM 140.6	1.5
FM 155.6	1.5
FM 170.6	1.5
FM 206.6	1.5

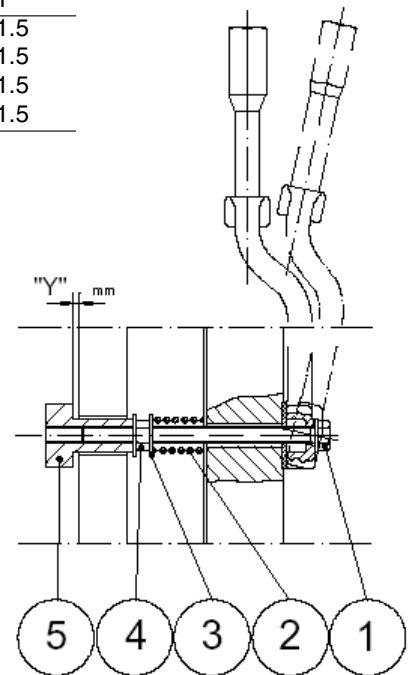

## Torque adjustment

In brake motors from frame size 71 up to 180, the braking torque can be adjusted from 100% up to 55% of the nominal torque as standard.

Instructions for how to regulate torque are delivered with the brake motor. These instructions describe how to loosen the torque regulation screw (13), as well as the relation between dimension A and torque.

The braking torque is also adjustable as standard for frame sizes 63 MA and MB, having a torque range from 100% down to 10% of the nominal torque.

Reduced braking torque, from 60% up to 33%, is available by using variant code 087 (applies for frame sizes 71-180).

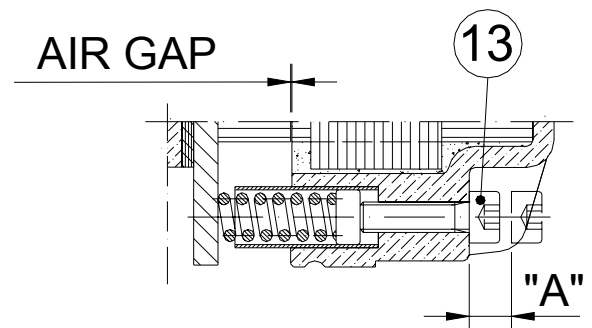

## Brake operating times

The operating times stated in brake data table 2 are valid for the nominal air gap and warmed-up brake coil.

$t_1$  = Brake release time.

$t_{21}$  = Braking time.

$U_2$  = Rated voltage.

$T_B$  = Nominal braking torque.

Brake release time = the time from when voltage is applied to the brake coil up to the ceasing of braking action.

Braking time = the time from when the current is switched off up to the starting of braking action.

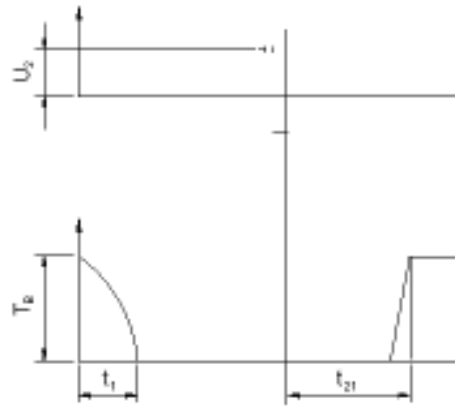

## Special brakes (with DC brake)

Two-speed motors with one or two windings, motors with 9 or 12 terminals, and motors that have to be started with star-delta connection, with brake coil for DC, are supplied with the rectifier fitted in the motor terminal box, without the two wires that normally connect it to the motor terminal. The AC supply to the rectifier is independent to the motor supply and should be fed by the main contactor.

The standard brake coil connection voltages for 50 and 60 Hz will be those stated in the following table, unless stated otherwise in the order:

<sup>1)</sup> H.W. = Half-wave rectifier, F.W. = Full-wave rectifier

<sup>2)</sup> Special coil on request

<sup>3)</sup> Available using variant code 285

Rectifier input voltage (V <sub>AC</sub> )	Rectifier type <sup>1)</sup>	D.C. coil brake voltage (V)
110	F.W.	102 <sup>2)</sup>
220	F.W.	205
230	F.W.	205
240	F.W.	205
250	F.W.	223 <sup>2)</sup>
254	F.W.	223 <sup>2)</sup>
380	H.W.	178
400	H.W.	178
415	H.W.	178
420	H.W.	178
440	H.W.	205
500	H.W.	223 <sup>2)</sup>
24 V <sub>DC</sub>	None	24 <sup>3)</sup>

# Brake data tables

**Table 1.**

Brake motor size		M3VRF 63M_	M3VRS 63M_	63 A/B	71	80	90	100	112	132	160/180 2 p 4-8 p
Brake type		K01	AC1	075.5	088.6	100.6	120.6	140.6	155.6	170.6	206.6
Rated torque <sup>1)</sup>	$T_{Bnom}$ (Nm)	4.5	4.5	7.5	10	24	35	44	86	130	200 230
Delivered torque <sup>2)</sup>	$T_{Bmin}$ (Nm)	4	4	4	8	21	30	38	72	120	130 200
Nominal air gap	X (mm)	0.2	0.2	0.2	0.2	0.25	0.35	0.4	0.4	0.4	0.4
Minimum permissible brake disc thickness	(mm)	3	3	3.5	3.5	5	5.5	6	6	7.5	8.5
Recommended air gap readjustment	$X_n$ (mm)	0.7	0.7	0.5	0.5	0.6	0.7	0.8	0.8	0.8	0.9
Thickness of new brake disc	$E_m$ (mm)	7	7	5.5	6	7.5	8.5	9.5	9.5	11	13
Tightening torque: bolt	$C_s$ (Nm)	6	6	6	6	12	12	30	30	30	50
Input coil:											
- AC brake motor	(VA)	–	40	60	110	160	250	500	700	990	2000
- DC brake motor	(W)	15	–	30	32	45	72	91	100	120	170
Friction work per operation	$WR_{max}$ (J)	$1 \times 10^3$	$1 \times 10^3$	$1 \times 10^3$	$1.5 \times 10^3$	$2 \times 10^3$	$3.5 \times 10^3$	$6.6 \times 10^3$	$8 \times 10^3$	$1.1 \times 10^4$	$2 \times 10^4$
Friction work	$PR_{max}$ (J/h)	$3 \times 10^5$	$3 \times 10^5$	$3 \times 10^5$	$3.5 \times 10^5$	$4.5 \times 10^5$	$7 \times 10^5$	$9 \times 10^5$	$9.5 \times 10^5$	$1 \times 10^6$	$1.2 \times 10^6$
Operation for thickness wear of 0.1 mm	$WR_{0.1}$ (J)	$7 \times 10^6$	$7 \times 10^6$	$7 \times 10^6$	$10 \times 10^6$	$15 \times 10^6$	$17 \times 10^6$	$31 \times 10^6$	$31.5 \times 10^6$	$48 \times 10^6$	$80 \times 10^6$
Moment of inertia	J (kgm <sup>2</sup> )	$1.5 \times 10^{-5}$	$1.5 \times 10^{-5}$	$1.5 \times 10^{-5}$	$3.7 \times 10^{-5}$	$7.5 \times 10^{-5}$	$2 \times 10^{-4}$	$3.7 \times 10^{-4}$	$6.2 \times 10^{-4}$	$10.4 \times 10^{-4}$	$26.4 \times 10^{-4}$
Weight	(kg)	1.2	1.2	0.8	1	1.6	2.7	4	5.2	9	16.2

<sup>1)</sup> Braking torque after performing 10.000-15.000 operations.

<sup>2)</sup> Delivered torque : Torque value marked on rating plate corresponding to the braking torque when the brake motor leaves the ABB factory. Tolerance of +/-10% of this value is accepted. Ambient conditions, temperature on friction surfaces, brake motor positioning and transport applied on the product can affect this value.

In general, all the variables mentioned above can affect the braking torque values, so if an accurate value is needed, ABB recommends it is measured in the real application. This allows adjustment to the required value by using the torque regulation facility.

**Table 2.**

## Braking ( $t_{21}$ ) and release ( $t_1$ ) times

Brake motor sizes		M3VRF 63 M_	M3VRS 63 M_	63 A/B	71	80	90	100	112	132	160/180
Brake type		K01	AC1	075.5	088.6	100.6	120.6	140.6	155.6	170.6	206.6
<b>AC brake coil</b>											
- release time	$t_1$ (ms)	–	10	5	6.6	5	5.1	5.5	5	5	5.5
- standard braking time	$t_{21}$ (ms)	–	25	25	25	30	40	50	50	65	105
- fast braking time	$t_{21f}$ (ms)	–	10	10	10	10	10	10	10	10	10
<b>DC brake coil</b>											
- release time	$t_1$ (ms)	45	–	20	20	25	35	40	50	60	100
- std connection time	$t'_{21}$ (ms)	–	–	150	170	210	330	420	720	850	930
- reconnection time	$t_{21}$ (ms)	–	–	30	35	45	70	90	155	190	150
- fast reconnection time	$t_{21=}$ (ms)	15	–	10	10	15	20	35	45	55	85

When fast braking in AC brake is used, the contactor that is operating the coil of the brake has to be over dimensioned taking in consideration a high inductive load.

# Calculations

## Maximum number of connections per hour

The connection frequency that may be achieved with the motors is limited by the temperature rise that they undergo both in the coil and in the rotor. The brakes are designed so that they may withstand the kinds of duty for which these motors are intended.

The maximum number of connections per hour depends on:

- the power  $P_2$  required after reaching the rated speed, i.e. the relative load  $P$  with regard to the rated power  $P_n$ .

$$P = \frac{P_2}{P_n} \times 100 \%$$

- the total inertia  $J$  in  $\text{kgm}^2$  of the mass to be accelerated (inertia of the rotor  $J_m$  as per catalogue, plus the additional inertia  $J_b$  of the driven machine) in relation to the motor shaft, that is,  $J_b$  multiplied by the square of the coefficient of the load speed divided by the motor speed.

$$J = J_m + \left[ J_b \times \left[ \frac{n_b}{n_m} \right]^2 \right]$$

- the relative duration factor for service S4.

$$S4 = \frac{\text{connection time}}{\text{connection time} + \text{downtime}} \times 100 \text{ in } \%$$

For calculations of the maximum number of connections/hour, please consult ABB.

Required data:

- Type of brake motor
- Load inertia reduced at motor shaft
- Required power  $P_2$
- Type of service

## Options

### Separate brake supply

For brakes which need an independent supply, please note the variant code 086 and the voltage for feeding the brake. When the motor is supplied via a frequency converter, both in the case of DC and AC, the brake should be supplied separately at rated voltage (constant). The separate brake supply can be connected directly, no separate terminal box is needed.

### Dust protection

To protect the brake disc against dust, the brake can be supplied with a rubber protection ring and V-ring.

Variant code 213 should be stated in the order.

## Permitted friction work per operation

Friction work per operation must not exceed the  $WR_{\max}$  values stated in brake data table 1.

$$WR = \frac{1}{2} \times J \left[ \frac{\pi \times n_m}{30} \right]^2 \text{ in joules}$$

## Friction work per hour

The friction work can be calculated if the number of operations per hour is known.

This value must be equal to or less than the  $PR_{\max}$  stated in brake data table 1.

$$PR = WR \times c/h$$

## Braking time

The total braking time from the disconnecting of brake until the machine is stopped is calculated as follows:

$$t = 104.6 \times \frac{J \times n_m}{T_B} + t_{21}$$

$t$  and  $t_{21}$  are in ms

## Maximum number of operations until wear of 0.1 mm

The service life, expressed in switching operations, can be calculated with the aid of the values  $WR_{0.1}$  given in brake data table 1.

$$L_{0.1} = \frac{WR_{0.1}}{WR}$$

## Number of operations before readjusting the air gap

With the  $X_n$  values in table 1 we can calculate the number of required operations until the readjustment of air gap becomes necessary.

$$Ln = \frac{X_n - X}{0.1} \times L_{0.1}$$

## Braking torque reduction

Reduced braking torque range, from 60% up to 33%, is available by using variant code 087.

## Protective roof

To protect motors from accumulation of water, ice or snow when installed outdoors in the vertical position and with the shaft downwards, the assembly should be fitted with a protective roof.

Variant code 005 should in this case be stated in the order.

# Ordering information

## Sample order

When placing an order, please state the following minimum data in the order, as in the example.

The product code of the motor is composed in accordance with the following example.

Motor type	M3ARF 112M
Pole number	4
Mounting arrangement (IM-code)	IM B3 (IM 1001)
Rated output	4 kW
Product code	3GAR112401-ADE
Variant codes if needed	
Brake information	

<b>A</b>	<b>B</b>	<b>C</b>	<b>D,E,F, G</b>					
<b>M3ARF 112 M</b>		<b>3GAR 112 401 - ADE, 088 etc.</b>						
		1 - 4	5 - 6 7	8 - 10	11	12	13   14	<b>A</b> Motor type M3VRF/M3ARF (DC brake) M3VRS/M3ARS (AC brake) <b>B</b> Motor size <b>C</b> Product code <b>D</b> Mounting arrangement code <b>E</b> Voltage/frequency code <b>F</b> Generation code <b>G</b> Variant code

### Explanation of the product code:

#### Positions 1 and 2

**3G** = Business Area LV Motors

#### Position 3

**A** = Totally enclosed motor, aluminium frame

**V** = Totally enclosed motor, aluminium frame, alternative design

#### Position 4

**R** = Brake motor

#### Positions 5 and 6

##### IEC-size

**06** = 63                      **12** = 112

**07** = 71                      **13** = 132

**08** = 80                      **16** = 160

**09** = 90                      **18** = 180

**10** = 100

#### Position 7

##### Speed (Pole pairs)

**1** = 2 poles                  **6** = 12 poles

**2** = 4 poles                  **7** = > 12 poles

**3** = 6 poles                  **8** = Two-speed motors

**4** = 8 poles                  **9** = Multi-speed motors

**5** = 10 poles

#### Position 8 to 10

Serial number

#### Position 11

-(dash)

#### Position 12

##### Mounting arrangement

**A** = Foot-mounted.

**B** = Flange-mounted. Large aluminium flange with clearance holes, sizes 63-100 and 180.

**C** = Flange-mounted. Small aluminium flange with tapped holes, sizes 63-100.

**E** = Flange-mounted. Large cast iron flange with clearance holes, sizes 112-160.

**H** = Foot- and flange-mounted. Large aluminium flange with clearance holes, sizes 63-100 and 180.

**J** = Foot- and flange-mounted. Small aluminium flange with tapped holes, sizes 63-100.

**K** = Foot- and flange-mounted. Large cast iron flange with clearance holes, sizes 112-160.

**N** = Flange mounted. Two piece cast iron flange (IEC-1) with clearance holes, sizes 90-132.

**P** = Foot- and flange-mounted. Two piece cast iron flange (IEC) with clearance holes, sizes 90-132.

#### Position 13

##### Voltage and frequency code

See table below

#### Position 14

Generation code = **C** (size 63), **E** (sizes 71-180)

**The product code must be, if needed, followed by variant codes.**

# General purpose brake motors

## Technical data for single-speed DC brake motors

IP 55 – IC 411 – Insulation class F, temperature rise class B – Brake IP 23 S

Output Motor kW type	Product code	Torque							Efficiency		Power factor cos φ	Current			Moment of inertia J=1/4GD <sup>2</sup> kgm <sup>2</sup>	Weight Foot mounted kg	
		Speed r/min	TN Nm	braking TB Nm	TS/ TN	K <sup>1)</sup>	100%	75%	IN A	IS/IN		c/h <sup>2)</sup>					
<b>3000 r/min = 2 poles</b>		<b>400 V 50 Hz</b>							<b>Basic design</b>								
0.18	M3VRF 63 A	3GVR 061 401-••C	2820	0.62	7.5	3.5	12.5	73.7	70.6	0.64	0.56	4.2	3500	0.00023	4.9		
0.18	M3VRF 63 MA	3GVR 061 411-••C	2800	0.62	4.5	2.3	7.3	64.0	63.0	0.80	0.51	4.2	3500	0.00022	5		
0.25	M3VRF 63 B	3GVR 061 402-••C	2810	0.87	7.5	3.6	8.33	77.5	75.8	0.71	0.66	4.5	3500	0.00026	5.4		
0.25	M3VRF 63 MB	3GVR 061 412-••C	2800	0.86	4.5	2.2	5.2	68.0	66.0	0.83	0.64	4.2	3500	0.00028	6		
0.37	M3VRF 71 A	3GVR 071 401-••E	2840	1.25	10	3.8	7.6	77.1	76.5	0.72	1.0	5.5	2600	0.00051	7		
0.55	M3VRF 71 B	3GVR 071 402-••E	2830	1.86	10	3.6	5.26	79.2	78.2	0.76	1.35	5.7	2600	0.0006	8		
0.75	M3VRF 80 A	3GVR 081 401-••E	2870	2.49	24	2.9	9.6	81.2	79.3	0.75	1.8	6.2	2000	0.00074	11		
1.1	M3VRF 80 B	3GVR 081 402-••E	2850	3.69	24	2.3	6.48	81.4	79.5	0.78	2.5	6.1	2000	0.00078	12		
1.5	M3ARF 90 S	3GAR 091 401-••E	2870	5.0	35	2.4	7.0	80.1	76.2	0.82	3.35	5.5	1300	0.0021	19		
2.2	M3ARF 90 L	3GAR 091 402-••E	2880	7.5	35	2.7	4.7	83.6	83.9	0.87	4.37	7.0	1200	0.0026	22		
3	M3ARF 100 L	3GAR 101 401-••E	2900	10	44	2.7	4.4	86.0	84.1	0.88	5.95	7.5	1000	0.00453	32		
4	M3ARF 112 M	3GAR 111 401-••E	2850	13.4	86	2.8	6.41	86.0	86.2	0.91	7.4	7.5	500	0.01078	38		
5.5	M3ARF 132 SA	3GAR 131 401-••E	2855	18.4	130	3.2	7.06	86.0	86.6	0.88	10.5	7.8	600	0.01657	57		
7.5	M3ARF 132 SB	3GAR 131 402-••E	2860	25.1	130	3.4	5.17	88.0	86.2	0.89	13.9	8.5	500	0.01857	62		
11	M3ARF 160 MA	3GAR 161 411-••E	2915	36	200	2.1	5.55	88.4	88.0	0.88	20.5	6.1	200	0.05096	124		
15	M3ARF 160 M	3GAR 161 412-••E	2900	49	200	2.3	4.1	89.4	89.7	0.90	27	6.0	200	0.05596	134		
18.5	M3ARF 160 L	3GAR 161 413-••E	2915	60	200	2.5	3.3	90.4	90.7	0.91	32.5	6.7	200	0.06396	139		
22	M3ARF 180 M	3GAR 181 411-••E	2925	72	200	3.0	2.8	91.5	91.7	0.89	39	8.0	120	0.06264	158		
<b>3000 r/min = 2 poles</b>		<b>400 V 50 Hz</b>							<b>High-output design</b>								
0.37	M3VRF 63 BB	3GVR 061 403-••C	2800	1.29	7.5	2.3	5.76	73.6	73.1	0.81	0.9	3.5	3500	0.00027	5.9		
0.68	M3VRF 71 BB	3GVR 071 403-••E	2800	2.33	10	3.2	4.34	78.9	77.4	0.82	1.59	5.2	2400	0.0006	8		
0.75	M3VRF 71 BC	3GVR 071 404-••E	2800	2.57	10	3.1	3.84	78.5	77.9	0.85	1.7	5.1	2400	0.0006	8		
1.5	M3VRF 80 C	3GVR 081 403-••E	2840	5.13	24	2.8	4.7	82.4	82.2	0.83	3.16	5.5	1800	0.00111	13		
2.7	<sup>3)</sup> M3ARF 90 LB	3GAR 091 403-••E	2860	9.0	35	2.6	3.88	80.7	83.5	0.86	5.7	7.0	1200	0.0029	24		
4	<sup>3)</sup> M3ARF 100 LB	3GAR 101 402-••E	2900	13	44	2.7	3.38	85.0	84.3	0.86	8.1	7.5	1000	0.00543	36		
5.5	<sup>3)</sup> M3ARF 112 MB	3GAR 111 402-••E	2855	18.4	86	2.7	4.67	86.5	87.1	0.93	9.9	7.3	500	0.01273	66		
9.2	<sup>3)</sup> M3ARF 132 SBB	3GAR 131 404-••E	2825	31.1	130	3.2	4.18	86.0	88.2	0.93	16.6	7.3	500	0.02457	77		
11	<sup>3)</sup> M3ARF 132 SC	3GAR 131 403-••E	2835	37	130	3.2	3.51	87.0	87.4	0.93	19.6	8.0	500	0.02383	77		
22	<sup>3)</sup> M3ARF 160 LB	3GAR 161 404-••E	2920	72	200	2.6	2.77	92.1	92.1	0.91	38	7.1	200	0.06896	145		

<sup>1)</sup> Braking-torque ratio

<sup>2)</sup> No-load (shaft-free) operations/hour

<sup>3)</sup> Temperature rise class F.

The bullets in the product code indicate choice of mounting arrangement and voltage and frequency code, see below and ordering information page.

### Code letters for supplementing product code for mounting arrangement:

Foot-mounted **A**  
 Flange-mounted, 1 flange **B** for frame sizes 63-100, 180; **E** for frame sizes 112-160.  
 Flange-mounted, 2 flanges **N** for frame sizes 90-132  
 Flange-mounted, small flange **C** for frame sizes 63-100

### Code letters for supplementing product code for voltage and frequency (pos 13):

Motor size	<b>S</b> Motor			<b>D</b> Motor			<b>X</b>
	50 Hz	60 Hz	Brake (input rectifier voltage/brake voltage)	50 Hz	60 Hz	Brake (input rectifier voltage/brake voltage)	
<b>63-132</b>	220-240 VΔ 380-420 VY	250-280 VΔ	220-240 V/205 V d.c.	380-420 VΔ 660-690 VY	440-480 VΔ	380-420 V/178 V d.c.	Any other rated voltage or frequency, 690 V maximum connection for motor and 500 V for brake (input rectifier)
<b>160-180</b>	230 VΔ 400 VY	265 VΔ	230 V/205 V d.c.	400 VΔ 690 VY	460 VΔ	400 V/178 V d.c.	
Motor size	<b>E</b> Motor			<b>F</b> Motor			
	50 Hz		Brake (input rectifier voltage/brake voltage)	50 Hz		Brake (input rectifier voltage/brake voltage)	
<b>63-80</b>	–	–	–	500 VY	–	500 V/223 V d.c.	
<b>90-180</b>	500 VΔ	–	500 V/223 V d.c.	500 VY	–	500 V/223 V d.c.	

# General purpose brake motors

## Technical data for single-speed DC brake motors

IP 55 – IC 411 – Insulation class F, temperature rise class B – Brake IP 23 S

Output kW	Motor type	Product code	Torque						Efficiency		Power factor cos φ	Current			Moment of inertia J=1/4GD <sup>2</sup> kgm <sup>2</sup>	Weight Foot mounted kg
			Speed r/min	rated TN Nm	braking TB Nm	TS/ TN	K <sup>1)</sup>	100%	75%	IN A		IS/IN	c/h <sup>2)</sup>			
<b>1500 r/min = 4 poles</b>			<b>400 V 50 Hz</b>						<b>Basic design</b>							
0.12	M3VRF 63 A	3GVR 062 401-...C	1400	0.82	7.5	2.6	9.37	63.7	58.4	0.59	0.46	3.1	7100	0.00029	5	
0.12	M3VRF 63 MA	3GVR 062 411-...C	1365	0.84	4.5	2.0	5.4	54.0	52.0	0.66	0.49	2.8	7100	0.00026	5	
0.18	M3VRF 63 B	3GVR 062 402-...C	1380	1.25	7.5	2.5	5.76	65.6	62.1	0.64	0.63	3.1	7100	0.00036	5.5	
0.18	M3VRF 63 MB	3GVR 062 412-...C	1380	1.25	4.5	2.2	3.6	61.0	57.0	0.63	0.68	3.2	7100	0.00033	5	
0.25	M3VRF 71 A	3GVR 072 401-...E	1410	1.71	10	2.7	5.88	70.4	69.1	0.71	0.74	4.3	6500	0.00081	7	
0.37	M3VRF 71 B	3GVR 072 402-...E	1420	2.51	10	2.6	4	74.6	72.1	0.69	1.05	4.4	6500	0.00104	8	
0.55	M3VRF 80 A	3GVR 082 401-...E	1390	3.75	24	2.6	6.31	75.3	73.1	0.76	1.4	4.6	5000	0.00128	11	
0.75	M3VRF 80 B	3GVR 082 402-...E	1410	5.08	24	3.5	4.7	78.2	75.6	0.74	1.9	4.7	5000	0.00159	12	
1.1	M3ARF 90 S	3GAR 092 401-...E	1410	7.5	35	2.2	4.66	77.5	76.4	0.81	2.59	5.0	3200	0.0034	19	
1.5	M3ARF 90 L	3GAR 092 402-...E	1420	10	35	2.4	3.5	80.3	78.1	0.79	3.45	5.0	3200	0.0045	22	
2.2	M3ARF 100 LA	3GAR 102 401-...E	1430	15	44	2.4	2.93	83.0	82.7	0.81	4.8	5.5	2700	0.00733	32	
3	M3ARF 100 LB	3GAR 102 402-...E	1430	20	44	2.5	2.2	85.0	83.9	0.81	6.48	5.5	2700	0.00863	35	
4	M3ARF 112 M	3GAR 112 401-...E	1435	26.6	86	2.9	3.23	84.5	83.9	0.80	8.6	7.0	2500	0.01578	40	
5.5	M3ARF 132 S	3GAR 132 401-...E	1450	36.2	130	2.2	3.59	87.0	87.7	0.83	11.1	7.3	1800	0.03357	60	
7.5	M3ARF 132 M	3GAR 132 402-...E	1450	49.4	130	2.5	2.63	88.0	88.6	0.83	14.8	7.9	1400	0.04057	68	
11	M3ARF 160 M	3GAR 162 411-...E	1465	72	230	2.4	3.2	88.4	88.8	0.78	22.5	6.9	500	0.07696	117	
15	M3ARF 160 L	3GAR 162 412-...E	1460	98	230	2.8	2.3	90.0	90.5	0.82	29	7.2	500	0.08796	129	
18.5	M3ARF 180 M	3GAR 182 411-...E	1455	121	230	2.6	1.9	90.4	90.4	0.84	35	7.0	360	0.10464	161	
22	M3ARF 180 L	3GAR 182 412-...E	1460	144	230	3.0	1.6	91.1	91.5	0.82	42	8.0	360	0.12964	175	

<b>1500 r/min = 4 poles</b>			<b>400 V 50 Hz</b>						<b>High-output design</b>							
0.25	M3VRF 63 BB	3GVR 062 403-...C	1370	1.75	7.5	2.5	4.16	70.3	67.4	0.67	0.78	3.2	7100	0.0004	6	
0.45	M3VRF 71 BB	3GVR 072 403-...E	1390	3.11	10	2.1	3.22	75.5	75.3	0.76	1.15	4.1	6500	0.00104	8	
0.55	M3VRF 71 C	3GVR 072 404-...E	1410	3.74	10	2.7	2.7	77.3	76.9	0.73	1.45	4.8	6500	0.00125	9	
0.95	M3VRF 80 C	3GVR 082 403-...E	1410	6.44	24	2.9	3.75	78.9	77.9	0.75	2.35	4.3	500	0.00197	13	
1.85 <sup>3)</sup>	M3ARF 90 L	3GAR 092 403-...E	1390	13	35	2.2	2.69	79.5	78.1	0.80	4.4	4.5	3200	0.0045	22	
2.2 <sup>3)</sup>	M3ARF 90 LB	3GAR 092 404-...E	1390	15	35	2.2	2.33	80.3	81.0	0.83	4.85	4.5	3200	0.0048	23	
4 <sup>3)</sup>	M3ARF 100 LC	3GAR 102 403-...E	1420	27	44	2.5	1.62	81.0	81.7	0.82	8.65	5.5	2700	0.009	36	
5.5 <sup>3)</sup>	M3ARF 112 MB	3GAR 112 402-...E	1425	36.9	86	2.8	2.33	84.5	83.5	0.83	11.4	7.1	2500	0.018	47	
9.2 <sup>3)</sup>	M3ARF 132 MBA	3GAR 132 404-...E	1450	60	130	2.0	2.14	88.0	88.6	0.85	17.8	7.3	1400	0.05	83	
11 <sup>3)</sup>	M3ARF 132 MB	3GAR 132 403-...E	1450	72	130	2.5	1.79	88.0	89.4	0.86	21	8.3	500	0.05	83	
18.5 <sup>3)</sup>	M3ARF 160 LB	3GAR 162 403-...E	1450	122	230	2.9	1.88	90.5	88.9	0.84	36	6.9	500	0.107	143	

<sup>1)</sup> Braking-torque ratio

<sup>2)</sup> No-load (shaft-free) operations/hour

<sup>3)</sup> Temperature rise class F.

The bullets in the product code indicate choice of mounting arrangement and voltage and frequency code, see below and ordering information page.

### Code letters for supplementing product code for mounting arrangement:

Foot-mounted **A**  
 Flange-mounted, 1 flange **B** for frame sizes 63-100, 180; **E** for frame sizes 112-160.  
 Flange-mounted, 2 flanges **N** for frame sizes 90-132  
 Flange-mounted, small flange **C** for frame sizes 63-100

### Code letters for supplementing product code for voltage and frequency (pos 13):

Motor size	S Motor			Brake (input rectifier voltage/brake voltage)	D Motor			X
	50 Hz	60 Hz			50 Hz	60 Hz		
63-132	220-240 VΔ 380-420 VY	250-280 VΔ		220-240 V/205 V d.c.	380-420 VΔ 660-690 VY	440-480 VΔ –	380-420 V/178 V d.c.	Any other rated voltage or frequency, 690 V maximum connection for motor and 500 V for brake (input rectifier)
160-180	230 VΔ 400 VY	265 VΔ		230 V/205 V d.c.	400 VΔ 690 VY	460 VΔ –	400 V/178 V d.c.	
Motor size	E Motor			Brake (input rectifier voltage/brake voltage)	F Motor			X
	50 Hz				50 Hz			
63-80	–			–	500 VY		500 V/223 V d.c.	
90-180	500 VΔ			500 V/223 V d.c.	500 VY		500 V/223 V d.c.	

# General purpose brake motors

## Technical data for single-speed DC brake motors

IP 55 – IC 411 – Insulation class F, temperature rise class B – Brake IP 23 S

Output Motor kW type	Product code	Torque						Efficiency		Power factor cos φ	Current			Moment of inertia J=1/4GD <sup>2</sup> kgm <sup>2</sup>	Weight Foot mounted kg	
		Speed r/min	TN Nm	braking TB Nm	TS/ TN	K <sup>1)</sup>	100%	75%	IN A		IS/IN	c/h <sup>2)</sup>				
<b>1000 r/min = 6 poles</b>		<b>400 V 50 Hz</b>						<b>Basic design</b>								
0.09	M3VRF 63 A	3GVR 063 401-••C	910	0.95	7.5	2.1	7.89	47.1	42.5	0.56	0.51	2.1	7700	0.0003	5	
0.12	M3VRF 63 B	3GVR 063 402-••C	860	1.27	7.5	1.8	5.9	56.0	53.5	0.55	0.56	2.4	7700	0.00037	5.5	
0.12	M3VRF 63 MB	3GVR 063 412-••C	860	1.27	4.5	1.8	3.5	56.0	50.0	0.55	0.56	2.4	7700	0.00033	5	
0.18	M3VRF 71 A	3GVR 073 401-••E	920	1.88	10	2.1	5.31	61.1	57.7	0.69	0.64	2.9	7500	0.00078	7	
0.25	M3VRF 71 B	3GVR 073 402-••E	920	2.61	10	2.5	3.84	64.9	62.3	0.65	0.86	3.2	7500	0.00096	8	
0.37	M3VRF 80 A	3GVR 083 401-••E	925	3.82	24	3.1	6.28	72.9	70.8	0.72	1.04	3.8	7000	0.00186	11	
0.55	M3VRF 80 B	3GVR 083 402-••E	925	5.68	24	2.9	4.22	73.3	71.9	0.71	1.55	3.4	7000	0.0022	12	
0.75	M3ARF 90 S	3GAR 093 401-••E	930	7.5	35	1.9	4.66	71.5	70.7	0.67	2.36	4.0	3800	0.0034	19	
1.1	M3ARF 90 L	3GAR 093 402-••E	930	11	35	2.1	3.18	74.4	72.5	0.69	3.25	4.0	3900	0.0045	22	
1.5	M3ARF 100 L	3GAR 103 401-••E	950	15	44	1.9	2.93	80.0	77.0	0.71	3.92	4.5	3300	0.0086	34	
2.2	M3ARF 112 M	3GAR 113 401-••E	940	22.3	86	2.1	3.85	80.5	79.3	0.74	5.4	5.6	3200	0.015	40	
3	M3ARF 132 S	3GAR 133 401-••E	960	29.8	130	2.0	4.36	84.5	82.7	0.75	6.9	6.1	2400	0.033	59	
4	M3ARF 132 MA	3GAR 133 402-••E	960	39.7	130	2.0	3.27	85.5	83.1	0.78	8.7	7.1	1900	0.04	66	
5.5	M3ARF 132 MB	3GAR 133 403-••E	955	55	130	2.2	2.36	86.0	85.0	0.78	11.9	6.9	1900	0.047	74	
7.5	M3ARF 160 M	3GAR 163 401-••E	970	74	230	2.0	3.14	89.3	88.4	0.79	15.4	6.7	600	0.087	129	
11	M3ARF 160 L	3GAR 163 402-••E	970	109	230	2.2	2.13	89.8	88.5	0.78	23	7.1	600	0.127	149	
<b>1000 r/min = 6 poles</b>		<b>400 V 50 Hz</b>						<b>High-output design</b>								
0.15	M3VRF 63 BB	3GVR 063 403-••C	900	1.61	7.5	2.2	4.68	56.9	52.1	0.54	0.74	2.2	7700	0.00042	6	
0.32	M3VRF 71 C	3GVR 073 403-••E	920	3.33	10	2.6	3.1	64.8	61.6	0.63	1.15	3.2	7500	0.00125	9	
1.3	<sup>3)</sup> M3ARF 90 LB	3GAR 093 403-••E	910	13.5	35	1.9	2.59	69.0	69.0	0.71	3.85	4.0	3800	0.005	24	
2.2	<sup>3)</sup> M3ARF 100 LC	3GAR 103 402-••E	940	22	44	1.9	2.0	77.0	72.8	0.71	5.9	4.5	3300	0.009	37	
3	<sup>3)</sup> M3ARF 112 MB	3GAR 113 402-••E	935	30.6	86	2.0	2.81	80.0	79.9	0.76	7.2	5.5	3200	0.018	46	
6.5	<sup>3)</sup> M3ARF 132 MC	3GAR 133 404-••E	960	64	130	2.0	2.01	85.0	84.5	0.75	14.8	6.6	2400	0.051	79	
14	<sup>3)</sup> M3ARF 160 LB	3GAR 163 403-••E	960	139	230	2.7	1.65	89.1	84.5	0.77	29.5	7.6	1900	0.147	164	

<sup>1)</sup> Braking-torque ratio

<sup>2)</sup> No-load (shaft-free) operations/hour

<sup>3)</sup> Temperature rise class F.

The bullets in the product code indicate choice of mounting arrangement and voltage and frequency code, see below and ordering information page.

### Code letters for supplementing product code for mounting arrangement:

Foot-mounted **A**  
 Flange-mounted, 1 flange **B** for frame sizes 63-100, 180; **E** for frame sizes 112-160.  
 Flange-mounted, 2 flanges **N** for frame sizes 90-132  
 Flange-mounted, small flange **C** for frame sizes 63-100

### Code letters for supplementing product code for voltage and frequency (pos 13):

Motor size	<b>S</b> Motor			<b>D</b> Motor			<b>X</b>
	50 Hz	60 Hz	Brake (input rectifier voltage/brake voltage)	50 Hz	60 Hz	Brake (input rectifier voltage/brake voltage)	
<b>63-132</b>	220-240 VΔ 380-420 VY	250-280 VΔ	220-240 V/205 V d.c.	380-420 VΔ 660-690 VY	440-480 VΔ	380-420 V/178 V d.c.	Any other rated voltage or frequency, 690 V maximum connection for motor and 500 V for brake (input rectifier)
<b>160-180</b>	230 VΔ 400 VY	265 VΔ	230 V/205 V d.c.	400 VΔ 690 VY	460 VΔ	400 V/178 V d.c.	
Motor size	<b>E</b> Motor			<b>F</b> Motor			
	50 Hz		Brake (input rectifier voltage/brake voltage)	50 Hz		Brake (input rectifier voltage/brake voltage)	
<b>63-80</b>	–	–	–	500 VY	–	500 V/223 V d.c.	
<b>90-180</b>	500 VΔ	–	500 V/223 V d.c.	500 VY	–	500 V/223 V d.c.	



# General purpose brake motors

## Technical data for single-speed DC brake motors

IP 55 – IC 411 – Insulation class F, temperature rise class B – Brake IP 23 S

Output kW	Motor type	Product code	Speed r/min	Torque				Efficiency		Power factor cos φ	Current			Moment of inertia J=1/4GD <sup>2</sup> kgm <sup>2</sup>	Weight Foot mounted kg
				rated TN Nm	braking TB Nm	TS/ TN	K <sup>1)</sup>	100%	75%		IN A	IS/IN	c/h <sup>2)</sup>		
<b>750 r/min = 8 poles</b>			<b>400 V 50 Hz</b>			<b>Basic design</b>									
0.055	M3VRF 63 B	3GVR 064 401-...C	680	0.78	7.5	2.1	9.4	38.3	31.8	0.48	0.45	1.8	7700	0.00037	5.5
0.09	M3VRF 71 A	3GVR 074 401-...E	690	1.25	10	2.3	7.69	45.8	37.5	0.57	0.52	2.2	7500	0.00078	7
0.12	M3VRF 71 B	3GVR 074 402-...E	690	1.67	10	2.5	5.88	46.4	38.1	0.55	0.69	2.2	7500	0.00096	8
0.18	M3VRF 80 A	3GVR 084 401-...E	700	2.46	24	3.2	9.6	59.9	54.5	0.60	0.75	3.1	7500	0.0022	11
0.25	M3VRF 80 B	3GVR 084 402-...E	700	3.52	24	2.9	6.85	70.7	67.4	0.62	0.85	3.1	7500	0.00245	12
0.37	M3ARF 90 S	3GAR 094 401-...E	700	5	35	1.9	7.0	61.5	43.4	0.56	1.6	3.0	4100	0.0032	19
0.55	M3ARF 90 L	3GAR 094 402-...E	690	7.5	35	1.7	4.66	62.9	56.4	0.57	2.35	3.0	4100	0.0045	22
0.75	M3ARF 100 LA	3GAR 104 401-...E	700	10	44	2.1	4.4	72.0	63.6	0.59	2.55	3.5	3600	0.0073	31
1.1	M3ARF 100 LB	3GAR 104 402-...E	700	15	44	2.1	2.93	73.0	68.8	0.64	3.35	3.5	3700	0.0086	34
1.5	M3ARF 112 M	3GAR 114 401-...E	695	20.6	86	1.9	4.17	74.5	75.9	0.65	4.5	4.1	3600	0.016	41
2.2	M3ARF 132 S	3GAR 134 401-...E	720	29.2	130	1.6	4.45	80.5	77.8	0.67	5.9	5.3	3000	0.04	66
3	M3ARF 132 M	3GAR 134 402-...E	720	39.8	130	1.8	3.26	82.0	79.2	0.68	7.8	5.5	2600	0.047	73
4	M3ARF 160 MA	3GAR 164 401-...E	715	54	230	2.1	4.39	84.1	81.1	0.69	10	5.2	600	0.11	139
5.5	M3ARF 160 M	3GAR 164 402-...E	710	74	230	2.4	3.17	84.7	75.0	0.70	13.4	5.4	600	0.11	139
7.5	M3ARF 160 L	3GAR 164 403-...E	715	100	230	2.4	2.31	86.3	82.4	0.70	18.1	5.4	600	0.127	154

<sup>1)</sup> Braking-torque ratio

<sup>2)</sup> No-load (shaft-free) operations/hour

<sup>3)</sup> Temperature rise class F.

The bullets in the product code indicate choice of mounting arrangement and voltage and frequency code, see below and ordering information page.

### Code letters for supplementing product code for mounting arrangement:

Foot-mounted **A**  
 Flange-mounted, 1 flange **B** for frame sizes 63-100, 180; **E** for frame sizes 112-160.  
 Flange-mounted, 2 flanges **N** for frame sizes 90-132  
 Flange-mounted, small flange **C** for frame sizes 63-100

### Code letters for supplementing product code for voltage and frequency (pos 13):

Motor size	<b>S</b> Motor			<b>D</b> Motor			<b>X</b>
	50 Hz	60 Hz	Brake (input rectifier voltage/brake voltage)	50 Hz	60 Hz	Brake (input rectifier voltage/brake voltage)	
<b>63-132</b>	220-240 VΔ 380-420 VY	250-280 VΔ	220-240 V/205 V d.c.	380-420 VΔ 660-690 VY	440-480 VΔ –	380-420 V/178 V d.c.	Any other rated voltage or frequency, 690 V mimum connection for motor and 500 V for brake (input rectifier)
<b>160-180</b>	230 VΔ 400 VY	265 VΔ	230 V/205 V d.c.	400 VΔ 690 VY	460 VΔ –	400 V/178 V d.c.	
Motor size	<b>E</b> Motor			<b>F</b> Motor			
	50 Hz		Brake (input rectifier voltage/brake voltage)	50 Hz		Brake (input rectifier voltage/brake voltage)	
<b>63-80</b>	–		–	500 VY		500 V/223 V d.c.	
<b>90-180</b>	500 VΔ		500 V/223 V d.c.	500 VY		500 V/223 V d.c.	

# General purpose brake motors

## Technical data for two-speed DC brake motors

IP 55 – IC 411 – Insulation class F, temperature rise class F – Brake IP 23 S

Output kW	Motor type	Product code	Speed r/min	Torque			Efficiency %	Power factor cos φ	Current		Moment of inertia J=1/4GD <sup>2</sup> kgm <sup>2</sup>	Weight IM 1001 kg	
				rated TN Nm	braking TB Nm	TS/TN K <sup>1)</sup>			IN	IS/IN A			
<b>3000/1500 r/min = 2/4 poles</b>				<b>400 V 50 Hz</b>				<b>Constant torque, two separate windings</b>					
1.1/0.55	M3ARF 90 S	3GAR 098 401-EE	2900/1450	3.6/3.6	35	1.4/1.5	9.7/9.7	74/62	0.85/0.64	2.5/2	5.1/3.6	0.0019	20
1.5/0.75	M3ARF 90 L	3GAR 098 402-EE	2900/1450	4.9/4.9	35	1.5/1.5	7.1/7.1	77/70	0.87/0.67	3.3/2.4	5.7/4.1	0.0024	23
2.0/1.0	M3ARF 100 L	3GAR 108 401-EE	2900/1460	6.5/6.5	44	1.9/1.4	7.7/7.7	76/67	0.89/0.66	4.3/3.3	6.2/4	0.0041	32
2.6/1.3	M3ARF 112 M	3GAR 118 401-EE	2900/1460	8.6/8.5	86	1.6/1.6	10/9.9	80/75	0.92/0.72	5.1/3.5	6.4/5	0.012	45
4.4/2.2	M3ARF 132 SB	3GAR 138 401-EE	2925/1450	14.4/14.5	130	2/1.3	10.4/10	81/74	0.86/0.73	9.1/5.9	7.3/4.5	0.016	55
5.6/2.8	M3ARF 132 M	3GAR 138 402-EE	2885/1440	18.5/18.6	130	1.8/1.4	8.1/8.1	82/77	0.93/0.75	10.6/7	6.7/5	0.022	76
<b>3000/1500 r/min = 2-4 poles</b>				<b>400 V 50 Hz</b>				<b>Constant torque, Dahlander connection</b>					
0.2/0.15	M3VRF 63 A	3GVR 068 401-CC	2800/1400	0.68/1.02	7.5	2.1/2	11/7.4	63/54	0.7/0.63	0.65/0.65	3.6/2.8	0.00019	5
0.3/0.2	M3VRF 63 B	3GVR 068 402-CC	2740/1370	1.05/1.4	7.5	1.7/2.1	7.1/5.4	59/55	0.78/0.63	0.95/0.85	2.8/2.8	0.00026	5.5
0.37/0.25	M3VRF 71 A	3GVR 078 401-EE	2700/1390	1.3/1.72	10	1.9/1.5	9.2/7	64/60	0.89/0.79	0.95/0.7	3.3/3.1	0.00066	7
0.48/0.31	M3VRF 71 B	3GVR 078 402-EE	2780/1400	1.66/2.15	10	1.4/2	7.1/5.6	68/68	0.91/0.76	1.2/0.9	3.6/4	0.00089	8
0.55/0.37	M3VRF 71 C	3GVR 078 403-EE	2800/1400	1.87/2.52	10	1.8/1.9	6.4/4.8	66/64	0.8/0.65	1.5/1.2	4.7/4.3	0.0011	8.5
0.63/0.5	M3VRF 80 A	3GVR 088 401-EE	2690/1400	2.25/3.42	24	1.8/1.9	7.6/5.5	66/67	0.87/0.79	1.6/1.35	3.6/4.2	0.0013	11
0.85/0.65	M3VRF 80 B	3GVR 088 402-EE	2725/1405	2.99/4.43	24	1.9/2	5.4/3.6	70/70	0.88/0.8	2/1.7	4/4.4	0.0016	12.5
1.1/0.8	M3VRF 80 C	3GVR 088 403-EE	2730/1410	3.8/5.38	24	2/2	4.7/3.3	72/71	0.88/0.79	2.55/2.05	4.2/4.7	0.002	13
1.3/1	M3ARF 90 S	3GAR 098 403-EE	2730/1400	4.5/6.8	35	2/1.5	7.8/5.1	71/71	0.88/0.8	3.1/2.6	3.9/3.8	0.0032	20
1.9/1.5	M3ARF 90 L	3GAR 098 404-EE	2820/1420	6.4/10	35	2.8/2	5.5/3.5	74/75	0.82/0.76	4.4/3.9	5.1/4.4	0.0043	23
2.5/2.1	M3ARF 100 LA	3GAR 108 402-EE	2800/1430	8.5/14	44	2.2/1.6	5.9/3.6	68/76	0.88/0.81	6/5	4.8/4.4	0.0069	32
3.4/2.5	M3ARF 100 LB	3GAR 108 403-EE	2810/1430	11.5/18	44	2.2/1.9	4.3/2.7	78/80	0.88/0.85	7.2/5.9	5.3/5.4	0.0082	35
4/2.6	M3ARF 112 M	3GAR 118 402-EE	2865/1430	13.3/17.4	86	1.8/2.3	10/9.9	82/77	0.93/0.76	7.6/6.5	6.3/6.2	0.012	45
6.3/4.4	M3ARF 132 SA	3GAR 138 411-EE	2895/1445	20.8/29	130	1.7/1.6	7.2/5.2	85/84	0.94/0.8	11.4/9.5	6.5/5.7	0.0155	58
4.7/3.1	M3ARF 132 SB	3GAR 138 403-EE	2820/1420	15.9/20.8	130	1.8/2.2	10.4/10	79/77	0.92/0.76	9.2/7.7	5.5/5.7	0.016	55
8/6.2	M3ARF 132 SC	3GAR 138 412-EE	2910/1440	26.2/41.1	130	1.9/1.6	6.9/3.6	87/85	0.95/0.83	14/12.7	7.8/5.6	0.0215	78
7.2/4.8	M3ARF 132 M	3GAR 138 404-EE	2870/1435	24/31.9	130	2.4/2.5	6.3/4.7	84/81	0.92/0.76	13.3/11.5	7.1/6.2	0.022	76
9.6/7	M3ARF 132 MD	3GAR 138 413-EE	2900/1440	31.6/46.4	130	1.8/1.7	4.7/3.2	87/85	0.95/0.85	16.8/14.1	7.6/5.9	0.026	85
12.5/9	M3ARF 160 M	3GAR 168 404-EE	2890/1440	41/60	230	1.4/1.8	5.6/3.8	85.5/85.5	0.93/0.8	22.5/19	5.2/4.6	0.054	129
15/10.5	M3ARF 160 L	3GAR 168 405-EE	2900/1445	49/69	230	1.6/2.1	4.7/3.3	87/86	0.93/0.77	27/23	5.8/4.9	0.057	139
<b>1500/1000 r/min = 4/6 poles</b>				<b>400 V 50 Hz</b>				<b>Constant torque, two separate windings</b>					
0.11/0.08	M3VRF 63 B	3GVR 068 403-CC	1390/860	0.75/0.88	7.5	1.4/1.8	10/8.5	40/25	0.7/0.72	0.55/0.62	2.5/1.8	0.00026	5.5
0.3/0.2	M3VRF 71 A	3GVR 078 404-EE	1390/900	1.37/0.79	10	1.1/1.05	15.2/8.8	51/40	0.82/0.72	0.7/0.5	2.8/2	0.00066	7
0.37/0.22	M3VRF 71 B	3GVR 078 405-EE	1380/900	2.07/1.91	10	1/1.1	6.3/5.8	58/40	0.83/0.8	0.9/0.8	2.7/1.9	0.00089	8
0.43/0.28	M3VRF 80 A	3GVR 088 404-EE	1380/910	2.54/3.02	24	1.5/1.4	7.1/6	60/54	0.85/0.81	1.4/1.2	3.1/2.9	0.0019	12
0.58/0.37	M3VRF 80 B	3GVR 088 405-EE	1390/920	4/3.85	24	1.5/1.5	4/3.5	63/58	0.85/0.8	1.6/1.15	3.3/3.2	0.0022	12.5
0.8/0.5	M3ARF 90 S	3GAR 098 405-EE	1430/940	5.3/5	35	1.5/1.4	7/6.6	68/57	0.8/0.66	2.2/2	3.9/2.8	0.0032	20
1.2/0.75	M3ARF 90 L	3GAR 098 406-EE	1430/940	8/7.6	35	1.7/1.5	4.6/4.4	73/63	0.81/0.67	3/2.6	4.4/3.1	0.0043	23
1.5/0.9	M3ARF 100 LA	3GAR 108 404-EE	1440/960	9.9/8.9	44	1.5/1.5	5.6/5.1	75/69	0.84/0.65	3.5/3	4.7/3.8	0.0069	32
1.8/1.1	M3ARF 100 LB	3GAR 108 405-EE	1460/960	11/11	44	2.1/1.6	4.5/4.5	77/70	0.78/0.64	4.4/3.6	5.8/3.9	0.0082	35
2.6/1.7	M3ARF 112 M	3GAR 118 403-EE	1445/960	17.2/16.9	86	1.5/1.5	5/4.9	80/70	0.85/0.76	5.5/4.4	5.9/5.2	0.018	45
3.3/2.2	M3ARF 132 S	3GAR 138 405-EE	1470/980	21.4/21.4	130	1.4/1.2	7/7	82/76	0.8/0.65	7.1/6.4	6.8/4.6	0.038	61
4.5/3	M3ARF 132 M	3GAR 138 406-EE	1470/980	29.2/29.2	130	1.4/1.5	5.1/5.1	82/77	0.81/0.7	9.8/8	7.2/5.6	0.048	79
5.5/3.7	M3ARF 132 MD	3GAR 138 414-EE	1460/960	36/36.8	130	1.9/1.8	4.2/4.2	85/81	0.88/0.8	10.7/8.3	8/6.3	0.036	84
7.5/5.5	M3ARF 160 M	3GAR 168 406-EE	1465/965	49/54	230	2.1/1.8	3.1/2.7	85.5/80.5	0.83/0.77	15.5/13	7.1/4.7	0.089	129
11.5/8.5	M3ARF 160 L	3GAR 168 407-EE	1465/965	75/84	230	2.1/1.8	2.9/2.7	86.5/82.5	0.84/0.76	23/19.5	7/4.9	0.119	139

<sup>1)</sup> Braking-torque ratio

# General purpose brake motors

## Technical data for two-speed DC brake motors

IP 55 – IC 411 – Insulation class F, temperature rise class F – Brake IP 23 S

Output kW	Motor type	Product code	Speed r/min	Torque				Efficiency %	Power factor cos φ	Current		Moment of inertia J=1/4GD <sup>2</sup> kgm <sup>2</sup>	Weight IM 1001 kg
				rated TN Nm	braking TB Nm	TS/TN K <sup>1)</sup>	K <sup>1)</sup>			IN	IS/IN A		
<b>3000/750 r/min = 2/8 poles</b>			<b>400 V 50 Hz</b>				<b>Constant torque, two separate windings</b>						
0.25/0.06	M3VRF 71 A	3GVR 078 408-***E	2760/660	0.86/0.86	10	1/1.3	14/14	52/36	0.94/0.7	0.75/0.35	2.9/1.9	0.00066	7
0.37/0.09	M3VRF 71 B	3GVR 078 409-***E	2800/660	1.26/1.3	10	1/1.6	9.5/9.2	68/41	0.87/0.65	0.9/0.5	2.8/2	0.00089	8
0.5/0.12	M3VRF 80 A	3GVR 088 409-***E	2730/700	1.78/1.64	24	1.3/2	10.9/9.6	60/38	0.87/0.58	1.4/0.8	3.2/2.3	0.0013	12.5
0.66/0.15	M3VRF 80 B	3GVR 088 410-***E	2780/700	2.55/2.45	24	1.4/2.2	7.3/7.1	65/40	0.87/0.58	1.65/0.95	3.8/2.5	0.0016	13
0.75/0.18	M3ARF 90 LA	3GAR 098 411-***E	2875/720	2.5/2.4	35	2.3/1.3	14/14	71.2/46.3	0.8/0.51	1.9/1.1	5.7/2.4	0.0043	23
1.3/0.33	M3ARF 90 LB	3GAR 098 412-***E	2780/690	4.4/4.5	35	1.8/1.2	8/8	71/52	0.92/0.62	2.9/1.5	4.5/2.3	0.0043	23
1.8/0.5	M3ARF 100 LB	3GAR 108 410-***E	2860/705	6.6/2.007	44	1.7/1.3	8.3/7.4	80/54	0.93/0.64	3.5/2.1	5.3/2.6	0.0082	35
2.2/0.59	M3ARF 112 MC	3GAR 118 406-***E	2900/720	7.2/7.8	86	2.4/1.6	11.8/11	78/62	0.87/0.55	4.9/2.5	7/3.5	0.015	42
3.3/0.95	M3ARF 132 SA	3GAR 138 415-***E	2940/730	10.7/12.4	130	2.6/1.2	14/12	81/72	0.95/0.52	6.2/3.7	9.5/4.3	0.0215	65
4.4/1.3	M3ARF 132 MC	3GAR 138 416-***E	2920/725	14.4/17.1	130	2.2/1.3	10.7/8.8	82/74	0.94/0.62	8.3/4.1	8.6/4	0.03	77
<b>1500/750 r/min = 4/8 poles</b>			<b>400 V 50 Hz</b>				<b>Constant torque, two separate windings</b>						
0.55/0.25	M3ARF 90 S	3GAR 098 407-***E	1450/700	3.6/3.4	35	1.3/1.4	10.3/9.7	62/51	0.78/0.59	1.9/1.2	4.2/2.3	0.0032	20
0.75/0.37	M3ARF 90 L	3GAR 098 408-***E	1450/700	4.9/5	35	1.4/1.5	7.1/7	66/57	0.75/0.57	2.2/1.7	4.1/2.5	0.0043	23
1.1/0.55	M3ARF 100 LA	3GAR 108 406-***E	1460/710	7.2/7.4	44	1.2/1.2	6.9/6.8	68/62	0.77/0.61	3.1/2.2	4.2/2.6	0.0069	32
1.5/0.75	M3ARF 100 LB	3GAR 108 407-***E	1440/700	9.8/10	44	1.3/1.2	5.1/5	72/60	0.82/0.6	3.7/2.9	4.6/2.7	0.0082	35
1.8/0.9	M3ARF 112 M	3GAR 118 404-***E	1460/715	11.7/12	86	1.2/1.6	7.3/7.1	77/65	0.76/0.66	4.4/3	6.5/4	0.018	45
2.5/1.3	M3ARF 132 S	3GAR 138 407-***E	1480/735	16.2/17	130	1.6/1.4	9.3/8.8	80/67	0.79/0.56	5.8/6	6/3.7	0.038	61
3.3/1.7	M3ARF 132 M	3GAR 138 408-***E	1470/725	21.4/22.4	130	1.6/1.4	7/6.7	81/71	0.79/0.58	7.5/6	7/4.2	0.048	79
<b>1500/750 r/min = 4-8 poles</b>			<b>400 V 50 Hz</b>				<b>Constant torque, Dahlander connection</b>						
0.11/0.06	M3VRF 63 B	3GVR 068 404-***C	1390/660	0.75/0.87	7.5	1.6/2.5	10/8.6	54/33	0.6/0.49	0.5/0.55	3/1.7	0.0026	5.5
0.18/0.11	M3VRF 71 A	3GVR 078 406-***E	1380/680	1.24/1.54	10	1.9/2.2	9.7/7.8	54/37	0.7/0.53	0.7/0.8	3.2/2.5	0.0066	7
0.3/0.15	M3VRF 71 B	3GVR 078 407-***E	1400/700	2.05/2.05	10	2/2.5	5.9/5.9	60/47	0.74/0.51	0.9/0.9	3.2/2.6	0.00089	8
0.45/0.25	M3VRF 80 A	3GVR 088 406-***E	1380/700	3.12/3.42	24	1.7/2.1	6.5/6	65/48	0.87/0.58	1.15/1.3	3.5/2.7	0.0019	11
0.63/0.33	M3VRF 80 B	3GVR 088 407-***E	1380/705	4.37/4.48	24	1.7/2.2	4/3.9	67/50	0.88/0.56	1.55/1.7	3.5/2.8	0.0022	12
0.75/0.37	M3VRF 80 C	3GVR 088 408-***E	1390/710	5.16/4.98	24	1.9/2.5	3.6/3.5	70/52	0.86/0.51	1.8/2	3.9/2.9	0.0025	12.5
0.7/0.37	M3ARF 90 S	3GAR 098 409-***E	1420/700	4.7/5.1	35	1.6/1.6	7.4/6.9	72/50	0.8/0.57	1.8/1.9	4.4/2.3	0.0032	20
1.1/0.55	M3ARF 90 L	3GAR 098 410-***E	1390/685	7.4/7.5	35	1.4/1.5	4.7/4.7	70/55	0.84/0.58	2.6/2.6	4.1/2.3	0.0043	23
1.5/0.75	M3ARF 100 LA	3GAR 108 408-***E	1440/710	10/10	44	1.4/1.5	5/5	76/62	0.85/0.57	3.4/3.2	4.6/2.8	0.0069	32
2/0.95	M3ARF 100 LB	3GAR 108 409-***E	1440/710	13/12	44	1.4/1.6	4.2/3.8	78/64	0.86/0.55	4.4/4	4.8/2.9	0.0082	35
2.5/1.5	M3ARF 112 M	3GAR 118 405-***E	1410/705	16.9/20.3	86	1.4/1.5	5/4.2	78/67	0.9/0.66	5.1/4.9	5.5/4.1	0.018	45
3.8/1.9	M3ARF 132 S	3GAR 138 409-***E	1450/730	25/24.9	130	1.4/1.3	6/6	82/70	0.84/0.52	7.7/7.6	5.6/3.7	0.038	61
5/2.5	M3ARF 132 M	3GAR 138 410-***E	1455/730	32.8/32.7	130	1.7/2	4.6/4.6	85/73	0.88/0.52	9.6/9.6	6.9/4.8	0.048	79
8/4.5	M3ARF 160 M	3GAR 168 410-***E	1440/730	53/59	230	1.3/1.4	4.3/3.9	84.5/79.5	0.86/0.6	16/13.5	4.5/3.4	0.089	129
12/7	M3ARF 160 L	3GAR 168 411-***E	1445/730	79/92	230	1.5/1.4	2.9/2.5	86.5/81	0.87/0.59	23/21	5/3.5	0.119	139

<sup>1)</sup> Braking-torque ratio

The bullets in the product code indicate choice of mounting arrangement and voltage and frequency code, see below and ordering information page.

Code letters for supplementing product code for mounting arrangement (pos 12):

Foot-mounted **A**  
 Flange-mounted, 1 flange **B** for frame sizes 63-100, 180; **E** for frame sizes 112-160.  
 Flange-mounted, 2 flanges **N** for frame sizes 90-132  
 Flange-mounted, small flange **C** for frame sizes 63-100

Code letters for supplementing product code for voltage and frequency (pos 13):

Motor size	<b>A</b>		<b>B</b>		<b>S</b>	
	Motor	Brake (input rectifier voltage/brake voltage)	Motor	Brake (input rectifier voltage/brake voltage)	Motor	Brake (input rectifier voltage/brake voltage)
63-132	–	–	–	–	220-230 V	220-230 V/205 V d.c.
160	220 V	220 V/205 V d.c.	380 V	380 V/178 V d.c.	230 V	230 V/205 V d.c.
Motor size	<b>D</b>		<b>E</b>		<b>X</b>	
	Motor	Brake (input rectifier voltage/brake voltage)	Motor	Brake (input rectifier voltage/brake voltage)	Any other rated voltage or frequency, 690 V maximum connection for motor and 500 V for brake (input rectifier)	
63-132	380-400 V	380-400 V/178 V d.c.	500 V	500 V/223 V d.c.		
160	400 V	400 V/178 V d.c.	500 V	500 V/223 V d.c.–		

# General purpose brake motors

## Technical data for single-speed motors with three phase AC brake

IP 55 – IC 411 – Insulation class F, temperature rise class B – Brake IP 23 S

Output Motor kW type	Product code	Speed r/min	Torque				Efficiency		Power factor cos φ	Current			Moment of inertia J=1/4GD <sup>2</sup> kgm <sup>2</sup>	Weight Foot mounted kg	
			TN Nm	braking TB Nm	TS/ TN	K <sup>1)</sup>	100%	75%		IN A	IS/IN	c/h <sup>2)</sup>			
<b>3000 r/min = 2 poles</b>		<b>400 V 50 Hz</b>				<b>Basic design</b>									
0.18	M3VRS 63 A	3GVR 061 451-••C	2820	0.62	7.5	3.5	12.5	73.7	70.6	0.64	0.56	4.2	3500	0.00023	4.9
0.18	M3VRS 63 MA	3GVR 061 461-••C	2800	0.62	4.5	2.3	7.3	64.0	63.0	0.80	0.51	4.2	3500	0.00022	5
0.25	M3VRS 63 B	3GVR 061 452-••C	2810	0.87	7.5	3.6	8.33	77.5	75.8	0.71	0.66	4.5	3500	0.00026	5.4
0.25	M3VRS 63 MB	3GVR 061 462-••C	2800	0.86	4.5	2.2	5.2	68.0	66.0	0.83	0.64	4.2	3500	0.00028	6
0.37	M3VRS 71 A	3GVR 071 451-••E	2840	1.25	10	3.8	7.69	77.1	76.5	0.72	1.0	5.5	2600	0.00051	7
0.55	M3VRS 71 B	3GVR 071 452-••E	2830	1.86	10	3.6	5.26	79.2	78.2	0.76	1.35	5.7	2600	0.0006	8
0.75	M3VRS 80 A	3GVR 081 451-••E	2870	2.49	24	2.9	9.6	81.2	79.3	0.75	1.8	6.2	2000	0.00074	11
1.1	M3VRS 80 B	3GVR 081 452-••E	2850	3.69	24	2.3	6.48	81.4	79.5	0.78	2.5	6.1	2000	0.00078	12
1.5	M3ARS 90 S	3GAR 091 451-••E	2870	5.0	35	2.4	7.0	80.1	76.2	0.82	3.35	5.5	1300	0.021	19
2.2	M3ARS 90 L	3GAR 091 452-••E	2880	7.5	35	2.7	4.6	83.6	83.9	0.87	4.37	7.0	1200	0.0026	22
3	M3ARS 100 L	3GAR 101 451-••E	2900	10	44	2.7	4.4	86.0	84.1	0.88	5.95	7.5	1000	0.00453	32
4	M3ARS 112 M	3GAR 111 451-••E	2850	13.4	86	2.8	6.41	86.0	86.2	0.91	7.4	7.5	500	0.01078	38
5.5	M3ARS 132 SA	3GAR 131 451-••E	2855	18.4	130	3.2	7.06	86.0	86.6	0.88	10.5	7.8	600	0.01657	57
7.5	M3ARS 132 SB	3GAR 131 452-••E	2860	25.1	130	3.4	5.17	88.0	86.2	0.89	13.9	8.5	500	0.01857	62
11	M3ARS 160 MA	3GAR 161 461-••E	2915	36	200	2.1	5.55	88.4	88.0	0.88	20.5	6.1	200	0.05096	124
15	M3ARS 160 M	3GAR 161 462-••E	2900	49	200	2.3	4.1	89.4	89.7	0.90	27	6.0	200	0.05596	134
18.5	M3ARS 160 L	3GAR 161 463-••E	2915	60	200	2.5	3.3	90.4	90.7	0.91	32.5	6.7	200	0.06396	139
22	M3ARS 180 M	3GAR 181 461-••E	2925	72	200	3.0	2.8	91.5	91.7	0.89	39	8.0	120	0.06264	158
<b>3000 r/min = 2 poles</b>		<b>400 V 50 Hz</b>				<b>High-output design</b>									
0.37	M3VRS 63 BB	3GVR 061 453-••C	2800	1.29	7.5	2.3	5.76	73.6	73.1	0.81	0.9	3.5	3500	0.00027	5.9
0.68	M3VRS 71 BB	3GVR 071 453-••E	2800	2.33	10	3.2	4.34	78.9	77.4	0.82	1.59	5.2	2400	0.0006	8
0.75	M3VRS 71 BC	3GVR 071 454-••E	2800	2.57	10	3.1	3.84	78.5	77.9	0.85	1.7	5.1	2400	0.0006	8
1.5	M3VRS 80 C	3GVR 081 453-••E	2840	5.13	24	2.8	4.7	82.4	82.2	0.83	3.16	5.5	1800	0.00111	13
2.7	<sup>3)</sup> M3ARS 90 LB	3GAR 091 453-••E	2860	9.0	35	2.6	3.9	80.7	83.5	0.86	5.7	7.0	1200	0.0029	24
4	<sup>3)</sup> M3ARS 100 LB	3GAR 101 452-••E	2900	13	44	2.7	3.38	85.0	84.3	0.86	8.1	7.5	1000	0.00543	36
5.5	<sup>3)</sup> M3ARS 112 MB	3GAR 111 452-••E	2855	18.4	86	2.7	4.67	86.5	87.1	0.93	9.9	7.3	500	0.01273	66
9.2	<sup>3)</sup> M3ARS 132 SBB	3GAR 131 454-••E	2825	31.1	130	3.2	4.18	86.0	88.2	0.93	16.6	7.3	500	0.02457	77
11	<sup>3)</sup> M3ARS 132 SC	3GAR 131 453-••E	2835	37	130	3.2	3.51	87.0	87.4	0.93	19.6	8.0	500	0.02383	77
22	<sup>3)</sup> M3ARS 160 LB	3GAR 161 454-••E	2920	72	200	2.6	2.77	92.1		0.91	38	7.1	200	0.06896	145

<sup>1)</sup> Braking-torque ratio

<sup>2)</sup> No-load (shaft-free) operations/hour

<sup>3)</sup> Temperature rise class F.

The bullets in the product code indicate choice of mounting arrangement and voltage and frequency code, see below and ordering information page.

Code letters for supplementing product code for mounting arrangement:

Foot-mounted **A**  
 Flange-mounted, 1 flange **B** for frame sizes 63-100, 180; **E** for frame sizes 112-160.  
 Flange-mounted, 2 flanges **N** for frame sizes 90-132  
 Flange-mounted, small flange **C** for frame sizes 63-100

Code letters for supplementing product code for voltage and frequency (pos 13):

Motor size	S				D				G		H		X
	Motor 50 Hz	Motor 60 Hz	Brake 50 Hz	Brake 60 Hz	Motor 50 Hz	Motor 60 Hz	Brake 50 Hz	Brake 60 Hz	Motor 50 Hz	Motor 50 Hz	Motor 50 Hz	Brake 50 Hz	
<b>63-132</b>	220-240 VΔ 380-420 VY	250-280 VΔ 440-480 VY	230 VΔ 400 VY	265 VΔ 460 VY	380-420 VΔ 660-690 VY	440-480 VΔ -	400 VΔ 690 VY	460 VΔ -	-	-	-	-	Any other rated voltage or frequency, 690V maximum
<b>160-180</b>	230 VΔ 400 VY	265 VΔ 460 VY	230 VΔ 400 VY	265 VΔ 460 VY	400 VΔ 690 VY	460 VΔ -	400 VΔ 690 VY	460 VΔ -	415 VY	415 VY	415 VΔ	415 VΔ	

# General purpose brake motors

## Technical data for single-speed motors with three phase AC brake

IP 55 – IC 411 – Insulation class F, temperature rise class B – Brake IP 23 S

Output kW	Motor type	Product code	Torque						Efficiency		Power factor cos φ	Current			Moment of inertia J=1/4GD <sup>2</sup> kgm <sup>2</sup>	Weight Foot mounted kg
			Speed r/min	rated TN Nm	braking TB Nm	TS/ TN	K <sup>1)</sup>	100%	75%	IN A		IS/IN	c/h <sup>2)</sup>			
<b>1500 r/min = 4 poles</b>																
<b>400 V 50 Hz</b>																
<b>Basic design</b>																
0.12	M3VRS 63 A	3GVR 062 451-...C	1400	0.82	7.5	2.6	9.37	63.7	58.4	0.59	0.46	3.1	7100	0.00029	5	
0.12	M3VRS 63 MA	3GVR 062 461-...C	1365	0.84	4.5	2.0	5.4	54.0	52.0	0.66	0.49	2.8	7100	0.00026	5	
0.18	M3VRS 63 B	3GVR 062 452-...C	1380	1.25	7.5	2.5	5.76	65.6	62.1	0.64	0.63	3.1	7100	0.00036	5.5	
0.18	M3VRS 63 MB	3GVR 062 462-...C	1380	1.25	4.5	2.2	3.6	61.0	57.0	0.63	0.68	3.2	7100	0.00033	5	
0.25	M3VRS 71 A	3GVR 072 451-...E	1410	1.71	10	2.7	5.88	70.4	69.1	0.71	0.74	4.3	6500	0.00081	7	
0.37	M3VRS 71 B	3GVR 072 452-...E	1420	2.51	10	2.6	4.0	74.6	72.1	0.69	1.05	4.4	6500	0.00104	8	
0.55	M3VRS 80 A	3GVR 082 451-...E	1390	3.75	24	2.6	6.31	75.3	73.1	0.76	1.4	4.6	5000	0.00128	11	
0.75	M3VRS 80 B	3GVR 082 452-...E	1410	5.08	24	3.5	4.7	78.2	75.6	0.74	1.9	4.7	5000	0.00159	12	
1.1	M3ARS 90 S	3GAR 092 451-...E	1410	7.5	35	2.2	4.66	77.5	76.4	0.81	2.59	5.0	3200	0.0034	19	
1.5	M3ARS 90 L	3GAR 092 452-...E	1420	10	35	2.4	3.5	80.3	78.1	0.79	3.45	5.0	3200	0.0045	22	
2.2	M3ARS 100 LA	3GAR 102 451-...E	1430	15	44	2.4	2.93	83.0	82.7	0.81	4.8	5.5	2700	0.00733	32	
3	M3ARS 100 LB	3GAR 102 452-...E	1430	20	44	2.5	2.2	85.0	83.9	0.81	6.48	5.5	2700	0.00863	35	
4	M3ARS 112 M	3GAR 112 451-...E	1435	26.6	86	2.9	3.23	84.5	83.9	0.80	8.6	7.0	2500	0.01578	40	
5.5	M3ARS 132 S	3GAR 132 451-...E	1450	36.2	130	2.2	3.59	87.0	87.7	0.83	11.1	7.3	1800	0.03357	60	
7.5	M3ARS 132 M	3GAR 132 452-...E	1450	49.4	130	2.5	2.63	88.0	88.6	0.83	14.8	7.9	1400	0.04057	68	
11	M3ARS 160 M	3GAR 162 461-...E	1465	72	230	2.4	3.2	88.4	88.8	0.78	22.5	6.9	500	0.07696	117	
15	M3ARS 160 L	3GAR 162 462-...E	1460	98	230	2.8	2.3	90.0	90.5	0.82	29	7.2	500	0.08796	129	
18.5	M3ARS 180 M	3GAR 182 461-...E	1455	121	230	2.6	1.9	90.4	90.4	0.84	35	7.0	360	0.10464	161	
22	M3ARS 180 L	3GAR 182 462-...E	1460	144	230	3.0	1.6	91.1	91.5	0.82	42	8.0	360	0.12964	175	
<b>1500 r/min = 4 poles</b>																
<b>400 V 50 Hz</b>																
<b>High-output design</b>																
0.25	M3VRS 63 BB	3GVR 062 453-...C	1370	1.75	7.5	2.5	4.28	70.3	67.4	0.67	0.78	3.2	7100	0.0004	6	
0.45	M3VRS 71 BB	3GVR 072 453-...E	1390	3.11	10	2.1	3.22	75.5	75.3	0.76	1.15	4.1	6500	0.00104	8	
0.55	M3VRS 71 C	3GVR 072 454-...E	1410	3.74	10	2.7	2.7	77.3	76.9	0.73	1.45	4.8	6500	0.00125	9	
0.95	M3VRS 80 C	3GVR 082 453-...E	1410	6.44	24	2.9	3.75	78.9	77.9	0.75	2.35	4.3	500	0.00197	13	
1.85 <sup>3)</sup>	M3ARS 90 L	3GAR 092 453-...E	1390	13	35	2.2	2.69	79.5	78.1	0.80	4.4	4.5	3200	0.0045	22	
2.2 <sup>3)</sup>	M3ARS 90 LB	3GAR 092 454-...E	1390	15	35	2.2	2.33	80.3	81.0	0.83	4.85	4.5	3200	0.0048	23	
4 <sup>3)</sup>	M3ARS 100 LC	3GAR 102 453-...E	1420	27	44	2.5	1.62	81.0	81.7	0.82	8.65	5.5	2700	0.009	36	
5.5 <sup>3)</sup>	M3ARS 112 MB	3GAR 112 452-...E	1425	36.9	86	2.8	2.14	84.5	83.5	0.83	11.4	7.1	2500	0.018	47	
9.2 <sup>3)</sup>	M3ARS 132 MBA	3GAR 132 454-...E	1450	60	130	2.0	2.14	88.0	88.6	0.85	17.8	7.3	1400	0.05	83	
11 <sup>3)</sup>	M3ARS 132 MB	3GAR 132 453-...E	1450	72	130	2.5	1.79	88.0	89.4	0.86	21	8.3	500	0.05	83	
18.5 <sup>3)</sup>	M3ARS 160 LB	3GAR 162 453-...E	1450	122	230	2.9	1.88	90.5	88.9	0.84	36	6.9	500	0.107	143	

<sup>1)</sup> Braking-torque ratio

<sup>2)</sup> No-load (shaft-free) operations/hour

<sup>3)</sup> Temperature rise class F.

The bullets in the product code indicate choice of mounting arrangement and voltage and frequency code, see below and ordering information page.

### Code letters for supplementing product code for mounting arrangement:

Foot-mounted **A**  
 Flange-mounted, 1 flange **B** for frame sizes 63-100, 180; **E** for frame sizes 112-160.  
 Flange-mounted, 2 flanges **N** for frame sizes 90-132  
 Flange-mounted, small flange **C** for frame sizes 63-100

### Code letters for supplementing product code for voltage and frequency (pos 13):

Motor size	<b>S</b>				<b>D</b>				<b>G</b>		<b>H</b>		<b>X</b>
	Motor 50 Hz	Motor 60 Hz	Brake 50 Hz	Brake 60 Hz	Motor 50 Hz	Motor 60 Hz	Brake 50 Hz	Brake 60 Hz	Motor 50 Hz	Motor 50 Hz	Motor 50 Hz	Brake 50 Hz	
<b>63-132</b>	220-240 VΔ 380-420 VY	250-280 VΔ 440-480 VY	230 VΔ 400 VY	265 VΔ 460 VY	380-420 VΔ 660-690 VY	440-480 VΔ -	400 VΔ 690 VY	460 VΔ -	-	-	-	-	Any other rated voltage or frequency, 690V maximum
<b>160-180</b>	230 VΔ 400 VY	265 VΔ 460 VY	230 VΔ 400 VY	265 VΔ 460 VY	400 VΔ 690 VY	460 VΔ -	400 VΔ 690 VY	460 VΔ -	415 VY	415 VY	415 VΔ	415 VΔ	

# General purpose brake motors

## Technical data for single-speed motors with three phase AC brake

IP 55 – IC 411 – Insulation class F, temperature rise class B – Brake IP 23 S

Output Motor kW type	Product code	Torque							Efficiency		Power factor cos φ	Current			Moment of inertia J=1/4GD <sup>2</sup> kgm <sup>2</sup>	Weight Foot mounted kg	
		Speed r/min	TN Nm	braking TB Nm	TS/ TN	K <sup>1)</sup>	100%	75%	IN A	IS/IN		c/h <sup>2)</sup>					
<b>1000 r/min = 6 poles</b>		<b>400 V 50 Hz</b>							<b>Basic design</b>								
0.09	M3VRS 63 A	3GVR 063 451-••C	910	0.95	7.5	2.1	7.5	47.1	42.5	0.56	0.51	2.1	7700	0.0003	5		
0.12	M3VRS 63 B	3GVR 063 452-••C	860	1.27	7.5	1.8	5.76	56.0	53.5	0.55	0.56	2.4	7700	0.00037	5.5		
0.12	M3VRS 63 MB	3GVR 063 462-••C	860	1.27	4.5	1.8	3.5	56.0	50.0	0.55	0.56	2.5	7700	0.00033	5		
0.18	M3VRS 71 A	3GVR 073 451-••E	920	1.88	10	2.1	5.26	61.1	57.7	0.69	0.64	2.9	7500	0.00078	7		
0.25	M3VRS 71 B	3GVR 073 452-••E	920	2.61	10	2.5	3.84	64.9	62.3	0.65	0.86	3.2	7500	0.00096	8		
0.37	M3VRS 80 A	3GVR 083 451-••E	925	3.82	24	3.1	6.15	72.9	70.8	0.72	1.04	3.8	7000	0.00186	11		
0.55	M3VRS 80 B	3GVR 083 452-••E	925	5.68	24	2.9	4.06	73.3	71.9	0.71	1.55	3.4	7000	0.0022	12		
0.75	M3ARS 90 S	3GAR 093 451-••E	930	7.5	35	1.9	4.66	71.5	70.7	0.67	2.36	4.0	3800	0.0034	19		
1.1	M3ARS 90 L	3GAR 093 452-••E	930	11	35	2.1	3.18	74.4	72.5	0.69	3.25	4.0	3900	0.0045	22		
1.5	M3ARS 100 L	3GAR 103 451-••E	950	15	44	1.9	2.93	80.0	77.0	0.71	3.92	4.5	3300	0.0086	34		
2.2	M3ARS 112 M	3GAR 113 451-••E	940	22.3	86	2.1	3.85	80.5	79.3	0.74	5.4	5.6	3200	0.015	40		
3	M3ARS 132 S	3GAR 133 451-••E	960	29.8	130	2.0	4.36	84.5	82.7	0.75	6.9	6.1	2400	0.033	59		
4	M3ARS 132 MA	3GAR 133 452-••E	960	39.7	130	2.0	3.27	85.5	83.1	0.78	8.7	7.1	1900	0.04	66		
5.5	M3ARS 132 MB	3GAR 133 453-••E	955	55	130	2.2	2.36	86.0	85.0	0.78	11.9	6.9	1900	0.047	74		
7.5	M3ARS 160 M	3GAR 163 451-••E	970	74	230	2.0	3.14	89.3	88.4	0.79	15.4	6.7	600	0.087	129		
11	M3ARS 160 L	3GAR 163 452-••E	970	109	230	2.2	2.13	89.8	88.5	0.78	23	7.1	600	0.127	149		
<b>1000 r/min = 6 poles</b>		<b>400 V 50 Hz</b>							<b>High-output design</b>								
0.15	M3VRS 63 BB	3GVR 063 453-••C	900	1.61	7.5	2.2	4.68	56.9	52.1	0.54	0.74	2.2	7700	0.00042	6		
0.32	M3VRS 71 C	3GVR 073 453-••E	920	3.33	10	2.6	3.1	64.8	61.6	0.63	1.15	3.2	7500	0.00125	9		
1.3	<sup>3)</sup> M3ARS 90 LB	3GAR 093 453-••E	910	13.5	24	1.9	2.59	69.0	69.0	0.71	3.85	4.0	3800	0.005	24		
2.2	<sup>3)</sup> M3ARS 100 LC	3GAR 103 452-••E	940	22	35	1.9	2	77.0	72.8	0.71	5.9	4.5	3300	0.009	37		
3	<sup>3)</sup> M3ARS 112 MB	3GAR 113 452-••E	935	30.6	44	2.0	2.81	80.0	79.9	0.76	7.2	5.5	3200	0.018	46		
6.5	<sup>3)</sup> M3ARS 132 MC	3GAR 133 454-••E	960	64	130	2.0	2.01	85.0	84.5	0.75	14.8	6.6	2400	0.051	79		
14	<sup>3)</sup> M3ARS 160 LB	3GAR 163 453-••E	960	139	230	2.7	1.65	89.1	84.5	0.77	29.5	7.6	1900	0.147	164		

<sup>1)</sup> Braking-torque ratio

<sup>2)</sup> No-load (shaft-free) operations/hour

<sup>3)</sup> Temperature rise class F.

The bullets in the product code indicate choice of mounting arrangement and voltage and frequency code, see below and ordering information page.

Code letters for supplementing product code for mounting arrangement:

Foot-mounted **A**  
 Flange-mounted, 1 flange **B** for frame sizes 63-100, 180; **E** for frame sizes 112-160.  
 Flange-mounted, 2 flanges **N** for frame sizes 90-132  
 Flange-mounted, small flange **C** for frame sizes 63-100

Code letters for supplementing product code for voltage and frequency (pos 13):

Motor size	S				D				G		H		X
	Motor 50 Hz	Motor 60 Hz	Brake 50 Hz	Brake 60 Hz	Motor 50 Hz	Motor 60 Hz	Brake 50 Hz	Brake 60 Hz	Motor 50 Hz	Motor 50 Hz	Motor 50 Hz	Motor 50 Hz	
<b>63-132</b>	220-240 VΔ 380-420 VY	250-280 VΔ 440-480 VY	230 VΔ 400 VY	265 VΔ 460 VY	380-420 VΔ 660-690 VY	440-480 VΔ -	400 VΔ 690 VY	460 VΔ -	-	-	-	-	Any other rated voltage or frequency, 690V maximum
<b>160-180</b>	230 VΔ 400 VY	265 VΔ 460 VY	230 VΔ 400 VY	265 VΔ 460 VY	400 VΔ 690 VY	460 VΔ -	400 VΔ 690 VY	460 VΔ -	415 VY	415 VY	415 VΔ	415 VΔ	

# General purpose brake motors

## Technical data for single-speed motors with three phase AC brake

IP 55 – IC 411 – Insulation class F, temperature rise class B – Brake IP 23 S

Output kW	Motor type	Product code	Torque						Efficiency		Power factor cos φ	Current			Moment of inertia J=1/4GD <sup>2</sup> kgm <sup>2</sup>	Weight Foot mounted kg
			Speed r/min	rated TN Nm	braking		TS/ K <sup>1)</sup>	100%	75%	IN A		IS/IN	c/h <sup>2)</sup>			
<b>750 r/min = 8 poles</b>			<b>400 V 50 Hz</b>								<b>Basic design</b>					
0.055	M3VRS 63 B	3GVR 064 451-...C	680	0.78	7.5	2.1	9.4	38.3	31.8	0.48	0.45	1.8	7700	0.00037	5.5	
0.09	M3VRS 71 A	3GVR 074 451-...E	690	1.25	10	2.3	7.69	45.8	37.5	0.57	0.52	2.2	7500	0.00078	7	
0.12	M3VRS 71 B	3GVR 074 452-...E	690	1.67	10	2.5	5.88	46.4	38.1	0.55	0.69	2.2	7500	0.00096	8	
0.18	M3VRS 80 A	3GVR 084 451-...E	700	2.46	24	3.2	9.6	59.9	54.5	0.60	0.75	3.1	7500	0.0022	11	
0.25	M3VRS 80 B	3GVR 084 452-...E	700	3.52	24	2.9	6.85	70.7	67.4	0.62	0.85	3.1	7500	0.00245	12	
0.37	M3ARS 90 S	3GAR 094 451-...E	700	5.0	35	1.9	7.0	61.5	43.4	0.56	1.6	3.0	4100	0.0034	19	
0.55	M3ARS 90 L	3GAR 094 452-...E	690	7.5	35	1.7	4.66	62.9	56.4	0.57	2.35	3.0	4100	0.0045	22	
0.75	M3ARS 100 LA	3GAR 104 451-...E	700	10	44	2.1	4.4	72.0	63.6	0.59	2.55	3.5	3600	0.0073	31	
1.1	M3ARS 100 LB	3GAR 104 452-...E	700	15	44	2.1	2.93	73.0	68.8	0.64	3.35	3.5	3700	0.0086	34	
1.5	M3ARS 112 M	3GAR 114 451-...E	695	20.6	86	1.9	4.17	74.5	75.9	0.65	4.5	4.1	3600	0.016	41	
2.2	M3ARS 132 S	3GAR 134 451-...E	720	29.2	130	1.6	4.45	80.5	77.8	0.67	5.9	5.3	3000	0.04	66	
3	M3ARS 132 M	3GAR 134 452-...E	720	39.8	130	1.8	3.26	82.0	79.2	0.68	7.8	5.5	2600	0.047	73	
4	M3ARS 160 MA	3GAR 164 451-...E	715	54	230	2.1	4.39	84.1	81.1	0.69	10	5.2	600	0.11	139	
5.5	M3ARS 160 M	3GAR 164 452-...E	710	74	230	2.4	3.17	84.7	75.0	0.70	13.4	5.4	600	0.11	139	
7.5	M3ARS 160 L	3GAR 164 453-...E	715	100	230	2.4	2.31	86.3	82.4	0.70	18.1	5.4	600	0.127	154	

<sup>1)</sup> Braking-torque ratio

<sup>2)</sup> No-load (shaft-free) operations/hour

The bullets in the product code indicate choice of mounting arrangement and voltage and frequency code, see below and ordering information page.

### Code letters for supplementing product code for mounting arrangement:

Foot-mounted **A**  
 Flange-mounted, 1 flange **B** for frame sizes 63-100, 180; **E** for frame sizes 112-160.  
 Flange-mounted, 2 flanges **N** for frame sizes 90-132  
 Flange-mounted, small flange **C** for frame sizes 63-100

### Code letters for supplementing product code for voltage and frequency (pos 13):

Motor size	S				D				G		H		X
	Motor 50 Hz	Motor 60 Hz	Brake 50 Hz	Brake 60 Hz	Motor 50 Hz	Motor 60 Hz	Brake 50 Hz	Brake 60 Hz	Motor 50 Hz	Motor 50 Hz	Motor 50 Hz	Brake 50 Hz	
<b>63-132</b>	220-240 VΔ 380-420 VY	250-280 VΔ 440-480 VY	230 VΔ 400 VY	265 VΔ 460 VY	380-420 VΔ 660-690 VY	440-480 VΔ -	400 VΔ 690 VY	460 VΔ -	-	-	-	-	Any other rated voltage or frequency, 690V maximum
<b>160-180</b>	230 VΔ 400 VY	265 VΔ 460 VY	230 VΔ 400 VY	265 VΔ 460 VY	400 VΔ 690 VY	460 VΔ -	400 VΔ 690 VY	460 VΔ -	415 VY	415 VY	415 VΔ	415 VΔ	

# General purpose brake motors

## Technical data for two-speed motors with three phase AC brake

IP 55 – IC 411 – Insulation class F, temperature rise class F – Brake IP 23 S

Output kW	Motor type	Product code	Speed r/min	Torque		TS/TN	K <sup>1)</sup>	Efficiency %	Power factor cos φ	Current		Moment of inertia J=1/4GD <sup>2</sup> kgm <sup>2</sup>	Weight IM 1001 kg
				rated TN Nm	braking TB Nm					IN	IS/IN A		
<b>3000/1500 r/min = 2-4 poles</b>				<b>400 V 50 Hz</b>				<b>Constant torque, two separate windings</b>					
1.1/0.55	M3ARS 90 S	3GAR 098 451-**-E	2900/1450	3.6/3.6	35	1.4/1.5	9.7/9.7	74/62	0.85/0.64	2.5/2	5.1/3.6	0.0019	20
1.5/0.75	M3ARS 90 L	3GAR 098 452-**-E	2900/1450	4.9/4.9	35	1.5/1.5	7.1/7.1	77/70	0.87/0.67	3.3/2.4	5.7/4.1	0.0024	23
2/1	M3ARS 100 L	3GAR 108 451-**-E	2900/1460	6.5/6.5	44	1.9/1.4	7.7/7.7	76/67	0.89/0.66	4.3/3.3	6.2/4	0.0041	32
2.6/1.3	M3ARS 112 M	3GAR 118 451-**-E	2900/1460	8.6/8.5	86	1.6/1.6	10/9.9	80/75	0.92/0.72	5.1/3.5	6.4/5	0.012	45
4.4/2.2	M3ARS 132 SB	3GAR 138 451-**-E	2925/1450	14.4/14.5	130	2/1.3	10.4/10	81/74	0.86/0.73	9.1/5.9	7.3/4.5	0.016	55
5.6/2.8	M3ARS 132 M	3GAR 138 452-**-E	2885/1440	18.5/18.6	130	1.8/1.4	8.1/8.1	82/77	0.93/0.75	10.6/7	6.7/5	0.022	76
<b>3000/1500 r/min = 2-4 poles</b>				<b>400 V 50 Hz</b>				<b>Constant torque, Dahlander connection</b>					
0.2/0.15	M3VRS 63 A	3GVR 068 451-**-C	2800/1400	0.68/1.02	7.5	2.1/2	11/7.4	63/54	0.7/0.63	0.65/0.65	3.6/2.8	0.00019	5
0.3/0.2	M3VRS 63 B	3GVR 068 452-**-C	2740/1370	1.05/1.4	7.5	1.7/2.1	7.1/5.4	59/55	0.78/0.63	0.95/0.85	2.8/2.8	0.00026	5.5
0.37/0.25	M3VRS 71 A	3GVR 078 451-**-E	2700/1390	1.3/1.72	10	1.9/1.5	9.2/7	64/60	0.89/0.79	0.95/0.7	3.3/3.1	0.00066	7
0.48/0.31	M3VRS 71 B	3GVR 078 452-**-E	2780/1400	1.66/2.15	10	1.4/2	7.1/5.6	68/68	0.91/0.76	1.2/0.9	3.6/4	0.00089	8
0.55/0.37	M3VRS 71 C	3GVR 078 453-**-E	2800/1400	1.87/2.52	10	1.8/1.9	6.4/4.8	66/64	0.8/0.65	1.5/1.2	4.7/4.3	0.0011	8.5
0.63/0.5	M3VRS 80 A	3GVR 088 451-**-E	2690/1400	2.25/3.42	24	1.8/1.9	7.6/5.5	66/67	0.87/0.79	1.6/1.35	3.6/4.2	0.0013	11
0.85/0.65	M3VRS 80 B	3GVR 088 452-**-E	2725/1405	2.99/4.43	24	1.9/2	5.4/3.6	70/70	0.88/0.8	2/1.7	4/4.4	0.0016	12.5
1.1/0.8	M3VRS 80 C	3GVR 088 453-**-E	2730/1410	3.8/5.38	24	2/2	4.7/3.3	72/71	0.88/0.79	2.55/2.05	4.2/4.7	0.002	13
1.3/1	M3ARS 90 S	3GAR 098 453-**-E	2730/1400	4.5/6.8	35	2/1.5	7.8/5.1	71/71	0.88/0.8	3.1/2.6	3.9/3.8	0.0032	20
1.9/1.5	M3ARS 90 L	3GAR 098 454-**-E	2820/1420	6.4/10	35	2.8/2		74/75	0.82/0.76	4.4/3.9	5.1/4.4	0.0043	23
2.5/2.1	M3ARS 100 LA	3GAR 108 452-**-E	2800/1430	8.5/14	44	2.2/1.6	5.9/3.6	68/76	0.88/0.81	6/5	4.8/4.4	0.0069	32
3.4/2.5	M3ARS 100 LB	3GAR 108 453-**-E	2810/1430	11.5/18	44	2.2/1.9	4.3/2.7	78/80	0.88/0.85	7.2/5.9	5.3/5.4	0.0082	35
4.26	M3ARS 112 M	3GAR 118 452-**-E	2865/1430	13.3/17.4	86	1.8/2.3	10/9.9	82/77	0.93/0.76	7.6/6.5	6.3/6.2	0.012	45
6.3/4.4	M3ARS 132 SA	3GAR 138 461-**-E	2895/1445	20.8/29	130	1.7/1.6	7.2/5.2	85/84	0.94/0.8	11.4/9.5	6.5/5.7	0.0155	58
4.7/3.1	M3ARS 132 SB	3GAR 138 453-**-E	2820/1420	15.9/20.8	130	1.8/2.2	10.4/10	79/77	0.92/0.76	9.2/7.7	5.5/5.7	0.016	55
8/6.2	M3ARS 132 SC	3GAR 138 462-**-E	2910/1440	26.2/41.1	130	1.9/1.6	6.9/3.6	87/85	0.95/0.83	14/12.7	7.8/5.6	0.0215	78
7.2/4.8	M3ARS 132 M	3GAR 138 454-**-E	2870/1435	24/31.9	130	2.4/2.5	6.3/4.7	84/81	0.92/0.76	13.3/11.5	7.1/6.2	0.022	76
9.6/7	M3ARS 132 MD	3GAR 138 453-**-E	2900/1440	31.6/46.4	130	1.8/1.7	4.7/3.2	87/85	0.95/0.85	16.8/14.1	7.6/5.9	0.026	85
12.5/9	M3ARS 160 M	3GAR 168 454-**-E	2890/1440	41/60	200	1.4/1.8	5.6/3.8	85.5/85.5	0.93/0.8	22.5/19	5.2/4.6	0.054	129
15/10.5	M3ARS 160 L	3GAR 168 455-**-E	2900/1445	49/69	200	1.6/2.1	4.7/3.3	87/86	0.93/0.77	27/23	5.8/4.9	0.057	139
<b>1500/1000 r/min = 4/6 poles</b>				<b>400 V 50 Hz</b>				<b>Constant torque, two separate windings</b>					
0.11/0.08	M3VRS 63 B	3GVR 068 453-**-C	1390/860	0.75/0.88	7.5	1.4/1.8	10/8.5	40/25	0.7/0.72	0.55/0.62	2.5/1.8	0.00026	5.5
0.3/0.2	M3VRS 71 A	3GVR 078 454-**-E	1390/900	1.37/0.79	10	1.1/1.05	15.2/8.8	51/40	0.82/0.72	0.7/0.5	2.8/2	0.00066	7
0.37/0.22	M3VRS 71 B	3GVR 078 455-**-E	1380/900	2.07/1.91	10	1/1.1	6.3/5.8	58/40	0.83/0.8	0.9/0.8	2.7/1.9	0.00089	8
0.43/0.28	M3VRS 80 A	3GVR 088 454-**-E	1380/910	2.54/3.02	24	1.5/1.4	7.1/6	60/54	0.85/0.81	1.4/1.2	3.1/2.9	0.0019	12
0.58/0.37	M3VRS 80 B	3GVR 088 455-**-E	1390/920	4.3/1.985	24	1.5/1.5	4/3.5	63/58	0.85/0.8	1.6/1.15	3.3/3.2	0.0022	12.5
0.8/0.5	M3ARS 90 S	3GAR 098 455-**-E	1430/940	5.3/5	35	1.5/1.4	7/6.6	68/57	0.8/0.66	2.2/2	3.9/2.8	0.0032	20
1.2/0.75	M3ARS 90 L	3GAR 098 456-**-E	1430/940	8/7.6	35	1.7/1.5	4.6/4.4	73/63	0.81/0.67	3/2.6	4.4/3.1	0.0043	23
1.5/0.9	M3ARS 100 LA	3GAR 108 454-**-E	1440/960	9.9/8.9	44	1.5/1.5	5.6/5.1	75/69	0.84/0.65	3.5/3	4.7/3.8	0.0069	32
1.8/1.1	M3ARS 100 LB	3GAR 108 455-**-E	1460/960	11/11	44	2.1/1.6	4.5/4.5	77/70	0.78/0.64	4.4/3.6	5.8/3.9	0.0082	35
2.6/1.7	M3ARS 112 M	3GAR 118 453-**-E	1445/960	17.2/16.9	86	1.5/1.5	5/4.9	80/70	0.85/0.76	5.5/4.4	5.9/5.2	0.018	45
3.3/2.2	M3ARS 132 S	3GAR 138 455-**-E	1470/980	21.4/21.4	130	1.4/1.2	7/7	82/76	0.8/0.65	7.1/6.4	6.8/4.6	0.038	61
4.5/3	M3ARS 132 M	3GAR 138 456-**-E	1470/980	29.2/29.2	130	1.4/1.5	5.1/5.1	82/77	0.81/0.7	9.8/8	7.2/5.6	0.048	79
5.5/3.7	M3ARS 132 MD	3GAR 138 464-**-E	1460/960	36/36.8	130	1.9/1.8	4.2/4.2	85/81	0.88/0.8	10.7/8.3	8/6.3	0.036	84
7.5/5.5	M3ARS 160 M	3GAR 168 456-**-E	1465/965	49/54	230	2.1/1.8	3.1/2.7	85.5/80.5	0.83/0.77	15.5/13	7.1/4.7	0.089	129
11.5/8.5	M3ARS 160 L	3GAR 168 457-**-E	1465/965	75/84	230	2.1/1.8	2.9/2.7	86.5/82.5	0.84/0.76	23/19.5	7/4.9	0.119	139

<sup>1)</sup> Braking-torque ratio



# General purpose brake motors

## Technical data for two-speed motors with three phase AC brake

IP 55 – IC 411 – Insulation class F, temperature rise class F – Brake IP 23 S

Output kW	Motor type	Product code	Speed r/min	Torque				Efficiency %	Power factor cos φ	Current		Moment of inertia J=1/4GD <sup>2</sup> kgm <sup>2</sup>	Weight IM 1001 kg
				TN Nm	braking TB Nm	TS/TN	K <sup>1)</sup>			IN	IS/IN A		
<b>3000/750 r/min = 2/8 poles</b>			<b>400 V 50 Hz</b>				<b>Constant torque, two separate windings</b>						
0.25/0.06	M3VRS 71 A	3GVR 078 458-***E	2760/660	0.86/0.86	10	1/1.3	14/14	52/36	0.94/0.7	0.75/0.35	2.9/1.9	0.00066	7
0.37/0.09	M3VRS 71 B	3GVR 078 459-***E	2800/660	1.26/1.3	10	1/1.6	9.5/9.2	68/41	0.87/0.65	0.9/0.5	2.8/2	0.00089	8
0.5/0.12	M3VRS 80 A	3GVR 088 459-***E	2730/700	1.78/1.64	24	1.3/2	10.9/9.6	60/38	0.87/0.58	1.4/0.8	3.2/2.3	0.0013	12.5
0.66/0.15	M3VRS 80 B	3GVR 088 460-***E	2780/700	2.55/2.45	24	1.4/2.2	7.3/7.1	65/40	0.87/0.58	1.65/0.95	3.8/2.5	0.0016	13
0.75/0.18	M3ARS 90 LA	3GAR 098 461-***E	2875/720	2.5/2.4	35	2.3/1.3	14/14	71.2/46.3	0.8/0.51	1.9/1.1	5.7/2.4	0.0043	23
1.3/0.33	M3ARS 90 LB	3GAR 098 462-***E	2780/690	4.4/4.5	35	1.8/1.2	8/8	71/52	0.92/0.62	2.9/1.5	4.5/2.3	0.0043	23
1.8/0.5	M3ARS 100 LB	3GAR 108 460-***E	2860/705	6/6.7	44	1.7/1.3	8.3/7.4	80/54	0.93/0.64	3.5/2.1	5.3/2.6	0.0082	35
2.2/0.59	M3ARS 112 MC	3GAR 118 456-***E	2900/720	7.2/7.8	86	2.4/1.6	11.8/11	78/62	0.87/0.55	4.9/2.5	7/3.5	0.015	42
3.3/0.95	M3ARS 132 SA	3GAR 138 465-***E	2940/730	10.7/12.4	130	2.6/1.2	14/12	81/72	0.95/0.52	6.2/3.7	9.5/4.3	0.0215	65
4.4/1.3	M3ARS 132 MC	3GAR 138 466-***E	2920/725	14.4/17.1	130	2.2/1.3	10.7/8.8	82/74	0.94/0.62	8.3/4.1	8.6/4	0.03	77
<b>1500/750 r/min = 4/8 poles</b>			<b>400 V 50 Hz</b>				<b>Constant torque, two separate windings</b>						
0.55/0.25	M3ARS 90 S	3GAR 098 457-***E	1450/700	3.6/3.4	35	1.3/1.4	10.3/9.7	62/51	0.78/0.59	1.9/1.2	4.2/2.3	0.0032	20
0.75/0.37	M3ARS 90 L	3GAR 098 458-***E	1450/700	4.9/5	35	1.4/1.5	7.1/7	66/57	0.75/0.57	2.2/1.7	4.1/2.5	0.0043	23
1.1/0.55	M3ARS 100 LA	3GAR 108 456-***E	1460/710	7.2/7.4	44	1.2/1.2	6.9/6.8	68/62	0.77/0.61	3.1/2.2	4.2/2.6	0.0069	32
1.5/0.75	M3ARS 100 LB	3GAR 108 457-***E	1440/700	9.8/10	44	1.3/1.2	5.1/5	72/60	0.82/0.6	3.7/2.9	4.6/2.7	0.0082	35
1.8/0.9	M3ARS 112 M	3GAR 118 454-***E	1460/715	11.7/12	86	1.2/1.6	7.3/7.1	77/65	0.76/0.66	4.4/3	6.5/4	0.018	45
2.5/1.3	M3ARS 132 S	3GAR 138 457-***E	1480/735	16.2/17	130	1.6/1.4	9.3/8.8	80/67	0.79/0.56	5.8/6	6/3.7	0.038	61
3.3/1.7	M3ARS 132 M	3GAR 138 458-***E	1470/725	21.4/22.4	130	1.6/1.4	7/6.7	81/71	0.79/0.58	7.5/6	7/4.2	0.048	79
<b>1500/750 r/min = 4-8 poles</b>			<b>400 V 50 Hz</b>				<b>Constant torque, Dahlander connection</b>						
0.11/0.06	M3VRS 63 B	3GVR 068 454-***C	1390/660	0.75/0.87	7.5	1.6/2.5	10/8.6	54/33	0.6/0.49	0.5/0.55	3/1.7	0.00026	5.5
0.18/0.11	M3VRS 71 A	3GVR 078 456-***E	1380/680	1.24/1.54	10	1.9/2.2	9.7/7.8	54/37	0.7/0.53	0.7/0.8	3.2/2.5	0.00066	7
0.3/0.15	M3VRS 71 B	3GVR 078 457-***E	1400/700	2.05/2.05	10	2/2.5	5.9/5.9	60/47	0.74/0.51	0.9/0.9	3.2/2.6	0.00089	8
0.45/0.25	M3VRS 80 A	3GVR 088 456-***E	1380/700	3.12/3.42	24	1.7/2.1	6.5/6	65/48	0.87/0.58	1.15/1.3	3.5/2.7	0.0019	11
0.63/0.33	M3VRS 80 B	3GVR 088 457-***E	1380/705	4.37/4.48	24	1.7/2.2	4/3.9	67/50	0.88/0.56	1.55/1.7	3.5/2.8	0.0022	12
0.75/0.37	M3VRS 80 C	3GVR 088 458-***E	1390/710	5.16/4.98	24	1.9/2.5	3.6/3.5	70/52	0.86/0.51	1.8/2	3.9/2.9	0.0025	12.5
0.7/0.37	M3ARS 90 S	3GAR 098 459-***E	1420/700	4.7/5.1	35	1.6/1.6	7.4/6.9	72/50	0.8/0.57	1.8/1.9	4.4/2.3	0.0032	20
1.1/0.55	M3ARS 90 L	3GAR 098 460-***E	1390/685	7.4/7.5	35	1.4/1.5	4.7/4.7	70/55	0.84/0.58	2.6/2.6	4.1/2.3	0.0043	23
1.5/0.75	M3ARS 100 LA	3GAR 108 458-***E	1440/710	10/10	44	1.4/1.5	5/5	76/62	0.85/0.57	3.4/3.2	4.6/2.8	0.0069	32
2/0.95	M3ARS 100 LB	3GAR 108 459-***E	1440/710	13/12	44	1.4/1.6	4.2/3.8	78/64	0.86/0.55	4.4/4	4.8/2.9	0.0082	35
2.5/1.5	M3ARS 112 M	3GAR 118 455-***E	1410/705	16.9/20.3	86	1.4/1.5	5/4.2	78/67	0.9/0.66	5.1/4.9	5.5/4.1	0.018	45
3.8/1.9	M3ARS 132 S	3GAR 138 459-***E	1450/730	25/24.9	130	1.4/1.3	6/6	82/70	0.84/0.52	7.7/7.6	5.6/3.7	0.038	61
5/2.5	M3ARS 132 M	3GAR 138 460-***E	1455/730	32.8/32.7	130	1.7/2	4.6/4.6	85/73	0.88/0.52	9.6/9.6	6.9/4.8	0.048	79
8/4.5	M3ARS 160 M	3GAR 168 460-***E	1440/730	53/59	230	1.3/1.4	4.3/3.9	84.5/79.5	0.86/0.6	16/13.5	4.5/3.4	0.089	129
12/7	M3ARS 160 L	3GAR 168 461-***E	1445/730	79/92	230	1.5/1.4	2.9/2.5	86.5/81	0.87/0.59	23/21	5/3.5	0.119	139

<sup>1)</sup> Braking-torque ratio

The bullets in the product code indicate choice of mounting arrangement and voltage and frequency code, see below and ordering information page.

Code letters for supplementing product code for mounting arrangement (pos 12):

Foot-mounted	<b>A</b>
Flange-mounted, 1 flange	<b>B</b> for frame sizes 63-100, 180; <b>E</b> for frame sizes 112-160.
Flange-mounted, 2 flanges	<b>N</b> for frame sizes 90-132
Flange-mounted, small flange	<b>C</b> for frame sizes 63-100

Code letters for supplementing product code for voltage and frequency (pos 13):

Motor size	<b>A</b>		<b>B</b>		<b>S</b>		<b>D</b>	
	Motor 50 Hz	Brake 50 Hz	Motor 50 Hz	Brake 50 Hz	Motor 50 Hz	Brake 50 Hz	Motor 50 Hz	Brake 50 Hz
63-132	–	–	–	–	220-230 V	230 VΔ	380-400 V	400 VΔ
160	220 V	220 VΔ	380 V	380 VΔ	230 V	230 VΔ	400 V	400 VΔ
Motor size	<b>E</b>		<b>H</b>		<b>X</b>			
	Motor 50 Hz	Brake 50 Hz	Motor 50 Hz	Brake 50 Hz	Any other rated voltage or frequency, 690 V maximum			
63-132	500 V	500 VΔ	415 V	415 VΔ				
160	500 V	500 VΔ	415 V	415 VΔ				

# General purpose brake motors - Variant codes

Code	Variant	M3VRF/S			M3ARF/S					
		63	71	80	90	100	112	132	160	180
<b>Brakes</b>										
086	Separate brake supply	M	M	M	M	M	M	M	M	M
087	Brake with reduced torque, torque range 60%-33% of nominal torque.	NA	P	P	P	P	P	P	P	p
088	Hand release	M	S	S	S	S	S	S	S	S
213	Brake with increased degree of protection. Rubber ring and V-ring for IP55 protection.	M	M	M	M	M	M	M	M	M
285	Reconnection of brake for separate dc supply at 24 V.	R	M	M	M	M	M	M	M	M
288	Brake motor with voltage code S for the motor and separate supply of the brake for voltage corresponding to code D.	R	M	M	M	M	M	M	M	M
289	Brake motor with voltage code D for the motor and separate supply of the brake for voltage corresponding to code S.	R	M	M	M	M	M	M	M	M
290	Brake motor with a.c. brake, change into d.c. brake keeping the voltage code.	R	M	M	M	M	M	M	M	M
291	Brake motor with d.c. brake, change into a.c. brake keeping the voltage code.	R	M	M	M	M	M	M	M	M
<b>Special voltage</b>										
209	Non-standard voltage or frequency (special winding) Different brake coil (e.g. 25 Vdc), max. 500 Vac.	R	R	R	P	P	P	P	P	P
<b>Protection</b>										
005	Protective roof, for vertical mounting with shaft end downwards.	M	M	M	M	M	M	M	M	M

For other variant codes please see section for standard aluminium motors or consult ABB.

- S** = Included as standard
- P** = New manufacture only.
- M** = On modification of a stocked motor or on new manufacture, the number per order may be limited.
- R** = On request.
- NA** = Not applicable.

## Brake rating plates

The brake rating plates have the following arrangement:

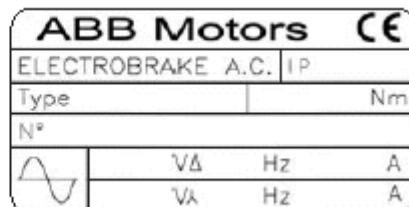
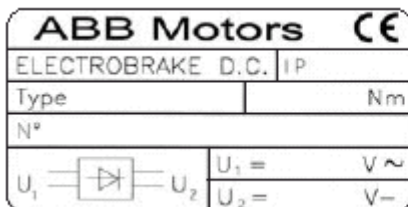

# General purpose brake motors

# Sizes 63-180

## Dimension drawings

IM B3 (IM 1001)

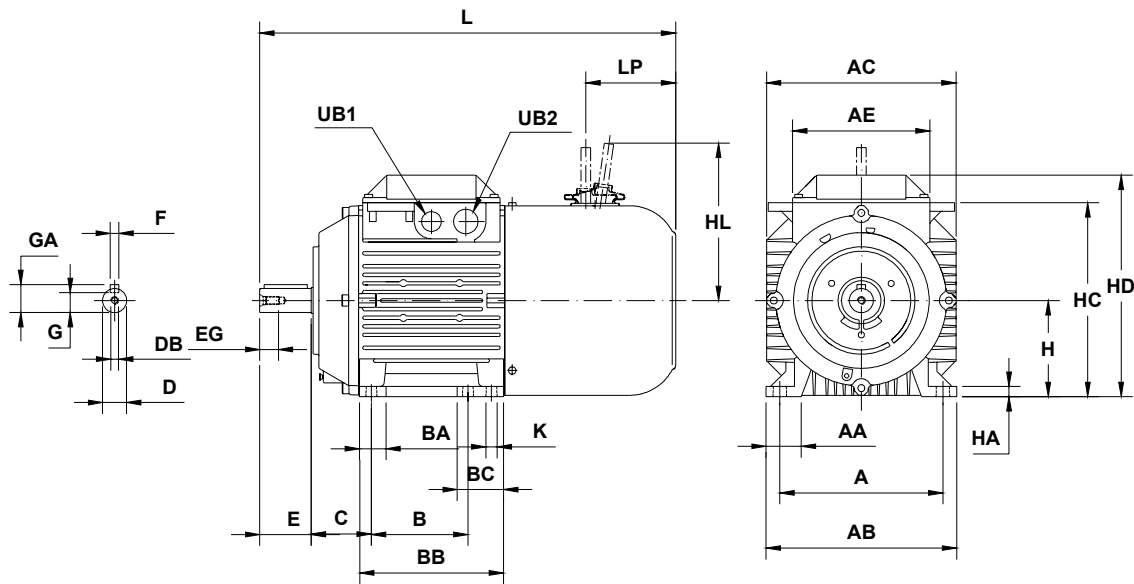

Motor size	A	AA	AB	AC	AE	B	BA	BB	BC	C	D	DB	E	EG
63 A/B	100	26	120	123	85	80	21	96	21	40	11	M4	23	10
63 MA/MB	100	35	115	123	94	80	25	96	25	40	11	M4	23	10
71	112	24	136	139	85	90	31	110	31	45	14	M5	30	13
80	125	28	154	156	97	100	34	125	34	50	19	M6	40	16
90S	140	27	170	177	110	100	30	125	30	56	24	M8	50	19
90 L	140	27	170	177	110	125	30	150	30	56	24	M8	50	19
100 L	160	32	197	197	110	140	34	172	34	63	28	M10	60	22
112 M	190	41	222	221	160	140	31	168	31	70	28	M10	60	22
132 S	216	47	262	261	160	140	40	212	76	89	38	M12	80	28
132 M	216	47	262	261	160	178	40	212	76	89	38	M12	80	28
160 M	254	56	310	314	210	210	55	287.5	86	108	42	M16	110	36
160 L	254	56	310	314	210	254	55	287.5	86	108	42	M16	110	36
180	279	65.5	340	314	210	241	91	329	91	121	48	M16	110	36

Motor size	F	GA	H	HA	HC	HD	HL	K	L	LP	UB1	UB2
63 A/B	4	12.5	63	10	-	180	107	7	270	66	M16	Pg11
63 MA/MB	4	12.5	63	6	-	188	-	7	277	-	M20	M20
71	5	16	71	9	-	176	114	7	316	76	M20	Pg16
80	6	21.5	80	10	-	190	124	10	360	70	M20	Pg16
90S	8	27	90	10	177	217	161	10	370	70	M25	M25
90 L	8	27	90	10	177	217	161	10	395	70	M25	M25
100 L	8	31	100	12	197	237	173	12	453	105	M25	M25
112 M	8	31	112	12	226	258	184	12	487	105	M20	M25
132 S	10	41	132	14	264	296	225	12	606	119	M20	M25
132 M	10	41	132	14	264	296	225	12	606	119	M20	M25
160 M	12	45	160	20	325	369	253	15	782	139	M40	M40
160 L	12	45	160	20	325	369	253	15	782	139	M40	M40
180	14	51.5	180	20	345	389	253	15	782	139	M40	M40

**Tolerances:**

- D ISO j6 ( $\leq 28 \text{ } \varnothing$ )
- D ISO k6 (38-42  $\varnothing$ )
- F ISO h9
- H + 0, - 0.5

Above table gives the main dimensions in mm.  
For detailed drawings please see our web-pages  
'[www.abb.com/motors&drives](http://www.abb.com/motors&drives)' or contact us.

# General purpose brake motors

# Sizes 63-180

## Dimension drawings

IM B5 (IM 3001), IM V1 (IM 3011), IM B14 (IM 3601)

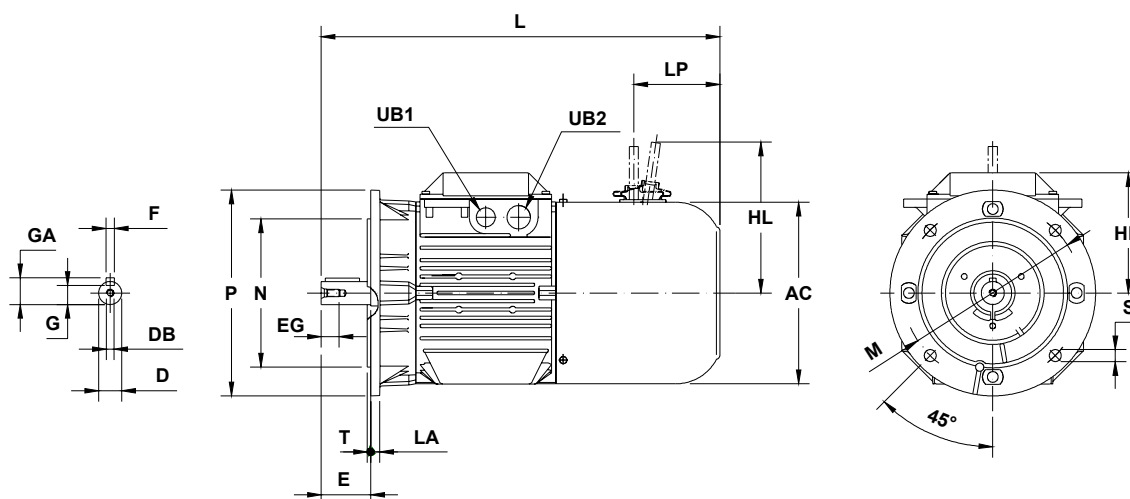

### IM B5 (IM 3001)

Motor size	AC	D	DB	E	EG	F	GA	HB	HL	L	LP	UB1	UB2
63 A/B	123	11	M4	23	10	4	12.5	117	107	270	66	M16	Pg 11
63 MA/MB	123	11	M4	23	10	4	12.5	125	—	277	—	M20	M20
71	139	14	M5	30	13	5	16	105	114	316	76	M20	Pg 16
80	156	19	M6	40	16	6	21.5	110	124	360	70	M20	Pg16
90S	178	24	M8	50	19	8	27	127	161	370	70	M25	M25
90 L	178	24	M8	50	19	8	27	127	161	395	70	M25	M25
100 L	198	28	M10	60	22	8	31	137	173	453	105	M25	M25
112 M	223	28	M10	60	22	8	31	146	184	487	105	M20	M25
132 S,M	264	38	M12	80	28	10	41	164	225	606	119	M20	M25
160 M,L	317	42	M16	110	36	12	45	209	253	782	139	M40	M40
180	317	48	M16	110	36	14	51.5	209	253	782	139	M40	M40

### IM B5 (IM 3001)

Motor size	IEC flange	LA	M	N	P	S <sup>1)</sup>	T
63 A/B	FF115	10	115	95	140	M8	3
63 MA/MB	FF115	6.5	115	95	140	M8	3
71	FF130	10	130	110	160	M8	3.5
80	FF165	12	165	130	200	M10	3.5
90	FF165	11	165	130	200	M10	3.5
100	FF215	11	215	180	250	M12	4
112	FF215	11	215	180	250	M12	4
132	FF265	12	265	230	300	M12	4
160	FF265	12	265	230	300	M12	4
160 <sup>2)</sup>	FF300	20	300	250	350	M16	5
180	FF300	20	300	250	350	M16	5

### IM B14 (IM 3601)

Motor size	IEC flange	LA	M	N	P	S	T
63 A/B	FT75	10	75	60	90	M5	2.5
63 MA/MB	FT75	10	75	60	90	M5	3
71	FT85	10	85	70	105	M6	2.5
80	FT100	10	100	80	120	M6	3
90	FT115	14	115	95	140	M8	3
100	FT130	16	130	110	160	M8	3.5
112 <sup>3)</sup>	FT130	9.5	130	110	160	M8	3.5
132	FT165	14.5	165	130	200	M8	3.5

Tolerances:

D ISO j6 ( $\leq 28 \text{ } \emptyset$ )

D ISO k6 (38-42  $\emptyset$ )

F ISO h9

<sup>1)</sup> Clearance holes for bolt.

<sup>2)</sup> Optional for frame size 160.

<sup>3)</sup> Two pieces modular flange.

Modular flanges:

Brake motors sizes 71-132 can be supplied with several non standard modular flange dimensions

Above table gives the main dimensions in mm.  
For detailed drawings please see our web-pages  
'[www.abb.com/motors&drives](http://www.abb.com/motors&drives)' or contact us.

# General purpose brake motors in brief, basic design

Motor size		63 A/B BB	63 MA/MB	71	80	90	100	112	132	160	180	
Stator and feet	Material	Die-cast aluminium alloy. Loose feet in sizes 63MA/MB-100 and 180; feet integrated with stator in sizes 63A/B, 112-160.										
	Paint colour shade Paint	Munsell blue 8B 4.5/3.25 / NCS 4822 BO5G Exoxy polyester powder paint, $\geq 30 \mu\text{m}$ .						2-pack polyurethane paint, $\geq 20\mu\text{m}$ .				
Bearing end shields	Material	Die-cast aluminium alloy.										
	Paint colour shade Paint	Munsell blue 8B 4.5/3.25 / NCS 4822 BO5G Epoxy polyester powder paint, $\geq 30 \mu\text{m}$ .						2-pack polyurethane paint, $\geq 20\mu\text{m}$				
Flanges	Material	Die-cast aluminium alloy.						Cast iron				
	Paint colour shade Paint	Munsell blue 8B 4.5/3.25 / NCS 4822 BO5G Epoxy polyester powder paint, $\geq 30 \mu\text{m}$ .						2-pack polyurethane paint, $\geq 20\mu\text{m}$				
Bearings	D-end	6202- 2Z/C3	6201-2Z	6203- 2Z/C3	6204- 2Z/C3	6205- 2Z/C3	6306- 2Z/C3	6206- 2Z/C3	6208- 2Z/C3	6309- 2Z/C3	6310- 2Z/C3	
	N-end	6202- 2Z/C3	6201-2Z	6203- 2Z/C3	6204- 2Z/C3	6205- 2Z/C3	6206- 2Z/C3	6206- 2Z/C3	6208- 2Z/C3	6209- 2Z/C3	6209- 2Z/C3	
Axially locked bearings	System	Inner bearing circlip, on request. In sizes 71-80 mounting large flange.				Inner bearing cover at D-end.						
Bearing seals	D-end	V-ring	Radial seal	V-ring								
	N-end	V-ring	-	V-ring								
Lubrication		Permanently lubricated bearings. Grease for bearing temperatures $-40\dots+160^\circ\text{C}$ .										
Terminal box	Material Surface treatment Srews	Die-cast aluminium alloy. Similar to stator. Steel 5 G, chromated.										
Connections	Knock-out openings	1 x M16 + Pg11	2xM20 +1xM12	2xM20 + Pg16		4 x M25		2 x(M25 + M20)		2 x (M40 + M16)		
	Max Cu area, mm <sup>2</sup>	2.5		4		6		10		35		
	Terminal box	Screw terminal, 6 terminals.						Cable lugs, 6 terminals.				
Fan	Material	Polypropylene. Reinforced with 20% glass fibre.										
Fan cover	Material	Steel.										
Stator winding	Material Impregnation Insulation class	Copper. Polyester varnish. Tropicallised. Insulation class F. Temperature rise class B, unless otherwise stated.										
Stator winding temperature sensors		Optional.										
Rotor winding	Material	Die-cast aluminium.										
Balancing method		Half key balancing.										
Key way		Closed key way.										
Enclosure		Motor, terminal box and brake electrical components: IP 55. Brake mechanical components: IP23 S (IP 55 optional).										
Cooling method		IC 411.										
Drain holes		Standard, except in frame size 63 MA/MB.										



# Drive<sup>IT</sup> Single Phase Motors

Totally enclosed squirrel cage single phase low voltage motors,  
Sizes 56 - 100, 0.065 to 2.2 kW

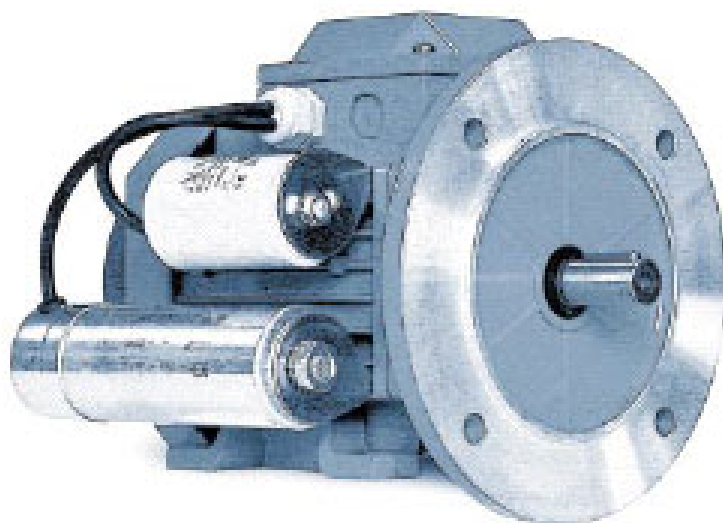

<b>Mechanical design.....</b>	<b>192</b>
<b>Ordering information.....</b>	<b>198</b>
<b>Technical data.....</b>	<b>199</b>
<b>Rating plates.....</b>	<b>201</b>
<b>Variant codes.....</b>	<b>202</b>
<b>Dimension drawings.....</b>	<b>205</b>
<b>Single phase motors in brief.....</b>	<b>207</b>

In many respects single phase motors have the same properties as three phase motors, and mechanically they meet the same standards. There are several types of single phase motors (CSR, PSC and PSC-reg.). Each

type has its benefits and limitations, as described in the section below.

Single phase motors are used in many industries and for many purposes.

## Description and application

### CSR

#### Starting and run capacitor

Single phase motor with attached run capacitor, starting capacitor and electronic start relay mounted in the terminal box.

The electronic start relay connects the starting capacitor instantly when the motor starts, and cuts out when the motor has reached its break-down torque. The connection time is limited to max. 2 sec., after which the starting capacitor is disconnected, regardless of whether the motor has reached its breakdown torque. The starter relay cannot reconnect until the mains voltage to the motor has been disconnected; this protects the starting capacitor and ensures that the motor can be protected with a thermal motor line circuit breaker.

The CSR motor with a starting torque of 140 - 160% is suitable for applications that require a high starting torque, such as compressors, hydraulic pumps that start with back pressure and centrifugal pumps where the shaft seal requires a high breakaway torque.

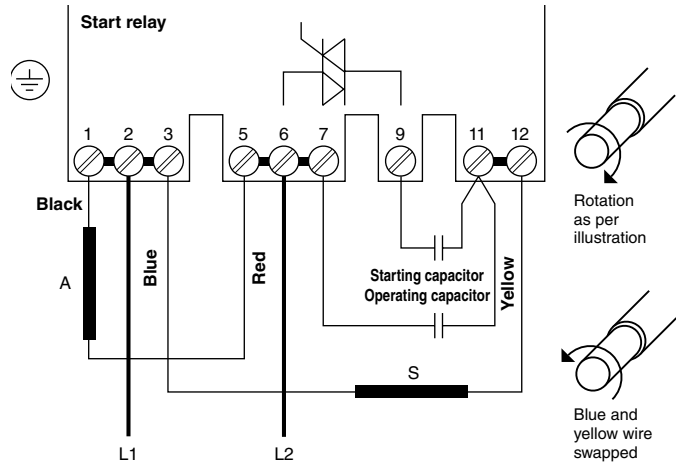

CSR model with electronic start relay.

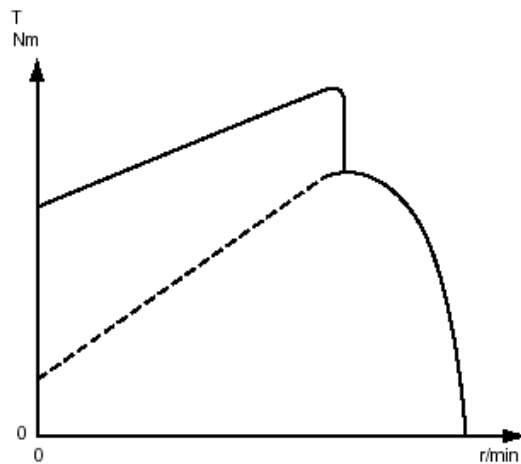

Torque curve for CSR motor.

### PSC

#### Run capacitor

Single-phase motor with attached run capacitor. The starting torque is 30 - 70%, which makes this motor particularly suitable for applications with low starting torque requirements, such as fans, circular saws, polishing machines and centrifugal pumps where the shaft seal does not require a high breakaway torque.

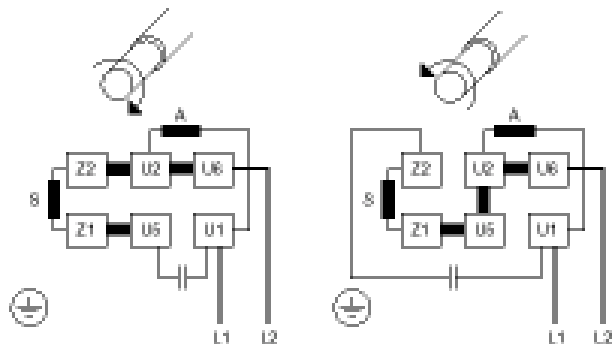

Basic PSC model.



# PSC

## for speed regulation

The motor's speed can be regulated by changing the voltage to the motor (twin-cable regulation) or by only changing the voltage to the circuit winding (three-cable regulation). The best regulation and the minimum loss in the motor is achieved only by changing the voltage to the circuit winding.

The voltage can be regulated using a transformer or a Triac control. The Triac control provides a greater loss in the motor and can contribute to noise in the motor.

To achieve good speed regulation it is important that the motor is suitable for the load. If the motor is too large for the load the regulation range will be small; at full speed the motor should not be loaded with less than 80% of its full load. With correct dimensioning it is possible to regulate speed down to approx. 30% of nominal speed.

Speed regulation is suitable for the following applications: fans where blades are mounted directly on the motor shaft and centrifugal pumps where the shaft seal does not require a high breakaway torque.

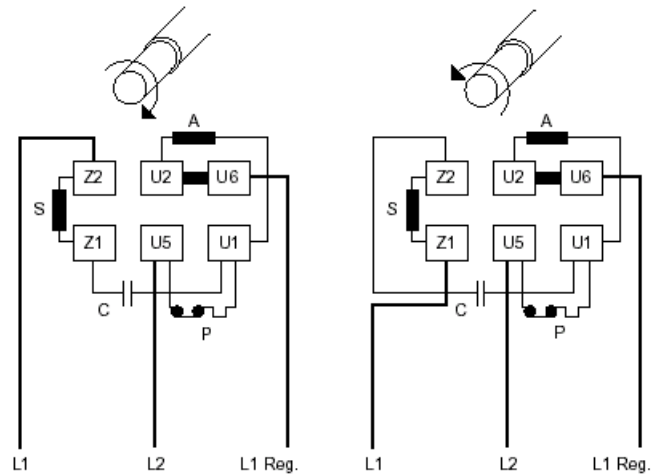

PSC model. Regulation of number of revolutions using electronic device (TRIAC).

## Reversing

As a rule a single phase motor can only reverse when it stops completely before the rotational direction is changed. In CSR motors it is also important that the capacitor is discharged before the voltage is reconnected, as otherwise the starter relay will not connect the starter capacitor.

It is possible to design a PSC motor that is suitable for reversing. The motor has a joint start and circuit winding, which provides for very simple switching.

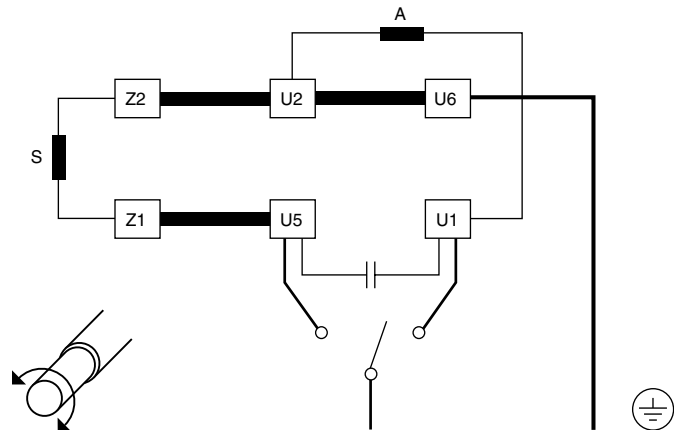

## No load

Standard single phase motors cannot run idle for a long period. The losses are greater when running idle than at full load. If the motor is to run idle for a long period, specially designed windings must be produced.

# Mechanical design

## Stator

Stator framework, bearing shields and feet are made of aluminium alloy with low copper content.

## Drain holes

Motors that will be operated in very humid or wet environments, and especially under intermittent duty, should be provided with drain holes. The appropriate IM designation, such as IM 3031, is specified on the basis of the method of mounting the motor.

In the basic design motors are supplied with drain holes as standard (see diagram below) on both D-end and N-end.

When mounting the motors, it should be ensured that the drain hole faces downwards. In the case of vertical mounting, the upper plug must be hammered home. In very dusty environments both plugs should be hammered home.

See variant codes 065 and 066 under the heading "Drain holes".

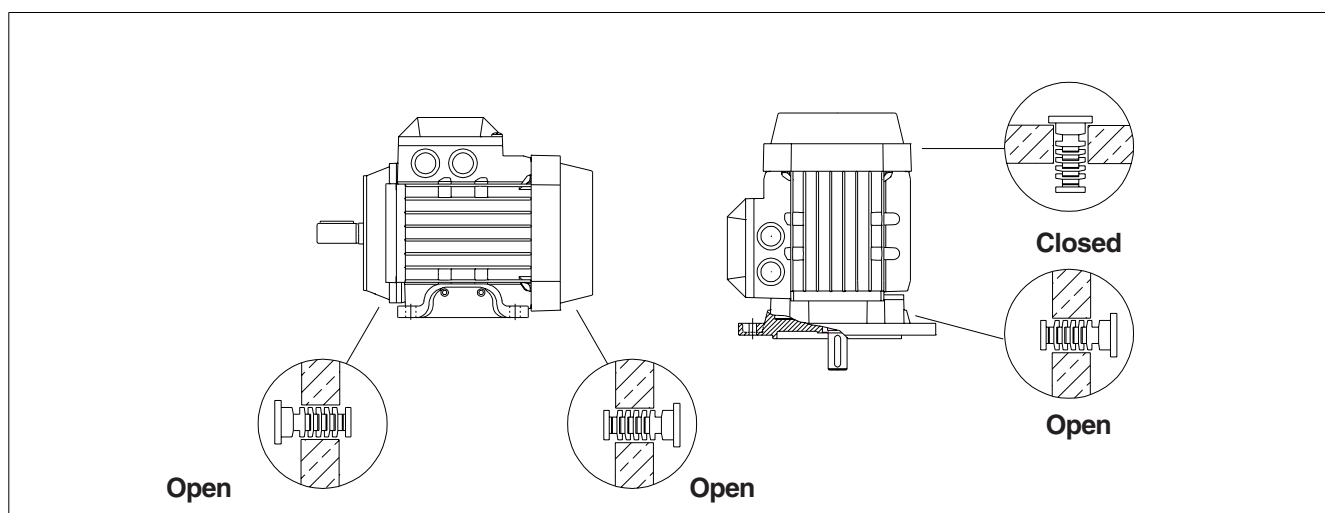

# Terminal box and connections

## Terminal box for sizes 56 to 63

The terminal box is made of aluminium and is located on top of the stator as standard. It is provided with two knockout openings (one Pg and one metric) and can be turned 4x90°.

Cable glands are not included. The size of the box is the same in size 56 and 63.

### Position of terminal box

Motor size	Terminal box		
	on top	right side	left side
56-63	standard	–	–
71-100	standard	on request	on request

### Terminal box examples

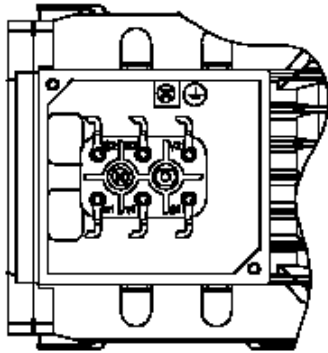

Motor sizes 56-80.

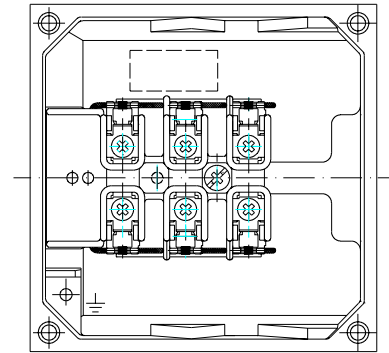

Motor sizes 90-100.

## Terminal box for sizes 71 to 100

The terminal box is made of aluminium and is located either on the top of the motor, or on either side of the motor. The lower part of the box is integrated with the stator and allows cable entries from both sides.

It is provided with two knockout openings on each side. Cable glands are not included.

Degree of protection of standard terminal box is IP 55.

## Connections

The terminal block is provided with 6 terminals for connecting Cu-cable. The terminals are marked in accordance with IEC 60034-8.

### Connection openings

Motor size	Opening	Metric cable entry	Cable diameter, mm, min-max	Terminal bolt size	Maximum connectable Cu-cable area, mm <sup>2</sup>
56-63	Knock-out opening	1 x M16 x 1.5; 1 x Pg 11	5-12	M4	2.5
71-80	Knock-out opening	2 x M20 x 1.5; 1 x Pg 16	8-15	M4	4
90-100	Knock-out opening	4 x M25 x 1.5	11-16	M4	2.5 (for PCS) or 1.5 (for CSR)

# Bearings

The motors are provided with bearings, according to the tables on the right.

Motor size	Standard bearing type	
	D-end	N-end
56	6201-2Z/C3	6201-2Z/C3
63	6202-2Z/C3	6201-2Z/C3
71	6203-2Z/C3	6202-2Z/C3
80	6204-2Z/C3	6203-2Z/C3
90	6205-2Z/C3	6204-2Z/C3
100	6306-2Z/C3	6205-2Z/C3

## Axially-locked bearings

The table on the right shows which of the motor's bearings is axially locked in the bearing seat. In motor sizes 56 to 80 the locking is done by an inner bearing circlip, in motor sizes 90 and 100 by an inner bearing cover.

Motor size	Foot-mounted motors	Flange-mounted motors	
		Large flange	Small flange
56-63	On request	On request	On request
71-80	On request	D-end	On request
90-100	D-end <sup>1)</sup>	D-end <sup>1)</sup>	D-end <sup>1)</sup>

<sup>1)</sup> A spring washer at N-end presses the rotor towards D-end.

## Lifetime of bearing/grease

The motors are supplied with bearings that are lubricated for life with a bearing grease for use at normal temperatures in dry or humid environments.

The grease's operating temperature is between -40 and +160°C. See also variant code 039 under the heading "Bearings and Lubrication".

The life time of the grease L10 is defined as the number of operating hours after which 90% of the bearings are sufficiently well lubricated. 50% of the bearings can achieve a grease life time that is twice as long.

The maximum life time of the grease should, however, be considered to be 40,000 hours, equivalent to around 5 years.

Motor size	No. of poles	Hours
56-80	2-6	40.000
90	2	30.000
90	4-6	40.000
100	2	28.000
100	4-6	40.000

# 7

## Pulley diameter

When the desired bearing life has been determined, the minimum permissible pulley diameter can be calculated with FR, according to the formula:

$$D = \frac{1.9 \cdot 10^7 \cdot K \cdot P}{n \cdot FR}$$

Where:

D = diameter of pulley, mm

P = power requirement, kW

n = motor speed, r/min

K = belt tension factor, dependent on belt type and type of duty. A common value for V belts is K= 2.5

FR = permissible radial force

# Permissible loading on shaft

The table below shows the permitted radial force in Newtons at zero axial force.

The permitted load of combined radial and axial force is available on request.

The bearing's life time,  $L_{10}$ , is calculated according to SKF's new theory on the life time of bearings,  $L_{10aah}$ , which also takes into account the purity of the grease.

If the radial force is applied between points  $X_0$  and  $X_{max}$ , the permissible force  $F_R$  can be calculated from the following formula:

$$F_R = F_{X0} - \frac{X}{E} (F_{X0} - F_{Xmax})$$

E = length of shaft extension in basic version

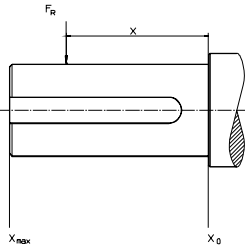

# Permissible radial forces

Motor size	No. of poles	Length of shaft extension E (mm)	Ball bearings			
			Basic design with deep groove ball bearings			
			25,000 hours		40,000 hours	
$X_0$ (N)	$X_{max}$ (N)	$X_0$ (N)	$X_{max}$ (N)			
56	2-4	30	240	200	260	200
63	2-4	30	490	400	490	400
71	2-6	30	680	570	680	570
80	2-6	40	930	750	930	750
90	2-6	50	1010	810	1010	810
100	2-6	60	2280	1800	2280	1800

# Permissible axial forces

The following tables give the permissible axial forces in Newton, assuming zero radial force.

The permitted load of combined radial and axial force is available on request.

## Mounting arrangement IM B3

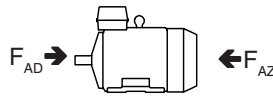

Motor size	25,000 hours						40,000 hours					
	2-pole		4-pole		6-pole		2-pole		4-pole		6-pole	
	$F_{AD}$ (N)	$F_{AZ}$ (N)	$F_{AD}$ (N)	$F_{AZ}$ (N)	$F_{AD}$ (N)	$F_{AZ}$ (N)	$F_{AD}$ (N)	$F_{AZ}$ (N)	$F_{AD}$ (N)	$F_{AZ}$ (N)	$F_{AD}$ (N)	$F_{AZ}$ (N)
56												
63	790	390	865	465			720	320	780	380		
71	985	485	1070	570	1135	635	900	400	970	470	1020	520
80	1305	705	1420	820	1505	905	1185	585	1285	685	1350	750
90	1360	930	1490	1070	1590	1165	1225	800	1335	915	1415	990
100	2805	1945	3075	2215	3260	2400	2540	1680	2760	1900	2910	2050

## Mounting arrangement IM V1

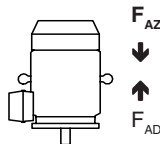

Motor size	25,000 hours						40,000 hours					
	2-pole		4-pole		6-pole		2-pole		4-pole		6-pole	
	$F_{AD}$ (N)	$F_{AZ}$ (N)	$F_{AD}$ (N)	$F_{AZ}$ (N)	$F_{AD}$ (N)	$F_{AZ}$ (N)	$F_{AD}$ (N)	$F_{AZ}$ (N)	$F_{AD}$ (N)	$F_{AZ}$ (N)	$F_{AD}$ (N)	$F_{AZ}$ (N)
56												
63	790	380	875	455			725	310	790	370		
71	998	470	1085	555	1150	620	910	385	985	455	1035	505
80	1320	685	1445	790	1530	880	1200	565	1310	655	1375	725
90	1390	900	1525	1035	1625	1130	1225	770	1370	880	1450	955
100	2855	1890	3135	2155	3320	2340	2590	1625	2820	1840	2970	1990

# Ordering information

## Sample order

When placing an order, please state the following minimum data in the order, as in the example.

The product code of the motor is composed in accordance with the following example.

Motor type	M3VD 80C
Pole number	2
Mounting arrangement (IM-code)	IM B3 (IM 1001)
Rated output	1.4 kW
Product code	3GVD 081003-ASB
Variant codes if needed	

A	B	C	D, E, F	G	A	Motor type
M3VD	80	C	3GVD 081 003 - ASB, 122, 053, etc.		B	Motor size
					C	Product code
					D	Mounting arrangement code
					E	Voltage/frequency code
					F	Generation code
					G	Variant codes

## Explanation of the product code

### Positions 1 and 2

**3G** = Business area LV Motors

### Position 3 and 4

Enclosure and stator frame material

**A, V** = Totally enclosed motor with aluminium stator frame

### Position 4

Motor type

**D** = Single-phase motor - CSR

**E** = Single-phase motor - PSC

### Positions 5 and 6

IEC size

**05** = 56

**06** = 63

**07** = 71

**08** = 80

**09** = 90

**10** = 100

### Position 7

Speed (pole pairs)

**1** = 2 poles

**2** = 4 poles

**3** = 6 poles

### Positions 8 to 10

Serial number

### Position 11

- (dash)

### Position 12

Mounting arrangement

**A** = Foot-mounted motor.

**B** = Flange-mounted motor.

Large flange with clearance holes.

**C** = Flange-mounted motor.

Small flange with threaded holes.

**H** = Foot- and flange-mounted motor.

Large flange with clearance holes.

**J** = Foot- and flange-mounted motor.

Small flange with threaded holes.

**N** = Flange-mounted (CI ring flange FF).

**P** = Foot- and flange-mounted motor.

(CI ring flange FF).

**V** = Flange-mounted motor. Special flange.

### Position 13

Voltage/frequency code

**S** = 230-240 V 50 Hz.

**X** = Other rated voltage, connection or frequency.

### Position 14

**B, E** = Generation code

The product code must be, if needed, followed by variant codes.

# General purpose single phase motors

CSR motors, starting torque approx. 140-160 %

IP 55 – IC 411 – Insulation class F, temperature rise class B

Output kW	Type designation	Product code	Speed r/min	Efficiency %	Power factor cos φ	Current		Torque			Capacitor		Moment of inertia J=1/4 GD <sup>2</sup> kgm <sup>2</sup>	Weight kg
						I <sub>N</sub> A	I <sub>s</sub> A	T <sub>N</sub> Nm	T <sub>s</sub> Nm	T <sub>max</sub> Nm	Start μF	Run μF		
<b>3000 r/min = 2 poles</b>														
<b>230 V 50 Hz</b>														
0.18	M3VD 63 A	3GVD 061 001-••B	2820	56.5	0.92	1.6	3.3	0.61	2.0	2.0	16	8	0.000160	5
0.25	M3VD 63 B	3GVD 061 002-••B	2820	60.5	0.94	1.95	3.6	0.85	2.0	2.1	20	10	0.000360	5.5
0.37	M3VD 71 A	3GVD 071 001-••B	2855	71.5	0.99	2.3	4.8	1.25	1.7	1.8	40	10	0.000400	6
0.55	M3VD 71 B	3GVD 071 002-••B	2860	72.5	0.99	3.4	4.8	1.85	1.7	1.8	60	16	0.000450	7
0.75	M3VD 71 C	3GVD 071 003-••B	2860	74.5	0.99	4.4	4.9	2.5	1.7	1.8	60	20	0.000500	7.5
0.75	M3VD 80 A	3GVD 081 001-••B	2860	73.0	0.99	4.4	4.6	2.0	1.8	2.2	80	20	0.000722	9.5
1.10	M3VD 80 B	3GVD 081 002-••B	2860	74.5	0.99	6.5	4.6	3.7	1.7	2.1	100	25	0.000763	11.5
1.4 <sup>1)</sup>	M3VD 80 C	3GVD 081 003-••B	2860	75.5	0.99	8.2	4.8	4.7	1.7	2.0	100	30	0.001093	12
1.5	M3AD 90 L	3GAD 091 202-••E	2910	80.0	0.99	8.2	4.6	5.0	1.4	1.9	130	40	0.00190	13
2.2	M3AD 90 LB	3GAD 091 203-••E	2910	81.5	0.99	11.8	4.2	7.3	1.1	1.8	130	50	0.00240	16
<b>1500 r/min = 4 poles</b>														
<b>230 V 50 Hz</b>														
0.12	M3VD 63 A	3GVD 062 001-••B	1350	49.5	0.95	1.2	3.0	0.85	1.6	1.5	16	4	0.000260	5
0.18	M3VD 63 B	3GVD 062 002-••B	1360	55.0	0.97	1.5	3.0	1.25	1.6	1.5	20	6	0.000300	5.5
0.25	M3VD 71 A	3GVD 072 001-••B	1410	64.0	0.99	1.75	4.3	1.7	1.7	1.6	40	6	0.000660	6
0.37	M3VD 71 B	3GVD 072 002-••B	1410	67.5	0.98	2.45	4.5	2.5	1.7	1.6	60	8	0.000890	7
0.5	M3VD 71 C	3GVD 072 003-••B	1410	68.5	0.98	3.2	4.5	3.4	1.7	1.6	60	12	0.001100	7.5
0.55	M3VD 80 A	3GVD 082 001-••B	1410	70.5	0.93	3.7	4.0	3.7	1.9	1.8	60	16	0.001257	9.5
0.75	M3VD 80 B	3GVD 082 002-••B	1410	72.0	0.93	4.9	4.1	5.1	2.0	1.8	80	20	0.001565	11
0.95	M3VD 80 C	3GVD 082 003-••B	1410	73.0	0.93	6.1	4.1	6.1	1.8	1.8	80	16	0.001948	11.5
1.1	M3AD 90 S	3GAD 092 201-••E	1420	76.0	0.99	6.3	4.0	7.35	1.6	1.5	100	30	0.00320	13
1.5	M3AD 90 L	3GAD 092 202-••E	1430	79.5	0.99	8.3	4.3	10.0	1.9	1.7	130	40	0.00430	16
1.7	M3AD 90 LB	3GAD 092 203-••E	1430	79.5	0.99	9.4	3.4	11.5	1.3	1.6	130	60	0.00480	17
1.85	M3AD 100 LA	3GAD 102 201-••E	1390	76.5	0.99	10.6	3.0	12.7	1.3	1.4	100	50	0.00690	21
2.2	M3AD 100 LB	3GAD 102 202-••E	1400	79.5	0.99	12	3.2	15	1.2	1.5	80	50	0.00820	24
<b>1000 r/min = 6 poles</b>														
<b>230 V 50 Hz</b>														
0.18	M3VD 71 A	3GVD 073 001-••B	880	52.0	0.99	1.5	2.8	1.95	1.5	1.3	20	10	0.000630	6
0.25	M3VD 71 B	3GVD 073 002-••B	880	59.0	0.99	1.9	3.0	2.7	1.5	1.3	40	12	0.000810	7
0.32	M3VD 71 C	3GVD 073 003-••B	880	61.0	0.99	2.3	3.0	3.5	1.5	1.3	40	16	0.001100	7.5
0.37	M3VD 80 A	3GVD 083 001-••B	900	65.0	0.97	2.6	3.0	3.9	1.8	1.5	40	12	0.001842	9.5
0.55	M3VD 80 B	3GVD 083 002-••B	900	66.0	0.97	3.8	3.1	5.8	1.8	1.5	40	20	0.002176	10.5
0.65 <sup>1)</sup>	M3VD 80 C	3GVD 083 003-••B	900	67.5	0.97	4.3	3.2	6.9	1.8	1.5	60	25	0.002576	11.5
0.85	M3AD 90 L	3GAD 093 202-••E	930	71.0	0.96	5.4	3.9	8.65	1.7	1.4	80	25	0.00430	16

<sup>1)</sup> Temperature rise class F.

The bullets in the product code indicate choice of mounting arrangement, voltage and frequency, generation code (see ordering information page).

# General purpose single phase motors

## PSC motors, starting torque 30-70 %

IP 55 – IC 411 – Insulation class F, temperature rise class B

Output kW	Type designation	Product code	Speed r/min	Efficiency %	Power factor cos φ	Current		Torque			Capacitor Run μF	Moment of inertia J=1/4 GD <sup>2</sup> kgm <sup>2</sup>	Weight kg												
						I <sub>N</sub> A	I <sub>s</sub> A	T <sub>N</sub> Nm	T <sub>s</sub> Nm	T <sub>max</sub> Nm															
<b>3000 r/min = 2 poles</b>													<b>230 V 50 Hz</b>												
0.065	M3VE 56 A	3GVE 051 001-••B	2830	39.0	0.86	0.87	2.5	0.22	0.4	1.9	4	0.000110	3.5												
0.09	M3VE 56 B	3GVE 051 002-••B	2820	43.0	0.84	1.15	2.6	0.31	0.35	1.8	4	0.000120	4												
0.12	M3VE 56 BB	3GVE 051 003-••B	2800	48.0	0.95	1.15	2.5	0.41	0.4	1.3	6	0.000120	4												
0.18	M3VE 63 A	3GVE 061 001-••B	2820	55.0	0.90	1.6	2.9	0.61	0.5	1.9	8	0.000160	5												
0.25	M3VE 63 B	3GVE 061 002-••B	2810	59.5	0.94	1.95	3.0	0.85	0.6	1.8	10	0.000360	5.5												
0.37	M3VE 71 A	3GVE 071 001-••B	2750	65.5	0.97	2.6	3.0	1.3	0.6	1.7	12	0.000400	6												
0.55	M3VE 71 B	3GVE 071 002-••B	2750	67.5	0.97	3.7	3.0	1.95	0.6	1.7	16	0.000450	7												
0.65 <sup>1)</sup>	M3VE 71 C	3GVE 071 003-••B	2750	68.5	0.97	4.3	3.2	2.25	0.6	1.7	20	0.000500	7.5												
0.75	M3VE 80 A	3GVE 081 001-••B	2760	68.5	0.96	5.0	3.5	2.6	0.4	1.6	20	0.000722	9.5												
0.9	M3VE 80 B	3GVE 081 002-••B	2775	70.5	0.96	5.8	3.7	3.1	0.45	1.6	25	0.000763	11.5												
1.1 <sup>1)</sup>	M3VE 80 C	3GVE 081 003-••B	2800	72.0	0.97	7.4	3.9	3.75	0.4	1.7	30	0.001093	12												
1.5	M3AE 90 L	3GAE 091 102-••E	2850	76.5	0.99	8.7	4.2	5.1	0.4	2.0	40	0.00240	16												
<b>1500 r/min = 4 poles</b>													<b>230 V 50 Hz</b>												
0.065	M3VE 56 A	3GVE 052 001-••B	1360	38.0	0.87	0.9	2.0	0.46	1.1	1.6	4	0.000180	4												
0.09	M3VE 56 B	3GVE 052 002-••B	1340	39.0	0.95	1.1	1.8	0.64	1.0	1.5	6	0.000180	4												
0.12	M3VE 63 A	3GVE 062 001-••B	1350	48.5	0.92	1.2	1.9	0.85	0.65	1.5	6	0.000260	5												
0.18	M3VE 63 B	3GVE 062 002-••B	1360	55.0	0.95	1.5	1.9	1.25	0.6	1.5	8	0.000300	5.5												
0.25	M3VE 71 A	3GVE 072 001-••B	1350	57.5	0.95	2.0	2.6	1.8	0.6	1.5	12	0.000660	6												
0.3	M3VE 71 B	3GVE 072 002-••B	1360	62.0	0.95	2.2	2.7	2.1	0.65	1.5	16	0.000890	7												
0.37	M3VE 71 C	3GVE 072 003-••B	1370	64.0	0.95	2.7	3.1	2.6	0.7	1.6	20	0.001100	7.5												
0.55	M3VE 80 A	3GVE 082 001-••B	1340	64.0	0.91	4.1	3.3	3.85	0.55	1.6	16	0.001257	9.5												
0.65	M3VE 80 B	3GVE 082 002-••B	1360	67.0	0.91	4.7	3.3	4.6	0.6	1.6	20	0.001565	11												
0.75	M3VE 80 C	3GVE 082 003-••B	1410	68.0	0.92	5.2	3.6	4.9	0.45	1.7	30	0.001948	11.5												
1.3	M3AE 90 L	3GAE 092 102-••E	1330	72.0	0.99	7.9	2.3	9.3	0.4	1.3	30	0.00430	16												
1.5	M3AE 90 LB	3GAE 092 103-••E	1340	73.0	0.99	9.0	2.3	10.6	0.4	1.3	40	0.00480	17												
1.85	M3AE 100 LA	3GAE 102 101-••E	1380	75.5	0.99	10.7	2.6	12.8	0.3	1.3	50	0.00690	21												
2.2	M3AE 100 LB	3GAE 102 102-••E	1400	78.5	0.99	12.2	3.1	14.9	0.3	1.6	50	0.00820	24												
<b>1000 r/min = 6 poles</b>													<b>230 V 50 Hz</b>												
0.12	M3VE 71 A	3GVE 073 001-••B	850	45.0	0.96	1.25	1.8	1.35	0.75	1.3	8	0.000630	6												
0.18	M3VE 71 B	3GVE 073 002-••B	860	48.0	0.96	1.7	1.9	2.1	0.8	1.4	10	0.000810	7												
0.25	M3VE 71 C	3GVE 073 003-••B	860	51.5	0.96	2.2	1.9	2.8	0.8	1.4	12	0.001100	7.5												
0.30	M3VE 80 A	3GVE 083 001-••B	900	56.5	0.91	2.5	2.5	3.2	0.65	1.5	12	0.001842	9.5												
0.37	M3VE 80 B	3GVE 083 002-••B	900	58.5	0.92	3.0	2.5	3.9	0.65	1.5	12	0.002176	10.5												
0.55 <sup>1)</sup>	M3VE 80 C	3GVE 083 003-••B	880	59.5	0.90	4.5	2.5	6	0.7	1.4	16	0.002576	11.5												
0.75	M3AE 90 L	3GAE 093 102-••E	850	64.5	0.99	5.1	1.8	8.35	0.5	1.1	30	0.00430	16												

<sup>1)</sup> Temperature rise class F.

The bullets in the product code indicate choice of mounting arrangement, voltage and frequency, generation code (see ordering information page).



# General purpose single phase motors

## PSC motors for speed regulation

IP 55 – IC 411 – Insulation class F, temperature rise class B

Output kW	Type designation	Product code	Speed r/min	Efficiency %	Power factor cos φ	Current		Torque		Capasitor Run μF	Moment of inertia J=1/4 GD <sup>2</sup> kgm <sup>2</sup>	Weight kg
						I <sub>N</sub> A	I <sub>s</sub> A	T <sub>N</sub> Nm	T <sub>s</sub> Nm			
<b>1500 r/min = 4 poles</b>			<b>230 V 50 Hz</b>									
0.7	M3AE 90 S	3GAE 092 201-••E	1360	71.0	0.99	4.4	2.3	4.9	0.5	25	0.00320	13
0.9	M3AE 90 L	3GAE 092 202-••E	1370	73.5	0.99	5.4	2.3	6.3	0.4	30	0.00430	16
<b>1000 r/min = 6 poles</b>			<b>230 V 50 Hz</b>									
0.75	M3AE 90 L	3GAE 093 202-••E	850	64.5	0.99	5.1	1.8	8.35	0.5	30	0.00430	16

<sup>1)</sup> Temperature rise class F.

The bullets in the product code indicate choice of mounting arrangement, voltage and frequency, generation code (see ordering information page).

## Rating plate

The standard rating plates is in aluminium. Rating plate is available in stainless steel, see variant code 098.

### Motor sizes 56 to 71

ABB Motors		CE	
CL.F IP55 IEC 34	S2-15'		
Motor 1 ~ M3VE071B-6			
2100702-V			
KW 0.15	cos φ 0.99		
V 230 - 240	A 2.3		
r/min 930	Hz 50	Kg	
μF C RUN 20	/V 450		

### Motor sizes 90 to 100

ABB Motors		CE	
3-Motor M3AD 090 L	CL.F	IP 55	IEC 60034-1
3GAD092202-ASE			
N°.			
V	Hz	r/min	kw
230-240	50	1410	1.50
			A
			8.60
			0.99
IM1081 CSR			
C RUN 40μF/400V		C START 130μF/330V	16 kg

### Motor size 80

ABB Motors		CE	
Motor 1 CL.F IP55 IEC 34-1			
M3VE80C-4		1978314-V	
520000003105	Kw. 0.55	cos φ 0.95	
V 230 - 240	3.90 A	r/min 1365	Hz 50
μF C RUN 20	V 450	Kg	

# General purpose single phase motors – Variant codes

Code 1)	Variant	Motor size		
		56-63	71-80	90-100
<b>Balancing</b>				
052	Balancing to grade R (IEC 60034-14).	P	P	P
423	Balancing without key.	P	P	P
424	Balancing with full key.	P	P	P
<b>Bearings and lubrication</b>				
036	Transport lock for bearings.	NA	NA	M
037	Roller bearing at D-end. Transport lock included.	NA	NA	M
039	Cold resistant grease. For bearing temperatures -55...+100°C.	M	M	M
040	Heat resistant grease. For bearing temperatures -25...+150°C. Mandatory for ambient temperatures > 50°C.	M	M	M
041	Bearings regreasable via grease nipples.	NA	NA	M
042	Internal bearing cover, locked at D-end.	NA	M	M
057	2RS bearings at both ends. Grease for bearing temperatures -20...+110°C.	M	M	M
058	Angular contact ball bearing at D-end, shaft force away from bearing. Transport lock included.	NA	NA	M
059	Angular contact ball bearing at D-end, shaft force away towards bearing. Transport lock included.	NA	NA	M
188	63-series bearings.	NA	NA	M
<b>Branch standard design</b>				
079	Silumin-alloy rotor cage.	NA	P	P
178	Stainless steel/acid proof bolts	M	M	M
209	Non-standard voltage or frequency (special winding)	P	P	P
217	Cast iron D-end shield.	NA	NA	M
425	Corrosion protected stator and rotor core.	P	P	M
<b>Cooling system</b>				
068	Metal fan.	NA	M	M
075	Cooling method IC 418 (without fan).	P	P	P
183	Separate motor cooling (fan axial, N-end).	NA	M	R
<b>Dimension drawing</b>				
141	Binding dimension drawing.	M	M	M
<b>Drain holes</b>				
066	Modified drain hole position.	M	M	M
<b>Earthing bolt</b>				
067	External earthing bolt. Earthing screw for connection of external protective earth.	M	M	M
<b>Heating elements</b>				
450	Heating element 100-120 V.	M	M	M
451	Heating element 200-240 V.	M	M	M

1) Certain variant codes cannot be used simultaneously.

S = Included as standard.  
M = On modification of a stocked motor, or on new manufacture, the number per order may be limited.

P = New manufacture only.  
R = On request.  
NA = Not available.

Code 1)	Variant	Motor size		
		56-63	71-80	90-100
<b>Insulation systems</b>				
014	Winding insulation class H (PSC-motors only).	P	P	P
<b>Mounting arrangements</b>				
008	IM 2101 foot/flange mounted, from IM 1001 (B34 from B3).	M	M	M
009	IM 2001 foot/flange mounted, from IM 1001 (B35 from B3).	M	M	M
047	IM 3601 flange mounted, IEC flange, from IM 3001 (B14 from B5).	M	M	M
048	IM 3001 flange mounted, IEC flange, from IM 3601 (B5 from B14).	M	M	M
078	IM 3601 flange-mounted, DIN C flange. Large flange with tapped holes. Larger flange than standard version.	NA	P	NA
080	IM 3001 flange-mounted, DIN A flange. Large flange with clearance holes. Larger flange than standard version.	NA	P	NA
200	Flange ring holder.	NA	P	M
218	Flange ring FT 85.	NA	P	M (only 90)
219	Flange ring FT 100.	NA	P	M (only 90)
220	Flange ring FF 100.	NA	P	M (only 90)
223	Flange ring FT 115.	NA	P	M (only 90)
224	Flange ring FF 115.	NA	P	M (only 90)
226	Flange ring FT 135.	NA	P	M
227	Flange ring FF 135.	NA	P	M
233	Flange ring FT 165.	NA	P	M
234	Flange ring FF 165.	NA	P	M
243	Flange ring FT 215.	NA	NA	M (only 100)
244	Flange ring FF 215.	NA	NA	M (only 100)
<b>Painting</b>				
114	Special paint colour, standard grade	M	M	M
179	Special paint specification.	NA	NA	R
<b>Protection</b>				
005	Protective roof, vertical motor, shaft down.	M	M	M
072	Radial seal at D-end.	P	P	M
073	Sealed against oil at D-end.	P	P	NA
158	Degree of protection IP 65.	M	M	P
211	Weather protected, IP xx W.	NA	NA	P
403	Degree of protection IP 56. Water from waves which splash over must not enter in serious quantities.	P	P	P
<b>Rating &amp; instruction plates</b>				
002	Restamping voltage, frequency and output, continuous duty.	M	M	M
003	Individual serial number.	P	P	M
098	Stainless rating plate.	M	M	M
138	Mounting of additional identification plate.	M	M	M
139	Additional identification plate delivered loose.	M	M	M
161	Additional rating plate delivered loose.	M	M	M

1) Certain variant codes cannot be used simultaneously.

S = Included as standard.

M = On modification of a stocked motor, or on new manufacture, the number per order may be limited.

P = New manufacture only.

R = On request.

NA = Not available.

Code 1)	Variant	Motor size		
		56-63	71-80	90-100
<b>Shaft and rotor</b>				
069	Two shaft extensions as per basic catalogue. Standard shaft material.	P	P	P
070	One or two special shaft extensions, standard shaft material.	P	P	P
165	Shaft extension with open key-way.	P	P	P
410	Stainless/acid-proof steel shaft, standard or non-standard design. One or two shaft extensions.	P	P	P
<b>Standards and regulations</b>				
010	Fulfilling CSA Safety Certificate.	P	P	P
029	Fulfilling Underwriters Laboratory (UL) requirements.	NA	NA	P
<b>Stator winding temperature sensors</b>				
121	Bimetal detectors, break type (NCC), (3 in series), 130°C, in stator winding.	M	M	R
122	Bimetal detectors, break type (NCC), (3 in series), 150°C, in stator winding.	M	M	M
435	PTC-thermistors (3 in series), 130°C in stator winding.	M	M	M
436	PTC-thermistors (3 in series), 150°C in stator winding.	M	M	M
437	PTC-thermistors (3 in series), 170°C in stator winding.	M	M	M
<b>Terminal box</b>				
021	Terminal box LHS (seen from D-end).	NA	M	M
136	Extended cable connection, standard terminal box.	P	P	M
137	Extended cable connection, low terminal box.	P	P	P
180	Terminal box RHS (seen from D-end).	NA	M	M
230	Standard cable gland.	M	M	M
731	Two standard cable glands.	NA	M	M
<b>Testing</b>				
146	Type test with report for motor from specific delivery batch.	P	P	P
147	Type test with report for motor from specific delivery batch, customer witnessed.	P	P	P
148	Routine test report.	P	P	R
149	Test according to separate test specification.	NA	NA	R
221	Type test and multi-point load test with report for motor from specific delivery batch.	R	R	P
222	Torque/speed curve, type test and multi-point load test with report from specific delivery batch.	R	R	P
760	Vibration level test.	P	P	R
762	Noise level test.	P	P	P

1) Certain variant codes cannot be used simultaneously.

S = Included as standard.  
M = On modification of a stocked motor,  
or on new manufacture,  
the number per order may be limited.

P = New manufacture only.  
R = On request.  
NA = Not available.

# General purpose single phase motors

## Dimension drawings

### Foot-mounted motor IM B3 (IM 1001)

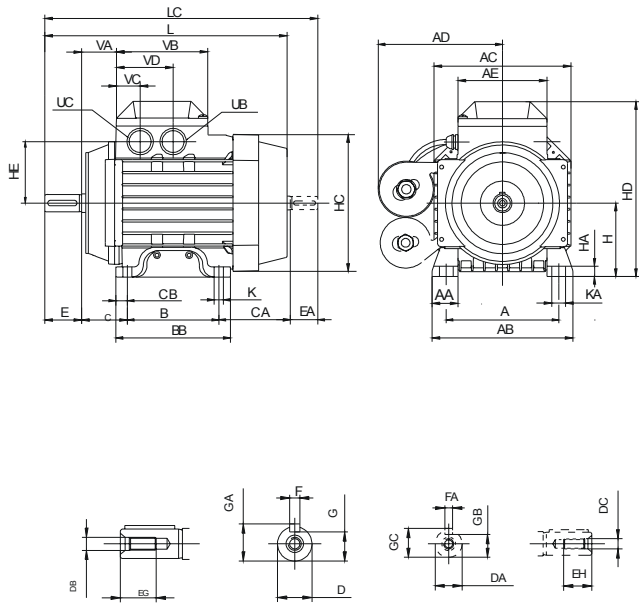

### Flange-mounted motor IM B5 (IM 3001), large flange

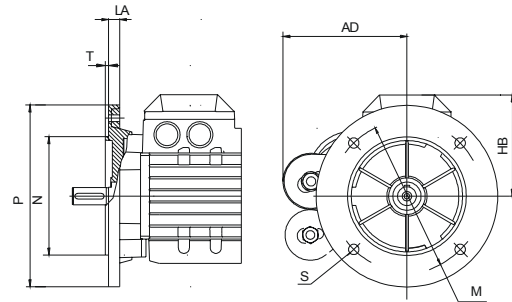

### IM B14 (IM 3601), small flange

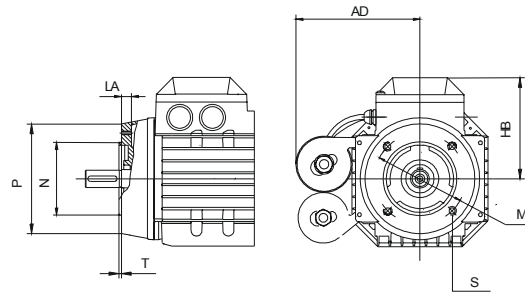

### IM B3 (IM 1001)

Motor size	A	AA	AB	AC	AD	AE	B	BB	C	CA	CB	D	DA	DB	DC	E	EA	EG	EH	F	FA
56	90	18	108	110	110	72	71	85	36	78	7	9	9	M3	M3	20	20	9	9	3	3
63	100	26	120	120	110	72	80	96	40	71	8	11	11	M4	M4	23	23	10	10	4	4
71	112	24	136	130	125	85	90	110	45	78	10	14	11	M5	M4	30	23	13	10	5	4
80	125	28	154	150	130	97	100	125	50	80	12.5	19	14	M6	M5	40	30	16	13	6	5
90 S	140	27	170	177	140	110	100	125	56	81	12.5	24	14	M8	M5	50	30	19	12.5	8	5
90 L	140	27	170	177	135	110	125	150	56	81	12.5	24	14	M8	M5	50	30	19	12.5	8	5
100 L	160	32	197	197	155	110	140	172	63	91	16	28	19	M10	M6	60	40	22	19	8	6

Motor size	G	GA	GB	GC	H	HA	HC	HD	HE	K	KA	L	LC	UB	UC	VA	VB	VC	VD
56	7.2	10.2	7.2	10.2	56	8	110	159	71	5.8	9	197	225	Pg11	M16x1.5	30	72	26	53
63	8.5	12.5	8.5	12.5	63	10	120	171	76	7	11	205	237	Pg11	M16x1.5	36	72	26	53
71	11	16	8.5	12.5	71	9	130	176	63	7	10	238	266	Pg16	M20x1.5	35	92	22	57
80	15.5	21.5	11	16	80	10	150	190	67	10	15	265	300	Pg16	M20x1.5	37	100	26	61
90 S	20	27	11	16	90	10	177	217	82.5	10	14	282	317	M25	M25x1.5	43.5	110	33	67
90 L	20	27	11	16	90	10	177	217	82.5	10	14	307	342	M25	M25x1.5	43.5	110	33	67
100 L	24	31	15.5	21.5	100	12	197	237	92.5	12	15	349	394	M25	M25x1.5	47	110	33	67

### IM B5 (IM 3001)

Motor size	HB	LA	M	N	P	S	T
56	103	10	100	80	120	7	3
63	108	10	115	95	140	10	3
71	105	10	130	110	160	10	3.5
80	110	12	165	130	200	12	3.5
90 S	127	10	165	130	200	12	3.5
90 L	127	10	165	130	200	12	3.5
100 L	137	11	215	180	200	15	4

### IM B14 (IM 3601)

Motor size	HB	LA	M	N	P	S	T
56	103	10	65	50	80	M5	2.5
63	108	10	75	60	90	M5	2.5
71	105	10	85	70	105	M6	2.5
80	110	10	100	80	120	M6	3
90 S	127	13	115	95	140	M8	3
90 L	127	13	115	95	140	M8	3
100 L	137	14	130	110	160	M8	3.5

#### Tolerances

A, B	ISO js 14	F	ISO h9
C	± 0.8	H	+0 -0.5
D, DA	ISO j6	N	ISO j6

Above table gives the main dimensions in mm.  
For detailed drawings please see our web-site  
'[www.abb.com/motors&drives](http://www.abb.com/motors&drives)' or contact us.

# General purpose single phase motors

## Dimension drawings

Foot- and flange-mounted motor, large flange IM B35 (IM 2001)

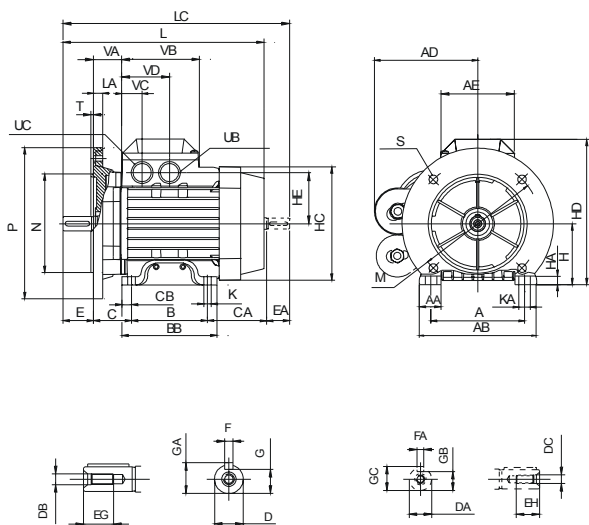

Foot- and flange-mounted motor, small flange IM B34 (IM 2101)

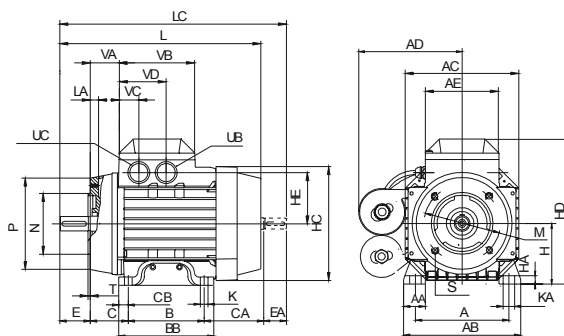

IM B35 (IM 2001); IM B34 (IM 2101)

Motor size	A	AA	AB	AC	AD	AE	B	BB	C	CA	CB	D	DA	DB	DC	E	EA	EG	EH	F	FA
56	90	18	108	110	110	72	71	85	36	78	7	9	9	M3	M3	20	20	9	9	3	3
63	100	26	120	120	110	72	80	96	40	71	8	11	11	M4	M4	23	23	10	10	4	4
71	112	24	136	130	125	85	90	110	45	78	10	14	11	M5	M4	30	23	13	10	5	4
80	125	28	154	150	130	97	100	125	50	80	12.5	19	14	M6	M5	40	30	16	13	6	5
90 S	140	27	170	177	140	110	100	125	56	81	12.5	24	14	M8	M5	50	30	19	12.5	8	5
90 L	140	27	170	177	135	110	125	150	56	81	12.5	24	14	M8	M5	50	30	19	12.5	8	5
100 L	160	32	197	197	155	110	140	172	63	91	16	28	19	M10	M6	60	40	22	19	8	6

Motor size	G	GA	GB	GC	H	HA	HC	HD	HE	K	KA	L	LC	UB	UC	VA	VB	VC	VD
56	7.2	10.2	7.2	10.2	56	8	110	159	71	5.8	9	197	225	Pg11	M16x1.5	30	72	26	53
63	8.5	12.5	8.5	12.5	63	10	120	171	76	7	11	205	237	Pg11	M16x1.5	36	72	26	53
71	11	16	8.5	12.5	71	9	130	176	63	7	10	238	266	Pg16	M20x1.5	35	92	22	57
80	15.5	21.5	11	16	80	10	150	190	67	10	15	265	300	Pg16	M20x1.5	37	100	26	61
90 S	20	27	11	16	90	10	177	217	82.5	10	14	282	317	M25	M25x1.5	43.5	110	33	67
90 L	20	27	11	16	90	10	177	217	82.5	10	14	307	342	M25	M25x1.5	43.5	110	33	67
100 L	24	31	15.5	21.5	100	12	197	237	82.5	12	15	349	394	M25	M25x1.5	47	110	33	67

IM 2001, IM B35

Motor size	HB	LA	M	N	P	S	T
56	103	10	100	80	120	7	3
63	108	10	115	95	140	10	3
71	105	10	130	110	160	10	3.5
80	110	12	165	130	200	12	3.5
90 S	127	10	165	130	200	12	3.5
90 L	127	10	165	130	200	12	3.5
100 L	137	11	215	180	250	15	4

IM 2101, IM B34

Motor size	HB	LA	M	N	P	S	T
56	103	10	65	50	80	M5	2.5
63	108	10	75	60	90	M5	2.5
71	105	10	85	70	105	M6	2.5
80	110	10	100	80	120	M6	3
90 S	127	13	115	95	140	M8	3
90 L	127	13	115	95	140	M8	3
100 L	137	14	130	110	160	M8	3.5

**Tolerances**

A, B	ISO js 14	F	ISO h9
C	± 0.8	H	+0 -0.5
D, DA	ISO j6	N	ISO j6

Above table gives the main dimensions in mm. For detailed drawings please see our web-site 'www.abb.com/motors&drives' or contact us.

# General purpose single phase motors in brief, basic design

Motor size		56	63	71	80	90	100
Stator and feet	Material	Die-cast aluminium alloy. Feet integrated with stator in sizes 63; loose feet in sizes 56 and 71-100.					
	Surface treatment	One-component modified polyester powder paint. Munsell blue 8B 4.5/3.25 / NCS 4822 BO5G, $\geq 30 \mu\text{m}$ .					
Bearing end shields	Material	Die-cast aluminium alloy.					
	Surface treatment	One-component modified polyester powder paint. Munsell blue 8B 4.5/3.25 / NCS 4822 BO5G, $\geq 30 \mu\text{m}$ .					
Bearings	D-end	6201-2Z/C3	6202-2Z/C3	6203-2Z/C3	6304-2Z/C3	6205-2Z/C3	6306-2Z/C3
	N-end	6201-2Z/C3	6201-2Z/C3	6202-2Z/C3	6203-2Z/C3	6204-2Z/C3	6205-2Z/C3
Axially locked bearings	Internal bearing cap	<sup>1)</sup>	<sup>1)</sup>	<sup>1)</sup>	<sup>1)</sup>	D-end	D-end
		<sup>1)</sup> By foot-mounted motors and motors with small flange: A spring washer in N-end presses the rotor against D-end.					
Bearing seals	D-end	V ring.					
	N-end	Labyrinth seal.					
Lubrication		Permanently lubricated bearings. Grease temperature (-30...+150°C).					
Terminal box	Material	Die-cast aluminium alloy.					
	Surface treatment	Similar to stator.					
	Screws	Steel 5 G, galvanised and yellow chromated.					
Connections	Connection openings	4 x M16		4 x M20		4 x M25	
	Terminal box Max Cu range, mm <sup>2</sup>	Screw terminal, 6 terminals. PSC = 2.5. CSR = 1.5.					
Fan	Material	Polypropylene. Reinforced with 20% glass fibre.					
Fan hood	Material	Metal.					
Stator winding	Material	Copper.					
	Impregnation	Polyester coating. Tropicalized.					
	Insulation class	Insulation class F.					
Rotor winding	Material	Die-cast aluminium.					
Balancing method		Half key balancing.					
Key way		Closed key way.					
Heating elements	On request	8 W	8 W	8 W	25 W	25 W	25 W
Enclosure		IP 55.					
Cooling method		IC 411.					
Drain holes		Standard.					







# Drive<sup>IT</sup> Integral Motors

Totally enclosed squirrel cage three phase low voltage motors,  
Sizes 71 - 100, 0.37 to 2.2 kW



<b>Features.....</b>	<b>210</b>
<b>Connections.....</b>	<b>211</b>
<b>Ordering information.....</b>	<b>212</b>
<b>Technical data.....</b>	<b>213</b>
<b>Technical specification for frequency converter.....</b>	<b>217</b>
<b>Variant codes.....</b>	<b>219</b>
<b>Derating information.....</b>	<b>221</b>
<b>Dimensions.....</b>	<b>222</b>

# Features

## Drive<sup>IT</sup> Integral Motor - the choice for a demanding environment

Demanding environments place a requirement for high protection class motors with good vibration endurance. This is why the integral motor is IP 55 protected. In addition to the wide selection of digital and analogue user interfaces, the integral motor offers higher integration into the modern control system with its fieldbuses, to meet the demands for distributed control.

## Products according to your needs

Integral motor models are available as 2, 4 or 6 pole versions. The integral motor is delivered as an integrated, ready-to-use unit equipped with a brake, separate ventilation, or any other selected variants. The pre-set parameters offer configuration required by most of the simple applications and make commissioning and use as easy as possible. For more demanding applications, an optional control panel or PC software tool can be used to select from a range of more advanced application macros.

## Fulfil EMC limits at every level

Electro Magnetic Compatibility is an important issue in AC automation. The integral motor complies with European distribution limits with the help of built-in EMC filters, so that no external filtering is needed. Standard models of the integral motor fulfil EMC requirements in industrial environments and models with RFI filter in the domestic environments.

## Excellent features for OEM's

The integral motor provides a low cost way to enhance an application's performance: it is not limited to "soft starting" applications in which integrated motor-drive combinations have traditionally been used.

Features include up to 180 % overload capacity during start-up, PTC interface, built-in mechanical brake control and electrical braking produce an unbeatable combination for material handling applications. The robust design withstands supply voltage fluctuations and the wide selection of fieldbus options makes integration into automation systems easy.

One of the most interesting features is the Positioning Macro, which together with an optional encoder makes it possible to eliminate expensive PLCs in simple positioning applications. This feature is useful for example in controlling conveyor lines or opening doors.

## Intelligent control for pumps and fans

The built-in PID controller's two parameter sets make the integral motor ideally suited for pump and fan applications. The integral motor can be configured to indicate directly parameters such as the flow rate of a pumped fluid, for instance. With the integral motor it is possible to make a connection to building automation via a LonWorks fieldbus adapter.

Typically no overload capacity is needed in pump or fan applications. This allows the integral motor to be optimised for squared torque use.

### The integral motor offers

- Mounting to demanding environment
- Ready-to-use configuration with pre-set parameters
- Full configurable functionality when using an IP65 control panel
- Easy adaptation to automation systems with wide range of fieldbuses
- Built-in EMC filter and brake chopper
- Simple positioning tasks with Positioning application macro
- Optimised selection integral motor models and integrated variants



# Connections

To achieve maximum compatibility the integral motor provides all necessary connections and options. Options are IP 65 protected which means that they can withstand extremely hostile environments like places with high moisture. Options are placed straight on the side of the drive and no extra installing space is required.

The various options are shown below. After the integral motor has been specified, it will be delivered as a ready assembled and parametrized unit.

With analogue inputs you can set the output frequency or control positioning speed or direction. As there are two analogue inputs, intelligent PID control is possible.

Analogue output can indicate chosen operating data values like output current or DC bus voltage.

With digital inputs the integral motor can be e.g. started, stopped or the rotation direction changed. Digital inputs are also used in positioning function.

Two relay outputs pass fault and alarm signals or indicate when selected parameter values are exceeded.

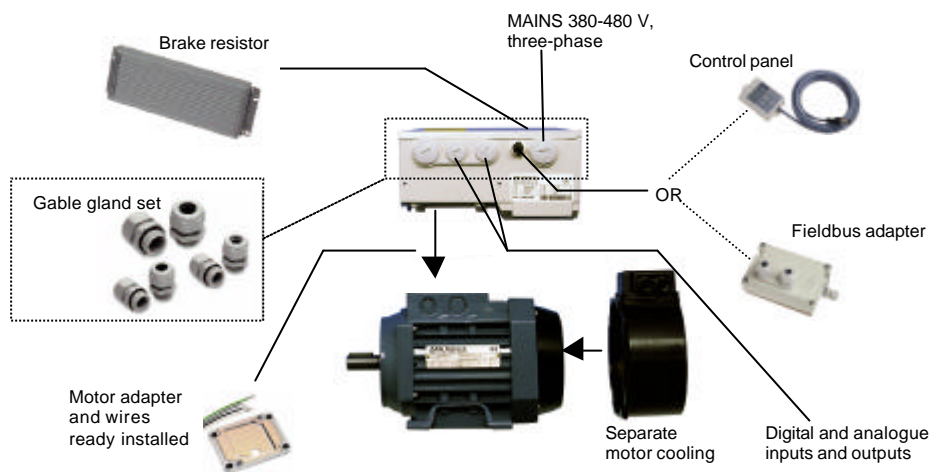

## I/O Connection Examples

These connections are shown as examples only. More detailed information can be found from the frequency converter part's User's Manual.

Drive NPN connected

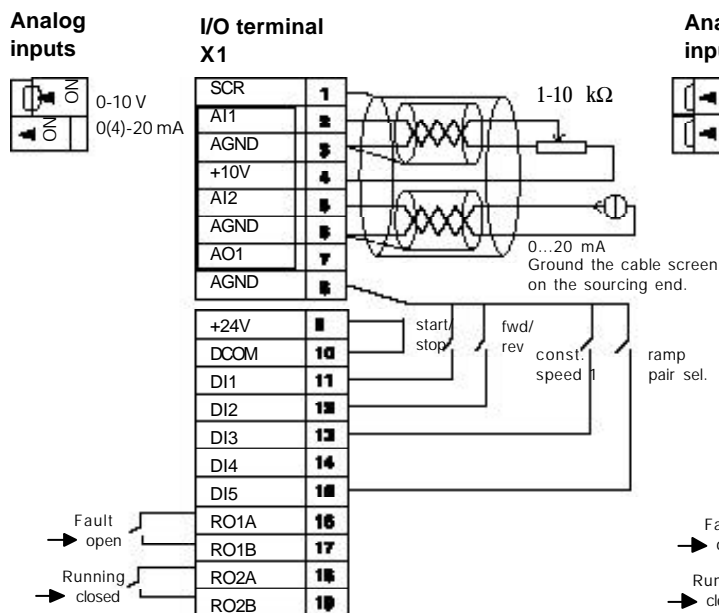

Drive PNP connected with external power supply

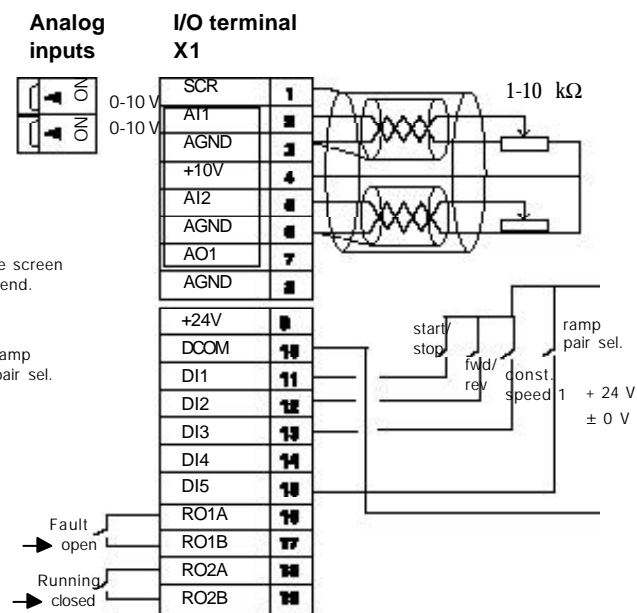

# Ordering information

## Sample order

### 1. Standard design

When ordering an integral motor, please state the following minimum data in the order, as in the example.

### 2. Special designs

In addition to the minimum data all special features desired shall be stated expressly in the text of the order.

### 3. Note

- If the order is based on a quotation please state the number
- If the same motors were supplied before (replacement motors) please state their serial number (see motor rating plate).

Motor type	M3VK 80C
Pole number	4
Mounting arrangement (IM-code)	IM B3 (IM 1001)
Rated output	0.75 kW
Product code	3GVK082662-ASC
Variant codes if needed	
Type of drive	Standard drive

A	B	C	D	E	F	G
M3VK	80C	3GVK 082 662 - A S C, 450 etc.				
		1-4	5-6	7	8-10	11 12 13 14

**A** Motor type  
**B** Motor size  
**C** Product code  
**D** Mounting arrangement code  
**E** Voltage and frequency code  
**F** Generation code  
**G** Variant codes

### Explanation of the product code:

#### Positions 1 to 4

3GVK = Business area LV Motors  
 Totally enclosed fan cooled squirrel cage  
 integral motor with aluminium frame

#### Positions 5 and 6

##### IEC-frame

07 = 71  
 08 = 80  
 09 = 90  
 10 = 100

#### Position 7

##### Speed (Pole pairs)

1 = 2 poles  
 2 = 4 poles  
 3 = 6 poles

#### Position 8

6 = Standard Drive  
 7 = Drive with RFI filter

#### Position 9-10 - Running number series

#### Position 11

- (Dash)

#### Position 12

##### Mounting arrangement

**A** = Foot-mounted motor.  
**B** = Flange-mounted motor. Large flange with clearance holes.  
**C** = Foot-mounted motor. Small flange with tapped holes.  
**F** = Foot- and flange-mounted motor. Special flange.  
**H** = Foot- and flange-mounted motor. Large flange with clearance holes.  
**J** = Foot- and flange-mounted motor. Small flange with tapped holes.  
**V** = Flange-mounted motor. Special flange.

#### Position 13

##### Voltage and frequency code

##### Single-speed

**D** = 380-420 VD 50 Hz  
 440-480 VD 60 Hz  
**S** = 220-240 VD 50 Hz  
 380-420 VY 50 Hz  
 440-480 VY 60 Hz  
**X** = Other voltage/frequency

#### Position 14

Generation code = A, B, C...

**The product code must be, if needed, followed by variant codes.**

# General purpose integral motors

## For constant torque applications



### TEFC squirrel cage three-phase integral motors M3VK

#### IP55, IC 411; Insulation class F, temperature rise class B

Output kW	Type designation	Product code	Input current $I_{IN}$ A	Cont. output current $I_{2N}^{(1,2)}$ A	Max. current 150 % $I_{max}^{(3)}$ A	Max. starting current 180 % <sup>(4)</sup> A	Over current limit (peak) A	Line fuse <sup>(5)</sup> A	Power losses Power circuit W	Control circuit W	Total weight kg
<b>3000 r/min = 2 poles</b>			<b>380-480 V 50 Hz</b>			<b>Standard Drive</b>					
0.37	M3VK 71A	3GVK 071 661-••C	1.6	1.8	2.7	3.2	7.1	4	17	16	10
0.55	M3VK 71B	3GVK 071 662-••C	1.6	1.8	2.7	3.2	7.1	4	17	16	11
0.75	M3VK 80A	3GVK 081 661-••C	2.2	2.4	3.6	4.3	9.5	4	23	17	14
1.1	M3VK 80B	3GVK 081 662-••C	3.2	3.4	5.1	6.1	13	6	33	18	16
1.5	M3VK 80C	3GVK 081 663-••C	4.1	4.1	6.2	7.4	16	10	45	19	16
1.5	M3VK 90S	3GVK 091 661-••C	4.1	4.1	6.2	7.4	16	10	45	19	18
2.2	M3VK 90L	3GVK 091 662-••C	6.0	5.4	8.1	9.7	21	10	66	20	21
<b>1500 r/min = 4 poles</b>			<b>380-480 V 50 Hz</b>			<b>Standard Drive</b>					
0.37	M3VK 71B	3GVK 072 662-••C	1.6	1.8	2.7	3.2	7.1	4	17	16	11
0.55	M3VK 80A	3GVK 082 662-••C	1.6	1.8	2.7	3.2	7.1	4	17	16	14
0.75	M3VK 80B	3GVK 082 662-••C	2.2	2.4	3.6	4.3	9.5	4	23	17	15
0.95	M3VK 80C	3GVK 082 663-••C	3.2	3.4	5.1	6.1	13	6	33	18	16
1.1	M3VK 90S	3GVK 092 661-••C	3.2	3.4	5.1	6.1	13	6	33	18	18
1.5	M3VK 90L	3GVK 092 662-••C	4.1	4.1	6.2	7.4	16	10	45	19	21
2.2	M3VK 100LA	3GVK 102 661-••C	6.0	5.4	8.1	9.7	21	10	66	20	26
<b>1000 r/min = 6 poles</b>			<b>380-480 V 50 Hz</b>			<b>Standard Drive</b>					
0.37	M3VK 71A	3GVK 083 661-••C	1.6	1.8	2.7	3.2	7.1	4	17	16	14
0.55	M3VK 80B	3GVK 083 662-••C	1.6	1.8	2.7	3.2	7.1	4	17	16	15
0.75	M3VK 90S	3GVK 093 661-••C	2.2	2.4	3.6	4.3	9.5	4	23	17	18
1.1	M3VK 90L	3GVK 093 662-••C	3.2	3.4	5.1	6.1	13	6	33	18	21
1.5	M3VK 100L	3GVK 103 661-••C	4.1	4.1	6.2	7.4	16	10	45	19	28
<b>3000 r/min = 2 poles</b>			<b>380-480 V 50 Hz</b>			<b>Drive with RFI filter</b>					
0.37	M3VK 71A	3GVK 071 761-••C	1.6	1.8	2.7	3.2	7.1	4	17	18	12
0.55	M3VK 71B	3GVK 071 762-••C	1.6	1.8	2.7	3.2	7.1	4	17	18	13
0.75	M3VK 80A	3GVK 081 761-••C	2.2	2.4	3.6	4.3	9.5	4	23	19	15
1.1	M3VK 80B	3GVK 081 762-••C	3.2	3.4	5.1	6.1	13	6	33	20	17
1.5	M3VK 80C	3GVK 081 763-••C	4.1	4.1	6.2	7.4	16	10	45	21	18
1.5	M3VK 90S	3GVK 091 761-••C	4.1	4.1	6.2	7.4	16	10	45	21	19
2.2	M3VK 90L	3GVK 091 762-••C	6.0	5.4	8.1	9.7	21	10	66	22	23
<b>1500 r/min = 4 poles</b>			<b>380-480 V 50 Hz</b>			<b>Drive with RFI filter</b>					
0.37	M3VK 71A	3GVK 072 762-••C	1.6	1.8	2.7	3.2	7.1	4	17	18	13
0.55	M3VK 80A	3GVK 082 761-••C	1.6	1.8	2.7	3.2	7.1	4	17	18	15
0.75	M3VK 80B	3GVK 082 762-••C	2.2	2.4	3.6	4.3	9.5	4	23	19	16
0.95	M3VK 80C	3GVK 082 763-••C	3.2	3.4	5.1	6.1	13	6	33	20	17
1.1	M3VK 90S	3GVK 092 761-••C	3.2	3.4	5.1	6.1	13	6	33	20	19
1.5	M3VK 90L	3GVK 092 762-••C	4.1	4.1	6.2	7.4	16	10	45	21	22
2.2	M3VK 100LA	3GVK 102 761-••C	6.0	5.4	8.1	9.7	21	10	66	22	28
<b>1000 r/min = 6 poles</b>			<b>380-480 V 50 Hz</b>			<b>Drive with RFI filter</b>					
0.37	M3VK 71A	3GVK 083 761-••C	1.6	1.8	2.7	3.2	7.1	4	17	18	15
0.55	M3VK 80B	3GVK 083 762-••C	1.6	1.8	2.7	3.2	7.1	4	17	18	16
0.75	M3VK 90S	3GVK 093 761-••C	2.2	2.4	3.6	4.3	9.5	4	23	19	19
1.1	M3VK 90L	3GVK 093 762-••C	3.2	3.4	5.1	6.1	13	6	33	20	22
1.5	M3VK 100L	3GVK 103 761-••C	4.1	4.1	6.2	7.4	16	10	45	21	29

The two bullets in the product code indicate choice of mounting arrangement, voltage and nominal frequency.

1) Power stages are designed for the continuous  $I_{2N}$  current.

These values apply at altitudes less than 1000 m ASL.

2) With 8 kHz switching frequency derate  $I_{2N}$  to 70% in -10°C...40°C or to 60% in 40°C...50°C.

3) 150 % of nominal current  $I_{2N}$  allowed for one minute every 10 minutes.

4) 180 % of nominal current  $I_{2N}$  allowed for two seconds.

5) Fuse type: UL class CC or T. For non-UL installations IEC269gG.

Use 60°C rated power cable (75°C if  $T_{amb}$  above 45°C).

Follow local rules for cable cross-sections.

Shielded motor cable is recommended.

Max. wire sizes/Power terminals (mm<sup>2</sup>):

single core: 4 (AWG 12), stranded: 2.5 (AWG 14)/torque 0.8 Nm

Max. wire sizes/Control terminals (mm<sup>2</sup>):

0.5-1.5 (AWG 22...AWG 16)/torque 0.4 Nm.

# General purpose integral motors

## For constant torque applications



TEFC squirrel cage three-phase integral motors M3VK  
IP55, IC 411; Insulation class F, temperature rise class B

Output Type kW	Product designation	Product code	Input current $I_{1N}$ A	Cont. output current $I_{2N}^{1)}$ A	Max. current 150 % $I_{max}^{2)}$ A	Max. starting current 180 % <sup>3)</sup> A	Over current limit (peak) A	Line fuse <sup>4)</sup> A	Power losses		Total weight kg
									Power circuit W	Control circuit W	
<b>3000 r/min = 2 poles</b>			<b>380-480 V 50 Hz</b>			<b>Standard Drive</b>					
1.1	M3VK 80C	3GVK 081 673-••C	3.2	3.4	5.1	6.1	13	6	33	18	16
1.5	M3VK 90L	3GVK 091 672-••C	4.1	4.1	6.2	7.4	16	10	45	19	21
2.2	M3VK 90LB	3GVK 091 673-••C	6.0	5.4	8.1	9.7	21	10	66	20	23
<b>1500 r/min = 4 poles</b>			<b>380-480 V 50 Hz</b>			<b>Standard Drive</b>					
1.1	M3VK 90L	3GVK 092 672-••C	3.2	3.4	5.1	6.1	13	6	33	18	21
1.5	M3VK 100LA	3GVK 102 671-••C	4.1	4.1	6.2	7.4	16	10	45	19	26
2.2	M3VK 100LC	3GVK 102 673-••C	6.0	5.4	8.1	9.7	21	10	66	20	30
<b>3000 r/min = 2 poles</b>			<b>380-480 V 50 Hz</b>			<b>Drive with RFI filter</b>					
1.1	M3VK 80C	3GVK 081 773-••C	3.2	3.4	5.1	6.1	13	6	33	20	17
1.5	M3VK 90L	3GVK 091 772-••C	4.1	4.1	6.2	7.4	16	10	45	21	22
2.2	M3VK 90LB	3GVK 091 773-••C	6.0	5.4	8.1	9.7	21	10	66	22	25
<b>1500 r/min = 4 poles</b>			<b>380-480 V 50 Hz</b>			<b>Drive with RFI filter</b>					
1.1	M3VK 90L	3GVK 092 772-••C	3.2	3.4	5.1	6.1	13	6	33	20	22
1.5	M3VK 100LA	3GVK 102 771-••C	4.1	4.1	6.2	7.4	16	10	45	21	27
2.2	M3VK 100LC	3GVK 102 773-••C	6.0	5.4	8.1	9.7	21	10	66	22	32

The two bullets in the product code indicate choice of mounting arrangement, voltage and nominal frequency.

- 1) Power stages are designed for the continuous  $I_{2N}$  current. These values apply at altitudes less than 1000 m ASL.
- 2) With 8 kHz switching frequency derate  $I_{2N}$  to 70% in -10°C...40°C or to 60% in 40°C...50°C.
- 3) 150 % of nominal current  $I_{2N}$  allowed for one minute every 10 minutes.
- 4) 180 % of nominal current  $I_{2N}$  allowed for two seconds.
- 5) Fuse type: UL class CC or T. For non-UL installations IEC269gG.

Use 60°C rated power cable (75°C if  $T_{amb}$  above 45°C).  
Follow local rules for cable cross-sections.  
Shielded motor cable is recommended.  
Max. wire sizes/Power terminals (mm<sup>2</sup>):  
single core: 4 (AWG 12), stranded: 2.5 (AWG 14)/torque 0.8 Nm  
Max. wire sizes/Control terminals (mm<sup>2</sup>):  
0.5-1.5 (AWG 22...AWG 16)/torque 0.4 Nm.

# General purpose integral motors

For pump and fan use, squared torque applications



TEFC squirrel cage three-phase integral motors M3VK  
IP55, IC 411; Insulation class F, temperature rise class B

Output kW	Type designation	Product code	Input current $I_{IN}$	Cont. output current $I_{2NSQ}^{1),2),3)}$	Over current limit (peak)	Line fuse <sup>4)</sup>	Power losses		Total weight	
							Power circuit	Control circuit		
			A	A	A	A	W	W	kg	
<b>3000 r/min = 2 poles</b>			<b>380-480 V 50 Hz</b>			<b>Standard Drive</b>				
0.75	M3VK 80A	3GVK 081 861-••C	1.6	2.2	7.1	4	17	16	14	
1.1	M3VK 80B	3GVK 081 862-••C	2.2	2.8	9.5	4	23	17	16	
1.5	M3VK 80C	3GVK 081 863-••C	3.2	3.8	13	6	33	18	16	
1.5	M3VK 90S	3GVK 091 861-••C	3.2	3.8	13	6	33	18	18	
2.2	M3VK 90L	3GVK 091 862-••C	4.1	5.0	16	10	45	19	21	
3.0	M3VK 100L	3GVK 101 861-••C	6.0	6.6	21	10	66	20	27	
<b>1500 r/min = 4 poles</b>			<b>380-480 V 50 Hz</b>			<b>Standard Drive</b>				
0.75	M3VK 80B	3GVK 082 862-••C	1.6	2.2	7.1	4	17	16	15	
1.1	M3VK 90S	3GVK 092 861-••C	2.2	2.8	9.5	4	23	17	18	
1.5	M3VK 90L	3GVK 092 862-••C	3.2	3.8	13	6	33	18	21	
2.2	M3VK 100LA	3GVK 102 861-••C	4.1	5.0	16	10	45	19	26	
3.0	M3VK 100LB	3GVK 102 862-••C	6.0	6.6	21	10	66	20	30	
<b>3000 r/min = 2 poles</b>			<b>380-480 V 50 Hz</b>			<b>Drive with RFI filter</b>				
0.75	M3VK 80A	3GVK 081 961-••C	1.6	2.2	7.1	4	17	18	15	
1.1	M3VK 80B	3GVK 081 962-••C	2.2	2.8	9.5	4	23	19	17	
1.5	M3VK 80C	3GVK 081 963-••C	3.2	3.8	13	6	33	20	18	
1.5	M3VK 90S	3GVK 091 961-••C	3.2	3.8	13	6	33	20	19	
2.2	M3VK 90L	3GVK 091 962-••C	4.1	5.0	16	10	45	21	22	
3.0	M3VK 100L	3GVK 102 961-••C	6.0	6.6	21	10	66	22	28	
<b>1500 r/min = 4 poles</b>			<b>380-480 V 50 Hz</b>			<b>Drive with RFI filter</b>				
0.75	M3VK 80B	3GVK 082 962-••C	1.6	2.2	7.1	4	17	18	16	
1.1	M3VK 90S	3GVK 092 961-••C	2.2	2.8	9.5	4	23	19	19	
1.5	M3VK 90L	3GVK 092 962-••C	3.2	3.8	13	6	33	20	22	
2.2	M3VK 100LA	3GVK 102 961-••C	4.1	5.0	16	10	45	21	27	
3.0	M3VK 100LB	3GVK 102 962-••C	6.0	6.6	21	10	66	22	31	

The two bullets in the product code indicate choice of mounting arrangement, voltage and nominal frequency.

- 1) Power stages are designed for the continuous  $I_{2NSQ}$  current. These values apply at altitudes less than 1000 m ASL.
- 2) With 8 kHz switching frequency derate  $I_{2NSQ}$  to 70% in -10°C...40°C or to 60% in 40°C...50°C.
- 3) No overloadability
- 4) Fuse type: UL class CC or T. For non-UL installations IEC269gG.

Use 60°C rated power cable (75°C if  $T_{amb}$  above 45°C).  
Follow local rules for cable cross-sections.  
Shielded motor cable is recommended.  
Max. wire sizes/Power terminals (mm<sup>2</sup>):  
single core: 4 (AWG 12), stranded: 2.5 (AWG 14)/torque 0.8 Nm.  
Max. wire sizes/Control terminals (mm<sup>2</sup>):  
0.5-1.5 (AWG 22...AWG 16)/torque 0.4 Nm.

For 6 poles integral motors in Pump&Fan application select a product from General purpose codes.

# General purpose integral motors

For pump and fan use, squared torque applications



TEFC squirrel cage three-phase integral motors M3VK  
IP55, IC 411; Insulation class F, temperature rise class B

Output kW	Type designation	Product code	Input current $I_{IN}$	Cont. output current $I_{2NSQ}^{1),2),3)}$	Over current limit (peak)	Line fuse <sup>4)</sup>	Power losses		Total weight
							Power circuit	Control circuit	
			A	A	A	A	W	W	kg
<b>3000 r/min = 2 poles</b>			<b>380-480 V 50 Hz</b>			<b>Standard Drive</b>			
1.1	M3VK 80C	3GVK 081 873-••C	2.2	2.8	9.5	4	23	17	16
1.5	M3VK 90L	3GVK 091 872-••C	3.2	3.8	13	6	33	18	21
2.2	M3VK 90LB	3GVK 091 873-••C	4.1	5.0	16	10	45	19	23
3.0	M3VK 100LB	3GVK 101 873-••C	6.0	6.6	21	10	66	20	31
<b>1500 r/min = 4 poles</b>			<b>380-480 V 50 Hz</b>			<b>Standard Drive</b>			
1.1	M3VK 90L	3GVK 092 872-••C	2.2	2.8	9.5	4	23	17	21
1.5	M3VK 100LA	3GVK 102 871-••C	3.2	3.8	13	6	33	18	26
2.2	M3VK 100LC	3GVK 102 873-••C	4.1	5.0	16	10	45	19	30
<b>3000 r/min = 2 poles</b>			<b>380-480 V 50 Hz</b>			<b>Drive with RFI filter</b>			
1.1	M3VK 80C	3GVK 081 973-••C	2.2	2.8	9.5	4	23	19	17
1.5	M3VK 90L	3GVK 091 972-••C	3.2	3.8	13	6	33	20	22
2.2	M3VK 90LB	3GVK 091 973-••C	4.1	5.0	16	10	45	21	24
3.0	M3VK 100LB	3GVK 101 973-••C	6.0	6.6	21	10	66	22	31
<b>1500 r/min = 4 poles</b>			<b>380-480 V 50 Hz</b>			<b>Drive with RFI filter</b>			
1.1	M3VK 90L	3GVK 092 972-••C	2.2	2.8	9.5	4	23	19	22
1.5	M3VK 100LA	3GVK 102 971-••C	3.2	3.8	13	6	33	20	27
2.2	M3VK 100LC	3GVK 102 973-••C	4.1	5.0	16	10	45	21	31

The two bullets in the product code indicate choice of mounting arrangement, voltage and nominal frequency.

- 1) Power stages are designed for the continuous  $I_{2NSQ}$  current. These values apply at altitudes less than 1000 m ASL.
- 2) With 8 kHz switching frequency derate  $I_{2NSQ}$  to 70% in -10°C...40°C or to 60% in 40°C...50°C.
- 3) No overloadability
- 4) Fuse type: UL class CC or T. For non-UL installations IEC269gG.

Use 60°C rated power cable (75°C if  $T_{amb}$  above 45°C).  
Follow local rules for cable cross-sections.  
Shielded motor cable is recommended.  
Max. wire sizes/Power terminals (mm<sup>2</sup>):  
single core: 4 (AWG 12), stranded: 2.5 (AWG 14)/torque 0.8 Nm.  
Max. wire sizes/Control terminals (mm<sup>2</sup>):  
0.5-1.5 (AWG 22...AWG 16)/torque 0.4 Nm.

For 6 poles integral motors in Pump&Fan application select a product from General purpose codes.



# Technical Specification for Frequency Converter

## Mains connection

- Power range:** 0.55 - 3.0 kW  
**Voltage:** 3-phase, 380 to 480 V  $\pm$  10 %  
**Frequency:** 48 to 63 Hz  
**Power factor:** 0.98

## Motor connection

- Voltage:** 3-phase, from 0 to  $U_{\text{supply}}$   
**Frequency:** 0 to 250 Hz

## Constant torque applications

### Continuous loading capability:

- Rated output current  $I_{2N}$

### Overload capacity (max. ambient temperature of 40°C):

- At constant torque:  $1.5 \cdot I_{2N}$  for one minute every 10 minutes
  - Starting torque:  $1.8 \cdot I_{2N}$  for two seconds
- Characteristic data for short time, intermittent and periodic load cycles are available on request.

### Switching frequency:

- Standard 4 kHz
- Low noise 8 kHz \*)

## Squared torque applications

### Continuous loading capability:

- Rated output current  $I_{2NSQ}$

### No overload capacity

### Switching frequency:

- Standard 4 kHz
- Low noise 8 kHz \*) , with derating

## Programmable control connections

### Two analogue inputs:

- Voltage signal: 0 (2) to 10 V, 200 k $\Omega$  single ended
- Current signal: 0 (4) to 20 mA, 500  $\Omega$  single ended
- Potentiometer reference: 10 V  $\pm$  2 % max. 10 mA, 1 k $\Omega$   $\leq$  R  $\geq$  10k $\Omega$
- Response time: < 64 ms
- Resolution: 0.1 %
- Accuracy:  $\pm$  1 %

### One analogue output: 0 (4) to 20 mA, load < 500 $\Omega$

### Auxiliary voltage: 24 V DC, max 180 mA

### Five digital inputs: 12-24 V DC with internal or external supply, PNP and NPN logic

- Input impedance: 1.5 k $\Omega$
- Response time: < 5 ms

### Two relay outputs:

- Switching voltage: 12 to 250V AC or max. 30 V DC/0.5 A
- Max. continuous current: 10 mA to 2 A

### Built-in brake chopper

**Pulse encoder:** Connected to digital inputs DI4 and DI5, max. 25 V DC / 100 mA, max. pulse frequency 200 kHz

### Serial communication for external control:

- Modbus protocol as standard, other fieldbus options available: PROFIBUS-DP, InterBus-S, DeviceNet, CANOpen, LONWORKS<sup>®</sup>

## Programmable features \*)

### Nine application macros for easy configuration:

- Factory, ABB Standard, 3-Wire, Alternate, Motor Potentiometer, Hand-Auto, PID-Control, Pre-magnetize, Positioning

**Acceleration time:** 0.1 to 1800 s

**Deceleration time:** 0.1 to 1800 s

## Skip frequencies: Two bands

**Start and stop:** Flying start, Torque boosting, Premagnetising function, DC hold function, DC injection braking

## Functions:

- Output current and frequency limit, Programmable volts/herz ratio, IR compensation, Slip compensation, PID-control with sleep function, Seven preset speeds, Automatic fault reset, Two acceleration and two deceleration ramps, Control for electromechanical brake

## Protection

### Limits

- Over current trip limit:  $3.5 \cdot I_2$
- DC current regulation limit:  $0.5 \dots 1.5 \cdot I_2$
- DC over voltage trip limit: 875 V
- DC under voltage trip limit: 333 V
- Power-loss ride-through: 500 ms
- Over temperature limit: 105°C inside power module

### Inverter protection:

- Output short circuit, Input phase loss, Inverter overload, Output earth-fault, Serial communication error, Loss of AI signal, I/O terminal short circuit, Auxiliary voltage short circuit, Brake resistor overload

### Motor protection:

- Stall protection, Over temperature protection by  $R_t$  estimation or PTC thermistors.

## Environmental limits

### Ambient operating temperature:

- Output current =  $I_{2N}$  and  $f_{\text{switch}} = 4$  kHz: -10 to 40°C
  - Output current =  $0.7 \cdot I_{2N}$  and  $f_{\text{switch}} = 8$  kHz: -10 to 40°C
  - Output current =  $0.6 \cdot I_{2N}$  and  $f_{\text{switch}} = 8$  kHz: 40 to 50°C
  - Output current =  $I_{2NSQ}$  and  $f_{\text{switch}} = 4$  kHz: -10 to 40°C
  - Output current =  $0.7 \cdot I_{2NSQ}$  and  $f_{\text{switch}} = 8$  kHz: -10 to 40°C
  - Output current =  $0.6 \cdot I_{2NSQ}$  and  $f_{\text{switch}} = 8$  kHz: 40 to 50°C
- Refer to page 16 for more derating information

### Installation altitude:

- Output current =  $I_2$ : 0 to 1000 m
- Output current reduced by 1% for every 100 m above 1000 m. Max altitude 2000 m.

### Protection class: IP 65

**Colour:** NCS 1502-Y, RAL 9002, PMS 420 C

**Contamination levels:** According to IEC-721-3-3

## Electromagnetic Compatibility (EMC):

- Standard Drive: Fulfils EN 61800-3 2nd Environment distribution limits
- Drive with RFI filter: Fulfils EN 61800-3 1st and 2nd Environment distribution limits

## Harmonic emissions:

- Units with < 1 kW input power fulfil EN 61000-3-2
- Units with > 1 kW input power are to be used only in professional applications

## Product compliance

- Low Voltage Directive 73/23/EEC with amendments
- EMC Directive 89/336/EEC with amendments
- Quality Assurance systems ISO 9001 and ISO 14001
- CE, UL, cUL and C-Tick approvals

\*) *Adjustable only with control panel.*

# Frequency Converter Options

## IP 65 Control Panel Kit

Variant code: 611

Full configurable functionality is available when using the optional control panel. With the control panel, parameters can be exchanged between two drives using the parameter upload/download procedure.



## Fieldbus Gateways and RS485/232 Adapter

Variant code: see the table below

The integral motor can be connected to all major automation systems with the help of the large variety of fieldbuses. The fieldbus gateways are available in robust IP 65 boxes, which can be conveniently fitted on one side of the drive. The Modbus protocol is standard in all integral motor units and can be used by means of an RS485/232 adapter (CFB-RS).



### Fieldbus technical data

Fieldbus	Type code	Variant code	Protocol mode	Device profile	Baudrate (min.-max.)
PROFIBUS	CFB-PDP	612	DP	Profidrive V.2	9.6 kbits/s - 12 Mbits/s
InterBus-S	CFB-IBS	613	PCP	Drivecom (Profile 21)	500 kbits/s
DeviceNet	CFB-DEV	616	N.A.	AC Drive	125 - 500 kbits/s
CANOpen	CFB-CAN	614	N.A.	Drives and Motion control (DS402 V.1.1)	10 - 1000 kbits/s
LONWorks®	CFB-LON	615	LONTALK®	Variable Speed Motor Drive 6010	78 kbits
Modbus	CFB-RS	617	RTU	Vendor Specific	300 - 19200 bit/s

N.A. = Not applicable

## Integral Brake Resistors

Variant code: see the table below

The integral motor brake resistor offers an optimal solution for braking, as braking choppers are a standard feature of the drives. The IP 65 brake resistors can be fitted on one side of the integral motor.

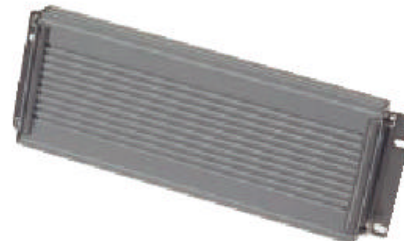

### Brake resistor technical data

Integral motor output kW (general purpose ratings)	Brake resistor Type code	Variant code	Resistance Ohm W	Max. average resistor power W	Max. instantaneous resistor power
0.37...0.55 kW	CA-BRK-R1-1	618	390	39	700
0.75 kW	CA-BRK-R1-1	618	390	39	950
1.1 kW	CA-BRK-R1-2	619	125	39	1500
1.5 kW	CA-BRK-R1-2	619	125	39	2100
2.2 kW	CA-BRK-R2	620	125	45	3080

## Cable gland set

Variant code: 230

A selection of cable glands for integral motor. The glands are for the following cable diameters: 5-9 mm (2 pcs), 6-12 mm (2 pcs) and 9-16 mm (2 pcs).



## More options for frequency converter available separately

- AnyBus Communicator fieldbus gateways (Profibus-DP and DeviceNet)
- DriveWindow Light 2 start-up and maintenance PC tool.

# General purpose integral motors

## Variant codes, motor part

S = Included as standard.  
 NA = Not applicable.  
 R = On request.  
 P = New manufacture only.

Code	Variant	Frame size			
		71	80	90	100
<b>Balancing</b>					
052	Balancing to grade R (IEC 60034-14).	P	P	P	P
423	Balanced without key.	P	P	P	P
424	Full key balancing.	P	P	P	P
<b>Bearings and lubrication</b>					
040	Heat resistant grease. ( -25 - +150°C)	P	P	P	P
042	Locked drive-end.	P	P	S	S
057	2RS bearings at both ends.	P	P	P	P
<b>Branch standard designs</b>					
178	Stainless steel/acid proof bolts.	P	P	P	P
425	Corrosion protected stator and rotor core.	P	P	P	P
<b>Cooling system</b>					
068	Metal fan.	P	P	P	P
183	Separate motor cooling (fan axial, N-end).	<b>P</b>	<b>P</b>	<b>P</b>	<b>P</b>
<b>Drain holes</b>					
065	Plugged drain holes.	P	P	NA	NA
066	Modified drain hole position.	P	P	P	P
076	Draining holes with plugs.	S	S	S	S
<b>Earthing bolt</b>					
067	External earthing bolt.	P	P	P	P
<b>Heating elements</b>					
450	Heating element, 100-120 V.	P	P	P	P
451	Heating element, 200-240 V.	P	P	P	P
<b>Mounting arrangements</b>					
007	IM 3001 flange mounted, IEC flange, from IM 1001 (B5 from B3).	P	P	P	P
008	IM 2101 foot/flange mounted, from IM 1001 (B34 from B3).	P	P	P	P
009	IM 2001 foot/flange mounted, from IM 1001 (B35 from B3).	P	P	P	P
047	IM 3601 flange mounted, IEC flange, from IM 3001 (B14 from B5).	P	P	P	P
048	IM 3001 flange mounted, IEC flange, from IM 3601 (B14 from B5).	P	P	P	P
<b>Painting</b>					
114	Special paint colour, standard grade. RAL-colour no. must be specified.	P	P	P	P

# General purpose integral motors

## Variant codes, motor part

S = Included as standard.  
 NA = Not applicable.  
 R = On request.  
 P = New manufacture only.

Code	Variant	Frame size			
		71	80	90	100
<b>Protection</b>					
005	Protective roof, vertical motor, shaft down.	P	P	P	P
073	Sealed against oil at D-end.	P	P	P	P
158	Degree of protection IP 65.	P	P	P	P
<b>Rating &amp; instruction plates</b>					
003	Individual serial number.	P	P	P	P
013	Restamping to output for class F temperature rise.	P	P	P	P
098	Stainless rating plate.	P	P	P	P
138	Mounting of additional identification plate, aluminium.	P	P	P	P
<b>Shaft &amp; Rotor</b>					
069	Two shaft extensions as per basic catalogue	P	P	P	P
165	Shaft extension with open key way	R	R	R	R
410	Stainless / acid proof steel shaft (standard or non-standard design)	P	P	P	P
<b>Standards and regulations</b>					
029	Fulfilling Underwriters Laboratory (UL) requirements	R	R	R	R
<b>Stator winding temperature sensors</b>					
436	PTC-thermistors (3 in series), 150°C	P	P	P	P
<b>Testing</b>					
140	Test confirmation	R	R	R	R
<b>Variable speed drives</b>					
470	Prepared for hollow shaft pulse tacho (L&L equivalent)	P	P	P	R
473	2048 pulse tacho (L&L equivalent)	P	P	P	R
477	Separate motor cooling (fan axial, N-end) and 2048 pulse tacho (L&L equivalent)	P	P	P	R

# General purpose integral motors

## Variant codes, frequency converter part

S = Included as standard.  
 NA = Not applicable.  
 R = On request.  
 P = New manufacture only.

Code	Variant	Frame size			
		71	80	90	100
<b>Unit body</b>					
230	Standard cable gland set	P	P	P	P
<b>Brake resistor</b>					
618	Inverter brake resistor for 0.37 kW, 0.55 kW & 0.75 kW unit (general purpose ratings)	P	P	P	NA
619	Inverter brake resistor for 1.1 kW & 1.5 kW unit (general purpose ratings)	NA	P	P	P
620	Inverter brake resistor for 2.2 kW unit (general purpose ratings)	NA	NA	P	P
<b>Panel kit</b>					
611	Inverter control panel kit	P	P	P	P
<b>Fieldbus type</b>					
612	CFB-PDP	P	P	P	P
613	CFB-IBS	P	P	P	P
614	CFB-CAN	P	P	P	P
615	CFB-LON	P	P	P	P
616	CFB-DEV	P	P	P	P
617	CFB-RS	P	P	P	P

## Derating Information

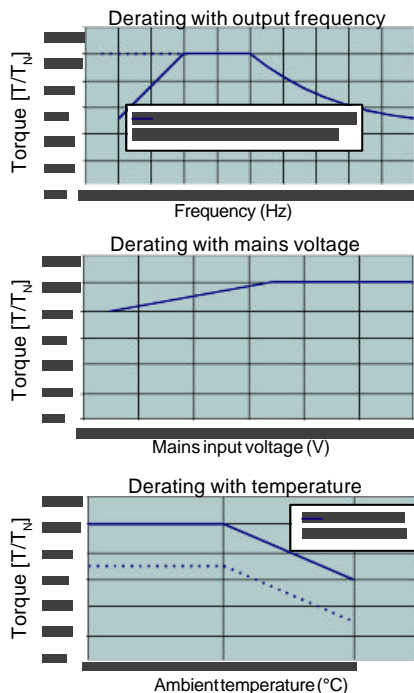

If the integral motor is used at low frequencies, separate cooling is recommended, particularly if the motor load is high and the speed is low.

M3VK



M3VK with separate cooling unit



Cooling unit



# General purpose integral motors

## Dimensions

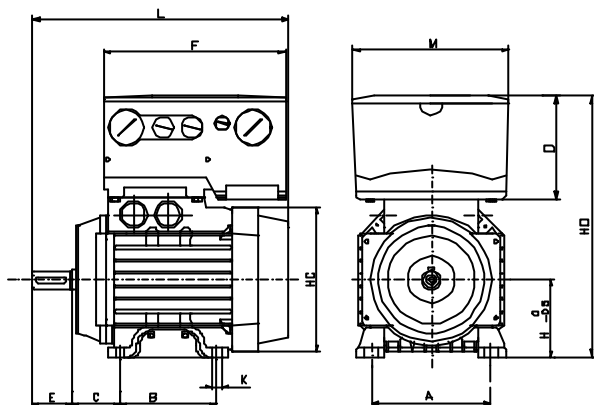

Dimensions with integrated options added

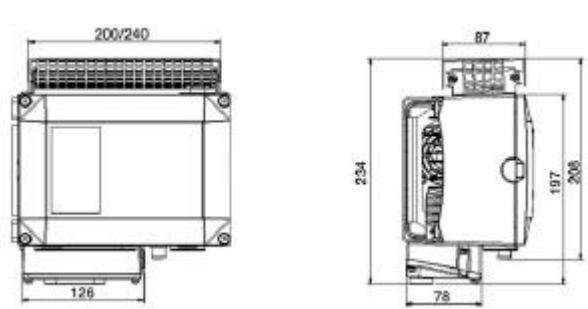

Integral Motor Standard Drive	Product Code Drive with RFI filter	Dimensions														
		A	B	C	E	H	HC	K	L	D std*	D w RFI*	HD std*	HD w RFI*	F	M	
3GVK 071 661-...C	3GVK 071 761-...C	112	90	45	30	71	130	7	283	110	146	261	297	221	171	
3GVK 071 662-...C	3GVK 071 762-...C	112	90	45	30	71	130	7	283	110	146	261	297	221	171	
3GVK 081 661-...C	3GVK 081 761-...C	125	100	50	40	80	150	10	275	110	146	280	316	221	171	
3GVK 081 662-...C	3GVK 081 762-...C	125	100	50	40	80	150	10	275	110	146	280	316	221	171	
3GVK 081 663-...C	3GVK 081 763-...C	125	100	50	40	80	150	10	275	110	146	280	316	221	171	
3GVK 091 661-...C	3GVK 091 761-...C	140	100	56	50	90	170	10	282	110	146	300	336	221	171	
3GVK 091 662-...C	3GVK 091 762-...C	140	125	56	50	90	170	10	307	110	146	300	336	261	171	
3GVK 072 662-...C	3GVK 072 762-...C	112	90	45	30	71	130	7	283	110	146	261	297	221	171	
3GVK 082 661-...C	3GVK 082 761-...C	125	100	50	40	80	150	10	275	110	146	280	316	221	171	
3GVK 082 662-...C	3GVK 082 762-...C	125	100	50	40	80	150	10	275	110	146	280	316	221	171	
3GVK 082 663-...C	3GVK 082 763-...C	125	100	50	40	80	150	10	275	110	146	280	316	221	171	
3GVK 092 661-...C	3GVK 092 761-...C	140	100	56	50	90	170	10	282	110	146	300	336	221	171	
3GVK 092 662-...C	3GVK 092 762-...C	140	125	56	50	90	170	10	307	110	146	300	336	221	171	
3GVK 102 661-...C	3GVK 102 761-...C	160	140	63	60	100	190	12	349	110	146	310	346	261	171	
3GVK 083 661-...C	3GVK 083 761-...C	125	100	50	40	80	150	10	275	110	146	280	316	221	171	
3GVK 083 662-...C	3GVK 083 762-...C	125	100	50	40	80	150	10	275	110	146	280	316	221	171	
3GVK 093 661-...C	3GVK 093 761-...C	140	100	56	50	90	170	10	282	110	146	300	336	221	171	
3GVK 093 662-...C	3GVK 093 762-...C	140	125	56	50	90	170	10	307	110	146	300	336	221	171	
3GVK 103 661-...C	3GVK 103 761-...C	160	140	63	60	100	190	12	349	110	146	310	346	221	171	

\* std = Standard Drive, w RFI = Drive with RFI filter



Integral Motor Standard Drive	Product Code Drive with RFI filter	Dimensions														
		A	B	C	E	H	HC	K	L	D std*	D w RFI*	HD std*	HD w RFI*	F	M	
3GVK 081 673-...C	3GVK 081 773-...C	125	100	50	40	80	150	10	275	110	146	280	316	221	171	
3GVK 091 672-...C	3GVK 091 772-...C	140	125	56	50	90	170	10	307	110	146	300	336	221	171	
3GVK 091 673-...C	3GVK 091 773-...C	140	125	56	50	90	170	10	307	110	146	300	336	261	171	
3GVK 092 672-...C	3GVK 092 772-...C	140	125	56	50	90	170	10	307	110	146	300	336	221	171	
3GVK 102 671-...C	3GVK 102 771-...C	160	140	63	60	100	190	12	349	110	146	310	346	221	171	
3GVK 102 673-...C	3GVK 102 773-...C	160	140	63	60	100	190	12	349	110	146	310	346	261	171	

\* std = Standard Drive, w RFI = Drive with RFI filter

# General purpose integral motors

## Dimensions in pump and fan use

Dimensions with integrated options added

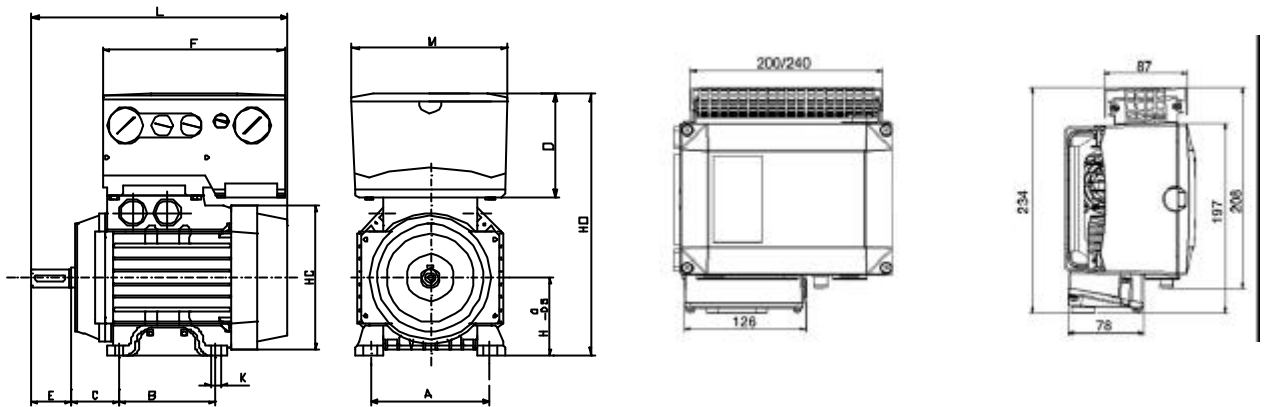

Integral Motor Standard Drive	Product Code Drive with RFI filter	Dimensions														
		A	B	C	E	H	HC	K	L	D std*	D w RFI*	HD std*	HD w RFI*	F	M	
3GVK 081 861-••C	3GVK 081 961-••C	125	100	50	40	80	150	10	275	110	146	280	316	221	171	
3GVK 081 862-••C	3GVK 081 962-••C	125	100	50	40	80	150	10	275	110	146	280	316	221	171	
3GVK 081 863-••C	3GVK 081 963-••C	125	100	50	40	80	150	10	275	110	146	280	316	221	171	
3GVK 091 861-••C	3GVK 091 961-••C	140	100	56	50	90	170	10	282	110	146	300	336	221	171	
3GVK 091 862-••C	3GVK 091 962-••C	140	125	56	50	90	170	10	307	110	146	300	336	221	171	
3GVK 101 861-••C	3GVK 101 961-••C	160	140	63	60	100	190	12	349	110	146	310	346	261	171	
3GVK 082 862-••C	3GVK 082 962-••C	125	100	50	40	80	150	10	275	110	146	280	316	221	171	
3GVK 092 861-••C	3GVK 092 961-••C	140	100	56	50	90	170	10	282	110	146	300	336	221	171	
3GVK 092 862-••C	3GVK 092 962-••C	140	125	56	50	90	170	10	307	110	146	300	336	221	171	
3GVK 102 861-••C	3GVK 102 961-••C	160	140	63	60	100	190	12	349	110	146	310	346	221	171	
3GVK 102 862-••C	3GVK 102 961-••C	160	140	63	60	100	190	12	349	110	146	310	346	261	171	

\* std = Standard Drive, w RFI = Drive with RFI filter

Integral Motor Standard Drive	Product Code Drive with RFI filter	Dimensions														
		A	B	C	E	H	HC	K	L	D std*	D w RFI*	HD std	HD w RFI*	F	M	
3GVK 081 873-••C	3GVK 081 973-••C	125	100	50	40	80	150	10	275	110	146	280	316	221	171	
3GVK 091 872-••C	3GVK 091 972-••C	140	125	56	50	90	170	10	307	110	146	300	336	221	171	
3GVK 091 873-••C	3GVK 091 973-••C	140	125	56	50	90	170	10	307	110	146	300	336	221	171	
3GVK 101 873-••C	3GVK 101 973-••C	160	140	63	60	100	190	12	349	110	146	310	346	261	171	
3GVK 092 872-••C	3GVK 092 972-••C	140	125	56	50	90	170	10	307	110	146	300	336	221	171	
3GVK 102 871-••C	3GVK 102 971-••C	160	140	63	60	100	190	12	349	110	146	310	346	221	171	
3GVK 102 873-••C	3GVK 102 973-••C	160	140	63	60	100	190	12	349	110	146	310	346	221	171	

\* std = Standard Drive, w RFI = Drive with RFI filter







# ABB Motors' total product offer

ABB offers several comprehensive ranges of AC motors and generators. We manufacture synchronous motors for even the most demanding applications, and a full range of low and high voltage induction motors. Our in-depth knowledge of virtually every type of industrial processing ensures we always specify the best solution for your needs.

## Low voltage motors and generators

### General purpose motors for standard applications

- Aluminium motors
- Steel motors
- Cast iron motors
- Open drip proof motors
- Brake motors
- Single phase motors
- Integral motors

### Process performance motors for more demanding applications

- Aluminium motors
- Cast iron motors

### Other applications

- Motors for hazardous areas
- Marine motors
- Permanent magnet motors
- High speed motors
- Wind turbine generators
- NEMA motors
- Water cooled motors
- Motors for roller table drives
- Slip ring motors
- Wood dryer motors
- Fan application motors

## High voltage and synchronous motors and generators

- High voltage cast iron motors
- Induction modular motors
- Slip ring motors
- Motors for hazardous areas
- Servomotors
- Synchronous motors and generators
- DC motors and generators

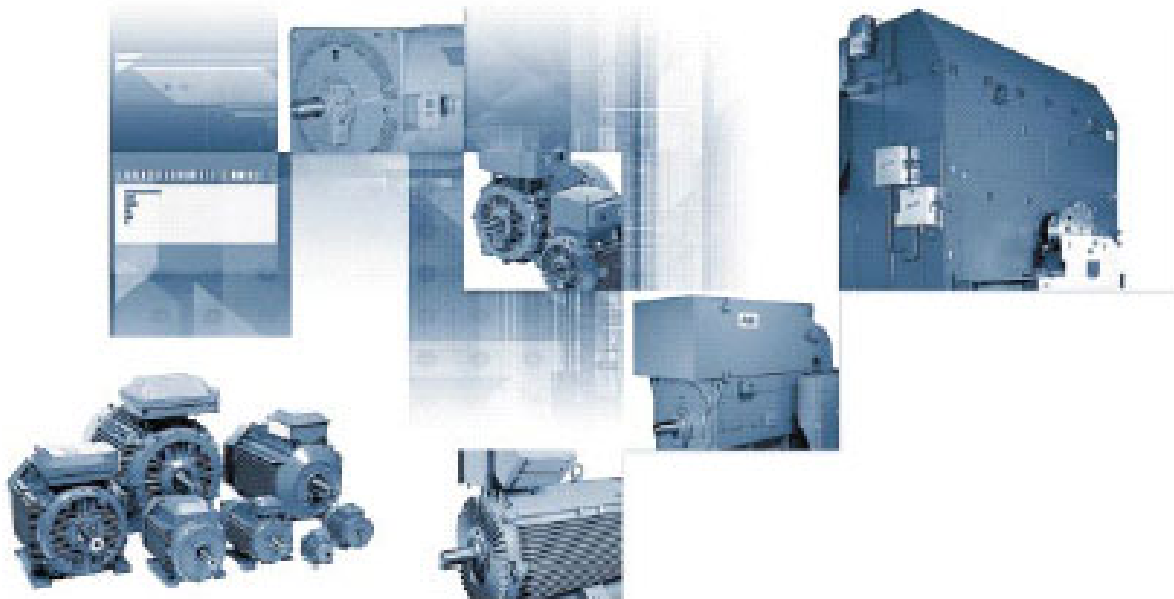

Address <http://www.abb.com/motors&drives>

**ABB**

About ABB Products & Services Sustainability News Center Technology Careers Investor Relations

**Motors & Drives**

Go to The ABB Product Guide  
AC Drives +  
Low Voltage Motors +  
Range of products as  
Library of Documents +  
Local contact  
Motor availability +  
Wind Turbine Generators  
Drives Service Products +  
DC Drives +  
DC Motors +  
Servomotors +  
Power Electronics Systems +  
Motorformer  
Contact ABB

## Low Voltage Motors

**ABB is offering a market platform of low voltage motors second to none quality, reliability and performance. Motors for every application - Making you more competitive.**

With a broader range of products and services ABB low voltage motors is years ahead of competition. We provide energy efficient, reliable motors with excellent services and options for online ordering via BusinessOnline, a personalized service for ordering motors and drives. Availability is guaranteed by the global central stock concept.

SEARCH

LINKS

- + Range of products
- + Library of Documents
- + Online ordering of motors and drives

Printer version Email this page Bookmark this page

Provider information/Impressum © Copyright 2003 ABB. All rights reserved.

- Motors & Drives**
- => Low Voltage Motors
  - => Range of Products
  - => **General purpose motors**
    - Aluminium motors
    - Steel motors
    - Cast iron area motors
    - Open drip proof motors
    - Brake motors
    - Single phase motors
    - Integral motors
  - Process performance motors
  - Motors for hazardous areas
  - Marine motors
  - Roller table motors
  - Water cooled motors
  - Permanent magnet motors
  - High speed motors
  - Wind turbine generators
  - Library of documents
  - => Technical documents
  - Local contacts

**ABB**

About ABB Products & Services Sustainability News Center Technology Careers Investor Relations

Industry Portals ABB Product Guide Service Guide Contact Directory Industrial IT Supplying to ABB

**Motors & Drives**

Go to The ABB Product Guide  
AC Drives +  
Low Voltage Motors +  
High Voltage Motors +  
Motors for Hazardous Areas +  
Synchronous Motors +  
Synchronous Generators +  
Wind Turbine Generators  
Drives Service Products +  
DC Drives +  
DC Motors +  
Servomotors +  
Power Electronics Systems +  
Motorformer  
Contact ABB

## Low Voltage Induction Motors Ranges

General purpose motors	Process performance motors
Designed for standard applications, perfect for OEM's.	Engineered for meeting process industry's exacting demands.
Aluminium motors Steel motors Cast iron motors Open drip proof motors Brake motors Single-phase motors Integral motors	Cast iron motors Aluminium motors
<b>Motors for hazardous areas</b> Available for all protection types	<b>Marine motors</b> All major classification societies certified
Motors for hazardous areas	Marine motors
<b>Other applications</b>	
Premium efficiency motors Smoke venting motors Permanent magnet motors High speed motors	Fan application motors Roller table motors Water-cooled motors

SEARCH

CONTACT US

Sales information:  
- Please select country -

LINKS:

- + Library of Documents
- + Technical documents - drawings, certificates etc.
- + Online ordering of motors and drives
- + Product training

**ABB**

About ABB Products & Services Sustainability News Center Technology Careers Investor Relations

Industry Portals ABB Product Guide Service Guide Contact Directory Industrial IT Supplying to ABB

**Motors & Drives**

Go to The ABB Product Guide  
AC Drives +  
Low Voltage Motors +  
Range of products as  
Library of Documents +  
Local contact  
Motor availability +  
Wind Turbine Generators  
Drives Service Products +  
DC Drives +  
DC Motors +  
Servomotors +  
Power Electronics Systems +  
Motorformer  
Contact ABB

## Low voltage motors - Library of documents and software

SEARCH

CONTACT US

Sales information:  
- Please select country -

LINKS:

- + Range of products
- + Document Library
- + Technical documents
- + DriveSize/MotSize 2.0 Software
- + FactFiles

**Browse Document Library - click here**

The Motor Guides  
Brochures and technical catalogues  
Manuals  
FactFiles  
Environmental product declarations

**Technical documents - click here**

CAD outline drawings  
Dimension drawings  
Certificates

**Software - click here**

DriveSize/MotSize 2.0

Printer version Email this page Bookmark this page

Provider information/Impressum © Copyright 2003 ABB. All rights reserved.

# Drive<sup>IT</sup> Low Voltage Motors

Manufacturing sites (\*) and some of the larger sales companies.

## Australia

ABB Industry Pty Ltd  
2 Douglas Street  
Port Melbourne,  
Victoria, 3207  
Tel: +61 (0) 3 9644 4100  
Fax: +61 (0) 3 9646 9362

## Austria

ABB AG  
Wienerbergstrasse 11 B  
A-1810 Wien  
Tel: +43 (0) 1 601 090  
Fax: +43 (0) 1 601 09 8305

## Belgium

Asea Brown Boveri S.A.-N.V.  
Hoge Wei 27  
B-1930 Zaventem  
Tel: +32 (0) 2 718 6311  
Fax: +32 (0) 2 718 6657

## Canada

ABB Inc., BA Electrical Machines  
10300 Henri-Bourassa Blvd,  
West, Saint-Laurent, Quebec  
Canada H4S 1N6  
Tel: +1 514 832-6583  
Fax: +1 514 332-0609

## China\*

ABB Shanghai Motors  
Company Limited  
8 Guang Xing Rd., Rong Bei  
Town, Songjiang County,  
Shanghai 201613  
Tel: +86 21 5778 0988  
Fax: +86 21 5778 1364

## Chile

Asea Brown Boveri S.A.  
P.O.Box 581-3  
Santiago  
Tel: +56 (0) 2 5447 100  
Fax: +56 (0) 2 5447 405

## Denmark

ABB A/S  
Automation Technology Electrical  
Machines  
Petersmindevej 1  
DK-5000 Odense C  
Tel: +45 65 477 070  
Fax: +45 65 477 713

## Finland\*

ABB Oy  
LV Motors  
P.O.Box 633  
FIN-65101 Vaasa  
Tel: +358 (0) 10 22 11  
Fax: +358 (0) 10 22 47372

## France

ABB Automation  
Rue du Général de Gaulle  
Champagne-sur-Seine  
F-77811 Moret-sur-Loing Cedex  
Tel: +33 (0) 1 60 746 500  
Fax: +33 (0) 1 60 746 565

## Germany

ABB Automation Products  
GmbH  
Edisonstrasse 15  
68623 Lampertheim  
3 Dai Hei Street,  
Tel: +49 (0) 6206 503 503  
Fax: +49 (0) 6206 503 600

## Hong Kong

ABB (Hong Kong) Ltd.  
Tai Po Industrial Estate,  
3 Dai Hei Street,  
Tai Po, New Territories,  
Hong Kong  
Tel: +852 2929 3838  
Fax: +852 2929 3505

## India\*

ABB Ltd.  
32, Industrial Area, N.I.T  
Faridabad 121 001  
Tel: +91 (0) 129 502 3001  
Fax: +91 (0) 129 502 3006

## Indonesia

PT. ABB Sakti Industri  
JL. Gajah Tunggal Km.1  
Jatuiwung, Tangerang 15136  
Banten, Indonesia  
Tel: + 62 21 590 9955  
Fax: + 62 21 590 0115 - 6

## Ireland

Asea Brown Boveri Ltd  
Components Division  
Belgard Road  
Tallaght, Dublin 24  
Tel: +353 (0) 1 405 7300  
Fax: +353 (0) 1 405 7327

## Italy\*

ABB SACE SpA  
LV Motors  
Via Della Meccanica, 22  
I-20040 Caponago - MI  
Tel: +39 02 959 6671  
Fax: +39 02 959 667216

## Japan

ABB K.K.  
26-1 Cerulean Tower  
Sakuragaoka-cho, Shibuya-ku  
Tokyo 150-8512  
Tel: +81 (0) 3 578 46251  
Fax: +81 (0) 3 578 46260

## Korea

ABB Korea Ltd.  
7-9fl, Oksan Bldg., 157-33  
Sungshung-dong, Kangnam-ku  
Seoul  
Tel: +82 2 528 2329  
Fax: +82 2 528 2338

## Malaysia

ABB Malaysia Sdn. Bhd.  
Lot 608, Jalan SS 13/1K  
47500 Subang Jaya, Selangor  
Tel: +60 3 5628 4888  
Fax: +60 3 5631 2926

## Mexico

ABB México, S.A. de C.V.  
Apartado Postal 111  
CP 54000 Tlalnepantla  
Edo. de México, México  
Tel: +52 5 328 1400  
Fax: +52 5 390 3720

## The Netherlands

ABB B.V.  
Dept. LV motors (APP2R)  
P.O.Box 301  
NL-3000 AH Rotterdam  
Tel: +31 (0) 10 4078 879  
Fax: +31 (0) 10 4078 345

## Norway

ABB AS  
Automation Technology Products  
Division  
P.O.Box 6540 Rodeloekka  
N-0501 Oslo 5  
Tel: +47 22 872 000  
Fax: +47 22 872 541

## Singapore

ABB Industry Pte Ltd  
2 Ayer Rajah Crescent  
Singapore 139935  
Tel: +65 6776 5711  
Fax: +65 6778 0222

## Spain\*

ABB Automation Products S.A.  
Division Motores  
P.O.Box 81  
E-08200 Sabadell  
Tel: +34 93 728 8500  
Fax: +34 93 728 8741

## Sweden\*

ABB Automation Technology  
Products AB  
Motors & Machines  
LV Motors  
S-721 70 Västerås  
Tel: +46 (0) 21 329 000  
Fax: +46 (0) 21 124 103

## Switzerland

ABB Schweiz AG  
Normelec/CMC Components  
Motors&Drives  
Badenerstrasse 790  
Postfach  
CH-8048 Zürich  
Tel: +41 (0) 58 586 0000  
Fax: +41 (0) 58 586 0603

## Taiwan

ABB Ltd.  
6F, No. 126, Nanking East  
Road, Section 4  
Taipei, 105 Taiwan, R.O.C.  
Tel: +886 (0) 2 2577 6090  
Fax: +886 (0) 2 2577 9467

## Thailand

ABB Limited (Thailand)  
161/1 SG Tower,  
Soi Mahadlekluang 3,  
Rajdamri, Bangkok 10330  
Tel: +66 2 665 1000  
Fax: +66 2 6042

## The United Kingdom

ABB Automation Ltd  
9 The Towers, Wilmslow Road  
Didsbury  
Manchester, M20 2AB  
Tel: +44 (0) 161 445 5555  
Fax: +44 (0) 161 448 1016

## USA

ABB Inc.  
Electrical Machines  
P.O.Box 372  
Milwaukee  
WI 53201-0372  
Tel: +1 262 785 3200  
Fax: +1 262 785 8628

## Venezuela

Asea Brown Boveri S.A.  
P.O.Box 6649  
Carmelitas,  
Caracas 1010A  
Tel: +58 (0) 2 238 2422  
Fax: +58 (0) 2 239 6383



<http://www.abb.com/motors&drives>  
<http://online.abb.com/motors&drives>