

# Thermal Overload relays

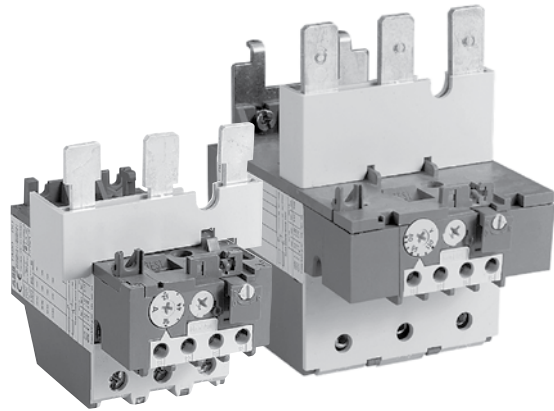

## Thermal overload relays

Type TA  
Class 10  
Class 20



### Description

- Available for starter construction with A Line contactors and separate panel mounting
- Designed for close couple mounting
- Separate base mounting available for all overload relays
- Class 10 adjustable overload relays are standard with all ABB Line starters
- Reset can also be adjusted to function as a stop button
- Screwdriver guide holes
- All terminal screws are available from the front
- UL File No: E48139
- CSA File No: LR98336
- Trip indication
- Remote trip and reset option available
- Single phase and phase unbalance protection
- Isolated alarm circuit (N.O.) contact
- Ambient compensation: -25°C to +55°C (-13°F to +131°F)
- Manual test
- Manual or automatic reset
- Factory calibrated and tested
- Wide adjustment range

### Tripping classes of the thermal overload relays

Standard classes in IEC 947-4-1 are classes: 10 A, 10, 20, 30. The tripping class indicates according to IEC 947-4-1 the maximum tripping time in seconds under specified conditions of test at 7.2 times the setting current and specifies tripping and non tripping times for 1.5 and 7.2 times the setting current. Mostly used class is 10 A.

### Abstract from IEC 947-4-1

Tripping class	10 A	10	20	30
Max. tripping time at 1.5 x setting current (warm state) (s)	120	240	480	720
Tripping time at 7.2 x setting current (cold state) (s)	2 – 10	4 – 10	6 – 20	9 – 30
At 1.05 x setting current	no tripping			

TA thermal overload relays are used with A Line contactors for the protection of motors having a nominal voltage of up to 600VAC max per UL/CSA (690VAC and 800VDC per IEC).

### Product range

#### • Standard relays:

Types: TA25DU, TA42DU, TA75DU, TA80DU, TA110DU, TA200DU and TA450DU

- TA25 to TA110 and TA200 are directly connected in the motor circuit.
- TA450DU relays are fed through a linear type transformer

#### • Special construction

Thermal overload relays with different certifications and approvals. Relays for protection EEx e motors.

### Construction and function

#### • General

Thermal O/L relays and their accessories meet UL, CSA and most other important international standards (IEC), European standards (EN) and the most important national standards (DIN-VDE, NFC-UTE, BS, etc.). They meet the certification and approval directives required throughout the world.

Thermal overload relays are 3 pole. The motor current flows through their bimetals (1 per phase) which are indirectly heated. Under the effect of the heating, the bimetals bend, cause the relay to trip and the position of the auxiliary contacts to change.

The relay setting range is graduated in amps. In compliance with international and national standards, the setting current is the motor nominal current and not the tripping current (no tripping at 1.05 x setting current, tripping at 1.2 times setting current).

The tripping curves (cold or warm starting, 3 phases and 2 phases) are shown on page 2.14.

The relays are built to be self protecting in the event of an overload until the short circuit protection device is activated.

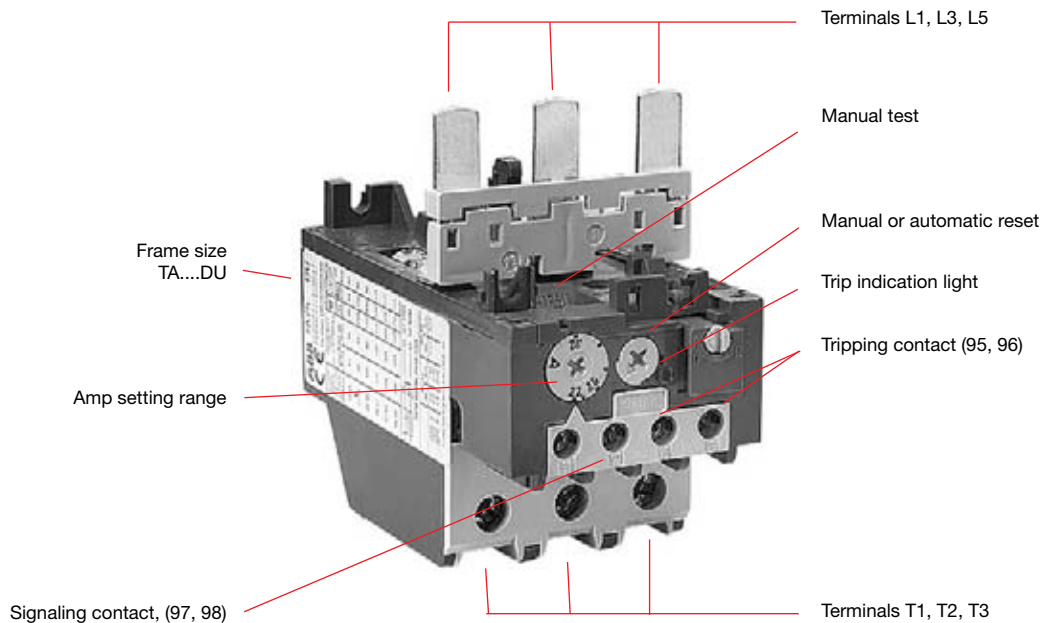



TA25DU

## Application

### Technical data

• **All the relays have:**

- Free tripping: the resetting button, even if held in, does not prevent tripping of the thermal overload relay in the event of a fault.
- Temperature compensation
- Phase failure protection according to IEC 947-4-1: Within the limits of the setting range, a reduced tripping time, and thus improved motor protection, is obtained in case of a phase failure.
- Tripping class: 10A, for TA relays
- Test functions and resetting: see table below.

• **Auxiliary contacts**

The relays have two built in auxiliary contacts: NC marked 95-96; NO marked 97-98. Both contacts are physically separate and can thus be used for 2 different circuits (control circuit and indication circuit).

### Function of TA25DU – TA450DU thermal O/L relays

	Resetting Contacts	Relay tripped		Relay not tripped
		Manual	Automatic	
Effect of blue button indexed on R (RESET ONLY)	Resetting	Yes	No	No
	95-96	Closed when the button is pressed	No effect	No effect
	97-98	Open when the button is pressed		
Effect of blue button indexed on R/O (RESET/OFF)	Resetting	Yes	No	No
	95-96	Closed when the button is released	No effect	Open when the button is pressed Closed when the button is released
	97-98	Open when the button is pressed		No effect

## Selection guide TA25DU – TA80DU

2



TA25DU



TA42DU



TA75DU



TA80DU

### Types

### Main characteristics

<b>Construction</b>	3 pole with ambient temperature variation compensation. Protection against single phase operation. Built in auxiliary contacts: 1N.O. + 1N.C.			
---------------------	--	--	--	--

<b>Resetting</b>	Convertible: Manual to Automatic			
------------------	----------------------------------	--	--	--

<b>Setting ranges</b>	Number	18	3	6	4
	from to	0.1 – 0.16A 24 – 32A	18 – 25A 29 – 42A	18 – 25A 60 – 80A	29 – 42A 60 – 80A

### Mounted with contactors

<b>Mounting kit</b>	No kit is required for mounting thermal O/L relays below contactors			
Types of contactors for combined mounting	A/AE/AL9 A/AE/AL12 A/AE/AL16			
	A/AE/AL26 A/AE/AL30 A/AE/AL40	A/AE30 A/AE40		
			A/AE/AF50 A/AE/AF63 A/AE/AF75	A/AE/AF95 A/AE/AF110

### Mounted separately (i.e. separate from contactor)

Separate mounting kit	DB25	DB80
-----------------------	------	------

### Accessories

Tripping coil	DS25-A	
Resetting coil	DR25-A	
Terminal shroud	Terminals protected against direct contact (without the addition of terminal shrouds)	
Function markers	BA5-50	

# Selection guide TA110DU – TA450DU

Thermal  
Overload  
relays

2

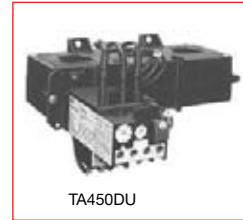
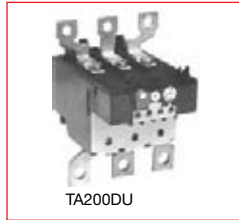
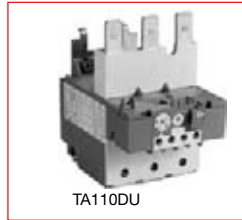

## Types

### Main characteristics

<b>Construction</b>	3 pole with ambient temperature variation compensation. Protection against single phase operation. Built in auxiliary contacts: 1N.O. + 1N.C.		

<b>Resetting</b>	Convertible: manual to automatic			
<b>Setting ranges</b>	Number	2	6	3
	from A	65 – 90	65 – 90	130 – 185
	to A	80 – 110	150 – 200	220 – 310

### Mounted with contactors

<b>Mounting kit</b>	No kit is required for mounting thermal O/L relays		See page 2.7.	
Types of contactors for combined mounting				
	A/AE/AF95 A/AE/AF110			
	A/AF145 A/AF185		A/AF210 + DT450/A300 A/AF260 + DT450/A300 A/AF300 + DT450/A300	
<b>Mounted separately</b> (i.e. separate from contactor)	DB200		No kit required for separate mounting of thermal O/L relays	
Separate mounting kit				

### Accessories

Tripping coil			
Resetting coil			
Terminal shroud	⓪	LT200 –	LT450 –
Function markers		BA5-50	

⓪ Terminals protected against direct contact (without the addition of terminal shrouds)

## TA25 - TA450

### Class 10

### for Contactors A9 – A/AF300

2



TA25DU



TA42DU



TA75DU



TA80DU



TA110DU

For Contactor	Setting Range A	Suffix Code	Catalog Number	List Price
A/AE/AL9 – A/AE/AL40	0.1 - 0.16	A	TA25DU0.16	\$ 63
	0.16 - 0.25	B	TA25DU0.25	
	0.25 - 0.4	C	TA25DU0.4	
	0.4 - 0.63	D	TA25DU0.63	
	0.63 - 1.0	E	TA25DU1.0	
	1.0 - 1.4	F	TA25DU1.4	
	1.3 - 1.8	G	TA25DU1.8	
	1.7 - 2.4	H	TA25DU2.4	
	2.2 - 3.1	J	TA25DU3.1	
	2.8 - 4.0	K	TA25DU4.0	
	3.5 - 5.0	L	TA25DU5.0	
	4.5 - 6.5	M	TA25DU6.5	
	6.0 - 8.5	N	TA25DU8.5	
	7.5 - 11	P	TA25DU11	
10 - 14	Q	TA25DU14		
13 - 19	R	TA25DU19		
18 - 25	S	TA25DU25		
24 - 32	T	TA25DU32		
A/AE30 - A/AE/40	18 - 25	A	TA42DU25	78
	22 - 32	B	TA42DU32	
	29 - 42	C	TA42DU42	
A/AE/AF50 - A/AE/AF75	18 - 25	A	TA75DU25	102
	22 - 32	B	TA75DU32	
	29 - 42	C	TA75DU42	
	36 - 52	D	TA75DU52	
	45 - 63	E	TA75DU63	
	60 - 80	F	TA75DU80	
A/AE/AF95 - A/AE/AF110	29 - 42	C	TA80DU42	135
	36 - 52	D	TA80DU52	
	45 - 63	E	TA80DU63	
	60 - 80	F	TA80DU80	
	65 - 90	A	TA110DU90	
	80 - 110	B	TA110DU110	
A/AF145 - A/AF185	65 - 90	A	TA200DU90	225
	80 - 110	B	TA200DU110	
	100 - 135	C	TA200DU135	
	110 - 150	D	TA200DU150	
	130 - 175	E	TA200DU175	
	150 - 200	F	TA200DU200	
A/AF210 - A/AF300	130 - 185	A	TA450DU185 ①	488
	165 - 235	B	TA450DU235	
	220 - 310	C	TA450DU310	
AF400 - AF750	See electronic overloads, pages 2.21			

① TA450 overloads require mounting kits for installation.

# TA25 - TA80

## Class 20

### for Contactors A9 - A80

Thermal  
Overload  
relays

2



TA25DU



TA42DU



TA75DU



TA80DU

Setting range A ... A	Suffix	Packing unit piece	Reference code	Catalog number	List price
<b>TA25DU trip class 20 for contactors A9 ... A40 and (T) AL9 ... (T) AL30</b>					
1.3 ... 1.8	GZ	1	1SAZ211401R1025	TA25DU1.8-20	\$ 63
1.7 ... 2.4	HZ	1	1SAZ211401R1028	TA25DU2.4-20	
2.2 ... 3.1	JZ	1	1SAZ211401R1031	TA25DU3.1-20	
2.8 ... 4.0	KZ	1	1SAZ211401R1033	TA25DU4.0-20	
3.5 ... 5.0	LZ	1	1SAZ211401R1035	TA25DU5.0-20	
4.5 ... 6.5	MZ	1	1SAZ211401R1038	TA25DU6.5-20	
6.0 ... 8.5	NZ	1	1SAZ211401R1040	TA25DU8.5-20	
7.5 ... 11	PZ	1	1SAZ211401R1043	TA25DU11-20	
10 ... 14	QZ	1	1SAZ211401R1045	TA25DU14-20	
13 ... 19	RZ	1	1SAZ211401R1047	TA25DU19-20	
18 ... 25	SZ	1	1SAZ211401R1051	TA25DU25-20	
24 ... 32 <sup>(1)</sup>	TZ	1	1SAZ211401R1053	TA25DU32-20 <sup>(1)</sup>	

<sup>(1)</sup> with terminal block DX25: 1x16mm<sup>2</sup>

<b>TA42DU trip class 20 for contactors A30, A40 and (T) AL30, (T) AL40</b>					
18 ... 25	AZ	1	1SAZ311401R1001	TA42DU25-20	\$ 78
22 ... 32	BZ	1	1SAZ311401R1002	TA42DU32-20	
29 ... 42	CZ	1	1SAZ311401R1003	TA42DU42-20	

<b>TA75DU trip class 20 for contactors A50 ... A75 and AE50 ... AE75</b>					
18 ... 25	AZ	1	1SAZ321401R1001	TA75DU25-20	\$ 102
22 ... 32	BZ	1	1SAZ321401R1002	TA75DU32-20	
29 ... 42	CZ	1	1SAZ321401R1003	TA75DU42-20	
36 ... 52	DZ	1	1SAZ321401R1004	TA75DU52-20	
45 ... 63	EZ	1	1SAZ321401R1005	TA75DU63-20	
60 ... 80	FZ	1	1SAZ321401R1006	TA75DU80-20	

<b>TA80DU trip class 20 for contactors A95, A110, AE 95 and AE110</b>					
29 ... 42	AZ	1	1SAZ331401R1003	TA80DU42-20	\$ 135
36 ... 52	BZ	1	1SAZ331401R1004	TA80DU52-20	
45 ... 63	CZ	1	1SAZ331401R1005	TA80DU63-20	
60 ... 80	DZ	1	1SAZ331401R1006	TA80DU80-20	

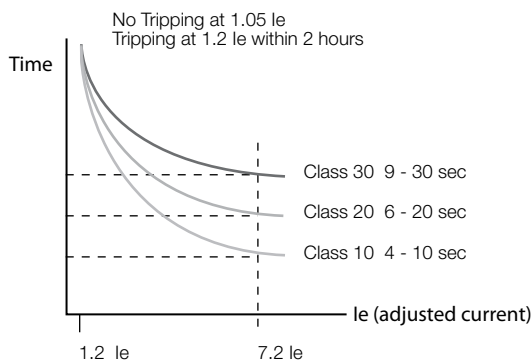



DB25/25A



DB80



DB200

**Separate mounting kits**

For O/L relays	Amps	Catalog number	List price
TA25DU	0.1 – 25	DB25/25A	<b>\$ 30</b>
TA25DU	24 – 32	DB25/32A	<b>38</b>
TA42DU, TA75DU, TA80DU	18 – 80	DB80	<b>45</b>
TA110DU, TA200DU	100 – 200	DB200	<b>60</b>

**Terminal block – AWG #8 cable**

Mounting on:	Catalog number	List price
TA25DU (25A or less) or DB25/25A	DX25	<b>\$ 15</b>

LC terminal blocks can be used to convert standard connections into Faston connections: 2 x 6.3mm or 4 x 2.8mm per pole. The connections are protected against accidental contact.

The LC30-T has a terminal block for the 3 power terminals and a second for the 4 auxiliary terminals of a TA25DU thermal O/L relay.

The LC26-B1 has two identical terminal blocks each for 3 power terminals. This block allows the power terminals to be mounted with two DB25 kits or a TA25DU thermal O/L relay and DB25 kit assembly.

NOTE: According to DIN 46429 part 1 and NFC 20-120 the max. capacity of a Faston connection is 25 A.

**Mounting kit – for TA450 overload relay**

For contactor	Catalog number	List price
A145 – A185	DT450/A185	<b>\$ 225</b>
A210 – A300	DT450/A300	

**Terminal shrouds – for contactors and overload relays**

Contactor	Overload relay	Catalog number	List price
A9 – A16 A26 – A40	TA25DU	Included	–
A30 – A40	TA42DU	Included	–
A50 – A75	TA75DU	Included	–
A95 – A110	TA80DU TA110DU	Included	–
A145 – A185	TA200DU	LT185-AY	<b>\$ 10</b>
A145 – A185	Load side of TA200DU	LT200A185	<b>50</b>

**Terminal lug kits**

Wire range	For overloads	Catalog number	List price
6 – 250MCM	TA110DU, TA200DU	EHTK210	<b>\$ 45</b>
4 – 400MCM	TA450DU185	ATK300HK	<b>78</b>
(2) 4 – 500MCM	TA450DU310	ATK300/2HK	<b>120</b>

Discount schedule ABA [OF] – A-contactor accessories

Discount schedule TAA [OW] – TA25

Discount schedule TBA [OX] – TA42, TA75

Discount schedule TCA [OY] – TA80, TA110, TA200, TA450



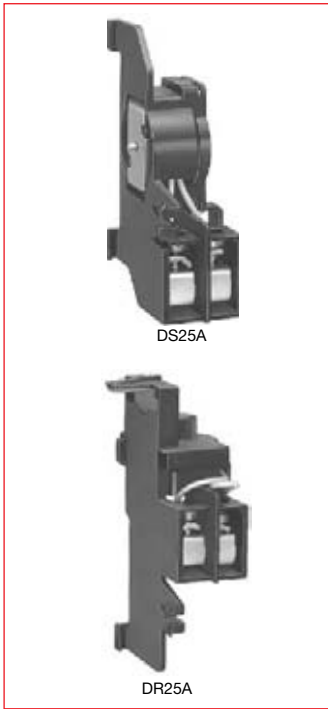

## Remote tripping coils

	U voltage at 50/60 Hz	Catalog number ①	List price
DS25-A remote tripping coil	24V	DS25-A-24 DS25-A-48 DS25-A-110 DS25-A-220/380 DS25-A-500	\$ 60
	48V		
	110V		
	220/380V		
	500V		
DS25-A remote resetting coil	24V	DR25-A-24 DR25-A-48 DR25-A-110 DR25-A-220/380 DR25-A-500	
	48V		
	110V		
	220/380V		
	500V		

## Application

• The DS25-A coil is used for remote electrical tripping of the TA25 DU thermal O/L relay and is connected to the relay's normally closed 95-96 auxiliary contact.

• The DR 25-A coil is used for remote electrical resetting of the TA25DU thermal O/L relay which is adjusted for "Manual resetting;" it is connected to the relay's normally open 97-98 auxiliary contact.

**The coils are not designed for continuous duty. Impulse duration: 0.2 to 0.35 s.**

Set the button to "Man" (Manual resetting).

Mounting: clipped on to TA25DU thermal O/L relay.

## Installation diagrams

### For connection of DS25-A to TA25DU relay

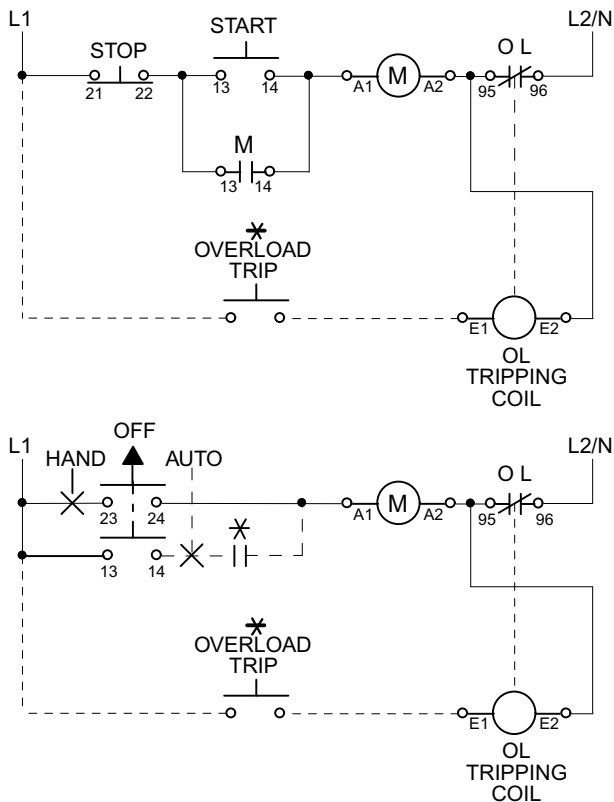

### For connection of DR25-A to TA25DU relay

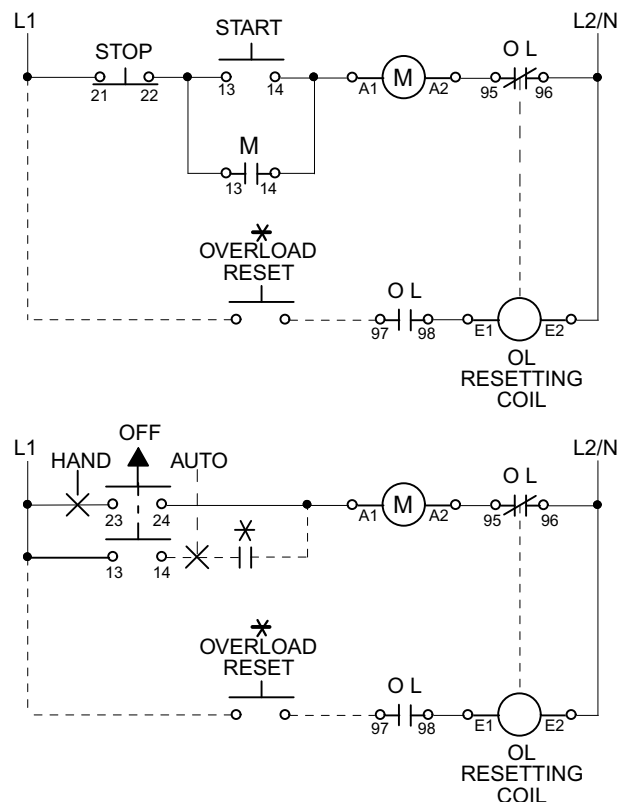

① Cannot be used with TA42, TA75, or TA200 overload relays.

### Intermittent duty

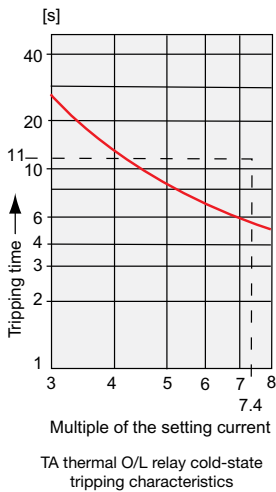
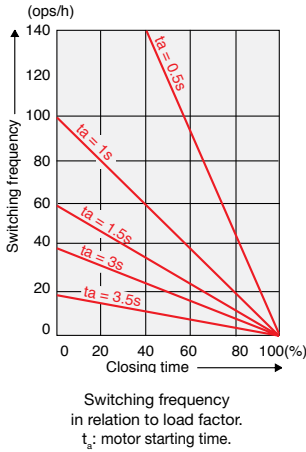

### Switching frequency:

To avoid untimely tripping, TA and T thermal O/L relays have been designed to withstand roughly 15 switching operations per hour with an approximately equal distribution between working and rest cycles.

In these conditions, the motor starting time must not exceed 1 second and the starting current must be lower than or equal to 6 times the motor  $I_n$ .

For intermittent operations, the diagram opposite specifies relay operating limits.

**Example:** Motor starting time: 1 sec.  
Load factor: 40 %  
Switching frequency: 60 ops./h according to diagram

For a higher number of operations and for load variations (e.g. frequent starting and braking), it is advisable to use CUSTORAPID® protection.

For motors subject to particularly severe operating conditions (e.g. locked rotor) it is advisable to use protection combined with a thermal O/L relay and the CUSTORAPID® system.

### Protection of motors with long starting time

See electronic overload relay section, pages 2.21 - 2.32.

### Mounting position

On a support at an angle of  $\pm 30^\circ$  in relation to the vertical plane (standard position).

Other mounting positions possible, except mounting on a horizontal plane (in this case the tripping mechanism would be located above the bimetals).

### Special version for EEx e motors

Consult factory.

### Tripping limits at ambient temperatures varying by $+ 20^\circ\text{C}$

#### Ambient temperature compensation

Thermal O/L relays are compensated against ambient temperature variations by a compensation bimetal which is sensitive to the ambient temperature.

Thermal O/L relays are designed to operate between  $-5^\circ\text{C}$  and  $+40^\circ\text{C}$  in compliance with standard IEC 947-4-1. For a wider range of  $-25^\circ\text{C}$  to  $+55^\circ\text{C}$  consult the graph opposite.

**Example:** tripping at  $-25^\circ\text{C}$ . Tripping takes place before 1.5 times the setting current.

**Resetting:** TA25DU – TA450 DU thermal O/L relays have convertible manual/automatic resetting.

**Delivery:** in manual resetting mode.

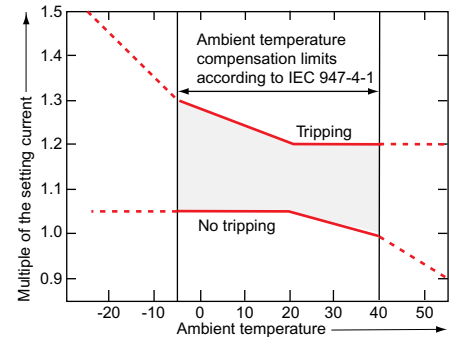

# Technical data

## TA25DU – TA80DU

Thermal  
Overload  
relays

2

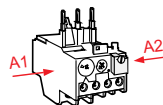
Types	TA25DU	TA42DU	TA75DU	TA80DU	
Standards: (international, European)	IEC 947-4-1, EN 60947-4-1				
Rated insulation voltage $U_i$ according to IEC 947-4-1	V	690			
Rated impulse withstand voltage $U_{imp}$ according to IEC 947-4-1	kV	6			
Permissible ambient temperature – for storage – for operation	°C °C	–40 to +70 –25 to +55 with temperature compensation (maximum values: see page 2.9)			
Climatic withstand DIN 50017	Humidity in alternate climate KFW, 30 cycles				
Mounting positions	On a support at an angle of $\pm 30^\circ$ in relation to the vertical plane (standard position). Other positions possible except mounting on a horizontal plane (in this case the tripping mechanism would be located above the bimetals).				
Shock withstand at nominal $I_e$ Critical direction of shocks A1, A2	shock duration ms multiples of g	15 12			
Resistance to vibrations ( $\pm 1$ mm, 50 Hz)	multiples of g 8				
Mounting – on contactor – separate with DB - kit	Latching below the contactor, screw fixing on main terminals Using screws: 2 x M4 or 35 mm EN 50022				
Terminals and cross-sectional areas for main conductors (motor side)		TA25DU setting ranges: from 0.1-0.16A 24-32 A to 18-25A			
• screw terminal – with cable clamp – via tunnel connector – flat type for lug or bar		M4 – –	– M5 –	M6 –	M6 –
• conductor cross-sectional area – rigid solid or rigid stranded – flexible with cable end – recommended bars		mm <sup>2</sup> mm <sup>2</sup> mm	2 x 1.5 - 6 2 x 1.5 - 4 –	1 x 10 2 x 0.75- 6 –	1 x 2.5 - 35 or 2 x 2.5 x 16 1 x 2.5 - 25 or 2 x 2.5 x 10 –
Terminals and cross-sectional area for auxiliary conductors					
• screw terminal (screw size) – with cable clamp	M 3.5				
• conductor cross-sectional area – rigid solid or rigid stranded – flexible with cable end	2 x mm <sup>2</sup> 2 x mm <sup>2</sup>	0.75 - 4 0.75 - 2.5			
Degree of protection	All the terminals are protected against direct contact according to VDE 0106/Part. 100. (without additional terminal shrouds)			All the terminals are protected against direct	
				direct contact according to VDE0106/part 100 (with additional terminal shrouds for the main terminals)	

### Pole Technical Characteristics

Types	TA25 DU	TA42 DU	TA75 DU	TA80 DU	TA10 DU	TA200 DU	TA450 DU
Number of poles	3						
Setting ranges	see page 2.6						
Tripping class according to IEC 947-4-1, EN 60947-1	10 A						
Rated operational frequencies	Hz	0 - 400					50/60
Max. switching frequency without untimely tripping	Up to 15 starts/h or 60 starts/h with 40 % on-load factor when neither the starting current of $6 \times I_n$ nor the starting time 1 s are exceeded.						
Resistance per phase in mΩ and heat dissipation in W	see page 2.13						

## Technical data TA110DU – TA450DU

2

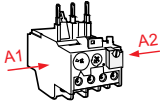
Types	TA110DU	TA200DU	TA450DU	
Standards: (international, European)	IEC 947-4-1, EN 60947-4-1			
Rated insulation voltage $U_i$ according to IEC 947-4-1	V	690	1000	
Rated impulse withstand voltage $U_{imp}$ according to IEC 947-4-1	kV	6	8	
Permissible ambient temperature – for storage – for operation	°C °C	–40 to +70 –25 to +55 with temperature compensation (maximum values: see page 2.9)		
Climatic withstand DIN 50017	Humidity in alternate climate KFW, 30 cycles			
Mounting positions	On a support at an angle of $\pm 30^\circ$ in relation to the vertical plane (standard position). Other positions possible except mounting on a horizontal plane (in this case the tripping mechanism would be located above the bimetals).			
Shock withstand at nominal $I_e$	shock duration ms	15		
Critical direction of shocks A1, A2	multiples of g	12		
Resistance to vibrations ( $\pm 1$ mm, 50 Hz)	multiples of g	8		
Mounting – on contactor – separate with DB - kit	4 x M5 screws			
Terminals and cross-sectional areas for main conductors (motor side)				
• screw terminal – with cable clamp – via tunnel connector – flat type for lug or bar		– HC, M8 –	– – M10	– – M10
• conductor cross-sectional area – rigid solid or rigid stranded		mm <sup>2</sup> 16 – 35	25 – 120	2 x 240
– flexible with cable end		mm <sup>2</sup> 16 – 35	25 – 95	2 x 240
– recommended bars		mm 12 x 3	20 x 4	20 x 4...5
Terminals and cross-sectional area for auxiliary conductors				
• screw terminal (screw size) – with cable clamp	M 3.5			
• conductor cross-sectional area – rigid solid or rigid stranded – flexible with cable end	2 x mm <sup>2</sup> 2 x mm <sup>2</sup>	0.75 - 4 0.75 - 2.5		
Degree of protection	All the terminals are protected against direct contact according to VDE 0106/Part. 100. (with additional terminal shrouds)			

### Technical characteristics of auxiliary contacts for thermal O/L relays: TA25DU to TA450DU

Auxiliary contacts		normally closed N.C.	normally open N.O.
Terminal marking		95-96	97-98
Rated operational voltage $U_e$	VAC	500	500
Conventional thermal current (in free air) $I_{th}$	A	10	6
Rated operational current $I_e$ , AC-15			
up to 240 V	A	3.0	1.5
up to 440 V	A	1.9	0.95
up to 500 V	A	1.0	0.75
Rated operational current $I_e$ , DC-13			
up to 250 V	A	0.12	0.04
Protection against short circuits			
gG (gl) fuses (according to IEC 269)	A	10	6
S 271/S 281 circuit-breaker	A	k3	k1
Maximum potential difference between N.C. and N.O. auxiliary contacts	VAC VDC	500 440	500 440

# Technical data

## Motor protection; Choice of protective device

Thermal  
Overload  
relays

2

### Motor Protection – general

It is very important to choose an adequate protective device for the safety of the motor during operation and for its durability. The efficiency of protection methods varies according to the application. The overview below will help you to choose. There is no general rule and we are available to advise you for special applications and especially in the case of difficult starting.

### Protective devices and efficiency

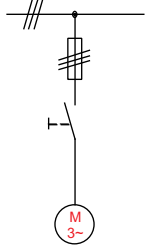
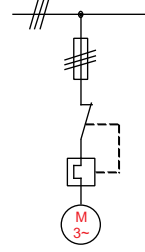
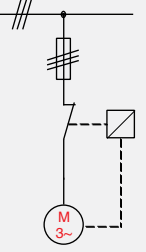
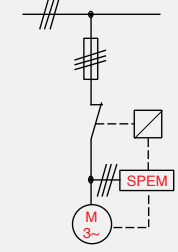
	Protection in relation to current:		Protection in relation to temperature:	
	Fuses	Protective relay with phase fault protection	Motor protection via CUSTORAPID® thermistor	Motor protection via SPEM electronic relay
				

### Causes of dangerous overloads for the motor windings

1 Overload with current 1.2 times the nominal current	<input type="checkbox"/>	<input checked="" type="checkbox"/>	<input checked="" type="checkbox"/>	<input checked="" type="checkbox"/>
2 S1-S8 nominal duties according to IEC 34-I	<input type="checkbox"/>	<input checked="" type="checkbox"/>	<input checked="" type="checkbox"/>	<input checked="" type="checkbox"/>
3 Operation with starting, braking, reversal in operating direction	<input type="checkbox"/>	<input checked="" type="checkbox"/>	<input checked="" type="checkbox"/>	<input checked="" type="checkbox"/>
4 Operation with starting rate at > 15 cycles/hour	<input type="checkbox"/>	<input checked="" type="checkbox"/>	<input checked="" type="checkbox"/>	<input checked="" type="checkbox"/>
5 Locked rotor	<input checked="" type="checkbox"/>	<input checked="" type="checkbox"/>	<input checked="" type="checkbox"/> for motors with special rotor	<input checked="" type="checkbox"/>
6 Overloads due to phase failure	<input type="checkbox"/>	<input checked="" type="checkbox"/>	<input checked="" type="checkbox"/>	<input checked="" type="checkbox"/>
7 Network undervoltage or overvoltage	<input type="checkbox"/>	<input checked="" type="checkbox"/>	<input checked="" type="checkbox"/>	<input checked="" type="checkbox"/>
8 Fluctuation of network frequency	<input type="checkbox"/>	<input checked="" type="checkbox"/>	<input checked="" type="checkbox"/>	<input type="checkbox"/>
9 Ambient temperature too high	<input type="checkbox"/>	<input checked="" type="checkbox"/>	<input checked="" type="checkbox"/>	<input type="checkbox"/>
10 Overheating due to external cause (i.e. overheating of bearings)	<input type="checkbox"/>	<input type="checkbox"/>	<input checked="" type="checkbox"/>	<input type="checkbox"/>
11 Motor cooling disturbed	<input type="checkbox"/>	<input type="checkbox"/>	<input checked="" type="checkbox"/>	<input type="checkbox"/>
12				Undercurrent protection on drop in load
13				Protection of asymmetry: wrong phase direction rotation or asymmetrical load
14				Earth fault protection
15				Automatic disconnection for auxiliary load fault

#### Protection efficiency:

- unsuitable
- very average efficiency
- perfectly efficient

#### Note: Fuses

Fuses do not protect motors against overloads. They are only used to protect installations and lines against short circuits.

To ensure efficient protection of a motor against short circuits, it is advisable to use aM type fuses in association with thermal OLR relays.

For the selection of fuses or circuit-breakers, refer to the indications given in this catalogue concerning contactors on the one hand and thermal O/L relays on the other.

In general, fuse protection for direct-on-line starting must be sized as follows:

- aM fuses: choose the fuse rating immediately above the full load value of the motor current.
- gG (gl) fuses: determine the fuse rating immediately above the motor current value and choose the next highest fuse rating.

## Technical data

### Resistance and Joule losses per phase

### Short circuit protection

2

#### Resistance and Joule losses per phase, short circuit protection

Setting range current from – to A A	Resistance per phase mΩ	Joule losses per phase at max. setting W
<b>TA25DU</b>		
0.1 – 0.16	85850	2.2
0.16 – 0.25	85150	2.2
0.25 – 0.4	13750	2.2
0.4 – 0.63	5370	2.2
0.63 – 1.0	2190	2.2
1.0 – 1.4	1120	2.2
1.3 – 1.8	670	2.2
1.7 – 2.4	383	2.2
2.2 – 3.1	229	2.2
2.8 – 4.0	137	2.2
3.5 – 5.0	87.5	2.2
4.5 – 6.5	61	2.2
6.0 – 8.5	30.4	2.2
7.5 – 11	18.2	2.2
10 – 14	11.2	2.2
13 – 19	6.3	2.3
18 – 25	4.7	2.9
24 – 32	3.2	3.3
<b>TA42DU</b>		
18 – 25	5.5	3.43
22 – 32	2.89	2.91
29 – 42	1.84	3.24
<b>TA75DU</b>		
18 – 25	5.5	3.43
22 – 32	2.89	2.91
29 – 42	1.84	3.24
36 – 52	1.3	3.51
45 – 63	0.936	3.72
60 – 80	0.615	3.94
<b>TA80DU</b>		
29 – 42	1.84	3.24
36 – 52	1.3	3.51
45 – 63	0.936	3.72
60 – 80	0.615	3.94

Setting range current from – to A A	Resistance per phase mΩ	Joule losses per phase at max. setting W
<b>TA110DU</b>		
80 – 110	0.378	3.78
<b>TA200DU</b>		
100 – 135	0.318	5.79
110 – 150	0.255	5.74
130 – 175	0.214	6.55
150 – 200	0.182	7.28
<b>TA450DU</b>		
130 – 185	—	2.5
165 – 235	—	2.5
220 – 310	—	2.5

# Technical data

## Tripping curves

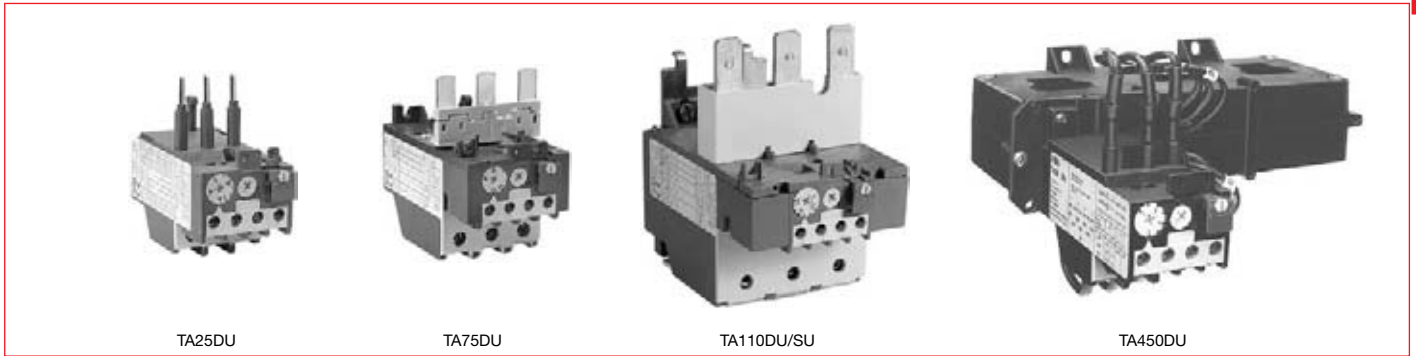

TA-DU thermal O/L relays are 3-pole with manual or automatic resetting mode selection.

The resetting button can also be used for stopping.

Built-in auxiliary contacts are physically separate and, consequently, can be used in different circuits (control circuit/indication circuit).

Each relay is temperature compensated and ensures phase failure protection.

Protective relays up to size TA75DU are protected against direct contact via the front face. Terminal shrouds are available for TA200DU to TA450DU size relays.

The connecting terminals are delivered in open position with (+,-) pozidriv screws and screwdriver guidance. It is advisable to tighten unused terminal screws.

### Thermal O/L relay tripping curves

**TA25DU**  
(tripping class 10A)

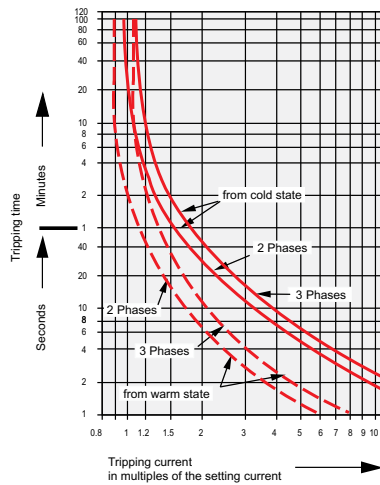

**TA42DU, TA75DU and TA80DU**  
(tripping class 10A)

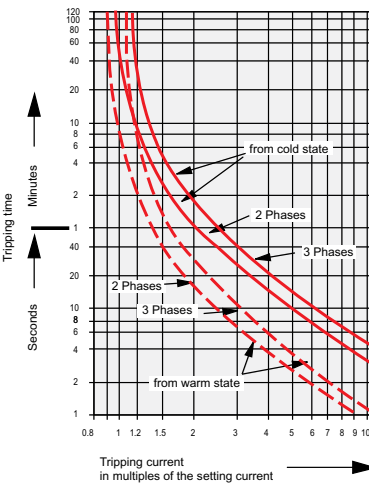

**TA110DU**  
(tripping class 10A)

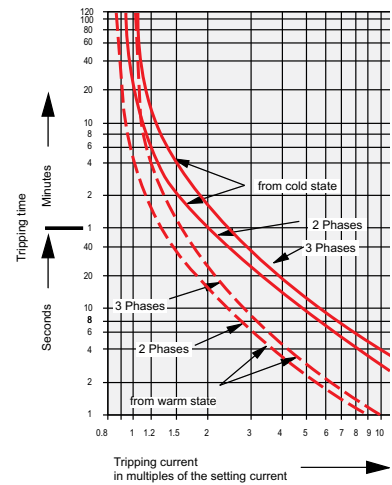

**TA200DU**  
(tripping class 10A)

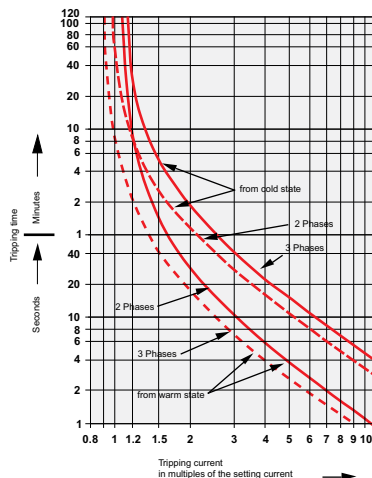

**TA450DU**  
(tripping class 10A)

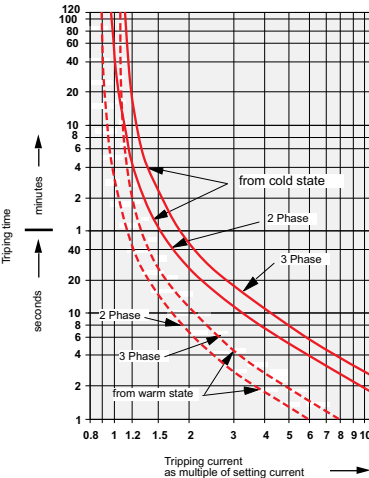

## Technical data, Class 20 OLR

### Resistance and Joule losses per phase

### Short circuit protection

Setting Range from ... to A A	Short-circuit protection (fuses)		UL	UL	Resistance per phase mOhm	Power Loss per phase at upper current setting W
	Type "2" co-ordination gL/gG A	Type "1" co-ordination gL/gG A	Fuse/600V K5 A	600V CB A		
<b>Thermal overload relay TA25DU trip class 20</b>						
1.3 ... 1.8	10	25	6	-	670.3	2.2
1.7 ... 2.4	16	25	10	-	381	2.2
2.2 ... 3.1	16	25	10	-	235.3	2.3
2.8 ... 4.0	20	25	15	-	140.7	2.3
3.5 ... 5.0	25	25	20	-	91.2	2.3
4.5 ... 6.5	25	25	25	-	54.5	2.3
6.0 ... 8.5	32	32	35	-	32.1	2.3
7.5 ... 11	40	40	45	-	15.5	1.9
10 ... 14	50	50	60	-	12	2.4
13 ... 19	63	63	60	-	6.3	2.3
18 ... 25	80	80	70	-	4.7	3.0
24 ... 32	100	100	100	-	3.2	3.3
<b>Thermal overload relay TA42DU trip class 20</b>						
18 ... 25	100	160	80	80	5.5	3.43
22 ... 32	125	160	100	80	2.89	2.91
29 ... 42	160	160	150	80	1.84	3.24
<b>Thermal overload relay TA75DU trip class 20</b>						
18 ... 25	100	160	80	80	5.5	3.43
22 ... 32	125	160	100	80	2.89	2.91
29 ... 42	160	160	150	80	1.84	3.24
36 ... 52	200	200	175	125	1.3	3.51
45 ... 63	200	250	200	125	0.936	3.72
60 ... 80	250	250	250	125	0.615	3.94
<b>Thermal overload relay TA80DU trip class 20</b>						
29 ... 42	160	160	150	80	1.84	3.24
36 ... 52	200	200	175	125	1.3	3.51
45 ... 63	200	250	200	125	0.936	3.72
60 ... 80	250	250	250	150	0.615	3.94

Type 1 co-ordination according to IEC 60947-4-1: Under short-circuit conditions, the starter shall cause no danger to persons or installation and may not be suitable for further service without repair and replacement of parts.

Type 2 co-ordination according to IEC 60947-4-1: Under short-circuit conditions, the contactor or starter shall cause no danger to persons or installation and shall be suitable for further use. The risk of contact welding is recognized, in which case the manufacturer shall indicate the measures to be taken as regards the maintenance of the equipment.

**Standard technical data, operating data and dimensions see TA...Relay Main Catalog**



# Technical data, Class 20 OLR

## Short-circuit ratings

Thermal  
Overload  
relays

2

Setting Range A ... A	Catalog number	Voltage 480V	5 kA		10 kA		18 kA	
			Fuse K5	CB	Fuse K5	CB	Fuse K5	CB
1.3 ... 1.8	TA25DU-1.8-20	TA25DU	6	-	6	-	6	-
1.7 ... 2.4	TA25DU-2.4-20		10	-	10	-	10	-
2.2 ... 3.1	TA25DU-3.1-20		10	-	10	-	10	-
2.8 ... 4.0	TA25DU-4.0-20		15	-	15	-	15	-
3.5 ... 5.0	TA25DU-5.0-20		20	-	20	-	20	-
4.5 ... 6.5	TA25DU-6.5-20		25	-	25	-	25	-
6.0 ... 8.5	TA25DU-8.5-20		35	-	35	-	35	-
7.5 ... 11	TA25DU-11-20		45	-	45	-	45	-
10 ... 14	TA25DU-14-20		60	-	60	-	60	-
13 ... 19	TA25DU-19-20		60	-	60	-	60	-
18 ... 25	TA25DU-25-20		70	-	70	-	70	-
24 ... 32	TA25DU-32-20		100	-	100	-	100	-
18 ... 25	TA42DU-25-20	TA42DU	80	80	80	-	150	-
22 ... 32	TA42DU-32-20		100	80	100	-	150	-
29 ... 42	TA42DU-42-20		150	80	150	-	200	-
18 ... 25	TA75DU-25-20	TA75DU	80	80	80	-	150	-
22 ... 32	TA75DU-32-20		100	80	100	-	150	-
29 ... 42	TA75DU-42-20		150	80	150	-	200	-
36 ... 52	TA75DU-52-20		175	125	175	-	250	-
45 ... 63	TA75DU-63-20		200	125	200	-	250	-
60 ... 80	TA75DU-80-20		250	125	250	-	250	-
29 ... 42	TA80DU-42-20	TA80DU	150	80	150	-	150	-
36 ... 52	TA80DU-52-20		175	125	175	-	175	-
45 ... 63	TA80DU-63-20		200	125	200	-	250	-
60 ... 80	TA80DU-80-20		250	150	250	-	250	-

Setting Range A ... A	Catalog number	Voltage 600V	5 kA		10 kA		18 kA	
			Fuse K5	CB	Fuse K5	CB	Fuse K5	CB
1.3 ... 1.8	TA25DU-1.8-20	TA25DU	6	-	6	-	6	-
1.7 ... 2.4	TA25DU-2.4-20		10	-	10	-	10	-
2.2 ... 3.1	TA25DU-3.1-20		10	-	10	-	10	-
2.8 ... 4.0	TA25DU-4.0-20		15	-	15	-	15	-
3.5 ... 5.0	TA25DU-5.0-20		20	-	20	-	20	-
4.5 ... 6.5	TA25DU-6.5-20		25	-	25	-	25	-
6.0 ... 8.5	TA25DU-8.5-20		35	-	35	-	35	-
7.5 ... 11	TA25DU-11-20		45	-	45	-	45	-
10 ... 14	TA25DU-14-20		60	-	60	-	60	-
13 ... 19	TA25DU-19-20		60	-	60	-	60	-
18 ... 25	TA25DU-25-20		70	-	70	-	70	-
24 ... 32	TA25DU-32-20		100	-	100	-	100	-
18 ... 25	TA42DU-25-20	TA42DU	80	80	80	-	150	-
22 ... 32	TA42DU-32-20		100	80	100	-	150	-
29 ... 42	TA42DU-42-20		150	80	150	-	200	-
18 ... 25	TA75DU-25-20	TA75DU	80	80	80	-	150	-
22 ... 32	TA75DU-32-20		100	80	100	-	150	-
29 ... 42	TA75DU-42-20		150	80	150	-	150	-
36 ... 52	TA75DU-52-20		175	125	175	-	175	-
45 ... 63	TA75DU-63-20		200	125	200	-	250	-
60 ... 80	TA75DU-80-20		250	125	250	-	250	-
29 ... 42	TA80DU-42-20	TA80DU	150	80	150	-	150	-
36 ... 52	TA80DU-52-20		175	125	175	-	175	-
45 ... 63	TA80DU-63-20		200	125	200	-	250	-
60 ... 80	TA80DU-80-20		250	150	250	-	250	-

## Technical data, Class 20 OLR Table for tripping time

2

Tripping times of thermal overload relays as a function of a multiple of the setting current from cold state (tolerance +/- 20% of the tripping time).

Setting Range from ... to A A	Tripping times of thermal overload relays: at multiple of setting current					
	3	4	5	6	7.2	8

Tripping times in seconds

### Thermal overload relays TA25DU trip class 20

1.3 ... 1.8	47.1	27	20.3	15.8	12.7	11.5
1.7 ... 2.4	43.3	25	18.9	14.4	11.9	10.4
2.2 ... 3.1	47.5	28	20.8	16	13.1	11.8
2.8 ... 4.0	45.6	27	19.8	15.3	12.5	11
3.5 ... 5.0	47.8	29	21.2	16	13.2	11.8
4.5 ... 6.5	47.4	28	20.3	15.5	12.5	11
6.0 ... 8.5	46.1	27	20	15	11.7	10
7.5 ... 11	42.3	25	17.8	14.1	10.9	10.5
10 ... 14	39.4	25	16.8	13	9.9	8.5
13 ... 19	38.1	21	13.6	10	7.4	6.2
18 ... 25	44.4	25	16.1	11	9	8
24 ... 32	44.4	27	17.7	13	9.8	8.5

### Thermal overload relays TA42DU, TA75DU, TA80DU trip class 20

18 ... 25	51.6	29	20.3	15	11.7	10
22 ... 32	67.9	38	26.9	20	14.8	12.5
29 ... 42	58.8	33	22.5	16	12.2	10.3
36 ... 52	59.9	34	22.7	16	12.3	10.5
45 ... 63	65.8	34	22.4	16	12.4	10.5
60 ... 80	71.9	35	23.4	17	13.9	12

# Approximate dimensions T25DU – TA42DU

00.00 Inches  
00.00 [Millimeters]

## TA25DU

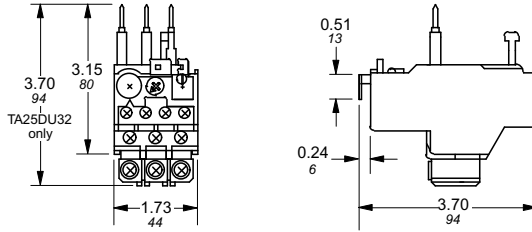

## TA25DU & DB25

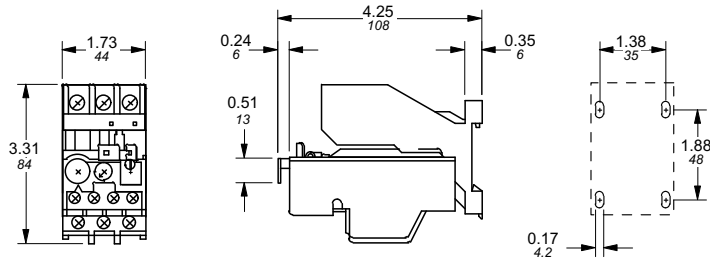

## TA25DU & DB25/32

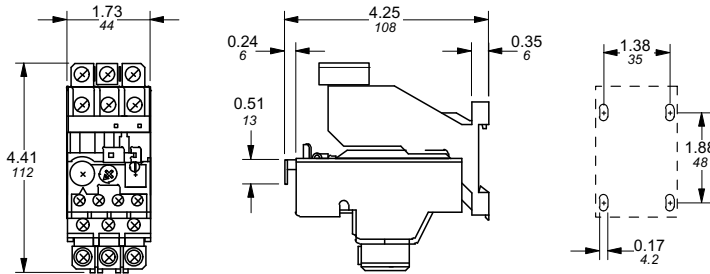

## TA42DU

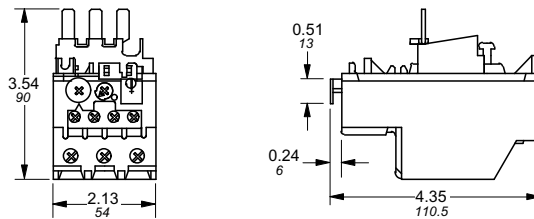

## TA42DU / TA75DU & DB80

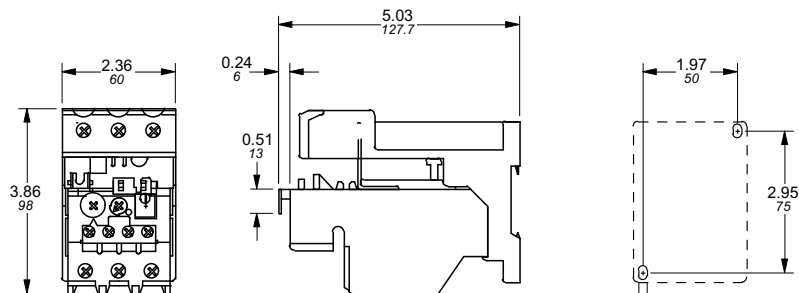

# Approximate dimensions TA75DU – TA200DU

00.00 Inches  
00.00 [Millimeters]

2

## TA75DU

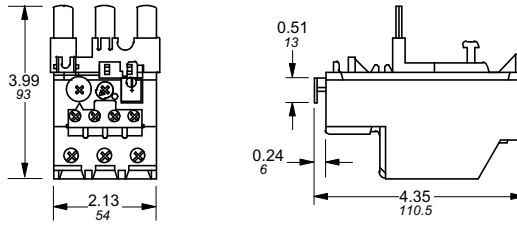

## TA80DU

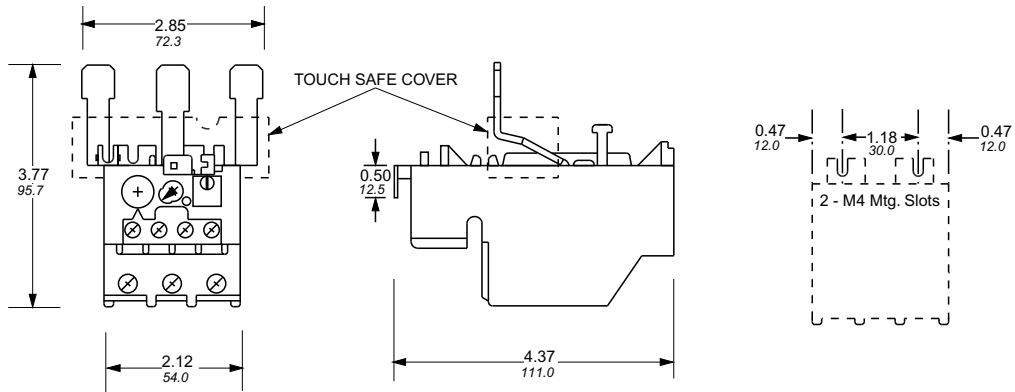

## TA110DU

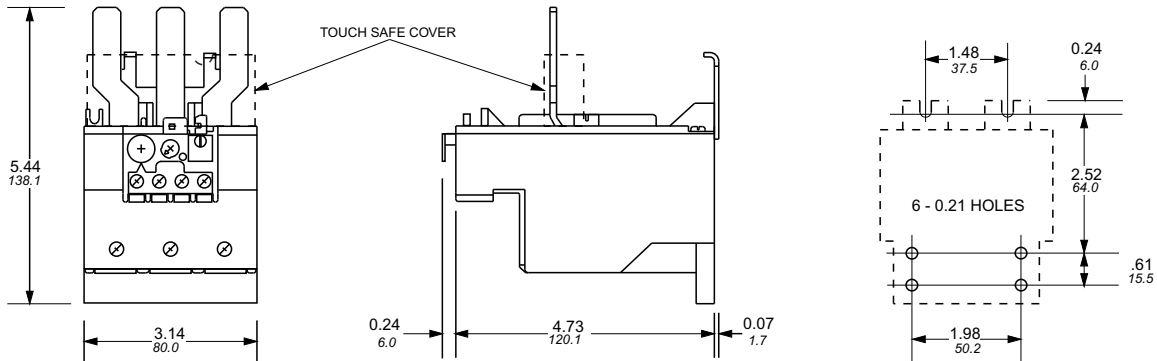

## TA200DU

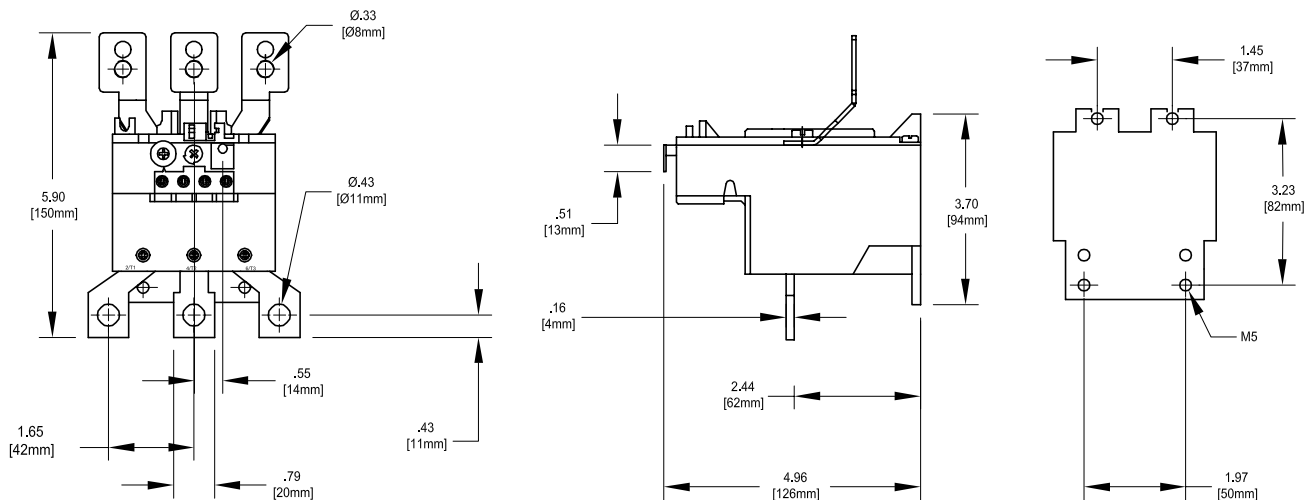

# Approximate dimensions TA450DU

Thermal  
Overload  
relays

00.00 Inches  
00.00 [Millimeters]

2

## TA450DU

