

# Control Cabinet

## No Arc Welding Equipment

503 636-102  
2001-05-17

S4Cplus

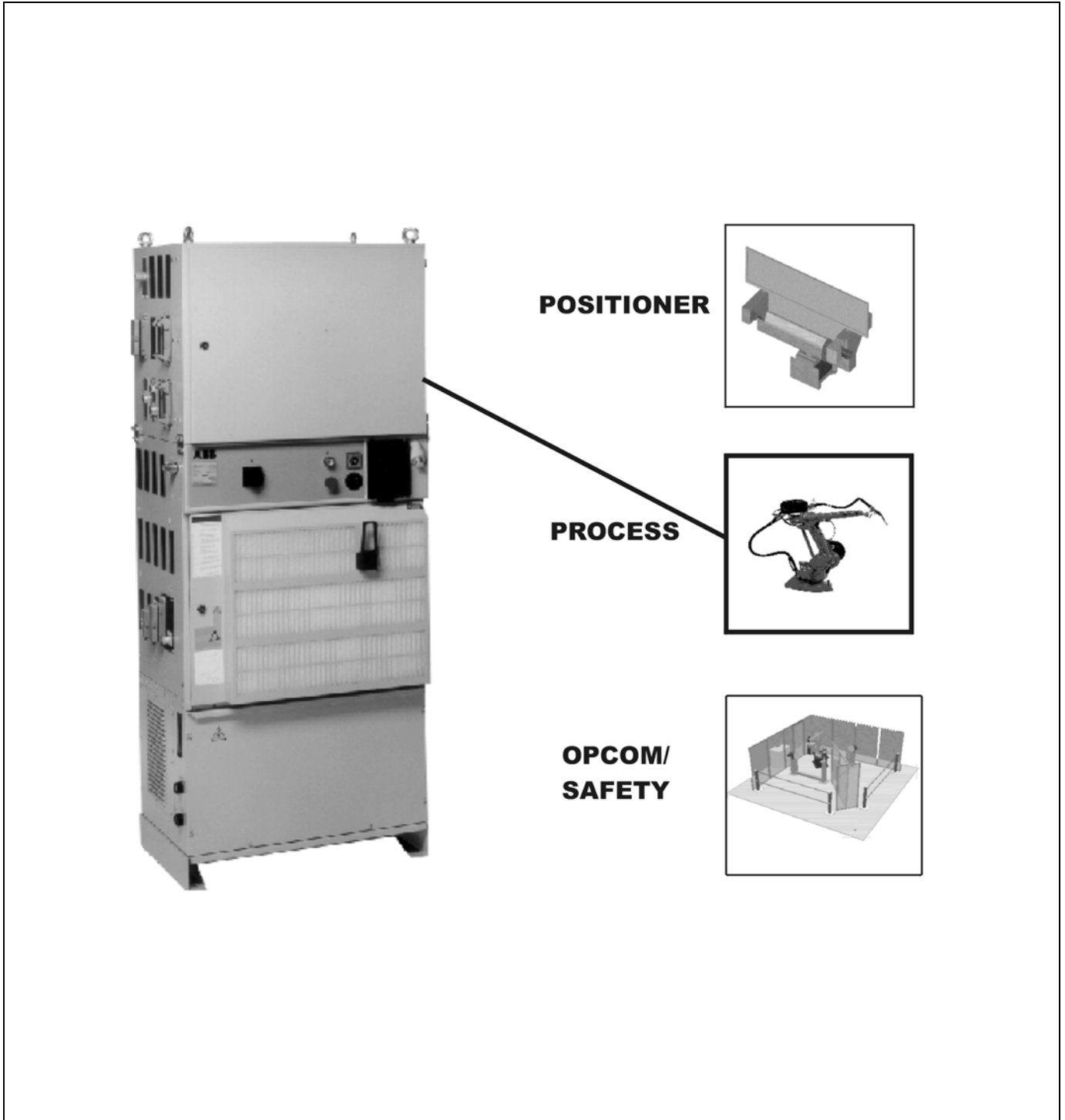

**ABB Flexible Automation AB**  
**Welding Systems**



The information in this document is subject to alteration without prior notice and should not be regarded as an undertaking from ABB Flexible Automation AB. ABB Flexible Automation AB takes no responsibility for errors that can occur in this document.

ABB Flexible Automation AB is not responsible for damage incurred due to the misuse of this document, software or hardware described in this document.

The document, or parts of it, may not be reproduced or copied without prior permission from ABB Flexible Automation AB. It may neither be imparted to a third party nor otherwise be used without authorisation. Infringement hereof will be subject to action in accordance with applicable laws.

Further copies of this document can be obtained from ABB Flexible Automation AB at current prices.

© ABB Flexible Automation AB

Article number: 503 636-102

Date: 2001-05-17

ABB Flexible Automation AB

Welding Systems

S-695 82 Laxå

Sweden.

## TABLE OF CONTENTS

		Page
<b>1</b>	<b>Process equipment</b> .....	<b>5</b>
1.1	General.....	5
1.2	System design.....	5
1.3	Connection.....	7
1.3.1	Strapping unit NO AW.....	9
<b>2</b>	<b>Reservdelsförteckning/<i>Spare Parts List</i></b> .....	<b>11</b>



---

---

# 1 Process equipment

---

## 1.1 General

### Software

Connection of process equipment for arc welding requires a control cabinet ordered with one of the software options 551/552, ARCWARE/ARCWAREplus.

### Welding equipment

For robots IRB140/1400/2400 there is fully prepared welding equipment available adapted for connection to the system:

Some welding equipment with the wire-feed unit mounted on the robot's upper arm utilise the internal cable harness in the robot for connection of signals. In these cases the robot must be ordered with option 042 "Integrated wire-feed unit cables".

### Accessories

The system is prepared for the easy connection of different accessories to the process equipment such as:

Mechanical gun cleaner

Calibration equipment

Joint location equipment

Joint tracking equipment

---

## 1.2 System design

### Free-standing welding power supply

There is a process control card for communication with the robot's control system for control and supervision of the welding power source, wire-feed system and connected accessories. This is mounted on a module together with other components for control of the process equipment in the control cabinet.

A process control card with integrated motor regulator is used for welding equipment from the standard range.

Communication between the process control card and the control system takes place via a CAN-bus.

This system also makes it possible to control some welding power sources from other OEM-brands.

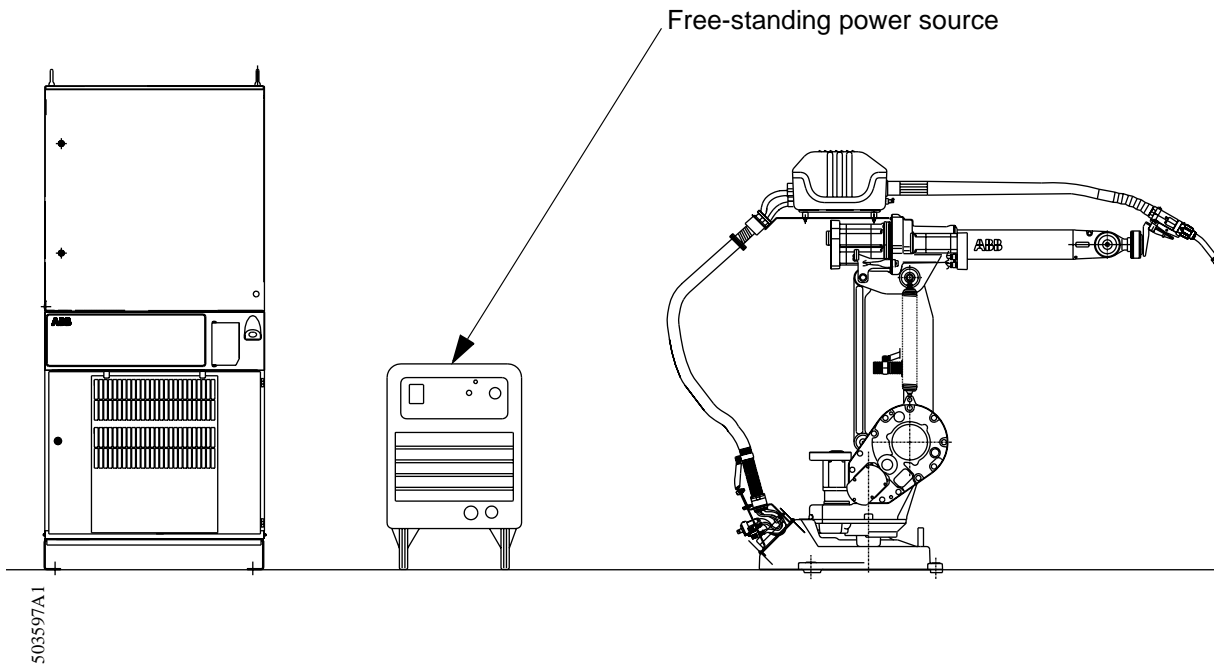

Connection of an OEM-welding power source demands full conversance with the operation of the power source, how signal exchange should be managed and how the welding power source in question should be configured in the control system.

### **Welding power source integrated with the control cabinet**

Communication with the control system takes place directly via the CAN-bus for this type of welding power source. The welding power source is available in two designs, integrated with the control cabinet or free-standing.

A process control card is used for communication with the robot's control system for control and supervision of the wire-feed system and connected accessories.

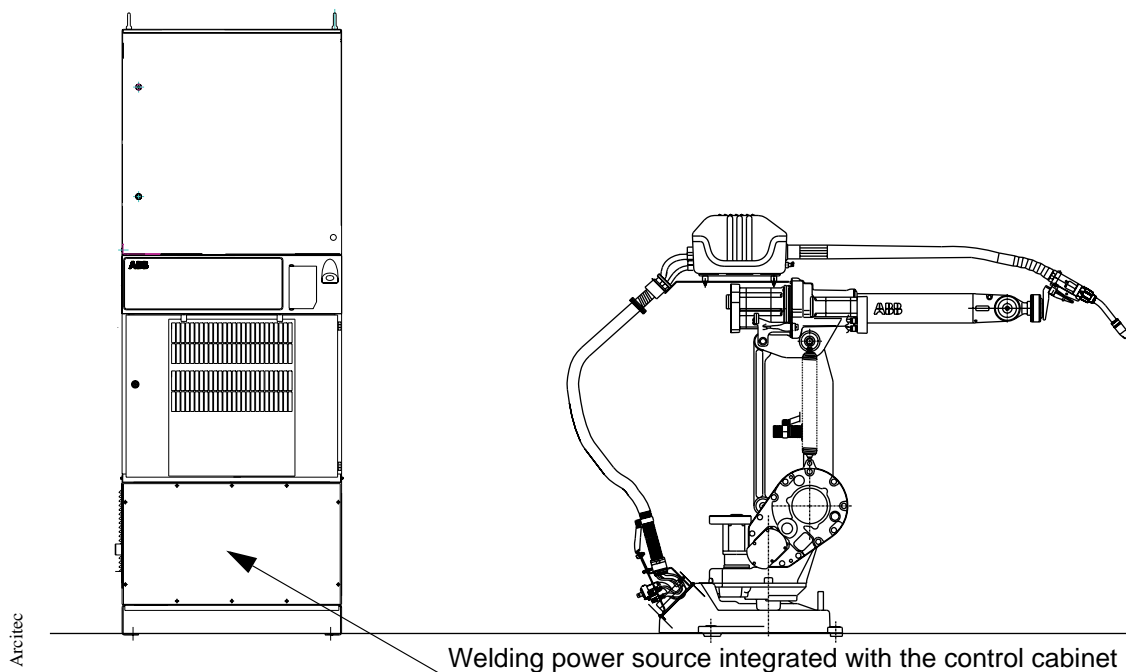

---

### **1.3 Connection**

The cable harness to external equipment is connected to the output on the left-hand side of the cabinet or to jackable terminals mounted internal by the separable cable gland.

**Process equipment**

Ultrag2

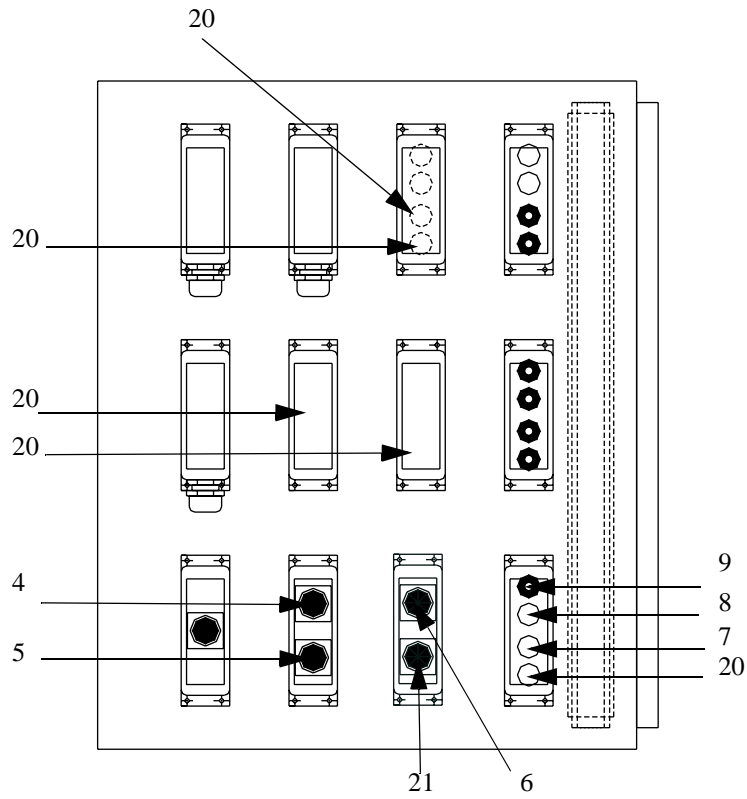

- |                            |                                  |
|----------------------------|----------------------------------|
| 4. Wire feed unit motor    | 8. TCP-tool / Water cooling unit |
| 5. Wire feed unit signal   | 9. Mechanical cleaner            |
| 6. Power source            | 20. Spare / Power source LRC     |
| 7. Wire feed unit ALU 40kg | 21. Wire feed unit ALU 40kg      |



### 1.3.1 Strapping unit NO AW

The welding equipment's interface is replaced by an assembly plate on installations without welding equipment. This includes requisite strapping, etc. for internal wiring inside the cabinet.

The assembly plate is fitted on inside of the cabinet's right-hand side panel and can be used as extra space for other customer specific equipment.

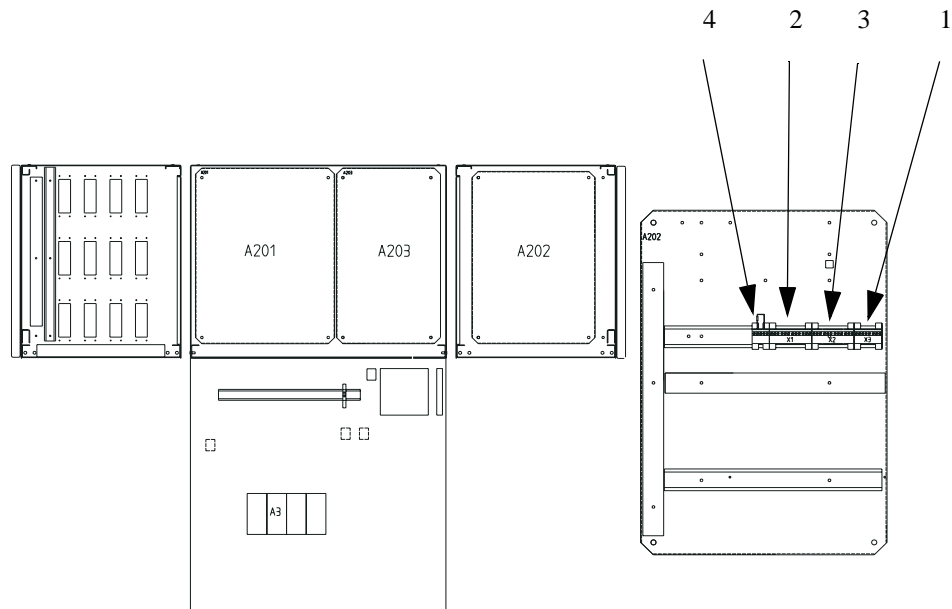

503270

1. Power supply. A202-X3
2. Strapping unit emergency stop. A202-X3
3. Strapping unit run chain. A202-X3
4. Termination CAN-bus. A202-X3

#### Power supply

The following voltages are available on the jackable terminal A202-X3:

- 24V DC (24V I/O)
- 115V AC
- 230V AC

#### Control

#### Interlocks

The following run chain signals are available on the jackable terminal A202-X2:

- Auto stop
- General stop

- External motors on
- External motors on contactor control

The following emergency stop signals are available on the jackable terminal A202-X1:

- External push button
- Emergency stop out
- External limit switches

### **CAN-bus**

The terminated CAN-bus channel A202-TB2 can be used, e.g. for the connection of an extra I/O card.

---

---

## **2 Reservdelsförteckning/Spare Parts List**

Reservdelar beställs genom ABB Flexible Automation AB. Vid beställning var vänlig uppge typ och tillverkningsnummer samt benämningar och beställningsnummer enligt reservdelsförteckningen.

Rätt till ändring av specifikationer utan avisering förbehålles.

*Spare parts are to be ordered from ABB Flexible Automation AB. Kindly indicate type of unit, serial number, denominations and ordering number according to the spare parts list.*

*Rights to reserved to alter specifications without notice.*

**Reservdelsförteckning/Spare Parts List**

<b>Positions- nummer Position number</b>	<b>Antal Quantity</b>	<b>Beställningsnummer Ordering number</b>	<b>Benämning</b>	<b>Denomination</b>	<b>Anmärkingar Remarks</b>
		503 270-880	<b>Proc.utr. NO PROC IF</b>	<b>Proc.dev. NO PROC IF</b>	
1		489 947-451	Combicon 12pol 1-12 stift	Combicon 12p 1-12 pin	
2		489 947-447	Combicon 8pol M.1-8 stift	Combicon 8p M.1-8 pin	
3		502 796-881	CANBUS-terminering hona	CAN-bus termination female	
4		193 817-003	Ändhylsa 1.0 (mm2)	End sleeve 1.0 (mm2)	
5		418 883-006	Kabelkanal BE	Cable trunking BE	
6		489 327-025	Skruv MRT-TT M5X8	Screw MRT-TT M5X8	
7		212 601-109	Mutter 6K stål 8.8 M8	Nut 6K steel 8.8 M8	
8		219 501-311	Bricka lås AZ	Washer AZ	
9		502 940-087	Enledarkabel AWG 18 BU	Single core AWG 18 BU	

**Reservdelsförteckning/Spare Parts List**

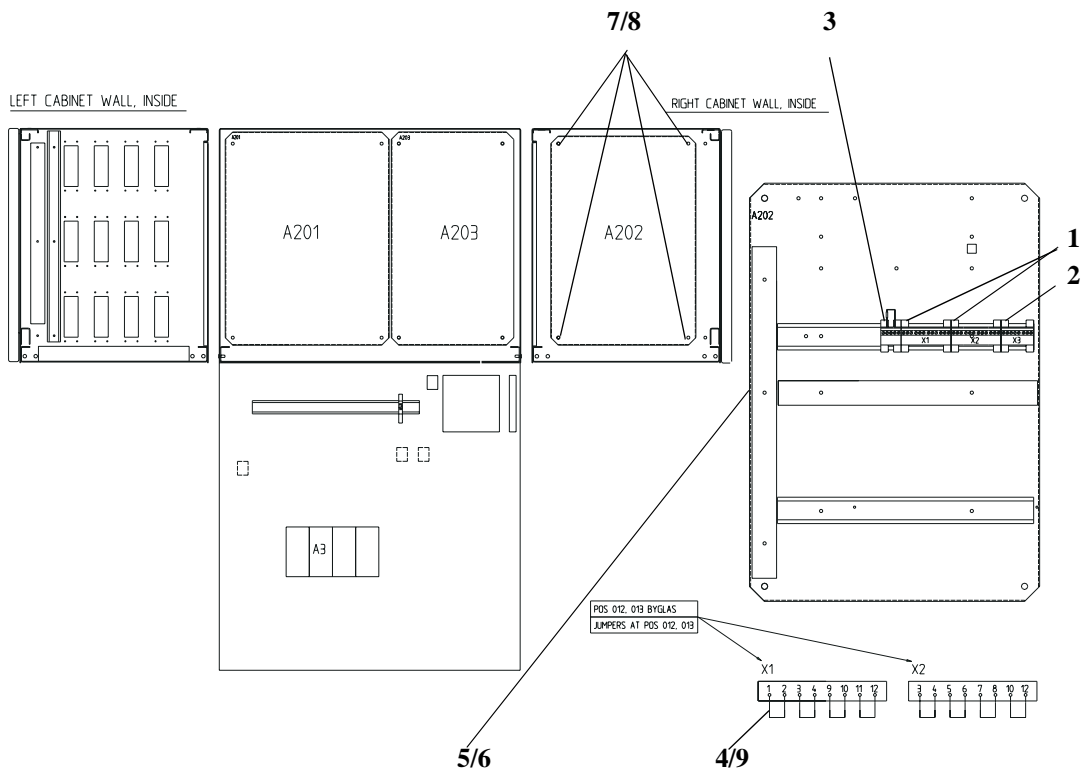

503270A01





