

---

COMPANY PROFILE

# Ingenious manufacturing and intelligence lead the future

Introduction to ABB Xiamen Switchgear Co., Ltd.

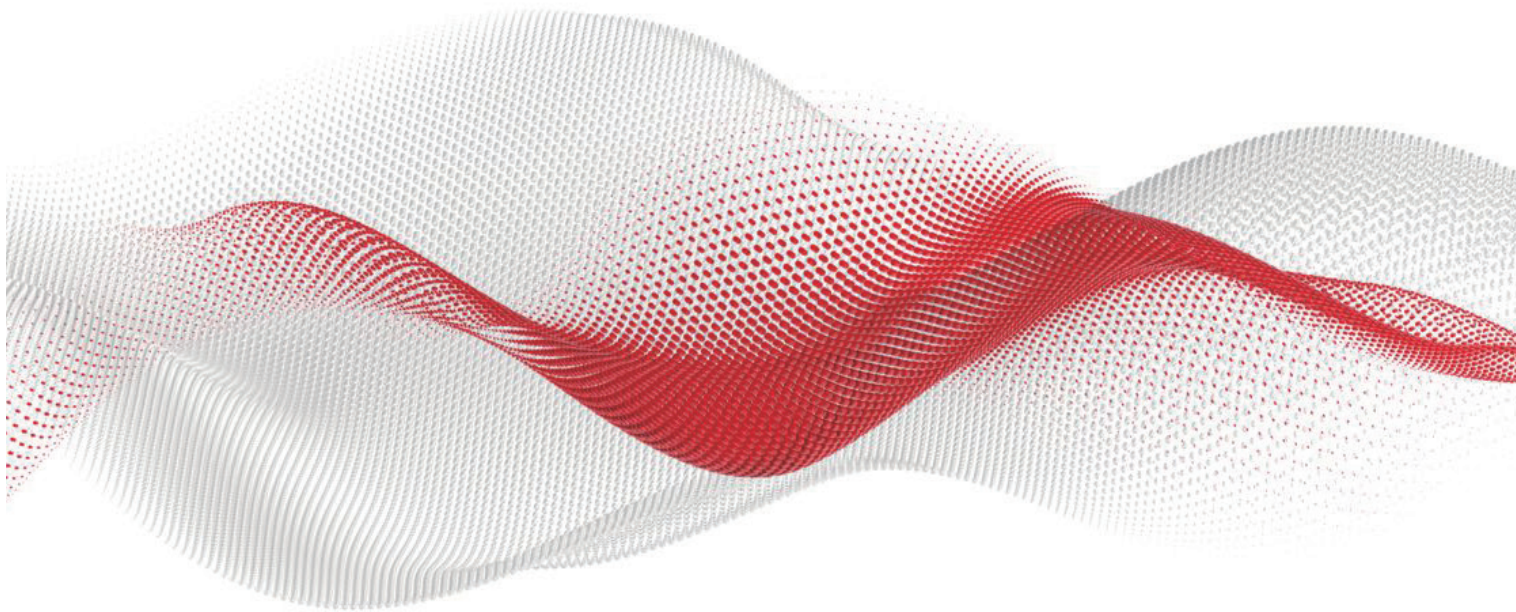

- Digital switchgear
- All-series indoor and outdoor components
- Life cycle management of equipment



---

# Table of contents

<b>1. ABB in China</b>	04
<b>2. ABB Xiamen Switchgear Co., Ltd.</b>	06
<b>3. Switchgear profit center</b>	10
<b>4. Component division</b>	29
<b>5. Power distribution system services of ABB China</b>	45

# ABB in China

ABB is a leading global technology company that energizes the transformation of society and industry to achieve a more productive, sustainable future. By connecting software to its electrification, robotics, automation and motion portfolio, ABB pushes the boundaries of technology to drive performance to new levels.

ABB was formed in 1988, when the Swedish Asea and the Swiss BBC Brown Boveri merged under the name of ABB, headquartered in Zurich, Switzerland. With a history of excellence stretching back more than 130 years, ABB's success is driven by about 105,000 talented employees in over 100 countries.

ABB's relationship with China dates back to 1907, when it delivered a steam boiler to the country. After decades of fast development, ABB today has a full range of business activities in China, including R&D, manufacturing, sales and services, 27 local companies with 15,000 employees located in nearly 130 cities and online and offline channels across around 700 cities. ABB has invested US\$2.4 billion in China since 1992. China is ABB's second-largest market worldwide with more than 90% of sales from locally-made products, solutions and services.

## **Driving the digital transformation of industries**

As a pioneering leader in digitalization for more than 40 years, ABB combines its deep domain expertise with connectivity and software innovation to empower real-time, data-driven decisions for safer, smarter operations that maximize resource efficiency and contribute to a low-carbon future. The company employs some 7,000 researchers globally, of which more than 60 percent are focused on software development and digitalization.

Since ABB Ability™ was launched in China market in 2017, ABB has delivered customized digital solutions for local customers of many industries. ABB is also collaborating with world's top companies

and institutions to innovate and develop leading Industrial Internet solutions. In 2020, the release of ABB Ability™ platform on Huawei cloud has further intensified ABB's efforts to support China's industrial digitalization. With its technology and business highly aligned with the focuses of China's "new infrastructure", ABB is making strategic presence in such key areas as digitalization, industrial Internet, artificial intelligence, smart manufacturing, smart transportation and smart energy infrastructure, and working proactively with customers and partners to support China's industry upgrading and digital transformation.

## **In China, for China and the World**

ABB has been at the forefront of every industrial revolution with its leading technologies throughout the history, promoting the evolution and development of industries. In China, ABB regards innovation as a key to keep its long-term competitive edge and has continuously improved its local R&D capabilities. In recent years, the China R&D teams have led or participated in the research and development of smart sensors, dual-arm robot YuMi®, i-Jia smart home system, Terra 63Z DC fast charger and HDS water-cooled AC synchronous permanent magnet servo motor, ABB Ability™ NB-IoT solution for measurement device and so on. In 2020, the local R&D team filed 11% more PCT and invention patents than in the previous year.

Following the long-term commitment of "In China, for China and the World", ABB has continuously invested in China, further optimizing its business footprint, and driving the localization of the whole value chain, with such recent examples as the inauguration of ABB Xiamen Hub Xiamen, the acquisition of Chargedot Shanghai New Energy Technology Co. Ltd. and the building of new robotics factory with investment of RMB 1 billion which will be ABB's most advanced, automated and flexible factory worldwide. With a business network covering more than 100 countries around the world, industry-leading technologies and rich

project management experience, ABB has actively supported Chinese enterprises to explore business opportunities from Belt and Road initiative and enhance competitiveness around the world.

#### **Energizing the transformation of society for a sustainable future**

Sustainability is a key part of ABB Purpose. ABB embeds sustainability in everything they do to promote sustainable development. With 2030 sustainability strategy, ABB partners with the customers and suppliers to enable a low-carbon society, preserve resources and promote social progress. ABB aims to be carbon-neutral by 2030 and support customers in reducing their annual CO2 emissions by at least 100 megatonnes when 80% of ABB products & solutions will be covered by circularity approach. Taking the e-mobility for example, ABB has sold more than 400,000 EV chargers in 85 countries to support global sustainable transport.

With a clear commitment to society, ABB actively supports China's plan to become carbon neutral before 2060 by deploying highly efficient solutions in its facilities and helping customers improve energy efficiency, lower environment impact and achieve long-term sustainable development. Meanwhile, ABB Group executives have been members of mayor's or governor's advisors in Beijing, Shanghai, Chongqing and Guangdong, proposing forward-looking advices to support China's sustainable growth. ABB has participated in such charity activities as caring for senior citizens, planting trees, volunteering in communities, and hosting electrical safety seminars. In the field of education, ABB has donated about RMB 16 million accumulatively via ABB-New Great Wall Fund, benefiting nearly 5,000 students from 46 universities and colleges. ABB is also strengthening cooperation with universities and supporting talent cultivation by hosting the annual ABB Cup Innovation Contest.

#### **Milestones in China**

- 1974 Set up first China office in Hong Kong
- 1979 Set up permanent office in Beijing
- 1992 Established first manufacturing joint venture in China
- 1994 Moved ABB China's headquarters to Beijing
- 1995 Established holding company – ABB (China) Ltd.
- 2004 Won major Three Gorges orders
- 2005 Set up global research centers in Beijing & Shanghai
- 2006 Moved global Robotics center to China
- 2008 Contributed to over 30 Beijing Olympics projects
- 2009 Launched the first locally developed robot – IRB 120
- 2010 Started e-commerce business in China
- 2011 Set up global marine propulsion system base in Shanghai
- 2012 Launched ABB University Innovation Contest
- 2014 Announced investment of RMB2 billion to set up an industrial hub in Xiamen
- 2017 Launched industry-leading digital solutions offering ABB Ability™ in China
- 2018 Announced the plan to build its most advanced robotics factory in Shanghai
- 2019 ABB Formula E Championship held in Hong Kong & Sanya
- 2020 Completed the acquisition of Chargedot Shanghai New Energy Technology Co., Ltd.

# ABB Xiamen Switchgear Co., Ltd.

A leader in technology -- ABB Xiamen Switchgear Co., Ltd. established in 1992, ABB Xiamen Switchgear Co., Ltd. is the first ABB joint venture in China. The company specializes in the production, sales and service of 3.6 kV - 40.5 kV circuit breakers and medium voltage switchgears. The Company has high-quality staff and 70% of them are highly educated. The company adopts multiple sales models including direct sales, distribution,

channel sales, OEM sales and project partners, etc. The company has become a leading manufacturer of medium-voltage switchgears and circuit breakers, and has established a service center taking "life-cycle management" as its core and covering the national network, to provide customers with all the services from product commissioning, operation management to decommissioning.

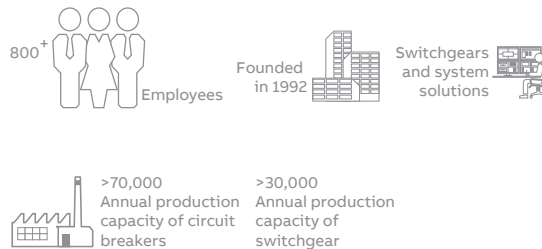

## An industry pioneer and technology leader

- The first company in China designing, producing and selling 12 kV intermediate switchgears, environment friendly pole-type modularized vacuum circuit breakers and smart switchgears
- ISO 9001 certificate was obtained in 1994
- ISO 14001 certificate was obtained in 1996
- It won the title of "UN Clean Production Enterprise" in 1998
- It won the "National Quality Management Award" in 2002
- In 2004, it was awarded the title of "Trustworthy Enterprise" issued by the State Administration for Industry and Commerce
- In 2012, it won the "Quality Management Award" issued by China Nuclear Power Engineering Co., Ltd.
- In 2013, it won the "National Model Enterprise for Safety Culture Building" issued by the State Administration of Work Safety
- In 2014, it obtained the certificate of conformity of "Five-star After-sales Service Evaluation" issued by China Quality Certification Center CQC
- In 2016, with the practical experience of cloud services, ABB Medium-voltage Remote Center was successfully selected into the 2016 National Quality Benchmark List announced by the Ministry of Industry and Information Technology

- In 2017, it obtained the design license and manufacturing license of equipment for civil nuclear safety issued by the National Nuclear Safety Administration
- In 2018, it won the "5A Excellent Supplier" issued by China Nuclear Power Engineering Co., Ltd.
- In 2019, it obtained the certificate of Integrated Management System of Industrialization and Informationization
- In 2019, it won the "Outstanding Organization of the 40th Anniversary for Promoting Total Quality Management" issued by China Quality Association
- The company has been listed in "Top 100 Companies in Electrical Industry" for successive years

## Fulfill corporate civic responsibility

- Adopt most advanced technology, reducing thousands of tons of CO<sub>2</sub> emissions each year
- Make contributions for local social & economic development and employment
- Establish scholarship in Xiamen City Education Fund Association
- Establish ABB Scholarship and carry out school-enterprise cooperation in Xiamen University of Technology
- Establish ABB Scholarship in Xiamen Technician College

**Ingenious manufacturing and intelligence lead the future**

Quality forges the excellence and innovation leads the future. As the ABB's largest production base for medium-voltage switchgear and circuit breakers in the world, the company has focused on product quality while actively developing innovative and intelligent products. In 2011, it was the first to launch iUniGear intelligent solution, which opened the era of intelligent switchgear. It launched the environmentally friendly switchgear ZX0 Air and ZX2 Airplus respectively in 2016 and 2017. In 2019, the company continued to lead innovation and launched UniGear ZS1 with 500 mm width and ConVac vacuum contactors. Innovation never stops. The company will always devote to product innovation and development to create greater value for customers and partners in all industries.

**Practice in China, for China and the world**

- As a technology leader in the industry, we foster and support local partners and lead the development of the industry
- Our products and services extend over all industries. And we've delivered nearly 400,000 sets of switchgears and 900,000 sets of circuit breakers
- Our overseas business spreads over 6 continents and over 70 countries

# Customer-oriented and total quality management throughout the whole value chain

Implement the “Quality Win” strategy to create excellent quality. ABB Xiamen Switchgear Co., Ltd., as the first manufacturing base of ABB Group in China, has adhered to the management philosophy of “customer and quality first”, actively implemented ABB’s quality policy, delivered quality goods on time, identified and understood customer expectations, promoted the participation of all employees, improved employee morale and skills, leveraged the advantages of partners and suppliers, assumed social responsibility and business ethics, and continuously improved environment, health and safety performance. By actively listening to the voices of customers, the company has assessed the operation objectives to meet customer requirements, identified the gap and closed it by using Lean Six Sigma and continuous improvement. The company has continuously improved products, service quality and management level to ensure that our responsibilities and obligations to customers, employees, partners, suppliers and shareholders can be fulfilled.

## Well-established quality management system

- Basis on performance excellence model, company has set up the total quality management system covering quality management, HSE, measuring management, lab management and after-sale service. Besides, in order to fulfill the requirements stipulated in the national nuclear safety laws, regulations and guidances, nuclear power quality assurance system has been established. The requirements from the systems have been well followed in the whole process
- Company has a long-term partnership with suppliers and creates well-established supplier quality assurance system to increase the agility and openness of the supply chain. Meanwhile, company continuously improve the supply quality, supplier environment and safety performance, and ensure product quality and reliability at the sources
- ABB Group has introduced Lean Six Sigma to enhance the 4Q Improvement Method. By collecting customer feedback, using key performance indicators and target evaluation methods, the company can identify the gap in performance and goals and promote the training

of Lean Six Sigma for all employees to reduce the waste arising from the process and the non-value-added work. Lean Six Sigma uses most of the effective improvement methods, including VSM (value stream mapping), Kanban pull system, One Piece Flow, CNWIP (constant work-in-process), graphic interpretation of data, MSA (measurement system analysis), capability analysis and DOE (design of experiment) etc.

## Step forward hand in hand with win-win cooperation

The company has provided high-quality products and services for more than 3,000 key projects in China, and has been highly recognized by the customers:

- In 1998, it won the Best Quality Award of Baosteel
- In 2003, it won Excellent Supplier of Guangzhou Metro
- In 2006, it won the honor of Trustworthy Supplier for Sinopec Dushanzi Project
- In 2012, it won the Quality Management Award issued by China Nuclear Power Engineering Co., Ltd.
- In 2014, it obtained the 1E-level supplier qualification of State Nuclear Power Engineering Co., Ltd.
- In 2016, with the cloud service of remote center, it won the honor of Quality Benchmark for National Industrial Enterprises issued by the Ministry of Industry and Information Technology
- In 2018, it obtained the strategic supplier certificate issued by China Nuclear Power Engineering Co., Ltd.

## Highly integrated process management system

- Customers can get the latest information of orders by online accessing the intelligent business platform
- Highly integrated process management system includes e-commerce, SAP/ERP system, product data management (PDM), flexible manufacturing system (FMS), and manufacturing execution system (MES) which makes each process highly coordinative, quickly responds to market’s requirement and achieves maximum customer values
- Convenient electronic process platform: TQM system, supplier management platform, engineering project management e-PLAN / M

- VE, field service management platform, remote online monitoring and service platform
- Automated manufacturing equipment and systems, intelligent i-House system, AGV automated guided vehicle and other logistics management equipment, advanced high-voltage test and inspection equipment, “internet + technology” remote factory acceptance test system and remote cloud service center

- Based on the highly integrated process management system, the company has achieved in-depth integration of informatization and industrialization, successfully passed the evaluation of the national expert committee on the integration management system of Informatization and Industrialization, and obtained the certificate of integration management system of informatization and industrialization

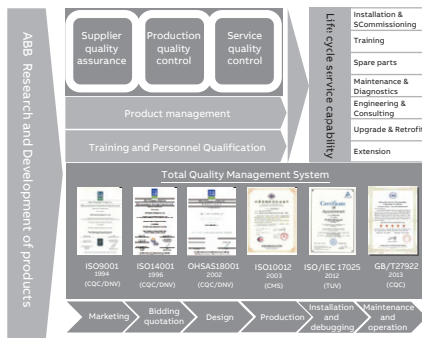

# Switchgear profit center

Switchgear profit center of ABB Xiamen Switchgear Co., Ltd. mainly produces 3.6~40.5 kV medium voltage air-insulated and gas-insulated switchgears. The company adopts multiple sales models including direct sales, channel sales and project partners (including EPC), etc.. The products are provided for over 70 countries worldwide. The delivered medium voltage switchgears have exceeded 400,000 sets and the products cover all segment including electric power, industry, petrochemical industry, real estate, transportation, and etc.

## Main products and systems

- Air-insulated switchgears
  - UniGear ZS1 used in 3~20 kV power supply and distribution system
  - UniGear ZS3.2 used in 35 kV power supply and distribution system
- Gas-insulated switchgears
  - ZX2 used in 35 kV power supply and distribution system
  - ZX0/ZX0 Air/ZX0.2 used in 3~20 kV power supply and distribution system
  - ZX1.5-R used in rail traction power supply system

- Intelligent solutions
  - iUniGear intelligent solutions
  - UniGear Digital medium-voltage digital solution
  - cPMS compact energy management system
  - COM600 intelligent substation management system

## Product development and technology innovation

Sticking to the development strategy of “In China, for China and the world”, ABB established medium voltage technology R&D center in Xiamen in 2005.

- Continuous R&D input of new products enables ABB to lead the technology of the industry all the time
- The sharing of global R&D resources ensures the advancement of the product technology
- With in-depth knowledge of local demand, the R&D products fully satisfy the localized requirements
- Lead the technology innovation and develop environment friendly switchgears
- Provide intelligent products and system solutions for power system
- Work on continuous technological innovation to create value for customers



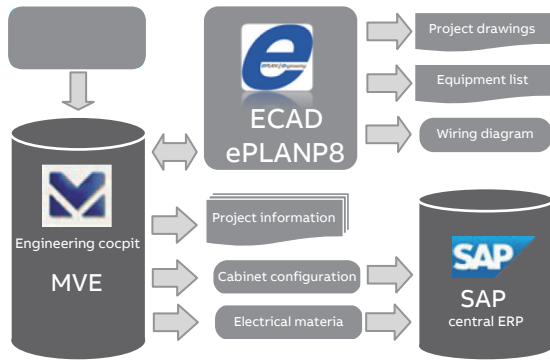

**Intelligent engineering design and professional project management**

- Use intelligent design and drawing system, which is efficient, accurate and standardized
- Realize digitization and visualization of whole production process and support lean manufacturing
- Have rich global project management experience and professional project management team
- Systematically integrate the resources and provide professional engineering technical services

**Intelligent manufacturing system**

- Customized product manufacture supported by sheet metal flexible manufacturing system
- Rapid production response capability outputted by advanced automatic assembly line
- Stable and reliable robot welding quality
- 30,000 sets of annual output capacity greatly supported by the integration-based manufacturing information system
- Perfect global supply chain system ensuring rapid response
- World leading standardized product design platform ensuring rapid delivery of customized products



UniGear ZS1 assembly line

Sheet metal bending robot



Automatic harness processing

Sheet metal workshop

As a world leading medium voltage switchgear manufacturer, we are committed to continuously improving quality concept and constantly advancing comprehensive quality management system in the whole process of product development, design, manufacturing and delivery. Besides, we have also extended the quality management control system to the suppliers and customers and transformed the customer demand into standard technical requirements of manufacturing, so as to increase customer satisfaction to the greatest extent and maximize the customer value.

Over the past 20 years, relying on continuous product innovation and sustainable development, outstanding production operation, professional engineering technical services and comprehensive quality management system, ABB has kept its leading position in the industry all the time and become the first choice of global major projects.

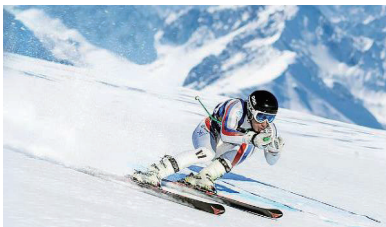

2022 Beijing Winter Olympics



Beijing Daxing International Airport



State Grid Jinhua Smart Substation



CGNPC Yangjiang Nanpeng Island Offshore Wind Power



Shenhua Ningmei



Alibaba Cloud Computing Data Center

# UniGear ZS1 - single busbar system

## Air-insulated switchgear for power application



UniGear ZS1 is the ABB mainline global switchgear for primary distribution up to 24 kV, 4 000 A, 50 kA.

The switchgear is manufactured worldwide and there are more than 400 000 panels currently installed.

UniGear ZS1 is used to distribute electric power in a variety of demanding applications such as on offshore platforms, in container or cruise ships, in mines as well as in utility substations, power plants or chemical plants.

UniGear ZS1 is available as a single busbar, double busbar, back to back or double level solution.

### Features

- Standards: IEC, CSA, GOST, GB/DL
- Design: LSC-2B, PM
- Accessibility type: A
- Internal arc class: FLR
- Highly customized versions available
- Switchgear can be back to wall installed

### Safety

- Fully type tested according to IEC 62271-200
- Fitted with safety interlocks
- Circuit breaker racking with closed doors

### Switching devices

- VD4 vacuum circuit breaker with spring actuator
- VM1 vacuum circuit breaker with magnetic actuator
- HD4 SF<sub>6</sub> circuit breaker with spring actuator
- VSC vacuum contactor with magnetic actuator
- NALF switch disconnecter

### Current and voltage measurement

- Current and voltage sensors

- Conventional current and voltage instrument transformers

### Protection and control

- Relion® protection and control relays

### Optionally available with

- Optical arc fault protection
- Ultra Fast Earthing Switch UFES
- Surge arresters
- Is-limiter, advanced fault current limiter
- Substation management unit COM600S
- Smart asset management solutions

### Technical parameters

Product catalogue	UniGear ZS1 (single level)		
Rated voltage	(kV)	12	24
Rated insulation voltage	(kV)	42/75	65/125
Rated current of main busbars	(A)	...5000	...3150
Rated current of feeders	(A)	...5000	...3150
Rated short time withstand current	(kV)	...50	...31.5
Rated peak withstand current	(kV)	...150	...80
Internal arc withstand current	(kV)	...50	...31.5
Overall dimensions of the basic cubicle	H (mm)	2200	2325
	W (mm)	650/ 800/ 1000	800/ 1000
	D (mm)	1340/ 1390	1700/ 1955

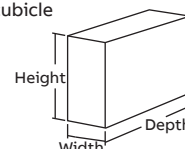

\* For detailed specification, please contact us.

# UniGear 550

Air-insulated switchgear for power application.



UniGear 550 is an air-insulated medium-voltage switchgear for primary distribution.

The innovative feature of this panel is its size. In fact, it only measures 550 mm in width which makes it a very compact and versatile product that is ideal for applications where space is restricted.

It is suitable for indoor installations and it offers a wide range of units and functions.

Optimal safety is ensured by interlocks between all switching devices and compartments doors. All types of UniGear panels (UniGear ZS1, UniGear 550, UniGear 500R, UniGear MCC) can be connected together without any adapter panels or other special means.

#### Features

- Standards: IEC, GOST, GB/DL
- Design: LSC-2B, PM
- Accessibility type: A
- Internal arc class: FLR
- Highly customized versions available
- Switchgear can be back to wall installed

#### Safety

- Fully type tested according to IEC 62271-200
- Fitted with safety interlocks
- Circuit breaker racking with closed doors

#### Switching devices

- Vmax vacuum circuit breaker with spring actuator

#### Current and voltage measurement

- Current and voltage sensors
- Conventional current and voltage instrument transformers

#### Protection and control

- Relion® protection and control relays

#### Optionally available with

- Optical arc fault protection
- Surge arresters
- Substation management unit COM600S
- Smart Asset Management solutions

**Technical data**

Rated voltage	[kV]	12	12	12	17.5
Insulation class	[kV]	12/28/75	12/42/75	12/42/75	12/38/75
Rated short time withstand current	[kA/s]	...31.5/3	...31.5/4	...31.5/4	...31.5/3
Rated peak withstand current	[kA]	...80	...80	...80	...80
Internal arc withstand current	[kA/ 1 s]	...31.5	...31.5	...31.5	...31.5
Rated current of main busbars	[A]	...4000	...4000	...4000	...4000
Rated current of feeders	[A]	...1250	630-1250	1600-2000	...1250
Test basis		IEC standards	GB standards	GB standards	IEC standards
Overall dimensions of standard cabinet		H[mm]	2200...2675	2200...2675	2200...2675
		W[mm]	550	550	550
		D[mm]	1340	1340	1390
Fitted with	Vacuum circuit breaker	[mm]	●	●	●
	Grounding switch		●	●	●
	Computer interface		●	●	●
	Instrument transformer		●	●	●

# Medium-voltage air-insulated switchgear

## UniGear ZS1

### Slim 500 mm width panel



ABB's well-known and widely accepted UniGear ZS1 is also available with a slim width panel of only 500 mm. The well-established medium-voltage switchgear offers the highest safety for personnel, enhanced switchgear reliability, and smart monitoring & diagnostic solution.

#### At a glance

- 500 mm panel width
- Withdrawable VD4 circuit breaker
- Two panels can be assembled and shipped out, which saves time during installation
- Internal arc classification IAC AFLR
- The whole cabinet has passed the condensation test
- Innovative interlock monitoring system, full range of safety for personnel
- Comprehensive monitoring and diagnostic solutions yet extendable and upgradable

#### Key benefits and features

UniGear ZS1 air-insulated metal-enclosed switchgear with a panel width of 500 mm is

#### Smaller - installation space savings up to 25%

- The slim panel is equipped with a withdrawal circuit breaker trolley, which is especially suitable for commercial real estate applications, where space is limited
- The slim panels permit the delivery of two panels already assembled together in the factory – reducing delivery time by up to 30% and on-site installation time by 10%

#### Safe

- With its optimized electric field distribution design, excellent stable insulation and temperature rise performance

- Offers an innovative interlock monitoring system for comprehensive personal safety

#### Reliable

- Comprehensive performance improvements for increased operational reliability and safety
- The circuit breaker uses PT embedded poles with a mechanical life of up to 30,000 cycles and passes through 30 full-capacity breaking tests
- Passes the condensation withstand voltage test
- Low partial discharge
- Internal arcing level is AFLR and reaches 31.5 kA/1 s
- High cable terminal heights up to 700 mm

#### Smart

Comprehensive online monitoring covering:

- Temperature rise
- Panel interlocking
- Ambient temperature and humidity
- Breaker and motorization of truck & earthing switch

Further enhancement of safety and reliability; Improve the operation and maintenance efficiency with costs reduced significantly.

#### Easy to combine

- It can be combined with the other UniGear ZS1 panel widths to meet the different needs

### Technical data

Product name		UniGear ZS1
Rated voltage	[kV]	12
Rated power frequency withstand voltage	[kV / 1 min]	42
Rated lightning impulse withstand voltage	[kV]	75
Rated frequency	[Hz]	50
Rated main busbar current (40°C)	[A]	...4000
Rated feeder current (40°C)	[A]	630, 1250
Rated short time withstand current	[kA / 4 s]	...31.5
Internal arc withstand current	[kA / 1 s]	...31.5
Standard		GB, IEC
Dimension 	H[mm]	2200
	W[mm]	500
	D[mm]	1310/1620

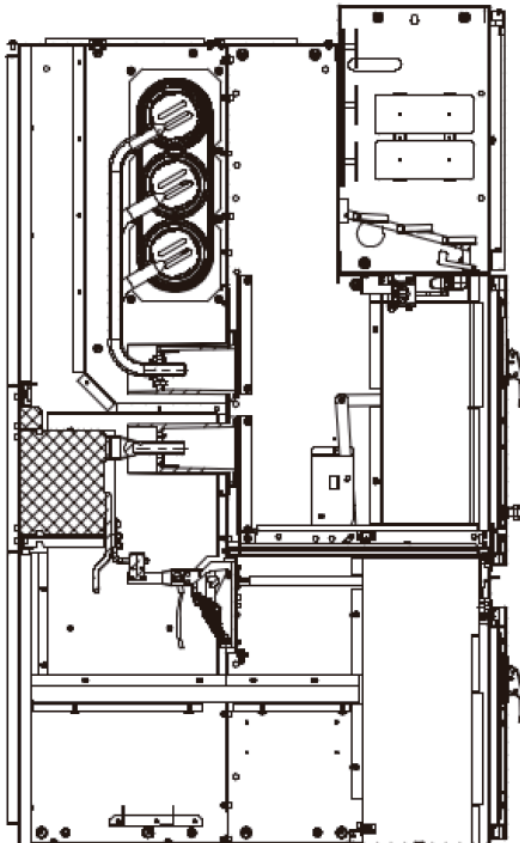

# LeanGear ZS9 metal-enclosed switchgear

## 12 kV, 630...1250 A, 25 kA



The ABB LeanGear ZS9 primary distribution switchgear is designed to meet the specific needs of the Chinese market, with key features such as a compact construction, low maintenance design and an internal arc withstand. LeanGear ZS9 provides the quality, reliability, safety, performance and high level of technical support associated with ABB's global brand.

### Features

- Floor rolling circuit breaker
- Greatly reduced height of switchgear allows for easier operation and maintenance
- Extendable on both sides
- Cable connection height of 700 mm
- Factory assembled integral gas duct
- Simple maintenance
- Compact and space saving design with reduced space requirements
- Designed for classification LSC2B - PM
- Can be offered with ABB's REF601 and other numerical relays for intelligent protection solutions

### Vind - Vacuum Circuit Breaker

- Conforms to IEC 62271-100 and GB 1984
- Floor rolling circuit breaker
- Continuous rated closing and tripping coils

- Modular circuit breaker mechanism for fast and easy maintenance
- Integral spring charging handle
- Suitable for E2, M2 & C2 (back-to-back capacitor bank) class applications
- Built-in mechanical anti-pumping device

### Safety

- Internal arc-proof construction conforming to the classification IAC AFLR up to 25 kA 0.5 s
- Closed door rack-in and rack-out of circuit breaker ensuring complete safety for the operating personnel
- Fitted with standard safety interlocks
- Provisions for padlocks on shutters, circuit breaker compartment door, racking in/out handle insertion slot and earthing switch handle insertion slot

**Technical data**

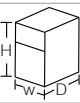
Switchgear	LeanGear ZS9		
Rated voltage	[kV]	12	
Rated power frequency withstand voltage	[kV 1 min]	42	
Rated lightning impulse withstand voltage	[kV]	75	
Rated frequency	[Hz]	50	
Rated short time withstand current	[kA 4 s]	25	
Main busbar rated current	[A]	up to 2000	
Branch connection rated current	[A]	630/1250	
Internal arc classification		IAC AFLR 25 kA 0.5 s	
Overall dimensions of basic cubicle		H[mm]	1755
		W[mm]	600
		D[mm]	1560
Cable connection height	[mm]	700	
Paint shades (for front door and end covers only)		RAL7035 light grey (other shades on request)	
Approximate weight	kg	500	

**Typical panel configurations**

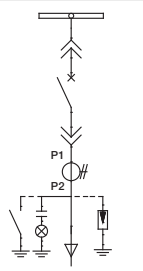
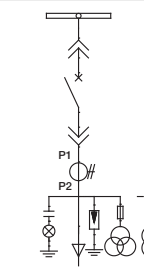
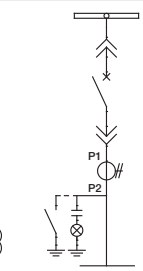
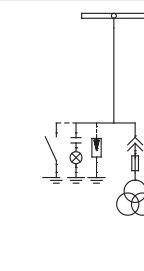
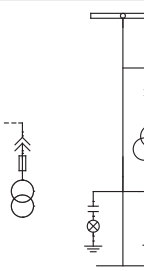
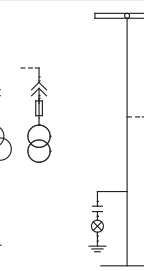
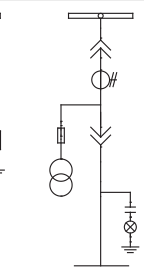
						
Incoming/ outgoing feeder Option: ES/SA	Incoming feeder with measurements Option: PT/SA	Bus tie Option: ES	Bus PT Option: ES/SA	Bus riser with PT Option: SA	Bus riser Option: SA	Measurement

**Typical feeder unit**

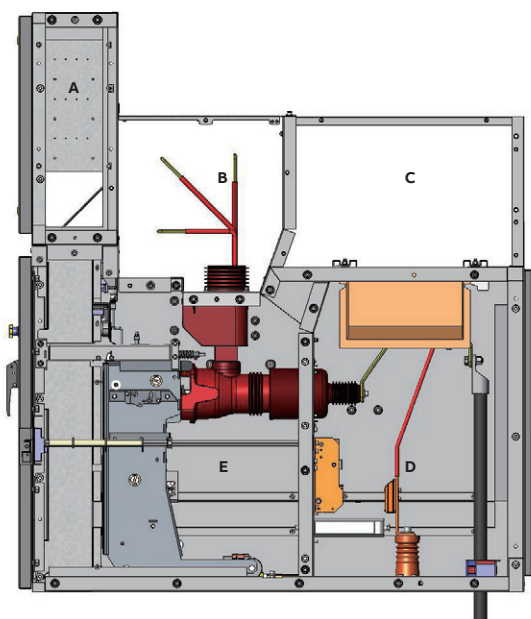

- A Low voltage compartment
- B Busbar compartment
- C Gas duct
- D Cable compartment
- E Circuit breaker compartment

# UniGear ZS3.2 metal-enclosed switchgear

## 40.5 kV, ...3150 A, ...31.5 kA



Fitted with VD4/ HD4 40.5 kV ...3150 A ...31.5 kA UniGear ZS3.2 - with advanced technical position of switchgear device.

### UniGear ZS3.2 - safety and reliability

- Metal-enclosed switchgear device
- Uniform electrical field design, main circuit coppers are covered with Raychem heat shrinkable tube that has good insulating capacity and heat dissipation
- LV compartment and between other compartments are separated with earthed metal steel
- With high speed making capacity earthing switch can making short-time circuit current
- All operations are done in front of the device with the cubicle doors closed, which contains making and breaking circuit-breaker, rocking in/out the trolley and operating earthing switch
- Reliable and safety interlock can avoid mal-operation
- There are check windows on the front and back doors. Whether the circuit-breaker is closed or opened, the earthing switch position, stored energy condition, and the cable terminal status can all be seen through the windows

### UniGear ZS3.2 - availability and flexibility

- Vacuum breaker or SF<sub>6</sub> breaker technology is available
- Circuit-breakers with the same ratings are interchangeable between switchgears
- Various panels can satisfy most customers' requirement

### UniGear ZS3.2 - suitable for all applications

- Complies with IEC and also with the Chinese "GB/T" national standards, and GOST specification
- Technical data, including high dielectric withstand capacity, allows application in most systems where electrical energy is generated, distributed or utilized
- There are maximum three power cable connection positions

### Technical data

Product catalogue	UniGear ZS3.2		
Rated voltage	(kV)	36	40.5
Rated insulation level	(kV)	70/170	95/185
Rated current of main busbars	(A)	...3150	
Rated current of feeders	(A)	...3150	
Rated short time withstand current	(kV)	...31.5	
Rated peak withstand current	(kV)	...80	
Internal arc withstand current	(kV)	...31.5	
Overall dimensions of the basic cubicle	H (mm)	2400	
	W (mm)	1200	
	D (mm)	2565	

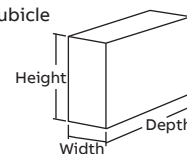

\* For more information, please consult ABB Xiamen Switchgear Co., Ltd.

# ZX0 gas insulated switchgear

## 12 kV...24 kV, ...1250 A, ...25 kA



ZX0 gas insulated switchgear adopts SF<sub>6</sub> gas as the insulating medium. Its main features include:

- Small footprint and space saving.
- Plug-in design for quick installation
- Modular design to facilitate extension
- Annual leakage rate less than 0.1%
- Mechanical interlock protecting against mal operation
- Easy to operate and maintenance-free
- High-quality material selection and high reliability
- High structural strength, resistance to internal arc fault 25 kA / 1 s, and meeting IAC-level AFLR

- Plug-in busbar connection for quick installation
  - Plug-in Busbar connection without gas work on site
  - Plug-in voltage transformers (bus side) and surge arresters
  - Wall mounted or free standing
- Modular design
  - Single busbar design
  - Individual gas compartment
  - The live part is sealed in the gas compartment, not affected by the environment
  - Easy to implement various configurations
- Environmental protection design and annual leakage rate less than 0.1%
  - Fully tested in factory and no gas work on site
- Perfect mechanical interlocking to ensure the safe operation of the power system
  - Perfect "five-prevention" mechanical interlock to prevent the operator from misoperation
- Easy to operate and maintenance-free
  - Less maintenance and saving operating costs
  - Front cable access
- High-quality material selection and high reliability
  - Improving product reliability to extend product life
- High structural strength, resistance to internal arc fault 25 kA / 1 s, and meeting IAC-level AFLR
  - Each gas chamber is equipped with a pressure relief device

### Technical parameters

Product catalogue	ZX0		
Rated voltage	(kV)	12	24
Rated insulation voltage	(kV)	42/75	50/125
Rated current of main busbars	(A)	...1250	...1250
Rated current	(A)	...1250	...1250
Rated short time withstand current 3 s	(kV)	...25	...25
Rated peak withstand current	(kV)	...63	...63
Internal arc withstand current	(kA)	...25	...25

\* For more parameters, please consult ABB Xiamen Switchgear Co., Ltd.

# ZX0 Air gas insulated switchgear

## 12 kV, ...1250 A, ...25 kA



- It adopts dry air insulation, which is truly green and environmentally friendly
  - Dry air insulation design to minimize the greenhouse effects
  - Factory package and annual leakage rate less than 0.1%
  - It is not necessary for the customer perform recycling operations
- It adopts plug-in design for quick installation
  - No gas work on site
  - CT/VT available for both busbar side and cable side
  - Wall mounted and free standing possible
- It adopts modular design to facilitate extension
  - Single busbar design and independent gas filled compartment
  - live parts are completely sealed in the gas compartment, not affected by the environment
- Perfect mechanical interlocking to ensure the safe operation of the power system
  - Mechanical interlock to prevent mal operation
- Easy to operate and maintenance-free
  - Less maintenance and saving operating costs
- High-quality material selection and high reliability
  - Improving product reliability to extend product life
- High structural strength, resistance to internal arc fault 25 kA / 1 s, and meeting IAC-level AFLR
  - Each independent gas chamber has a dedicated pressure release channel

ZX0 Air is environment friendly gas insulated switchgear, which adopts dry air as the insulating medium. Its main features include:

- It adopts dry air insulation, which is truly green and environmentally friendly
- It adopts plug-in design for quick installation
- It adopts modular design to facilitate extension
- Mechanical interlock protecting against mal operation
- Easy to operate and maintenance-free
- High-quality material selection and high reliability
- High structural strength, resistance to internal arc fault 25 kA / 1 s, and meeting IAC-level AFLR

### Technical parameters

Product catalogue	ZX0 Air	
Rated voltage	(kV)	12
Rated insulation voltage	(kV)	42/75
Rated current of main busbars	(A)	...1250
Rated current of feeders	(A)	...1250
Rated short time withstand current 3 s	(kV)	...25
Rated peak withstand current	(kV)	...63
Internal arc withstand current	(kA)	...25

\* For more parameters, please consult ABB Xiamen Switchgear Co., Ltd.

# ZX0.2 gas insulated switchgear

## 12 kV...24 kV, ...2500 A, ...31.5 kA



ZX0.2 gas insulated switchgear adopts SF<sub>6</sub> gas as the insulating medium. Its main features include:

- Small size
- It adopts plug-in design for quick installation
- It adopts modular design to facilitate extension
- Environmental protection design and annual leakage rate less than 0.1%
- Perfect mechanical interlocking to ensure the safe operation of the power system
- Easy to operate and maintenance-free
- High-quality material selection and high reliability
- High structural strength, resistance to internal arc fault 31.5 kA / 1 s, and meeting IAC-level AFLR

- Small size
  - SF<sub>6</sub> gas insulation, high current cabinet type (1600 to 2500 A) and cabinet width of only 800 mm
  - Saving infrastructure land and space
- It adopts plug-in design for quick installation
  - Solid insulated busbar design is adopted without gas recovery and supplementary operation
  - The plug-in technology is used to connect cables, voltage transformers and lightning arresters
  - The installation can be against the wall or not against the wall
- It adopts modular design to facilitate extension
  - Single busbar design and independent gas filled compartment
  - The primary charged body is completely sealed in the gas filled compartment, not affected by the environment
  - Easy to implement various configurations
- Environmental protection design and annual leakage rate less than 0.1%
  - Factory package and no need for gas supply during product life
- Perfect mechanical interlocking to ensure the safe operation of the power system
  - Perfect "five-prevention" mechanical interlock to prevent the operator from misoperation

- Easy to operate and maintenance-free
  - Fewer maintenance requirements and saving operating costs
  - The cable is mounted in front of the cabinet
- High-quality material selection and high reliability
  - Improving product reliability to extend product life
- High structural strength, resistance to internal arc fault 31.5 kA / 1 s, and meeting IAC-level AFLR. Each gas chamber is equipped with a pressure relief device

### Technical parameters

Product catalogue	ZX0.2		
		12	24
Rated voltage	(kV)	12	24
Rated insulation voltage	(kV)	42/75	65/125
Rated current of main busbars	(A)	...2500	...2500
Rated current	(A)	...2500	...2500
Rated short time withstand current 4s	(kV)	...31.5	...31.5
Rated peak withstand current	(kV)	...80	...80
Internal arc withstand current	(kV)	...31.5	...31.5

\* For more parameters, please consult ABB Xiamen Switchgear Co., Ltd.

# ZX1.2 gas insulated switchgear

## 12 kV...24 kV, ...2500 A, ...31.5 kA



ZX1.2 gas insulated switchgear adopts SF<sub>6</sub> gas as the insulating medium. Its main features include:

- Small size
  - It adopts plug-in design for quick installation
  - It adopts modular design to facilitate extension
  - Environmental protection design and annual leakage rate less than 0.1%
  - Perfect mechanical interlocking to ensure the safe operation of the power system
  - Easy to operate and maintenance-free
  - High-quality material selection and high reliability
  - High structural strength, resistance to internal arc fault 31.5 kA / 1 s, and meeting IAC-level AFLR
- Small size
    - SF<sub>6</sub> gas insulation and small cabinet size
    - Saving infrastructure land and space
  - It adopts plug-in design for quick installation
    - Busbar connection adopts plug-in technology without gas recovery and supplementary operation
    - The plug-in technology is used to connect cables, voltage transformers and lightning arresters
  - It adopts modular design to facilitate extension
    - Single busbar design and independent gas filled compartment
    - The primary charged body is completely sealed in the gas filled compartment, not affected by the environment
    - Easy to implement various configurations
  - Environmental protection design and annual leakage rate less than 0.1%
    - Factory package and no need for gas supply during product life
  - Perfect mechanical interlocking to ensure the safe operation of the power system
    - Perfect "five-prevention" mechanical interlock to prevent the operator from misoperation
  - Easy to operate and maintenance-free
    - Fewer maintenance requirements and saving operating costs
  - High-quality material selection and high reliability
    - Improving product reliability to extend product life
- High structural strength, resistance to internal arc fault 31.5 kA / 1 s, and meeting IAC-level AFLR
    - Each independent gas chamber has a dedicated pressure release channel

### Technical parameters

Product catalogue	ZX1.2		
Rated voltage	(kV)	12	24
Rated insulation voltage	(kV)	42/75	65/125
Rated current of main busbars	(A)	...2500	...2500
Rated current of feeders	(A)	...2500	...2500
Rated short time withstand current 3 s	(kV)	...31.5	...31.5
Rated peak withstand current	(kV)	...80	...80
Internal arc withstand current	(kV)	...31.5	...31.5

\* For more parameters, please consult ABB Xiamen Switchgear Co., Ltd.

# ZX1.5-R gas - insulated metal - enclosed switchgear for railway electrification

27.5/2x27.5 kV, ...2500 A, ...31.5 kA



ZX1.5-R is a unipolar and bipolar gas insulated medium-voltage switchgear specially designed and developed for electrified high-speed railway traction system. Main features of the switchgear include:

- Small size
  - It adopts plug-in design for quick installation
  - It adopts modular design to facilitate extension
  - Environmental protection design and annual leakage rate less than 0.1%
  - Perfect mechanical interlocking to ensure the safe operation of the power system
  - Easy to operate and maintenance-free
  - High-quality material selection and high reliability
  - High structural strength, resistance to internal arc fault 31.5 kA / 1 s, and meeting IAC-level AFLR
- 
- Small size
    - SF<sub>6</sub> gas insulation and small cabinet size
    - The miniaturized switchgear saves infrastructure land and space to significantly reduce the total investment cost
  - It adopts plug-in design for quick installation
    - Busbar connection adopts plug-in technology without gas recovery and supplementary operation
    - The plug-in technology is used to connect cables, voltage transformers and lightning arresters
  - It adopts modular design to facilitate extension
    - Single busbar system for unipolar and bipolar 25 kV system applications
    - The primary charged body is completely sealed in the gas filled compartment, not affected by the environment
    - Easy to implement various configurations
  - Environmental protection design and annual leakage rate less than 0.1%
    - Factory package and no need for gas supply during product life
  - Perfect mechanical interlocking to ensure the safe operation of the power system
    - Perfect "five-prevention" mechanical interlock to prevent the operator from misoperation
  - Easy to operate and maintenance-free
    - Fewer maintenance requirements and saving operating costs
- 
- High-quality material selection and high reliability
    - Improving product reliability to extend product life
  - High structural strength, resistance to internal arc fault 31.5 kA / 1 s, and meeting IAC-level AFLR
    - Each independent gas chamber has a dedicated pressure release channel

### Technical parameters

Product catalogue	ZX1.5-R		
Rated voltage	(kV)	27.5	2X27.5
Rated insulation voltage	(kV)	95/200	95/200
Rated current of main busbars	(A)	...2500	...2500
Rated current	(A)	...2500	...2500
Rated short time withstand current 3s	(kV)	...31.5	...31.5
Rated peak withstand current	(kV)	...80	...80
Internal arc withstand current	(kV)	...31.5	...31.5

\* For more parameters, please consult ABB Xiamen Switchgear Co., Ltd.

# ZX2 gas insulated switchgear

## 40.5 kV, ...2500 A, ...40 kA



ZX2 gas insulated switchgear adopts SF<sub>6</sub> gas as the insulating medium. Main features of the switchgear include:

- It has a small size to save space
  - It adopts plug-in design for quick installation
  - It adopts modular design to facilitate extension
  - Environmental protection design and annual leakage rate less than 0.1%
  - Perfect mechanical interlocking to ensure the safe operation of the power system
  - Easy to operate and maintenance-free
  - High-quality material selection and high reliability
  - High structural strength, resistance to internal arc fault 40 kA / 1 s, and meeting IAC-level AFLR
- It has a small size to save space
    - SF<sub>6</sub> gas insulation and small cabinet size
    - The miniaturized switchgear saves infrastructure land and space to significantly reduce the total investment cost
  - It adopts plug-in design for quick installation
    - Busbar connection adopts plug-in technology without gas recovery and supplementary operation
    - The plug-in technology is used to connect cables, voltage transformers and lightning arresters
  - It adopts modular design to facilitate extension
    - Single and double busbar design is adopted, and gas chambers are independent of each other
    - The primary charged body is completely sealed in the gas filled compartment, not affected by the environment
    - Easy to implement various configurations
  - Environmental protection design and annual leakage rate less than 0.1%
    - Factory package and no need for gas supply during product life
  - Perfect mechanical interlocking to ensure the safe operation of the power system
    - Perfect "five-prevention" mechanical interlock to prevent the operator from misoperation
  - Easy to operate and maintenance-free
    - Fewer maintenance requirements and saving operating costs
- High-quality material selection and high reliability
    - Improving product reliability to extend product life
  - High structural strength, resistance to internal arc fault 40 kA / 1 s, and meeting IAC-level AFLR
    - Each independent gas chamber has a dedicated pressure release channel

### Technical parameters

Product catalogue	ZX2	
Rated voltage	(kV)	40.5
Rated insulation voltage	(kV)	95/185
Rated current of main busbars	(A)	...2500
Rated current	(A)	...2500
Rated short time withstand current 3s	(kV)	...40
Rated peak withstand current	(kV)	...100
Internal arc withstand current	(kV)	...40

\* For more parameters, please consult ABB Xiamen Switchgear Co., Ltd.

# New breakthrough of ABB gas insulated switchgear

## Significantly reducing global warming potential



### ABB environment friendly medium-voltage gas insulated switchgear ZX2 AirPlus

ZX2 AirPlus adopts an innovative gas technology to break through the existing technical limitations. It uses enhanced air to achieve environmental protection under the premise of micro positive pressure and miniaturization, which retains the compactness of GIS and all other advantages. And the global warming potential (GWP) of new gases is less than 1, greatly reducing the impact on the environment. Compared with the classic design of ZX2 which has been tested through decades of practice, ZX2 AirPlus remains unchanged in the overall dimensions, performance parameters, operating habits and core components while keeping safe and reliable as always. Environmental solutions of ABB AirPlus will open a new era of green switchgear and ecological substations.

#### Product features

- It is environment friendly with global warming potential (GWP) <1
- Avoiding suffocation hazards that may result from SF<sub>6</sub> leaked in enclosed spaces
- No SF<sub>6</sub> detection device is needed for the switching station to save investment

- As compact as SF<sub>6</sub> switchgear
- Same charge pressure as SF<sub>6</sub>: micro-positive pressure
- Same operation method as SF<sub>6</sub>
- Developed based on mature products proven reliable and safe as always
- Retaining all the advantages of GIS

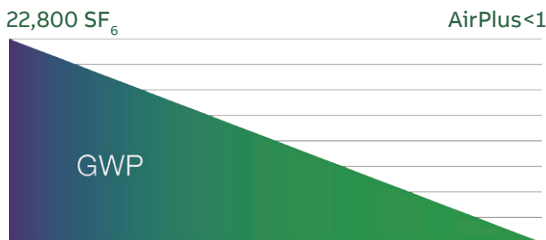

# iUniGear smart solution

iUniGear smart solution leads further development of substation, it is ready for smart grid evolution.

iUniGear is a smart solution based on MV power system, it secures the safety and reliability of power supply with online monitoring the real-time condition of switchgear. To reduce unscheduled maintenance and improve productivity, it also brings the benefits of IEC 61850 standard to the substation.

### Switchgear smart control

- Sequence control
- Video online monitoring system

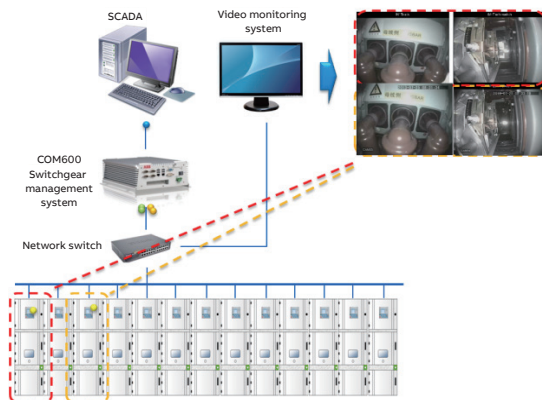

### cPMS intelligent energy management system

- Finishing judgment within 10 ms and completing load reduction within 90 ms
- Completing load reduction before the frequency changes
- Reliable load reduction according to preset procedures and real-time conditions
- 19 levels of effective load reduction used to achieve fine load reduction

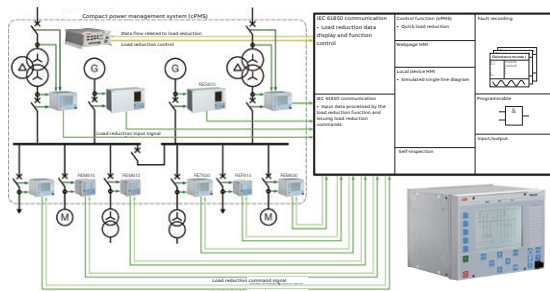

### Switchgear smart management

- Temperature online monitoring
- CB feature condition monitoring
- Switchgear condition diagnosis
- CB remaining life analysis
- Expert diagnosis system
- Remote expert system (cloud service)

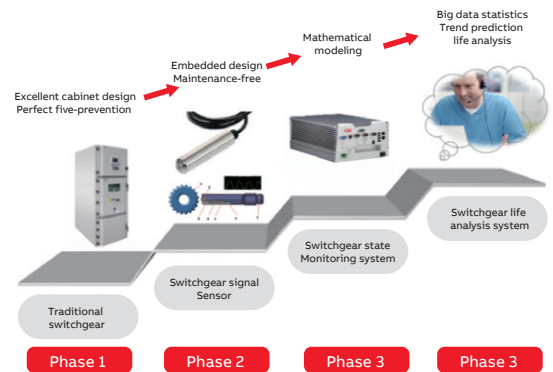

### IEC 61850 / GOOSE network information technology application

- The test verification of the intelligent remote trip protection scheme based on IEC 61850 / GOOSE technology is completed for urban rail transit at the National Cape Laboratory
- Arc protection with GOOSE, fast tripping reduces the risk of personal injuries & property damage
- GOOSE check involves online monitoring GOOSE message flow via visualization to ensure network safety

# UniGear digital digital solution of medium-voltage switchgear



UniGear Digital is a digital solution for medium-voltage switchgear developed by ABB Group to realize digital substation and improve the stability and reliability of power grid operation. UniGear Digital follows the excellent features of UniGear series products, and also shows the following advantages.

**Higher safety**

- The sensor has no iron core, which can avoid the ferromagnetic resonance problem of traditional transformers caused by system disturbance
- Low secondary output voltage to ensure the safety of the operator

**More flexibility**

- The measuring range is wide, so that the transformer is not replaced like traditional switchgear when load changes
- Digital communication technology conforms to IEC61850 communication protocol, so that the transformation of the switchgear function can be performed only by modifying the software of relay protection device

**More environmentally friendly**

- The operating loss of the sensor is negligible
- Compact structure design is adopted, for which less epoxy resin is used

**Less project investment**

- The voltage sensor is directly mounted in the busbar room to replace the traditional busbar PT cabinet, thereby eliminating the busbar PT cabinet; GOOSE communication technology is used to reduce the use of secondary hard wiring

**More intelligent digital substation**

- Digital communication function can perform the

- self-check in real time, to prevent and discover equipment problems in time and formulate a response plan
- GOOSE technology can realize the sharing of digital signals for switching value of primary equipment and processbus process bus can realize the horizontal sharing of digital signals for sampling value, so as to perform more complex and comprehensive protection functions
- It can meet IEC61850 and improve the networking level of substations and interoperability of devices to truly realize digital substations

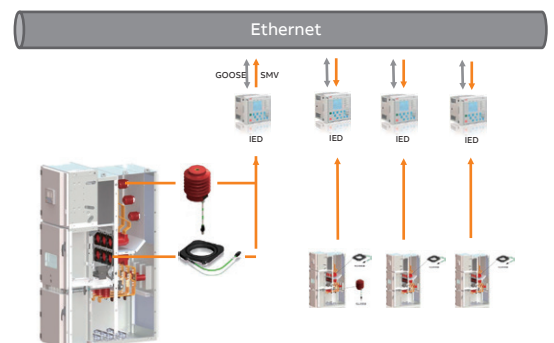
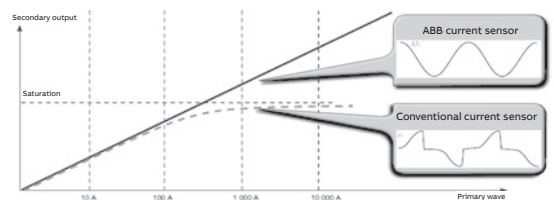

# Component division

The component factory of ABB Xiamen Switchgear Co., Ltd. is the world's largest component manufacturing base of ABB Group, and it is also the leading medium-voltage circuit breaker manufacturer. It mainly produces 3.6 ~ 40.5 kV medium-voltage indoor and outdoor components. It is OEM-oriented and adopts a variety of flexible business models such as distribution, direct sales, cooperative production, and technical cooperation to provide various main components of medium-voltage switches for domestic and foreign manufacturers. And it has cumulatively delivered more than 900,000 medium-voltage circuit breakers. Its products are widely used in power, industry, petroleum and petrochemical, real estate and transportation industries.

## Main products and application

- Indoor circuit breaker and contactor
  - VD4 vacuum circuit breaker for 3~35 kV power system
  - VSC vacuum contactor for 3~10 kV power system
  - ConVac contactor for 3~10 kV power system
  - GSR + circuit breaker for railway traction transformer system
  - HD4 SF<sub>6</sub> circuit breaker for 40.5 kV power system
- Outdoor component products
  - OVB-VBF outdoor vacuum circuit breaker
  - PVB /PVB-S pole-mounted vacuum circuit

- breaker
  - FSKII+ /FSKII-C outdoor vacuum circuit breaker for railway
  - Sectos pole-mounted SF<sub>6</sub> load switch
  - NPS pole-mounted load-disconnector
  - DCD pole-mounted single-phase disconnector
  - NCX and ICX drop-out fuse
  - DCDL low-voltage fuse type disconnector
- GIS switchgear circuit breaker
  - VD4X and VD4X0 circuit breaker for 3~35 kV power system
- Preassembled modules
  - Power Cube for 3~20 kV power system
- Smart solution
  - iVD4® smart solution for MV circuit breaker

Technology development and innovation ABB insists on "in China, For China" strategy, dedicates to create more value to our customer

- An independent ABB medium-voltage technology R&D center in China
- Steadily growing research spending and share ABB worldwide resources to maintain ABB leading position
- Insight into local market to meet the requirements
- Technology innovation, focusing on green concept
- Offering smart products and solutions for power system



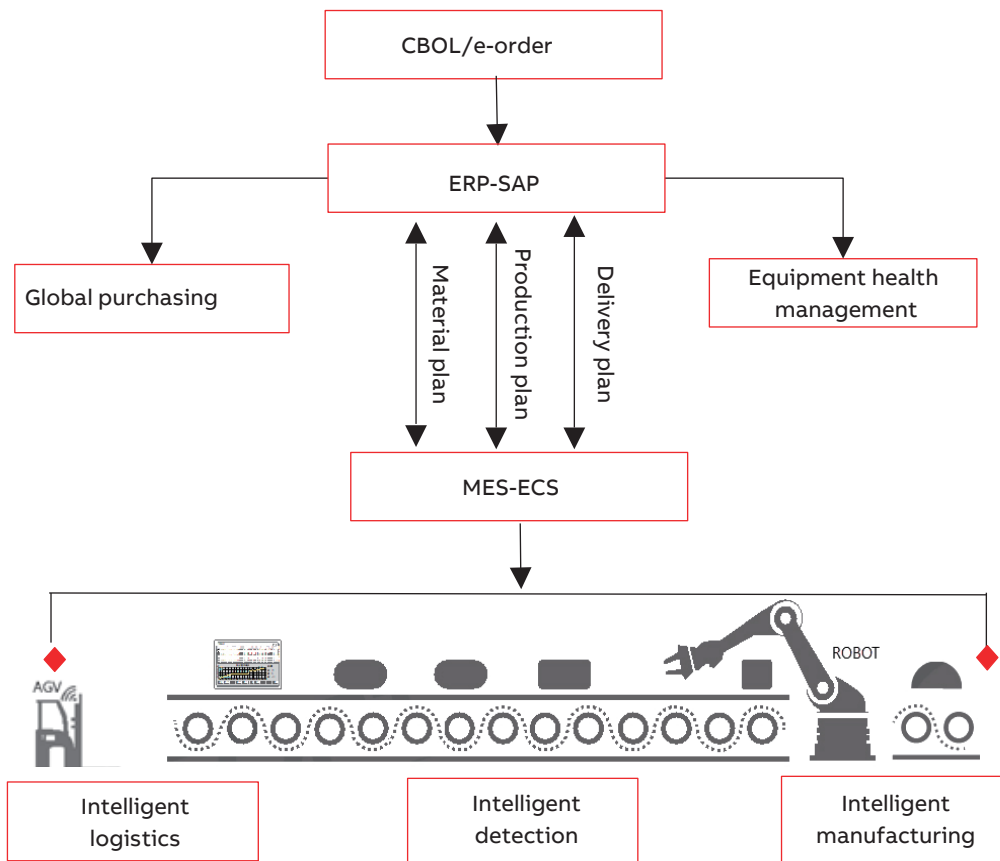

**Smart component factory**

- CBOL / e-order: online orders for customers and partners
- ASCC: supplier collaboration system
- ABB ECS: manufacturing execution system
- PRP/MRC: product lifecycle management
- Intelligent logistics and manufacturing
  - SAP / WMS / ihouse warehouse system
- Intelligent three-dimensional storehouse
- Intelligent AGV handling
- Full-process parts bar code tracing and intelligent identification of RFID products
- Intelligent pole fastening system, ABB robot welding
- Automatic testing (mechanical run-in, pressure resistance, final inspection)



Smart warehouse



Intelligent detection equipment

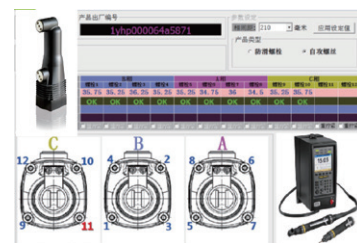

Automatic pole assembly



AGV

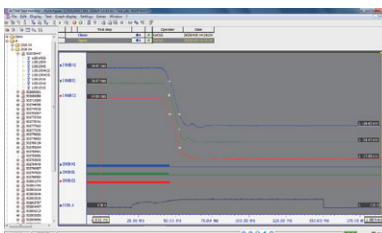

Intelligent detection system



Welding robot

As a world leading medium voltage switchgear manufacturer, we are committed to continuously improving quality concept and constantly advancing comprehensive quality management system in the whole process of product development, design, manufacturing and delivery. Besides, we have also extended the quality management and control system to the suppliers and customers, so as to increase customer satisfaction to the greatest extent and maximize customer value.

Over the past 20 years, relying on continuous product innovation and sustainable development, ABB has kept its leading position in the industry all the time and become the first choice of global major projects.



Beijing Bird's Nest



State Power Corporation Building



Beijing Daxing International Airport

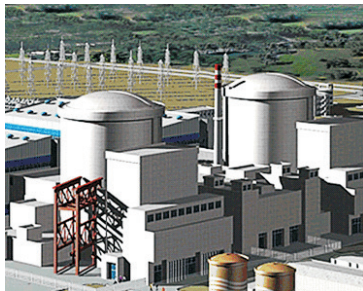

Qinshan Nuclear Power Plant



Hengli Petrochemical



High-speed railway

# VD4 vacuum circuit breaker

12 kV...24 kV, 630...5 000 A, 20...50 kA



- Global products with excellent performance
  - Executes company unified products standard, ensure the high quality for every countries
- Abundant running experience, meet different requirements
- The world's largest manufacturer of MV circuit breaker, over 1 million safety experience
  - Meet -25°C low temperature application
  - Widely used for KYN and other cabinet types in China
- Original Germany-made vacuum interrupter
  - Absorbed rigorous design and technologies from Germany
  - Optimized the reliability and the life time of products
- Durable and stable performance of modular operating mechanism
  - Precise operating with stable performance
  - Mechanical life up to 40,000 operations
- Green manufacturing and operation, environment friendly
  - Implement RoHS standards, reduce the environment pollution
  - Energy conservation, reducing approximate 3,000 ton/year CO<sub>2</sub> emission
- Easy use of intelligent solution
  - Available to add intelligent function such as: remote control, temperature online monitoring
  - Available for smart substation upgrading

VD4 vacuum circuit breaker uses ABB's well-known vacuum arc extinguishing chamber, cast-in pole with a new generation of insulating materials and operating mechanism with functional modular design. Its main features include:

- Global products with excellent performance
- Abundant running experience, meet different requirements
- Original Germany-made vacuum interrupter
- Durable and stable performance of modular operating mechanism
- Green manufacturing and operation, environment friendly
- Intelligent solution upgrading available
- The world's top operation system, high quality and rapid delivery

- The world's top operation system, high quality and rapid delivery
  - Annual output of circuit breaker up to 70,000 units
  - Efficient production and fast order handing process

## Technical Parameters

Description	VD4		
Rated Voltage	Ur[kV]	12	24
Power frequency withstand voltage	Ud (1 min) [kV]	42	65
Lightning impulse withstand voltage	Up[kV]	75	125
Rated frequency	Fr[Hz]	50/60	50/60
Rated current	Ir[A]	630...5000	630...3150
Rated short circuit breaking current	Isc[kA]	25...50	20...31.5
Rated short time withstand current (4 s)	Ik[kA]	25...50	20...31.5
Rated making capacity	Ip[kA]	63...125 <sup>1)</sup>	63...80
Operation sequence	-	[0-0.3 s-CO-15 s-CO]	
Opening time	[ms]	33~60	
Arcing time	[ms]	10~15	
Closing time	[ms]	50~80	

1) It can provide solutions up to 150 kA.

# iVD4®

## Smart solution of MV switch

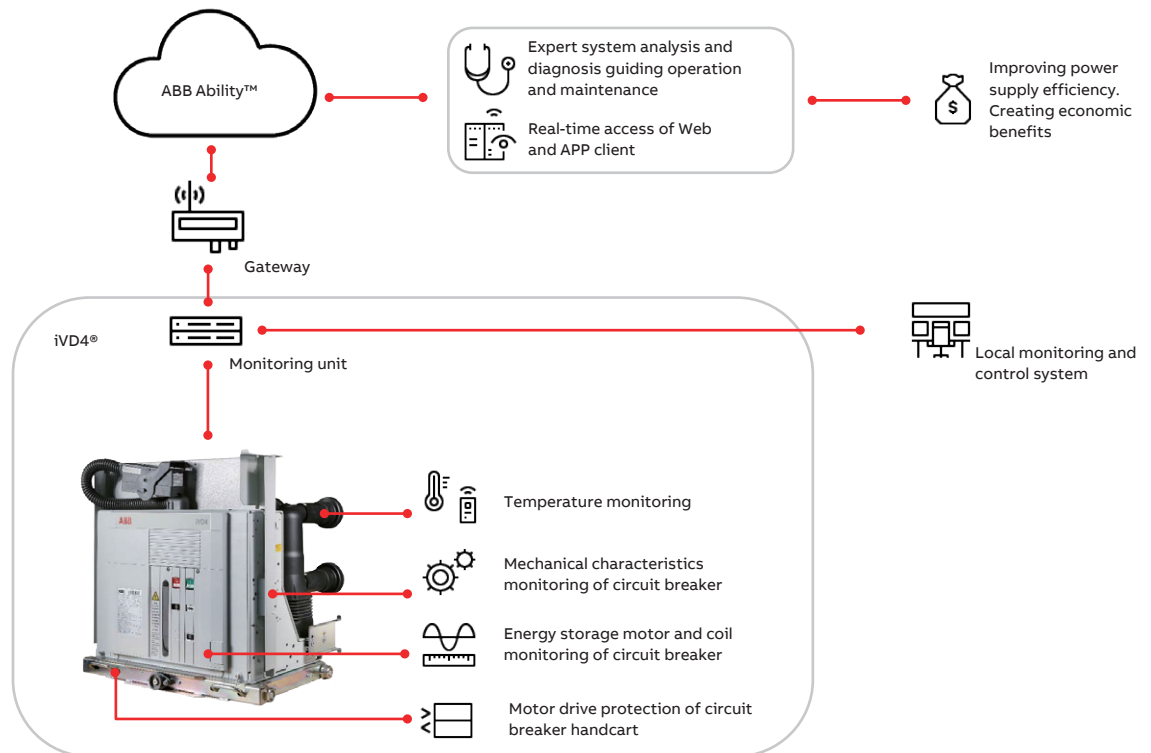

Smart solution of iVD4® MV switch takes ABB's advanced VD4 vacuum circuit breaker as a platform to manage circuit breaker health through multi-dimensional operation monitoring. Using ABB Ability™ cloud technology, it provides circuit breaker health scores, operation and maintenance recommendations and plans to improve operation continuity and reliability, extend maintenance intervals and reduce maintenance costs.

### Perfect solution of switchgear asset health management

- Intelligent real-time monitoring of switchgear temperature can be used to dynamically predict the hidden danger for the main circuit of the switchgear based on the operating current
- Circuit breaker mechanism status and mechanical characteristics are monitored online, and the mechanical movement health status of circuit breaker is clear and intuitive
- Intelligent motor drive control and protection system is used for "one-key sequence control" program operation to achieve safe and efficient operation and maintenance
- User monitoring is combined with ABB cloud

technology to perform real-time data analysis; through accurate prediction of early failures in the circuit breaker, health status is controlled





- Access running data by mobile client or browser anytime and anywhere, and support Android, iOS and Windows operating systems















### Mature and flexible solution configuration

- Convenient installation method is commonly used for center-mounted switchgear, and the function upgrade is simple and convenient
- The mature and intelligent smart solution is used to quickly build intelligent switchgear and compatible with ABB MV switchgear
- Smart solutions, circuit breakers and switchgear have passed strict test verification to meet the needs of different customers and applications
- Complete test verification is conducted according to NB/T 42044 3.6 kV~40.5 kV intelligent AC metal-enclosed switchgear and control equipment

**Leap-forward transition from passive operation and maintenance and preventive maintenance to predictive maintenance is achieved to make the operation and maintenance easier.**

**Product configuration**

-  + - Temperature monitoring for the main circuit of the circuit breaker (6 points) can be conducted at the switchgear busbar or / and the junction of the cable head
-  Monitoring of secondary devices (energy storage motor, closing and opening coil)
-  Condition monitoring of circuit breaker mechanism
-  Circuit breaker health assessment - asset health management center
-  Motor drive function of circuit breaker handcart

Recommended version	Function description
iVD4 temperature management	
iVD4 Enhanced	 
iVD4 temperature electric drive type	 
iVD4 temperature management - cloud diagnosis	 
iVD4 Enhanced - cloud diagnosis	  
iVD4 health assessment type	   

\* If you need to order other function combinations, please consult ABB.

# VSC vacuum contactor

## 7.2...12 kV, 400 A



- Global products with excellent performance
  - Executes company unified products standard, ensure the high quality for every countries
- Abundant running experience, meet different requirements
  - Global safe operation experience
  - Different mounting brackets with locking mechanism can be matched with fuses under DIN or BS standards
- Original Germany-made vacuum interrupter
  - Absorbed rigorous design and technologies from Germany
  - Optimized the reliability and the life time of products
- Bistable permanent magnet operating mechanism with stable performance and long operating life
  - Linear drive coaxial with vacuum interrupter has stable parameter output
- Passing third-party 1,000,000-time mechanical life test
  - Higher than standard type test
- Green manufacturing and operation, environment friendly
  - Extremely limited energy consumption (5 W for constant power supply)
  - Power saving up to 30,000 kWh in its life cycle
- The world's top operation system, high quality and rapid delivery
  - Efficient production and fast order handing process

VSC vacuum contactor using permanent magnet operating mechanism and world-famous vacuum interrupter, especially applicable for frequent operation:

- Global products with excellent performance
- Abundant running experience, meet different requirements
- Original Germany-made vacuum interrupter
- Bistable permanent magnet operating mechanism with stable performance and long operating life
- Passing third-party 1,000,000-time mechanical life test
- Green manufacturing and operation, environment friendly
- Efficient production and fast order handing process

### Technical parameters

Description	VSC		
Rated voltage	Ur[kV]	7.2	12
Power frequency withstand voltage	Ud (1min) [kV]	30	42
Lightning impulse withstand voltage	Up[kV]	60	75
Rated current	Ie[A]	400 <sup>1)</sup>	
Rated short-time withstand current (1 s)	Ik[kA]	6	
Rated peak withstand current	Ip[kA]	15	
Mechanical life	[N.]	1,000,000	
Electrical life (AC1)	[N.]	1,000,000	
Electrical life (AC3)	[N.]	100,000	
Opening time	[ms]	35~60	
Closing time	[ms]	60~90	
Working temperature	[°C]	-15...+40	

1) Depending on the capacity of the fuse when the fuse support is allocated.

# VD4 vacuum circuit breaker

40.5 kV, 1250...3150 A, 25...31.5 kA

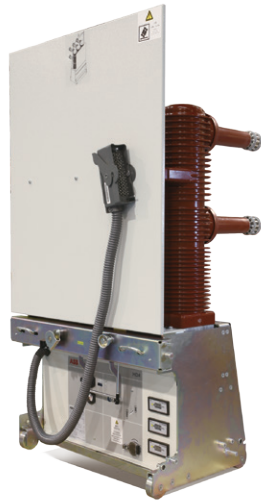

- Global products with excellent performance
  - Executes company unified products standard, ensure the high quality for every countries
- Abundant running experience, meet different requirements
  - Widely used for KYN and other cabinet types in China
  - C2 capacitor bank switching up to 800 A
- Original Germany-made vacuum interrupter
  - Absorbed rigorous design and technologies from Germany
  - Optimized the reliability and the life time of products
- Durable and stable performance of spiral spring mechanism
  - Cam design leads to smooth performance against bouncing, requires no shock absorber
- Green manufacturing and operation, environment friendly
  - Implement RoHS standards, reduce the environment pollution
- Available for intelligent solution upgrading
  - Available to add intelligent function such as: remote control, online temperature monitoring
  - Available for smart substation upgrading
- The world's top operation system, high quality and rapid delivery
  - Efficient production and fast order handing process

VD4 40.5 kV vacuum circuit breaker adopts world-famous vacuum interrupter, new embedded technology and classical spiral spring mechanism:

- Global products with excellent performance
- Abundant running experience, meet different requirements
- Original Germany-made vacuum interrupter
- Durable and stable performance of spiral spring mechanism
- Green manufacturing and operation, environment friendly
- Available for intelligent solution upgrading
- Efficient production and fast order handing process

## Technical Parameters

Description	VD4	
Rated Voltage	Ur[kV]	40.5
Power frequency withstand voltage	Ud(1min) [kV]	95 <sup>1)</sup>
Lightning impulse withstand voltage	Up[kV]	185 <sup>1)</sup>
Rated current	Ir[A]	1250...3150 <sup>2)</sup>
Rated short circuit breaking current	Isc[kA]	25...31.5
Rated short time withstand current (4 s)	Ik[kA]	25...31.5
Rated making current	Ip[kA]	63...80
Opening time	[ms]	33~45
Arcing time	[ms]	10~15
Closing time	[ms]	55~67
Working temperature	[°C]	-15...+40 <sup>3)</sup>

1) The power frequency withstand voltage / lightning impulse withstand voltage at the vacuum break of the circuit breaker is 118/215 kV.

2) Forced air cooling is required.

3) When the operating environment temperature is lower than -15 °C, please consult the manufacturer.

# HD4 SF<sub>6</sub> circuit breaker

## 40.5 kV, 1250...3150 A, 25...31.5 kA

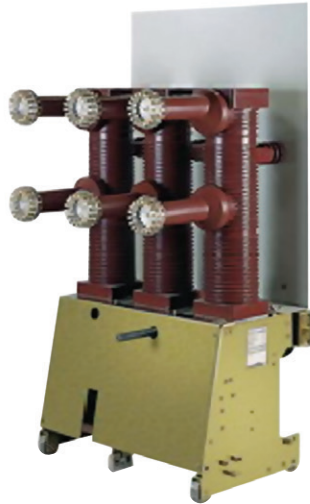

Using sulfur hexafluoride gas (SF<sub>6</sub>) to extinguish the electric arc and as the insulating medium, especially suitable for capacitive and inductive load applications such as motors, compensation reactors, capacitor banks:

- Global products with excellent performance
- Abundant running experience, meet different requirements
- Full rang of original SF<sub>6</sub> poles with high reliability
- Electric arc extinction without chopped current
- Available for upgrade of intelligent solution
- The world's top operation system, high quality and rapid delivery

- Global products with excellent performance
  - Executes company unified products standard, ensure the high quality for every countries
- Abundant running experience, meet different requirements
  - Widely used for KYN and other cabinet types in China
  - It can be fitted with digital SF<sub>6</sub> gas pressure monitoring device
- Full rang of original SF<sub>6</sub> poles with high reliability
  - Optimized the reliability and the life time of products
- Interruption-free arc extinguishing technology is used to reduce the risk of operating overvoltage
  - SF<sub>6</sub> thermal expansion + compressed air assisted arc extinguishing technology is used without interception, reignition and operating overvoltage
- Available for intelligent solution upgrading
  - Available to add intelligent function such as remote control, online temperature monitoring
  - Available for smart substation upgrading
- Efficient production and fast order handing process
  - Efficient production and fast order handing process

### Technical parameters

Description	HD4	
Rated voltage	Ur[kV]	40.5
Power frequency withstand voltage	Ud(1 min) [kV]	95
Lightning impulse withstand voltage	Up[kV]	185
Rated current	Ir[A]	1250...3150 <sup>1)</sup>
Rated short circuit breaking current	Isc[kA]	25...31.5
Rated short time withstand current (4 s)	Ik[kA]	25...31.5
Rated making current	Ip[kA]	63...80
Operation sequence	-	[O-0.3 s-CO-180 s-CO]
Opening time	[ms]	33~65
Arcing time	[ms]	60~100
Closing time	[ms]	≤80
Working temperature	[°C]	-15...+40 <sup>2)</sup>

1) Force cooling.

2) When the operating environment temperature is lower than -15 °C, please consult the manufacturer.

# ConVac vacuum contactor

## 7.2... 12kV, 400 A



As a new generation of ABB's MV vacuum contactor, ConVac vacuum contactor is developed by ABB R&D centers in China, Germany and Italy through full cooperation. Its main features include:

- Global products with excellent performance
- Full range of original German ABB vacuum arc extinguishing chamber with high reliability
- Modular plug-in design to facilitate installation and debugging
- More excellent insulation and mechanical properties
- Compact structure and flexible installation method

- Global products with excellent performance
  - Executes company unified products standard, ensure the high quality for every countries
  - Compliance with major international / domestic standards such as GB, IEC and UL
- Full range of original German ABB vacuum arc extinguishing chamber with high reliability
  - Absorbed rigorous design and technologies from Germany
  - Improving product reliability and prolonging product service life Modular plug-in design to facilitate installation and debugging
  - Saving wiring time by 40%
  - Replacement of the module does not affect the characteristic parameters of the contactor, and no additional debugging is required
- Simple and quick change between different types and configurations
  - More excellent insulation and mechanical properties
  - Three-phase independent pole design
  - Linear drive structure design to reduce mechanical stress
  - Fewer parts and longer life
- Compact structure and flexible installation method
  - Innovative linear drive structure design for smaller size and space saving
  - A variety of installation methods and optional front and rear wiring methods facilitate the design and connection of the main circuit and reduce the complexity and usage of copper

bars in the cabinet

### Technical parameters

Description	Unit	ConVac 7	ConVac 12
		ConVac 7/P	ConVac 12/P
Rated voltage	kV	7.2	12
Power frequency	kV	30	42
withstand voltage			
Lightning impulse	kVp	60	75
withstand voltage			
Rated current	A	400	400
Short time withstand current	A	4000	4000
Peak withstand current	kAp	10	10
Overload withstand	A	6000	6000
current (1 s)			
Overload withstand	A	2400	
current (30 s)			
Short-circuit breaking	kA	5	5
capacity			
Short-circuit making	kAp	12.5	12.5
capacity			
Utilization category		AC-4	
Mechanical life	Electrical	Times	1,000,000
	self-hold type		
Mechanical life	Mechanical	Times	100,000
	self-hold type		
Operating environment temperature	°C	-15...+40	

# PowerCube preassembled modules and enclosures

12...24 kV, 630...2000 A, 25...40 kA



PB/M

PB/E

PB/F

PowerCube adopts compound insulation technology, and its main features include:

- Modular design for simple structure and easy installation
- Abundant running experience, meet different requirements
- With complete interlock for safety running
- Excellent raw material selection
- Various cooperation model with OEMs

- Modular design for simple structure and easy installation
  - Continue the high reliability of ABB switchgear
- Flexible schematic design to meet different needs of users
  - Available in different versions: PB/M, PB/E and PB/F
  - It can be fitted with VD4 vacuum circuit breaker, VSC contactor, HD4 SF<sub>6</sub> circuit breaker and other withdrawable main switch components
- With complete interlock for safety running
  - Prevent the operator from misoperation and avoid power system failures
- Excellent raw material selection
  - Optimized the reliability and the life time of products
- Various cooperation model with OEMs

## Technical parameters

Description	PowerCube		
Rated voltage	Ur[kV]	12	24
Power frequency withstand voltage	Ud (1 min) [kV]	42	65
Lightning impulse withstand voltage	Up[kV]	75	125
Rated frequency	Fr[Hz]	50	
Rated current	Ir[A]	...2000	...1250
Rated short time withstand current (4 s)	Ik[kA]	25...40	25
Rated peak withstand current	Ip[kA]	63...100	63
Working temperature	[°C]	-15...+40	

# Sectos pole-mounted SF<sub>6</sub> load switch

## 12 kV...36 kV, 630 A

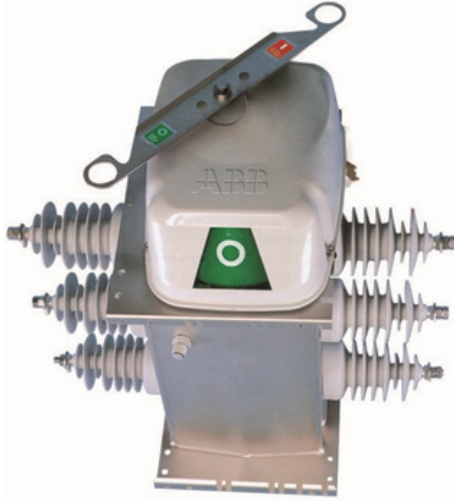

Sectos load switch is a pole-mounted switchgear at rated voltage 12-36 kV, which can break the load current and make the fault current. It is used not only for traditional overhead lines, but also for the overhead lines with insulated conductors. It can be fitted with current transformer, voltage transformer and remote control box (including RTU) to realize a variety of distribution network automation solutions.

- Global universal products with excellent performance
  - Widely used in more than 60 countries around the world
- Rich operating experience to meet the needs of different customers
- Designed specifically for modern distribution automation systems
- Taking SF<sub>6</sub> as arc extinguishing and insulating medium, with strong arc extinguishing capability
- The current box is made of 3 mm high-quality ANSI 304 stainless steel, and processed by laser cutting, CNC bending and robot welding to ensure the high strength and sealing of the box
- Vacuum helium inspection process is used to ensure the tightness of each box. The annual leakage rate of SF<sub>6</sub> is far lower than the requirements of relevant standards
- Many different pole-mounted installation methods
- Suitable for all kinds of severe climatic conditions, such as salt fog, sand, snow, humidity and industrial pollution
- It can be fitted with an Intelligent control box to realize a variety of distribution network automation solutions
  - Current counting scheme
  - Voltage time scheme
  - Boundary switch scheme

### Technical parameterst

Description	Unit	NXB&NXBD	NXA	
Rated voltage	kV	12	24	36
Power frequency withstand voltage	kV	42	50	70
Lightning impulse withstand voltage	kV	75	125	170
Rated current	A	630	630	630
Rated short time withstand current		20 kA/4 s	20 kA/4 s	12.5 kA/3 s
Rated making current	kA	50	50	31.5

# PVB-S pole-mounted vacuum circuit breaker

## 12 kV, 630 A, 25 kA

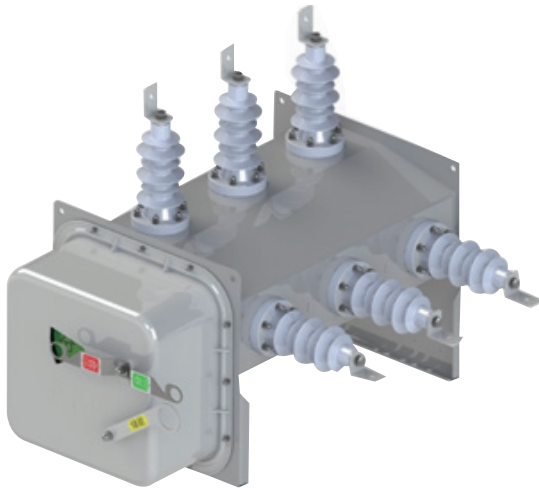

The PVB-S pole-mounted vacuum circuit breaker is a new type of pole-mounted switchgear in the ABB vacuum circuit breaker series. With the rated voltage of 12kV, it is suitable for the overhead line at the voltage level. Under the normal use conditions and within the technical parameters of the circuit breaker, the PVB-S pole-mounted vacuum circuit breaker can meet the operation requirements for the protection of the power grid in the running state, including the extremely excellent operating performance in the case of making and breaking short circuit current. The product meets the requirements of automatic reclosing, and shows the characteristics such as high operation reliability and long electrical service life.

- PVB-S pole-mounted vacuum circuit breaker is the perfect combination of ABB's well-known arc-extinguishing chamber and manufacturing technology as well as advanced operating mechanism, R&D, design and production technology
- Designed specifically for modern distribution automation systems
- Contacts in vacuum are protected from oxidation and pollution
- Spring operating mechanism, and standard configuration mechanical anti-trip device
- The current box is made of 3 mm high-quality ANSI 304 stainless steel, and processed by laser cutting, CNC bending and robot welding to ensure the high strength and sealing of the box
- Vacuum helium inspection process is used to ensure the tightness of each box. The annual leakage rate of SF6 is far lower than the requirements of relevant standards
- Low current ground fault solution - multi-frequency admittance ground protection
  - Groundbreaking application of the vector accumulation principle amplifies the fault characteristic signal to greatly improve the accuracy of fault judgment, and the fault judgment accuracy rate is as high as 99%
  - Ensure the accurate actuation of the faulty line and the reliable actuation failure of non-faulty lines

- Suitable for various power grids subject to neutral point grounding and various ground faults

### Technical parameters

Description	Unit	PVB-S
Rated voltage	kV	12
Power frequency withstand voltage	kV	42
Lightning impulse withstand voltage	kV	75
Rated current	A	630
Rated breaking capacity	kA	25
Rated short time withstand current		25 kA/4 s
Rated short-circuit making current (peak)	kA	63
Mechanical life	次	10000

# NCX and ICX drop-out fuses

## 12...24 kV, 100...200 A, 8...12.5 kA

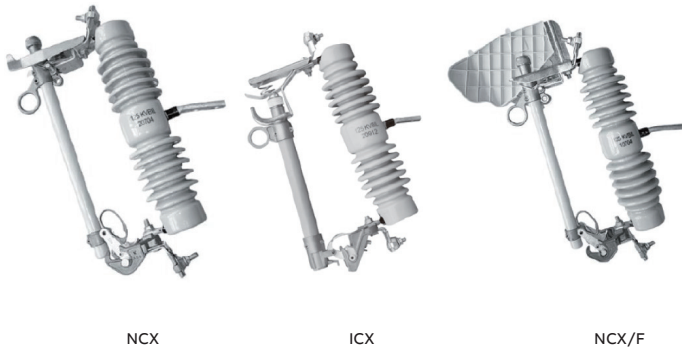

NCX

ICX

NCX/F

NCX and ICX drop-out fuse is used for short-circuit protection of 12 kV distribution line branches and the primary side of distribution transformers. With an obvious disconnection point, it is capable of disconnecting switch function.

In addition, the NCXF drop-out fuse is also equipped with an arc extinguishing grid, which can be used for switching operations of the equipment and is capable of load switch function.

It has the characteristics of flexible application, reliable quality, easy installation and long service life.

- Good short circuit breaking capacity. NCX/NCXF short circuit breaking capacity is 12.5 kA / 12 kV, and ICX short circuit breaking capacity is 8 kA / 12, 24 kV
- Single-end exhaust (ICX) and progressive double injection (NCX / NCXF) methods
- Waterproof and anti-fall design
- The fuse tube resistant to moisture and deformation and has a large breaking capacity, resistance to ultraviolet rays and a long service life; it has excellent electrical characteristics, insulation strength, mechanical rigidity and self-cleaning ability
- Alloy castings, excellent surface protection and high mechanical strength meet the requirements of use under severe environmental conditions
- The overall structure is good for neutrality and has good interchangeability

### Technical parameters

Description	Unit	NCX/NCXF	ICX
Rated voltage	kV	12	12/24
Power frequency withstand voltage	kV	42	42/65
Lightning impulse withstand voltage	kV	75	75/125
Rated current	A	100、200	100、200
Rated short-circuit breaking current	kA	12.5	8

# DCD pole-mounted disconnecting switch

## 12 kV...24 kV, 630...1250 A



The DCD pole-mounted disconnecting switch is a hook-rod operation switch. It is used for the isolation of 12 kV and 24 kV overhead lines. It is widely used in conjunction with circuit breakers or load switches to provide safe and visible breaks for the lines. The switch can be opened and closed without loads.

- **Base**  
The high-strength steel plate treated with hot-dip zinc anti-corrosion process can ensure reliable operation and anti-corrosion performance; square neck bolts are used with the square holes on the bottom plate to facilitate actual installation.
- **Post insulators**  
High-strength silicone rubber insulators with good hydrophobic properties, outdoor epoxy resin insulators, or ceramic insulators are used
- **Main circuit design (silicon rubber and epoxy resin products)**  
The symmetrical double static-contact design is used to make the DCD have double circuit conduction, and the rotating parts are fastened in the position of the non-main conductive circuit to ensure a low temperature rise under normal operating conditions. The overlapping parts of the main contacts are all treated with silver plating process to effectively enhance the conductive performance of the disconnecting switch.
- **Wiring terminal**  
The standard double-hole wiring copper bar is adopted, and the size and spacing of copper bar holes keep in line with domestic common habits to facilitate the installation by customers.
- **Disconnecting link limiting device (silicon rubber and epoxy resin products)**  
The device can enhance the stability of the

disconnecting link operation, and has two limit methods of 90° and 160°, which can be adjusted by themselves.

- **Operating pull ring**  
The lever design of the pull ring and the rotation locking pin can facilitate opening operation and improve the ice breaking ability.

### Technical parameters

Description	Unit	DCD			
Rated voltage	kV	12		24	
Power frequency withstand voltage	kV	42		65	
Lightning impulse withstand voltage	kV	75		125	
Rated current	A	630	1250	630	1000
Rated short time withstand current		20 kA/4 s	25 kA/4 s	20 kA/3 s	25 kA/4 s
Peak withstand current	kA	63	63	50	63
Insulator type		Ceramic, silicone rubber and epoxy resin		Silicon rubber	

# FSKII-C outdoor vacuum circuit breaker for railway

27.5 kV, ...2500 A, 31.5 kA



FSKII-C is a circuit breaker product specially designed for railways. It is used for 50 Hz 27.5 kV / 2x27.5 kV electrified railway substations and partitions. It is designed according to relevant international and domestic standards and has passed relevant type tests. It adopts vacuum arc extinguishing technology and reliable spring operating mechanism. It is a C2-E2-M2-S1 circuit breaker with extended mechanical life and electrical life. It is suitable for lines and cable systems and can withstand higher transient recovery voltage.

- Based on the continuous vacuum breaking technology of ABB, it has extended electrical life and extremely low restrike rate
- Simple and reliable spring operating mechanism can reduce operating power and guarantee the extended mechanical life
- Vacuum arc extinguishment is used to reduce the impact on the environment
- Electrical and mechanical anti-trip
- Porcelain insulator pole is suitable for outdoor severe environment
- Compliance with the requirements for automatic reclosing
- Simple installation - mounting bracket with adjustable or fixed height
- The circuit breaker body is assembled and tested at the factory to reduce on-site installation workload

## Technical parameters

Description	Unit	FSKII-C
Rated voltage	kV	27.5, 2X27.5
Power frequency withstand voltage (interphase/fracture)	kV	95/118
Lightning impulse withstand voltage	kV	185/215
Rated current	A	1250/1600/2000/2500
Rated short circuit breaking current	kA	31.5
Rated short time withstand current		31.5 kA/4 s
Rated short-circuit making current (peak)	kA	80
Mechanical life	Times	10000
Rated operating sequence		O-0.3 s-CO-180 s-CO

# ABB Electrification-Distribution Solutions Service

## Service Business

### ABB Electrification-Distribution solutions Service

ELDS Service, established in 2007, is the first in the industry to create a new business model based on providing services and solutions to customers. Based on ABB Group's leading technology and rich service experience, it is committed to providing users with life-cycle support services for power distribution systems and equipment of the users. Business types include 11 service categories such as Installation and commissioning, Training, Spare parts, Maintenance, Repairs, Engineering & Consulting, Advanced services, Extension, upgrades & retrofits, End of life service, Replacement and Service agreements of low and medium voltage distribution systems and equipment, to meet the needs of the users in the whole process from equipment installation, operation and maintenance to decommissioning.

Up to now, it has provided quality services and engineering solutions to more than 45 countries around the world, covering many customers in the electric power, industry, transportation and infrastructure. Its customer satisfaction is up to 97%.

### Service advantages

- Fast response - it took the lead in establishing a complete service network in China, and 26 local service centers close to customers have been built
- Original factory services - more than 400 engineers with original factory qualification implement the original factory standard
- Leading technology - ABB Ability™ intelligent technology based on data monitoring, acquisition, transmission, analysis, diagnosis and decision-making
- Customized service solution - tailor-made high-quality solutions to meet diverse customer needs
- 24-hour online services - 7 \* 24h 400-820-9696 customer service hotline for response
- Hundred-year service experience - it has more than one hundred years of experience in research and development, manufacturing, service and management of electrical equipment and systems

Beginning from  
2007



- The first business model based on service solutions provided to customers in the industry
- Taking the life cycle management of equipment as the core
- Tailor-made services and engineering solutions are provided
- Covering low and medium voltage distribution system equipment

More than  
>500  
employees.



- Main functions
- Field services
  - Design and development
  - Manufacturing
  - Quality control
  - Marketing

11 categories



- Services covering IT life cycle
- Installation and debugging
  - Maintenance and repair
  - Training and spare parts
  - Transformation and life extension
  - Intelligence and system solutions

Distribution  
system services



- Supporting multiple ABB factories
- ABB Xiamen Switchgear Co., Ltd.
  - ABB Tianjin Switchgear Co., Ltd.
  - ABB Beijing Switchgear Co., Ltd.
  - ABB Xiamen Low Voltage Equipment Co., Ltd.
  - ABB Xiamen Electrical Equipment Co., Ltd.

**Service categories**

Meeting the services required by the equipment throughout its life cycle

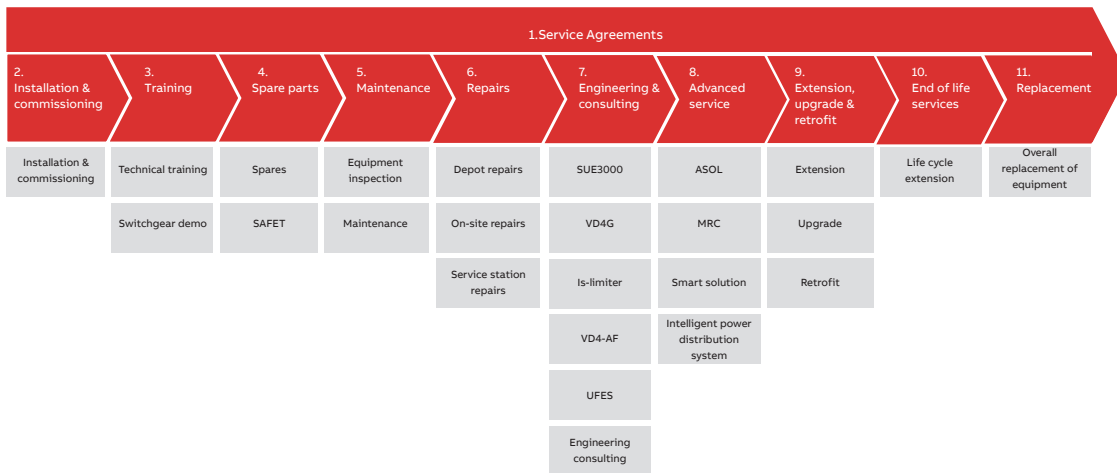

- Based on product life cycle
- Service agreements: long-term supply agreement based on business types across multiple services of product life cycle
- Upgrade: upgrade based on ABB products
- Retrofit: Retrofit based on third-party products
- Life cycle extension: services provided to extend the life of the equipment close to the economical service life

**Life cycle management of equipment**

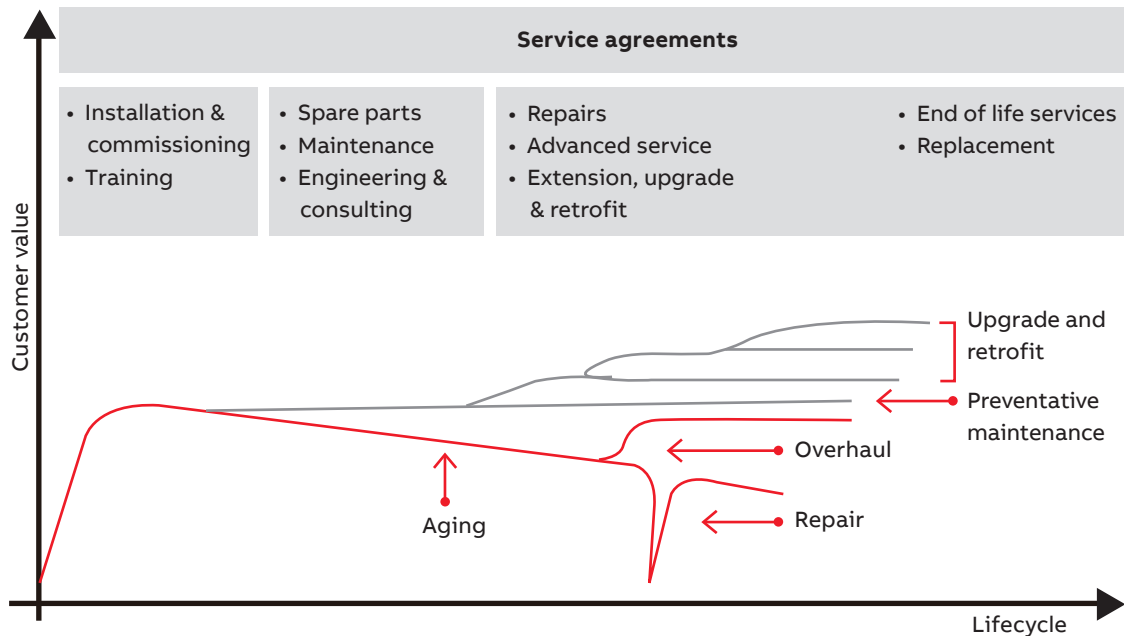

### Remote center

#### Intelligent diagnosis

Through the equipment health status management system, the remote center can obtain the health status of the switchgear at the first time, and give an early warning of bad trends. In addition, it provides professional optimization suggestions based on the historical information of the equipment information management platform.

#### Safety monitoring

Remote safety permit and operation process monitoring are used to review the personnel qualification, site environment, PPE and other items one by one, to ensure that all work is performed by engineers with original factory service qualifications to guarantee operation safety and delivery quality.

#### Technical supports

ABB's technical expert team keeps online in real time to provide powerful remote technical supports so as to solve on-site difficult problems of the customers through the remote management platform.

#### Satisfaction survey and service hotline

Execute and track customer satisfaction surveys, review and continuously improve delivery quality, and provide hotline consulting services.

## 26 service stations



# Business introduction: Service Agreements/ Installation and Commissioning /Training/ Maintenance

## Service agreement

The service agreement is for the service platform specially established by ABB for product users, which can ensure the stable operation of switchgear and systems in a more convenient way. ABB provides a wide range of service packages according to different conditions of the users, including assign customer service managers, spare parts support, product training, maintenance, product operation management planning, smart solution upgrade and retrofit, etc.. Through active and preventive services, the equipment can operate under safe and reliable conditions and always remain in an ideal operating state.

## Installation and commissioning

As the world's leading electrical equipment service provider, ABB relies on the original design concept of the equipment, strictly follows the technical construction requirements of the equipment itself and arranges professionally qualified engineers for field operation to ensure that the switchgear is put into operation in a safe, reliable and timely manner to meet the power supply demand. The equipment installation and debugging provided by Distribution System Service Center of ABB China include equipment installation guidance, debugging guidance and on-site operation training. The products under the services include air-insulated switchgear, gas-insulated switchgear, ring main unit, low-voltage switchgear, main switch, protection device, box transformer, etc.

## Training

Xiamen ABB University is the first distribution system training institution authorized by ABB University in North Asia. It is equipped with complete theoretical training and practical training facilities and has senior certified lecturers to provide the users with standard and customized power product training courses. It can help the users improve operation and maintenance skills, and can customize sustainable learning and development plans for enterprises and individuals according to their wishes.

## Course matrix:

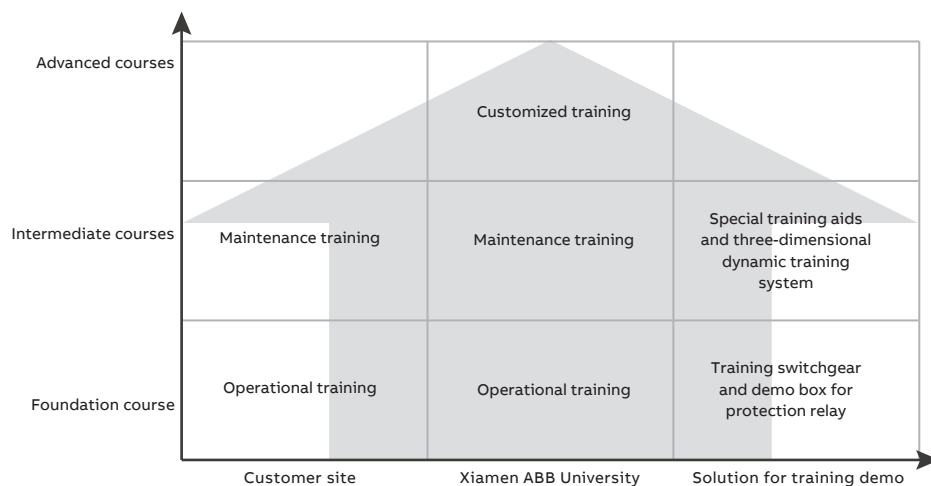

## Repairs

### Field repairs

ABB can provide on-site repair services for general defects that do not affect the operation of the equipment, to eliminate faults in a shorter time and restore equipment functions.

### Service station repairs and depot repairs

For the failures that affect the safe operation of the equipment or for the required special instruments and related tests, provide local service stations or depot repair services

# Business introduction: Spare parts/ Maintenance

## Spare parts

ABB can provide the users with spare parts support during the life cycle of the ABB products. We have set up storage warehouses of spare parts at major service stations across the country, which can provide fast spare parts business and ensure the timely supply of spare parts, thereby shortening the repair time and reducing the loss of the users due to downtime.

- Original spare parts are provided to guarantee the quality
- Precise spare parts are provided according to the original factory data to ensure that the spare parts are fully matched with the users' equipment

## Support range of spare parts

- Spare parts for low and medium-voltage air insulated switchgear
- Spare parts for gas insulated switchgear
- Spare parts for RMU
- Outdoor and circuit breaker
- Spare parts of circuit breaker and back-up circuit breaker
- Spare parts for relay protection and back-up relay protection
- Back-up current and voltage transformer

## Station equipment

The product can help customers improve the safety level of operations in substations, which is a one-step management plan for spare parts. The whole set of equipment includes spare parts boxes for commonly used materials, arc-proof equipment boxes for protecting personal safety, specialized tool boxes required for replacement of spare parts, and motor-driven lifting service truck.

## Motor-driven lifting service truck

- One-key operation, electric lifting, and direct landing of circuit breaker
- The width of the fork can be flexibly adjusted, and one can meet the landing needs of the main switch with a width of 325 to 1000 mm
- Suitable for ABB UniGear series of 24kV and below and similar local made switchgear

## Spare parts box, tool box and arc-proof box

- Based on the ABB spare parts database and operating procedures, provide accurate quantities and varieties of spare parts and tools; select arc protection equipment according to the safety regulations and provides the customer with personal protective equipment
- Military grade box: IP65, dustproof and waterproof, maximum load bearing of 90 kg, 3 m drop test



Motor-driven  
lifting service truck



Spare parts box



Arc proof box



Tool box



Spare parts box of MNS series low-voltage switchgear

Station equipment of medium-voltage switchgear

**Maintenance of MV switchgear**

With the increase of service life, the operating performance of MV switchgear will gradually decrease, so the equipment needs to be effectively managed to ensure safe, reliable, efficient and economical operation. According to the operation and management experience of ABB on the MV switchgear in the world, ABB divides the entire life cycle of the equipment into five stages: running-in period, stable period, attention period, decommissioning period and life extension period. Based on the whole life cycle management of the equipment and according to the characteristics of the switchgear in different operation stages, the equipment evaluation and maintenance program is well designed for equipment inspection, maintenance, in-depth maintenance and overhaul to significantly improve equipment performance and reduce operating costs during the life cycle of the equipment.

**Recommended maintenance cycle (take equipment operation cycle of 20 years as an example)**

Running stage	Run-in period			Stable period				Attention period				Decommissioning period		Life extension period								
Operating life	1	2	3	4	5	6	7	8	9	10	11	12	13	14	15	16	17	18	19	20	...	
Execution of detection		•		•			•			•			•			•	•		•		•	...

Note: The red part is recommended for in-depth maintenance.

**Recommended cycle of detection and maintenance for the circuit breaker operated frequently**

Rated breaking current of circuit breaker	25 kA	31.5 kA	40 kA and above
Maintenance cycle (number of operations)	4000	3000	2000

Note: For the switchgear with severe operating environment or frequent operation, the maintenance period shall be shortened appropriately.

**Intelligent maintenance management system**

To standardize maintenance standards and improve work efficiency, ABB has developed an intelligent maintenance management system based on handheld terminals. The software is developed based on the advanced terminal operating system and ABB online expert background, which can realize the real-time generation of equipment maintenance reports; it has more than 250 maintenance items to realize the programmatic operation and electronic management of maintenance work; in addition, the testing standards and delivery standards of the switchgear are built into the software, so that all the testing results are based on evidence and the number of tests can be traced back.



# Business introduction: Engineering & Consulting

## Engineering consulting

The engineering consulting plays a decisive role in the project investment and construction phase. ABB can provide professional engineering consultation, as well as the equipment and technical support services that improve system safety in the feasibility study, preliminary design, project execution and entire project process according to different needs of customers.

## High speed transfer system solution (SUE3000)

It can ensure uninterrupted power supply to prevent the auxiliary machine from stopping. The solution has the system response time of only 2 ms and low inrush current during the transfer, and it supports multiple methods such as high speed transfer and parallel transfer. The overall transfer time of the system does not exceed 100ms.

According to the special needs of the users, ABB can also provide an overall solution to shorten the transfer time to 30 ms.

## Product features

- High speed. When the action time is the sum of device response time ( $\leq 2$  ms) and inherent delay of circuit breaker, the no-current time is short and the fast transfer has little impact on system and high success rate
- High reliability. There are reliable operation records for more than 3,000 high speed transfer devices in the world
- Functional logic can be flexibly written to maximize the function of the device

## VD4G generator circuit breaker solution for small and medium power generator sets

A special generator circuit breaker is mounted at the outlet of small and medium-power generators to ensure that the short-circuit fault current of the generators can be safely broken to protect the generators and transformers, simplify the operation of the power plant and improve the availability of the generator, system safety, reliability, etc.. It is especially suitable for generator application of self-supply power plants, new energy power plants and small hydropower plants.

## Product features

- It can be used as an generator circuit breaker for small and medium-power generators with a capacity of 10~100 MVA
- It can quickly breaking the short-circuit current of the system-source and generator-source fault. The short-circuit current is up to 50 kA, and the DC component is up to 130%
- Interrupt the current by forcing it to zero when the fault current trend delayed current zeros
- Passing the test according to the latest generator circuit breaker dual logo standard IEC / IEEE 62271-37-013

## Active arc fault protection solution (UFES)

Scope of application: low and medium-voltage air insulated switchgear from 0.4 kV to 40.5 kV.

The active arc fault protection solution is a complete active arc fault protection system, which can quickly extinguish the fault arc within 4ms to significantly reduce the damage and impact of the high temperature and electric power arising from the arc accident in the power system. Compared with the only traditional arc monitor used for the system, ABB's active arc fault protection solution shows more obvious advantages in terms of operating time and reliability. The arc light and current used as the criteria can detect internal arc faults faster and quickly suppress the damage caused by the faults.

**Customer value**

- The fault arc is extinguished within 4 ms to significantly improve the safety of operation and maintenance personnel
- The service efficiency of the system is significantly improved
- Equipment outage time and maintenance costs are drastically reduced
- Release of arc-burning gas during arc fault is effectively limited



UFES truck application



Service box application

**Electric arc furnace power supply system solution (VD4-AF)**

The electric arc furnace power supply system solution is the perfect combination of ABB's new-generation servomotor actuation vacuum circuit breakers and motor-driven 3 position switch. Through the overall or partial upgrade of the existing operating system, the electric arc furnace system can operated safely and continuously to ensure continuous and reliable operation of key technological processes. This solution is especially suitable for the loads of electric arc furnaces in steel plants.

- The operating life is up to 150,000 times without overhaul to significantly reduce the life cycle cost of equipment
- Servo motor control system can accurately monitor each switching operation process to ensure the safe operation of the system

**Overall system upgrade**

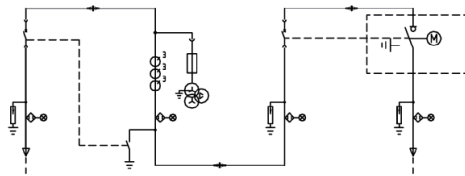

Typical system design (4 panels)

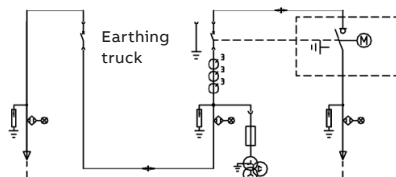

Typical system design (3 panels)

**Replacement existing switchgear**

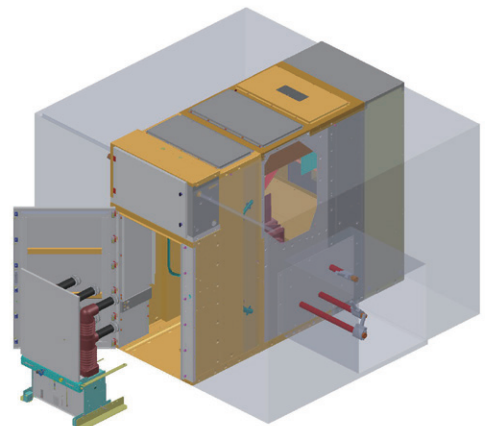

**Solution for impermissible short-circuit capacity (Is-limiter)**

It is an excellent solution to solve the problem of system short-circuit capacity exceeding the standard. It shows the characteristics such as high action speed, strong current limiting capability, compact structure, standardized design of external dimensions, indoor use and so on. The breaking time does not exceed 1ms, and the maximum breaking capacity can reach expected short circuit current of 210 kA.

**Features**

- The peak short-circuit current cannot be reached
- Quickly break the fault current to minimize the fault loss
- Standard design and uniform frame size
- Passing the type test in accordance with relevant standards
- Suitable for indoor environment

# Business introduction: Advanced Service

## Health management platform of ABB distribution equipment

Based on the online data of key switchgear healthy status, such as temperature rise, mechanical characteristics, etc., with the smart expert algorithm, the health management platform of ABB distribution equipment can perform diagnostic evaluation, online analysis of switchgear risk and predict failure probability. Thanks to the overall health index of the switchgear, we can provide customers with an executable operation and maintenance strategy advices. It can greatly improve the intelligent diagnosis and analysis capabilities of big data for operation inspection, raise the operation and maintenance efficiency, and optimize the operation and maintenance cost. It helps customers to transform passive prevention to active prediction, and realize predictive maintenance.

### 01 Introduction to cloud solution

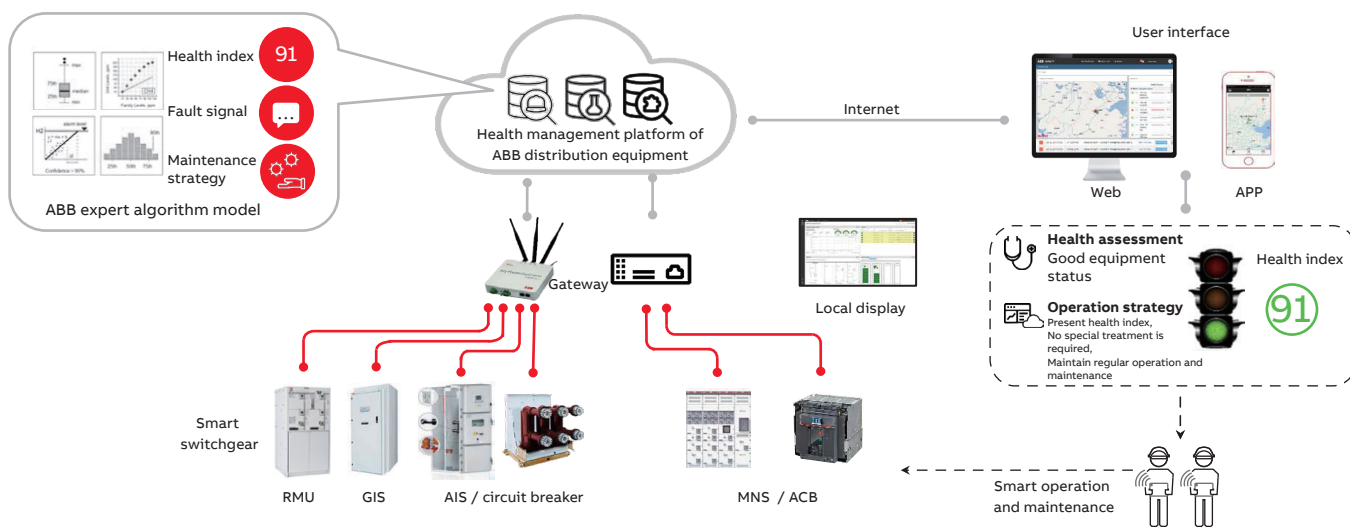

### 02 Introduction to local solution

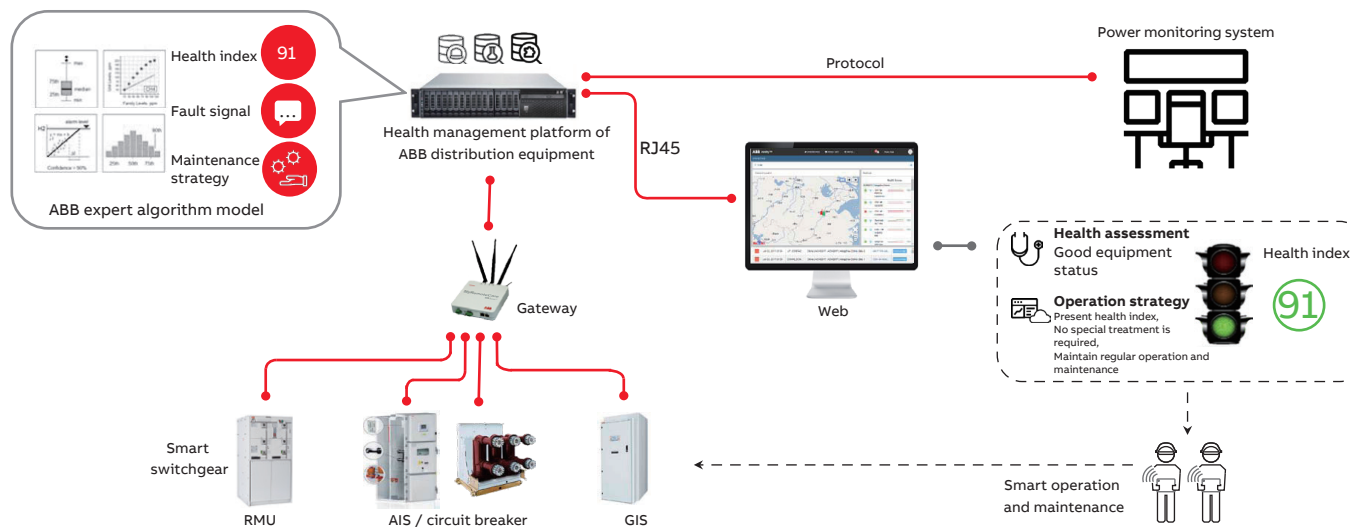

03 Overview of cloud interconnection solution

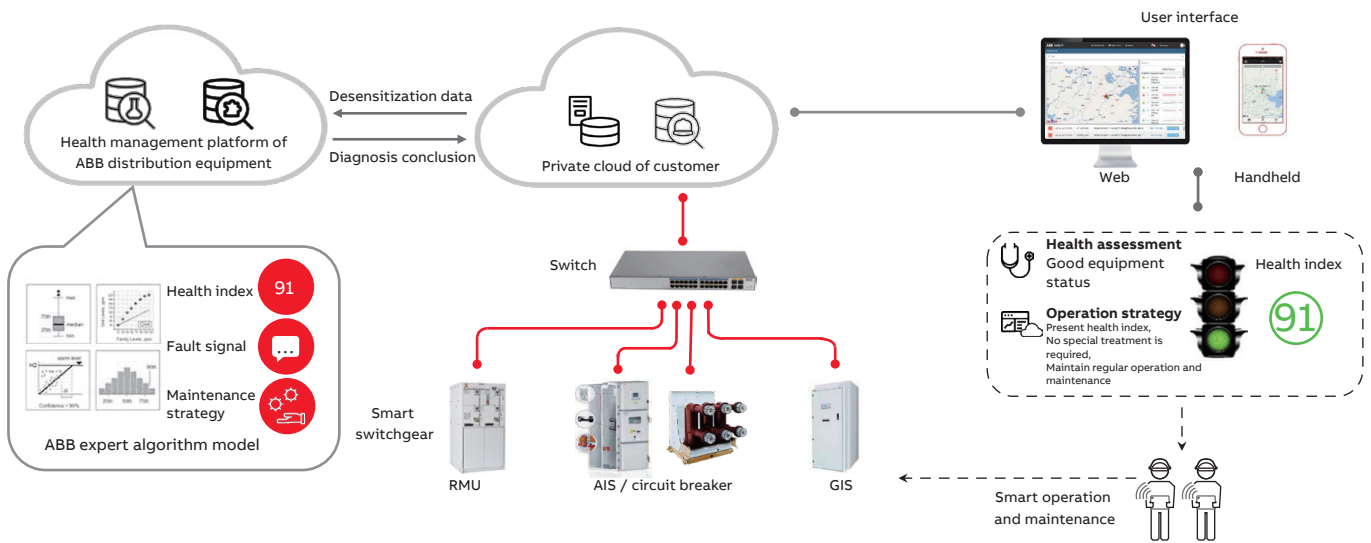

Mobile operation and maintenance platform



Based on switchgear parameters collected by the healthy management platform of ABB power distribution equipment, through the ABB cloud interconnection, it can transfer the operation status, healthy alarm and other information of the switchgear to the mobile operation and maintenance cloud platform database to achieve the display of equipment operation status and health information, and realize the creation and management of work orders for on-site operation and maintenance personnel. Based on summary statistics of equipment account, operation, health data and other information, it can greatly improve the operation and maintenance efficiency and operation safety.

ABB mobile operation and maintenance functions include: equipment operation and healthy alarm management, work order management, data statistics, equipment asset account management, etc..

**Intelligent solution for air-insulated switchgear**

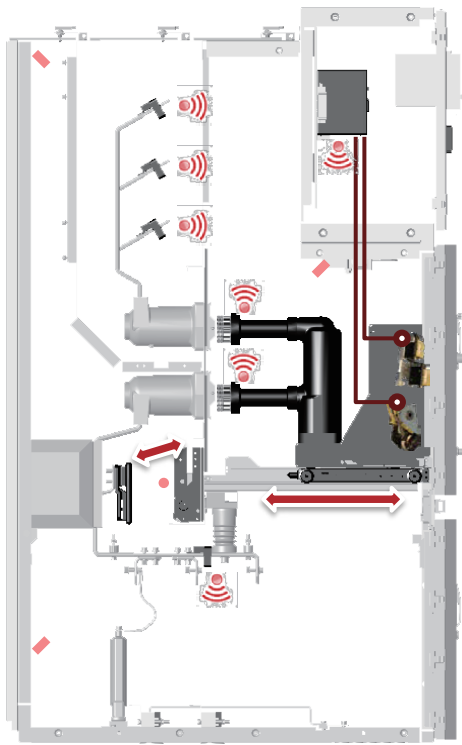

Sensor type	Monitoring function	Diagnosis function
Wireless temperature sensor	Key point temperature monitoring - Contacts / busbars / cable heads - Low-voltage chamber	Temperature rise threshold diagnosis
Smart current sensor	Primary current monitoring - Three-phase load current - Three-phase breaking current	Dynamic temperature rise diagnosis based on real-time load
tHall type voltage / current sensor	secondary component monitoring - Charging motor waveform/time - Closing and opening coil waveform - Status of auxiliary contacts	Residual electrical life diagnosis of vacuum arc-extinguishing chamber
Contact pressure sensor	Mechanical characteristics monitoring - Opening and closing time / speed / overshoot - Contact clearance * / overtravel * / rebound amplitude * - Contact working pressure *	Condition monitoring of secondary component
Main shaft angle sensor	HD4 pole SF <sub>6</sub> monitoring - Temperature / pressure / 20 °C pressure / density	Diagnosis of mechanical properties
HD4 SF <sub>6</sub> gas density sensor	Visual monitoring - Open shutter earthing switch / busbar / cable	Gas state diagnosis of HD4 pole
Camera	Programmatic operation - Control and protection of truck motor drive - Control and protection of earthing switch motor drive	Visual diagnosis

\* Only EL institutions are supported

The smart solution of the air-insulated switchgear is adopted to perform full or custom upgrades for key parts of switchgear cabinet and circuit breaker in the existing substation, so as to realize the online monitoring of dynamic temperature rise diagnosis of the switchgear based on the real-time load, residual electrical life of the vacuum arc-extinguishing chamber for circuit breaker, the state of secondary components and mechanical characteristics, and the programmed operation of the circuit breaker truck and earthing switch.

**Visual monitoring**

It can realize the visual monitoring of the switch status in the switchgear (applicable to the centrally installed switchgear and ring main unit). The camera based on the transmission of digital video signals is used to realize the visual management of the circuit breaker truck, truck switch position and the cable compartment, precisely capture the switch status, remotely transmit and record video. It is an effective tool to ensure the safety of equipment and personnel, and to assist in confirming the real-time status of equipment.

**Smart solution of ring main unit**

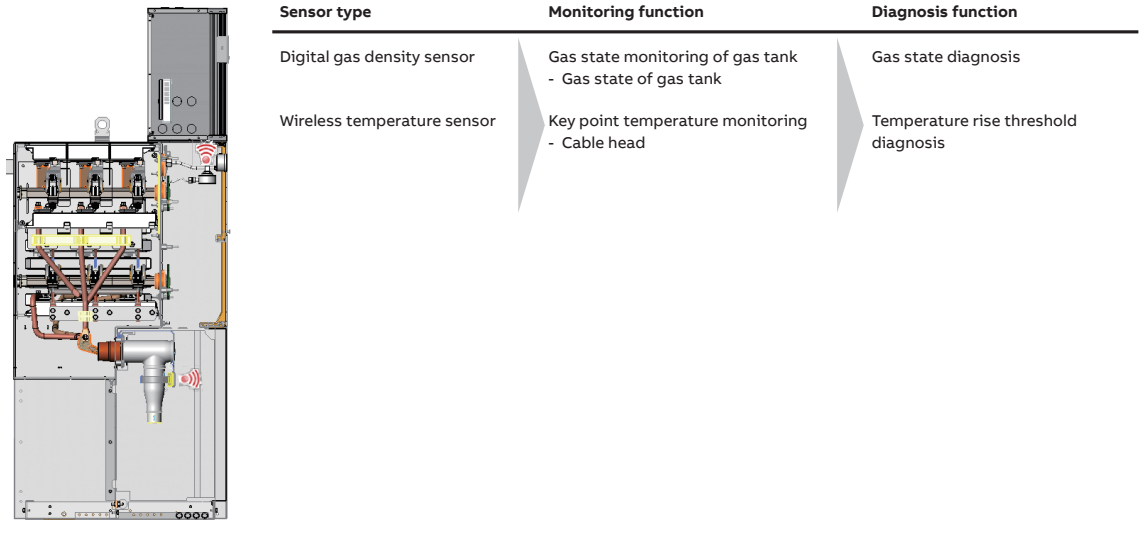

The smart solution of ring main unit is integrated with real-time temperature monitoring, real-time pressure monitoring, local acquisition and diagnosis, and cloud diagnosis. Through the deployment of sensors in the cable head and the gas tank, the condition monitoring is performed for the real-time temperature of the cable head and the gas density in the gas tank. In addition, the smart monitoring unit mounted in the low-voltage compartment can diagnose abnormal temperature and pressure signals on site, and can realize remote monitoring and cloud diagnosis through the mobile phone APP or MRC gateway.

**Intelligent solution of gas insulated switchgear**

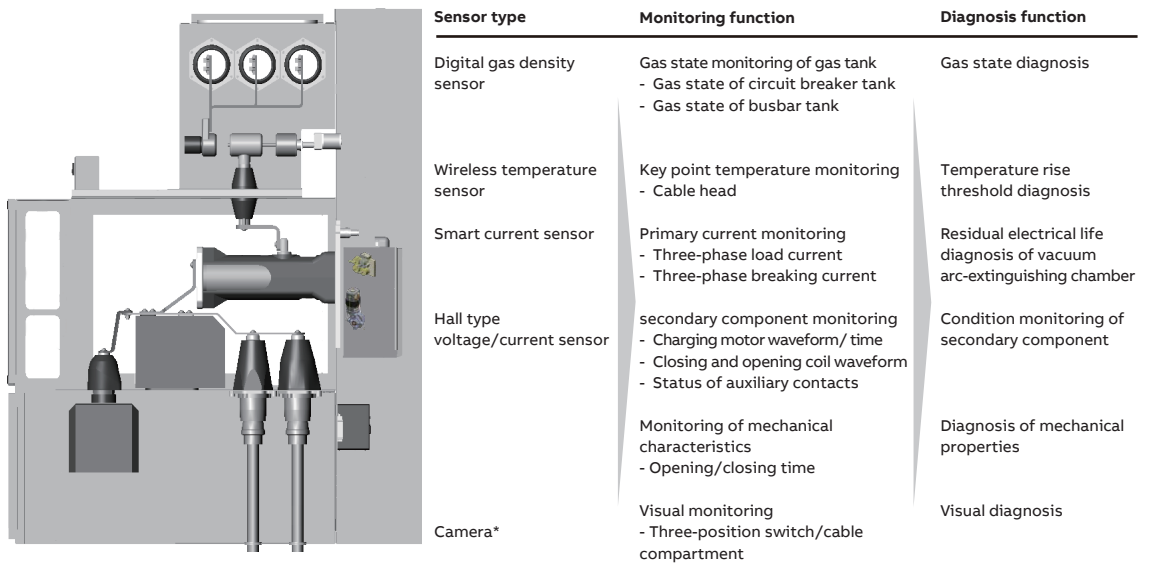

\* Only the new ZX2 cabinet is supported

The smart solution of gas insulated switchgear enables the intelligent transformation of traditional gas insulated switch equipment. It is integrated with the functions such as real-time monitoring of gas density in the gas tank and circuit breaker parameters. It is a remote condition monitoring system that supports the implementation of condition based maintenance, and it has become the most advanced intelligent transformation scheme in the field of medium-voltage switches.

**Digital solution of MNS low-voltage switchgear**

Sensors and smart meters	Monitoring function	Diagnosis function
Wireless temperature sensor	Copper bar temperature	Overtemperature alarm Running time
Infrared sensor	Temperature of primary power contact	Insertion cycles Downtime
Feeder controller	Measurement & monitoring - Current, voltage (actual value, average value, maximum value and unbalance) - Frequency - Active power / reactive power / apparent power (actual value, average value and maximum value) - Temperature value - Active energy - Reactive energy - Apparent energy - Fault signal - Main switch on/off signal	SOE for 256 events with time stamp

By implementing internet technology and the deployment of smart sensors, ABB's innovative digital solution for low-voltage switchgear makes the traditional switchgear advance with the times and become a member of the intelligent Internet of Things. It can be widely used for industries, infrastructure, rail transit, smart buildings and other fields to provide the users with digital solutions and services so as to ensure safer and more reliable power supply.

**Service solution**

- Busbar temperature on-line monitoring: self-powered wireless temperature measurement technology, flexible and convenient for application and installation
- Temperature on-line monitoring of switchgear module: special temperature measurement technology for switchgear integration, non-contact, no additional insulation needed, safer and more reliable; sensors fix to the power contact housing, for easy maintenance.

**Features**

- Using the self-powered technology
- The upgrade solution is mature and reliable, and can be flexibly configured
- TCP/IP communication for easier and flexible system integration

### Power monitoring system ESD3000

The power monitoring system ESD3000 is used for high-voltage switchgear, medium-voltage switchgear, transformer and user terminal of the substation at 110 kV and below. It effectively improve the stability and reliability of power system operation and raise the efficiency and quality of industrial production and operation. It is an important part of industrial production informatization and automation management. The ESD3000 power monitoring system is capable of an open communication management function. It can be compatible with various ABB intelligent devices and other manufacturers' intelligent products with standard communication protocols, and can provide a standard interface to connect with external computer systems.

### Features

- Real-time monitoring, accident pre-alarm, and automatic generation of various reports, curves and graphs
- Statistics, analysis and management of building energy consumption to improve energy efficiency and reduce energy waste
- Equipment management functions such as equipment ledger, spare parts management, maintenance records, maintenance reminders, etc.

### Customer value

- Improve management efficiency and reduce maintenance costs
- Improve grid quality and reliability of power supply
- Internet of Things technology to provide new ideas for power management and control
- Help users understand the energy flow and improve energy management in the building area



# Business Introduction: Extension, Upgrade & Retrofit

## MV system capacity extension

It can provide rich capacity increase and extension solutions for the MV switchgear in operation. According to different site conditions and customer requirements, it adopts tailor-made and professional design to meet the needs of customers for increasing the number of circuits, rated current and short-circuit current of the equipment.

## Extension solution for MNS series LV switchgear

Since the MNS® series switchgear was launched, more than 1.5 million sets of MNS® switchgear have been delivered worldwide. With a large amount of overall project operation experience, ABB can provide a full range of services such as solution evaluation, measurement, design, non-standard customization of cabinet, installation and debugging, and assist the power supply system to achieve effective and rapid extension and upgrade.

ABB can provide a series of supplementary overall solutions for low-voltage cabinets, to connect the old cabinets and the MNS cabinets through the transfer cabinet or direct busbar connection.

## Customer value

- Mature extension solution for non-ABB cabinets and rich industry application experience
- Provide measurement, solution design, installation and debugging and long-term after-sales services
- Mature transfer cabinet and direct connection solution
- Provide long-term spare parts and after-sales service supports
- Provide leading low-voltage switchgear and module technology
- Effectively respond to system extension needs and improve safety and reliability of the overall system

## Upgrade solution for distribution network switchgear

In order to ensure the stable and efficient operation of distribution network equipment and meet the national deployment of upgrading the distribution network and promoting smart grid construction, distribution system service of ABB China specifically launched an upgrade solution for distribution network switchgear. By upgrading the original switchgear gas pressure meter, manual operation change to electric operation, passive power change to active power, low-voltage cabinet upgrade and DTU, the solution adopts the original core components of ABB to help the users realize the remote signaling, remote metering and remote control functions required by the distribution network automation so as to keep the distribution network equipment always in a safe, reliable and efficient ideal operating state.

Scope of application: SafeRing / SafePlus / UniSwitch

## Customer value

- The original equipment that has passed the test and certification can meet the requirements for long-term reliable operation
- Minimal power outage time and short on-site replacement time
- Long-term and stable spare parts supply and service support
- Less life cycle maintenance cost of equipment
- Effectively reduce equipment failure rate and ensure the safety of operating personnel

## Relay upgrade solution

Relying on global technical capabilities and application experience, distribution system services can provide flexible and comprehensive relay upgrade solutions to help the users solve the problems encountered in practical applications. With advanced distribution automation concepts and technologies, it can help the users quickly improve substation intelligence to meet the requirements for smart distribution networks.

### Alternative solution for relay upgrade

Software and hardware upgrade of protection relay.

### Complete alternative

- Completely replace old equipment or malfunctioning equipment with new relay. Function extension also can be performed.

### Circuit breaker retrofit solution (OneFit)

The circuit breaker is the core component of the MV switchgear, and its reliability and safety are the basis for the stable operation of the entire power system.

ABB circuit breaker transformation solution takes VD4 circuit breaker and other main switches of ABB as the transformation platform to tailor various types of circuit breakers to fit the original cabinet through professional design on the basis of retaining the original cabinet and civil construction. The transformation solution is compatible with many types of switchgear, and can meet the requirements of improving the overall safety and reliability of the system, extending the life of the equipment, and upgrading intelligence at a low investment cost.

Up to now, ABB has owned the transformation experience for more than 3,500 circuit breakers, and has provided circuit breaker solutions for 23 types of international and domestic switchgear. The industry applications cover the electric power, industry, transportation and infrastructure, etc..

### Challenges

- Technology iteration, electric field distortion, and eddy current heating
- Old, insulation aging, mechanism jamming and frequent failure
- Difficult supply of spare parts, affecting equipment maintenance
- Complex operation and low operating efficiency
- Failure to meet the requirements for five-prevention, IAC and state grid countermeasures, etc.
- No electric operation, online monitoring, etc.

### Retrofit solution

- Direct replacement of circuit breaker
- Switchgear room transfer solution
- Overall transplantation of switchgear room

### Direct replacement of circuit breaker

- Applicable to the transformation of center-mounted circuit breakers and contactors
- Full upgrade of the original electrical and mechanical interlocks
- The solution is mature and reliable, with strong adaptability and small amount of transformation

### Customer value

- Comprehensively improve the safety and reliability of equipment and systems
- Significantly improve operation and running efficiency
- Effectively reduce investment costs by 50%
- Reduce construction power outage time by 90%



**Switchgear room transfer solution**

- Through the professionally designed contact transfer system, the original static contacts of switchgear are perfectly connected with VD4 moving contacts to maintain the spacing of VD4 standard round contact
- It can be flexibly adapted to various domestic cabinets, especially suitable for the cabinet with deep circuit breaker room or that with the static contact which cannot be removed
- Convenient installation, transformation time <8H / set, and short power outage time
- Perfect five-prevention interlocking, and passing a full set of tests



Before transformation



In transformation



After transformation

**Overall transplantation of switchgear room**

It is suitable for the transformation of fixed and floor-mounted circuit breakers for 10 kV domestic old switchgear.

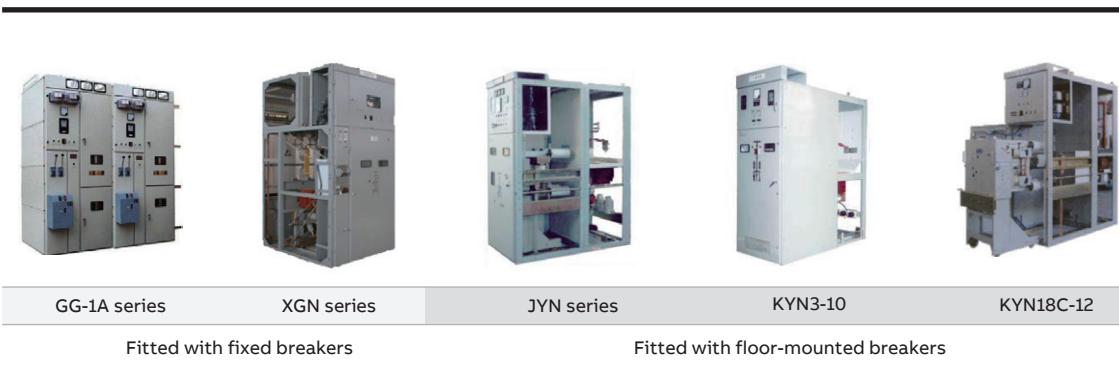

- Integrated with specially designed VD4 operating system, high operating efficiency, easy to maintain
- Spare parts supply in the life cycle
- Perfect five-prevention interlocking, and passing a full set of tests
- Optional functional solutions, such as grounding switch, CT, electric operation, online monitoring, etc.
- Short power outage

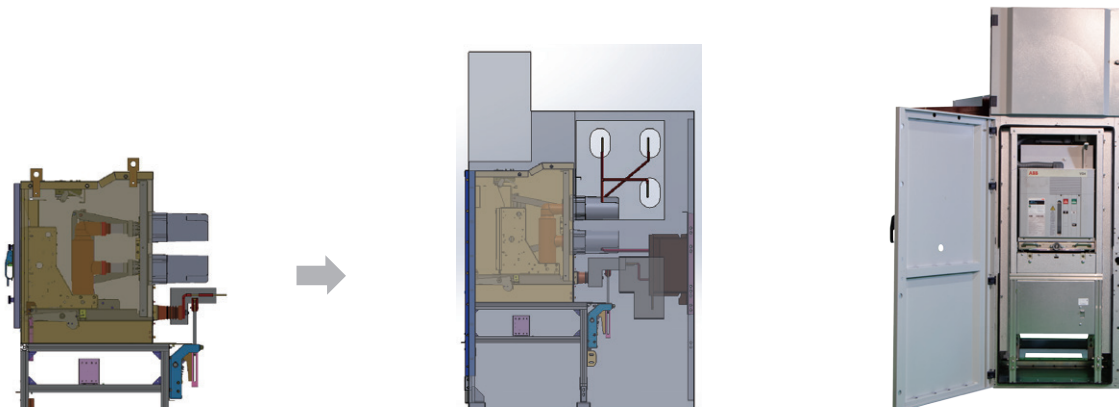

# Business Introduction: End of life Services / Replacement

## End of Life Services

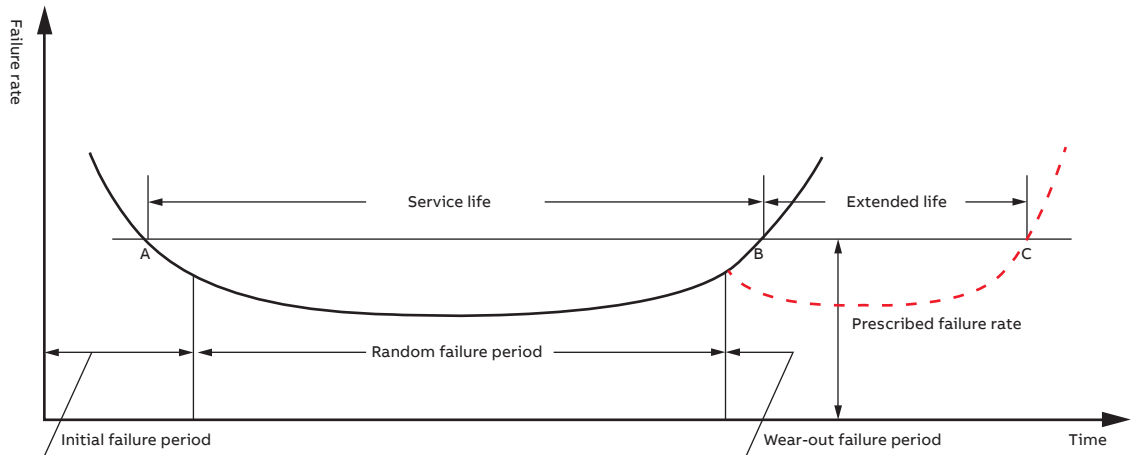

### Life extension service

- Extend equipment life to 30 years
- Save the investment costs by 30% to 70%
- Reduce the construction period by 60%

### Life extension solution

- Life extension of switchgear
  - VD4 vacuum circuit breaker
  - HD4 SF<sub>6</sub> circuit breaker
  - Low-voltage air circuit breaker
- Life extension of protection relay
  - SPACOM series protection relay
  - INSUM motor protection relay

### Replacement

For the equipment with performance aging or close to the decommissioning period, ABB, based on rich operating experience, provide the customers with customized value-added services and overall solutions to improve the life-cycle operating performance of the equipment.



---

**ABB Xiamen Switchgear Co., Ltd.**

No.885, FangShanXiEr Road, Xiang'an District,  
Xiamen, Fujian, 361101  
Fax: 0592 603 0505

**ABB China Customer Service Hot Line**

TEL: 800-820-9696 / 400-820-9696  
mail: cn-ep-hotline@abb.com

**[www.abb.com](http://www.abb.com)**