

# Photometer applications in a maleic anhydride process

## PIR3502 Multiwave process photometer



Increase the efficiency of the maleic anhydride process.

**Measurement made easy**

PIR3502  
IR process photometer

### Industry

Chemical

#### Introduction

Maleic anhydride is a reactive reagent that is used to make unsaturated polyester and alkyd resins, plasticizers and dicarboxylic acids. Polyester resins are used in the fabrication of fiberglass reinforced parts. Alkyd resins are used in the coatings industry. Maleic anhydride is also used in the manufacture of agricultural chemicals. A synthesis route commonly used to make maleic anhydride is the catalytic oxidation of butane. ABB's PIR3502 infrared (IR) process photometers can measure key components in the maleic anhydride process. The continuous analysis provided by the photometers allows for closed loop control of this process. The use of photometers to monitor this reaction provides improved efficiency and safety in the maleic anhydride process.

#### The analyzer

The ABB PIR3502 IR process photometer is a multiple channel fixed wavelength photometer that can accommodate up to eight different optical filters on its filter wheel. It works by ratioing the energy from a measure wavelength filter (where the component of interest absorbs energy) to a reference wavelength filter (where none of the components absorbs energy). The photometers used to measure the key components in the maleic anhydride process utilize optical filters in the IR region of the electromagnetic spectrum. The calibration of the photometer uses a matrix algorithm that allows for multicomponent analysis on the reactor effluent stream. This photometer has established an excellent reputation for reliable and stable performance in maleic anhydride plants.

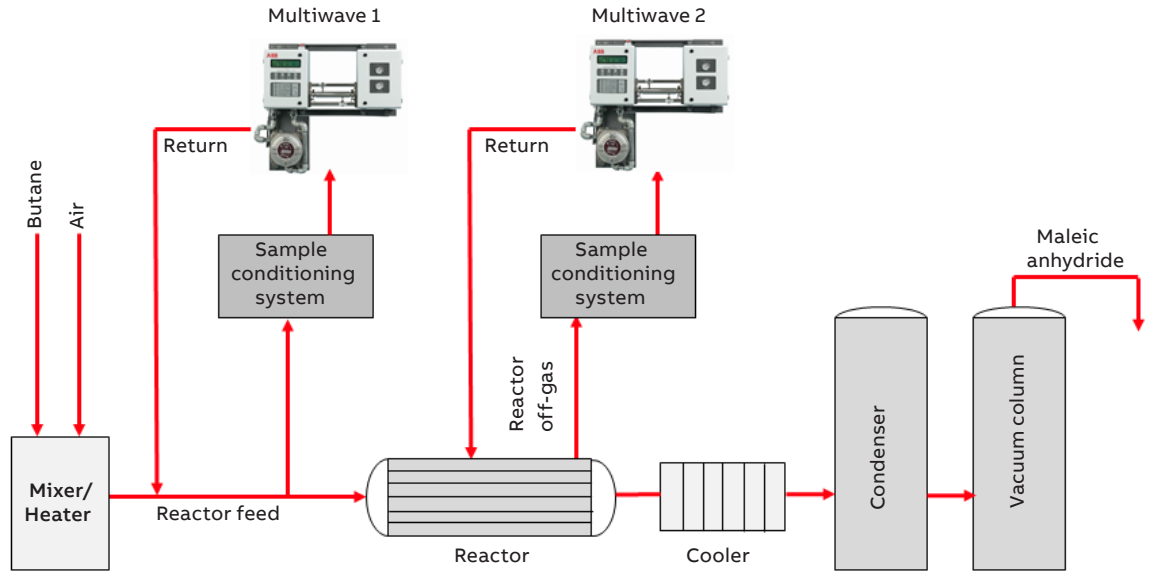

### Discussion

A common synthesis route for the manufacture of maleic anhydride is the catalytic oxidation of butane. A schematic of a typical maleic anhydride plant is shown above. There are two important photometer measurement locations for controlling the maleic anhydride process:

#### 1. Reactor feed

The first step in the maleic anhydride process is to mix butane with air in the mixer / heater which is then fed to the reactor. In the butane / air mix it is necessary to measure the butane and the water vapor. The measurement of the butane is important for two reasons:

- Safety – to safely operate the plant it requires that the butane concentration does not exceed the Lower Explosion Limit (LEL) in the reactor feed.
- Process yield – to optimize the yield it requires running the butane concentration as close to the LEL as possible.

The PIR3502 process photometer provides a fast continuous measurement of the butane concentration which allows for a quick control response to a change in the butane concentration and operation closer to the LEL. A second measurement on the feed is the water vapor content. This measurement is used for optimizing the reactor. The typical PIR3502 photometer on the feed stream is normally configured for the following measurements:

- butane 0 to 2 %
- water vapor 0 to 5 %

#### 2. Reactor off-gas

There are two sample handling approaches for making measurements for the reactor off-gasses. One approach is to use a water scrubber to remove the maleic anhydride from the stream and then only measure the butane, carbon monoxide, and carbon dioxide. The other approach is to keep the sample hot enough 175 to 200 °C (347 to 392 °F) to analyze the stream without removing any components. This approach also allows for the maleic anhydride to be measured. The PIR3502 Multiwave photometer is available with a heated sample cell to make the measurement without having to remove the maleic anhydride. The following multicomponent analyses can be measured on one PIR3502 photometer in the reactor off-gas in the non-scrubber sample system:

- maleic anhydride 0 to 2 %
- butane 0 to 1 %
- carbon dioxide 0 to 2 %
- carbon monoxide 0 to 2 %

### Conclusion

The PIR3502 IR process photometer increases the efficiency of the maleic anhydride process. The fast response time of the photometer allows for quick remedial action when the composition of the measured component is off spec. The continuous measurement of butane in the reactor feed ensures safe operation of this process.