

# Hoist and haul

ABB delivers a unique hoisting system for a marine railway

Klaus Kacy

Boating along the waterways of Canada, few people think of ABB or of mine hoists. Even fewer are aware that it is this technology that is making their trip possible.

The Trent-Severn Waterway is a 386 km long waterway through Central Ontario between Lake Ontario and

Georgian Bay. Its main purpose is recreational. A boat traveling along this route passes through a system of 44 locks. The Big Chute Marine Railway (BCMR) is one of these.

The implementation of the hoist was complicated by the variable incline, which changes from plus 20 percent

to level and then to minus 20 percent – a transition the payload is expected to make without a jolt (wine glass test). ABB has risen to this challenge by adapting a hoisting system using equipment otherwise used in mining hoists, and adding a number of novel features.

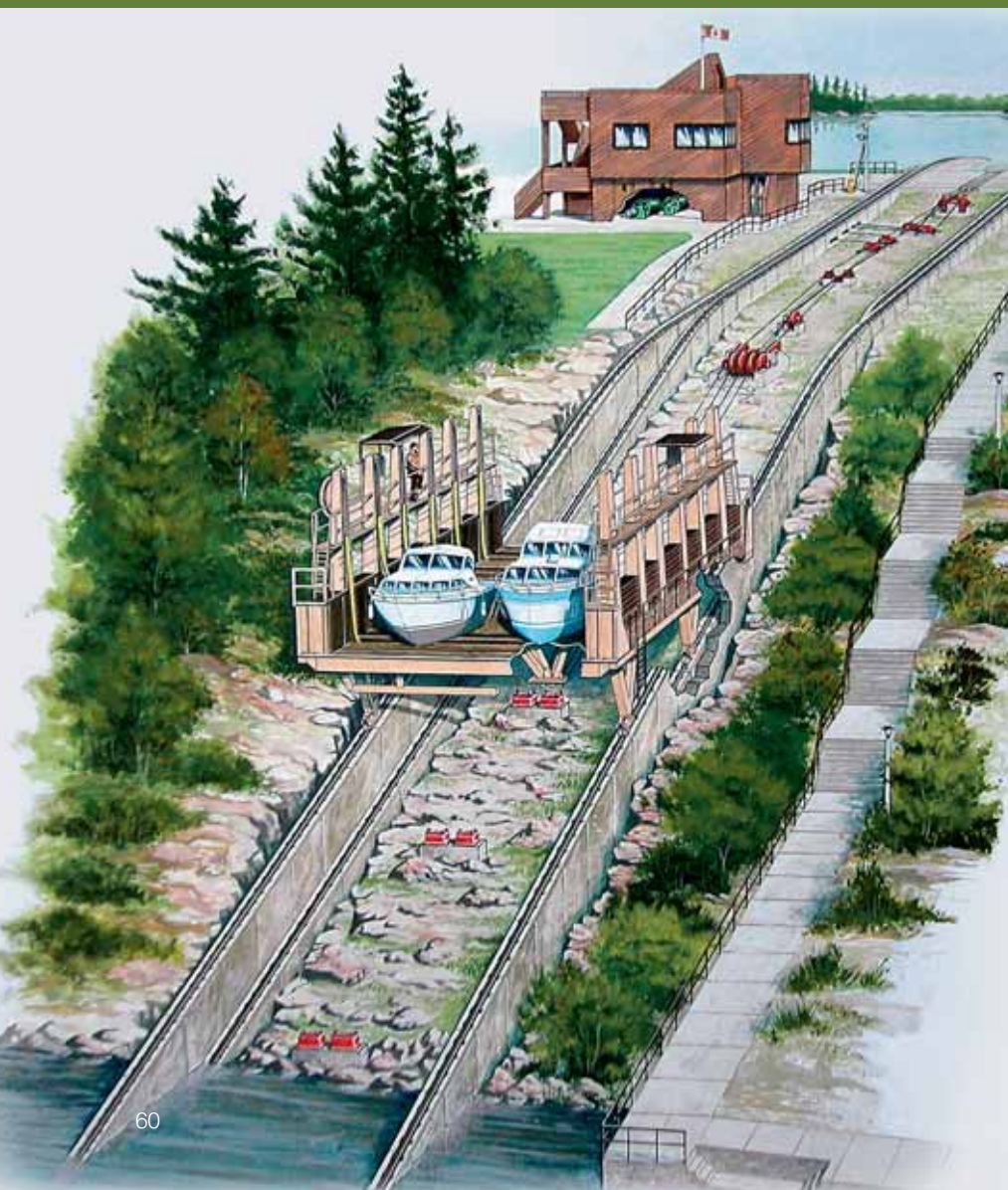

The Trent-Severn Waterway is a National Historic Site of Canada operated by the Parks Canada Agency. It is important to all Canadians as a symbol of their human heritage and identity.

The Big Chute Marine Railway (BCMR) is part of this waterway. Boats with passengers wanting to pass through the site are floated onto a partially submerged conveyance where they are cradled by slings. This conveyance runs on an inclined railway taking the boats out of the water, over an incline and back into the water on the other side **1**. The whole process takes on average about 15 minutes. The operators of the hoist travel on the conveyance and control it using a two-way radio system. Because the people on the boats and on the conveyance are traveling in a horizontal direction and, for the most part standing, the smoothness of the trip is important.

The original BCMR system experienced operational problems and after several incidents, the Parks Canada Agency decided to replace it with a more reliable, safe and robust system based on mine-hoist technology. ABB was awarded a contract for a new system with four single-drum hoists, in-

cluding all necessary electrical equipment and engineering. The conditions of this contract were challenging. Only six months were allowed for delivery (including commissioning) and the warranty period was set to five years. Taking into account the unique character of the system and scope of the work (which included extensive civil engineering work within the hoist house), finalizing the order within the set time was a remarkable achievement.

### Rope runs

The BCMR employs elaborate rope runs **2**. There are four single drum hoists **1**, two on the east side (E1 and E2) and two on the west side (W1 and W2). The ropes from the east side hoists run via horizontal sheave wheels (S1 and S2) towards the vertical set of sheaves forming the east transition point **a**, from where they run to the hauling plate below the conveyance **b**. Likewise, the ropes from the west side hoists run via the west transition point **f** to the conveyance.

In the situation shown in **2**, the hauling plate is between the two transition points **e** and **f**. In this situation, the ropes are attached to the plate from either side **4**. Beyond these transition points, however, all ropes attach from the same side **3**.

### New hoisting system for BCMR

The configuration of the track and arrangement of the rope runs requires different modes of operation of the hoist drives, depending on the direction of run and position of the conveyance. When travelling from east to west (left to right in **1**) the hoist drives operate as follows:

Between the east end **d** and east transfer point **a**, all four hoists are pulling the load (all are in motor

**1** The railway and its hoist house **a** rail tracks **b** boat conveyance **c** control panel mounted on conveyance, **d** east end of railway **e** east transition point **f** west transition point **g** west end **h** hoist house **i** four single-drum hoists **j** brake-control unit **k** control pulpit, **l** hoist control cubicle with local control panel, **m** DC-drive system, **n** "electronic lilly"

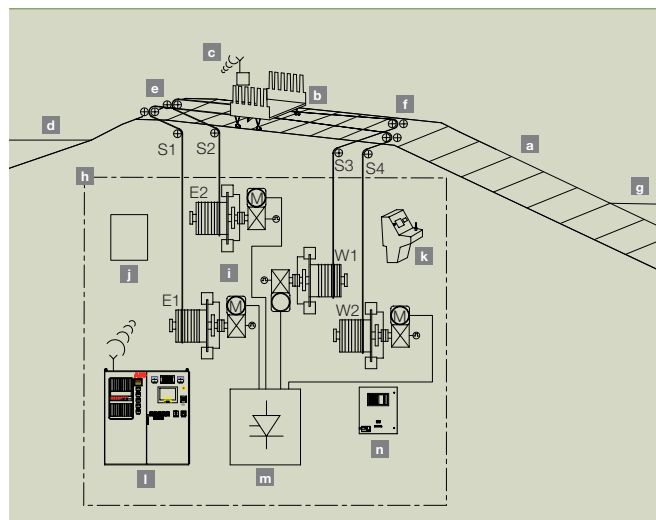

**2** The rope runs of the marine railway. The ropes change direction as the conveyance passes the sheave wheels (S1-S4)

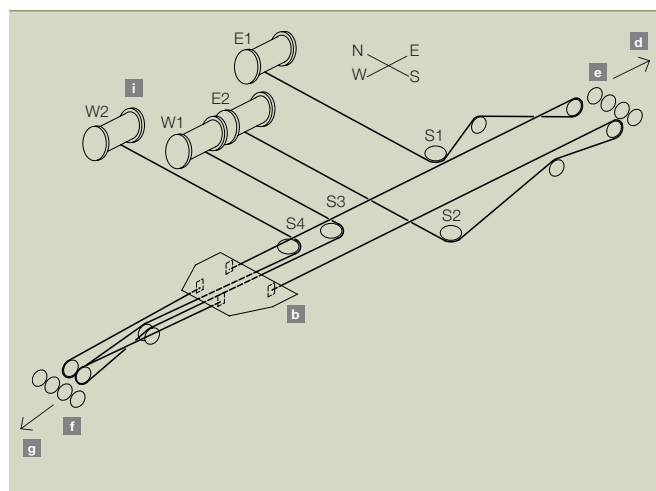

**3** In **2**, ropes are shown attached to the conveyance from both directions. After passing the transfer point **f** however, all ropes run in the same direction

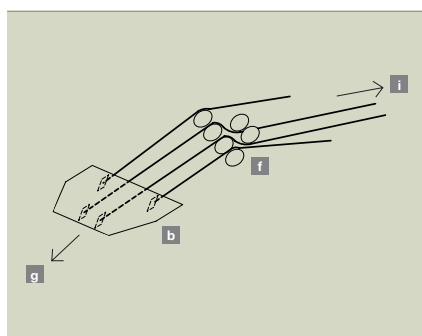

mode). On the section between the transition points **e** and **f**, the conveyance is running downhill and hoists E1 and E2 are in braking (regenerating) mode. In order to keep the ropes of the hoists W1 and W2 tensioned, both these hoists must provide pooling torque. They therefore operate in motor mode. The total rope force seen by the conveyance is the difference of the braking force from hoists E1 and E2 and the pulling force from hoists W1 and W2.

When the conveyance is between the west transition point **f** and the west end of the track **h**, all four hoists are holding the descending load (regenerating mode).

In the opposite direction, similar transitions in operational modes are necessary.

A distinct feature of the system is the reversal of the speed of one pair of hoists when the transition point is passed. For example when the conveyance is passing the east transition point **e**, hoists W1 and W2 maintain their speed equal to the conveyance speed, whereas hoists E1 and E2 slow down, stop and reverse their direction (switching from winding to unwinding).

The requirements on the hoist control, drive and braking system are discussed in the **Factbox**.

### A tour of the system

#### Hoists

The system has four single-drum hoists **5**, each with a 2.14 m drum. The drum shell has spiral grooves for the 32 mm rope. Each hoist has four high pressure brake units - two on each side - acting on the same disc. The hoist drum is driven by a DC motor through a gearbox. Due to space restrictions, the motors are mounted

## Ingenuity on the move



vertically. The relatively small size of the hoist room is dictated by environmental requirements for the whole hoist house (it is located in the regional park and its external appearance and size may not have industrial character).

### Brake control

The brake control system consists of two independent units, each equipped with an emergency brake regulator providing gentle but effective deceleration under all load conditions. In an emergency stop situation, it must handle several scenarios of braking torque distribution between the hoists. This is achieved by differentiating the brake pressure between the two control systems and also by delayed application of the brake units for the hoists when in “pulling” mode.

The hydraulic part of the brake control systems <sup>6</sup> are standard ABB dual hydraulic stations, as used for mine hoists. They are stand-alone units with two pumps (one running, one on stand-by), an oil tank, oil conditioning components and valves pro-

<sup>4</sup> The ropes are attached to the conveyance so that all four can pull from the same side, or two from either side



viding regulated and unregulated braking.

### Hoist control

This is housed in the hoist control cubicle, the front of which has a control panel with a modern MMI (man-machine interface). This panel is used mainly during maintenance work.

The implementation of the hoist was complicated by the variable incline, which changes from plus 20 percent to level and then to minus 20 percent – a transition the payload is expected to make without a jolt.

The hoist control PLC (programmable logic controller) deals with all control and safety aspects of the hoists. It is basically a standard ABB mine hoist control system with additional functionality to cater for the specific features of this hoisting plant. One of the distinctive features of this system is the position determination of the conveyance. The system receives position signals from all hoists via incremental encoders. The position and speed of the hoists in transition areas do not reflect the speed and position of the conveyance. The hoist control PLC therefore has a software function to ensure a “jolt-free” and accurate transition of speed and position signals from one pair of the hoists to the other.

### Hoist control stations

The BCMR hoisting system has a total of seven hoist control stations. In normal operation, the conveyance control station is used. This communicates with the system using a radio link. The other control stations are for maintenance and inspection purposes.

### Hoist drive system

The railway has two digital ABB drives of type DCS-502. One drive controls the east hoists and the other the west hoists. For maintenance purposes, each drive can be switched to permit operation with a single motor.

The drive software has many features that were purpose-designed for this hoisting system. They include:

- Speed or torque control mode, depending on the load scenario (direction of run and position of the conveyance).
- In torque control mode, the torque (current) can either follow the torque of the other hoist pair or be set to provide minimum rope tension.
- A gentle “jolt-free” transition occurs between the modes.
- Different logic and parameters are used when operating with a single motor.

Both drives feature EMF (electromotive force) Control as is frequently used in ABB hoist drives. In this hoisting system, both motors reach their rated voltage when the speed attains 70 percent. After this speed-up, the voltage of the motors (EMF) is maintained constant by controlling the motor field. Such a control strate-

**Factbox** Requirements for Big Chute Marine Railway

The requirements on the hoist control, drive and braking system include:

**Drive and control system**

- To ensure equal rope tension in each pair of hoists, that pair must at all times maintain an identical rope pull and rope displacement.
- When all hoists operate in the same mode (motoring or regenerating), the momentary rope pull of all 4 hoists must be identical.
- To prevent the slackening of ropes, when one pair of hoists operates in motoring mode and the other in regenerating mode, the rope pull of the hoist pair acting on the conveyance from the downhill side must be constant.
- Because in the transition point area, the speed of one pair of hoists does not reflect the speed of the conveyance (in fact this pair changes direction in this area), the other pair of hoists must control the speed (and position) in that area, ie in the east transfer point area, the west hoists are responsible for speed and position control. The transi-

tion of speed/position control from one pair of hoist to the other must be "jolt-free" and accurate.

- There must be a smooth and gradual torque (rope pull) change in each transition point from constant torque providing minimum required rope pull of one pair of the hoists to equal torque for all hoist and vice versa. This is to minimize speed oscillation which could be amplified by the combination of rope flexibility, rope weight suspended in horizontal runs and high mass of the conveyance with payload (close to 200t).

**Brake system**

- Regulated emergency braking controls are used because emergency braking must be smooth and safe under different load conditions.
- Emergency braking torque must be differentiated between each pair of hoists when needed. For example, during downhill running from the eastern to the western transition point, the emergency braking force (torque) acting on the conveyance is to be

provided only by the east hoists. The braking torque on the west hoists must be smaller than that required to slow down the rotating masses of these hoists, thus preventing slack rope condition and at the same time eliminating "bounce", which could occur if these hoists did not provide braking at all.

- When running uphill on the west slope (all hoists in motoring mode), the emergency braking torque must be minimal, so that the hoist drums do not decelerate faster than gravity can slow the conveyance. This prevents excessive slack rope condition. Furthermore, after stopping, a reduced mechanical braking torque must be applied initially to provide gentle roll-back of the hoists (and conveyance) during the "whiplash" effect caused by the slackened ropes. This reduces rope tension during the "whiplash" action and also reduces the "bouncing" effect the conveyance would be subjected to if full braking force were applied immediately after the hoists stopped.

- 5 This view of the hoist room showing all four hoists gives an idea of how restricted space is in this building



- 6 Mine hoist technology from ABB is not out of its depth when hauling ships. These are the brake control valves.



gy has numerous benefits: Negative effects of the drive on the network are reduced (through better power factor, lower voltage drop, and lower harmonic distortions). The AC ripple current in the motors is reduced, as is the DC short circuit current (motor short circuit torque).

**Plain sailing thanks to ABB**

The hoist can handle a payload of up to 90t. A single journey takes 15 min-

utes, and since opening, 11,000 boats have been transferred.

The hoisting system has proven its reliability and operated without a problem throughout the guarantee period. Parks Canada is very satisfied with its performance. This unique installation confirms ABB's mine hoist expertise and the quality of this equipment.

**Klaus Kacy**

ABB Automation, Mining Division  
Burnaby, BC, Canada  
klaus.w.kacy@ca.abb.com

**References**

- [1] Kacy, K, 1998. Advantages Of Digital Control In Mine Hoist Applications. CIM Conference in Montreal, Canada.
- [2] Kacy, K, Brian O'Neil, 2005. Multiple Hoisting System for Incline Haulage with Positive and Negative Slope. Hoist & Haul 2005 Conference, Perth, Australia.