

Spares List

600T Series Electronic Transmitter Mod. 653

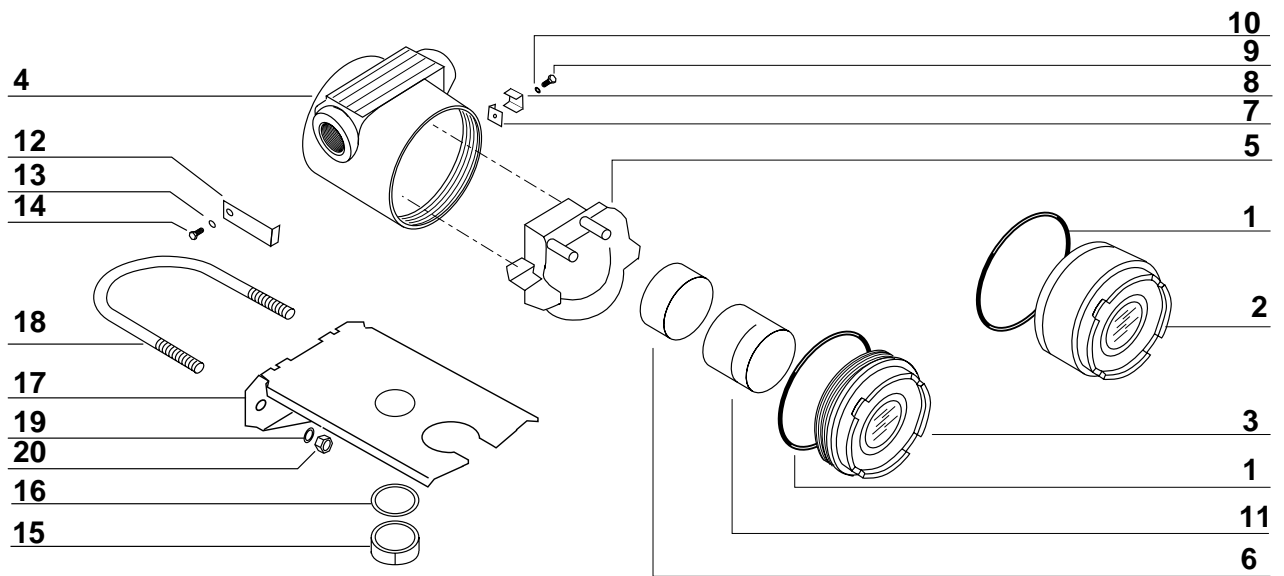

Item no.	Description	Categ.	Part N°	Q.ty per Tx
1	"O"Rings for cover	B	2001.3362	1
2	Windowed cover for LCD meter: - Aluminium - AISI 316 L ss (except Factory Mutual) - AISI 316 L ss (for Factory Mutual)		AC5-15-20390 AC5-15-20500 AC5-15-20580	1
3	Blind cover: - Aluminium - AISI 316 L ss		AB5-15-20070 AB5-15-20570	1
4	Electronics housing : - 1/2 NPT electrical connections in aluminium - M20 electrical connections (remote sensor) in aluminium - 1/2 GK electrical connections (remote sensor) in aluminium - Pg 13.5 electrical connections (remote sensor) in aluminium - M20 electrical connections (integral sensor) in aluminium - 1/2 GK electrical connections (integral sensor) in aluminium - Pg 13.5 electrical connections (integral sensor) in aluminium - 1/2 NPT electrical connections in AISI 316 L ss - M20 electrical connections (remote sensor) in AISI 316 L ss - 1/2 GK electrical connections (remote sensor) in AISI 316 L ss - Pg 13.5 electrical connections (remote sensor) in AISI 316 L ss - M20 electrical connections (integral sensor) in AISI 316 L ss - 1/2 GK electrical connections (integral sensor) in AISI 316 L ss - Pg 13.5 electrical connections (integral sensor) in AISI 316 L ss		AC0001 AC0002 AC0003 AC0004 AC0006 AC0007 AC0008 AR0209 AR0210 AR0212 AR0211 AR0213 AR0215 AR0214 AR0184	1
5	Terminal block	A		1
6	Electronics assembly (Refer to model 652 price list) • Economical - General Purpose and Flameproof version - Intrinsic Safety version • Programmable - General Purpose and Flameproof version - Intrinsic Safety version • Smart HART programmable - General Purpose and Flameproof version - Intrinsic Safety version	B	6523000000000000 6524000000000000 6525000000000000 6526000000000000 6527000000000000 6528000000000000	1
7-8-9-10	Kit : External earth connection		DR0022	1
11	Indication meter (LCD)		DR0039	1
11-2-1	LCD digital indicator kit complete of windowed cover and "O" ring		DR0083	1
12-13-14	Kit : locking fastener for covers (Flame-proof version only)		AR1-15-52040	1
15	Lock nut		AB5-15-01750	1
16	Plain washer for lock nut		AB5-15-01740	1
17	Bracket - Carbon steel - AISI 316 L ss - AISI 316 L ss for ss housing		AB5-15-00890 PC0005 AP0360	1
18-19-20	Mounting kit for bracket - Carbon steel - AISI 304 ss		AR1-15-50270 DR0073	1
17-18-19-20	Bracket kit - Carbon steel - AISI ss - AISI ss for ss housing		DR0076 DR0077 DR0131	1

Note : Kits contain parts for one transmitter.

Recommended spares : one part of category "A" for every 25 transmitters
one part of category "B" for every 50 transmitters



The Company's policy is one of continuous product improvement and the right is reserved to modify the specifications contained herein without notice.

SL/653 Rev 3

ABB Instrumentation spa
Via Statale 113
22016 Lenno (Como)
Italia
Tel. (0344) 58111
Facsimile (0344) 56278

ABB Automation Ltd.
Howard Road
St. Neots, Cambs.
England PE19 3EU
Tel. (01480) 475321,
Facsimile (01480) 217948

ABB Automation Inc.
125 East County Line Road
Warminster, Pa
18974-4995 USA
Tel. (215) 674-6693/6320/6777
Facsimile (215) 674-7184