



A team of drives

Multidrives with active front-end technology in the cement and minerals industry
Rolf Hoppler, Urs Maier, Daniel Ryf, Leopold Blahous

Drives represent a huge chance for energy savings. Especially in variable-speed applications, considerable savings can be obtained when a drive is adopted. The drive supplies the voltage and current to the motor that is needed to take it to the required speed. This is much more efficient than the traditional way of running the motor at a constant speed and using dampers or similar elements to throttle flow.

However, the savings often become apparent only during the lifetime of the equipment, and many customers

prefer not to adopt the technology due to higher initial costs. So how can one cut these costs?

ABB's response is multidrives. Normally, every drive has a rectifier and an inverter. The rectifier converts the AC from the net to DC, which the inverter then converts to AC of the required frequency and voltage. Obviously, every motor needs its own inverter to permit it to be controlled individually. But the rectifiers can be combined into a single larger unit. This is the basic concept of a Multidrive.

The cement and minerals industry has applications that see the use of multiple drives in close physical proximity to each other; and furthermore, where the use of variable-speed drives is desirable for many or all applications. In most cases, however, such drives are not adopted because of the higher initial investment costs they imply and because their benefits become visible only after operation has started up. Variable-speed drives (VSD) also create harmonics in the network and may require passive or active filters. Installation of these calls for a comprehensive study of the network in order to avoid undesired effects due to resonance with the harmonics, which the frequency converters of the variable-speed drives generate on the network side.

Using variable-speed multidrives, where the process permits this, overcomes several of these hurdles and permits compensation of some of the reactive power that the fixed speed motors consume due to the high power factor of VSDs.

Variable-speed and multidrives

Today's variable-speed drives in the low and mid power range are normally based on the concept of variable voltage, variable frequency (VVVF). 1 shows the basic concept of a single variable-speed drive.

The three-phase AC supply network is rectified. The DC capacitor, which links the supply rectifier to the inverter, assures that the inverter sees a constant DC voltage from which it generates the required supply voltage and frequency to the motor.

In low-voltage applications, ie, with a supply voltage between 400 and 690 V RMS (root mean square) the inverter has IGBT (insulated-gate controlled bipolar transistor) semiconductors, which have an extremely high switching frequency and provide the proper dynamic for

the motor to follow all changes in the process parameters.

In the cement and minerals industry, multidrives are typically used in the low-voltage range.

Several geographically close variable-speed drives can be combined to a multidrive with a common 6-pulse, 12-pulse or active front-end rectifier. Even in case of active front-end converters all the advantages can be maintained.

The loop, which for example, controls the speed of the motor can be open or closed between the inverter and the motor itself, depending on the

application. The prime task of the rectifier is to keep the DC voltage constant. In its simplest form, the rectifier is a diode rectifier. In this case there is no limitation in accelerating the motor, but when the speed must be reduced, the setup is limited because the kinetic energy of the motor and its driven machine has to be decreased. The only place the energy can flow is into the DC capacitor, whose voltage rises as a result. The standard solution in situations where a four quadrant operation is required is to include a braking chopper. This discharges the capacitor into a braking resistor and thus transforms the excess mechanical energy of the motor into heat. Obviously, this is not a very energy-efficient approach in cases where braking occurs often or continuously.

A technically attractive alternative would be to replace the diode rectifier by an IGBT rectifier. This solution permits the mechanical energy of the load to be fed back into the supply network during braking operations, ie, making it available to other consumers in the network. 2 shows this solution. The IGBTs are represented by very fast switches.

The main setback of this solution is that if each individual variable-speed drive has an active front-end rectifier, the initial investment cost of these drives is higher than the scenario with diode rectifiers.

Several geographically close variable-speed drives can be combined to a multidrive with a common 6-pulse, 12-pulse or active front-end rectifier. Even in case of active front-end converters all the advantages can be maintained at a reasonable investment, which is not only technically but also economically attractive.

Multidrive basics

3 shows the basic structure of a multidrive. The central concept is that there is a

1 Base circuit of a variable-voltage variable-frequency drive

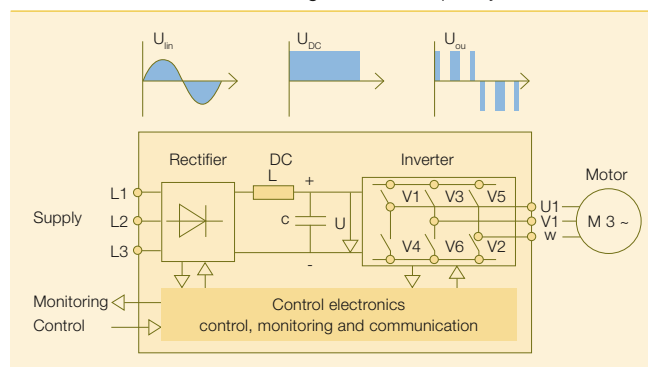

2 Schematic of a frequency converter with IGBT rectifier and inverter

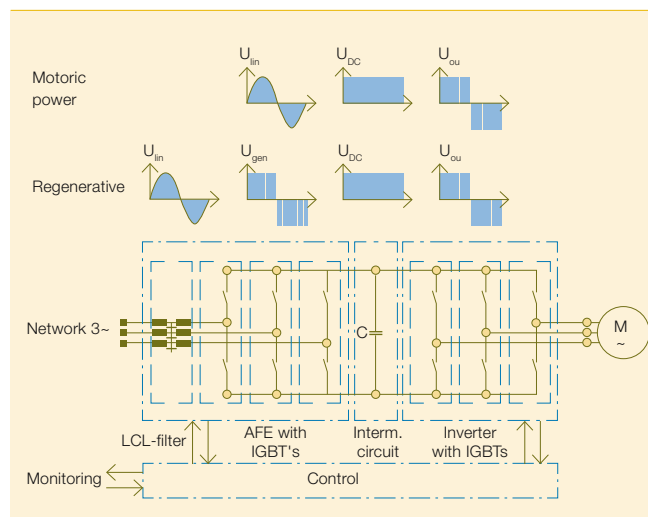

Drives

3 Basic structure of a multidrive

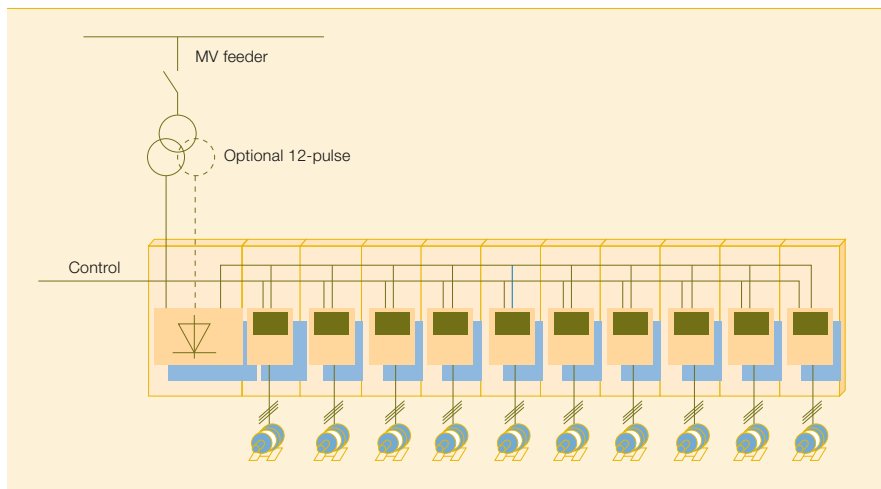

common rectifier in 6-pulse, 12-pulse or active front end configuration for all individual inverters. The individual inverters may have quite different power ratings and even performance requirements because, as already mentioned, the control loop only involves the individual inverter. Multidrive allows motor to motor braking via the common DC-bus, independently of the type of rectifier used. The rectifier in 3 is represented by a diode but in case of multidrives the additional investment to make it an active front-end converter, ie, also use IGBTs on the rectifier side, is, relatively speaking, much lower than in the case where all individual independent variable-speed drives have their own rectifier.

A three-winding transformer for the diode rectifier is shown in 3. This topology reduces the harmonics that the multidrive generates on the supply side when 12-pulse diode rectifiers are used. If a certain redundancy is required by the application, each secondary winding has its dedicated six-pulse diode bridge that can take part of the load of the second bridge should this bridge fail. This means the loss of one rectifier bridge does not imply the loss of all variable-speed drives connected to the rectifier. The modularity of the three-phase converter semiconductor modules additionally permits

the spare part stock to be kept very low while permitting any failed module to be replaced quickly by an electrician.

Moreover, the multidrive offers additional benefits, which also need to be considered when making an investment decision.

Additional benefits of Multidrive

Efficient use of active power

As has already been mentioned, the relative cost of the rectifier decreases as do the investment costs when using IGBT semiconductors for the rectifier. When four-quadrant operation is required, the IGBT-based rectifier per-

mits mechanical energy from the motor and its connected equipment to be fed back into the supply, meaning this need not be wasted in braking resistors.

Reactive power compensation

The IGBT converter actively builds the supply voltage on the inverter side; it is therefore able to force a predetermined phase shift for current and voltage in the supply network. In other words it can make the variable-speed drive look capacitive or inductive for the supply network in a certain range. This is shown in 4 where the rectifier appears as a capacitive load from the three-phase AC supply network.

This means the active front-end rectifier can be used to compensate reactive power consumption of fixed speed motors in the supply network.

The clinker cooler is predestined for multidrive variable-speed drives. The cooler requires a continuously changing air flow in order to provide proper cooling of the clinker.

Low harmonics

Low-power variable-speed drives use only six-pulse diode rectifiers. The six-pulse operation results in a rather distorted current as shown in 5. Using an IGBT rectifier, a significantly better approximation of the network current to an ideal sine can be achieved 6.

Consequently, the disturbance that the active front-end multidrive causes in the supply network is very low. It should be mentioned that the low harmonic content in the active front-end rectifier current was achieved without recourse to a three-winding transformer (which would have helped reduce harmonics were 12-pulse diode rectifiers to be used).

4 Capacitive phase shift of current and voltage at the supply side of an active front-end drive (ie, with an IGBT rectifier)

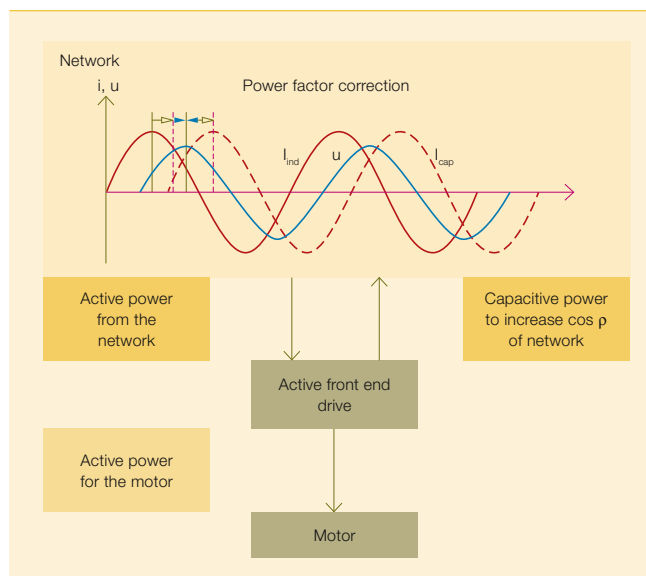

5 Current harmonics for 6-pulse diode rectifier

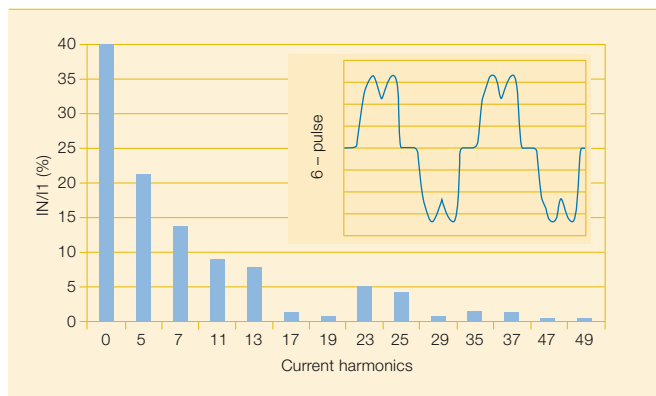

6 Current harmonics for IGBT rectifier (active front-end)

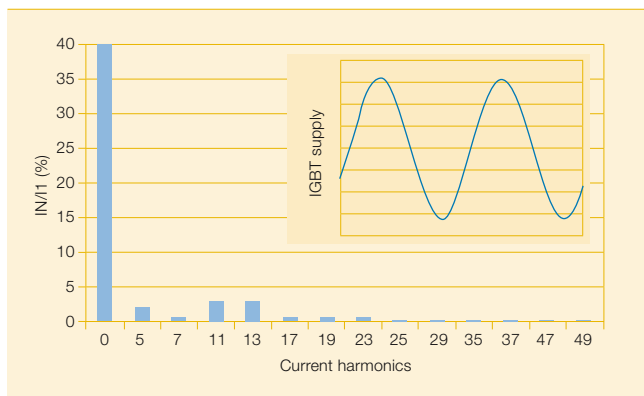

The L-C-L filter in the rectifier permits operation without further filters. A simple two-winding transformer (should it be needed) is sufficient to meet the standards for harmonic distortion in the supply network. The converter transformer thus becomes simplified in two ways:

- It can be implemented as a simple, two-winding transformer enabling a common spare for power distribution and variable-speed drives.
- Its harmonic load is much lower than in standard rectifier applications.

Additional benefits

Due to the compact structure of the multidrive, the individual inverters do not need a separate feeder in the motor control centers (MCC) or in the feeder panels. The protection of the motor is achieved using the inverter itself. Each inverter can be disconnected from the DC-bus by its own lockable load switch.

Because of balancing by motor-to-motor braking between the motors attached to the same DC supply, rapid load changes – even when they create regenerative energy – do not need to be fully compensated by the supply network.

Applications

Clinker cooler in cement plants

The clinker cooler is predestined for multidrive variable-speed drives. The cooler requires a continuously changing air flow in order to provide proper cooling of the clinker. By using variable-speed drives, the very expensive electric energy is not wasted by reducing the maximum air flow via flaps. Instead it is adapted using the motor speed and power using a fast responding variable-speed drive.

7 shows a “simple” solution for a cooler multidrive.

In the case of 7, the two rectifiers are still of the conventional 6-pulse diode type with a certain redundancy resulting in a 12-pulse configuration together with the phase shift in the three winding transformer (when seen from the AC supply network). Each of the inverters has its own individual control interface.

There are process concepts for the clinker cooler that also require the integration of the exhaust air fan into the cooler multidrive system. In cases in which the air pressure at the kiln outlet is to be kept within extremely tight tolerances, the exhaust-air fan and the cooler fans need to be operated in close coordination. This also means that the exhaust-air fan needs the capability for four-quadrant operation. This may result in cumbersome, large and heavy panels if this is implemented with braking choppers and resistors alone. A variable-speed multidrive allows braking via DC-bus or

7 Cooler multidrive schematic [1]

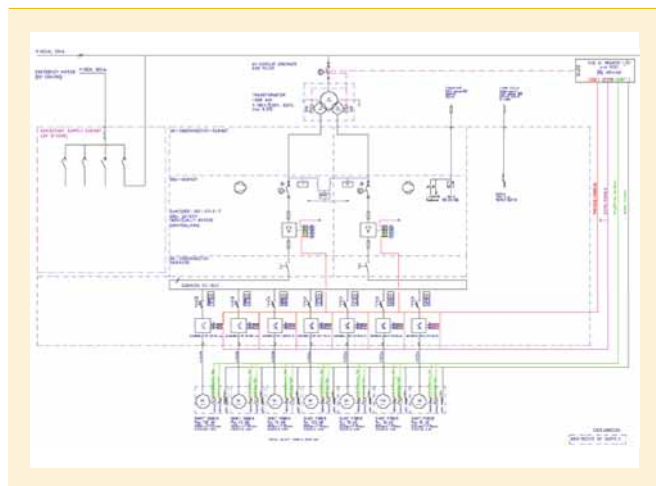

8 Schematic of the multidrive for a downhill belt conveyor system [2]

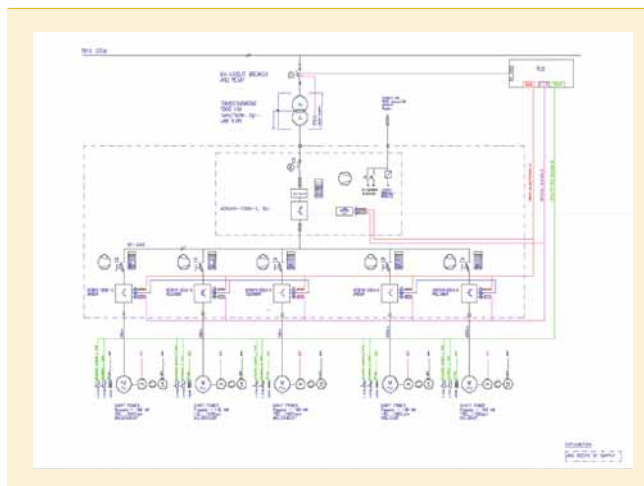

Drives

in case of active front-end technology the braking energy will be fed back into the network.

Downhill belt conveyors

Very often, the quarry is not located right next to the plant. Not all plants are permitted to use trucks to transport the material from the quarry to the plant. In this case, only belt conveyors can be used. **9** shows such a situation where the material had to be transported downhill from the quarry to the plant [2]. For this specific case, the variable-speed drives were located close to one-another. The head-end drives of the tube conveyors were located in the same building as the tail end drives for the troughed belt conveyors.

9 shows the single-line schematic of the multidrive. In this example, the active front-end technology was fully applied because during operation and

9 Example of a downhill belt conveyor [2]



- a** Tail-end troughed belt conveyor with three motors
- b** Head-end tube belt conveyor
- c** E-house with drives

10 Multidrive panels for the downhill conveyor [2]



Factbox Advantages of multidrives in the cement and minerals industry

- Optimizing the process by providing the process optimum drive solution
- Reducing wear by smooth starting and stopping of the mechanical equipment
- Reducing the impact of starting and stopping an individual drive on the reactive and active power consumption of the supply network
- Simplify the electrical installation because the multidrive has the low voltage distribution integrated and thus requires less cabling
- Less space requirement in case of multidrive
- Complete factory tested multidrive system
- Distribution-Transformer capacity of MCC supply smaller because of own transformer for multidrive
- Less various components, interfaces and therefore engineering
- Less spare parts
- Low harmonic content on Distribution-Transformer and equipment connected to MCC

Additional benefits with active front-end

- Reducing the harmonics without filters, and thus avoiding the complex interaction of the filter with the supply network and therefore lengthy network studies
- Permitting use of two-winding transformers, which have the additional advantage of a significantly reduced harmonic load
- Compensating reactive power without needing capacitors or filters
- Make optimum use of the most expensive energy source (electricity) in the plant

starting with a loaded belt, the drive actually has to start from a braking condition. This specific project permitted the use of the same motors for all drives. The drive internal control system ascertains that all variable-speed drives of a belt are working in load sharing. Further more the overriding control system cares that each drive is supplied only with exactly the acceleration or braking torque to avoid damages to the belt while permitting optimum material flow on the conveyor. **10** illustrates how compact the multidrive for the specific downhill conveyor application actually is.

A variable-speed multidrive allows braking via DC-bus or in case of active front-end technology the braking energy will be fed back into the network.

Multidrive: multiple advantages

Variable speed multidrives offer significant technical advantages in several key applications of cement making that are normally overlooked when only taking the single investment cost of a multidrive into consideration. Some of these advantages are listed in

Factbox

When taking all of these aspects into account, the variable speed multidrive is a technically and commercially attractive alternative to conventional drive concepts in cement making and the minerals process. The two examples that were introduced in this article clearly illustrate the process flexibility that is obtained through proper application of the multidrive concept in cement making.

Rolf Hoppler

Urs Maier

Daniel Ryf

Leopold Blahous

ABB Process Automation

Baden-Dättwil, Switzerland

rolf.hoppler@ch.abb.com

urs.maier@ch.abb.com

daniel.ryf@ch.abb.com

leopold.blahous@ch.abb.com

References

- [1] **Hoppler, R.** (2005). An optimized drive solution for the cooler area. ZKG International 2.
- [2] **Lüchinger, P., Maier, U., Errath, R.** (2006). Active front end technology in the application of a downhill conveyor. Cement Industry Technical Conference, IEEE, Phoenix, AZ (p. 20).