



DATASHEET

GECKO SP1/3/5

V1.0

1 Datasheet

Gecko SP1/3/5

General Properties		SP1	SP3	SP5	Unit
Maximum Payload		1	3	5	[kg]
		2.2	6.6	11	[lb]
Preload	MIN	3	8	12	[N]
	Medium	7	20	29	[N]
	MAX	11	32	46	[N]
Detachment time		100-1000 (dependent on robot speed)			[ms]
Holds workpiece on power loss?		Yes, for days if well centered			
IP Classification		IP42			
Dimensions (HxW)		69 x 71			[mm]
		2.7 x 2.8			[inch]
Weight		0.267	0.297	0.318	[kg]
		0.587	0.653	0.7	[lb]

Pads general properties	Unit
Material	Proprietary silicone blend
Wear properties	Depends on surface roughness
Change-out interval	~200.000 [cycles]
Cleaning systems	1) OnRobot cleaning station 2) Silicone roller 3) Isopropyl Alcohol and lint-free cloth
Cleaning interval	variable
Recovery	100%

Conditions	Minimum	Optimal	Maximum	Unit
Operating temperature	0	-	50	[°C]
	32	-	122	[°F]
Storage temperature	-30	-	150	[°C]
	-22	-	302	[°F]
Surface Characteristics	Matte finish	Highly polished	N/A	Note: Smoother surfaces require less preload force for a desired payload force.
Spring lifetime*	1000000+	-	-	cycles

* Replacement information in the Maintenance section.

How to pick a part using the Gecko Gripper SP

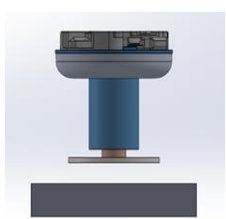
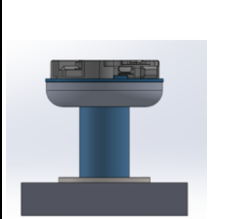
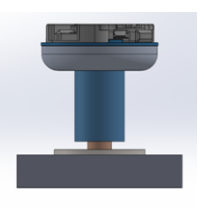
Grip		
		
Position	Contact & Preload	Lift

How to release a part

Method 1 – Robot Peeling Movement:

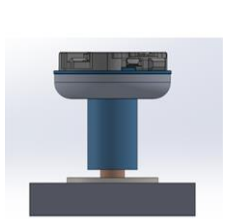
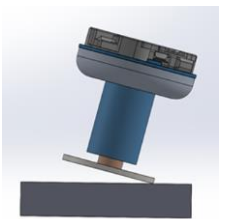
Release	
	
Place	Tilt to Release

Method 2 – Fixturing:

It is also possible for users to craft their own custom fixture to assist in peeling off an object if the above method is not desirable. For example, the Gecko SP1/3/5 could grip a panel and then visit a forked tool to slide between, move up and release the object. The fixture design is completely at the user’s discretion.

Usage Notes:

Because of the Gecko Gripper SP’s unique mechanism of action, it is important to understand the following key operating principles to use the gripper correctly and to achieve optimal gripper performance. This is VERY important.

- **Surface Roughness Affects Gripping**
 The Gecko Gripper works best with highly polished surfaces that allow for maximal contact between the adhesive pads and the substrate surface. As the surface becomes less smooth, more preload force is required to grip substrates. Matte surfaces should be considered the maximal surface roughness limit which the gripper is able to grip.
- **Environmental Conditions Affect Gripping**
 The adhesive pads use van der Waals forces to attach to a substrate. If there is dust or debris on the substrate surface, the pads will interact with these particles instead. Dusty, greasy, oily, or wet substrates will not adhere to the Gecko Gripper SP. The Gripper works best with clean, smooth, and dry surfaces.
- **Preload Force Determines Maximum Payload Force**

The adhesion force is also dependent on the amount of preload force applied to the surface. This preload force also depends on the surface smoothness or roughness. Payload force is also saturable at some preload force specific to the material and operating conditions; here maximal preload is applied.

- **Reconcile Gripper Function with Robot Collision Detection or Other Safety Systems**

When using the Gecko Gripper with a robot in position control, care must be taken during the gripping phase of the object as to not trip off the robot’s collision detection system. The most force of the gripper is dependent on pad size. Approximate maximum force values for the SP gripper series are as follows: SP1 = 15N; SP2 = 40N; SP3 = 60N. Based upon your robot type and object, it may be necessary to adjust the robot’s collaborative or collision settings to preclude tripping off the robot upon contact.

- **Pick Location and Object Moments Can Overcome Gripping Force**

Gripper adhesion specifications assume that the center of gravity of the object is centered on the gripper pad. If the center of gravity of the object is not centered on the pad or moments are applied to the object, robot-object movement can decrease the adhesion force of the gripper causing it to drop the objects.

- **Pads will Wear Out**

Over time, the gecko pads will wear and require replacement. There is no deterministic way to determine how worn the pads are, so the user must be mindful of the pad change-out interval. This will depend on the environment in which the pads are used.

Effectiveness on Different Materials

There are several factors that affect the gecko gripper’s ability to handle items: the micro scale roughness of the surface (average roughness), the macro scale peaks and valleys on the surface (spatial frequency of peaks – also waviness), also the orientation of these features (lay – or the way it was finished, e.g. lapped, ground, Blanchard, etc.) and stiffness of the material. If the material is too soft, the gecko adhesive will not be able to force itself against the material to grip. To make this easier to interpret, we have included the below table that shows texture roughness and stiffness on the left (scales of 1, 5 and 10 – the highest) versus the payload of the Gecko SP1, SP3 and SP5. Green indicates that it is possible to pick this object, yellow is questionable and red does not result in a pick. The scale is relative and semi-arbitrary, meant to act as a general guide. More scientific information can be found in the Gecko SP user guide.

Stiffness	Roughness	Example of material / substrate	Gecko SP-1						Gecko SP-3						Gecko SP-5					
			Payload [kg]						Payload [kg]						Payload [kg]					
			0.02	0.05	0.1	0.25	0.5	1	0.1	0.2	0.3	0.75	1.5	3	0.1	0.25	0.5	1.0	2.5	5
1	1	Loose Mylar	Yellow	Yellow	Red	Red	Red	Red	Yellow	Yellow	Red	Red	Red	Red	Yellow	Yellow	Red	Red	Red	Red
5	1	Transparency sheet	Green	Green	Yellow	Yellow	Yellow	Red	Green	Green	Yellow	Yellow	Yellow	Red	Green	Green	Yellow	Yellow	Yellow	Red
10	1	Polished mirror-like steel, metal, solar panel	Green	Green	Green	Green	Green	Green	Green	Green	Green	Green	Green	Green	Green	Green	Green	Green	Green	Green
1	5	Cling film, ziploc bags	Yellow	Red	Red	Red	Red	Red	Yellow	Red	Red	Red	Red	Red	Yellow	Red	Red	Red	Red	Red
5	5	Glossy carboard (cereal box)	Green	Green	Yellow	Yellow	Red	Green	Green	Yellow	Yellow	Yellow	Red	Green	Green	Yellow	Yellow	Yellow	Red	
10	5	Printed circuit board	Green	Green	Green	Yellow	Red	Green	Green	Green	Yellow	Red	Red	Green	Green	Green	Yellow	Red	Red	
1	10	Laminating plastic / film	Red	Red	Red	Red	Red	Red	Red	Red	Red	Red	Red	Red	Red	Red	Red	Red	Red	Red
5	10	Corrugated cardboard	Yellow	Red	Red	Red	Red	Red	Yellow	Red	Red	Red	Red	Red	Yellow	Red	Red	Red	Red	Red
10	10	Sandblasted aluminum	Yellow	Yellow	Red	Red	Red	Red	Yellow	Yellow	Red	Red	Red	Red	Yellow	Yellow	Red	Red	Red	Red



NOTE:

This table is to be utilized as a guide to better understand the payload capacity and substrate type for the Gecko Gripper SP1/3/5.

The criteria for stiffness and roughness is a basic scale from 1-10, here are the benchmarks used to determine the values.

Stiffness	Description	Example
1	Flexible	Fabric
5	Semi-flexible	Cardboard
10	Stiff	Metal

Roughness	Description	Example	RMS Value
1	Polished/Smooth	Polished Metal	0.1 micron
5	Textured	Carboard	7 microns
10	Rough	Sandblasted Metal	28 microns

Gecko SP1/3/5

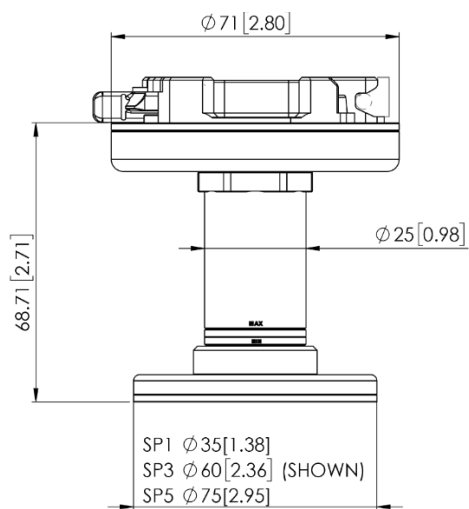

All dimensions are in mm and [inches].