



## Co-act EGP-C for ABB CRB15000 GoFa

Gripping unit suitable for collaborating robots with the specific connection to the ABB CRB15000 GoFa

### Your advantages and benefits

- Gripping unit for collaborative robot
- Certified gripping unit saves effort for safety assessment of the application
- Plug & Work with ABB CRB15000 GoFa
- Control via digital I/O

### Technical data

- |                                 |                              |
|---------------------------------|------------------------------|
| • ID                            | 1468551                      |
| • Size                          | 64                           |
| • Stroke per jaw                | 10 mm                        |
| • min. / max. gripping force    | 65 / 230 N                   |
| • max. admissible finger length | 80 mm                        |
| • Weight                        | 1.38 kg                      |
| • Mechanical interface          | EN ISO-9409-1-50-4-M6        |
| • Nominal voltage               | 24 V DC                      |
| • Electrical interface          | M8 4-pole / M8 3-pole        |
| • Sensors                       | Inductive proximity switches |

Please contact us with your individual requirement.  
You can reach the Co-act Team at:

Hotline Co-act Team +49-7133-103-3444  
E-mail: [Co-act-team@de.schunk.com](mailto:Co-act-team@de.schunk.com)

# Co-act EGP-C for ABB CRB15000 GoFa

Customer specific gripping unit

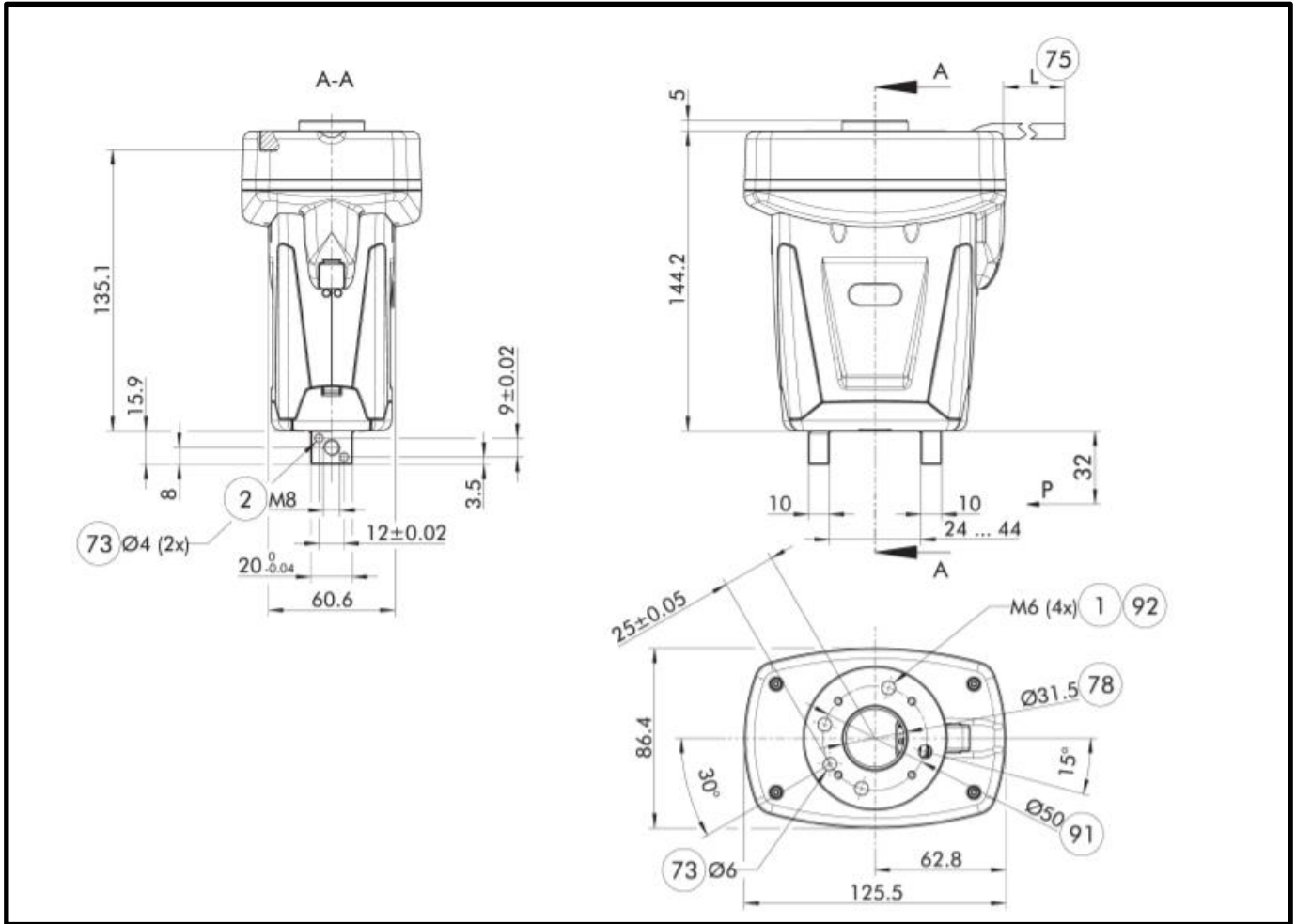

*J. Lehmann*

Jens Lehmann, deutsche Torwartlegende,  
seit 2012 SCHUNK-Markenbotschafter  
für sicheres, präzises Greifen und Halten.  
[schunk.com/Lehmann](http://schunk.com/Lehmann)

SCHUNK GmbH & Co. KG  
Spann- und Greiftechnik

Bahnhofstr. 106 - 134  
D-74348 Lauffen/Neckar  
Tel. +49-7133-103-0  
Fax +49-7133-103-2399  
[info@de.schunk.com](mailto:info@de.schunk.com)

 [schunk.com](http://schunk.com)  
[youtube.com/schunkhq](http://youtube.com/schunkhq)  
[twitter.com/schunk\\_hq](http://twitter.com/schunk_hq)  
[facebook.com/schunk.hq](http://facebook.com/schunk.hq)  
[schunk.com/lehmann](http://schunk.com/lehmann)

