

Type RC Automatic Reclosing Relay

Effective: June 1997
Supersedes I.L. 41-661.1A, Dated February 1994

(I) Denotes Changed Since Previous Issue



Before putting relays into service, remove all blocking which may have been inserted for the purpose of securing the parts during shipment, make sure that all moving parts operate freely, inspect the contacts to see that they are clean and close properly, and operate the relay to check the settings and electrical connections.

1.0 APPLICATION

The type RC automatic reclosing relay is used for automatic reclosure of ac or dc electrically operated circuit breakers after they have been opened by over-current or other protective relay action. The relay may be adjusted to provide several reclosures at predetermined time intervals, so that in case the breaker does not remain closed after the first reclosure additional reclosures will be made. The first reclosure usually is an instantaneous reclosure through pre-closed contacts since system operating experience has shown that the majority of faults are of a temporary nature, such as lightning flashovers, and will not be re-established after interruption of the fault current. Consequently, service interruption can be minimized by the use of an instantaneous reclosure. However, the first reclosure may be delayed if desired.

In case the circuit breaker does not remain closed after the first reclosure, the relay will make additional reclosures at suitably graded intervals. It is common practice to make two additional reclosures, but the

relay may be adjusted to make any number up to a total of six reclosures if desired. If the breaker does not remain closed after the final reclosure, the timing drum stops in the "LOCKOUT" position, and any further attempts at reclosure must be made by manual operation of the control switch. However, if the breaker remains closed after any automatic reclosure, or, subsequently, after manual reclosure, the relay timing drum will advance to and stop at the "START" position, where the relay is in readiness for another cycle of automatic reclosures following the next tripping of the breaker.

For any automatic reclosing application, the derating factors for breaker interrupting ability should be checked when choosing any particular reclosing cycle. Also, when using instantaneous first reclosure it is necessary that the protective relays open their contacts within 10 cycles or less after the breaker is tripped in order that the trip circuit will be de-energized before reclosure takes place.

The resistor and capacitor circuit across the #3 or #4 contact is a high impedance circuit. It provides a suppression function for the dc close application, but should be disconnected for the ac close application because sensitive auxiliary relays in the breaker close circuit may stay picked up.

2.0 CONSTRUCTION

As shown in Figure 1, the RC relay consists of a latching solenoid unit, Y, a synchronous motor driven timing unit, and an instantaneous auxiliary unit, X. An additional instantaneous unit, Z, is also provided when specified.

All possible contingencies which may arise during installation, operation or maintenance, and all details and variations of this equipment do not purport to be covered by these instructions. If further information is desired by purchaser regarding this particular installation, operation or maintenance of this equipment, the local ABB representative should be contacted.

2.1. TIMING UNIT

The timing unit contains a synchronous motor and gear train mounted behind the front sub-base. The gear train drives a drum with cams, which actuate contacts 1, 2, 3, 4 and 14. Cam 5 actuates the Y unit latch to reset the Y unit and close the Y13 contact. Cams #1 and #2, which operate contacts 1 and 2 respectively, are notched and are not intended to be adjusted in the field. Cam #3 is a series of flat springs secured by screws, which can be located at any point on the periphery of the drum. Cams #4 and #5 consist of screws which can be set at any point on the periphery of the drum. Cam #14 is a single Micarta block, located at the rear of the cam #5 position and held by a #5 cam screw.

The gear train reduction ratio is adjustable. The drum speed dial contains indices, which are lined up with an index mark to mesh the proper gears for the desired drum speed. A clamping screw is provided at the edge of this dial. A push rod is located on the front of the drum to disengage the drum and permit free manual drum rotation.

The dial on the timing drum has 60 divisions (second intervals with 60 second drum speed). The edges of the #3, 4 and 5 cam slots have 12 equally spaced white marks corresponding to 5 second intervals with a 60 second drum speed.

2.2. Y SOLENOID UNIT

The Y unit coil is located to the rear of the front sub-base. When energized, a plunger is attracted toward the rear of the relay against a spring. A Micarta disc on the front end of the plunger actuates contacts Y5, Y6 and Y7. As the disc moves to the rear it releases the latch arm. When released, the latch arm is rotated counterclockwise by the tension of the moving contact spring of contact Y13 and a small helical spring. This rotation blocks the full reset when Y is de-energized. Thus, the Y unit has three positions as shown in Table 1. The Y unit, is reset by the #5 cam on the timing drum, which rotates the latch arm clockwise against the tension of the Y13 moving contact spring.

2.3. INSTANTANEOUS Z UNIT (WHEN USED)

The Z unit is a clapper type auxiliary relay (standard SG) with one make contact, Z10, and make-break contacts, Z11 and Z12.

Table 1
Y UNIT CONTACT POSITIONS

Plunger Position	Contact Position			
	Y5	Y6	Y7	Y13
Reset	Closed	Open	Open	Closed
Latched and De-energized (Intermediate)	Open	Open	Closed	Open
Energized	Open	Closed	Closed	Open

3.0 OPERATION

Operation of the relay and associated equipment will be described, using the external schematic in Figure 7, in conjunction with Figures 4 and 5, which show contact positions as a function of the drum position. Figure 5 is based on the factory cam adjustment; immediate, 15 and 45 second reclosures, with one drum revolution on 60 seconds. It is further assumed in Figure 5 that the instantaneous trip is locked out after the first reclosure, and the fault is not cleared prior to lockout.

3.1. MOTOR CONTROL

Motor energization is controlled by cams 1 and 2. In the start position the motor is energized through #1 and 52b contacts when the breaker opens. As the drum moves away from the start position, #2 contact closes to energize the motor through the 52a contact during the time that the breaker is closed. If the breaker is closed at the lockout position the drum will continue to rotate until the #2 contact opens at the start position. If the breaker is open, the drum will stop in the lockout position, since the #1, 52a and Y7 contacts are all open at this point.

Contact Y7 keeps the motor energized, when the breaker remains closed after an immediate reclosure, until the #2 contact can close. For this condition, 52b opens before the drum can rotate sufficiently to close the #2 contact. Contact Y7 has no significance during subsequent reclosing operations.

3.2. CLOSING SEQUENCING

The number of reclosures and the time at which they occur is determined by the location of the #3 cam screws, which close the #3 contact.

3.3. INSTANTANEOUS TRIP LOCKOUT

As shown in Figures 5 and 7, the trip circuit of the instantaneous trip units is opened by Y13 and 14 contacts from the time of the first reclosure until the drum returns to the start position. During the initial reclosing, contact Y13 is opened and remains open until the Y unit is completely reset at 6 seconds. The purpose of contact Y13 is to keep the trip circuit open until cam contact, 14, can be opened by the drum rotation. Contact Y13 has no significance during subsequent reclosing operations.

3.4. X-Y ANTI-PUMP CIRCUIT

Referring to Figure 7, when the breaker close circuit is energized through 52bb, Y5 and #3 contacts, the 79X coil is also energized. Then, X8 and X9 contacts seal around the Y5 contact and energize 79Y coil, respectively. Contact Y5 opens and remains open until the Y unit is completely reset at 6 seconds. As the breaker closes, 52bb contact opens, de-energizing the X and Y coils. Should the breaker immediately trip again, contacts Y5 and X8 will open to prevent premature energization of the breaker close circuit.

3.5. COMPLETE OPERATING SEQUENCE

3.5.1. Fault-Trip – Immediate Reclosure

With the timing drum in the “START” position (Figure 7), a #3 cam spring will be holding contact #3 closed. The breaker switch contacts 52b and 52bb close, energizing the motor 79M through contact #1, and the drum begins to rotate. At the same time the coil of the contactor unit, 79X, is energized through drum contact #3, and Y5. When the breaker latch-checking switch, 52LC, closes, the breaker control relay 52X is immediately energized through the pre-closed contacts Y5 and #3. This in turn energizes the closing coil of the breaker, 52CC. Simultaneously, contactor unit, 79X, seals in through its contact X8, while its other contact, X9, energizes the coil of solenoid unit 79Y to open contacts Y5 and Y13 and close contacts Y6 and Y7. As the circuit breaker closes, the breaker auxiliary switches 52b and 52bb open, and 52aa closes. Opening 52bb de-energizes 79X and 79Y. The latter then resets against its latch to open contact Y6 and remains in this position, thus leaving contacts Y5 and Y13 open and contact Y7 closed until the latch is released. Before the latch is released, the

drum operated contact, 14, will be opened and will remain open until the drum returns to the “START” position.

3.5.2. Preparing for Second Reclosure

The drum continues to rotate, since the motor is energized through Y7. When the breaker trips the second time, no immediate operation occurs. At about one second, #2 cam contact closes to set up the motor circuit when the breaker is subsequently reclosed. At about the three second drum position contact #3 opens. At about 6 seconds, the Y unit latch is released by the #5 cam, resetting the Y unit. The relay is now ready for another reclosure as soon as contact #3 is closed by the #3 cam spring. The drum will continue to rotate, since the motor is energized through 52b and #1 contacts.

3.5.3. Second and Third Reclosures

At 15 and 45 seconds the #3 contact closes to reclose the breaker. After each reclose, the Y unit is unlatched by the action of cam #5.

3.5.4. Lockout

When the drum reaches the lockout position, the motor is de-energized, since cam contact #1 opens (assuming the breaker is open). The breaker must then be closed by the control switch. If the breaker then remains closed the drum will rotate to the “START” position, where the motor is de-energized by the #2 cam contact.

3.6. OPTIONAL ARRANGEMENTS

Alternate operating arrangements as described below.

3.6.1. Reclosing Through Contact Y6

As shown in Figures 6, 7 and 8 the close circuit can be energized through contact Y6, where an independent contact is required or where a reclosing delay is desired. Y6 closes approximately 6 cycles after 79X is energized.

3.6.2. Lockout Alarm

A #4 cam screw can be set to close the #4 contact in the lockout position. By jumping terminals 4 and 6 and connecting terminal 7 to an alarm circuit, an alarm will be sounded when the breaker locks out.

3.6.3. Additional Instantaneous Tripping

Contact #4 can be set to re-establish the instantaneous trip circuit after the last reclosure and prior to lockout, if the instantaneous trip pickup is about equal to the time-overcurrent unit pickup. In this case re-establishment of the instantaneous trip insures breaker lockout if the fault current is near pickup value. The instantaneous trip circuit can alternately be re-established each time the Y unit is reset by short circuiting the #14 contact with a jumper.

3.6.4. Selective One-Shot Instantaneous Reclosing

By eliminating the #3 cam in the start position and by using terminals 16 and 17 with an external device, selective, instantaneous reclosing can be obtained. When the contact of the external device closes, reclosing will occur in the same manner as if #3 contact closed. Further reclosing by this means can be prevented by using either the Y13 and 14 contact circuit or by using the #4 contact circuit. In the latter case, the #4 cam is set for contact closure in the start position.

3.6.5. Relays with Z Unit

As shown in Figure 8 the Z unit is energized by a 52b contact. Z unit contacts perform the same functions as 52a and 52b contacts. The use of this unit reduces the number of control wires required.

3.6.6. Motor Operation From DC

An external inverter is available for operation of the motor from either 125 or 250 volts dc. The dc terminals of the inverter are connected in place of terminals 8 and 9 in Figure 7. Terminals 8 and 9 are then connected to the ac terminals of the inverter. This arrangement permits the use of an intermittently rated inverter, since the dc terminals are not continuously energized.

3.6.7. Automatic Reclosing with the RC and CVX-1, (CVE-1), Relays

The scheme in Figure 9 and the timing chart in Figure 10 illustrate automatic reclosing with RC reclosing relay and the CVX-1, (CVE-1) synchro-verifier relay with line and bus voltage units. The RC used here has internal wiring as shown in Figure 11. Comparable wiring may also be provided in an RC relay without the Z unit. Refer to I.L. 41-682 for data on the CVX-1 relay or I.L. 41-681.1 for data on the CVE-1 relay.

This scheme provides the following features:

- A. SELECTIVE INSTANTANEOUS RECLOSURE – following a high speed (HS) trip operation
- B. TIME DELAYED RECLOSURE WHEN:
 1. Line is hot and bus is dead
 2. Line is dead and bus is hot
 3. System is in synchronism
- C. INTERMEDIATE LOCKOUT

Should reclosing be otherwise unsuccessful the motor is stopped at an intermediate lockout position, with subsequent single shot reclosing only when the line becomes re-energized and is in synchronism with the bus voltage.
- D. MOTOR-SUPPLY TRANSFER

Should the bus become dead the motor supply is transferred automatically to line side potential.
- E. A contact is provided to actuate a time-delayed external alarm for intermediate lockout. Another independent contact is used to alarm for final lockout.

3.7. RC SETTINGS

In the RC relay per internal schematic 188A184 (Figure 11), the connection between contact #3 and the anti-pump circuit has been separated so that external devices can be connected between terminals 16 and 18, as shown in Figure 9. Some of the factory cam settings for the RC relay must be changed to provide timing as shown in Figure 10. The cam spring which pre-closes the #3 contact in the start position should be removed so that instantaneous reclosing may be initiated by the SX and #14 contacts. The third reclosure must be advanced to the 40 second point or earlier by moving the associated #3 cam spring; the associated #5 cam screw must be relocated to reset Y at 45 seconds. Also, a cam spring must be added to cause #3 contact closure at 50 seconds (or earlier) for reclosure under synchro-verifier control at intermediate lockout, and a #5 cam screw must be added to reset Y before the final lockout or start positions are reached after the final reclosure.

A #4 cam screw must be added to provide a closure at approximately 48 seconds, just prior to the intermediate lockout position. In this scheme the #4 contact functions not only to actuate the final lockout

alarm but also to control intermediate lockout and the following reclosure, via auxiliary relays 79-4X and 79-4Y, upon restoration of line voltage after a permanent fault. If intermediate lockout is desired at a time less than 50 seconds from the start of the reclosing sequence, the cams which actuate the #3 and #4 contacts may be moved to close sooner than the 50 and 48 second points shown in Figure 10. Approximately 10 seconds must separate reclosures to insure that the Y unit has sufficient time to be reset by the #5 cam. Thus, to advance the intermediate lockout time, it is necessary to advance the third reclosure by at least the same amount.

In similar fashion, intermediate lockout must occur at least 10 seconds prior to the start position so that final synchro-check reclosure will not leave the Y unit in the latched position. A #5 cam screw must be added to reset the Y unit as already mentioned and must clear the latch arm before the drum reaches the final lockout position.

The other factory cam settings are satisfactory. In certain styles of the RC relay, cam setting changes similar to those just described may already have been made.

3.8. INSTANTANEOUS RECLOSE OPERATION

Assume a high speed trip for a line fault. This energizes the SX operating coil which is in series with the trip coil 52T. The SX contact along with the closed Y13 and 14 contacts essentially bypass the #3 contact reclosing circuit to initiate immediate reclosing. At the same time the X-Y anti-pump circuit is energized in the conventional manner, picking up the Y unit, opening the Y5 contact to prevent more than one reclosing impulse. In addition, the operation of the anti-pump circuit results in the opening of the Y13 contact. By the time the Y13 opens, the breaker close circuit should be sealed by a 52X contact or equivalent. If the close circuit does not have a seal around Y13 and 14 initiating contact, an internal jumper should be added around the Y13 contact to prevent premature de-energization of the breaker close circuit. Whether Y13 is jumpered or not, the instantaneous reclose circuit is opened soon after the drum moves off the start position since the 14 contact opens at about the 3 second point.

3.9. TIMED RECLOSE OPERATIONS

At 7 seconds a #5 cam screw will reset the Y unit, setting up the circuits for the next reclose try. At 15 seconds, if the bus or the line is dead with the other side hot or if both sides are energized and in synchronism, a reclose will occur should the first reclose be unsuccessful. In any case, the drum will continue to rotate and with the breaker open a similar reclose will occur at 40 seconds if allowed by the CVX or CVE relay or the voltage units. The drum continues to rotate with the breaker open until 48 seconds. If the breaker is open at this point, the #4 contact closure energizes SG relay 79-4X which sets up the RC for a synchronism check reclose whenever the line is restored. The motor continues to run until 50 seconds, then the #3 contact closes. The #3 contact energizes the 79-4Y break contact, then stops the motor. The #3 contact also completes the circuit through the CVX or CVE unit contact so that reclosing will take place when synchronism occurs. The 79-4X break contact in series with the bus and line voltage contacts V_1 and V_2 prevents reclosing at this point for any condition other than synchronism. A 79-4Y contact, connected to an external delay timer, can be used to alarm for this intermediate lockout state.

After the permanent fault is removed from the line and the line is energized from the remote station, the local breaker will close automatically if the line and the bus voltages are in synchronism. This feature eliminates the need for manual restoration at the end of the line protected by this scheme following a permanent fault. After reclosure the 52b contact connected to the negative bus de-energizes the 79-4X and 79-4Y relays so that the motor can be re-energized. The RC then returns to the start position.

If the reserved-synchronism-check reclose at 50 seconds is unsuccessful, the motor moves towards the final lockout position since Y5 de-energizes 89-4X and subsequently 79-4Y. The #4 contact opens at approximately 52 seconds; thus when the #5 cam screw resets Y at about 54 seconds 79-4X is not immediately re-energized by Y-5. An additional #4 contact closure just before final lockout allows 79-4X to be re-energized; a 79-4X contact with external delay timer can provide final lockout alarm. 79-4Y is not energized now since #3 contact opened at about 52 seconds, so the motor continues to run to the final lockout position under #1 contact supervision.

3.10. OPERATION FOR A TRANSIENT FAULT

If the fault has been cleared and reclosing successful prior to the 48 second point the 79-4X unit cannot be energized by the #4 contact due to the open 52b contact, so the motor continues to run through this point to the start position. If the fault is not cleared by high speed relays so that no immediate reclosure occurs the motor will still run to the 15 second point and beyond to provide the voltage or synchronism check reclosures.

3.11. MOTOR-SUPPLY TRANSFER

Where a reliable ac source is not otherwise available or to avoid the need for an inverter, connect the RC motor to bus/line potential. Then the V₁ and V₂ voltage units already available for supervising reclosure may be utilized as shown in Figure 9 to transfer the motor to line side potential upon loss of bus voltage.

3.12. MODIFICATIONS FOR OTHER FEATURES

The relay circuits are sufficiently flexible that any of the above features may be eliminated or modified to suit the individual operational needs. For example, the voltage units may be reconnected or disconnected to set up other voltage logic. Also, synchronism-check reclosing may be eliminated or utilized only on the second and third reclose, with the intermediate lockout feature eliminated. Alternatively, the selective reclosing feature may be eliminated and an immediate unsupervised reclose can be initiated through the #14 contact; or the immediate reclose may be initiated by the 33 contact through the synchronism check or voltage circuits.

4.0 CHARACTERISTICS

The standard rating for the relay is:

Motor	120/240 V, 60 Hz
X and Y units	120/240 V, 60 Hz or 48/125 Vdc
Z Unit (when used)	125 Vdc
Drum Speeds	60-90-180-360 Sec./Rev.

When the motor is to be operated at 240 volts a resistor in the bottom right side is connected in series with the motor coil. Relays are available for operation on 50 hertz. X and Y units can be supplied for a minimum rating of 24 volts dc, or with a 250 volt rating.

4.1. BURDEN DATA

The maximum burdens for the various units of the standard RC relay when energized from a 120 V. 60 cycle supply are listed below:

Contactor Unit (Device 79X)	
Open position	49 VA
Closed position	33 VA
Solenoid Unit (Device 79Y)	
Open position	151 VA
Closed position	84 VA
Synch, Motor Device 79M) 8.5 VA	
Auxiliary Unit (Device 79Z)	
When used	
Closed position	10.5 VA at 120 V
.	60 hertz
.	3.5 watts at
.	125 V dc

The burdens of the X and Y units occur only momentarily during the reclosing cycle but the motor is energized throughout the reclosing cycle. The X and Y units can be energized for a 1 minute period and the motor for a 15 minute period without injury. The Z unit can be energized continuously.

5.0 SETTINGS

No settings are necessary unless factory settings do not meet the application requirements. The factory settings are for three reclosures; immediate, 15 and 45 seconds, with a drum revolution in 60 seconds. Contact #4 is set to close in the lockout position. Contact #14 is set to close in the start position for instantaneous trip lockout after the first reclosure. The standard relay is shipped with the X and Y coil and motor coil resistors connected. With these connections the X and Y coils may be used at 125 volts dc or 240 volts ac; the motor, at 240 volts ac.

5.1. COIL RESISTOR RECONNECTION

If the X and Y coils of the standard relay are to be used in 48 volts dc or 120 volts ac, the X and Y coil resistor must be bypassed. If the motor is to be energized at 120 volts ac, the motor coil resistor must be bypassed.

5.2. DRUM SPEED

To change the drum speed, loosen the clamping screw at the edge of the drum speed dial, depress the push rod on the drum, and rotate the motor and gear assembly to the desired speed position, by pushing on one or more of the posts between the motor and gear mounting plates. Then tighten the clamping screw. Select the fastest drum speed which will accommodate the desired reclose timing.

5.3. RECLOSE SEQUENCE

The #3 cam springs (which initiate reclosing) can be set at any point from the start position, to the 50th scale division, by loosening the cam spring screw and sliding the cam to the desired position. The cams may not be spaced closer than 10 scale divisions. If a closer spacing is used there is not sufficient time to open the #3 contact and then unlatch the Y unit. Thus, the maximum number of reclosures is six at the 0, 10, 20, 30, 40 and 50 scale division points. A cam spring may not be placed past the 50th scale division. Otherwise insufficient time is available to allow the Y unit to unlatch and #5 cam screw to travel clear of the latch before the lockout position. A thin headed screw is located in the #3 groove near the start position. This screw acts as a stop to prevent a #3 cam spring setting which would close the #3 contact with the drum in the locked position.

After the #3 cam springs have been set, the #5 cam screws must be located to unlatch the Y unit after each #3 contact closure. The #5 screws should not rotate the Y unit latch arm until the #3 contact has opened. In addition, the #5 cam screws must be clear of the Y unit latch arm before the next #3 contact closure.

Hardware is shipped with each relay to provide additional cams for applications requiring more cams than are used with the factory settings.



If the circuit breaker does not have a latch check switch, reclosing should be delayed by use of the Y6 contact either to directly energize the close circuit, or to energize an external auxiliary relay.

Using the Y6 contact will delay reclosing about 2 cycles after 52bb contact closes with X and Y energized by ac voltage; 4 cycles, with X and Y energized by dc voltage.

6.0 INSTALLATION

The relays should be mounted on switchboard panels or their equivalent in a location free from dirt, moisture, excessive vibration and heat. Mount the relay vertically by means of the rear mounting stud or studs for the type FT projection case or by means of the four mounting holes on the flange of the semi-flush type FT case. Either the stud or the mounting screws may be utilized for grounding the relay. External toothed washers are provided for use in the locations shown on the outline and drilling plan to facilitate making a good electrical connection between the relay case, its mounting screws or studs, and the relay panel. Ground Wires should be affixed to the mounting screws or studs as required for poorly grounded or insulating panels. Other electrical connections may be made directly to the terminals by means of screws for steel panel mounting or to the terminal stud furnished with the relay for thick panel mounting. The terminal stud may be easily removed or inserted by locking two nuts on the stud and then turning the proper nut with a wrench.

For detail information of the FT case refer to I.L. 41-076.

7.0 ADJUSTMENTS AND MAINTENANCE

The proper adjustments to insure correct operation of this relay have been made at the factory. Readjustment after receipt by the customer will be necessary only as required by the reclosing cycle requirements and the supply voltages of a particular application as described under "Section 5, Settings." In reassembling the relay after repairs, or in checking the adjustments at regular maintenance periods, the instructions below should be followed.

7.1. Routine Check

The factory settings of the standard relay are:

Coil Resistors in series with X and Y, and motor

X and Y Rating	125 volts dc/240 volts ac
Motor Rating	240 volts 60 cycles
Motor Speed	1 revolution in 60 seconds
Control Settings	See Figure 5

The following checks may be performed to determine if the relay, as received from the factory, is in serviceable condition.

Energize the X and Y coils with 50% of the above ac ratings (or 80% of the dc rating). The lower ratings may be used by bypassing the coil resistor or resistors. Energize the motor coil and the Z coil, if used, at 80% of rating. See that X and Y pick up positively and that proper contact action is obtained. The correct adjustment of the X unit is as follows: Set the distance from the front end of the armature mold to the metal yoke to 9/16". Set the X8 contact gap at 3/32" and the X9 gap at 5/32". With the above adjustment X9 should have a minimum of 1/32" contact follow. Y unit contact action should be as detailed under the section, "2. Construction".

Determine the time required for one drum revolution. The time in seconds should correspond to the drum speed dial marking $\pm 3.5\%$. Observe drum cam action during this interval or by manually rotating the drum with the push rod depressed.

7.2. ROUTINE MAINTENANCE

All contacts should be periodically cleaned with a fine file. A contact burnisher S#182A836H01 is recommended for this purpose. The use of abrasive material for cleaning contacts is not recommended, because of the danger of embedding small particles in the face of the soft silver and thus impairing the contact.

7.3. MOTOR LUBRICATION

The motor bearing contains a supply of special lubricant sufficient for three to five years service. This lubricant does not congeal at low temperatures and permits satisfactory operation of the motor at ambient temperatures of 30°F to -40°F, such as sometimes may occur in outdoor installations. This oil is available in 1/4 ounce bottles as S#1724231.

To lubricate the motor, withdraw the drum speed dial assembly after removing the clamping screw and the black screws. Then, gently work the motor and gear assembly loose from the rear chassis mounting plate and lower it under the front chassis mounting plate. (When used, the Z unit must be removed.) Remove the gear plate of the motor and gear assembly and, then, the knurled oil cap. Saturate the wool with S#1724231 oil. Reassemble.

8.0 RENEWAL PARTS

Repair work can be done most satisfactorily at the factory. However, interchangeable parts can be furnished to the customers who are equipped for doing repair work. When ordering parts, always give the complete nameplate data.

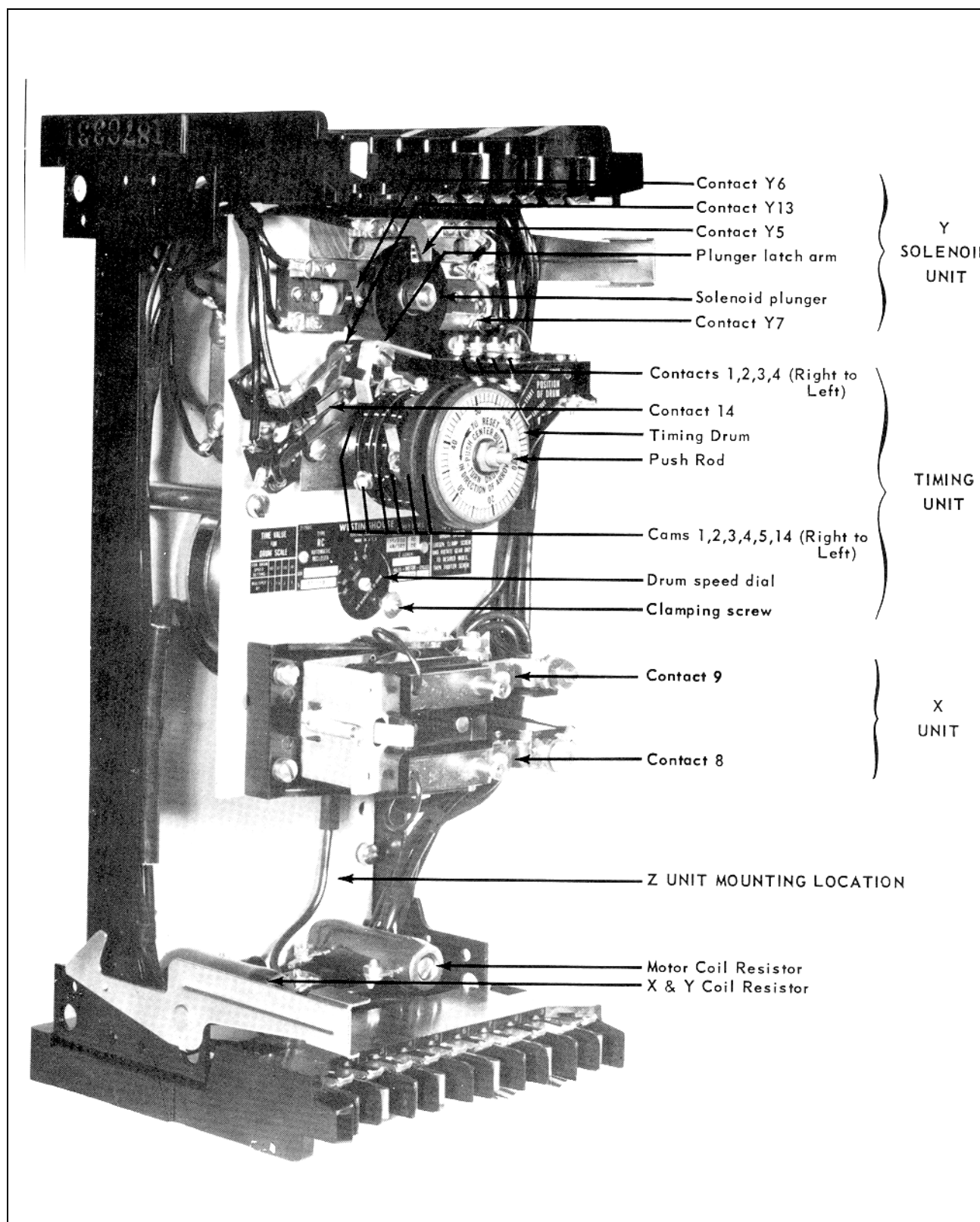

Figure 1. Type RC Relay, without Z Unit, without Case

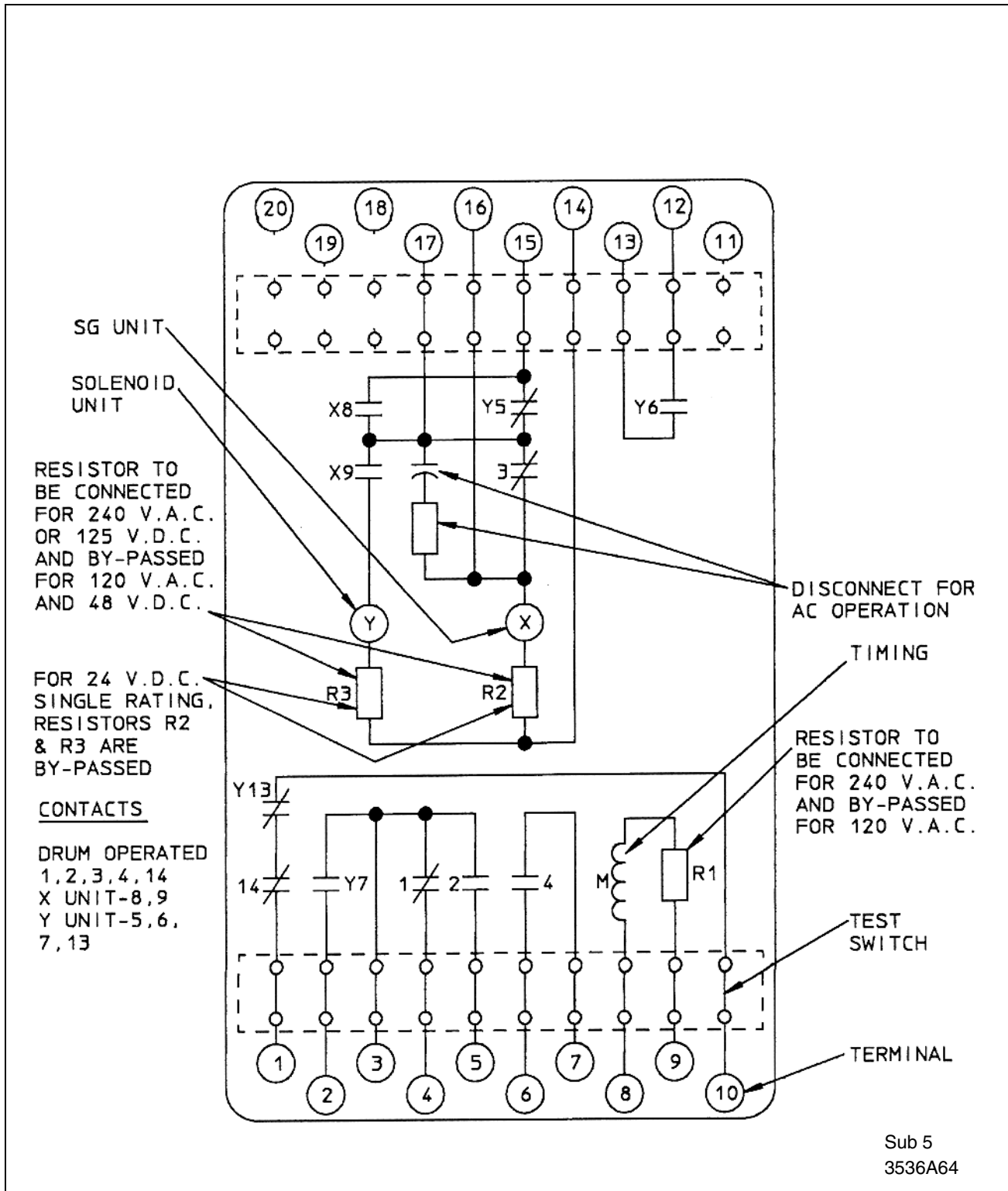

Figure 2. Internal Schematic of the RC Relay, without Z Unit, in Type FT-32 Case

* Denotes Change

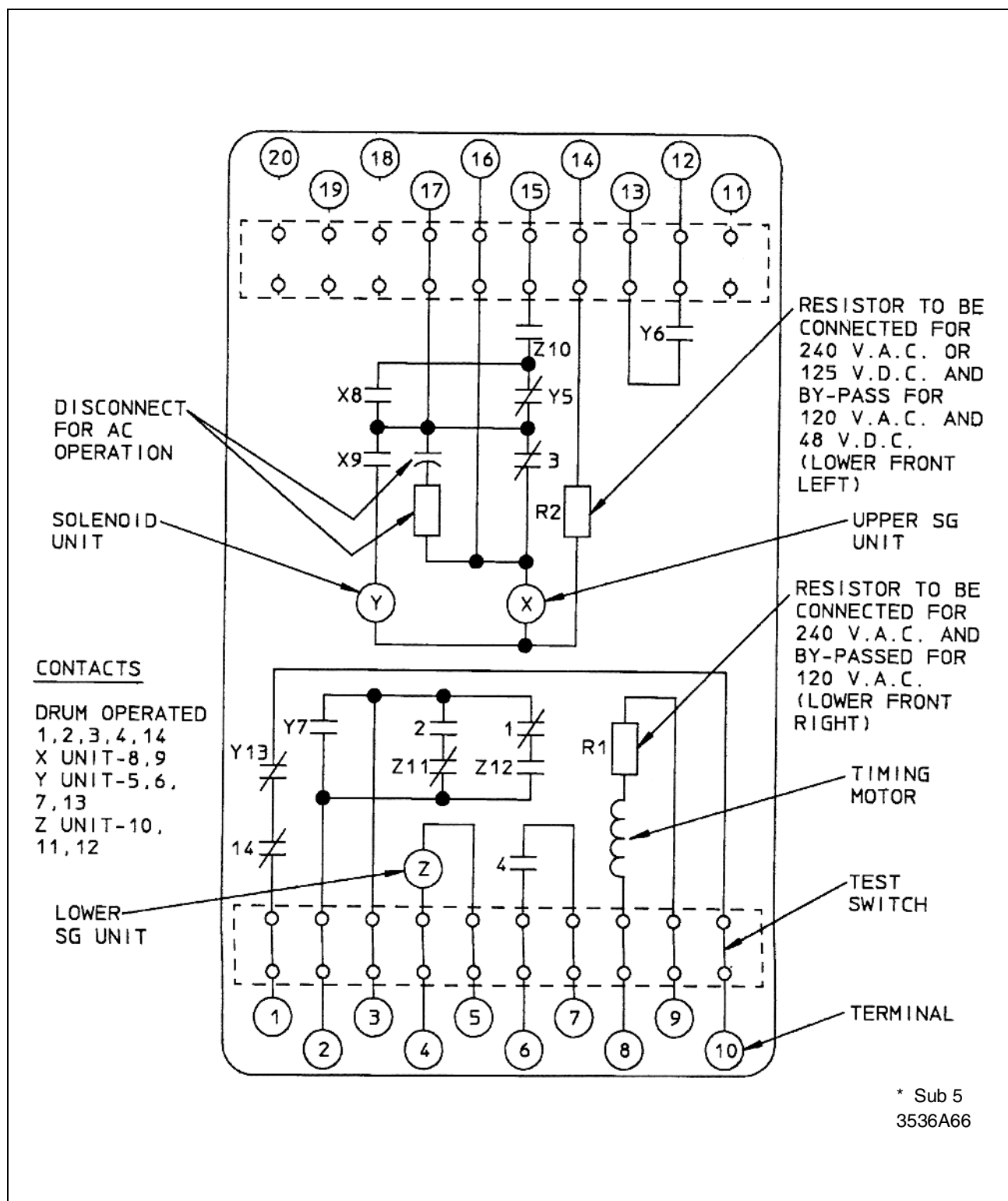
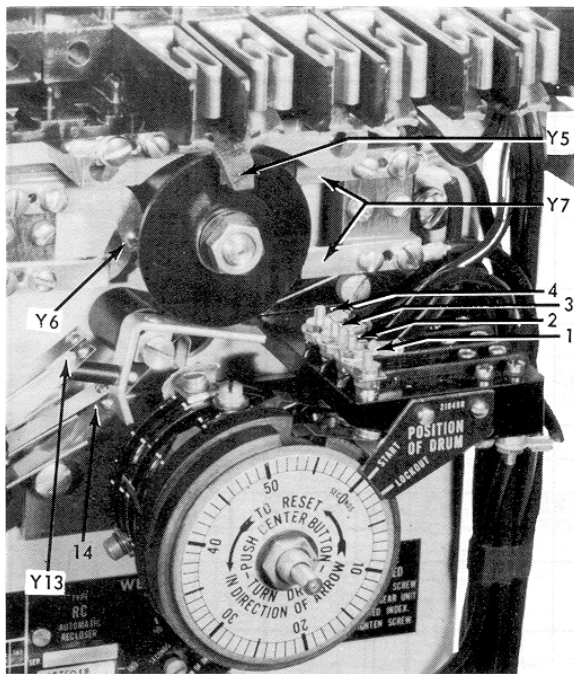
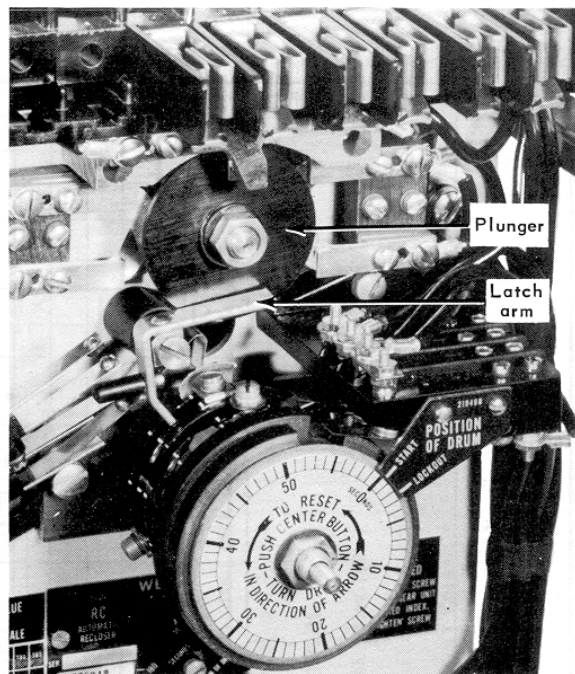

Figure 3. Internal Schematic of the RC Relay, with Z Unit, in Type FT-32 Case

* Denotes Change



(A) Start Position – Y Unit Reset



(B) During Immediate Reclosing – Y Unit Reset to Latch

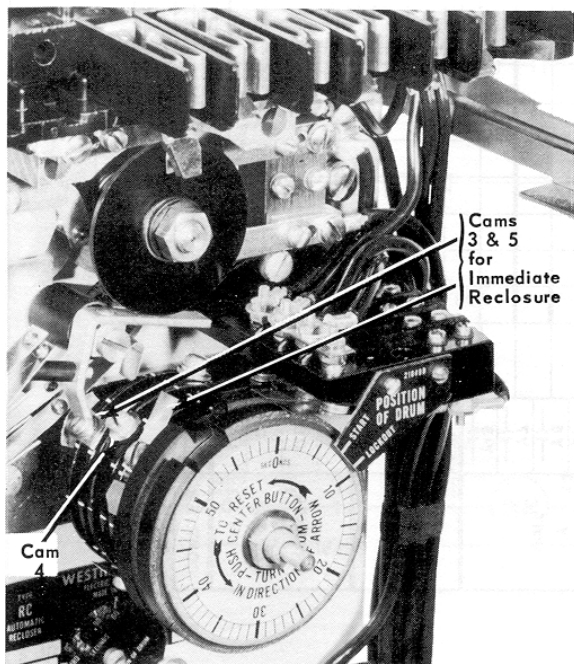

(C) Preparing for Second Reclosure

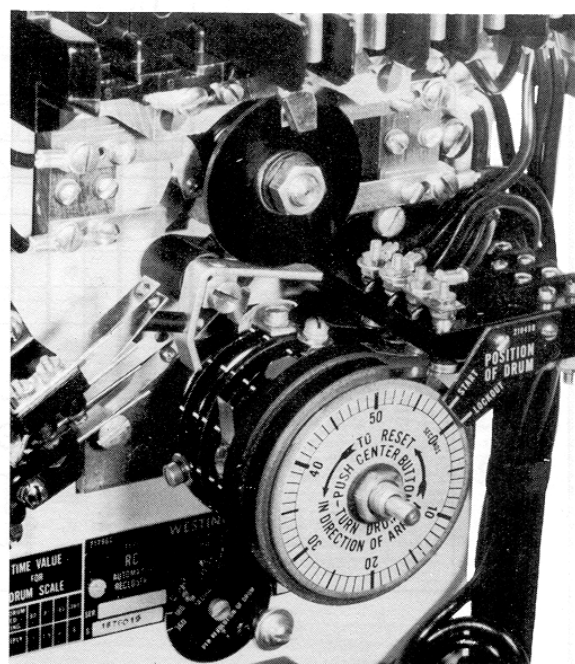

(D) Lockout Position

Figure 4. Cam and Y Unit Contact Positions

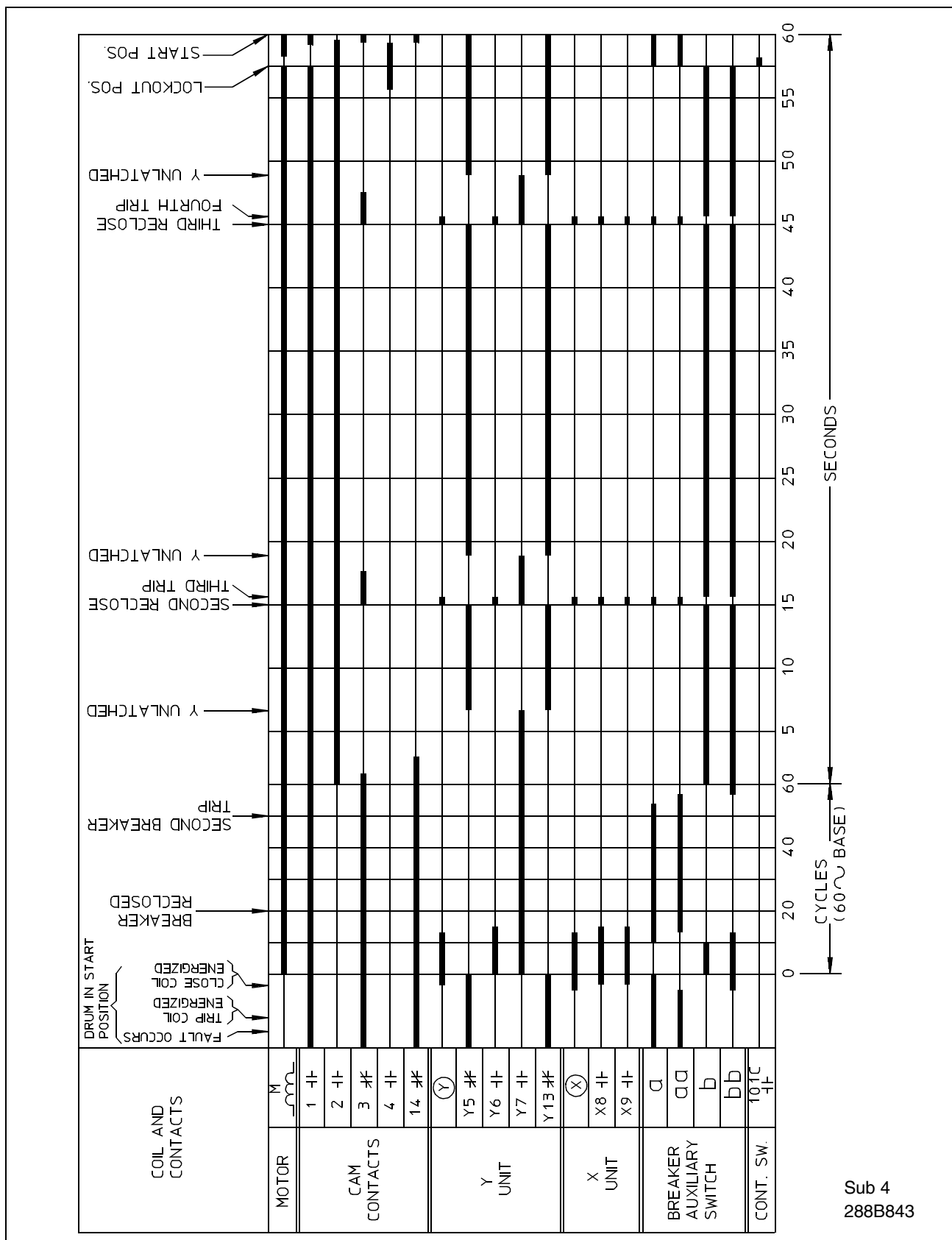

Figure 5. Contact Position Development – One Immediate and Two Time Delay Reclosures. Heavy Line Indicates Contact Closed or Coil Energized. One Revolution in 60 Seconds. Permanent Fault. Instantaneous Trip Lockout After First Reclosure

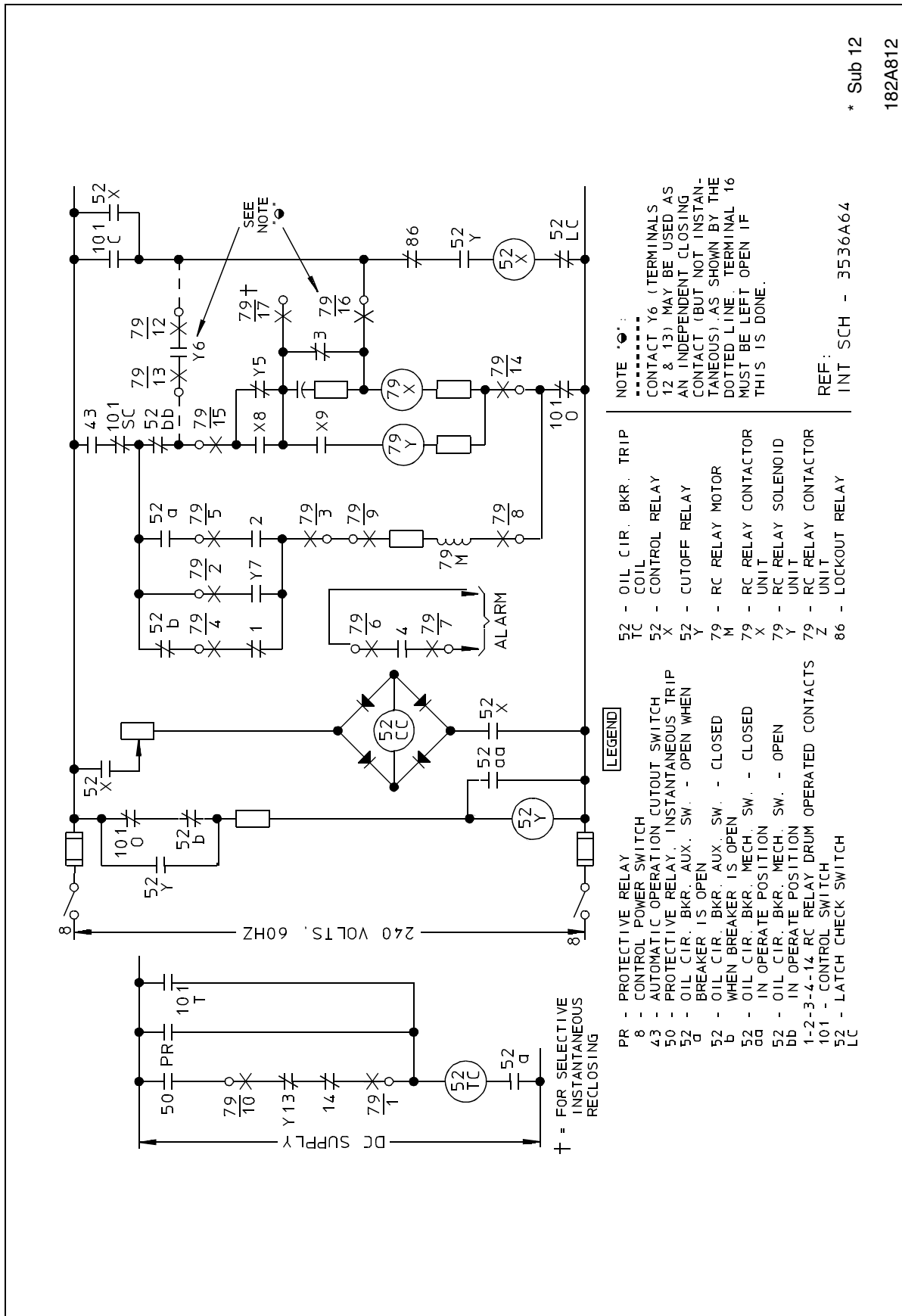

Figure 6. External Schematic of the Type RC Relay, without Z Unit, with AC Breaker Control Circuit

*Denotes Change

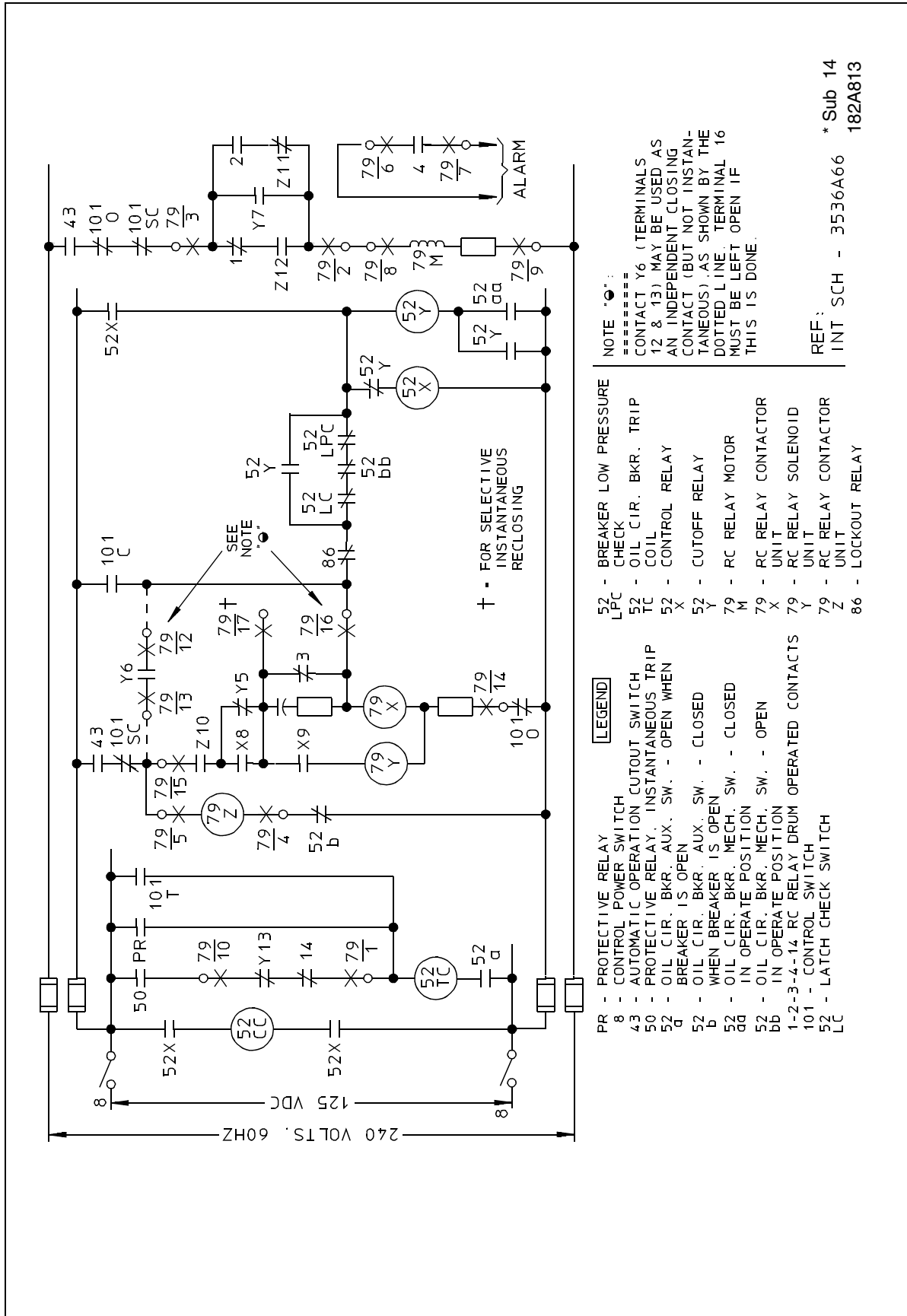

Figure 8. External Schematic of the Type RC Reclosing Relay, With Z Unit used in DC Breaker Control Circuit

* Denotes Change

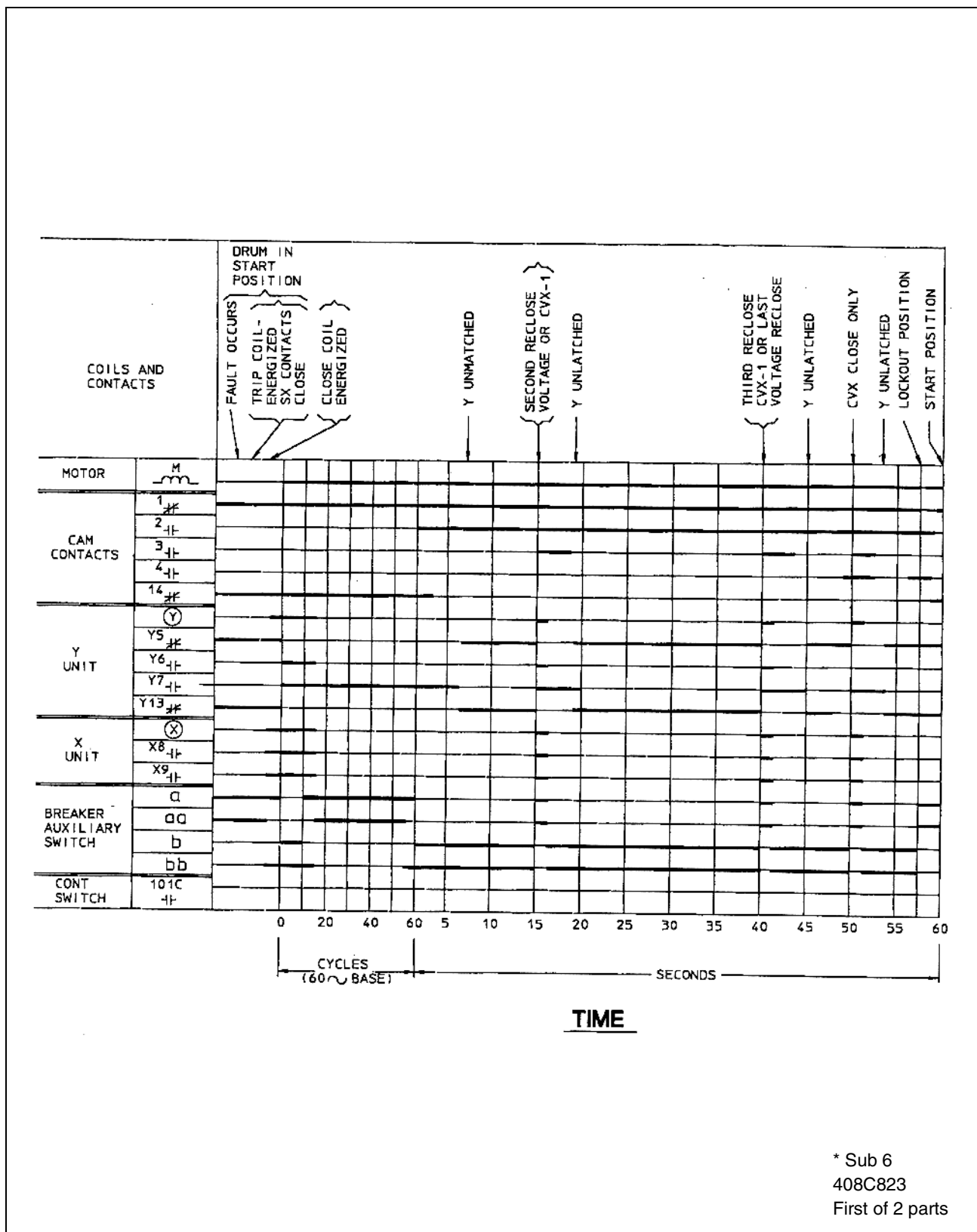
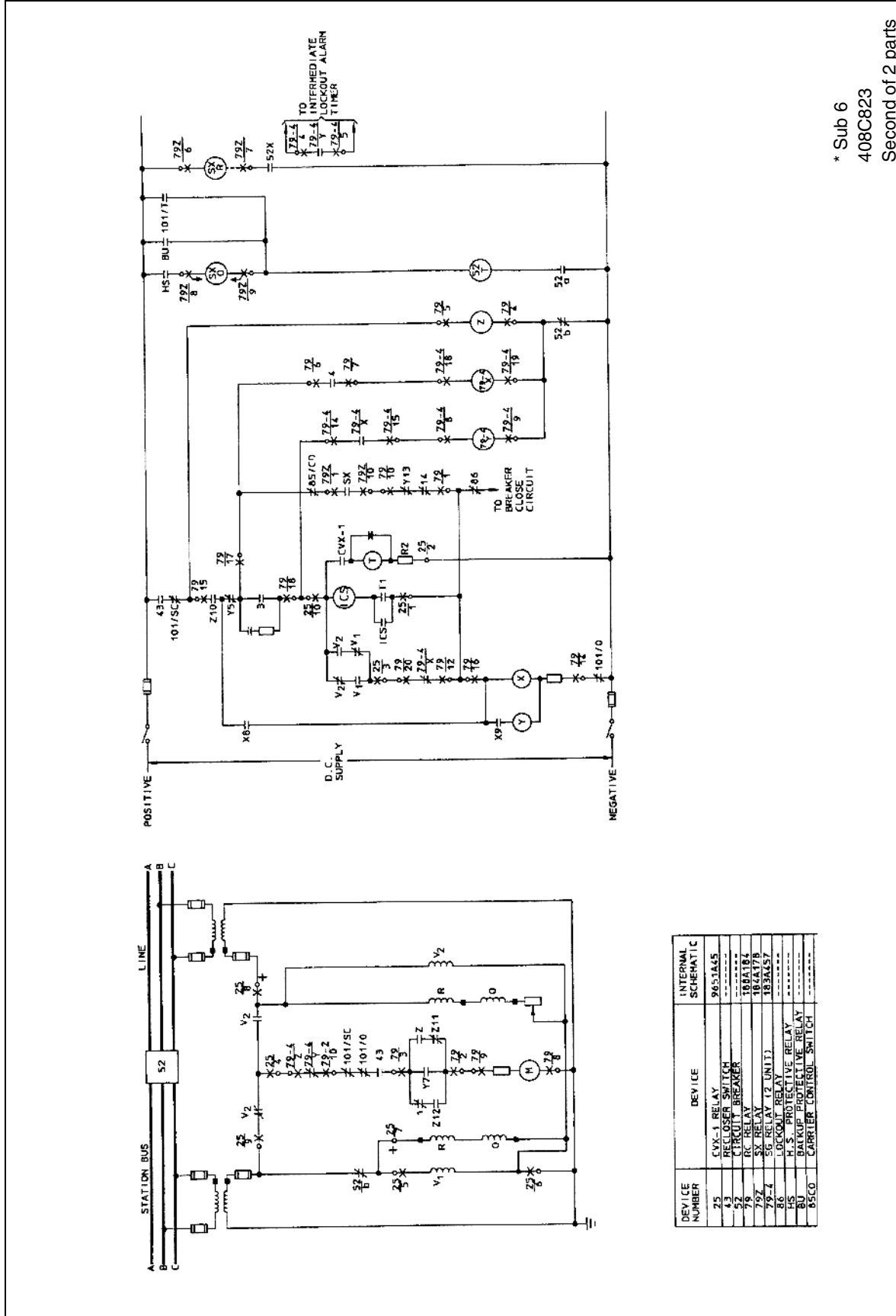

Figure 9. External Schematic for RC Relay with CVE-1 Synchro-Verifier Relay, Intermediate Lockout and Alarms

* Denotes Change



* Sub 6
408C823
Second of 2 parts

Figure 10. Contact Position Development – RC Relay with CVX-1 Synchro-Verifier Relay Supervision. Heavy Line Indicates Contact Closed or Coil Energized. One Revolution in 60 Seconds. Permanent Fault.

* Denotes Change

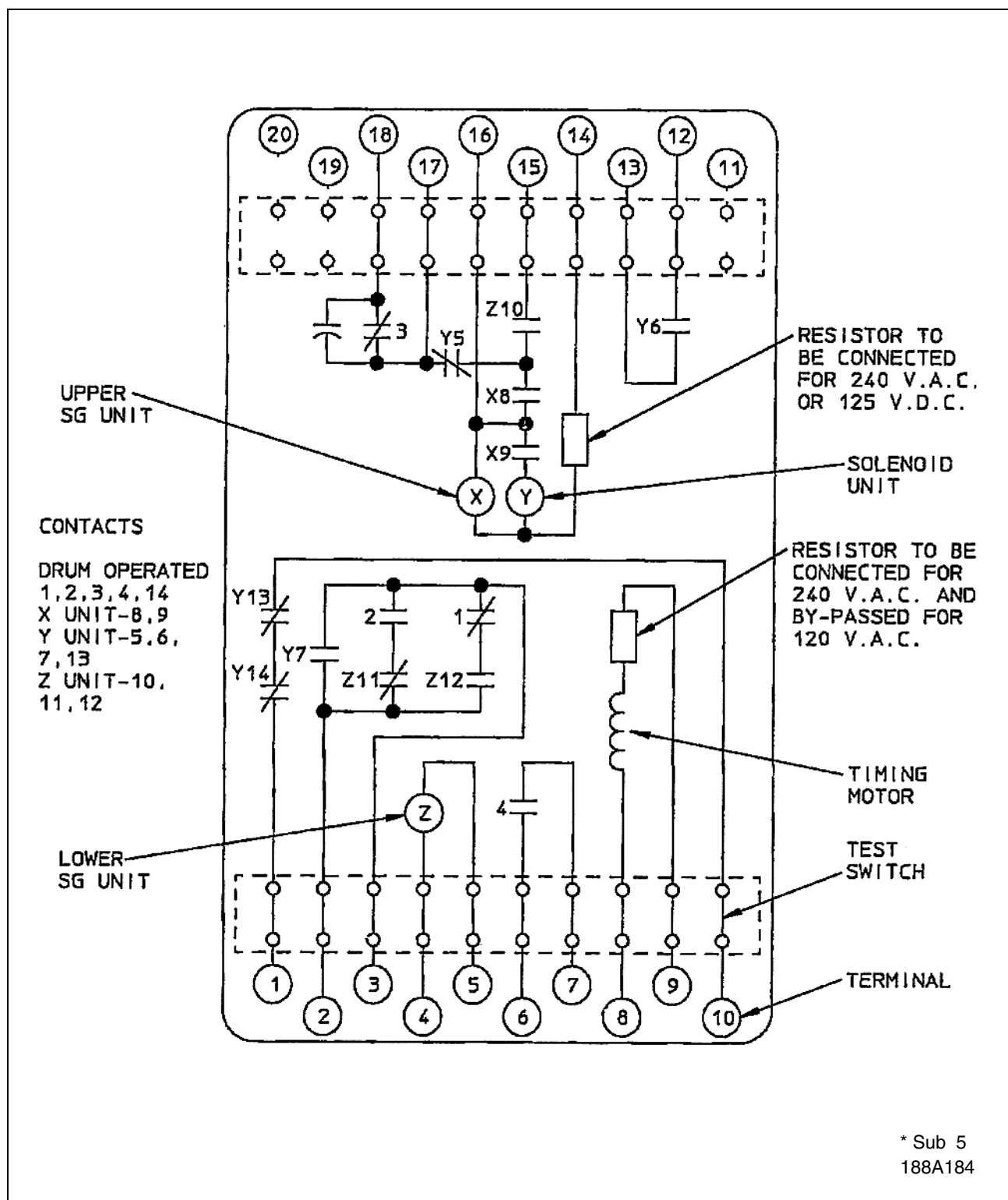

Figure 11. Internal Schematic of the RC Relay, with Z Unit, and #3 Contact Connected in Terminals, in Type FT-32 Case

* Denotes Change

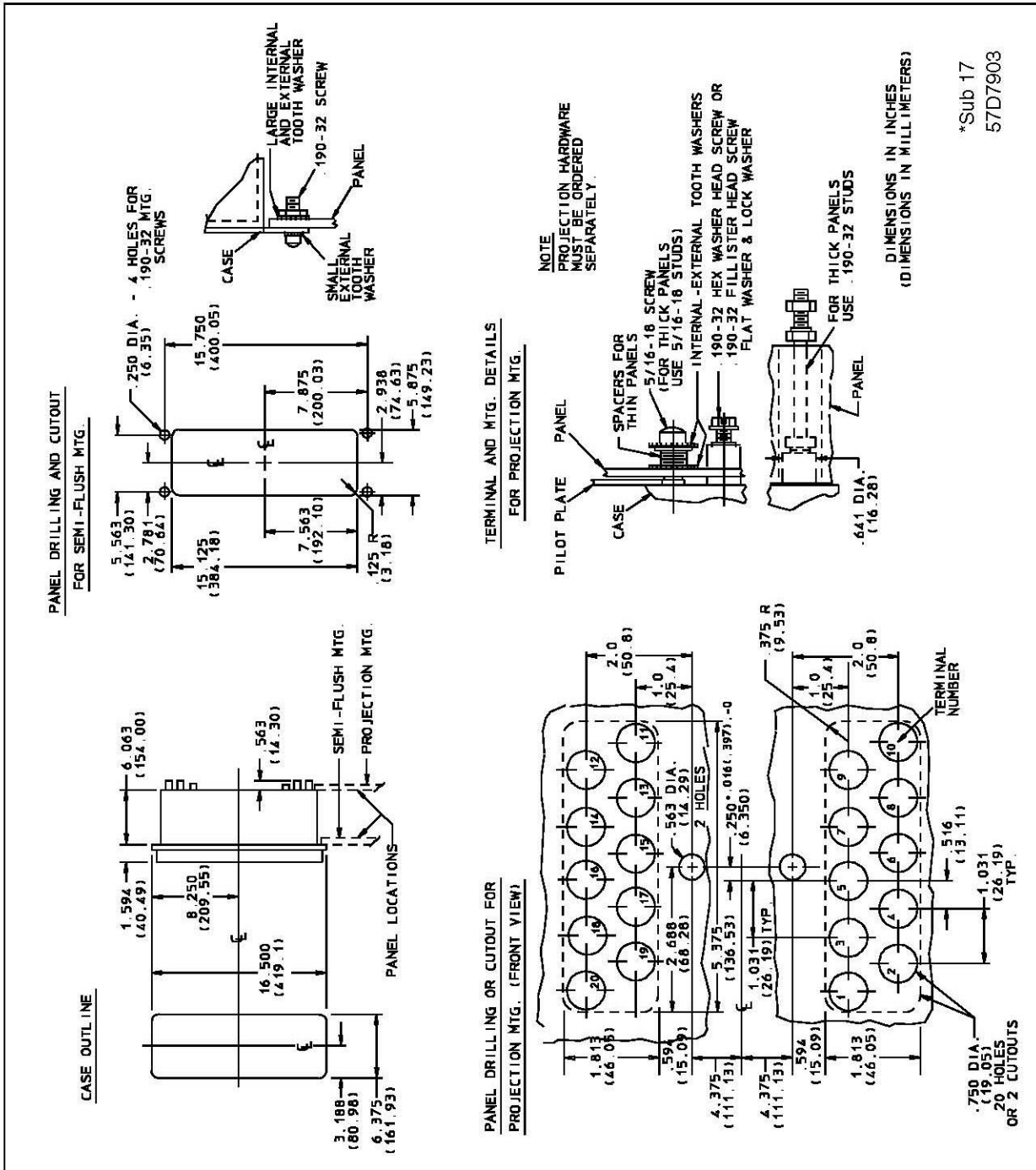

Figure 12. Outline and Drilling Plan for the Type RC Relay in the Type FT-32 Case

* Denotes Change



ABB Inc.
 4300 Coral Ridge Drive
 Coral Springs, Florida 33065
 Telephone: +1 954-752-6700
 Fax: +1 954-345-5329
 www.abb.com/substation automation