

Installation
and maintenance manual

Softstarters

Type SSM
Medium voltage
200 – 7,500 HP



Chapter 1 - Introduction

This chapter is an introduction to the ABB's **SSM** reduced voltage solid state starter for medium voltage AC motors. It describes the basic configuration, operation and unit features. It is highly recommended that new users read this section thoroughly to gain a basic understanding of the starter system before attempting to start up a unit. If you are already familiar with the **SSM** starter, you may begin setup procedures immediately by proceeding to Chapter 2 – Installation.

1.1 Overview

The standard **SSM** soft starter is a complete NEMA Class E-2 motor controller designed for the starting, protection and control of AC medium voltage motors. It contains the motor disconnect switch, motor circuit fuses, control power transformer, a line isolation contactor, SCR stack assemblies, a bypass contactor, low voltage controls and motor terminal blocks. An optional "soft start only" version is also available which is supplied without the control power transformer, the disconnect switch and line isolation contactor. (The soft start only model must be used with a customer supplied, mechanically interlocked line start panel).

1.2 Specifications

Type of Load	Three phase AC induction motors or synchronous motors (see addendum)
AC Supply Voltage	2300, 3300, 4160, 7200 VAC +10% to -15%
Nominal HP Ratings	2300V 200 HP - 2500HP 3300V 200HP - 3000HP 4160V 250HP - 5000HP 6000/7200V 300HP - 7500HP 11 - 15KV 800HP - 15000HP (See 11 - 15kV manual)
Unit Overload Capacity (Percent of motor FLA)	125% - Continuous 500% - 60 seconds 600% - 30 seconds 1 Cycle: up to 14x FLA (internally protected by the programmable short circuit)
Frequency	50 or 60Hz, ± 2 Hz hardware selectable
Power Circuit	6 SCRs, 12 SCRs, 18 SCRs (model dependent)
SCR Peak Inverse Voltage Ratings	6500V - 21000V (model dependent see Table 1 on page 4)
Phase Insensitivity	User selectable phase sequence detection
Transient Voltage Protection	RC snubber dv/dt networks (one per SCR power module)
Cooling	Convection fan for NEMA1 or NEMA12 units >400Amps
Bypass Contactor	Line rated vacuum contactor included as standard in all enclosed units
Ambient Condition Design	Chassis units: 0° to 50 °C (32° to 122°F) Enclosed units: 0° to 40°C (32° to 104°F) (optional - 20° to 50° C with heaters) 5 - 95% relative humidity 0 - 3300 ft. (1000m) above sea level without derating
Control	2 or 3 wire 120VAC (customer supplied) CPTs are included on standard units (optional on soft start only models)
Auxiliary Contacts	Multiple: Form C (contacts), rated 4 Amps, 240VAC max. 8 Relays (4 programmable): Form C contacts Fault Indicator: Form C contact
BIL Rating	2300V - 7200V 60KV 11000 - 15000V 110KV (see 11 - 15kV manual)
Approvals	UL Listed, Canadian UL (cUL) Listed thru 4160V (higher ratings pending)

Chapter 1 - Introduction

1.2 Specifications (continued)

Advanced Motor Protection	
Two Stage Electronic Overload Curves	Starting: Programmable for Class 5 through 30 Run: Programmable for Class 5 through 30 when "At-Speed" is detected.
Overload Reset	Manual (default) or automatic
Retentive Thermal Memory	Overload circuit retains thermal condition of the motor regardless of control power status. Unit uses real time clock to adjust for off time.
Dynamic Reset Capacity	Overload will not reset until thermal capacity available in the motor is enough for a successful restart. Starter learns and retains this information by monitoring previous successful starts.
Phase Current Imbalance Protection	Imbalance Trip Level: 5 - 30% current between any two phases Imbalance Trip Delay: 1 -20 seconds
Over Current Protection (Electronic Shear Pin)	Trip Level: 100 - 300% of motor FLA Trip Delay: 1 - 20 seconds
Load Loss Trip Protection	Under Current Trip Level: 10 -90 % of motor FLA Under Current Trip Delay: 1 - 60 seconds
Coast Down (Back Spin) Lockout Timer	Coast Down Time Range: 1 - 60 minutes
Starts-per-hour Lockout Timer	Range: 1 - 6 successful starts per hour Time between starts: 1 - 60 minutes between start attempts
Programmable Outputs	
Type / Rating	Form C (DPDT), Rated 4 amps 240 VAC max, (960 VA)
Run Indication	Programmable
At Speed Indication	Programmable
Acceleration Adjustments	Programmable Ramp Types: Voltage or Current Ramp (VR or CR) Starting Torque: 0 - 100% of line voltage (VR) or 0 - 600% of motor FLA (CR) Ramp Time: 1 to 120 seconds Current Limit: 200 - 600% (VR or CR)
Dual Ramp Settings	4 Options: VR1+VR2; VR1+CR2; CR1+CR2; CR1+VR2 Dual Ramp Control: Ramp 1 = Default Ramp 2 = selectable via dry contact input
Deceleration Adjustments	Begin Decel Level: 0 - 100% of line voltage Stop Level: 0 to 1% less than Begin Decel Level Decel Time: 1 - 60 seconds
Jog Settings	Voltage Jog: 5 - 75%
Kick Start Settings	Kick Voltage: 10 - 100% Kick Time: 0.1 - 2 seconds
Fault Display	Shorted SCR, Phase Loss, Shunt Trip, Phase Imbalance Trip, Overload, Overtemp, Overcurrent, Short Circuit, Load Loss, Undervoltage or Any Trip
Lockout Display	Coast Down Time, Starts Per Hour, Time Between Starts, and Any Lockout
Event History	
Up to 60 Events	Data includes cause of event, time, date, voltage, power factor and current for each phase and ground fault current at time of event

Chapter 1 - Introduction

1.2 Specifications (continued)

Metering Functions	
Motor Load	Percent of FLA
Current Data	A, B, C Phase Current, Avg Current, Ground Fault (Option)
Thermal Data	Remaining thermal register; thermal capacity to start
Start Data	Avg Start Time, Avg Start Current, Measured Capacity to start, time since last start
RTD Data (Option)	Temperature readings from up to 12 RTDs (6 stator RTDs)
Voltage Metering	kW, kVAR, PF, kWh
Serial Communications	
Protocol	Modbus RTU
Signal	RS-485, RS-422 or RS232
Network	Up to 247 devices per mode
Functionality	Full operation, status view, and programming via communications port
Operator Interface	
LCD Readout	Alpha numeric LCD display
Keypad	8 function keys with tactile feedback
Status Indicators	12 LEDs include Power, Run, Alarm, Trip, Aux Relays
Remote Mount Capability	Up to 1000 circuit-feet from chassis (use twisted, shielded wire & power source)
Clock and Memory	
Operating Memory	SRAM loaded from EEPROM at initialization
Factory Default Storage	Flash EPROM, field replaceable
Customer Settings and Status	Non-volatile EEPROM, no battery backup necessary
Real Time Clock	Lithium ion battery for clock memory only

Chapter 1 - Introduction

1.3 Design Features

The standard **SSM** configuration is a complete NEMA Class E-2 motor controller which includes the following features:

- **Disconnect Switch:**

A “Fault Make - Load Break” rated disconnect switch is provided in the incoming power section of the starter assembly. The maximum design voltage is 5KV for 2300 - 4160V units and 7.2KV for 6600 - 7200V units.

The disconnect can be padlocked in the “Open” position. The disconnect compartment door cannot be opened while the disconnect is closed, (i.e. system power is on); likewise the disconnect cannot be closed when the incoming power section door is open. Associated doors in sections containing medium voltage are interlocked with the incoming power section door, by either direct mechanical means such as guillotine switches, or by use of Kirk-key interlock mechanisms.

A viewing window in the Main Incoming Power Compartment allows visual inspection of the disconnect blade status without opening the door. A separate knife arm on the disconnect bonds the mechanism to the ground when the switch is fully open.

- **Power Fuses:** As a NEMA Class E2 controller, current limiting primary power fuses are provided for each incoming phase.

Typically the fuses are ANSI class “R” for units rated up to 7200. The fuses are sized according to motor locked rotor current and are coordinated with the solid state overload relay. The fuse and overload coordination is designed to allow the controller and contactor to clear low and medium level faults. This prevents exceeding the contactor interrupt ratings. Fuses interrupt high level faults that exceed the contactor interrupt ratings. Fuse holders include blown fuse indicators (wired to the isolation contactor circuit) to disconnect all three phases if any one of the fuses clears (see section 2.7).

- **SCR Power Modules:** For each phase, the SCRs are **matched** devices arranged in inverse parallel pairs and in series strings as indicated in the chart to facilitate sufficient PIV ratings for the applied voltage.

- **RC Snubber Networks:** provide Transient Voltage Protection for SCR Power Modules in each phase to avoid dv/dt damage.

- **Firing Circuit:** The SCRs are gated (turned on) using a Sustained Pulse Firing Circuit. This circuitry is amplified and isolated from the control voltage by means of fiber optics for current and ring transformers.

- **Contactors:** Vacuum contactors are provided for both In-Line Isolation and SCR Bypass. The contactor voltage ratings are: 5KV for 2300 -4160V units and 7.2KV for 6000 - 7200V units.

A sequencing feature controls the contactors. Under normal operating conditions this ensures that both contactors make and break under no-load conditions to maximize contactor life. Vacuum contactors are rated for the maximum starting requirement of the unit design. The Bypass Contactor is rated to be capable of emergency start.

- **Soft Start Only Option:** The **SSM** is also offered in an optional “Soft Start Only” package for use in retrofitting behind an existing customer supplied line start

200 & 400 Amps Units			
Voltage	Series Pairs	Total Number of SCRs	PIV Rating
2300 V	0	6	6500 V
3300 / 4160 V	2	12	13000 V
6000 - 7200 V	3	18	19500 V

600 Amps Units			
Voltage	Series Pairs	Total Number of SCRs	PIV Rating
2300 V	2	12	7000 V
3300 / 4160 V	4	24	14000 V
6000 - 7200 V	6	36	21000 V

Unit PIV Ratings
Table 1

Chapter 1 - Introduction

controller. In this configuration, **the Disconnect Switch, Fuses and Line Isolation Vacuum Contactor and CPT are NOT included in the SSM** “Soft Start Only” unit, so proper interlocking of sections containing medium voltage becomes the installer’s responsibility.

All retrofit “Soft Start Only” packages must be used with complete line isolation using a contactor or other “air-gap” device. The Optional “Soft Start Only” unit includes overload protection in normal operation mode and will sequence the isolation contactor, so all logic control should be done at the **SSM** control unit. Avoid turning the **SSM** on and off using the isolation device. 120V control power must be supplied (minimum of 750VA) to the control board indicating the line isolation contactor status. (CPT is not included)

1.4 Structure and Power Bus

The **SSM** is a heavy duty design. Special consideration has been given to the enclosure and unit design to ensure that it is suitable for most applications and environments.

- **Structure:** Steel enclosure (with a minimum thickness of 11 gauge) form a rigid free-standing dead front structure. The enclosure assembly is NEMA / EEMAC type 12 with full gasketing to protect all internal components from contamination.
- **Sections:** The structure is divided into three (3) isolated compartments:

The **Main Incoming Power Compartment** houses the main disconnect switch and horizontal power bus bars (if provided). A viewing window provides clear indication of the switch position without opening the compartment. Top or side cable entry can be made with minimum bending.

One or more **Starter Power Compartments** contain the fuses, vacuum contactors, SCR power modules, instrument transformers and all other medium voltage devices. Adequate room is provided for motor lead connections to be made with minimum conductor bend.

A **Low Voltage Control Compartment** houses the digital microprocessor controller and LCD keypad operator interface, along with any other low voltage devices. This allows the operator to make adjustments without exposure to the line voltages.

Compartment doors are rolled and formed to be capable of containing maximum fault forces. Doors open a minimum of 120° and are designed to stay open during servicing or testing.

Removable conduit entry plates are provided in the top and bottom of the enclosures to facilitate drilling and punching of conduit holes without exposing the equipment to contamination from metal debris.

- **Enclosure Finish:** The enclosure is suitable for use in non-corrosive environments. The paint is ANSI 61 gray polyurethane powder over a zinc phosphate pre-treatment with a minimum thickness of 2 mil. 11 gauge steel is used in all enclosures. All NEMA 12 units have top and bottom entrance plates.
- **Lifting Provisions:** Eyes or angles capable of supporting the maximum weight of each shipping split are provided on the top of the enclosure.
- **Power Bus:** Optional main horizontal phase bus bars can be configured to extend the entire length of the starter lineup. Bus bar material is tin-plated or silver-plated copper. All bus

Chapter 1 - Introduction

ratings are per UL Standard 347.

- **Bracing:** Bus bars are braced with non-tracking fire resistant non-hygroscopic insulation supports and have a minimum fault current rating of 78,000 Amps.
- **Connections:** All bus connections use 2 bolts minimum, with Belleville spring washers to ensure tightness. Splice kits for each shipping split are included, along with specific installation instructions.
- **Ground Bus:** A continuous ground bus bar with a minimum rating of 400 Amps extends the entire length of the starter near the bottom of each enclosure. A grounding strap connects each vertically adjacent compartment and also ties the grounding arm of the disconnect switch to the main ground bus bar (*see section 2.11*).
- **Seismic Qualifications:** The entire starter assembly, when properly installed, withstands vertical and horizontal accelerations typical of seismic Zones 1 through 4 as defined in the UBC. The assembly will not overturn or show significant lateral movement, but cannot be expected to continue operating during, or after, a seismic event.

1.5 Theory of Operation

The power of the **SSM** is in the CPU, a microprocessor based protection and control system for the motor and starter assembly. The CPU uses Phase Angle Firing of the SCRs to apply a reduced voltage to the motor, and then slowly and gently increases torque through control of the voltage and current until the motor accelerates to full speed. This starting method lowers the starting current of the motor, reducing electrical stresses on the power system and motor. It also reduces peak starting torque stresses on both the motor and load mechanical components, promoting longer service life and less downtime.

Acceleration: The **SSM** comes standard with several methods of accelerating the motor so that it can be programmed to match almost any industrial AC motor application.

The factory default setting applies a **Voltage Ramp** with **Current Limit** as this has been proven the most reliable starting method for the vast majority of applications. Using this starting method, the Initial Torque setting applies just enough voltage to the motor to cause the motor shaft to begin to turn. This voltage is then gradually increased over time (as per the Ramp Time setting) until one of three things happen: the motor accelerates to full speed, the Ramp Time expires or a Current Limit setting is reached.

If the motor accelerates to full speed before the ramp time setting has expired, an automatic Anti-Oscillation feature will override the remaining ramp time and full voltage will be applied. This will prevent any surging or pulsation in the motor torque, which might otherwise occur due to the load not being fully coupled to the motor when operating at reduced voltage and torque levels.

If the motor has not reached full speed at the end of the ramp time setting, the current limit setting will proportionally control the maximum output torque. Feedback sensors in the **SSM** provide protection from a stall condition, an overload condition or excessive acceleration time.

The Current Limit feature is provided to accommodate installations where there is limited

Chapter 1 - Introduction

power available (for example, on-site generator power or utility lines with limited capacity). The torque is increased until the motor current reaches the pre-set Current Limit point and it is then held at that level. Current Limit overrides the ramp time setting so if the motor has not accelerated to full speed under the Current Limit setting, the current remains limited for as long as it takes the motor to accelerate to full speed.

When the motor reaches full speed and the current drops to running levels, the **SSM** detects an At-Speed condition and closes the Bypass Contactor. The Bypass Contactor serves to shunt power around the SCR stack assemblies to prevent heat build-up in the starter enclosure due to the slight voltage drop across the SCRs. At this point, the **SSM** has the motor operating at full voltage, just as any other starter would.

Other starting methods available in the **SSM** are:

- **Current Ramp:** uses a closed current feedback PID loop to provide a linear torque increase up to a Maximum Current level.
- **Constant Current:** current is immediately increased to the Current Limit point and held there until the motor reaches full speed.
- **Custom Curve:** gives the user the ability to plot torque and time points on a graph. The soft starter will then accelerate the motor following these points.
- **Tachometer Feedback Ramp:** uses a closed loop speed follower method monitoring a tachometer input signal from the motor or load shaft. (PENDING)

Deceleration: the **SSM** provides the user with the option of having the load coast to a stop or controlling the deceleration by slowly reducing the voltage to the motor upon initiating a stop command. The Decel feature is the **opposite of DC injection braking** in that the motor will actually take longer to come to a stop than if allowed to coast to a stop. The most common application for the Decel feature is pumping applications where a controlled stop prevents water hammer and mechanical damage to the system.

1.6 General Protection

Operation of the **SSM** can be divided into 4 modes; Ready, Start, Run and Stop. The CPU provides motor and load protection in all four modes. Additional details on each protection feature can be found in later chapters.

Ready Mode: In this mode, control and line power are applied and the starter is ready for a start command. Protection during this mode includes the monitoring of current for leakage through multiple shorted SCRs or welded contacts on the Bypass Contactor. Other protection features in effect are:

- Starter Temperature
- Shorted SCR
- Blown Fuse Indication
- Phase Reversal (if enabled)
- Line Frequency Trip Window
- External Input Faults

Note: The “Programming Mode” can only be entered from the Ready Mode. During programming, all protection features and start command are disabled.

Start Mode: These additional protection functions are enabled when the soft starter receives a valid Start command:

Chapter 1 - Introduction

- Phase Reversal (if enabled)
- Start Curve
- Acceleration Timer
- Phase Imbalance
- Short Circuit / Load Pre-check (Toe-in-the-Water)
- Ground Fault (Optional)
- External Input Faults
- Accumulated Starting FLA Units (I^2t Protection)
- Overload Protection
- Thermal Capacity

Note: Shorted SCR and Shunt Trip protection are no longer in effect once the soft starter goes into the Start Mode.

Run Mode: The soft starter enters the Run Mode when it reaches full output voltage *and* the motor current drops below the FLA setting (motor nameplate FLA plus service factor) for a pre-determined period of time. During the Run Mode these additional protection features are enabled:

- Running Overload Curve
- Phase Loss
- Under Current / Load Loss
- Over Current / Electronic Shear Pin (Jam Protection)
- External Input Faults

Stop Mode: Once a Stop command has been given, the **SSM** protection features change depending on which Stop Mode is selected.

- Decel Mode: retains all protection features of the Run Mode. At the end of Decel, the motor will be stopped and the protection features change as indicated below.
- Coast-To-Stop Mode: power is immediately removed from the motor and the soft starter returns to the Ready Mode. Additional protection features activated when the stop command is given include:
 - Coast-Down / Back Spin Timer
 - Starts-per-Hour
 - Time Between Starts
 - External Input Faults

1.7 Thermal Overload Protection

The **SSM** plays an important role in the protection of your motor in that it monitors the motor for excessive thermal conditions due to starting, running or even ambient conditions. The **SSM Series** has a Dynamic Thermal Register system in the CPU that provides a mathematical representation of the thermal state of the motor. This thermal state information is kept in memory and is monitored for excesses in both value and rate of change. Input is derived from current imbalances and (optional) RTD measurements making it dynamic to all processes involving the motor. The **SSM** monitors these conditions separately during Start and Run modes to provide proper thermal overload protection at all times.

Start Mode overload protection is selectable using one of three methods:

Chapter 1 - Introduction

- **Basic Protection:** I²t data is accumulated and plotted based on an Overload Curve selected in programming. This is programmed per NEMA Class 5-30 standard curves and is based on the Locked Rotor Current (from the motor nameplate) as programmed into the soft starter.
- **Measured Start Capacity:** the user enters a measured amount of thermal capacity from a pre-selected successful start as a setpoint to the Thermal Register for the soft starter to follow.
- **Learned Curve Protection:** the user sets the soft starter to the “LEARN” mode and starts the motor under normal starting conditions. The CPU then samples and records 100 data points during the start curve, analyzes them and creates a graphical representation in memory. The soft starter is then switched to Curve Follow protection mode and monitors motor performance against this curve. This feature is especially useful in initial commissioning tests to record a base line performance sample (in this case, it is not necessarily used for motor protection).

Run Mode overload protection is initiated when the **SSM** determines that the motor is At-Speed. Overload Protection is initiated when the motor RMS current rises above a “pick-up point” (as determined by the motor nameplate FLA and service factor). Run mode protection is provided by the CPU monitoring the Dynamic Thermal Register. Data for the Dynamic Thermal Register is accumulated from I²t calculations and cooling rates. A trip occurs when the register reaches 100% as determined by the selected Overload Protection Curve (NEMA Class 5-30 standard curves) and is based on the programmed Locked Rotor Current indicated on the motor nameplate. The Dynamic Thermal Register is altered, or “biased”, by the following conditions:

- **Current Imbalance:** will bias the register higher to add protection from additional motor heating during a current imbalance condition.
- **Normal Cooling:** provided when the motor current drops below the pick-up point or the motor is off line. The cooling rate is lower for motors that are off-line (such as after a trip) since cooling fans are also inoperative.
- **RTD Input:** (requires the optional RTD monitor card): will bias the register in either direction based on real-time input of the motor, bearing and even ambient temperature conditions.
- **Dynamic Reset** is another feature that adds reliability and consistency to the performance of the **SSM** soft starter. If a motor overload condition occurs and the soft starter trips, it cannot be reset until sufficient cool down time has elapsed. This cool down time is determined by the thermal state of the motor when it tripped (i.e. hot motors cool more quickly due to additional convection). The cool down time is also biased by RTD measurements when used.
- **Retentive Memory** provides continuous overload protection and real time reset even if power is lost. Upon restoration of power, the **SSM** will read the Real Time Clock and restore the thermal register to what it should be given the elapsed time.
- **Learned Reset Capacity** is a feature that is unique to the **SSM**. By sampling the amount of thermal capacity used in the previous three successful starts, the **SSM** will not allow a reset until a sufficient amount of thermal capacity has been regained in the motor. This prevents nuisance tripping and insures that unsuccessful start attempts (which would otherwise use up the starts-per-hour capacity of the motor) are not counted.

Chapter 1 - Introduction

1.8 Firing Circuit

The SCR gate firing circuit is critical to performance and stability of the system. The **SSM** firing circuit includes several unique features which enhance the ruggedness, noise immunity and flexibility for maximized performance. This performance is attained without the need for reactors or field installed devices used in other systems, regardless of conditions (line impedance, short circuit capacity or switching transients). These features include:

Auto Synchronizing of the gate timing pulses match each phase firing angle to their respective phases. The **SSM** actively tracks minor shifts in the line frequency, avoiding nuisance tripping that may happen with conventional gate firing systems. This is especially useful on portable or backup generator supplies, allowing the **SSM** to be used confidently in applications that have unstable power.

Sustained Pulse firing keeps the firing signal active for 270 electrical degrees, ensuring that the DC gate pulse causes the SCR to fire even if line noise is present at a critical moment. This provides the **SSM** with superior noise immunity and protects against mis-firing, enhancing the system reliability.

Closed Loop Firing Control is a method of balancing the SCR firing pattern based on the desired output. The CPU uses feedback signals from both the output current and voltage providing smooth output and preventing imbalances during ramping which prevents unnecessary motor heating.

Transformer Isolation of the firing signals prevents interference from line noise and EMI/RFI signals that may be present. Specially designed 120V 3 phase isolation transformers provide potential measurement, firing board power and gate power systems while being isolated from the line voltage. High isolation Ring Transformers are used to step this down to 28VAC for the Sustained Pulse firing circuit, providing further isolation for the SCR gates. Additional magnetic isolation is provided via a separate Control Power Transformer, which powers all of the low voltage controls and the CPU.

Fiber Optic Isolation is provided for all signal interfaces between the Medium Voltage and Low Voltage systems. Even the current signals from CTs are converted to fiber optic signals for maximum isolation and safety.

1.9 Electronics

The **SSM** electronics systems are divided into two categories, Low Voltage and Medium Voltage, based solely on where they are located in the starter structure.

Low Voltage electronics include the Keypad Operator Interface, CPU and Main Power PC boards are located in an isolated Low Voltage Compartment of the enclosure.

- **Keypad Operator Interface:** a 2 line x 20 character LCD display with backlighting for low ambient conditions. The display reads out in truncated English and can show multiple data points in each screen. Also included are 12 LED indicators, which include Power, Run, Alarm, Trip and the status of the 8 Aux. Relays. It communicates to the CPU via a serial link and, if necessary, can be remotely mounted up to 1000' from the soft starter.
- **CPU Board:** where the microprocessor and communications co-processor reside. It is attached to the main power board. It communicates the Keypad Operator

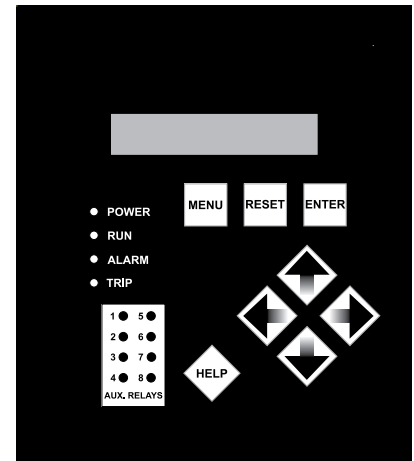

Keypad Operator Interface

Chapter 1 - Introduction

Interface via serial links. The CPU determines operating functions, stores user programming and acts upon feedback signals for faults, metering and historical data. This board also contains the flash EEPROM and SRAM memory, as well as the Analog I/O and terminations.

- **Main Power Board:** is also referred to as the Firing Board. It contains the Digital I/O relays and interfaces to the TCB board (see below) for user interface. It also controls the sequencing of the Isolation and Bypass contactors with the SCR firing. This board generates all firing signals for the SCR stacks and receives feedback signals from fiber optic transmitters. It converts analog levels to digital signals for the CPU. These firing pulses are via fiber optic signals to isolate them from the Medium Voltage environment.

Control Electronics are located in the Medium Voltage section of the soft starter. The main line power must be disconnected before these electronics can be accessed. They include the TCB, Gate Drive and Temp/CT boards.

- **TCB (Terminal and Control Board):** is the user connection interface board. It is located in the Medium Voltage section in order to satisfy UL termination requirements, but does not actually connect directly to the medium voltage components other than the contactor coils. This board contains the user terminal blocks, output relays (duplicated), inputs and control power connections. It also contains additional timed relays for interfacing with Power Factor Correction contactors (if used) and other external devices. Please note Power Factor Capacitor warnings in Section 2.8.
- **Gate Drive Boards:** located directly on the SCR stacks. These boards communicate to the Main Power board via fiber optic cables. They amplify the gate pulse signals with power from the Ring Transformers to create the Sustained Pulse Firing of the SCRs. There is one Gate Drive board for each pair of SCRs in each stack.
- **Temp / CT Boards:** are attached to the Gate Drive boards on the SCR stacks and provide the heat sink temperature and current signals back to the Main Power Board via fiber optic cables.
- **MOV Boards:** are attached to standoffs mounted on the SCR heat sinks and are mounted directly below the Gate Drive boards. The MOV boards are used to protect the gate/cathode section of the SCRs.
- **DV/DT Boards:** are also attached to standoffs mounted on the SCR heat sinks and are mounted below the MOV boards. The DV/DT boards are used to reduce voltage transients across the stack assemblies.

Chapter 2 - Installation

2.1 Receiving and Unpacking

Upon receipt of the unit:

- **SSM** units are typically shipped in the vertical position and should be handled accordingly when received. (Units may be crated and shipped horizontally for export delivery.)
- Carefully unpack the unit and inspect it for any shipping damage. Report any damage immediately and file a claim with the freight carrier within 15 days of receipt.
- Verify that the model number on your unit matches your purchase order. The model # is located on a sticker in the low voltage compartment.

2.2 Initial Unit Inspection

- Make a complete visual check of the unit for damage which may have occurred during shipping and handling. Do not attempt to continue installation or start up the unit if it is damaged.
- Check for loose mechanical assemblies or broken wires which may have occurred during transportation or handling. Loose electrical connections will increase resistance and cause the unit to function improperly.
- Prior to beginning the installation, verify that the motor and **SSM** unit are rated for the proper amperage and voltage.

2.3 Location

The proper location of the unit is an important factor in achieving the unit's specified performance and normal operation lifetime. The unit should always be installed in an area where the following conditions exist:

- Ambient Operating Temperature: 0° C to 50° C (32° F to 122° F)
(Optional space heaters can be provided for operation in ambient temperature to -20° C.)
- Protected from rain and moisture.
- Humidity: 5% to 95% non-condensing.
- Free from metallic particles, conductive dust and corrosive gas.
- Free from excess vibration (below 0.5G)

2.4 Dimensions

Ratings				Standard Type SSM Soft Starter				Optional Soft Start Only*			
Volts	Max. Amps	Nominal Max. HP	KW	Model	NEMA 12			Model	NEMA 12		
					H	W	D		H	W	D
2300	200	800	500	SSM-23200-E-S	92	36	30	SSM-23200-E	92	36	30
	400	1500	1000	SSM-23400-E-S		36		SSM-23400-E			
	600	2500	1900	SSM-23600-E-S		72		SSM-23600-E			
3300	200	1000	600	SSM-33200-E-S	92	36	30	SSM-33200-E	92	36	30
	400	1800	1200	SSM-33400-E-S		36		SSM-33400-E			
	600	3000	2200	SSM-33600-E-S		72		SSM-33600-E			
4160	200	1250	1000	SSM-41200-E-S	92	36	30	SSM-41200-E	92	36	30
	400	2500	2000	SSM-41400-E-S		36		SSM-41400-E			
	600	5000	3750	SSM-41600-E-S		72		SSM-41600-E			
6000/ 7200	200	2500	2000	SSM-60200-E-S	92	72	30	SSM-60200-E	92	36	30
	400	5000	3750	SSM-60400-E-S				SSM-60400-E			
	600	7500	5600	SSM-60600-E-S				SSM-60600-E		72	
11 - 15KV	300	7500	5700	SSM-130300-E-S	92**	120**	44**	See 15kV manual for details			
	600	15000	11000	SSM-130600-E-S	93**	84**	96**				

* **Must be used with customer supplied line start panel.**

** **11 - 15KV only available in NEMA1 configuration.**

Note: Dimensions are for reference only and subject to change. Contact factory for exact dimensions.

Chapter 2 - Installation

2.5 Mounting

Local electrical codes and IEEE Standards should be adhered to when making connections. When mounting on a concrete slab with a wireway, ensure that the cabinet is level for proper door operation. Clear the area of any additional equipment which may interfere with door operation and consult local codes for proper clearances and access.

Reinforcing channels extend across the front and rear of each enclosure base. In each base there is a bolt hole sized for a ½" bolt. For proper fault and seismic bracing, use all four bolt holes. With multiple enclosures, bolt all bases in this manner. Anchor the bolts per local codes. Structures mounted in this manner may be free standing or flush against a wall, since all unit components are accessible from the front.

2.6 Additional Equipment

If conduit entry locations are required in areas other than the removable plates, cover the electrical assemblies to prevent metal filings from becoming lodged in areas which may cause a reduction in the high voltage clearances or a short circuit. After the work is completed, thoroughly clean the area and reinspect the unit for foreign material.

2.7 Before Applying Power

When installing the standard **SSM** NEMA Class E2 Soft Starter, remove the tie wraps holding down the "blown fuse" indicators before supplying power to the unit. Removable conduit entry plates are located on the top and either side of the unit (does not apply to "Soft Start Only" units). After locating the position of the conduit termination site, remove the plates, drill and punch the holes. Replace the plates and terminate the conduit. This prevents metal filings from contaminating the interior of the unit.

2.8 Warnings

- **Do not service this equipment with voltage applied!** The unit can be the source of fatal electric shocks! To avoid shock hazard, disconnect main power and control power before working on the unit. Warning labels must be attached to terminals, enclosure and control panel to meet local codes.
- **Do not connect (PFC) capacitors to the load side (motor side) of the unit.** This will cause di/dt damage to the SCRs when they are turned on.
- **Do not connect the capacitors to the input side of the unit.** If you cannot avoid using capacitors across the power lines, they must be located as far upstream as possible of the input line contactor. In this situation, an optional power factor correction (PFC) capacitor contactor should be specified. For additional information and specifications, please contact the factory.
- **Never interchange the input and output power connections on the unit.**

 DANGER
HAZARDOUS VOLTAGE
Disconnect all power supplying this equipment prior to working on it.
Failure to follow this instruction will result in death or serious injury.

 CAUTION
SCR DAMAGE
Do not connect (PFC) capacitors to the load side of the unit
Doing so will cause DI/DT damage to the SCRs when energized

 WARNING
SAFETY HAZARD
Do not bypass electrical or mechanical interlocks
Failure to follow this instruction will cause severe equipment damage, serious injury or death

Chapter 2 - Installation

This will cause excessive voltage to the control circuit logic.

- **For bus protection, it is strongly recommended to use non-gap lightning arrestors in areas where lightning is a significant problem.** The arrestors should be mounted on the nearest utility pole.

2.9 Medium Voltage Power Connections

Use a properly calibrated torque wrench to tighten all MV connections according to the chart.

2.9.1 Standard SSM NEMA Class E2 Soft Starter

On the standard **SSM** NEMA Class E2 Soft Starter, the connections should be made directly to the main disconnect switch. (Splice Kit also available).

Follow the specs on the splice kit and mounting torque requirements when landing the line and load leads. See section 1.4.

2.9.2 Optional "Soft Start Only" Package

On the optional "Soft Start Only" package, the input power line connections are made at the top of the line connections (SCR module assembly) on the rear panel. See section 7.4 standard wiring diagram - Optional "Soft Start Only".

2.9.3 Load Connections

Motor leads are connected to the bus terminals labeled "T1," T2" and "T3" at the bottom of the power bridge. Utilize 3M 130C 2" (two inch) tape on motor leads. (See label inside unit.)

Bolt Size	Torque at Full Engagement (ft - lbs)
1/4 - 20	6
3/16 - 18	12
3/8 - 16	18
7/16 - 14	30
1/2 - 13	45
9/16 - 12	68
5/8 - 11	90
3/4 - 10	150
7/8 - 9	240
1.0 - 8	245

Torque Specs for MV Power Connections

2.10 Control Connections - TCB (Terminal and Control Board)

Chapter 2 - Installation

For a larger view of this drawing, please see Section 7.4.

2.10.1 SSM-TCB Board

The **SSM-TCB** board provides interconnections between the main power and CPU boards and the customer's control logic connections. It is a 120 VAC control board with several auxiliary dry control contacts, built-in time delay circuits and emergency bypass functions. It also controls the sequence of the inline isolation and bypass contactor and provides provisions for shutdown interlocks. (see section 2.10.2)

2.10.2 Description of Terminal Connections

Start/Stop Control - Terminal Block 1 (TB1) :

- Positions 1 and 9 are the 120 VAC control *Start/*

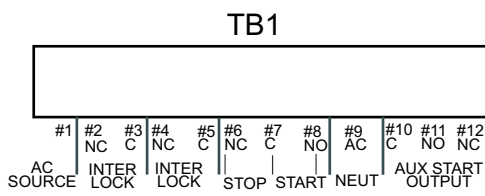

Stop Control
Figure 2 - 1

power. The recommended VA is 750VA or higher (if the control power transformer (CPT) has not been supplied). The CPT is supplied on all complete starter units (i.e., NEMA Class E2 starters).

Note: This transformer should not be used for other 120VAC operations or power sources.

- Positions 2-3 and 4-5 have factory jumpers installed and can be removed for customer's normally closed, dry, shutdown contacts (See Fig 2-1 above).
- Positions 6-7-8 are for either two wire or three-wire start/stop logic. Two wire is connected to positions 6 and 8 with a N.O. dry, maintained start/stop contact. Three wire control connects to 6 with 7 as the stop push-button, and the start push-button is connected to 7 and 8.
- Positions 10-11-12 are a dry Form C contact. The contact is an immediate start/stop contact.

Emergency Bypass Control - Terminal Block 2 (TB2):

- Positions 1 and 2 are for an emergency bypass contact. If a dry contact closes position 1 and 2, this causes the CPU to be shut off so there is no display. Then when a start is initiated, it pulls in the inline isolation contactor which starts the motor across the line.
- Positions 3-4-5 are a Form C contact. This is a dry

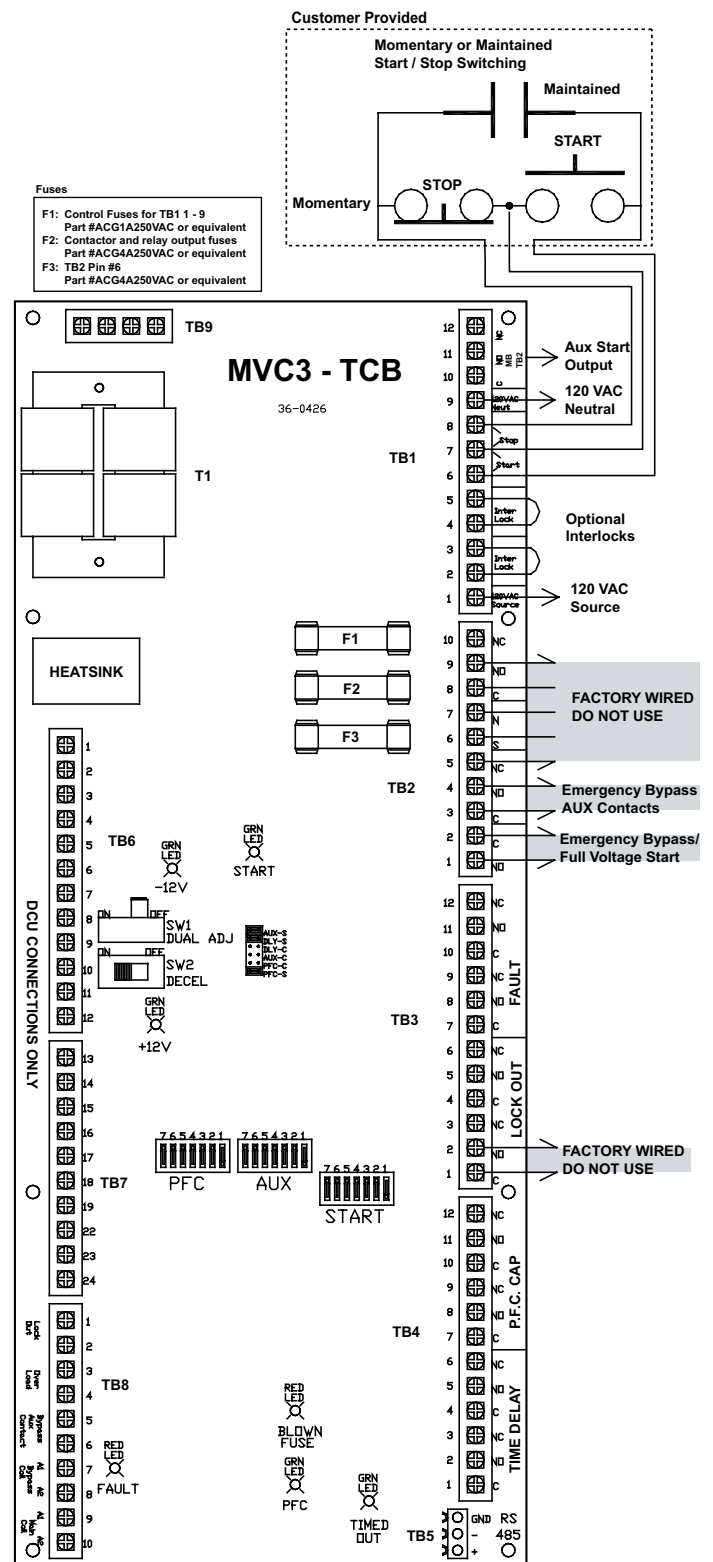

TCB (Terminal and Control Board)
Figure 2 - 2

Chapter 2 - Installation

contact that is initiated by the emergency contact being closed. It provides indication of the emergency bypass mode.

- Positions 6 and 7 is a customer connection for control power. Position 6 is the 120 VAC supply at (400 VA) and position 7 is the return.
- Positions 8-9-10 are a Form C contact. The dry contact is a delayed start/stop contact. The amount of delay is determined by X1, X2 and SW3 (see "Switch Positions" and "Jumper Selection" on the next page). Note: Additional Time Delay to SP2 of the CPU programming.

Fault - Terminal Block 3 (TB3):

- Positions 1-2-3 and 4-5-6 are sets of Form C contacts. These are a dry contact that operates when a blown fuse indication is given or disconnect is open.
- Positions 7-8-9 and 10-11-12 are sets of Form C contacts. These are fault contacts that change state if any fault condition occurs.

Optional Relay - Terminal 4 (TB4):

- Positions 1-2-3 and 4-5-6 are sets of Form C contacts. These are auxiliary time delay contacts that will change state (after a delay) when the Start contact is initiated. X3, X4 and SW4 determine the amount of delay. (See switch position and Jumper selection on the following page)
- 7-8-9 and 10-11-12 are sets of Form C contacts. These are power factor correction capacitor (PFC) contacts to pull in an isolation contactor for the power factor correction capacitors (if required by the application). These will change state when the At Speed contact is initiated. X5, X6 and SW5 determine the amount of delay. (See "Switch Positions" and "Jumper Selection" on the following page). Note: This delay is in addition to SP2 of the CPU programming.

Terminal 5 Block (TB5):

RS-485 connections: software required (if wiring distance is >25 ft then make use of termination resistors as needed). Minimum 22 gauge twisted pair wiring.

Terminal Block 6 (TB6):

(Factory wired) Main power board connections 1-12

Terminal Block 7 (TB7):

(Factory wired) Main power board connections 13-24

Terminal Block 8 (TB8):

(Factory wired if complete NEMA E2 controller is supplied. If soft start only is supplied it is customer wired.)

- Positions 1 and 2 accept dry, normally closed contacts from blown fuse indicators and/or disconnect interlock contact.
- Positions 3 and 4 accept dry, normally closed contacts from an external overload protection device (required if emergency bypass is used).
- Positions 5 and 6 accept dry, normally closed contact from the bypass contactor for an At Speed indication. (Factory wired)
- Positions 7 and 8 are wired to the coil of the bypass contactor and energizes and de-energizes the contactor. (Factory wired)
- Positions 9 and 10 are wired to the coil of the inline isolation contactor and energizes and de-energizes the contactor.

Note: All customer contacts are 960VA, 120VAC (Max) rated dry contacts.

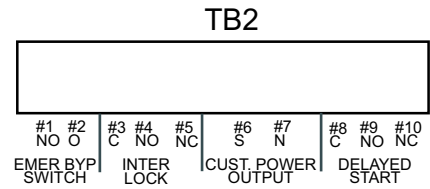

*Emergency Bypass Control
Figure 2 - 3*

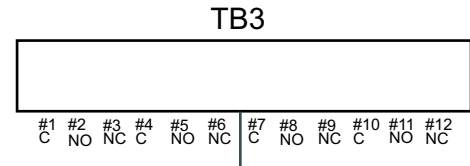

*Lockout/Fault Contacts
Figure 2 - 4*

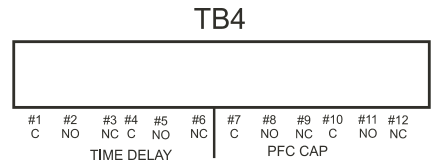

*Time Delay/PFC Cap
Figure 2 - 5*

Chapter 2 - Installation

LEDs provided on the TCB board (for low voltage testing only):

- -12 VDC power supply
- +12 VDC power supply
- Start = start is initiated to TCB board
- Fault = any fault has occurred
- Fuse Blown = disconnect open or blown fuse has activated
- PFC On = Power Factor Correction Capacitor contacts have energized
- Timed Out = Auxiliary time delay contacts have energized

Jumper Selection

Start Delay (Refer to Figure 2 - 6)

This is a selectable delay period between the initiation of the start command and when the CPU actually receives the start signal. Selecting Jumper X1 or X2 determines the method by which this delay (in cycles or seconds) is calculated. See SW3 below for instructions on setting the actual delay time.

- X1 = (DLY-C) Start time delay in cycles
- X2 = (DLY-S) Start time delay in seconds (Factory setting)

Auxiliary (Start) Delay (from the time the start is initiated to when contacts change state). Selecting jumper X3 or X4 determines the method by which this delay is calculated (cycles or seconds). See SW4 below for instructions on setting delay time.

- X3 = (AUX-C) Auxiliary time delay in cycles
- X4 = (AUX-S) Auxiliary time delay in seconds (Factory setting)

Power Factor Correction (PFC) Capacitor Contactor Delay (From the time the bypass closes to when contacts change state). Jumper selection determines the method by which this delay is calculated. See SW5 for instructions.

- X5 = (PFC-C) Time delay in cycles
- X6 = (PFC-S) Time delay in seconds (Factory setting)

Switch Positions (Refer to Figure 2 - 7)

- SW1 = ON = Dual Adjustment
OFF = Disabled
- SW2* = Not used.
- SW3 = Start Delay; 7 position dip switch that use binary code to count up to 127 seconds/cycles (see "Jumper Selection" above).
- SW4** = Auxiliary (Start) Delay 7 position dip switch uses binary count up to 127 seconds/cycles. (See jumper selection above.) Factory setting: 1 second
- SW5** = PFC time delay; 7 position dip switch uses binary count up to 127 seconds/cycles. (See jumper selection above) Factory setting: 1 second.

*Note: This switch interacts with the CPU programming when the Decel function is enabled. Leave this switch in the OFF position.

**Note: These times are in addition to SP2 in the CPU setpoints.

2.11 Grounding

- Connect the grounding cable to the terminal labeled "GND" at the bottom of the main panel.
- In the three phase 120 VAC from the potential transformers, Phase B is internally grounded to the cabinet for phase sequencing.
- Check all the ground connections with an ohmmeter between each panel and

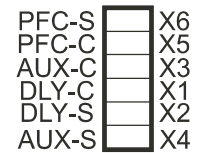

Jumper Selections
Figure 2- 6

Switch Positions



Example:

Switch settings are cumulative. Setting dip switch positions 1, 2, and 3 to "on" = 1+2+4 = 7 seconds total time. Note: Applies to SW3, SW4 & SW5.

Switch Positions
Figure 2- 7

Chapter 2 - Installation

- earth ground.
- On the standard **SSM** NEMA Class E2 starter, the ground bus is located at the bottom of the box. The Optional "Soft Start Only" has the ground bus at the bottom of the main panel.

⚡
DANGER

HAZARDOUS VOLTAGE

Disconnect all power supplying this equipment prior to working on it.

Failure to follow this instruction will result in death or serious injury.

**2.12 Reference Section - THIS SECTION IS FOR REFERENCE ONLY.
FIELD WIRING/CONNECTIONS ARE NOT REQUIRED.**

2.12a Optional RTD Board

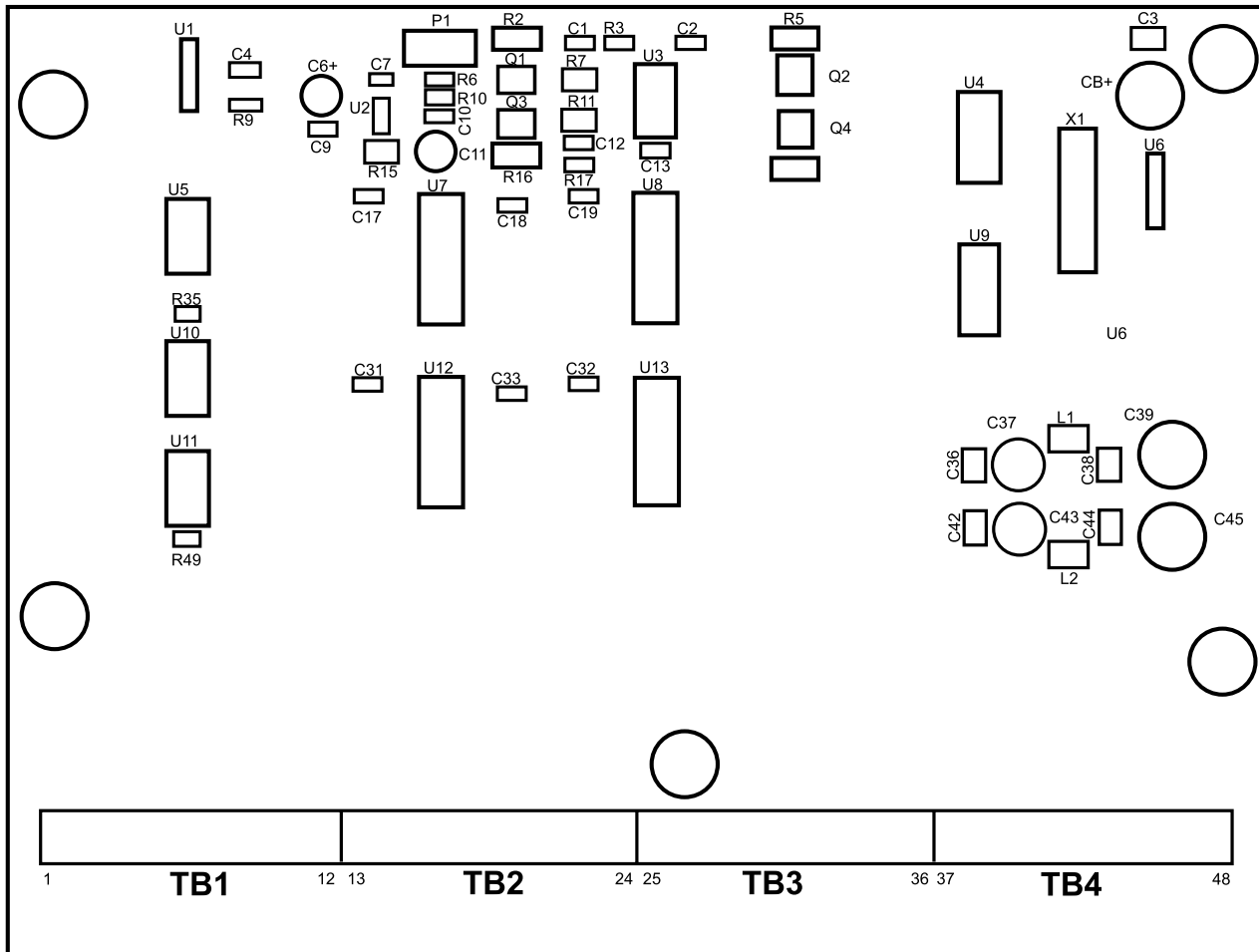

Chapter 2 - Installation

2.12b Communications Board

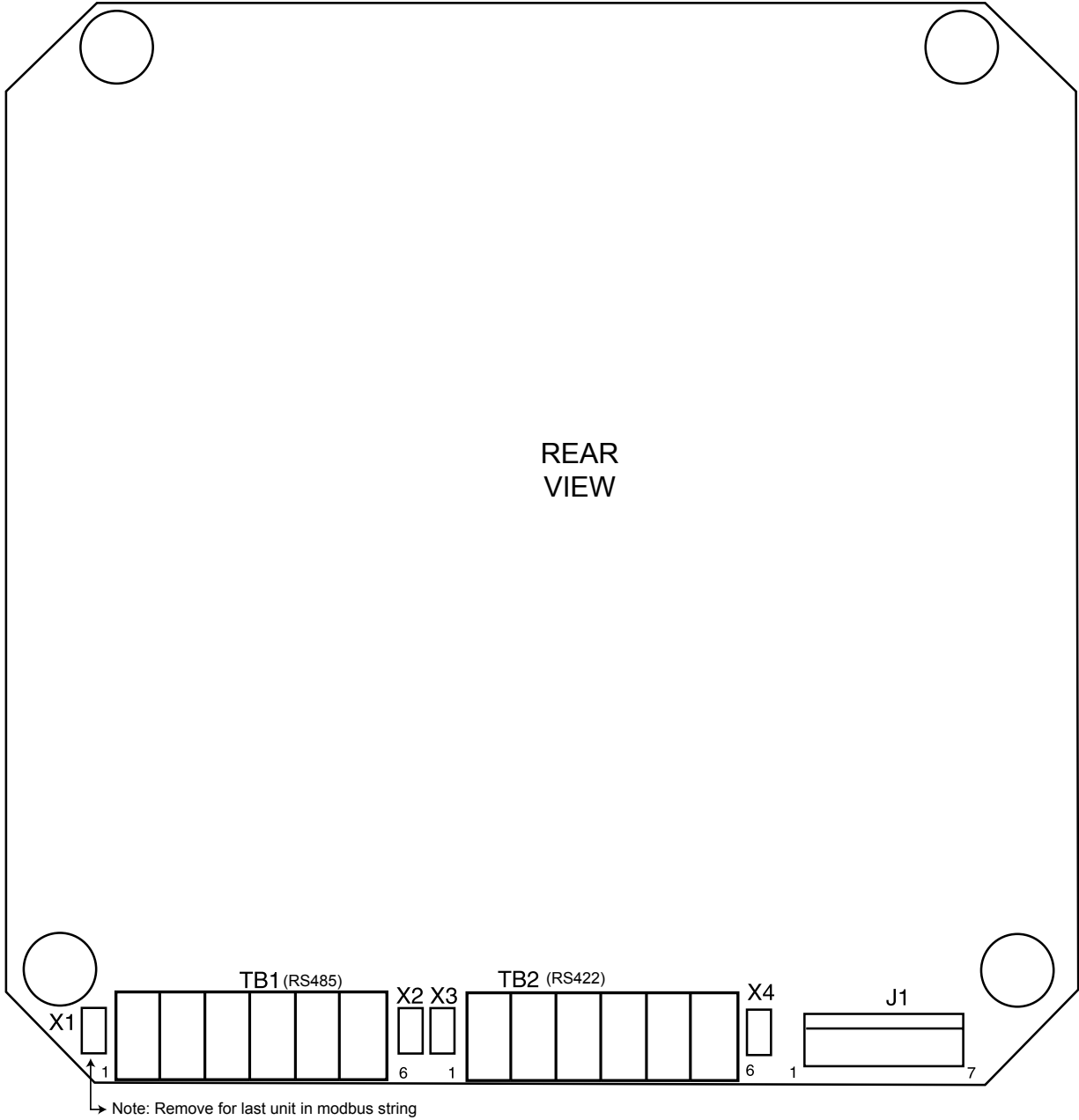

2.12c Communications Board Connections

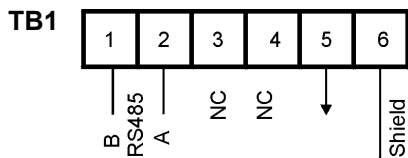

RS485 Connections
(Customer Connections)

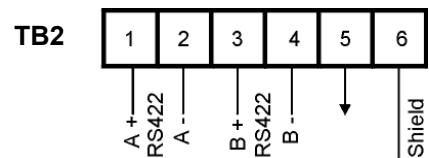

RECEIVE TRANSMIT
RS422 Connections
(Factory Only)

Chapter 2 - Installation

2.12d Power Board

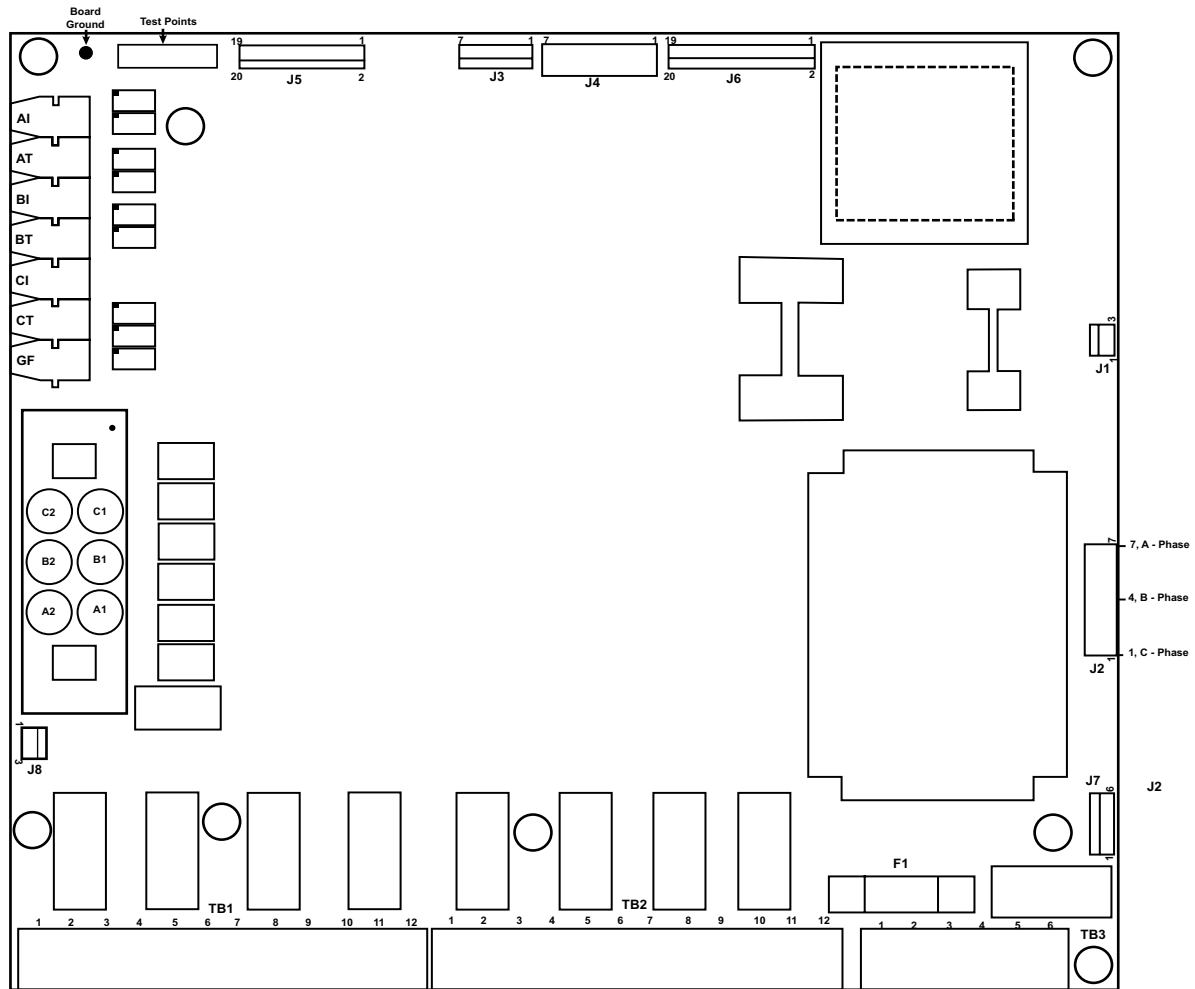

2.12e Power Board Connections

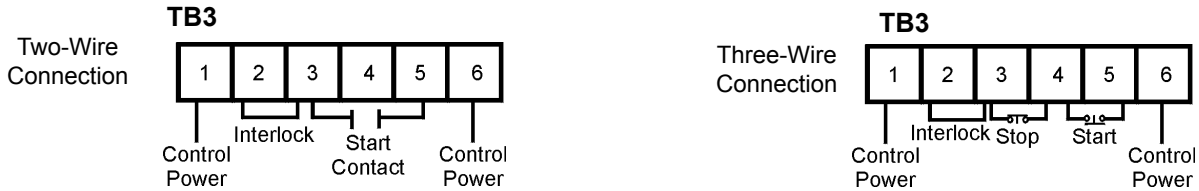

TB1												TB2											
Factory use only. Do not reprogram.												Refer to Setpoint Page 5 for programming information											
1	2	3	4	5	6	7	8	9	10	11	12	13	14	15	16	17	18	19	20	21	22	23	24
C	N.O.	N.C.	C	N.O.	N.C.	C	N.O.	N.C.	C	N.O.	N.C.	C	N.O.	N.C.	C	N.O.	N.C.	C	N.O.	N.C.	C	N.O.	N.C.
AUX1 (TRIP) Relay			AUX2 (ALARM) Relay			AUX3 (RUN) Relay			AUX4 (AT SPEED) Relay			AUX5 Relay			AUX6 Relay			AUX7 Relay			AUX8 Relay		

(Max Relay Contact Rating is 240 VAC, 4A, 960VA)

Chapter 2 - Installation

2.12f CPU Board Connections

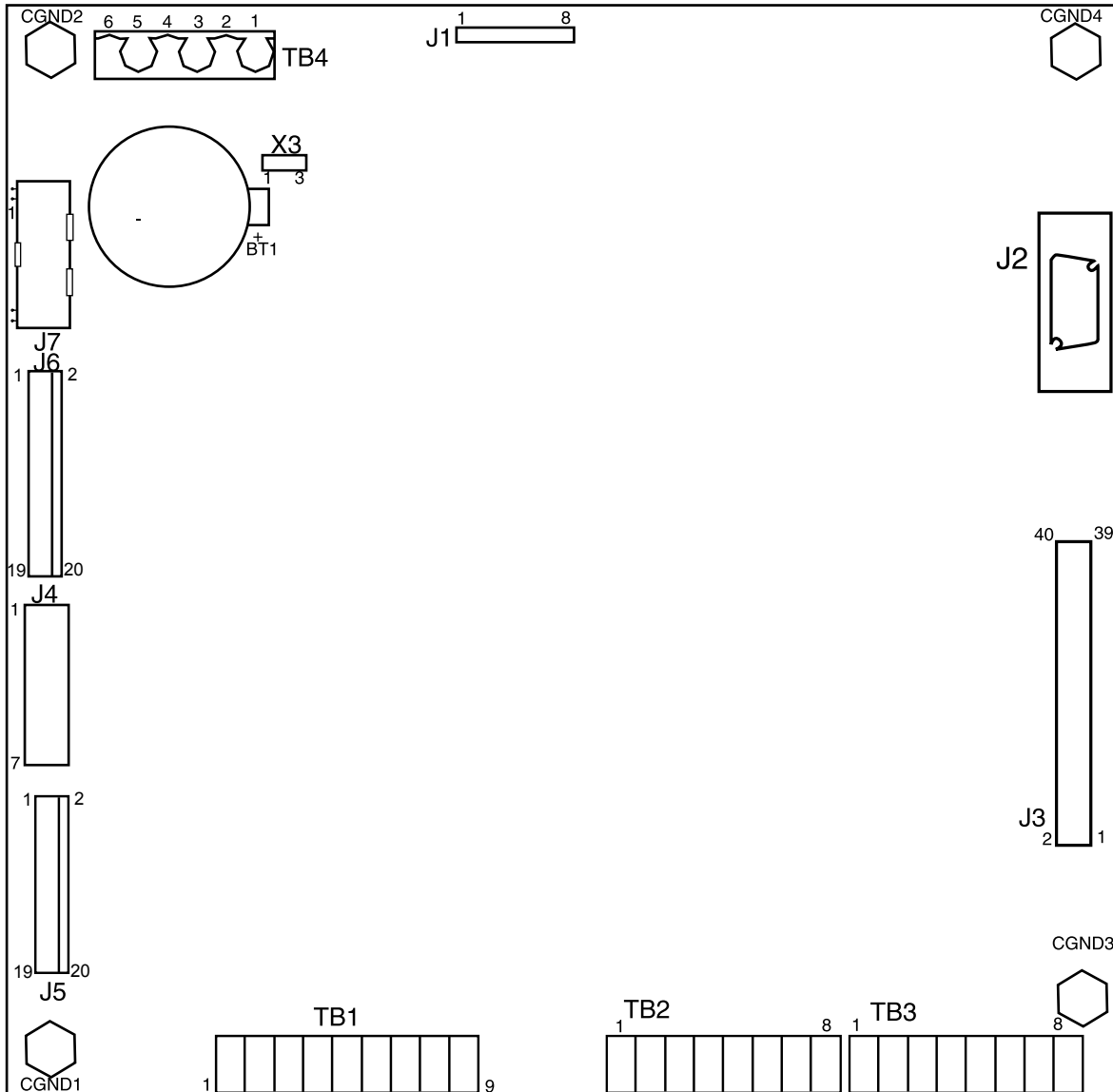

Contact factory for remote reset connections

Factory wired. Do not change

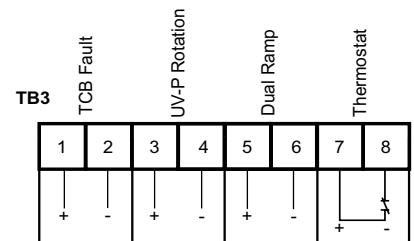
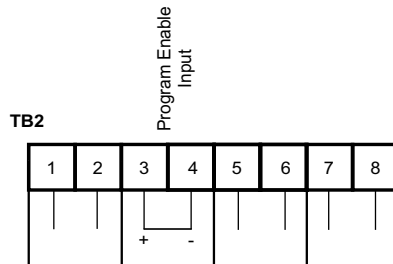
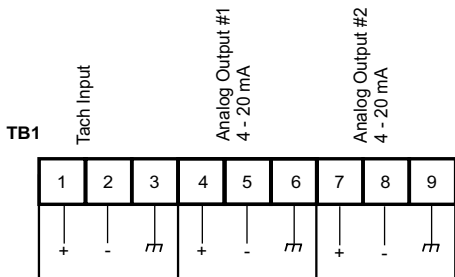

Note: Install program jumper to enable setpoint programming. Jumper must be removed after programming or for prolonged storage to preserve settings.

Chapter 3 - Start-Up

3.1 Preliminary Start-Up Check List

Please make the following checks before applying power to the unit:

- Qualified personnel have hi-potted the line and load wiring before connecting to the soft start. (Typically 1.5 x Rated Voltage)
- Verify that all wiring is completed and all connections are tightened.
- Check the motor nameplate and confirm the unit is programmed with the correct motor FLA.

Note: It is necessary to connect the line power to L1, L2 and L3, or the “Phase Rotation Protection” will be activated.

- Verify control logic via 120V test switcher (available on standard SSM NEMA Class E2 Starters only). A separate 120 VAC test receptacle can be supplied to the control logic without powering up the medium voltage section for control logic testing. It also allows isolation of the 120 VAC from back-feeding the control power transformer.
- Connect control supply (Optional “Soft Start Only” Package only). The “On” and “Stop” LEDs will light up.
- Review all parameters and readjust as required. See *Chapter 5 - Programming* for detailed instructions. (Try factory settings first)
- Verify that the interlocks for the system are installed and working properly.
- Verify that the feed transformer is correctly sized for the motor(s).
- Check for any loose mechanical parts or metal debris in the enclosure.
- Check the motor strapping and connections.
- Verify that the unit is properly grounded.
- Remove tie wraps from Blown Fuse Indicator.
- Connect line voltage to line terminals.



3.2 Introduction

It is best to operate the motor at its full load starting condition to achieve the proper time, torque and ramp settings. Initial settings are set to accommodate most motor conditions. **TRY INITIAL SETTINGS FIRST.** See Section 5.1.2 Starter Configuration (Setpoint Page 2) to make any adjustments.

3.3 Acceleration Adjustments

The unit is set at the factory with typical starting characteristics that perform well in most applications. When the system is ready to start, try the initial unit settings. If the motor does not come up to speed, increase the current limit setting. If the motor does not start to turn as soon as desired, raise the starting voltage adjustment. Adjustment description and procedures are described as follows. See Section 5.1.2 Starter Configuration (Setpoint Page 2) for additional Accel settings.

3.3.1 Starting Voltage

Factory Setting = 20% of line voltage

Range = 0% - 100% of line voltage

Starting voltage adjustment changes the initial starting voltage level to the motor.

3.3.2 Ramp Time

Factory Setting = 10 sec.

Range = 0 - 120 sec.

Ramp time adjustment changes the amount of time it takes to reach the current limit point or full voltage if the current limit point was not reached.

Note: Refer to your motor manual for the maximum number of starts per hour allowed by the manufacturer and do not exceed the recommended number.

Chapter 3 - Start-Up

Factory Setting = 350% of motor FLA
Range = 200% - 600% of motor FLA

The current limit adjustment is factory set for 350% of the motor FLA. The range of adjustment is 200% to 600%. The main function of current limit is to cap the peak current. It may also be used to extend the ramping time if required. The interaction between the voltage ramp and the current limit will allow the soft start to ramp the motor until the maximum current is reached and the current limit will hold the current at that level. The current limit must be set high enough to allow the motor to reach full speed. The factory setting of 350% is a good starting point. **Do not set the current limit too low on variable starting loads. This could cause the motor to stall and eventually cause the overload protection to trip.**

Note: If the motor does stall, refer to the motor manufacturer's motor data for the proper cooling time.

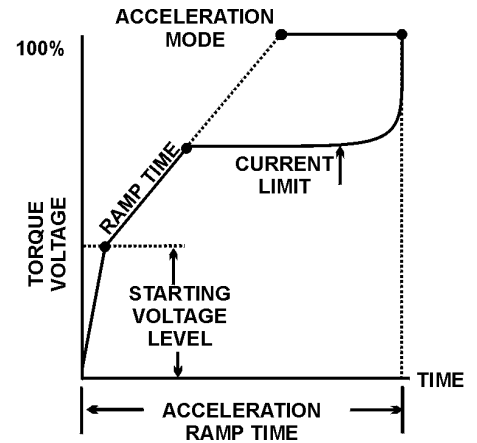

3.4 Deceleration Adjustments (Pump Control)

Decel extends the stopping time on loads that would otherwise stop too quickly if allowed to coast to stop. Decel control provides smooth deceleration until the load comes to a stop. Three adjustments optimize the deceleration curve to meet the most demanding requirements. **The unit is shipped from the factory with the decel feature disabled.**

Deceleration Applications

The unit is shipped from the factory with the decel feature disabled.

Apply power and adjust the soft start before enabling or modifying the deceleration adjustments. Both acceleration and deceleration adjustments should be made under normal load conditions.

The deceleration feature provides a slow decrease in the output voltage, accomplishing a gentle decrease in motor torque during the stopping mode. This is the **OPPOSITE OF BRAKING** in that it will take **longer** to come to a stop than if the starter were just turned off. The primary use of this function is to reduce the sudden changes in pressure that are associated with "Water Hammer" and slamming of check valves with centrifugal pumps. Decel control in pump applications is often referred to as **Pump Control**.

In a pump system, liquid is being pushed uphill. The force exerted by gravity on the column of liquid as it goes up hill is called the "Head Pressure" in the system. The pump is sized to provide enough Output Pressure to overcome the Head Pressure and move the fluid up the pipe. When the pump is turned off, the Output Pressure rapidly drops to zero and the Head Pressure takes over to send the fluid back down the hill. A "Check Valve" is used somewhere in the system to prevent this (if necessary) by only allowing the liquid to flow in one direction. The kinetic energy in that moving fluid is suddenly trapped when the valve slams closed. Since fluids can't compress, that energy is transformed into a "Shock Wave" that travels through the piping system looking for an outlet in which it dissipates. The sound of that shock wave is referred to as "Water Hammer". The energy in that shock wave can be extremely damaging to pipes, fittings, flanges, seals and mounting systems. By using the Soft Stop/Deceleration feature of the **SSM**, the pump output

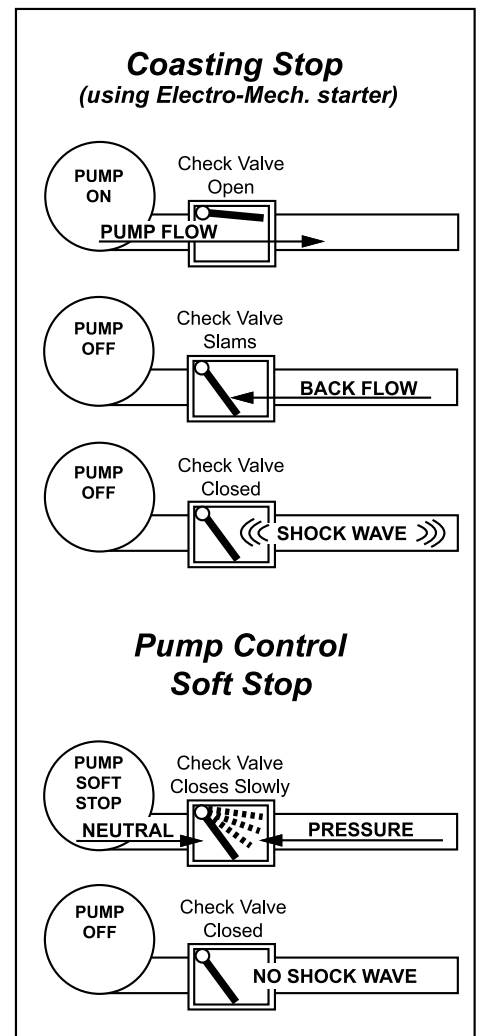

Chapter 3 - Start-Up

torque is gradually and gently reduced, which slowly reduces the pressure in the pipe. When the Output Pressure is just slightly lower than the Head Pressure, the flow slowly reverses and closes the Check Valve. By this time there is very little energy left in the moving fluid and the Shock Wave is avoided. When the output voltage to the motor is low enough to no longer be needed, the **SSM** will end the Decel cycle and turn itself off.

Another common application for decel control is on material handling conveyors as a

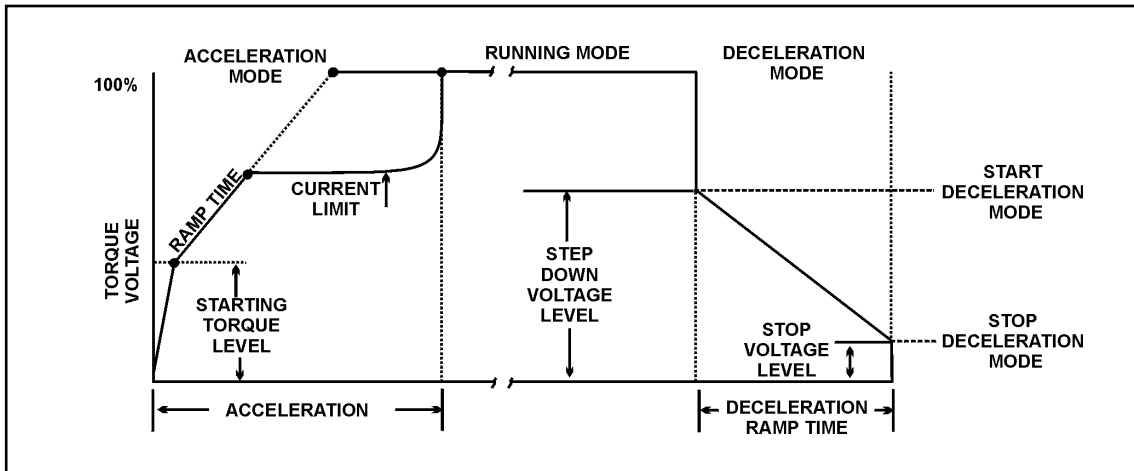

means to prevent sudden stops that may cause products to fall over or to bump into one another. In overhead crane applications, soft stopping of the Bridge or Trolley can prevent loads from beginning to over swing on sudden stops.

3.4.1 Start Deceleration Voltage

Factory Setting = 60% of line voltage

Range = 0% - 100% of line voltage

The step down voltage adjustment eliminates the dead band in the deceleration mode that is experienced while the voltage drops to a level where the motor deceleration is responsive to decreased voltage. This feature allows for an instantaneous drop in voltage when deceleration is initiated.

3.4.2 Stop Deceleration Voltage

Factory Setting = 20% of line voltage

Range = 0% - 100% of line voltage

The stop voltage level setpoint is where the deceleration voltage drops to zero.

3.4.3 Deceleration Time

Factory Setting = 5 sec.

Range = 0 - 60 sec.

The deceleration ramp time adjusts the time it takes to reach the stop voltage level set point. The unit should be restarted and stopped to verify that the desired deceleration time has been achieved.

Note: Do not exceed the motor manufacturer's recommended number of starts per hour. When calculating the number of starts per hour, a decel curve should be counted as a start curve. For example, recommended number of starts per hour = 6, allowable starts with decel cycle per hour = 3.

3.5 Sequence of Normal Operation

- Apply control power and check that the "Power" LED comes on.

Chapter 3 - Start-Up

(Display 1)

- Apply three phase power to the unit. The motor should run only when the start command is applied.
- Apply the start command. (Display 2). The RUN LED will be lit. (Display 3). The AUX3 LEDs will be lit. If the motor does not enter run mode in the set time (Acceleration time limit, see SP8.2), a trip will occur.
- When the motor reaches full speed, the “AUX4” LED (At Speed) will be lit.
- The POWER, RUN, AUX3 LEDs will be lit, indicating that the contact has energized. IA, IB, IC will display the current setting for Phase A, Phase B, and Phase C and the G/F indicates ground fault. (Display 4)
- If the motor decelerates, or stops, during the acceleration period, hit the stop button immediately and open the disconnect line. If the unit does not follow this operational sequence, please refer to the Troubleshooting Chapter.

Display 1 MOTOR STOPPED
READY TO START

Display 2 MOTOR STARTING
00 X FLA

Display 3 OVERLOAD ALARM
TIME TO TRIP: XXX SECS.

Display 4 IA: ___ IB: ___
IC: ___ G/F: ___

It is best to operate the motor at its full load starting condition to achieve the proper time, torque and ramp settings. Initial settings are set to accommodate most motor conditions. **TRY INITIAL SETTINGS FIRST.** See Setpoint Page 2 (page 40) to make any adjustments.

- Initial Voltage
- Soft Start Curve
- Current Limit
- Acceleration Time

If decel is enabled, the following parameters for Deceleration Time, Start Decel Voltage (see Setpoint Page 2 on page 40) and Stop Decel Voltage must also be programmed.

3.6 Emergency Bypass Operation

- Remove input power (using line start section and lock out disconnect).
- Close the emergency bypass contact.
- Re-close disconnect on line start panel.
- Bi-metallic overload protection is required (customer supplied if factory emergency overload protection option has not been included.)

Note: In the emergency bypass mode, there is no overload protection unless a separate (optional or customer supplier) thermal overload relay is installed.

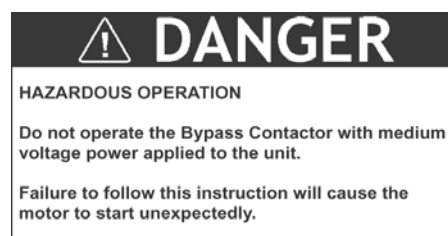

The line start panel is operable as a normal across-the-line starter. When power is applied, the bypass contactor is energized, tying the input terminals directly to its output terminals. When the “ON/OFF” contact is closed, the main contactor is energized and the motor line starts. When the “ON/OFF” contact is opened, the motor is disconnected from the line via the main in-line vacuum contactor.

Chapter 4 - User Interface and Menu Navigation

This chapter explains the keypad operator interface, the LCD descriptions and the programming features

4.1 Keypad/Operator Interface

The **SSM** user keypad/ keypad operator interface consists of:

- 2 row by 20 characters Liquid Crystal Display (LCD)
- 12 LEDs
- 8 pushbuttons

Note: The **SSM** is menu driven and there are three levels of programming. The programming for two of these levels is password protected. Level two requires a three digit password and level three requires a four digit password.

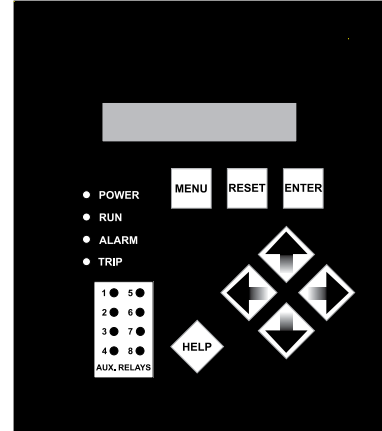

Keypad Operator Interface

Button	MENU	Toggle between the menu selection for metering and setpoint pages.
	RESET	Will clear the trip indicator and release the trip relay.
	ENTER	In the edit mode, press the ENTER pushbutton so the unit will accept the new programming information. When not in the edit mode, the ENTER pushbutton will toggle through the event indicator list (such as alarms or trips)
	HELP	Provides general help information about a specific setpoint or action.
	UP ARROW	Will scroll up through the setpoint and metering menu page. It will scroll to the top of the setpoint page or a section. In edit mode it will increase a setpoint in an incremental step or toggle through the available options in the setpoint.
	RIGHT ARROW	In the main menu the RIGHT ARROW button provides access to the setpoint page. For setpoint pages with multiple columns, the RIGHT ARROW will scroll the setpoint page to the right. When in edit mode it will shift one character to the right.
	DOWN ARROW	Will scroll down through the setpoint pages and down through the setpoints. In edit mode, it will decrement through values and toggle available options in the setpoint.
	LEFT ARROW	Will move to the left through setpoint pages with multiple columns. When in edit mode it will become the backspace key and will shift one character to the left.
LED	Power	Indicates control power is present
	Run	Indicates unit/motor is running
	Alarm	Lights in conjunction with AUX 2 to indicate event or warn of possible critical condition.
	Trip	Lights in conjunction with AUX 1 to indicate a critical condition has occurred.
	AUX 1-8	Auxiliary relays

Note: The directional arrow buttons require careful operation. In edit mode, if the buttons are held for a long period, the scrolling speed will increase.

Chapter 4 - User Interface and Menu Navigation

4.2 Menu Navigation

Notes:

1. The MENU keys allow you to toggle the screens between the Setpoint Menu and the Metering Menu. Simply use the arrow keys to get to the different screens within each menu.
Example: To access Setpoint Page 3: PHASE & GROUND SETTINGS, press the MENU key once and the DOWN ARROW two times.
2. Levels 1, 2 and 3 indicate password protection levels for these setpoint pages.

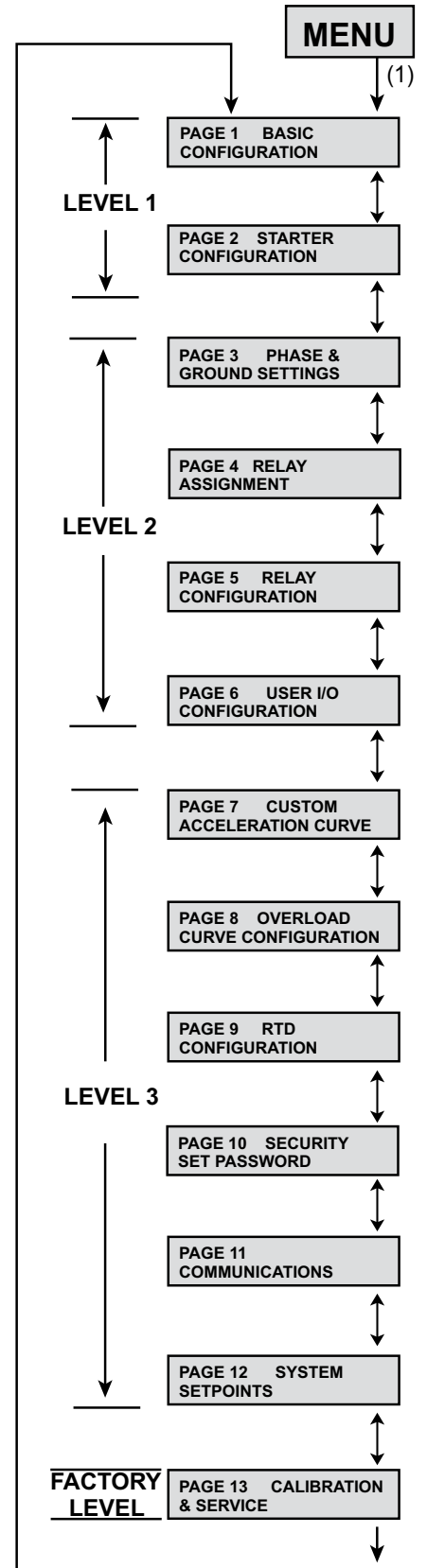

Chapter 4 - User Interface and Menu Navigation

4.2.1 Password Access

Screens in Level 1 of the setpoint menu can be changed without password access because they list basic motor information. Screens in Levels 2 and 3 require passwords because they provide more in-depth protection and control of the **SSM** unit. The password in Levels 2 and 3 can be changed by the user.

NOTE: Setpoints can only be changed when the motor is in Stop/Ready Mode! The SSM will not allow a start if it is still in the Edit Mode. When the unit is in the Edit Mode, an asterisk is displayed in the top right corner screen.

4.2.2 Changing Setpoints

Example 1: Changing Motor FLA

- Press MENU button to display Setpoint Page 1, Basic Configuration
- Press the RIGHT ARROW you will view the screen Motor Full Load Amps.
- Press the ENTER button for edit mode. Note the asterisk (*) in the top right corner of the LCD screen that indicates Edit Mode.
- To change the value, select the UP ARROW or DOWN ARROW.
- To accept the new value, press the ENTER button. The unit will accept the changes and will leave the edit mode. Note the * is no longer in the top right corner of the LCD Display.

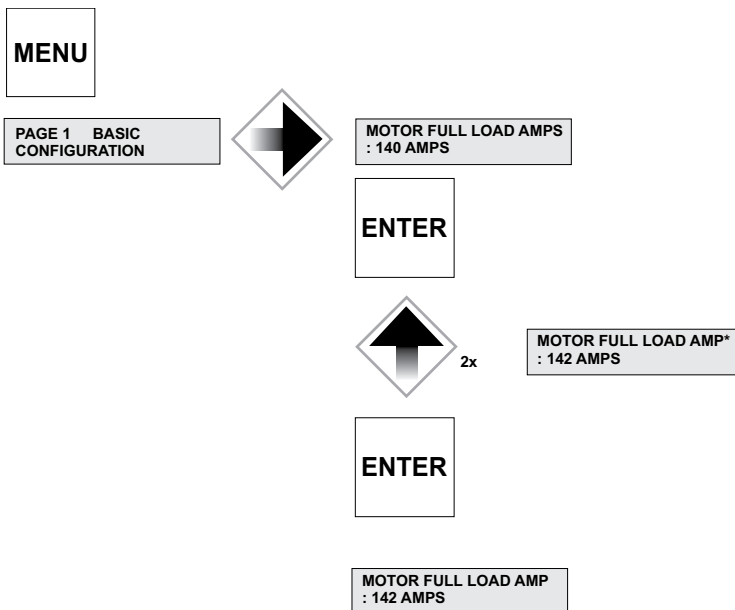

Chapter 5 - Setpoint Programming

The **SSM** has thirteen programmable setpoint pages. In Section 5.1, the setpoint pages are outlined in chart form. In Section 5.2 the setpoint pages are illustrated and defined for easy navigation and programming. Note: Setpoints can only be changed when the starter is in the Ready Mode. Also the soft start will not start when it is in programming mode.

5.1 Setpoints Page List

These charts list the Setpoint Page, the programmable functions and the section.

5.1.1 Basic Configuration (Setpoint Page1)

Setpoint Page	Security Level	Description	Factory Setting Default	Range	Section
Page 1 Basic Configuration	Level 1 No Password Required	Motor Full Load Amps (FLA)	Model dependent	50 - 100% of Unit Max Current Rating (Model and Service Factor dependent)	SP1.1
		Service Factor	1.15	1.00 – 1.3	SP1.2
		Overload Class	10	O/L Class 5-30	SP1.3
		NEMA Design	B	A-F	SP1.4
		Insulation Class	B	A, B, C, E, F, H, K, N, S	SP1.5
		Line Voltage	4160	100 to 7200V	SP1.6
		Line Frequency	60	50 or 60 HZ	SP1.7

5.1.2 Starter Configuration (Setpoint Page 2)

Setpoint Page	Security Level	Description	Factory Setting Default	Range	Section
Page 2 Starter Configuration	Level 1 No Password Required	Start Control Mode	Start Ramp 1	Jog, Start Ramp 1, Start Ramp 2, Custom Accel Curve, Start Disabled, Dual Ramp	SP2.1
		Jog Voltage	Off	5-75%, Off	SP2.2
		Start Ramp #1 Type	Voltage	Current, Voltage, Off	SP2.3
		Initial Voltage #1	20%	0-100%	
		Ramp Time #1	10 sec	0-120 sec	
		Current Limit #1	350% FLA	200-600 %	
		Initial Current #1	200% FLA	0-300%	
		Ramp Time #1	10 sec	0-120 sec	
		Maximum Current #1	350% FLA	200-600 %	
		Start Ramp #2 Type	Off	Current, Voltage, Off	SP2.4
		Initial Voltage #2	60%	0-100 %	
		Ramp Time #2	10 sec	0-120 sec	
		Current Limit #2	350 % FLA	200-600 %	
		Initial Current #2	200% FLA	0-600 %	
		Ramp Time #2	10 sec	0-120 sec	
		Maximum Current #2	350% FLA	200-600 %	
		Kick Start Type	Off	Voltage or Off	SP2.5
		Kick Start Voltage	65%	10-100 %	
		Kick Start Time	0.50 sec	0.10-2.00	
		Deceleration	Disabled	Enabled or Disabled	SP2.6
Start Deceleration Voltage	60%	0-100 %			
Stop Deceleration Voltage	30%	0-59 %			
Deceleration Time	5 sec	1-60 sec			
Timed Output Time	Off	1-1000 sec, Off	SP2.7		
Run Delay Time	1 Sec	1-30 sec, Off	SP2.8		
At Speed Delay Time	1 Sec	1-30 sec, Off	SP2.9		

Chapter 5 - Setpoint Programming

5.1.3 Phase and Ground Settings (Setpoint Page 3)

Setpoint Page	Security Level	Description	Factory Setting Default	Range	Section
Page 3 Phase and Ground Settings	Level 2 Password Protection	Imbalance Alarm Level	15% FLA	5-30 %, Off	SP3.1
		Imbalance Alarm Delay	1.5 sec	1.0-20.0 sec	
		Imbalance Trip Level	20%	5-30 %, Off	SP3.2
		Imbalance Trip Delay	2.0 sec	1.0-20.0 sec	
		Undercurrent Alarm Level	Off	10-90 %, Off	SP3.3
		Undercurrent Alarm Delay	2.0 sec	1.0-60.0 sec	
		Overcurrent Alarm Level	Off	100-300 %, Off	SP3.4
		Overcurrent Alarm Delay	2.0 sec	1.0-20.0 sec	
		Overcurrent Trip Level	Off	100-300 %, Off	SP3.5
		Overcurrent Trip Delay	2.0 sec	1.0-20.0 sec	
		Phase Loss Trip	Disabled	Enabled or Disabled	SP3.6
		Phase Loss Trip Delay	0.1 sec	0-20.0 sec	
		Phase Rotation Detection	Enabled	Enabled Only	SP3.7
		Phase Rotation	ABC	ABC	
		*Ground Fault Alarm Level	Off	5-90 %, Off	SP3.8
		*Ground Fault Alarm Delay	0.1 sec	0.1-20.0 sec	
		*Ground Fault Loset Trip Level	Off	5-90 %, Off	SP3.9
		*Ground Fault Loset Trip Delay	0.5 sec	0.1-20 sec	
		*Ground Fault Hiset Trip Level	Off	5-90 %, Off	SP3.10
		*Ground Fault Hiset Trip Delay	0.008 sec	0.008-0.250 sec	
		Overvoltage Alarm Level	Off	5 -30%, Off	SP3.11
		Overvoltage Alarm Delay	1.0 sec	1.0-30.0 sec	
		Overvoltage Trip Level	Off	5-30%, Off	SP3.12
		Overvoltage Trip Delay	2.0 sec	1.0-30.0 sec	
		Undervoltage Alarm Level	Off	5-30%, Off	SP3.13
		Undervoltage Alarm Delay	1.0 sec	1.0-30.0 sec	
		Undervoltage Trip Level	Off	5-30%, Off	SP3.14
		Undervoltage Trip Delay	2.0 sec	1.0-30.0 sec	
		Line Frequency Trip Window	Disabled	0-6 Hz, Disabled	SP3.15
		Line Frequency Trip Delay	1.0 sec	1.0-20.0 sec	
		P/F Lead P/F Alarm	Off	0.1-1.00, Off	SP3.16
		P/F Lead Alarm Delay	1.0 sec	1-120 sec	
P/F Lead P/F Trip	Off	.01-1.00, Off	SP3.17		
P/F Lead Trip Delay	1.0 sec	1-120 sec			
P/F Lag P/F Alarm	Off	.01-1.00, Off	SP3.18		
P/F Lag Alarm Delay	1.0 sec	1-120 sec			
P/F Lag P/F Trip	Off	.01-1.00, Off	SP3.19		
P/F Lag Trip Delay	1.0 sec	1-120 sec			
Power Demand Period	10 min	1 - 60 min	SP3.20		
KW Demand Alarm Pickup	Off KW	Off, 1-100000			
KVA Demand Alarm Pickup	Off KVA	Off, 1-100000			
KVAR Demand Alarm Pickup	Off KVAR	Off, 1-100000			
Amps Demand Alarm Pickup	Off Amps	Off, 1-100000			

*Ground Fault Option must be installed

Chapter 5 - Setpoint Programming

5.1.4 Relay Assignments (Setpoint Page 4)

Setpoint Page	Security Level	Description	Factory Setting			Range	Section
			1st	2nd	3rd		
Page 4 Relay Assignments	Level 2 Password Protection	O/L Trip	Trip Only	None	None	None Trip(AUX1) Alarm(AUX2) AUX3 AUX4 AUX5-8 Only Available in 8 Relay System Notes: AUX1 to AUX4 are for Factory Use only. Do not change! Only AUX 5 - 8 are used in the 2nd & 3rd relay assignments.	SP4.1
		I/B Trip	Trip	None	None		
		S/C Trip	Trip Only	None	None		
		Overcurrent Trip	Trip	None	None		
		Stator RTD Trip	Trip	None	None		
		Bearing RTD Trip	Trip	None	None		
		*G/F Hi Set Trip	Trip	None	None		
		*G/F Lo Set Trip	Trip	None	None		
		Phase Loss Trip	Trip	None	None		
		Accel. Time Trip	Trip Only	None	None		
		Start Curve Trip	Trip Only	None	None		
		Over Frequency Trip	Trip	None	None		
		Under Frequency Trip	Trip	None	None		
		I*I*T Start Curve	Trip	None	None		
		Learned Start Curve	Trip	None	None		
		Phase Reversal	Trip	None	None		
		Overvoltage Trip	Trip	None	None		
		Undervoltage Trip	Trip	None	None		
		Power Factor Trip	Trip	None	None		
		Tach Accel Trip	None	None	None		
		Inhibits Trip	Trip	None	None		
		TCB Fault	Trip	None	None		
		External Input #2	None	None	None		
		Dual Ramp	None	None	None		
		Thermostat	Trip	None	None		
		O/L Warning	Alarm	None	None		
		Overcurrent Alarm	Alarm	None	None		
		SCR Fail Shunt Alarm	None	None	None		
		*Ground Fault Alarm	Alarm	None	None		
		Under Current Alarm	None	None	None		
		Motor Running	AUX3	None	None		
		I/B Alarm	Alarm	None	None		
		Stator RTD Alarm	None	None	None		
Non-Stator RTD Alarm	None	None	None				
RTD Failure Alarm	None	None	None				
Self Test Fail	Trip	None	None				
Thermal Register	Alarm	None	None				
U/V Alarm	Alarm	None	None				
O/V Alarm	Alarm	None	None				
Power Factor Alarm	None	None	None				
KW Demand Alarm	None	None	None				
KVA Demand Alarm	None	None	None				
KVAR Demand Alarm	None	None	None				
Amps Demand Alarm	None	None	None				
Timed Output	None	None	None				
Run Delay Time	None	None	None				
At Speed	AUX4	None	None				

Chapter 5 - Setpoint Programming

5.1.5 Relay Configuration (Setpoint Page 5)

Setpoint Page	Security Level	Description	Factory Setting Default	Range	Section
Page 5 Relay Configuration	Level 2 Password Protection	Trip (AUX1) Fail-Safe	No	Yes or No	SP5.1
		Trip (AUX1) Relay Latched	Yes	Yes or No	SP5.2
		Alarm (AUX2) Fail-Safe	No	Yes or No	SP5.1
		Alarm (AUX2) Relay Latched	No	Yes or No	SP5.2
		AUX3 Relay Fail-Safe	No	Yes or No	SP5.1
		AUX3 Relay Latched	No	Yes or No	SP5.2
		AUX4 Relay Fail-Safe	No	Yes or No	SP5.1
		AUX4 Relay Latched	No	Yes or No	SP5.2
		AUX5 Relay Fail-Safe	No	Yes or No	SP5.1
		AUX5 Relay Latched	No	Yes or No	SP5.2
		AUX6 Relay Fail-Safe	No	Yes or No	SP5.1
		AUX6 Relay Latched	No	Yes or No	SP5.2
		AUX7 Relay Fail-Safe	No	Yes or No	SP5.1
		AUX7 Relay Latched	No	Yes or No	SP5.2
		AUX8 Relay Fail-Safe	No	Yes or No	SP5.1
		AUX8 Relay Latched	No	Yes or No	SP5.2

Chapter 5 - Setpoint Programming

5.1.6 User I/O Configuration (Setpoint Page 6)

Setpoint Page	Security Level	Description	Factory Setting Default	Range	Section
Page 6 User I/O Configuration	Level 2 Password Protection	Tachometer Scale Selection	Disabled	Enabled or Disabled	SP6.1
		Manual Tach Scale 4.0 mA:	0 RPM	0 - 3600	
		Manual Tach Scale 20.0 mA:	2000 RPM	0 - 3600	
		Tach Accel Trip Mode Select	Disabled	Underspeed, Overspeed or Disabled	SP6.2
		Tach Ramp Time	20 sec	1 - 120	
		Tach Underspeed Trip PT	1650 RPM	0-3600	
		Tach Overspeed Trip PT	1850 RPM	0 - 3600	
		Tach Accel Trip Delay	1 sec	1 - 60	
		Analog Output #1	RMS Current	Off, RPM 0-3600, Hottest Non-Stator RTD 0-200°C, Hottest Stator RTD 0 - 200°C, RMS Current 0 - 7500 A, % Motor Load 0 - 600%, kw 0 - 30000kw.	SP6.3
		Analog Output #1 4mA:	0	0-65535	
		Analog Output #1 20mA:	250	0-65535	
		Analog Output #2	% Motor Load	Same As Analog Input #1	SP6.4
		Analog Output #2 4mA:	0	0-1000%	
		Analog Output #2 20mA:	1000	0-1000%	
		User Programmable External Inputs			SP6.5
		TCB Fault	Enabled	Enabled or Disabled	
		Name Ext. Input #1	TCB Fault	User Defined, up to 15 Characters	
		TCB Fault Type	NO	Normally Open or Closed	
		TCB Fault Time Delay	1 sec	0-60 sec	
		External Input #2	Disabled	Enabled or Disabled	
		Name Ext. Input #2		User Defined, up to 15 Characters	
		External Input #2 Type	NO	Normally Open or Closed	
		External Input #2 Time Delay	0 sec	0-60 sec	
		Second Ramp	Dual Ramp	Enabled or Disabled or Dual Ramp	
		Name Ext. Input #3	Second Ramp	User Defined, up to 15 Characters	
		Second Ramp Type	NO	Normally Open or Closed	
		Second Ramp Time Delay	0 sec	0-60 sec	
		Thermostat	Enabled	Enabled or Disabled	
Name Ext. Input #4	Thermostat	User Defined, up to 15 Characters			
Thermostat Type	NC	Normally Open or Closed			
Thermostat Time Delay	1 sec	0-60 sec			

Chapter 5 - Setpoint Programming

5.1.7 Custom Acceleration Curve (Setpoint Page 7)

Setpoint Page	Security Level	Description	Factory Setting Default	Range	Section
Page 7 Custom Acceleration Curve	Level 3 Password Protection	Custom Accel Curve	Disabled	Disabled, Curve A, B, or C	SP7.1
		Custom Curve A			
		Curve A Voltage Level 1	25%	0-100%	
		Curve A Ramp Time 1	2 sec	1-60 sec	
		Curve A Voltage Level 2	30%	0-100%	
		Curve A Ramp Time 2	2 sec	1-60 sec	
		Curve A Voltage Level 3	37%	0-100%	
		Curve A Ramp Time 3	2 sec	1-60 sec	
		Curve A Voltage Level 4	45%	0-100%	
		Curve A Ramp Time 4	2 sec	1-60 sec	
		Curve A Voltage Level 5	55%	0-100%	
		Curve A Ramp Time 5	2 sec	1-60 sec	
		Curve A Voltage Level 6	67%	0-100%	
		Curve A Ramp Time 6	2 sec	1-60 sec	
		Curve A Voltage Level 7	82%	0-100%	
		Curve A Ramp Time 7	2 sec	1-60 sec	
		Curve A Voltage Level 8	100%	0-100%	
		Curve A Ramp Time 8	2 sec	1-60 sec	
		Curve A Current Limit	350% FLA	200-600%	
		Custom Curve B		Same Programmable Data Points and Ranges as Custom Curve A	
Custom Curve C		Same Programmable Data Points and Ranges as Custom Curve A			

5.1.8 Overload Curve Configuration (Setpoint Page 8)

Setpoint Page	Security Level	Description	Factory Setting Default	Range	Section
Page 8 Overload Curve Configuration	Level 3 Password Protection	Basic Run Overload Curve			SP8.1
		Run Curve Locked Rotor Time	O/L Class	1-30 sec, O/L Class	
		Run Locked Rotor Current	600% FLA	400-800%	
		Coast Down Timer	Disabled	1-60 Min, Disabled	
		Basic Start Overload Curve			SP8.2
		Start Curve Locked Rotor Time	O/L Class	1-30 sec, O/L Class	
		Start Locked Rotor Current	600% FLA	400-800%	
		Acceleration Time Limit	30 sec	1-300 sec, Disabled	
		Number of Starts Per Hour	Disabled	1-6, Disabled	
		Time Between Starts Time	Disabled	1-60 Min, Disabled	
		Area Under Curve Protection	Disabled	Enabled or Disabled	SP8.3
		Max I ² *T Start	368 FLA	1-2500 FLA*FLA*sec	
		Current Over Curve	Disabled	Disabled, Learn, Enabled	SP8.4
		Learned Start Curve Bias	10%	5-40%	
		Time for Sampling	30 sec	1-300 sec	

Chapter 5 - Setpoint Programming

5.1.9 RTD Option Configuration (Setpoint Page 9)

Setpoint Page	Security Level	Description	Factory Setting Default	Range	Section
Page 9 RTD Configuration	Level 3 Password Protection	Use NEMA Temp for RTD Values	Disabled	Enabled or Disabled	SP9.1
		# of RTD Used for Stator	4	0-6	SP9.2
		RTD Voting	Disabled	Enabled or Disabled	SP9.3
		Stator Phase A1 Type	Off	120 OHM NI, 100 OHM NI, 100 OHM PT, 10 OHM CU	SP9.4
		RTD #1 Description	Stator A1	User defined, Up to 15 Characters	
		Stator Phase A1 Alarm Level	Off	0-240C (32-464F), Off	
		Stator Phase A1 Trip Level	Off	0-240C (32-464F), Off	
		Stator Phase A2 Type	Off	Same as Stator Phase A1	
		RTD #2 Description	Stator A2	User defined, Up to 15 Characters	
		Stator Phase A2 Alarm	Off	0-240C (32-464F), Off	
		Stator Phase A2 Trip Level	Off	0-240C (32-464F), Off	
		Stator Phase B1 Type	Off	Same as Stator Phase A1	
		RTD #3 Description	Stator B1	User defined, Up to 15 Characters	
		Stator Phase B1 Alarm Level	Off	0-240C (32-464F), Off	
		Stator Phase B1 Trip Level	Off	0-240C (32-464F), Off	
		Stator Phase B2 Type	Off	Same as Stator Phase A1	
		RTD #4 Description	Stator B2	User defined, Up to 15 Characters	
		Stator Phase B2 Alarm Level	Off	0-240C (32-464F), Off	
		Stator Phase B2 Trip Level	Off	0-240C (32-464F), Off	
		Stator Phase C1 Type	Off	Same as Stator Phase A1	
		RTD #5 Description	Stator C1	User defined, Up to 15 Characters	
		Stator Phase C1 Alarm Level	Off	0-240C (32-464F), Off	
		Stator Phase C1 Trip Level	Off	0-240C (32-464F), Off	
		Stator Phase C2 Type	Off	Same as Stator Phase A1	
		RTD #6 Description	Stator C2	User defined, Up to 15 Characters	
		Stator Phase C2 Alarm Level	Off	0-240C (32-464F), Off	
		Stator Phase C2 Trip Level	Off	0-240C (32-464F), Off	
		End Bearing Type	Off	Same as Stator A1	
		RTD #7 Description	End Bearing	User defined, Up to 15 Characters	
		End Bearing Alarm Level	Off	0-240C (32-464F), Off	
		End Bearing Trip Level	Off	0-240C (32-464F), Off	
		Shaft Bearing Type	Off	Same as Stator Phase A1	
RTD #8 Description	Shaft Bearing	User defined, Up to 15 Characters			
Shaft Bearing Alarm Level	Off	0-240C (32-464F), Off			
Shaft Bearing Trip Level	Off	0-240C (32-464F), Off			
RTD #9 Type	Off	Same as Stator Phase A1			
RTD #9 Description	User defined	User defined, Up to 15 Characters			
RTD #9 Alarm Level	Off	0-240C (32-464F), Off			
RTD #9 Trip Level	Off	0-240C (32-464F), Off			

Chapter 5 - Setpoint Programming

5.1.9 RTD Option Configuration Page 9 Cont'd

Setpoint Page	Security Level	Description	Factory Setting Default	Range	Section
Page 9 RTD Configuration	Level 3 Password Protection	RTD #10 Type	Off	Same as Stator Phase A1	SP9.4
		RTD #10 Description	User defined	User defined, Up to 15 Characters	
		RTD #10 Alarm Level	Off	0-240C (32-464F), Off	
		RTD #10 Trip Level	Off	0-240C (32-464F), Off	
		RTD #11 Type	Off	Same as Stator Phase A1	
		RTD #11 Description	User defined	User defined, Up to 15 Characters	
		RTD #11 Alarm Level	Off	0-240C (32-464F), Off	
		RTD #11 Trip Level	Off	0-240C (32-464F), Off	
		RTD #12 Type	Off	Same as Stator Phase A1	
		RTD #12 Description	User defined	User defined, Up to 15 Characters	
		RTD #12 Alarm Level	Off	0-240C (32-464F), Off	
		RTD #12 Trip Level	Off	0-240C (32-464F), Off	

5.1.10 Security Set Password Page 10

Setpoint Page	Security Level	Description	Factory Setting Default	Range	Section
Page 10	Level 3	Set Level 2 Password	100	000 – 999 Three Digits	SP10.1
		Set Level 3 Password	1000	0000 – 9999 Four Digits	SP10.2

5.1.11 Communications Page 11

Setpoint Page	Security Level	Description	Factory Setting Default	Range	Section
Page 11 Communications	Level 3 Password Protection	Set Front Baud Rate	9.6 KB/sec	2.4, 4.8, 9.6, 19.2, 38.4 KB/sec	SP11.1
		Set Modbus Baud Rate	9.6 KB/sec	2.4, 4.8, 9.6, 19.2, 38.4 KB/sec	SP11.2
		Modbus Address Number	247	1 – 247	SP11.3
		Set Access Code	1	1 – 999	SP11.4
		Set Link Baud Rate	38.4 KB/sec	2.4, 4.8, 9.6, 19.2, 38.4 KB/sec	SP11.5
		Remote Start/Stop	Disabled	Enabled or Disabled	SP11.6

Chapter 5 - Setpoint Programming

5.1.12 System (Setpoint Page 12)

Setpoint Page	Security Level	Description	Factory Setting Default	Range	Section
Page 12 System Setpoints	Level 3 Password Protection	Default Display Screen			SP12.1
		Metering Data Page #	1	Enter Metering Page (1-4)	
		Metering Data Screen #	1	Enter Metering Screen Page 1(1-10) Page 2 (1-11) Page 3 (1 - 29) Page 4 (1 - 6)	
		Alarms			
		RTD Failure Alarm	Disabled	Enabled or Disabled	SP12.2
		Thermal Register Alarm	90%	Off, 40-95%	
		Thermal Alarm Delay	10 sec	1-20 sec	
		Thermal Register Setup Info			SP12.3
		Cold Stall Time	O/L Class	O/L Class (5-30) or 4-40 second time delay	
		Hot Stall Time	½ O/L Class	½ O/L Class, 4-40 sec	
		Stopped Cool Down Time	30 Min	10-300 Min	
		Runing Cool Down Time	15 Min	10-300 Min	
		Relay Measured Cool Rates	Disabled	Enabled or Disabled	
		Thermal Register Minimum	15%	10-50%	
		Motor Design Ambient Temp	40C	10-90C	
		Motor Design Run Temperature	80% Max	50-100% of Motor Stator Max Temp	
		Motor Stator Max Temp	INS CLS	INS CLS, 10-240 C	
		I/B Input to Thermal Register	Enabled	Enabled Only	
		Use Calculated K or Assign	7	1-50, On	
		Press Enter to Clr Thermal Register			SP12.4

5.1.13 Calibration and Service (Setpoint Page 13)

Setpoint Page	Security Level	Description	Factory Setting Default	Range	Section
Page 13 Calibration & Service	FACTORY USE ONLY	Set Date and Time (DDMMYY:HHMM)	FACTORY SET; ##/##/## #:##		SP13.1
		Enter Date (DDMMYYYY)	FACTORY SET; ##/##/####	D=1-31, M=1-12, Y=1970-2069	
		Enter Time (HH:MM)	FACTORY SET; ##:##	H=00-23, M=0-59	
		Model # Firmware REV. #	FACTORY SET; #####	Display Only, Cannot be changed	SP13.2
		Press Enter to Access Factory Settings		Available to Qualified Factory Personnel	SP13.3

Chapter 5 - Setpoint Programming

5.2 Setpoint Menu

Note:

1. Push MENU key to toggle the screens between Setpoint Menu and Metering Menu.
2. Follow the arrow keys to get to different screens.
Example: For Page 3 PHASE & GROUND SETTINGS, press the MENU key and the DOWN ARROW two times.

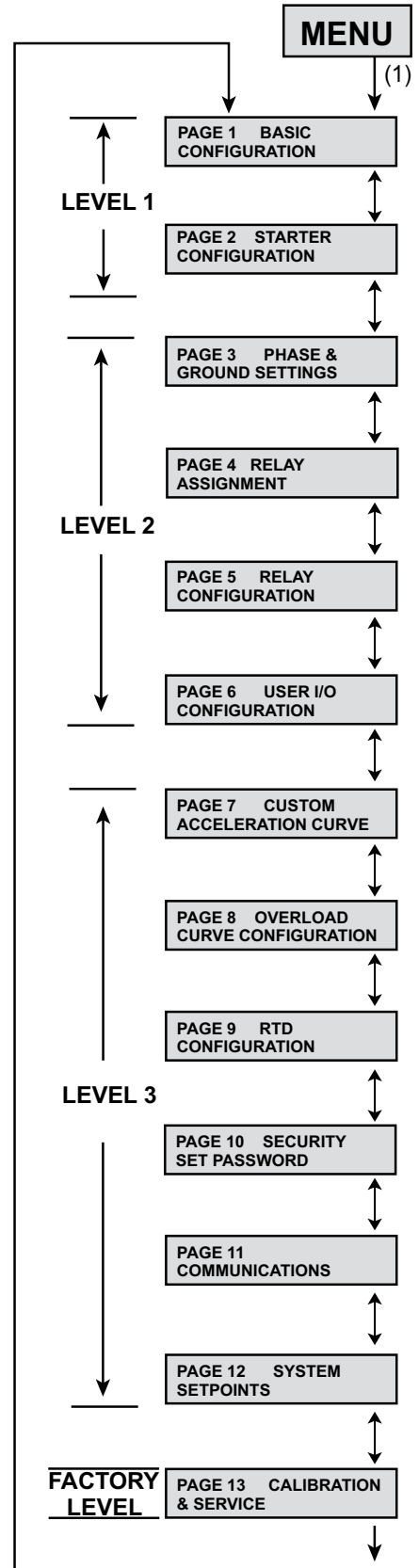

Chapter 5 - Setpoint Programming

SP.1 Basic Configuration (Setpoint Page 1)

In Setpoint Page 1, the **SSM** is looking for the following basic nameplate data of the motor.

SP1.1 Motor Full Load Amps (FLA): Allows the user to enter the motor's FLA rating. Range of adjustment is 50 - 100% (less programmed service factor).

SP1.2 Service Factor: Sets the pickup point on the overload curve as defined by the programmed motor full load current. Ex: If the motor FLA is 100 and the service factor is 1.15, the **SSM** overload pickup point will be 115 Amps.

SP1.3 Overload Class: Choose the motor protection overload class, range from 5-30. Ex: Overload Class 10 will trip in 10 seconds at six times FLA.

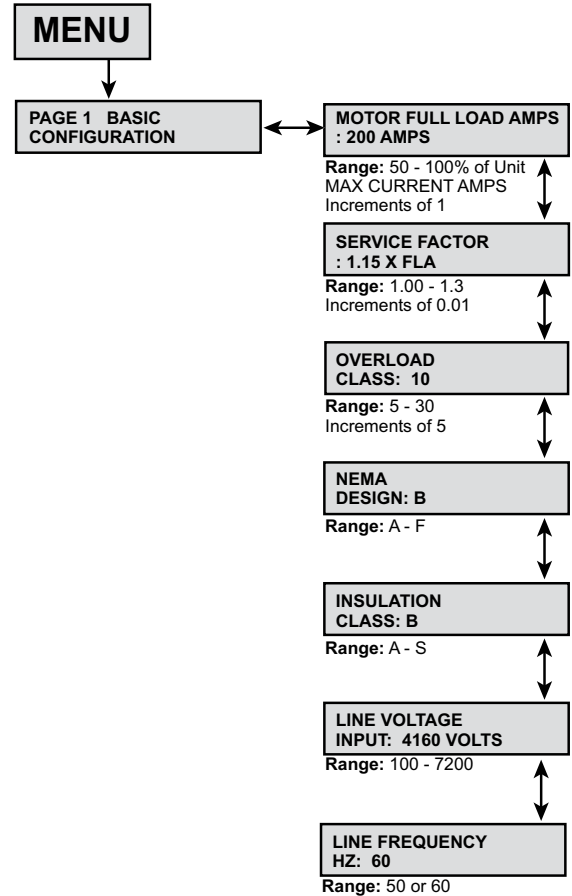
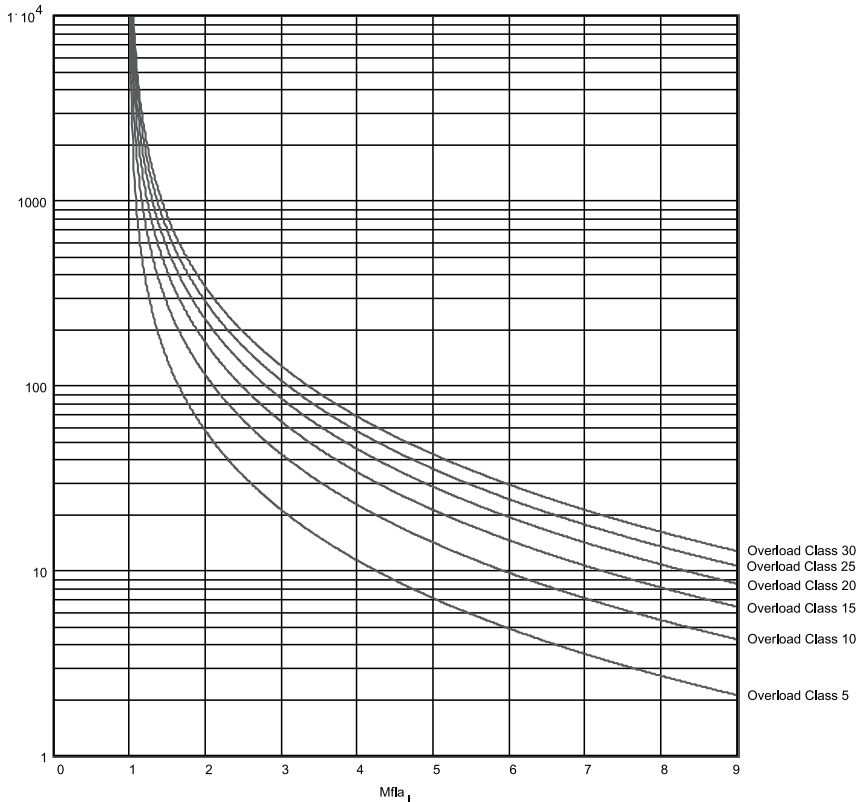

SP1.4 NEMA design: The motor design maximum allowed slip (Select from Class A through F).

SP1.5 Insulation Class: The motor insulation temperature class (Select A, B, C, E, F, G, H, K, N or S).

SP1.6 Line Voltage Input: Applied Voltage

SP1.7 Line Frequency: The user may choose either 50 Hz or 60 Hz.

Chapter 5 - Setpoint Programming

SP.2 Starter Configuration (Setpoint Page 2)

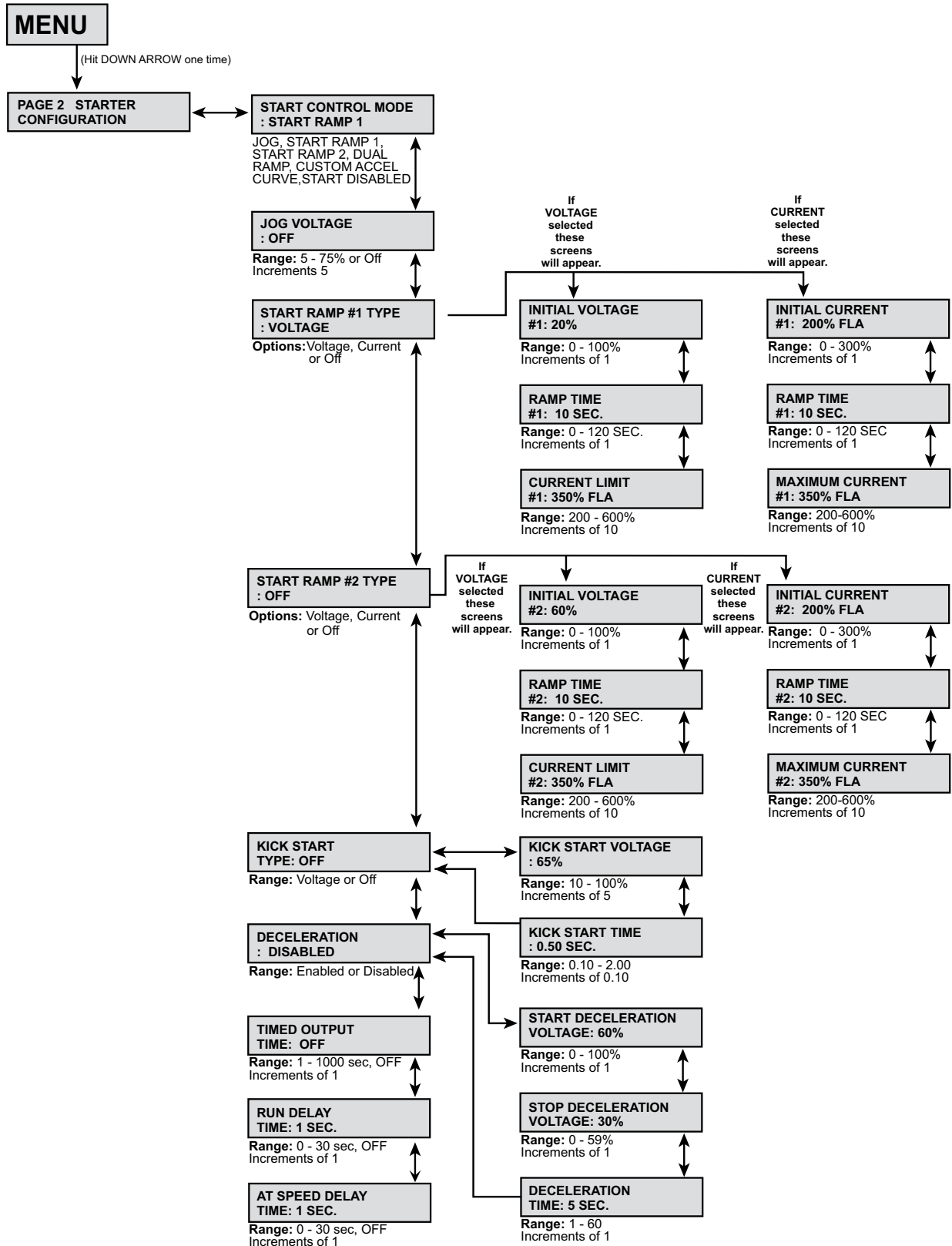

Chapter 5 - Setpoint Programming

SP.2 Starter Configuration (Setpoint Page 2)

Provides multiple choices for starting ramps that can be selected for particular loads and applications.

SP2.1 Start Control Mode: Dual Ramp, Custom Accel Curve, Jog Voltage, Start Ramp 1, Start Ramp 2.

- **Dual Ramp:** The dual ramp mode works in conjunction with External Input #3. This allows the user to switch between the two start ramps without having to reconfigure the start mode. (For details on configuring External Input #3 for DUAL RAMP see Setpoint Page 6.)
- **Custom Accel Curve:** Allows the user to custom design the acceleration start curve to the application. (See setpoint page 7 for configuration setup.) *Note:* If Custom Accel Curve has not been enabled in setpoint page 7, the **SSM** will ignore the start control mode and read this setpoint as disabled.
- **Tach Ramp:** See setpoint page 6 for configuration setup of tachometer input. (Pending)

SP2.2 Jog Voltage: The voltage level necessary to cause the motor to slowly rotate.

SP2.3 Start Ramp 1 Type: The ramp type can be setup for either Voltage or Current. If Voltage is selected, initial voltage, ramp time and current limit are adjustable. If Current is selected, initial current, ramp time and maximum current are adjustable.

Start Ramp 1 Type: Voltage

- **Voltage Ramping** is the most reliable starting method, because the starter will eventually reach an output voltage high enough to draw full current and develop full torque. This method is useful for applications where the load conditions change frequently and where different levels of torque are required. Typical applications include material handling conveyors, positive displacement pumps and drum mixers.

Voltage is increased from a starting point (Initial Torque) to full voltage over an adjustable period of time (Ramp Time). To achieve Voltage Ramping, select VOLTAGE for the START RAMP #1 TYPE setpoint and set CURRENT LIMIT#1 setpoint to 600% (the maximum setting). Since this is essentially Locked Rotor Current on most motors, there is little or no

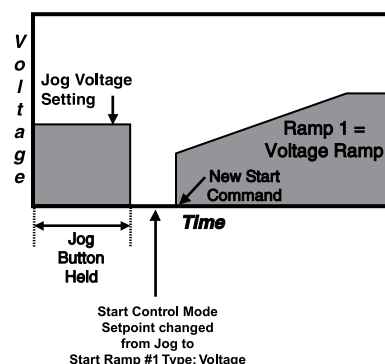

Current Limit effect on the Ramp profile.

- **Voltage Ramping with Current Limit** is the most used curve and is similar to voltage ramping. However, it adds an adjustable maximum current output. Voltage is increased gradually until the setting of the Maximum Current Limit setpoint is reached. The voltage is held at this level until the motor accelerates to full speed. This may be necessary in applications where the electrical power is limited. Typical applications include portable or emergency generator supplies, utility power near the end of a transmission line and utility starting power demand restrictions. *Note:* Using Current Limit will override the Ramp Time setting if necessary, so use this feature when acceleration time is not critical. To achieve Voltage Ramping with Current Limit, select VOLTAGE for the START RAMP #1 setpoint and set CURRENT LIMIT#1 setpoint to a desired lower setting, as determined by your application requirements.

Start Ramp 1 Type: Current

- **Current Ramping** (Closed Loop Torque Ramping) is used for smooth linear acceleration of output torque. This ramp is only used on some conveyor systems (long haul or down hill). For other applications, use Voltage Ramp or a custom accel curve. Output voltage is constantly updated to provide the linear current ramp, and therefore the available torque is maximized at any given speed. This is for applications where rapid changes in torque may result in load damage or equipment changes. Typical applications include overland conveyors if belt stretching occurs; fans and mixers if blade warping is a problem; and material handling systems if stacked products fall over or break. This feature can be used with or without the Maximum Current Limit setting. To achieve Current Ramping select CURRENT for START RAMP #1 TYPE setpoint and the MAXIMUM CURRENT #1 setpoint to the desired level.

- **Current Limit Only:** (Current Step) start uses the Current Limit feature exclusively. This method of starting eliminates the soft start voltage/current ramp and instead, maximizes the effective application of motor torque within the limits of the motor. In this mode, setpoint RAMP TIME #1 is set to zero (0), so the output current jumps to the current limit setting immediately. Typically used in with a limited power supply, when starting a difficult load such as a centrifuge or deep well pump, when the motor capacity is barely adequate (stall condition or overloading occurs) or if other starting modes fail. Since ramp times are set to zero (0), START RAMP #1 TYPE is set to either VOLTAGE or CURRENT.

Chapter 5 - Setpoint Programming

- **Initial Torque (Initial Voltage #1 or Initial Current #1):** Sets the initial start point of either the Voltage Ramp or the Current Ramp. Every load requires some amount of torque to start from a standstill. It is inefficient to begin ramping the motor from zero every time, since between zero and the WK2 break-away torque level, no work is being performed. The initial torque level should be set to provide enough torque to start rotating the motor shaft, enabling a soft start and preventing torque shock damage. Setting this start point too high will not damage the starter, but may reduce or eliminate the soft start effect.
- **Ramp Time #1:** Sets the maximum allowable time for ramping the initial voltage or current (torque) setting to either of the following:
 - 1) the Current Limit setting when the motor is still accelerating, or
 - 2) full output voltage if the Current Limit is set to maximum.Increasing the ramp time softens the start process by gradually increasing the voltage or current. Ideally, the ramp time should be set for the longest amount of time the application will allow (without stalling the motor). Some applications require a short ramp time due to the mechanics of the system. (i.e, centrifugal pumps, because pump problems can occur due to insufficient torque).
- **Current Limit:** Sets the maximum motor current the starter will allow during Ramping. As the motor begins to ramp, the Current Limit feature sets a ceiling at which the current draw is held. Current Limit remains in effect until the following occurs:
 - 1) the motor reaches full speed (detected by the At-Speed detection circuit) or
 - 2) the Overload Protection trips on Motor Thermal Overload.Once the motor reaches full speed, the Current Limit feature becomes inactive.

In the Voltage Ramp Profile, the voltage output is increased until it reaches the Current Limit. Ramp time is the maximum amount of time it takes for the voltage to increase until the Current Limit setting takes over. With some load conditions, the Current Limit is reached before the Ramp Time expires.

The Current Ramp profile varies the output voltage to provide a linear increase in current up to the Maximum Current setpoint value. A closed loop feedback of motor current maintains the Current Ramp profile.

SP2.4 Start Ramp 2: The same options and screen

setups as Start Ramp 1. Note: CUSTOM ACCEL CURVE overrides the voltage or current start in Ramps 1 and 2 when selected to be the start control mode.

SP2.5 Kick Start: Used as an initial energy burst in applications with high friction loads.

- **Kick Start Voltage:** The initial voltage (as a percent of full voltage value) that is needed to start the motor. (i.e., Breakaway or Initial Torque.)
- **Kick Start Time:** The time the initial torque boost is applied.

SP2.6 Deceleration: Allows the motor to gradually come to a soft stop.

- **Start Deceleration Voltage:** The first part of the deceleration ramp. The **SSM** initially drops to this voltage level upon receiving a STOP command. (Represented as a percent of voltage value.)
- **Stop Deceleration Voltage:** The drop-off point of the deceleration ramp. (Percent of voltage value.)
- **Deceleration Time:** Decel ramp time.

SP2.7 Timed Output: Used with an AUX 5-8 relay. When enabled, and upon a start command, it waits until the programmed time plus the run delayed time has expired. The relay energizes and remains so until a stop command is received. It de-energizes upon receiving a stop command.

SP2.8 Run Delay Time: Can be used with an AUX 5-8 relay. The delay timer begins upon receipt of the start command. The relay will then drop out when the time has expired.

SP2.9 At Speed Delay Time: Used with an AUX 4 relay, it waits until after the motor reaches the end of ramp and the programmed delay time has expired. The relay energizes until a stop command has been received.

Chapter 5 - Setpoint Programming

SP.3 Phase & Ground Settings

(Setpoint Page 3)

Security Level: 2

(See pg 58 for passwords)

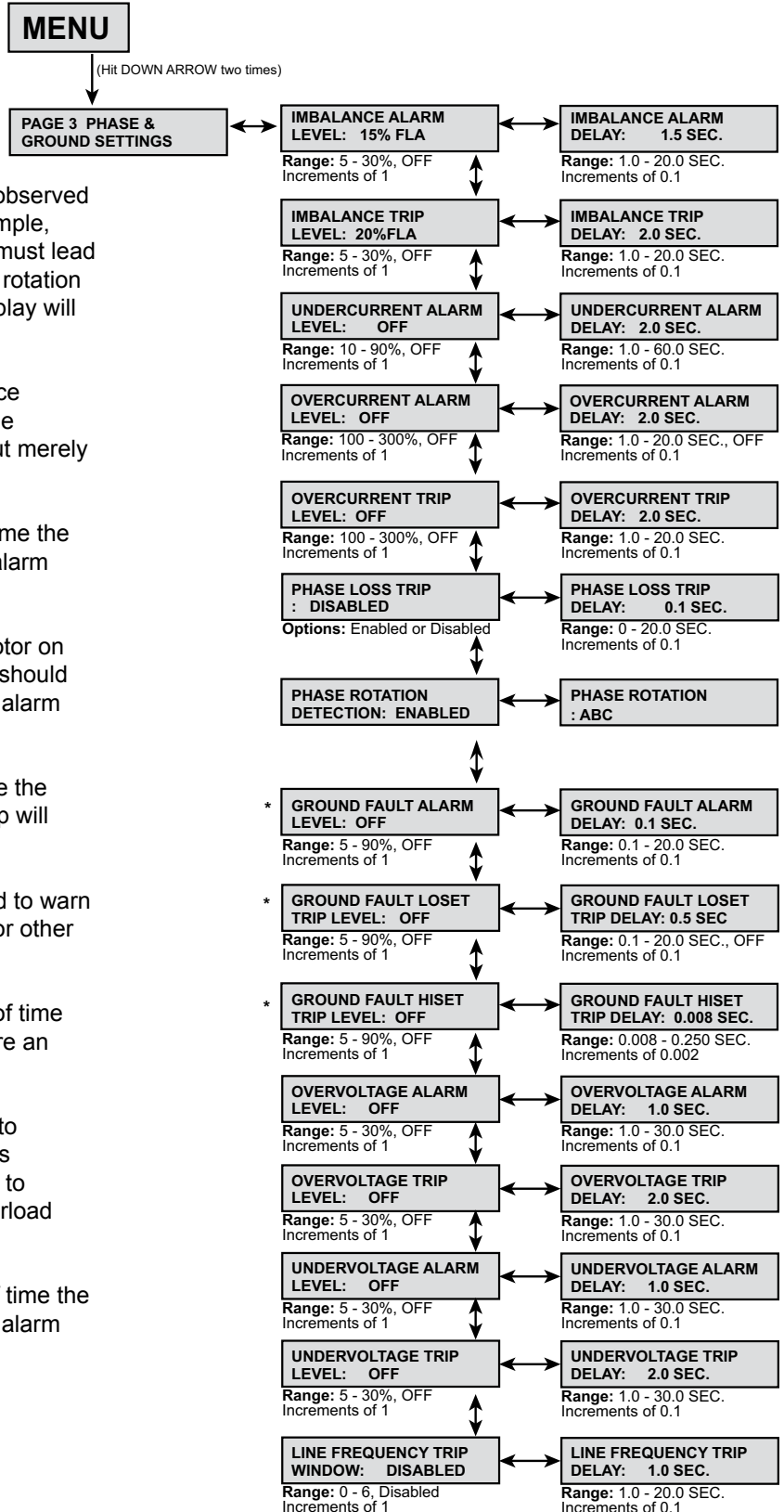

Note: Proper phase sequence must be observed when connecting the input power. For example, phase A must lead phase B, which in turn must lead phase C by 120° respectively. If the phase rotation is not correct, a fault light and the LCD display will indicate the problem.

SP3.1 Imbalance Alarm Level: This is an advance warning of a phase imbalance problem. The problem may not be a fault in the motor, but merely caused by imbalanced voltages.

- **Imbalance Alarm Delay:** The amount of time the imbalance condition must exist before an alarm occurs.

SP3.2 Imbalance Trip Level: This will trip the motor on excessive phase imbalance. The trip level should be programmed to a higher value than the alarm level.

- **Imbalance Trip Delay:** The amount of time the imbalance condition must exist before a trip will occur.

SP3.3 Undercurrent Alarm Level: Typically used to warn of possible load loss, a coupling breaking or other mechanical problems.

- **Undercurrent Alarm Delay:** The amount of time the undercurrent condition must exist before an alarm will occur.

SP3.4 Overcurrent Alarm Level: Typically used to indicate when the motor is overloaded. This feature can be used to either stop the feed to the equipment or warn operators of an overload condition.

- **Overcurrent Alarm Delay:** The amount of time the overcurrent condition must exist before an alarm will occur.

Chapter 5 - Setpoint Programming

SP.3 Phase & Ground Settings (Setpoint Page 3) (Security Level: 2)

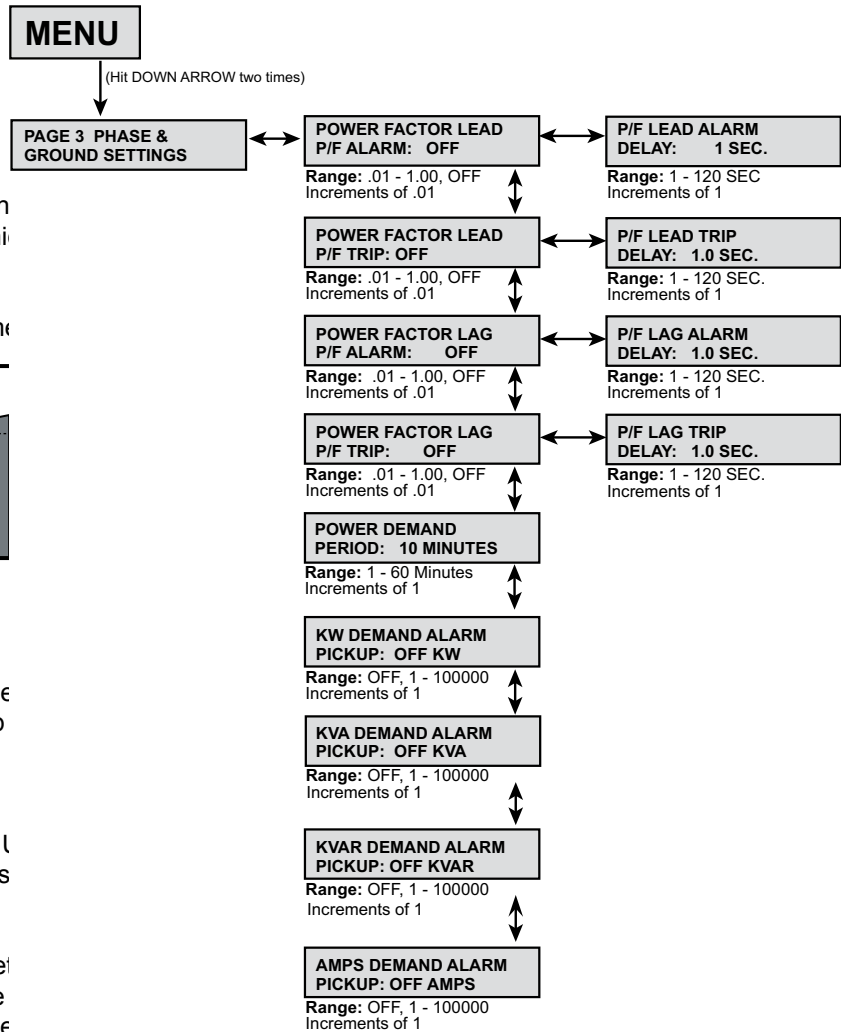

SP3.5 Overcurrent Trip Level: Typically used to trip the motor is severely overloaded and at which point a trip occurs.

- **Overcurrent Trip Delay:** The amount of time the overcurrent condition must exist before a trip will occur.

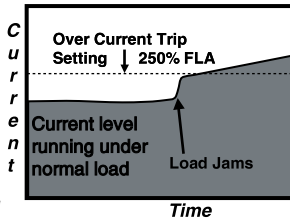

SP3.6 Phase Loss Trip: When enabled, the **SSM** will trip the motor off-line upon a loss of phase power.

- **Phase Loss Trip Delay:** The amount of time phase loss condition must exist before a trip occur.

SP3.7 Phase Rotation Detection: The **SSM** is continuously monitoring the phase rotation. At a start command, a trip will occur if it detects change in the phase rotation.

- **Phase Rotation:** Must be ABC only. This setpoint monitors the wiring to ensure that the phase rotation is correct. To view the present phase rotation, go to Metering Page1, screen number 4 on page 66.

SP3.8 *Ground Fault Alarm: Typically used to warn of low level ground current leakage

- ***Ground Fault Alarm Delay:** The amount of time that the ground fault condition must exist before an alarm will occur.

SP3.9 *Ground Fault Loset Trip Level: Typically used to trip the motor on a low level of ground current leakage. This setpoint is intended to detect high impedance faults.

- ***Ground Fault Loset Trip Delay:** The amount of time that the ground fault condition must exist before a trip will occur.

SP3.10 *Ground Fault Hiset Trip Level: Used to trip the motor (within milliseconds) upon detecting a high level of ground current leakage. This setpoint is intended to detect low impedance faults.

- ***Ground Fault Hiset Trip Delay:** The amount of time that the ground fault condition must exist before a trip will occur.

* Ground Fault Option must be installed

Chapter 5 - Setpoint Programming

SP3.11 Overvoltage Alarm Level: Typically used to indicate when the line voltage is too high. This is an alarm level.

- **Overvoltage Alarm Delay:** The amount of time that the overvoltage condition must exist before a trip will occur.

SP3.12 Overvoltage Trip Level: Typically used to indicate that the line voltage is too high and at which point a trip occurs

- **Overvoltage Trip Delay:** The amount of time that the overvoltage condition must exist before a trip will occur.

SP3.13 Undervoltage Alarm Level: Typically used to indicate when the line voltage is too low. This is an alarm level.

- **Undervoltage Alarm Delay:** The amount of time that the overvoltage condition must exist before a trip will occur.

SP3.14 Undervoltage Trip Level: Typically used to indicate that the line voltage is too low and at which point a trip occurs

- **Undervoltage Trip Delay:** The amount of time that the undervoltage condition must exist before a trip will occur.

SP3.15 Line Frequency Trip Window: The acceptable amount of drift above or below the line frequency (Hz) before a trip is generated.

- **Line Frequency Trip Delay:** The amount of time that the frequency drift condition must exist beyond the window before a trip will occur.

SP3.16 Power Factor Lead Alarm: Typically used to

indicate a leading power factor.

- **Power Factor Lead Alarm Delay:** The amount of time that the power factor lead condition must exist beyond the window before a trip will occur.

SP3.17 Power Factor Lead Trip: The acceptable amount of power factor lead before a trip is generated.

- **Power Factor Lead Delay:** The amount of time that the power factor lead condition must exist beyond the window before a trip will occur.

SP3.18 Power Factor Lag Alarm: Typically used to indicate a lagging power factor.

- **Power Factor Lag Alarm Delay:** The amount of time that the power factor lagging condition must exist beyond the window before a trip will occur.

SP3.19 Power Factor Lag Trip: The acceptable amount of power factor lag before a trip is generated.

- **Power Factor Lag Delay:** The amount of time that the power factor lag condition must exist beyond the window before a trip will occur.

SP3.20 Power Demand Period: The **SSM** measures the demand of the motor for several parameters (current, kW, kVAR, kVA). The demand values of motors assists in energy management programs where processes may be altered or scheduled to reduce overall demand. Demand is calculated by a programmed amount of time where current, kW, kVAR and kVA samples are taken and then averaged and stored to assess demand.

Chapter 5 - Setpoint Programming

SP.4 Relay Assignment (Setpoint Page 4)

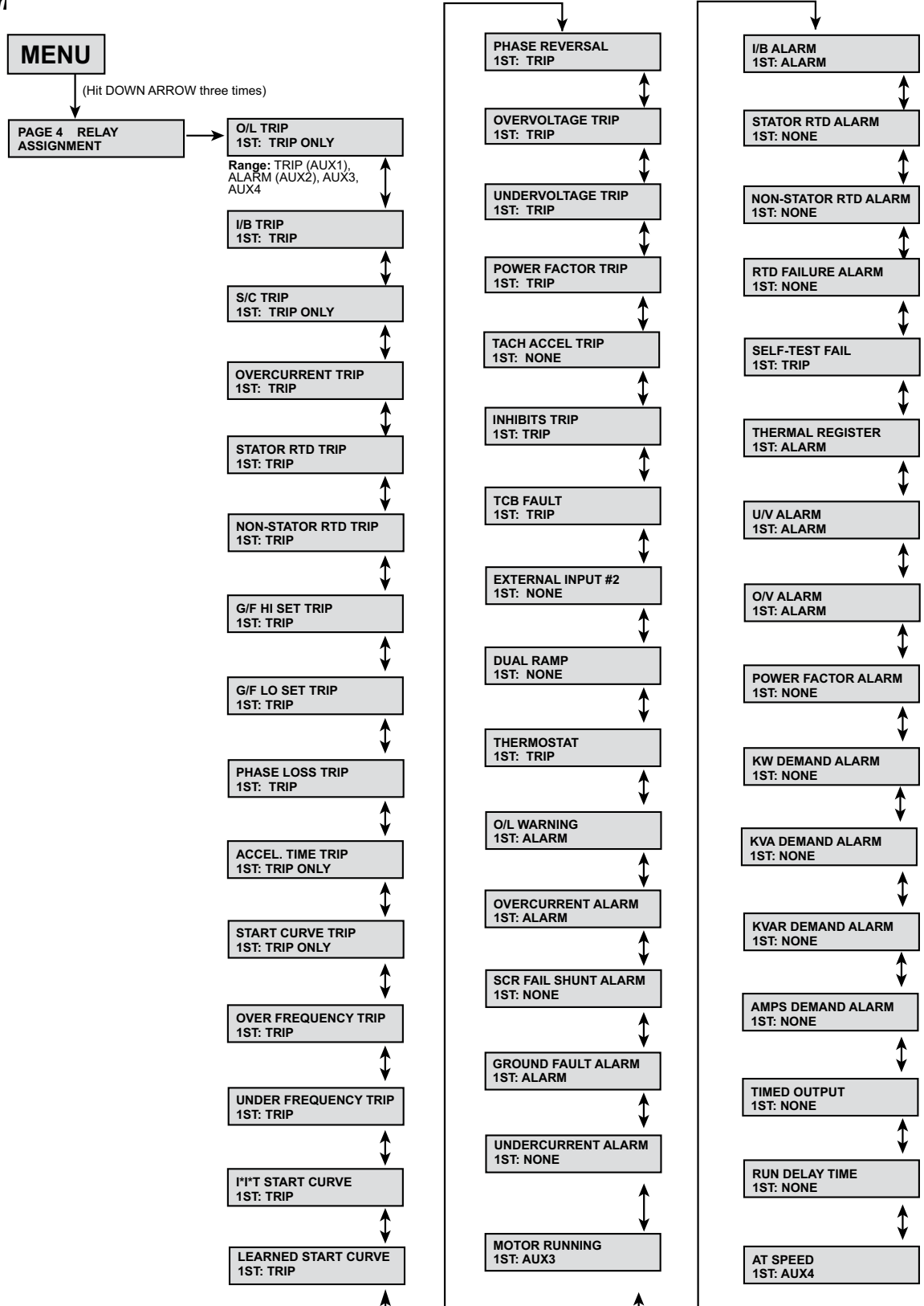

Chapter 5 - Setpoint Programming

SP.4 Relay Assignment (Setpoint Page 4)

(Security Level: 2)

All of the protection functions of the **MVC Plus** are user programmable to an output relay. The factory will ship with all tripping functions assigned to TRIP (AUX1) relay, and all alarm functions to ALARM (AUX2) relay. Note: AUX1 - 4 are Factory Set and should not be changed.

SP4.1 The following is a list of all the user programmable functions.

Note: The 1st Relay Assignments are factory defaults and should not be changed.

FUNCTIONS	RELAY ASSIGNMENTS		
	<u>1st</u>	<u>2nd</u>	<u>3rd</u>
IMBALANCE TRIP	TRIP (AUX1)	NONE	NONE
SHORT CIRCUIT TRIP	TRIP (AUX1)	NONE	NONE
OVERCURRENT TRIP	TRIP (AUX1)	NONE	NONE
STATOR RTD TRIP	TRIP (AUX1)	NONE	NONE
NON-STATOR RTD TRIP	TRIP (AUX1)	NONE	NONE
GROUND FAULT HI SET TRIP*	TRIP (AUX1)	NONE	NONE
GROUND FAULT LO SET TRIP*	TRIP (AUX1)	NONE	NONE
PHASE LOSS TRIP	TRIP (AUX1)	NONE	NONE
OVER FREQUENCY TRIP	TRIP (AUX1)	NONE	NONE
UNDER FREQUENCY TRIP	TRIP (AUX1)	NONE	NONE
I*I*T START CURVE	TRIP (AUX1)	NONE	NONE
LEARNED START CURVE	TRIP (AUX1)	NONE	NONE
PHASE REVERSAL	TRIP (AUX1)	NONE	NONE
OVERVOLTAGE TRIP	TRIP (AUX1)	NONE	NONE
UNDERVOLTAGE TRIP	TRIP (AUX1)	NONE	NONE
POWER FACTOR TRIP	TRIP (AUX1)	NONE	NONE
TACH ACCEL TRIP	NONE	NONE	NONE
INHIBITS TRIP	TRIP (AUX1)	NONE	NONE
TCB FAULT	TRIP (AUX1)	NONE	NONE
EXTERNAL INPUT 2	NONE	NONE	NONE
DUAL RAMP	NONE	NONE	NONE
THERMOSTAT	TRIP (AUX1)	NONE	NONE
OVERLOAD WARNING	ALARM (AUX2)	NONE	NONE
OVERCURRENT ALARM	ALARM (AUX2)	NONE	NONE
SCR FAIL SHUNT ALARM	ALARM (AUX2)	NONE	NONE
GROUND FAULT ALARM*	ALARM (AUX2)	NONE	NONE
UNDERCURRENT ALARM	NONE	NONE	NONE
MOTOR RUNNING	AUX3	NONE	NONE
IMBALANCE ALARM	ALARM (AUX2)	NONE	NONE
STATOR RTD ALARM	NONE	NONE	NONE
NON-STATOR RTD ALARM	NONE	NONE	NONE
RTD FAILURE ALARM	NONE	NONE	NONE
SELF TEST FAIL	TRIP (AUX1)	NONE	NONE
THERMAL REGISTER	ALARM (AUX2)	NONE	NONE
U/V ALARM	ALARM (AUX2)	NONE	NONE
O/V ALARM	ALARM (AUX2)	NONE	NONE
POWER FACTOR ALARM	NONE	NONE	NONE
KW DEMAND ALARM	NONE	NONE	NONE
KVA DEMAND ALARM	NONE	NONE	NONE
KVAR DEMAND ALARM	NONE	NONE	NONE
AMPS DEMAND ALARM	NONE	NONE	NONE
TIMED OUTPUT	NONE	NONE	NONE
RUN DELAY TIME	NONE	NONE	NONE
AT SPEED	AUX4	NONE	NONE

*Ground fault option must be installed

Chapter 5 - Setpoint Programming

SP.5 Relay Configuration (Setpoint Page 5) (Security Level: 2)

In Setpoint Page 5 the user can configure the four output relays as either fail-safe or non fail-safe and latching or non-latching.

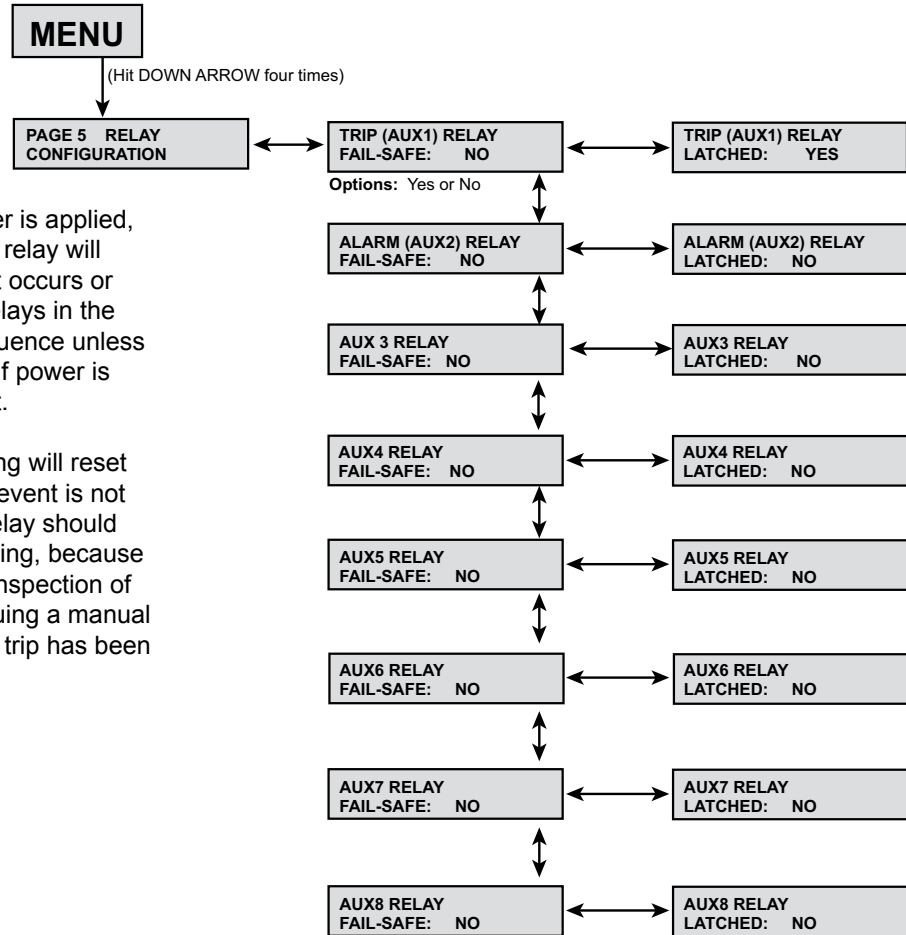

SP5.1 When a relay has been configured as fail-safe and power is applied, the relay will be energized. The relay will then de-energize when an event occurs or if the power fails. *NOTE:* The relays in the **SSM** will not prevent a start sequence unless they are wired in as interlocks. If power is lost, the motor power is also lost.

SP5.2 A relay configured as non-latching will reset itself when the cause of the trip event is not continuous. The TRIP (AUX1) relay should always be programmed for latching, because this trip should require a visual inspection of the motor and starter before issuing a manual reset to release the relay after a trip has been stored.

Chapter 5 - Setpoint Programming

SP.6 User I/O Configuration (Setpoint Page 6) (Security Level: 2)

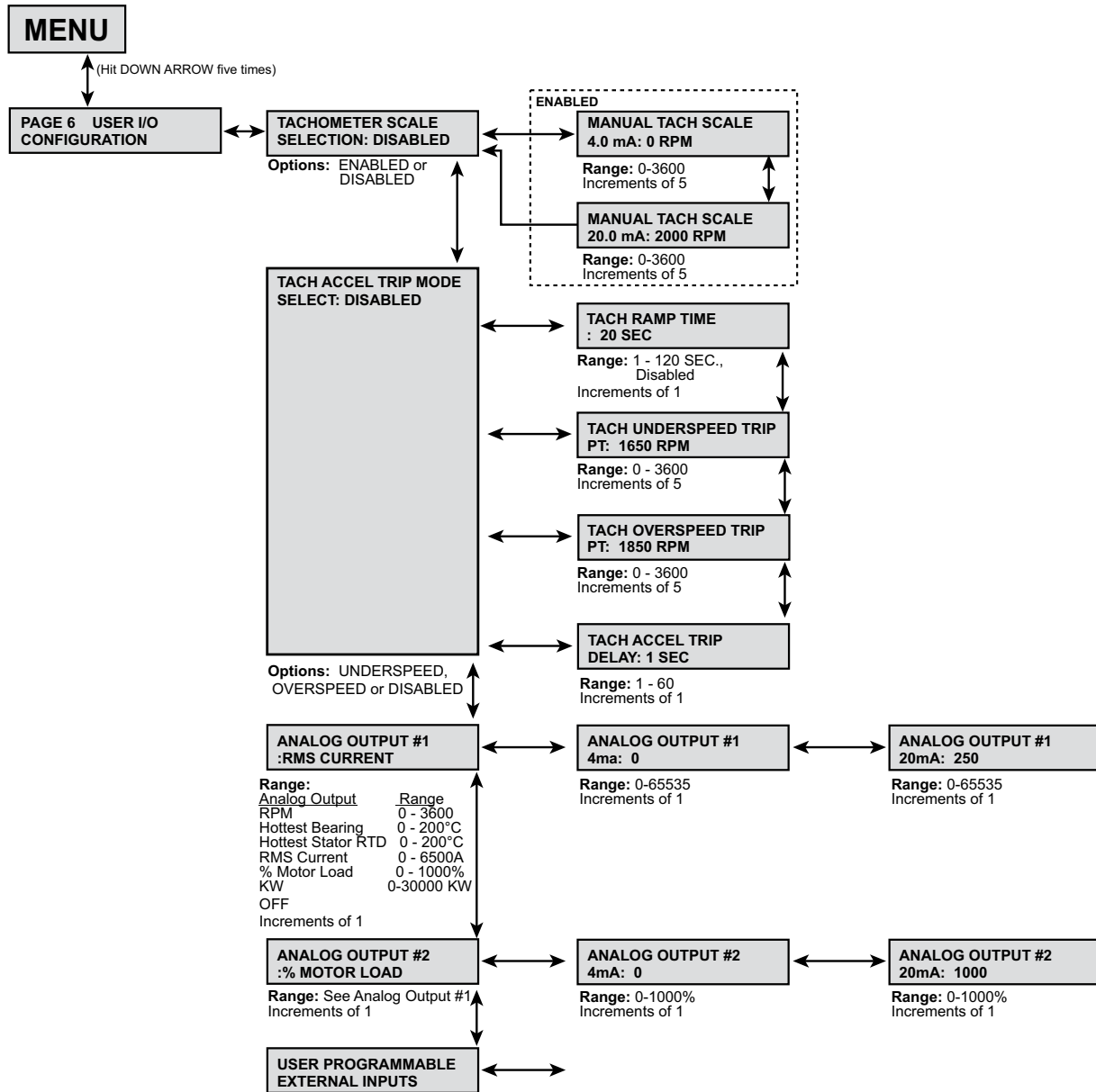

Continued...

Chapter 5 - Setpoint Programming

SP.6 User I/O Configuration (Setpoint Page 6)

(Security Level: 2)

The **SSM** can be configured to accept a tachometer feedback signal through the 4-20mA input.

SP6.1 The first screen of setpoint page 6 is TACHOMETER SCALE SELECTION. When this is set to ENABLED, the user will need to input the tachometer scale of the 4-20mA input range.

- **Manual Tach Scale 4.0 mA:** The unit is looking for an RPM value to assign to the lowest point on the scale. This value should represent the motor at zero speed.
- **Manual Tach Scale 20.0 mA:** The unit is looking for an RPM value to assign to the highest point on the scale. This value should represent the motor at full speed.

SP6.2 Tach Accel Trip Mode Select: When enabled, the underspeed or overspeed must be selected for the Tach Accel Trip. If underspeed is selected, only the Tach Underspeed Trip Point will be used. If overspeed is selected only the Tach Overspeed Trip Point will be used.

- **Tach Ramp Time:** This is the duration of time before the tachometer begins to sample.
- **Tach Underspeed Trip:** The minimum value motor RPM which must be achieved before the Tach Ramp Time sample is taken.
- **Tach Overspeed Trip:** The maximum motor RPM allowed when the Tach Ramp Time sample is taken.
- **Tach Accel Trip Delay:** The duration of time that the Tach Accel trip condition must persist before a trip is generated.

SP6.3 The controller provides two 4-20mA analog outputs. Each analog output is independent of the other and can be assigned to monitor different functions. The available output ranges are RPM, Hottest Non-Stator (Bearing) RTD, Hottest Stator RTD, RMS current, or % Motor Load.

- **Analog Output #1** – Select a function from the available five options to be transmitted from the 4-20mA output. *Note:* If selecting RPM, the Tachometer feedback input signal must be present in order for the controller to give proper output. If selecting RTD, the RTD option must be installed and an RTD input signal must be present for a proper output to be given from the analog output.
- **Analog Output #1 (4 mA):** Enter a value that the 4mA level will represent for the selected function; typically this value should be 0.
- **Analog Output #1 (20 mA):** Enter a value that the 20mA level will represent for the selected function.

SP6.4 Analog Output #2 – All of the setpoints and setup screens for Analog Output #2 are the same as those for Analog Output #1.

Chapter 5 - Setpoint Programming

SP.6 User I/O Configuration (Setpoint Page 6) (Security Level: 2)

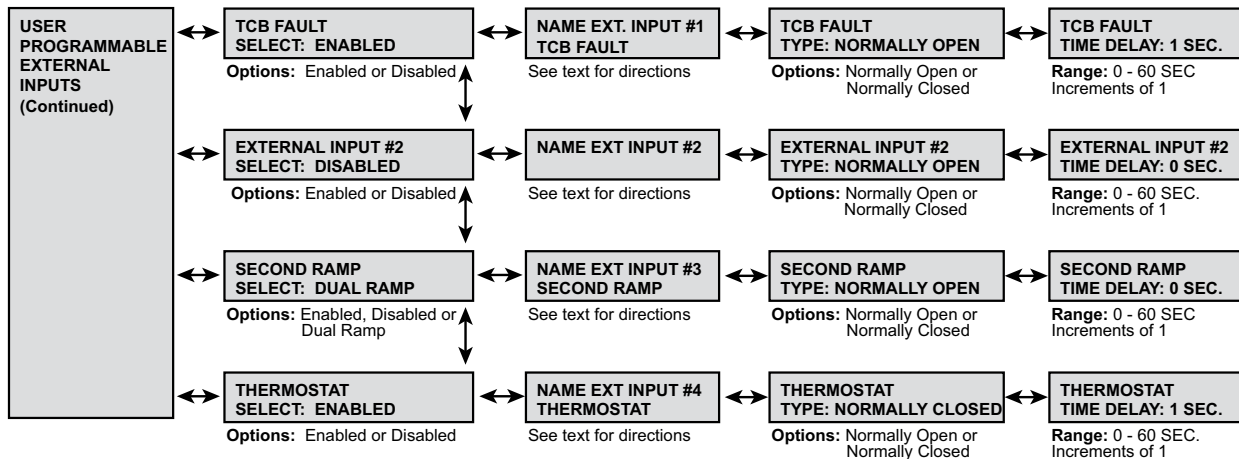

SP6.5 User Programmable External Inputs: The controller provides up to 4 digital external inputs which are individually programmable. A description name can be assigned to each individual input for easy identification.

- **External Input #1:** Factory programmed for TCB Fault.
- **External Input #2:** If used, this setpoint must be enabled.
- **Name Ext. Input #2:** The user can assign a description name to the input to easily identify the cause of external trip or alarm. Up to 15 characters including spaces can be used to assign the name.
- **External Input #2 Type:** The external input can be set as either a normally open or normally closed contact.
- **External Input #2 Time Delay:** Upon a change in contact setting, the unit will wait the programmed amount of time before generating an output. If no delay is needed, then input 0 seconds. The controller will post an event upon seeing a change in state.
- **External Input #3:** The setup screens and setpoints for External Input #3 includes the option of being configured for Dual Ramp. In Dual Ramp mode, the initial contact setting is the same as the START RAMP #1. Upon a change in input contact state, the controller will switch over to START RAMP #2 and use that setting for start control mode. Note: The start RAMP types should only be switched while the motor is stopped. In Setpoint Page 4 Relay Assignments, do not assign any output relay to this function. The controller will ship with External input #3 programmed for dual ramp. If it is not needed, disable the dual ramp.
- **External Input #4** – These input screens are for the thermostat input and can be enabled or disabled. Note: It is recommended that this function remain enabled. If the thermostat indicates an over temperature condition, the controller will trip the motor.

Chapter 5 - Setpoint Programming

SP.7 Custom Acceleration Curve (Setpoint Page 7) (Security Level: 3)

SP7.1 Setpoint Page 7 allows the user to custom design the acceleration curve (start curve) to the specific application. The user can custom design up to three different curves in the **SSM**. Only one curve can be active (enabled) at a time. Each of the three curves allow for eight voltage plotting points, with corresponding ramp times and a current limit setting.

Note: Each successive voltage level must be programmed to a voltage level equal to or greater than the previous level. All eight levels of voltages must be programmed and the eighth level has been preset at 100%.

- If Custom Accel Curve has been set to curve A, B or C on this page, the **SSM** will override the Start Control Mode selected in Setpoint Page 2, (even if Start Control Mode in Setpoint Page 2 has not been set to Custom Accel Curve).

Note: Setpoint Page 7 has a security level 3 requirement (See page 58 for passwords).

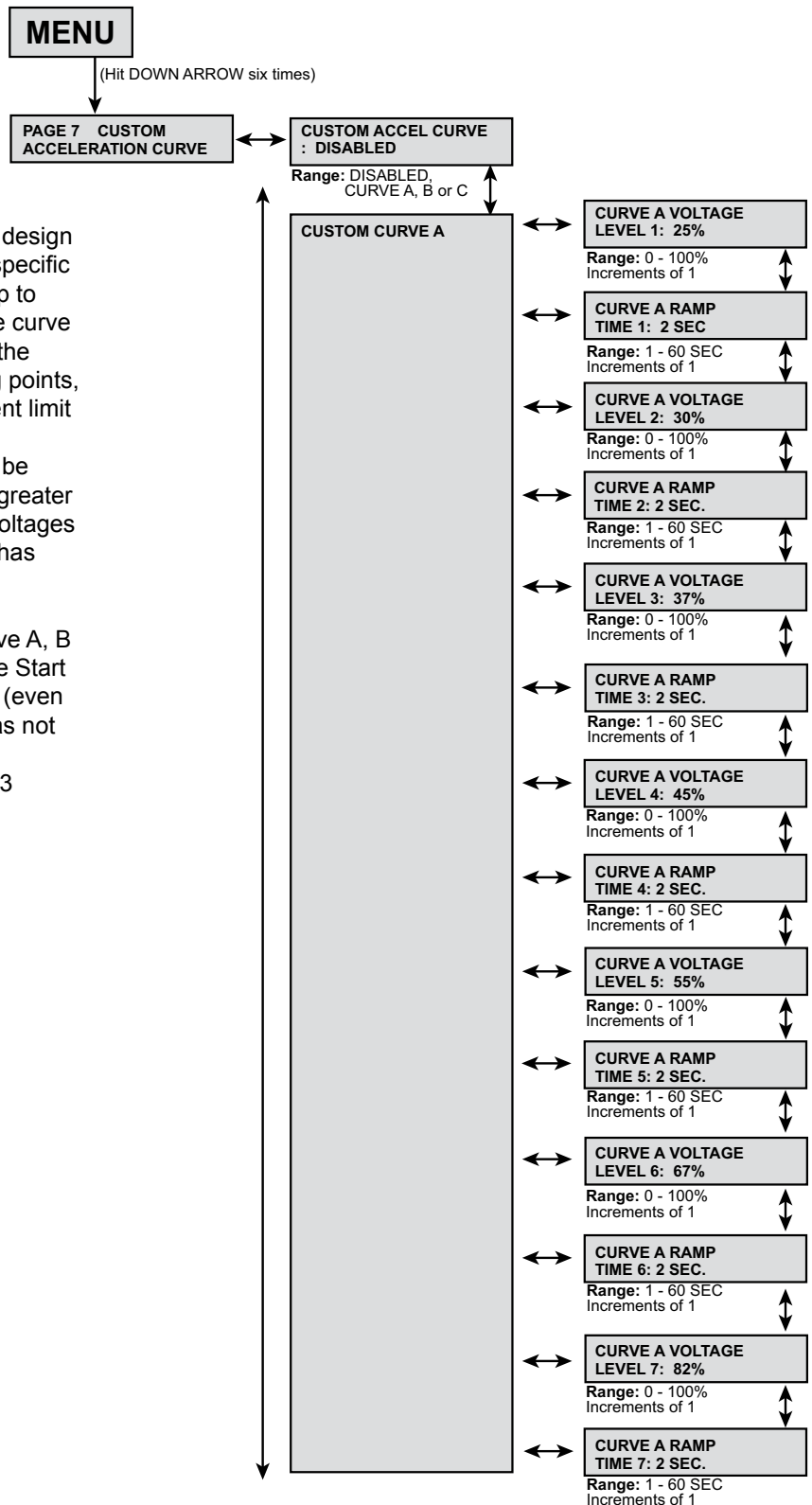

Chapter 5 - Setpoint Programming

SP.7 Custom Acceleration Curve (Setpoint Page 7) (Security Level: 3)

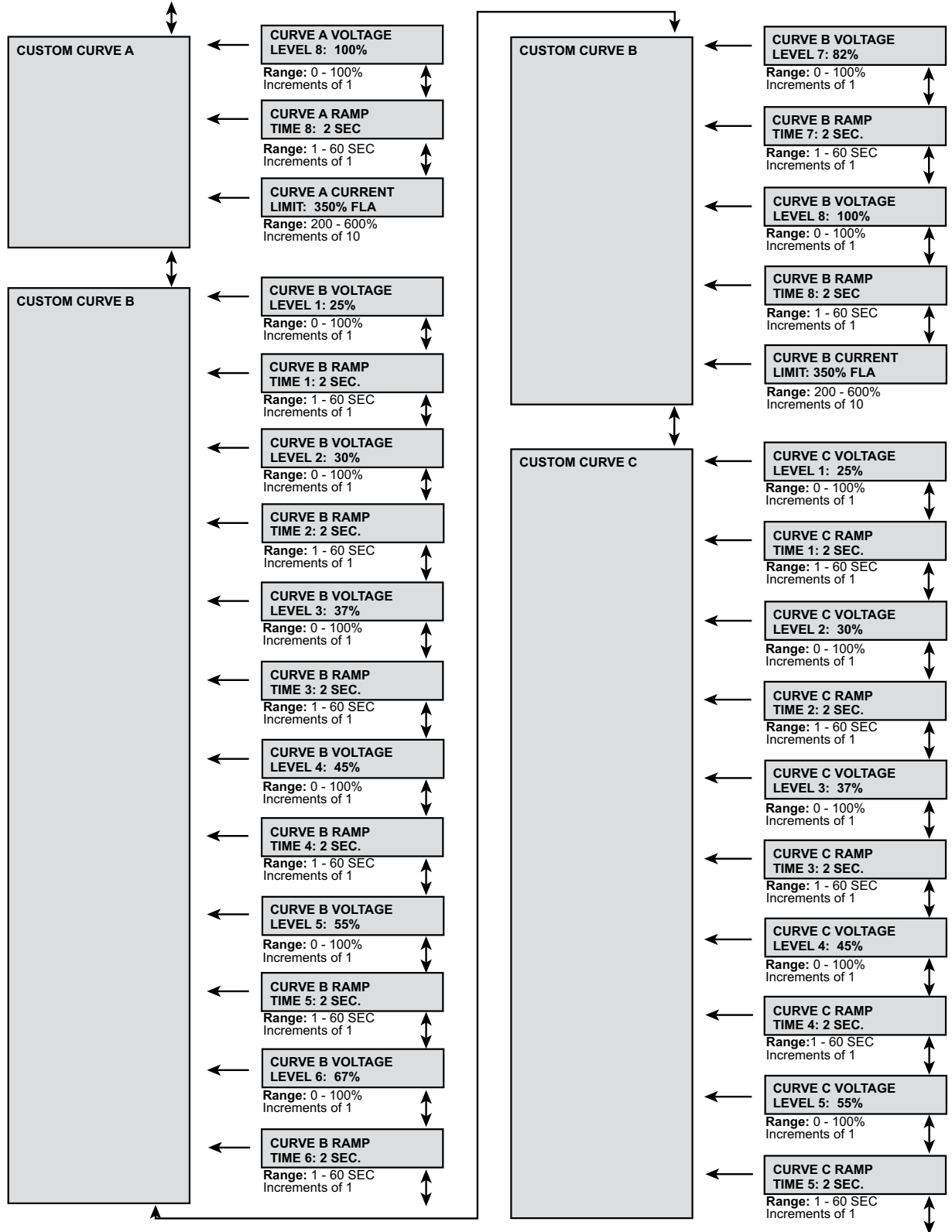

Chapter 5 - Setpoint Programming

SP.7 Custom Acceleration Curve (Setpoint Page 7) (Security Level: 3)

SP7.1 Setpoint Page 7 allows the user to custom design the acceleration curve (start curve) to the specific application. The user can custom design up to three different curves in the **SSM**. Only one curve can be active (enabled) at a time. Each of the three curves has eight voltage levels, with corresponding ramp times and a current limit setting.

Note: Each successive voltage level must be programmed to a voltage level equal to or greater than the previous level. All eight levels of voltages must be programmed and the eighth level has been preset at 100%.

- If Custom Accel Curve has been set to curve A, B or C on this page, the **SSM** will override the Start Control Mode selected in Setpoint Page 2, (even if Start Control Mode in Setpoint Page 2 has not been set to Custom Accel Curve).

Note: Setpoint Page 7 has a security level 3 requirement.

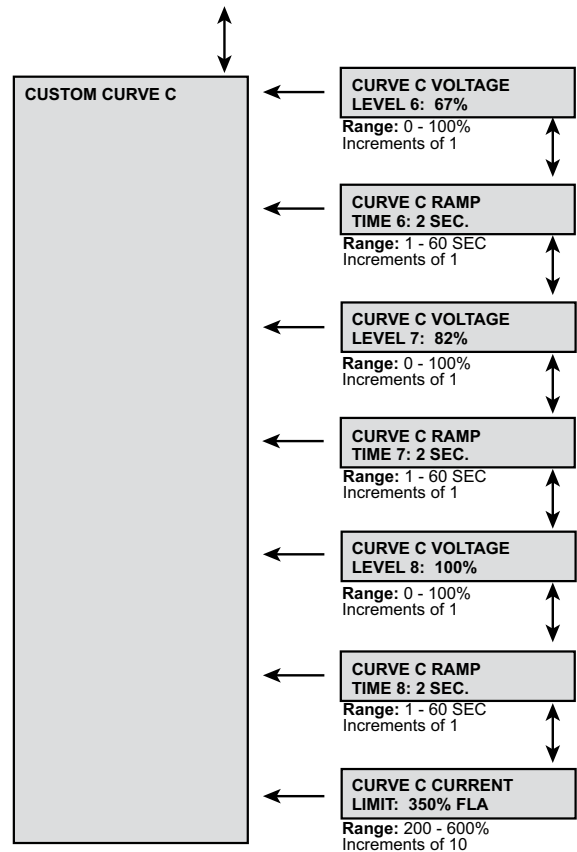

Chapter 5 - Setpoint Programming

SP.8 Overload Curve Configuration (Setpoint Page 8) (Security Level: 3)

Configures the unit's start and run protection mode. The unit has independent start and run curve protection and the settings can be based on the OL Class or set by the motor's locked rotor current and time.

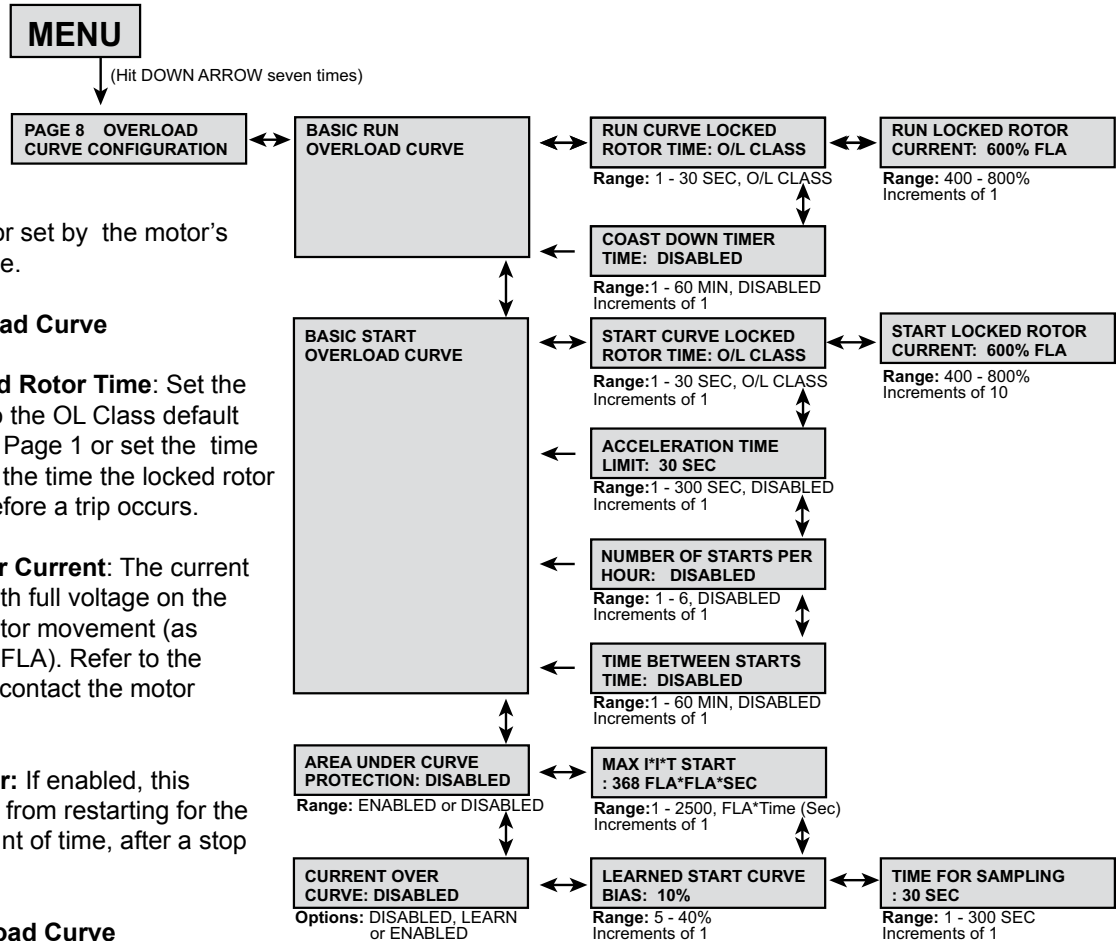

SP8.1 Basic Run Overload Curve

- **Run Curve Locked Rotor Time:** Set the locked rotor time to the OL Class default chosen in Setpoint Page 1 or set the time in seconds. This is the time the locked rotor condition exists before a trip occurs.
- **Run Locked Rotor Current:** The current the motor draws with full voltage on the windings and no rotor movement (as a percent of motor FLA). Refer to the nameplate data or contact the motor manufacturer.
- **Coast Down Timer:** If enabled, this prevents the motor from restarting for the programmed amount of time, after a stop command is given.

SP8.2 Basic Start Overload Curve

- **Start Curve Locked Rotor Time:** The locked rotor time can be set to the OL Class default chosen in Setpoint Page 1 or to a specific time. The overload condition must exist for the programmed amount of time before a trip occurs.
- **Start Locked Rotor Current:** The current the motor draws with full voltage on the windings and no motor movement (as a percent of motor FLA). Refer to the motor nameplate data or contact the motor manufacturer.
- **Acceleration Time Limit:** If the motor does not enter run mode (reach at speed) within the preset time, the unit trips on acceleration time limit.

- **Number of Starts per hour:** If enabled, this limits the maximum number of starts permitted per hour. This setpoint allows a maximum of 6 starts per hour. Contact motor manufacturer.
- **Time Between Starts:** If enabled, the **SSM** prevents another start attempt until the programmed time has expired.

Chapter 5 - Setpoint Programming

SP.9 RTD Option Configuration (Setpoint Page 9) (Security Level: 3)

Please note, this is supplied as an option.
Contact factory for more information.

Optional

Ranges:
 * 120 OHM NICKEL (NI)
 100 OHM NICKEL (NI)
 10 OHM COPPER (CU)
 100 OHM PLATINUM (PT)
 OFF
 ** OFF or 0 - 240C (32-464F) Example: ### C = ### F
 Increments of 1
 *** STATOR A1, STATOR A2, STATOR B1, STATOR B2, STATOR C1, STATOR C2,
 FRONT BEARING, BACK BEARING, BEARING BOX, AMBIENT, NONE

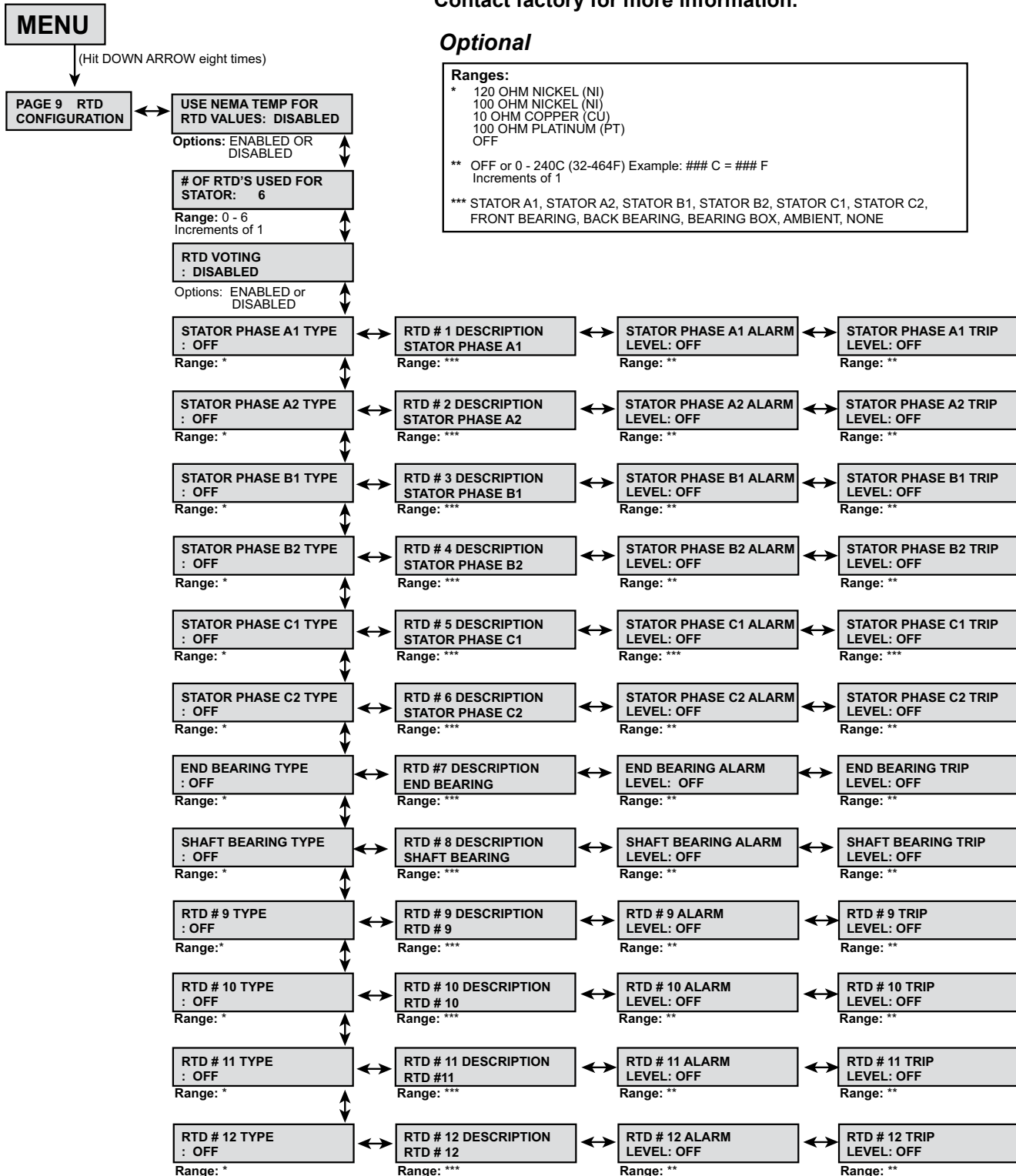

Chapter 5 - Setpoint Programming

SP.9 RTD Option Configuration (Setpoint Page 9) (Security Level: 3)

The **SSM** is available with an optional RTD card that provides 12 programmable RTDs which are individually programmable for type. The available types are 100 ohm platinum, 100 ohm nickel, 120 ohm nickel and 10 ohm copper. Each RTD can be identified with a description name of up to 15 characters (including spacing). Also, each individual RTD has its own alarm and trip level.

SP9.1 Use NEMA Temp for RTD Value: When this setpoint is enabled, the **SSM** will use the NEMA design insulation class to limit the maximum allowed range of the alarm and trip level. The maximum allowed temperature range is 240° C or (464°F).

SP9.2 # Of RTD'S Used for Stator: Up to six RTDs can be assigned to monitor the stator of the motor.

SP9.3 RTD Voting: When this is enabled, the **SSM** will not post a trip until 2 RTD's have exceeded the trip level. This prevents nuisance RTD tripping.

SP9.4 Each of the 12 RTDs is configured in the following manner. The first column is the RTD type, the second column is the RTD description, the third column is the alarm level, and the fourth column is the trip level. The first six RTDs have been pre-programmed with a description name for the STATOR, with two RTDs per phase. RTDs #1 & #2 have been named STATOR PHASE A1 and A2 respectively. RTDs #3&4 are named STATOR PHASE B1 and B2, RTDs #5&6 are named STATOR PHASE C1 and C2. If other description names are required, press the right arrow button from the RTD Type screen to go to the RTD description screen. If no alarm or trip level is required these setpoints can be turned off.

Chapter 5 - Setpoint Programming

SP.10 Set Password (Setpoint Page 10)

(Security Level: 3)

The **SSM** has three levels of user programmable setpoint screens. Level one setpoints do not require a password because the data contained in level one is basic nameplate data and starter control. Level two setpoint screens require a three-digit password to configure the protection schemes. Level three setpoint screens require a four-digit password to access the full range of protection and starter schemes.

SP10.1 Set Level 2 Password: This level uses a 3-digit password. The default level 2 password is 100.

SP10.2 Set Level 3 Password: Level three uses a 4-digit password. The default level 3 password is 1000.

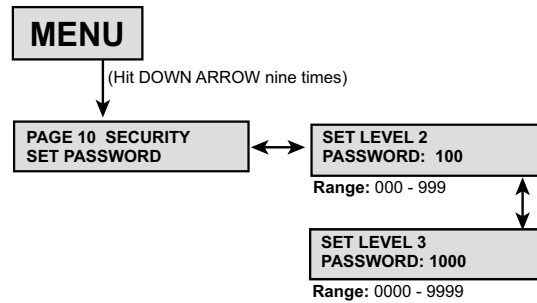

Chapter 5 - Setpoint Programming

SP.11 Communications (Setpoint Page 11)

(Security Level: 3)

SP11.1 Set Front Baud Rate: Configures the RS232 communications baud rate.

SP11.2 Set Modbus Baud Rate: Configures the modbus communications baud rate.

SP11.3 Modbus Address Number: Assigns a Modbus address to the *SSM* relay.

SP11.4 Set Access Code: Assigns an access code to the Modbus addressing. This is typically not used.

SP11.5 Set Link Baud Rate: Configures the RS422 communications baud rate between the keypad operator and the CPU board. (For applications with remote keypad only.)

SP11.6 Remote Start/Stop: Allows the RS485 Modbus communications to start and stop the motor. Contact factory for details.

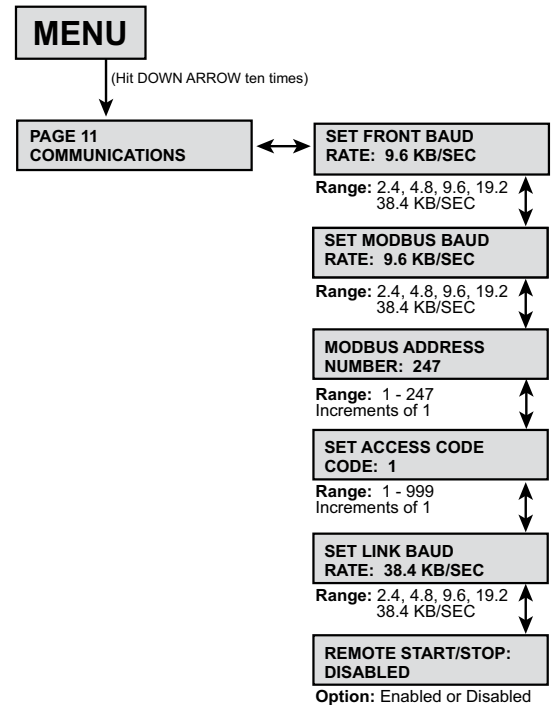

Chapter 5 - Setpoint Programming

SP.12 System Setpoints (Setpoint Page 12)

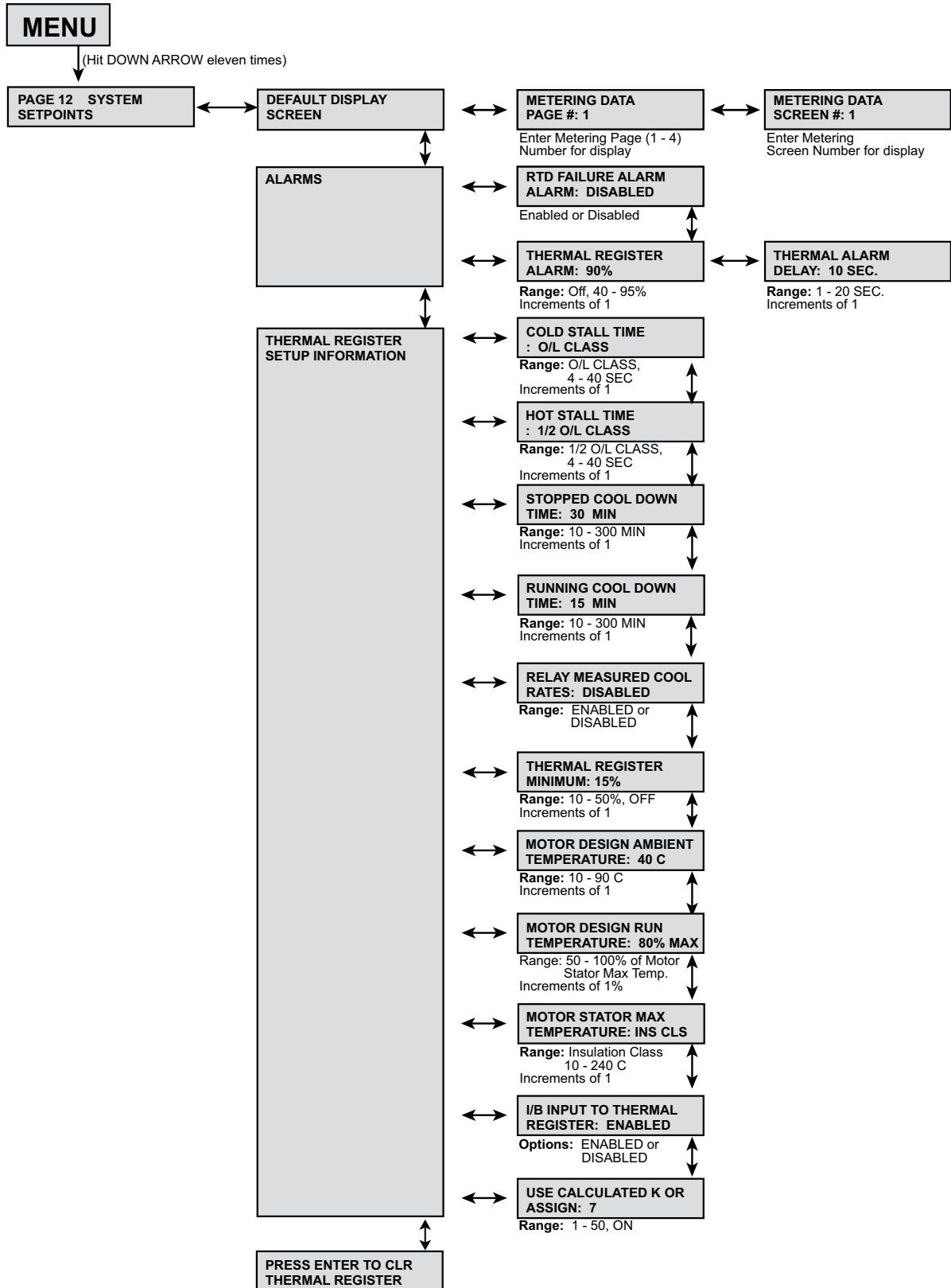

Chapter 5 - Setpoint Programming

SP.12 System Setpoints (Setpoint Page 12)

(Security Level: 3)

SP12.1 Default Display Screen: This setpoint group allows the user to choose the default screen the **SSM** displays while the motor is running. Select the metering page number (1-3), then select the metering screen number. The range varies depending on the selected page. To display a default screen, program the following two setpoints:

- **Metering Data Page#:** Range is Page 1 - 3.
- **Metering Data Screen#:** If Page 1 is selected as the default page, then Screens 1- 10 are available. If Page 2 Screens 1-29 are available. If Page 3 is selected then Screens 1-6 are available. (See Metering Menu, MP.1, for screen number assignment.)

SP12.2 Alarms: Configures the RTD failure alarm (when RTD option is included) and the thermal register alarm.

- **RTD Failure Alarm:** If enabled, and an RTD shorts or open, an alarm occurs. (Only if RTD option is installed).
- **Thermal Register Alarm:** Sets a level in the thermal register to generate an alarm when the Thermal Register Capacity Used has exceeded this level.
- **Thermal Alarm Delay:** The amount of time that the Thermal Register Used must exceed the setpoint before an alarm condition will occur.

SP12.3 Thermal Register Setup Information: This setpoint group will configure the thermal register and indicate to the **SSM** which inputs to use when thermal modeling.

- **Cold Stall Time:** Enter the time from the motor manufacturer's specification sheet or use the time defined by the OL Class. This setpoint is used to define the thermal capacity of the motor.
- **Hot Stall Time:** Enter the amount of time specified by the motor manufacturer or use half of the time defined by the OL Class.
- **Stopped Cool Down Time:** The time the motor requires to cool down after it has stopped. Use only the data provided by the motor manufacturer. This setpoint is used to configure the cooling rate of the thermal register.
- **Running Cool Down Time:** The amount of time the motor requires for cooling down while running. Use only the data provided by the motor manufacturer.

- **Relay Measured Cool Rates:** When the RTD option is supplied, the **SSM** can be configured to use the measured cool rates from the RTDs instead of the programmed settings. This setpoint should only be enabled when the RTD option is present.
- **Thermal Register Minimum:** Sets the value in the thermal register which represents a motor running at the nameplate current (with no overheating or negative sequence currents present).
- **Motor Design Ambient Temperature:** Use the data from the motor manufacturer's specifications. When RTD option is supplied, this setpoint will be the base point for the RTD biasing of the Thermal Register.
- **Motor Design Run Temperature:** Use the data from the motor manufacturer's specifications. This setpoint defines the operating temperature rise of the motor at full load amps or 100% load.
- **Motor Stator Max Temperature:** This represents the maximum temperature the stator insulation will withstand. The user may choose to use the temperature setting of the insulation class (selected in Setpoint Page 1) or enter a specific maximum temperature. This value should not exceed the stator's insulation temperature. This maximum temperature represents 100% thermal capacity.
- **U/B Input to Thermal Register:** When enabled it allows the **SSM** to use the line current imbalance information to bias the Thermal Register.
- **User Calculated K or Assign:** When the setpoint is set to ON the **SSM** will calculate the k constant factor for biasing the thermal register, or the user may choose to assign the k value.

SP12.4 Press Enter to CLR Thermal Register: Allows the level three password user to clear the thermal register for emergency restarts.

Chapter 5 - Setpoint Programming

SP.13 Calibration & Service (Setpoint Page 13) (Security Level: Factory Use Only)

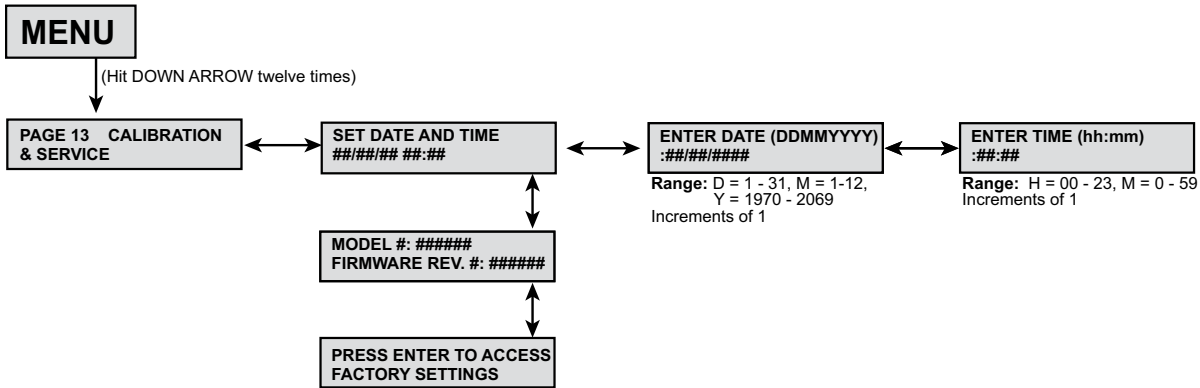

SP.13 Calibration & Service (Setpoint Page 13)

Certain screens are displayed for user information only, such as: Current date and time, Model number and Firmware revision number. Setpoint changes in this page will only be accessible to factory personnel.

SP13.1 Set Date and Time: Displays the date and time.

- **Enter Date (DDMMYYYY):** Allows the factory personnel to program the date for the **SSM** in the format shown.
- **Enter Time (HH:MM):** Allows the factory personnel to program the time for the **SSM**.

SP13.2 Model & Firmware #: Displays the model number and firmware revision in the **SSM**.

SP13.3 Press Enter to Access Factory Settings: Available to qualified personnel.

Chapter 6 - Metering Pages

The **SSM** offers performance metering which gives the user the ability to view information about the motor and the **SSM** unit.

6.1 Metering Page List

The following charts list each Metering Page and the functions within that page. The applicable section of the manual is also referenced.

6.1.1 Metering Menu & Data (Metering Page 1)

Metering Page	Description of Display	Screen
Page 1 Metering Menu & Data	Phase A, B, C and Ground Fault (Option)	1
	Average current of the % of imbalance and the motor's RPM	2
	Motor load as a percentage of motor FLA	3
	Line frequency and present phase sequence	4
	Percentage of remaining Thermal Register	5
	Thermal capacity required to start the motor	6
	Average time required to start	7
	Average current during start	8
	Measured I ² T required to start the motor	9
	Amount of time required to start the motor during the last successful start	10

6.1.2 Metering (Metering Page 2)

Metering Page	Description of Display	Screen
Page 2 Metering	Phase A, B, C currents and Power Factor	1
	Phase A, B, C currents and Ground Fault (Option)	2
	Displays kW and kVA	3
	Displays kVAR and Power Factor	4
	Displays Peak ON and kW Demand	5
	Displays Peak ON and kVA Demand	6
	Displays Peak ON and kVAR Demand	7
	Displays Peak ON and Amps Demand	8
	Clears Demand values	9
	Displays Megawatt hours used	10
	Press enter to clear statistics on MWH values	11

6.1.3 RTD Option Values (Metering Page 3)

Metering Page	Description of Display	Screen
Page 3 RTD Values	Hottest stator RTD (#1 - 6)	1
	Hottest non-stator RTD (#7 - 12)	2
	Temperature of start phase A1 in °C and °F	3
	Maximum temperature for RTD #1	4
	Same as Screens 3 - 4 for RTDs #2 - 12	5 - 26
	Clear the maximum temperature register (Level 3 password required)	27
	Measured running thermal stabilization time of motor (in minutes)	28
	Measured stopped cooling time (to ambient) of motor (in minutes)	29

6.1.4 Status (Metering Page 4)

Metering Page	Description of Display	Screen
Page 4 Status	Current status	1
	Amount of time remaining before an overload trip occurs	2
	Amount of time remaining from a thermal inhibit signal	3
	Coast down time remaining	4
	Amount of time remaining before a start command can be given	5
	Excessive number of starts per hour	6

Chapter 6 - Metering Pages

6.1.5 Event Recorder (Metering Page 5)

6.1.6 Last Trip

(Metering Page 6)

6.1.7 Statistics

(Metering Page 7)

Metering Page	Description of Display	Screen
Page 5 Event Recorder	Displays the event with date and time (Up to 60 events)	1
	Displays Phase A, B, C current values, Ground Fault (Option) at time of trip	1A
	Displays Vab, Vbc, Vca and Power Factor at time of trip	1B

Metering Page	Description of Display	Screen
Page 6 Last Trip	Cause of last trip	1
	Measured phase current	2
	Measured voltage and power factor	3
	Imbalance percentage, the frequency and the kW	4
	Hottest stator RTD temperature	5
	Hottest non-stator RTD temperature	6

Metering Page	Description of Display	Screen
Page 7 Statistics	Accumulated total running hours	1
	Clear the total running hour count	2
	Total number of trips	3
	Number of start and run overload trips since the last statistical data clearing	4
	Number of frequency trips and imbalance trips	5
	Overcurrent trips	6
	Stator and non-stator RTD trips	7
	Ground fault hiset and loset trips	8
	Acceleration time trips	9
	Start under curve trips	10
	Start over curve trips	11
	I ² T start curve trips	12
	Learned start curve trips	13
	Fail shunt trip trips	14
	Phase loss trip trips	15
	Tach accel trip trips	16
	Undervoltage and Overvoltage trips	17
	Power Factor trips	18
	Phase reversal trips	19
	Exp Inp #1	20
	Exp Inp #2	21
	Exp Inp #3	22
	Exp Inp #4	23
	Press enter to clear statistics	24

Chapter 6 - Metering Pages

6.2 Metering Menu

Push MENU key to toggle the screens between Setpoint Menu and Metering Menu and follow the arrow keys to get to different screens.

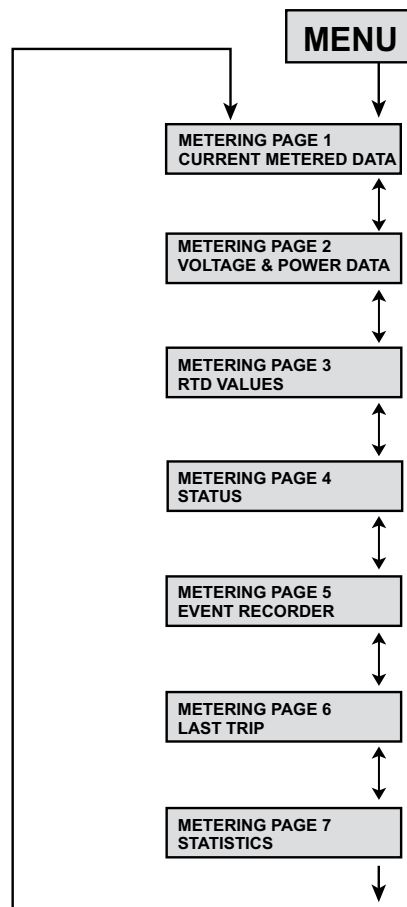

Chapter 6 - Metering Pages

MP.1 Metering Data (Metering Page 1)

Displays the basic current metering data:

- Screen 1:** Phase A, B, C and ground fault (option) current.
- Screen 2:** Displays the average current, the percent of imbalance and the motor's RPM (available with tachometer input)
- Screen 3:** Displays the motor load in percent of motor FLA.
- Screen 4:** Displays the line frequency and the present Phase Order.
- Screen 5:** Displays the percent of the remaining thermal register. In order for the motor to successfully start, the percentage must be greater than the thermal capacity required for a successful start.
- Screen 6:** Displays the thermal capacity required to successfully start the motor.
- Screen 7:** Displays the average time required to start.
- Screen 8:** Displays the average current during start.
- Screen 9:** Displays the measured I²T required to start the motor.
- Screen 10:** Displays the amount of time required to start the motor during the last successful start.

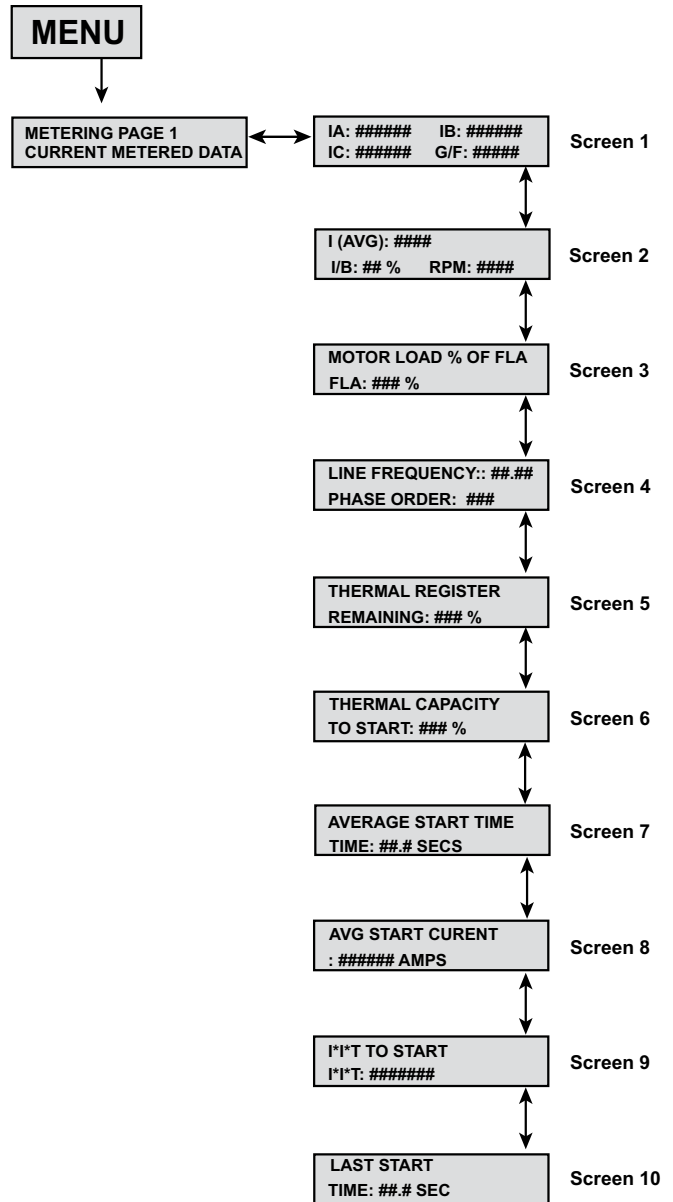

Chapter 6 - Metering Pages

MP.2 Metering (Metering Page 2)

Displays the **SSM** statistical voltage metering information.

- Screen 1:** Displays Phase A, B, C and Power Factor.
Note: P/F: N/A Motor stopped
P/F: LG #.## (Lagging)
P/F: LD #.## (Leading)
- Screen 2:** Displays Phase A, B, C and Ground Fault Current.
- Screen 3:** Displays kW and kVA.
- Screen 4:** Displays kVAR and Power Factor.
- Screen 5:** Displays Peak On and kW demand.
- Screen 6:** Displays Peak On and kVA demand.
- Screen 7:** Displays Peak On and kVAR demand.
Note: P/F: N/A Motor stopped
P/F: LG #.## (Lagging)
P/F: LD #.## (Leading)
- Screen 8:** Displays Peak On and Amps demand.
- Screen 9:** Clears Demand Values.
- Screen 10:** Displays the Megawatthours used.
- Screen 11:** Press Enter to clear statistics on MWH values.

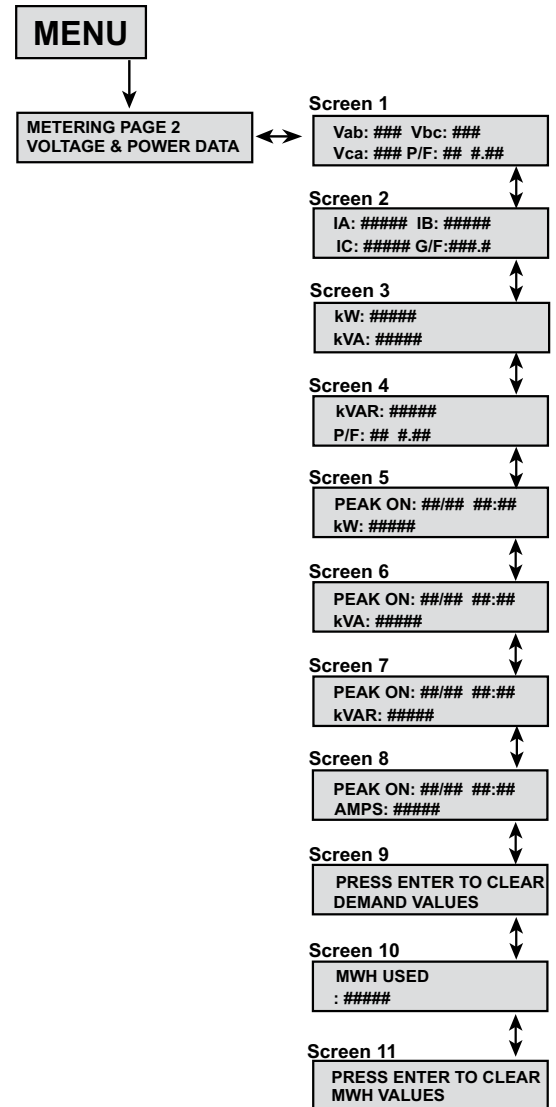

Chapter 6 - Metering Pages

MP.3 RTD Values (Metering Page 3)

Displays the RTD information (when RTD option is supplied)

- Screen 1:** Displays the hottest stator RTD (#1 - 6 depending upon number of RTDs used for stator).
- Screen 2:** Displays the hottest non-stator RTD (#7-12 if #1-6 is used for stator).
- Screen 3:** Displays the temperature of stator phase A1 in °C and °F.
- Screen 4:** Displays the maximum temperature for RTD #1 since the last command to clear the thermal register.
- Screen 5 - 26:** Same as Screens 3 - 4 for RTDs # 2 - 12.
- Screen 27:** Allows the user to clear the maximum temperature register upon entering the setpoint level 3 password.
- Screen 28:** Displays the measured run cool time in minutes.
- Screen 29:** Displays the measured stopped cool time in minutes.

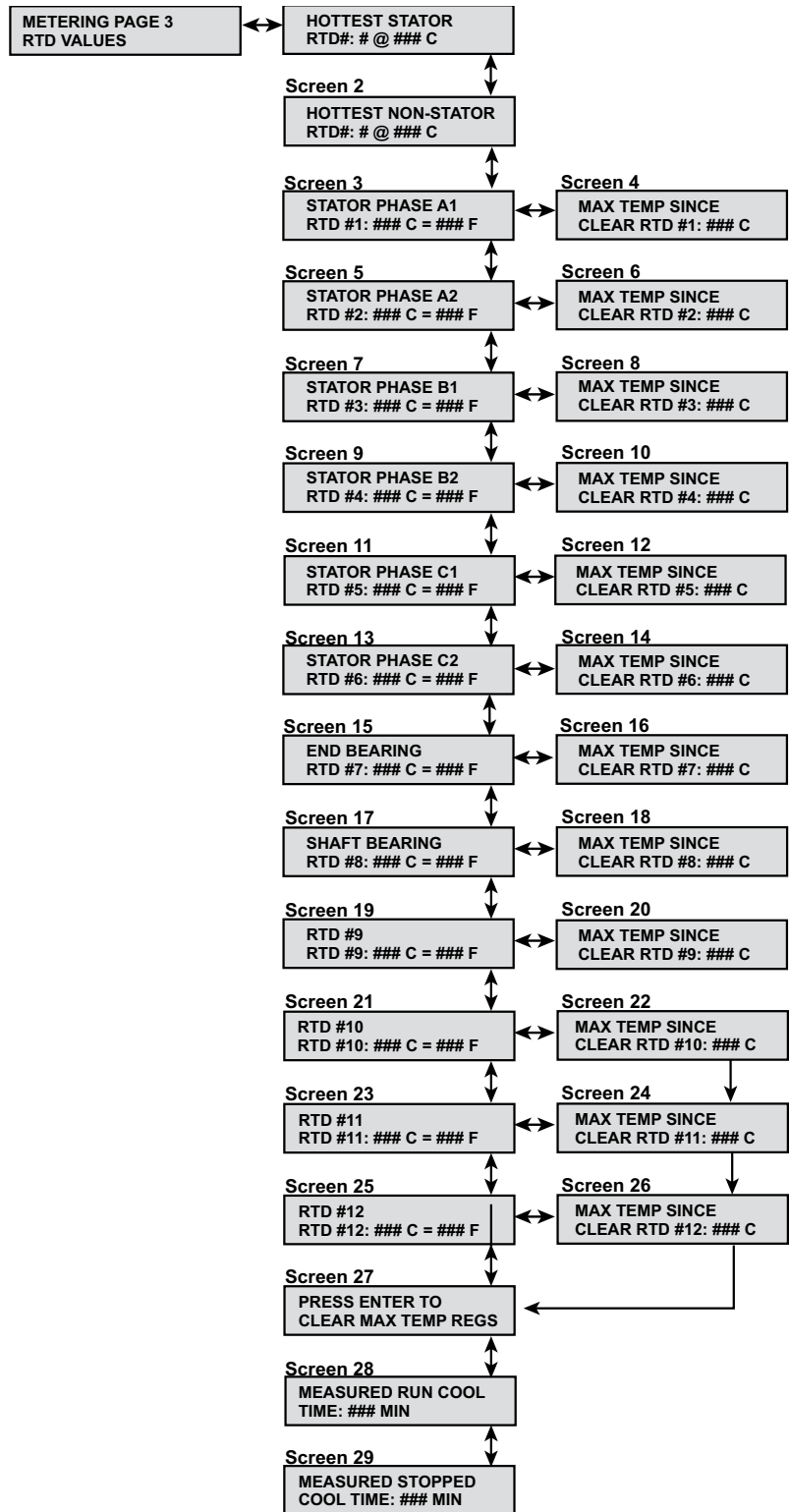

Chapter 6 - Metering Pages

MP.4 Status (Metering Page 4)

Displays the present status of the **SSM** soft start.

Screen 1: Displays the present state of the unit as follows:

Screen 1 Note:

CURRENT STATUS Screens include:

1. **MOTOR STOPPED
READY TO START**
2. **MOTOR STARTING
MULT. OF FLA**
3. **MOTOR RUNNING
AT ###.## X FLA**
4. **LAST TRIP CAUSE
NONE (or trip cause)**
5. **PROGRAMMING
SETPOINTS**
6. **MOTOR STATUS
UNKNOWN STATE ###** (displays relay state upon error)

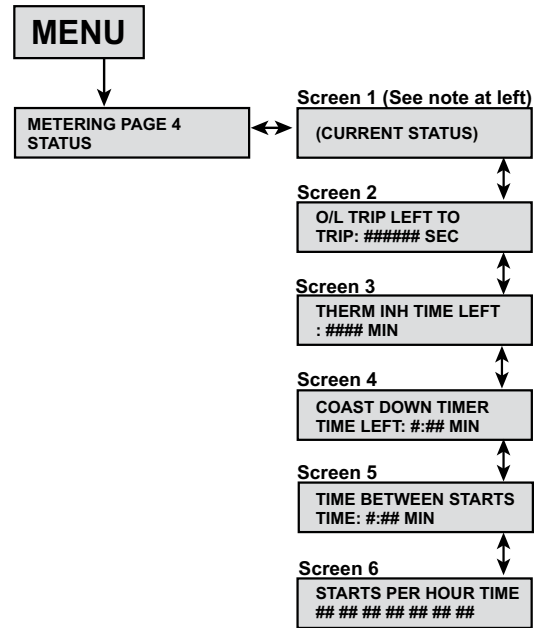

Screen 2: Displays the amount of time remaining before an overload trip will occur.

Screen 3: Displays the amount of time remaining from a thermal inhibit. The inhibit time comes from the amount of thermal register remaining versus the amount of thermal capacity required to start.

Screen 4: Displays the coast down time remaining (Backspin time). The time remaining depends upon the user setting in Setpoint Page 8, Coast Down Time.

Screen 5: Displays the amount of time remaining before a start command can be given.

Screen 6: If the number of starts per hour has exceeded the setting.

Chapter 6 - Metering Pages

MP.5 Event Recorder - 60 Events (Metering Page 5)

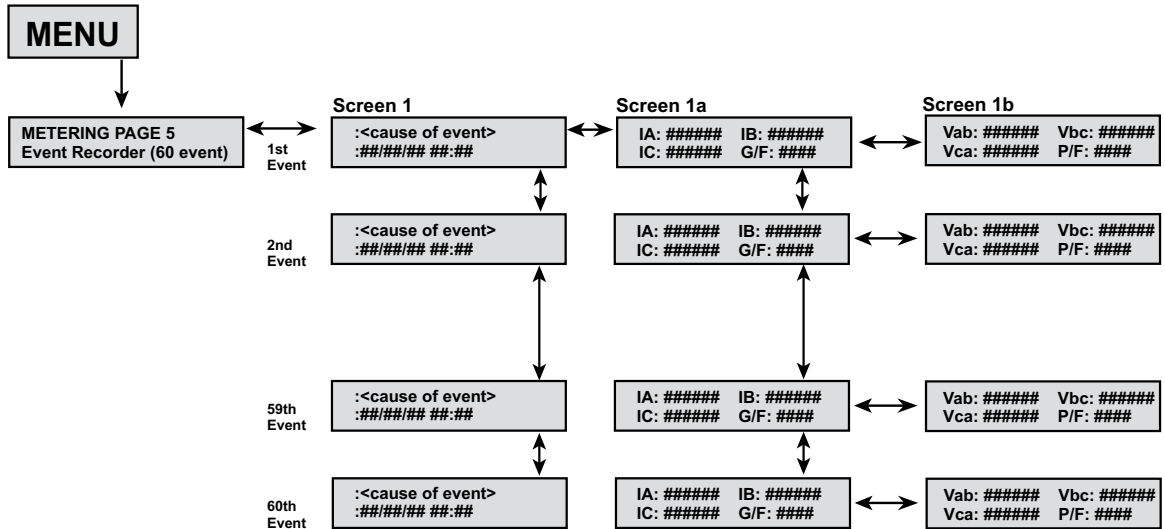

All events will be viewed from oldest event in buffer to most recent event.

The events are listed from oldest to most recent.

Screen 1: Displays the event (i.e., Imbalance Trip) with the date and time it occurred.

Screen 1a: Displays the current at Phase A, B, C and the ground fault at the time of the trip.

Screen 1b: Displays the Vab, Vbc, Vca and power factor at the time of trip.

Chapter 6 - Metering Pages

MP.6 Last Trip (Metering Page 6)

Displays the information regarding the last trip.

Screen 1: Displays the cause of the last trip.

Screen 2: Displays the measured phase current at the time of the trip.

Screen 3: Displays the Vab, Vbc, Vca and power factor at the time of trip.

Screen 4: Displays the imbalance percentage, the frequency and the kW at the time of the trip.

Screen 5: Displays the hottest stator RTD temperature (when RTD option present) at time of the trip.

Screen 6: Displays the hottest non-stator RTD temperature (when RTD option present) at the time of the trip.

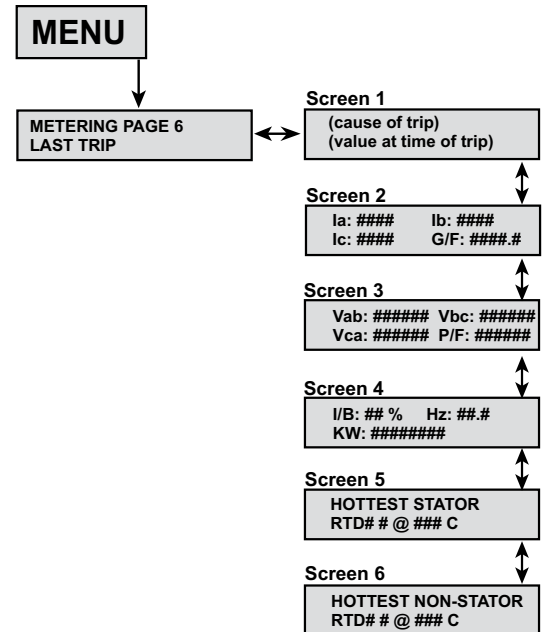

Chapter 6 - Metering Pages

MP.7 Statistics (Metering Page 7)

Displays the **SSM** statistical trip information.

Screen 1: Displays the total of megawatt hours.

Screen 2: Displays the accumulated total running hours.

Screen 3: Clears the total running hour count.

Screen 4: Displays the total number of trips : last clearing of the statistical data number of short circuit trips.

Screen 5: Displays the number of start over/ overload trips since the last clearing of statistical data.

Screen 6: Displays the number of frequency imbalance trips.

Screen 7: Displays the number of overcurrent

Screen 8: Displays the number of Stator and RTD Trips

Screen 9: Displays the number of Ground Fault Lo Set trips

Screen 10: Displays the number of acceleration

Screen 11: Displays the number of start under

Screen 12: Displays the number start over curve

Screen 13: Displays the number of I²T start curve

Screen 14: Displays the number of learned start curve trips.

Screen 15: Displays the number of fail shunt trip

Screen 16: Displays the number of phase loss

Screen 17: Displays the number of tachometer acceleration trips.

Screen 18: Displays the number of undervoltage/ overvoltage trips.

Screen 19: Displays the number of power factor

Screen 20: Displays the number of phase reversal

Screen 21: Displays the number of external input

Screen 22: Displays the number of external input

Screen 23: Displays the number of external input

Screen 24: Displays the number of external input

Screen 25: Requires a Security Level 2 password to clear the statistics.

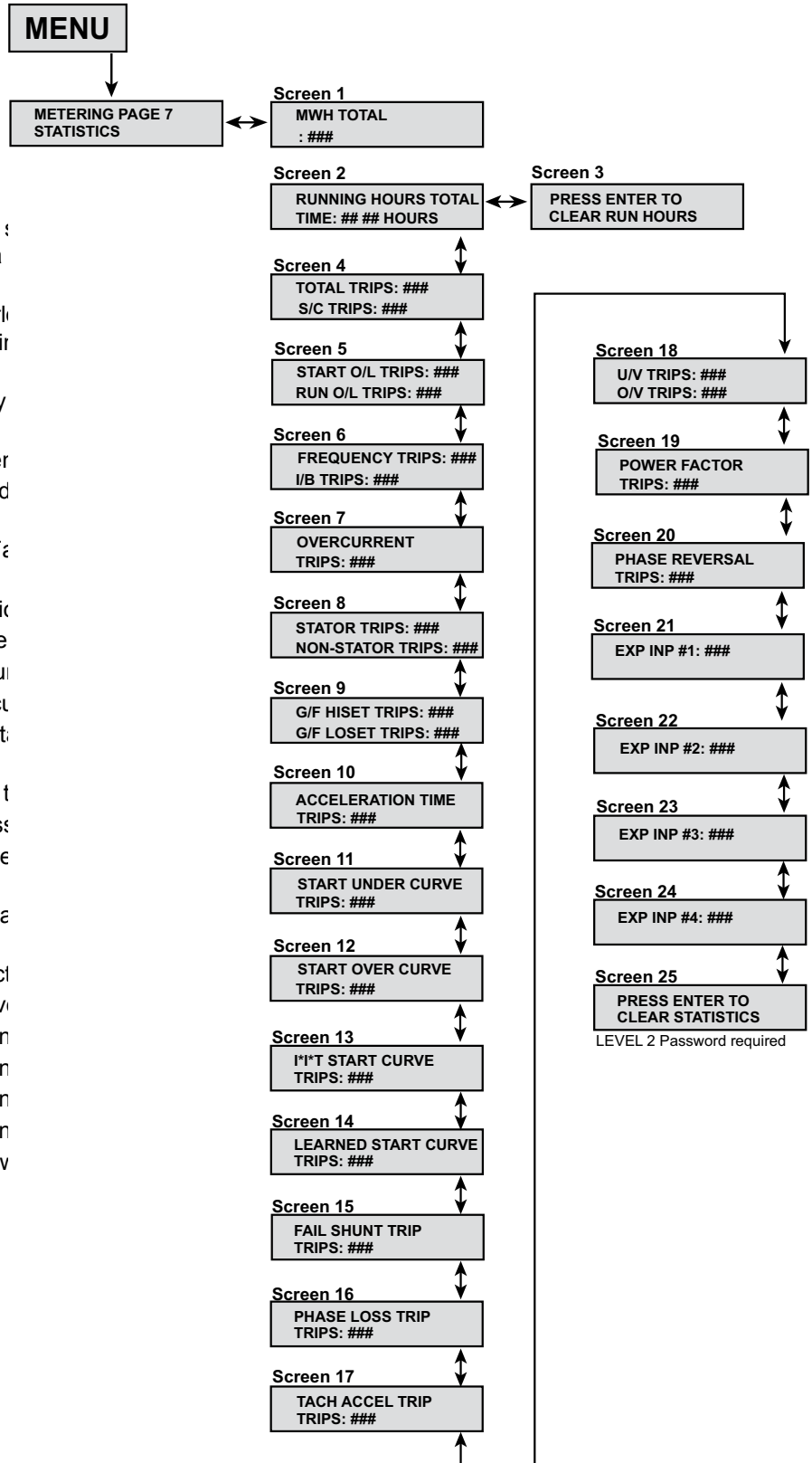

Chapter 7 - Maintenance and Troubleshooting

The **SSM** is designed to be a maintenance-free product. However, as with all electronic equipment, the unit should be checked periodically for dirt, moisture or industrial contaminants. These can cause high voltage arc-over, carbon tracking or prevent proper cooling of the SCR heat sinks. All bolts should be checked annually for proper tightness using an accurate torque wrench. According to the manufacturer's manual, check the contactor for air gap spacing of the vacuum bottles.

Note: If the unit is installed in a contaminated environment and forced air cooling is used, blower filters must be checked and cleaned regularly to insure proper air flow and cooling of the enclosure.

7.1 - Failure Analysis

When a fault occurs, the LCD will display the fault error while the listed LED and AUX Relay will be lit. Please clear all faults before attempting to restart the unit. Note: If the problem persists after the required programming changes have been made, and all corrective action has been taken, please contact the factory for assistance.

Problem	CPU LCD Display	LED	Aux Relay	Possible Cause	Solutions
<i>One of the main fuses blows or circuit breaker opens when the power is applied or disconnect is open</i>	TCB FAULT TRIP	Trip	AUX1	Short circuit between the inputs	Locate and remove short
				Faulty SCRs	Remove power and test SCR(s). Refer to Section 7.1.1 for the SCR testing procedure
<i>Short Circuit Trip</i>	SHORT CIRCUIT TRIP	Trip	AUX1	Short circuit or ground fault in motor/cabling	Locate and remove short or ground
				Phase Loss	Repair cause of phase loss
				Branch circuit protection not correctly sized	Verify correct sizing of branch circuit protection
				Faulty main circuit board	Remove power and replace main circuit board.
<i>Single Phase Trip</i>	SINGLE PHASE TRIP (Check LCD display for possible fault indicators)	Trip	AUX1	Single phase incoming power	Correct problem with incoming power
				Faulty SCRs	Remove power and test SCR(s). Refer to Section 7.1.1 for the SCR testing procedure
<i>Thermostat trips during run</i>	EXTERNAL TRIP ON THERMOSTAT	Trip	AUX1	Fan(s) not functioning (if supplied)	If fans have power, remove power and replace fan(s). If fans do not have power, find cause of power loss and repair.
				Heatsink coated with dirt	Remove power and clean heatsink with high pressure air (80 - 100 psi max clean and dry air)
				Overcurrent on unit	Verify that running current does not exceed unit rating
				Environment temperature over 122° F (ambient temperature for chassis units) or over 104°F (ambient temperature for enclosed version)	Place unit in environment temperature less than 122°F for panel version or less than 104°F for enclosed version.
				Bypass failed to close	Check bypass contactor and wiring

Chapter 7 - Maintenance and Troubleshooting

Problem	CPU LCD Display	LED	Aux Relay	Possible Cause	Solutions
Phase Loss	PHASE LOSS	Trip	AUX1	Loss of 1 or more phases of power from utility or generated power	Check power source
				Blown power fuses	Check for short circuits
Overload	OVERLOAD TRIP	Trip	AUX1	Improper programming	Check motor nameplate versus programmed parameters
				Possible load damage or jammed load	Check motor currents
Stall prevention	ACCEL TIME TRIP	Trip	AUX1	Improper setting for motor load condition	Verify current limit setting
				Damaged load	Check for load failure
Under Voltage Trip	UNDER VOLTAGE TRIP	Trip	AUX1	Improper programming	Check setpoint settings
				Wrong position of disconnected breaker	Check disconnect or open breaker
				Main contactor failed to close	Check internal connections
				Transformer too small	Reduce current limit setting, saturation or sagging power supply transformer
Under Current Trip	UNDER CURRENT TRIP	Trip	AUX1	Improper programming	Check setpoint settings
				Unloaded motor	Check load
Self-test Failure	SELF-TEST FAILURE	Trip	AUX1	Failed CPU or Main Firing Board	Contact factory
				Vibration	Check internal wiring connections
Line Frequency Trip	OVER OR UNDER FREQUENCY TRIP	Trip	AUX1	Generator Power Problem or grid change	Troubleshoot and repair generator
					Contact utilities company
					Main board failure
					Three phase power removed from Main Board
Any Ground Fault Trip	GROUND FAULT HI-SET OR LO-SET	Trip	AUX1	Improper programming	Check program setpoints
				Any wire going to ground (i.e. stator ground, motor ground, soft start ground)	Check with meggar or Hi-pot motor leads and motor
				High vibration or loose connections	Check internal connections
Motor stopped during run	Check for fault indication	Trip	AUX1	Warning: This is a serious fault condition. Ensure that the fault condition is cleared on the load before attempting to restart the motor.	
				Load shorted/ grounded/ faulted	Remove power and repair.
				Faulty main circuit board	Replace the main circuit board
Control circuit fuses blow after control power is applied.	None	None	None	Short in control circuit	Remove power, locate and remove this short
				Wrong control voltage	Apply the correct voltage to the control circuit

Chapter 7 - Maintenance and Troubleshooting

Problem	CPU LCD Display	LED	Aux Relay	Possible Cause	Solutions
<i>Motor will not start</i>	Any fault indication message	Trip	AUX1	No control voltage applied to control board	Apply control voltage to TB1 pins 1 and 6 on the power board
				Control power transformer failure or CPT fuse failure	Remove power and replace the power transformer or the CPT fuse
				Start circuit wired incorrectly	Remove power and correct the start circuit wiring
				No start command	Apply the start command
				No 3 phase line voltage	Apply 3 phase line voltage to the unit
				Shorted SCR in starter	Remove power and test SCR(s). Refer to Section 7.1.1 for the SCR testing procedure
				Faulty control logic	Remove power and repair the control logic.
				Failure of main circuit board	Replace the main circuit board
<i>Motor vibrates/ Motor growls while starting or extremely unbalanced motor currents run mode</i>	IMBALANCE TRIP IMBALANCE ALARM	Trip	AUX1	Faulty motor	Check the motor and the motor connections
				Faulty SCRs	Remove power and perform the SCR device checks
				Faulty gate/cathode on SCRs	Remove power and test SCR(s). Refer to Section 7.1.1 for the SCR testing procedure
				Faulty main circuit board	Replace the main circuit board
		Alarm	AUX2	Faulty motor/wiring	Troubleshoot and repair/replace wiring
				Faulty main circuit board	Replace the main circuit board

7.1.1 - SCR Testing Procedure

Perform the SCR Heat Sink Ohm test on each Stack Assembly.

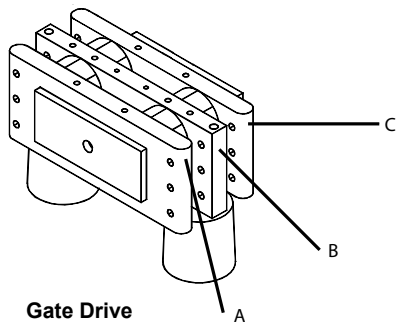

Gate Drive Board

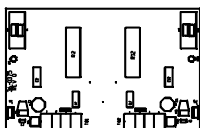

K G G K
WHITE WIRES
K=CATHODE
G=GATE

Test	Ohm Meter Reading	Result
From Position A to Position B	Greater than 10K Ohm	Pass
	Less than 10K Ohm	Fail
From Position B to Position C	Greater than 10K Ohm	Pass
	Less than 10K Ohm	Fail
Gate to Cathode for each SCR	8 to 100 Ohms	Pass (Typical 8 to 20 Ohms)
	Less than 10 or greater than 100 Ohms	Fail

Note: Allow 15 minutes after shutdown for DV/DT network to discharge DC voltage.

Chapter 7 - Maintenance and Troubleshooting

7.2 - Typical Block Diagram

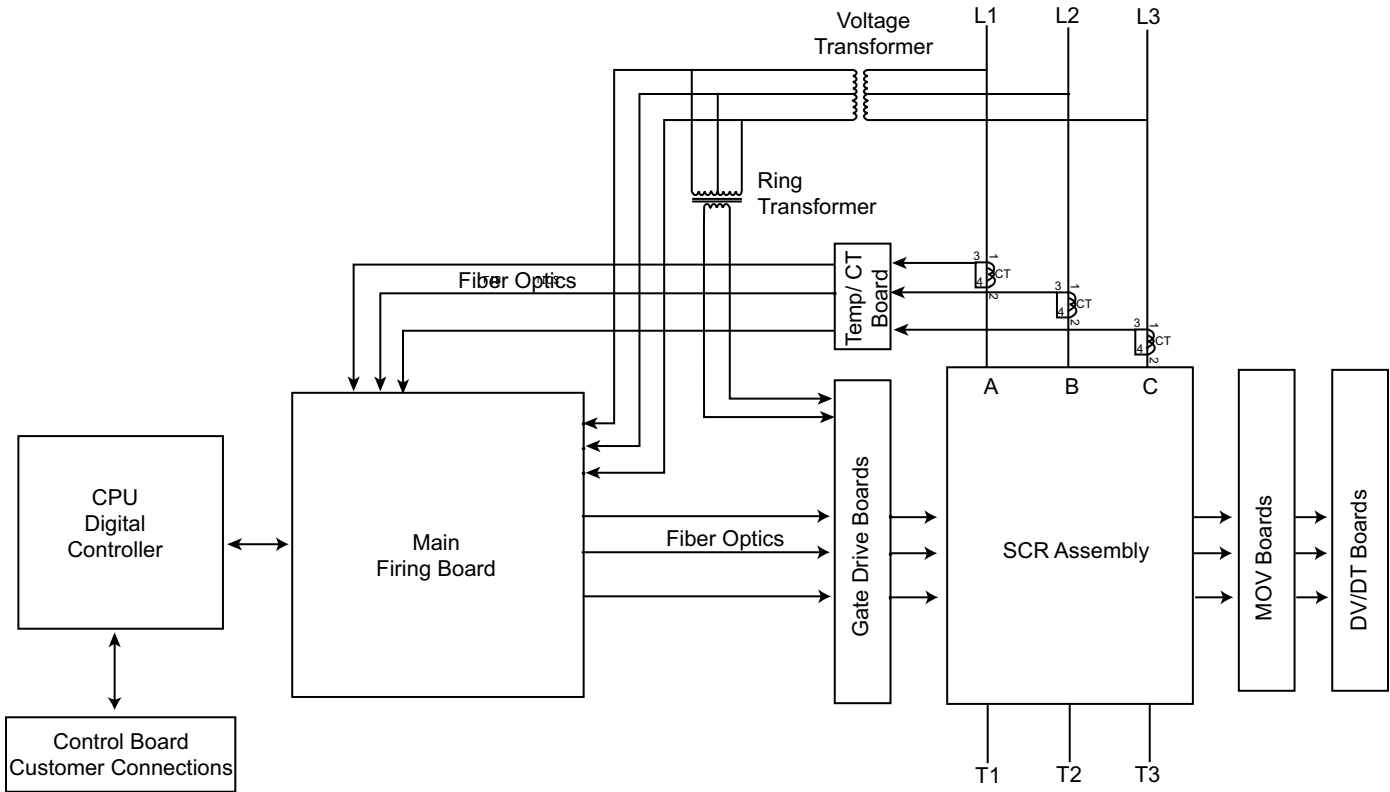

Chapter 7 - Maintenance and Troubleshooting

7.3 - Overload Curve Definition

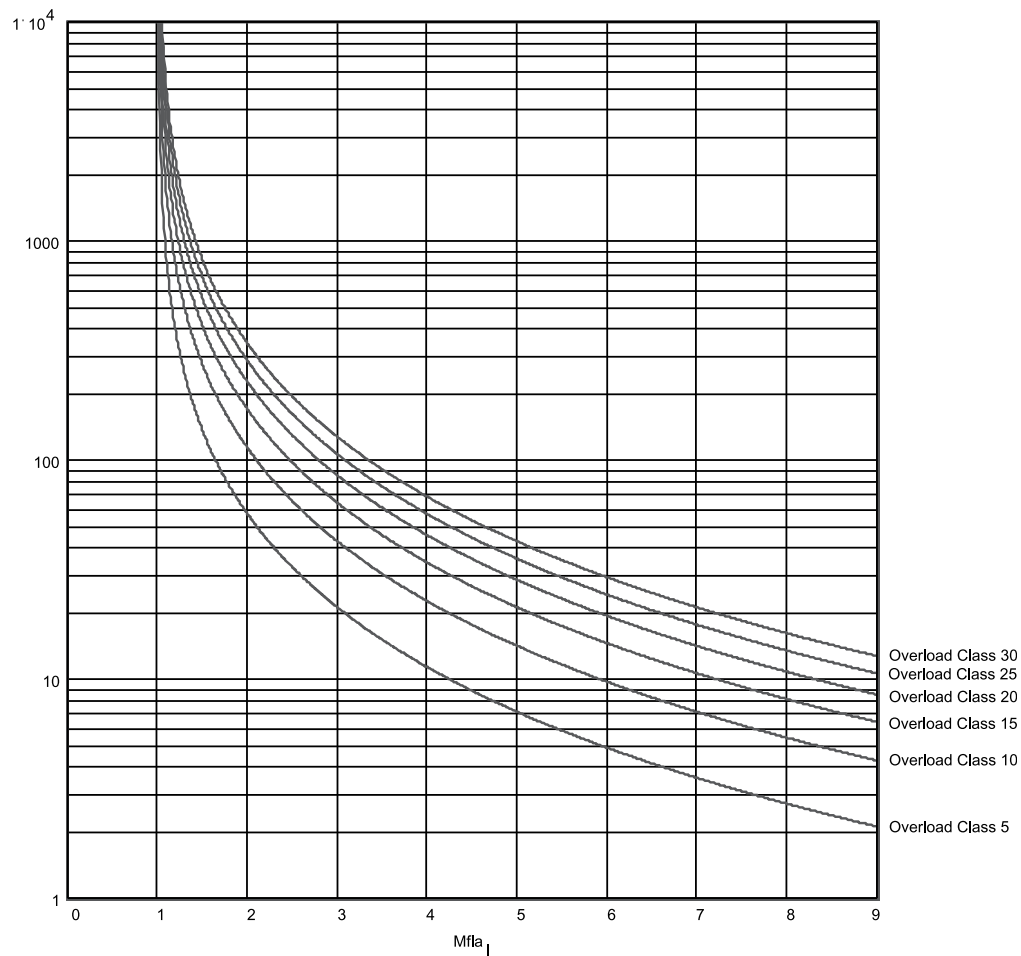

Chapter 7 - Maintenance and Troubleshooting

7.4 - TCB D

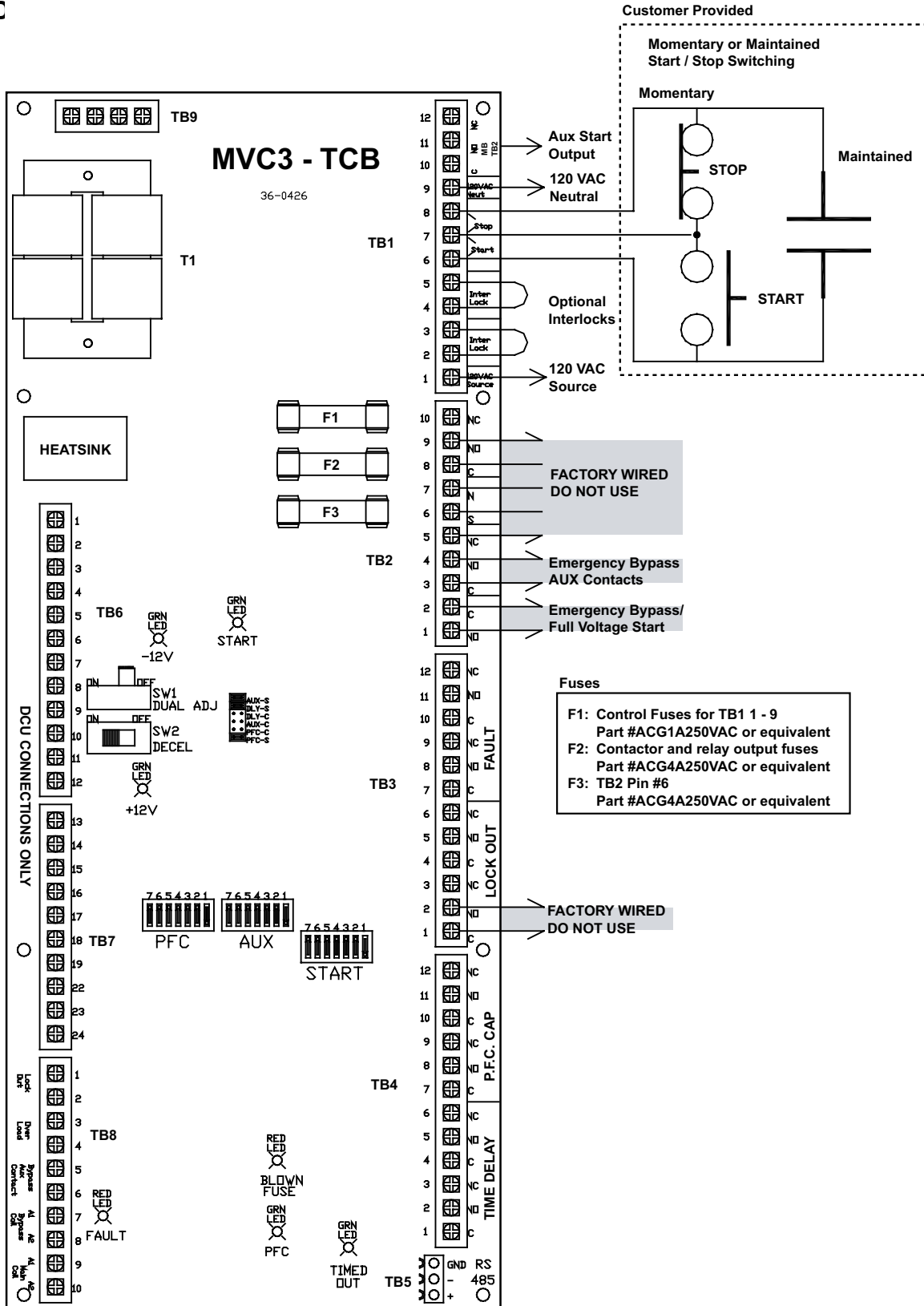

Chapter 7 - Maintenance and Troubleshooting

7.5 - Typical Medium Voltage Soft Starter

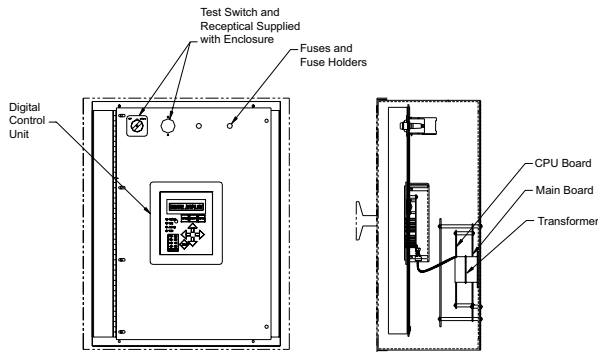
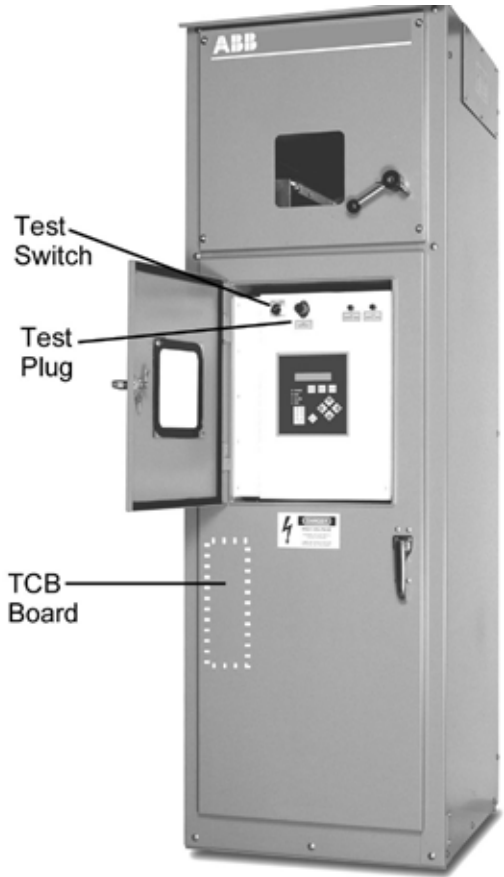
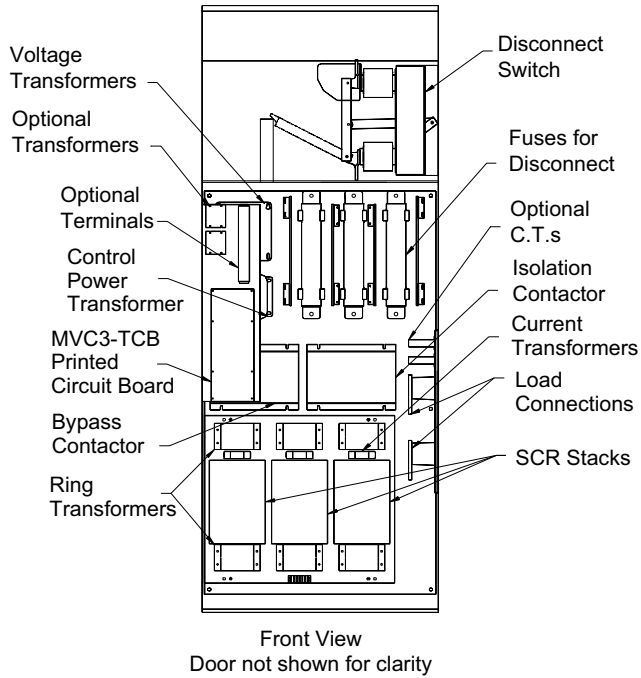

PCB Mounting Order

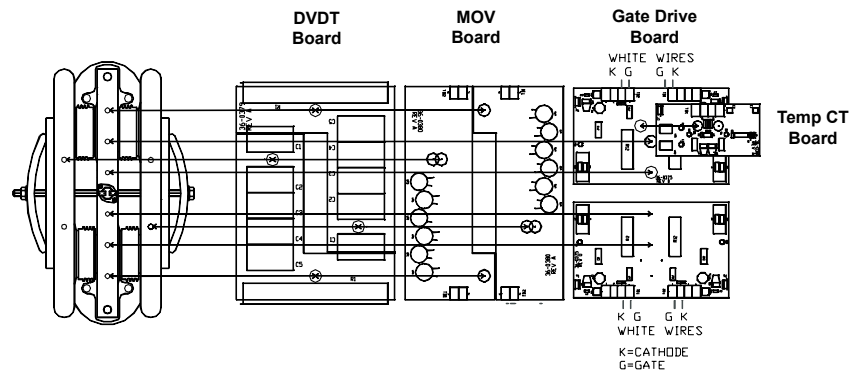

Chapter 7 - Maintenance and Troubleshooting

7.6 - Typical Wiring & Interconnect Diagram for Soft Starter with Line Start Section (Models Rated 2300 - 7200V)

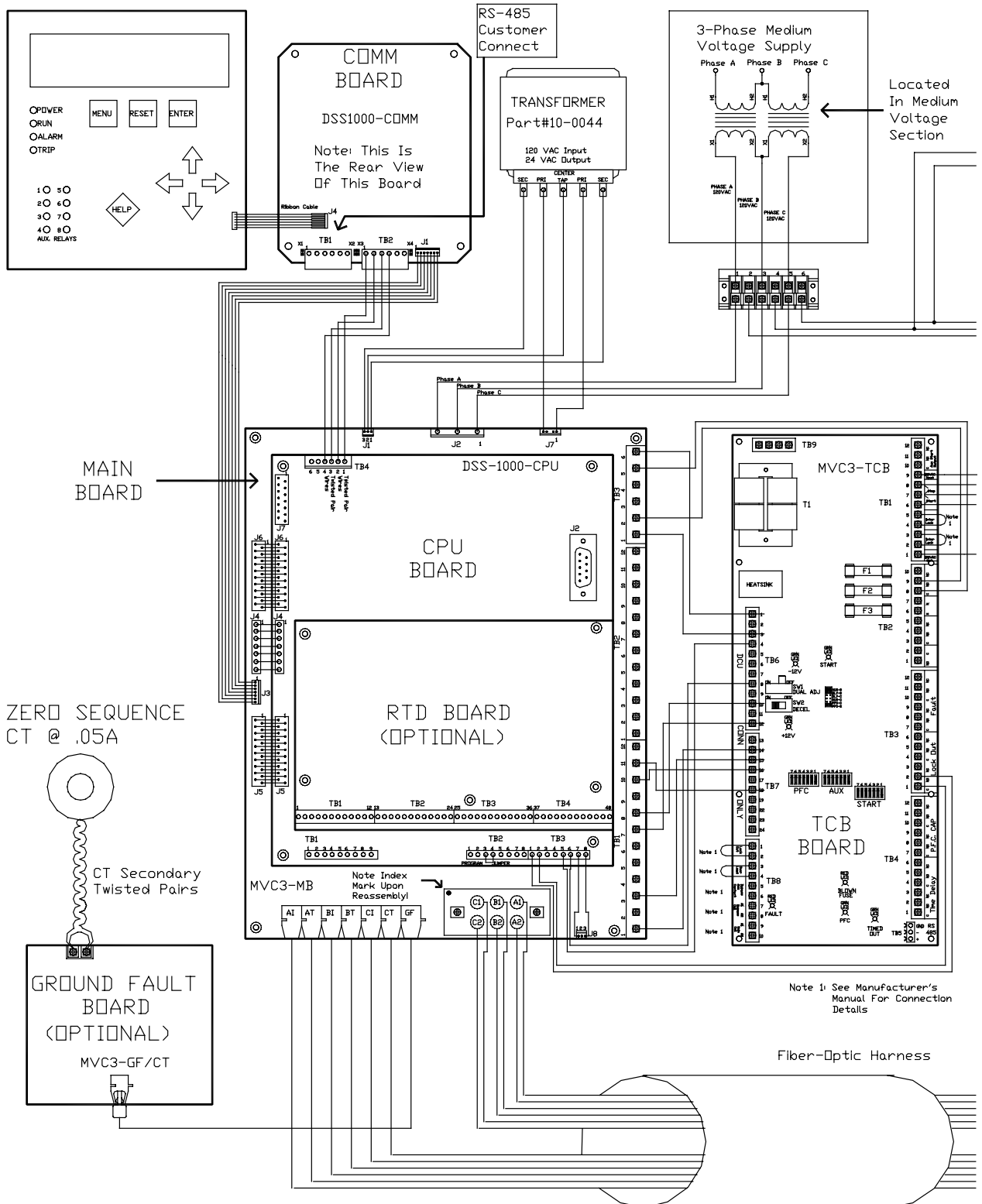

Chapter 7 - Maintenance and Troubleshooting

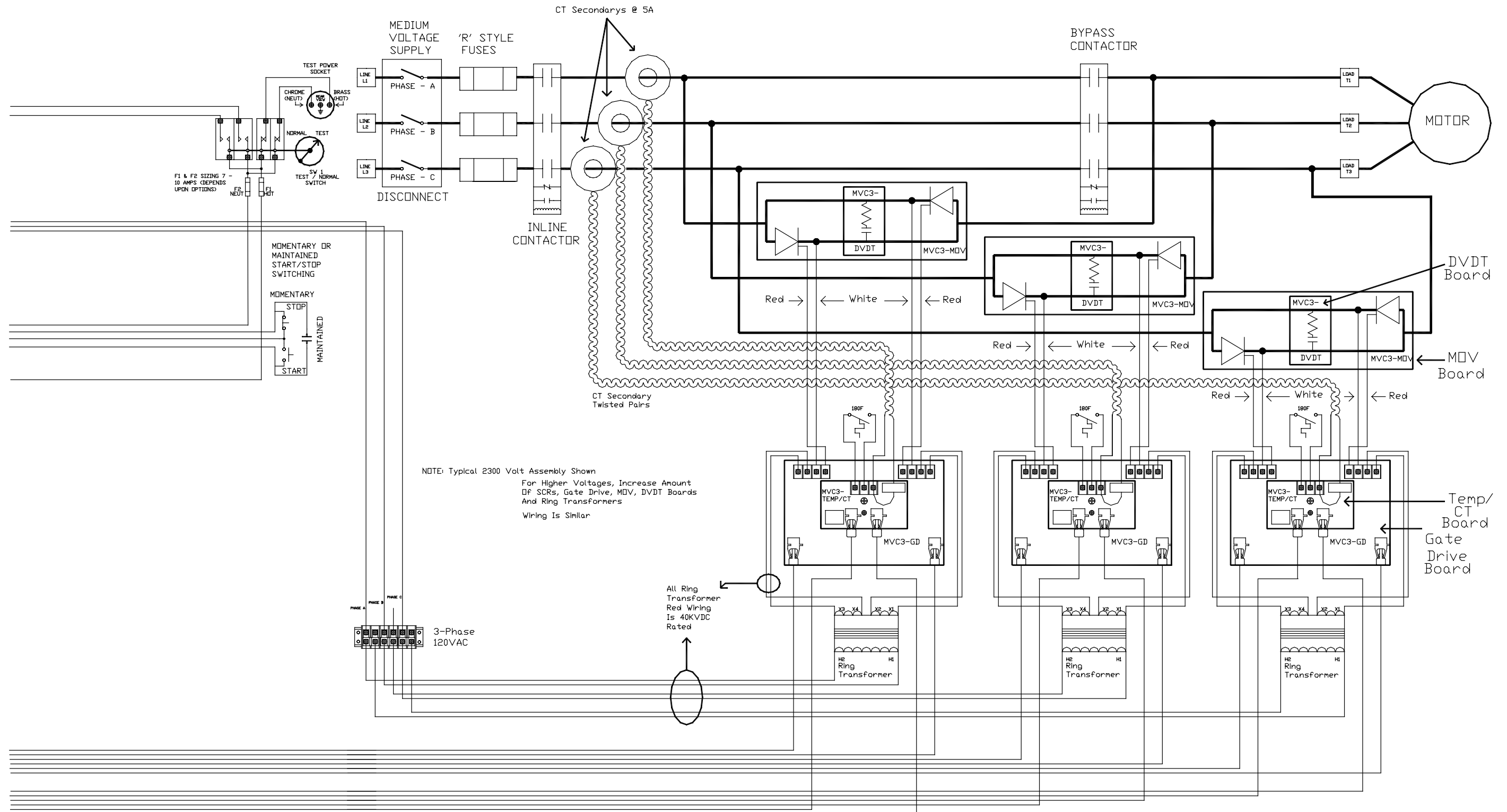

Chapter 7 - Maintenance and Troubleshooting

7.7 - Typical Wiring & Interconnect Diagram for "Soft Start Only" (Models Rated 2300 - 7200V) (Requires customer supplied line start panel)

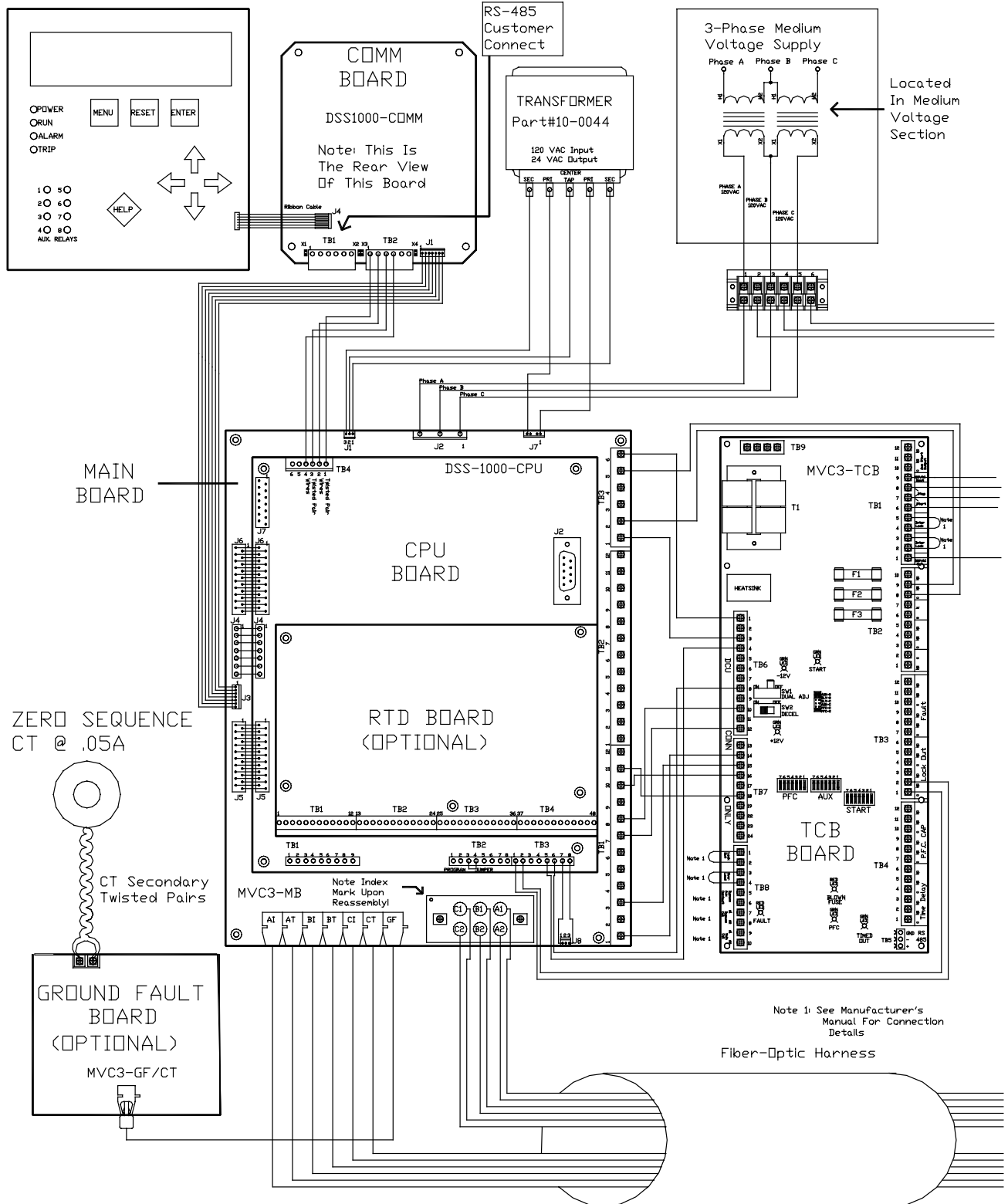

Chapter 7 - Maintenance and Troubleshooting

Typical Wiring & Interconnect Diagram for "Soft Start Only"

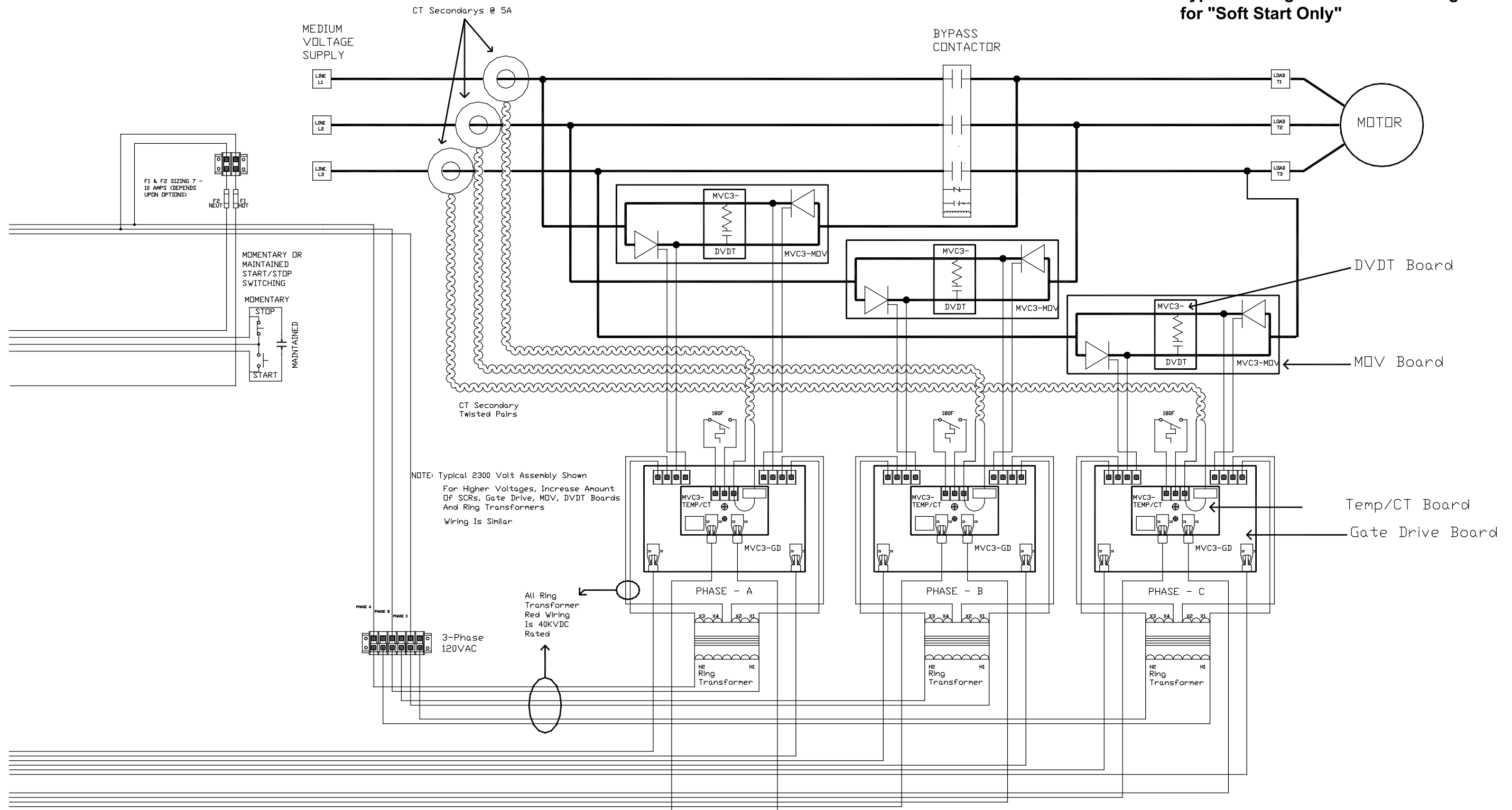

Chapter 7 - Maintenance and Troubleshooting

7.8 - Mechanical Drawings

2300/3300/4160V 200 - 400A Standard SSM Class E2 Soft Starter

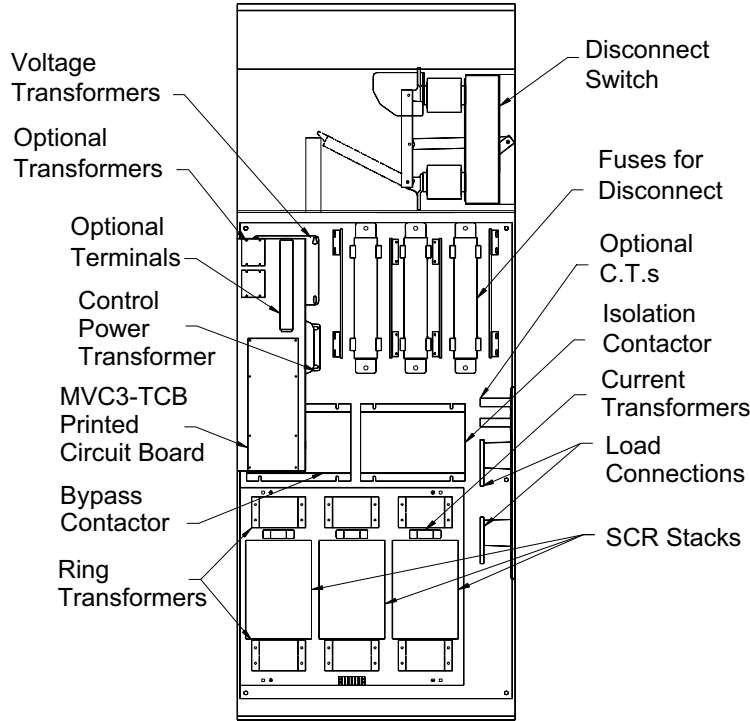

Front View
Door not shown for clarity

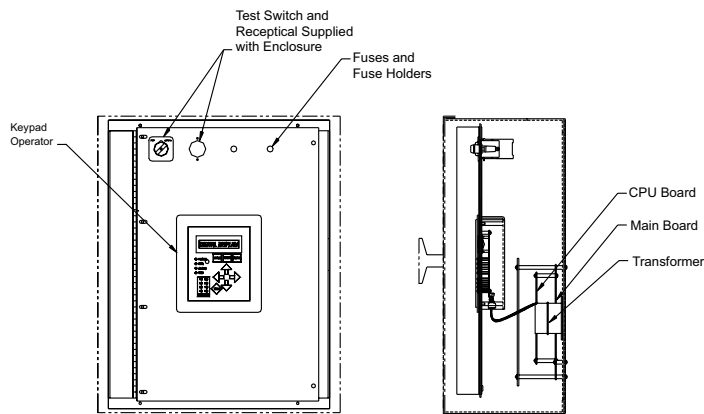

LOW VOLTAGE COMPARTMENT
(LOCATED IN ENCLOSURE DOOR)

Chapter 7 - Maintenance and Troubleshooting

2300V, 600A Standard SSM Class E2 Soft Starter

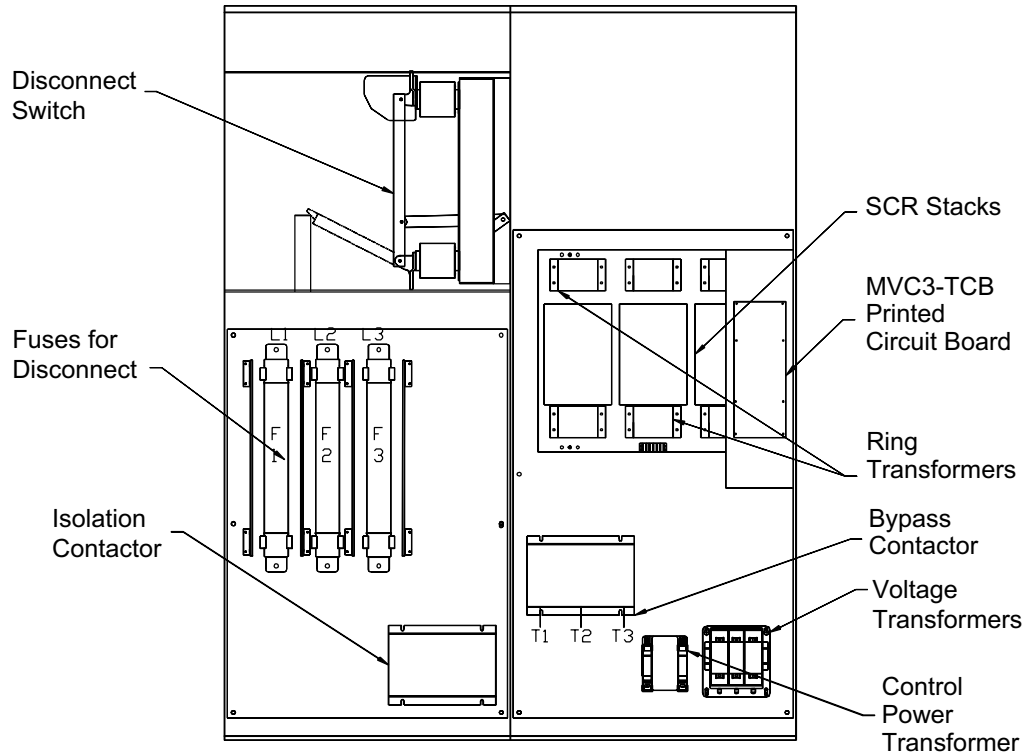

Front View
Door not shown for clarity

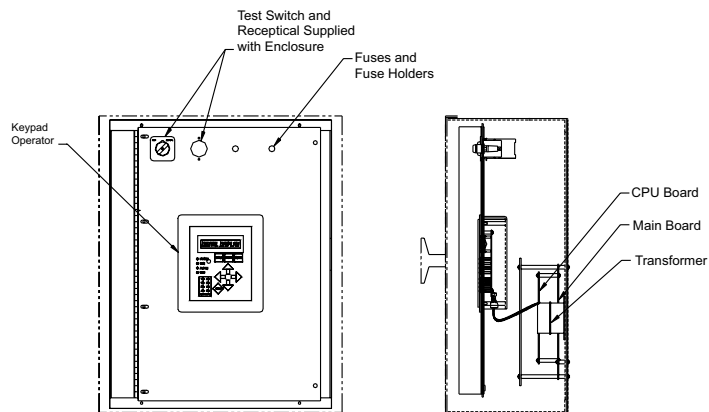

LOW VOLTAGE COMPARTMENT
(LOCATED IN ENCLOSURE DOOR)

Chapter 7 - Maintenance and Troubleshooting

3300/4160V 600A Standard SSM Class E2 Soft Starter

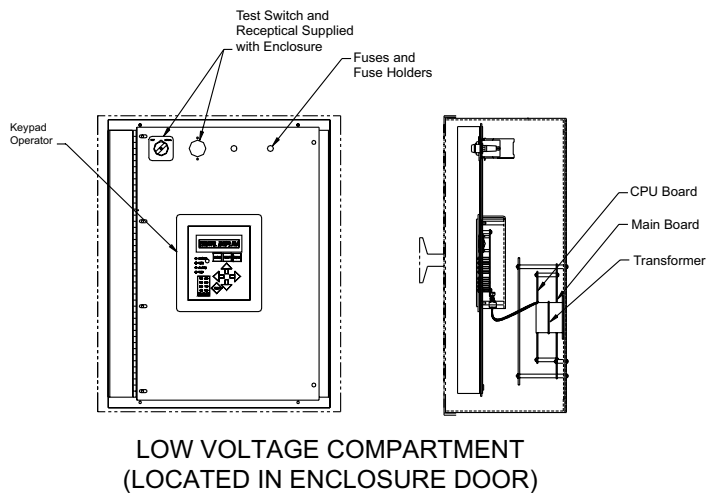
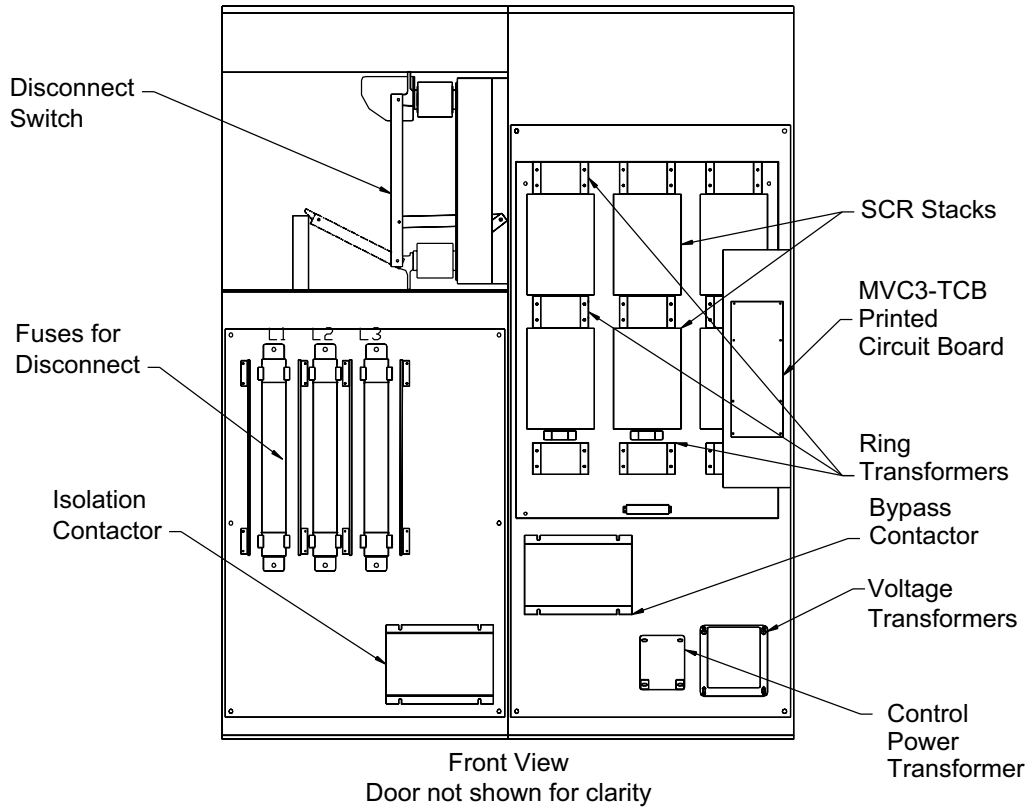

Chapter 7 - Maintenance and Troubleshooting

6000 - 7200V 200 - 400A Standard SSM Class E2 Soft Starter

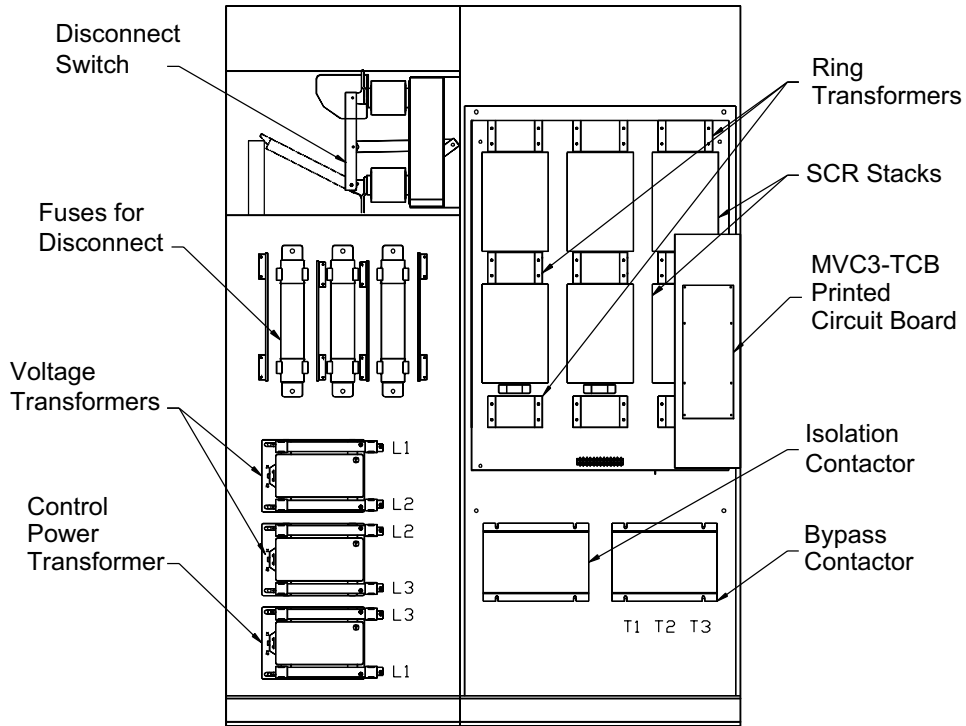

Front View
Door not shown for clarity

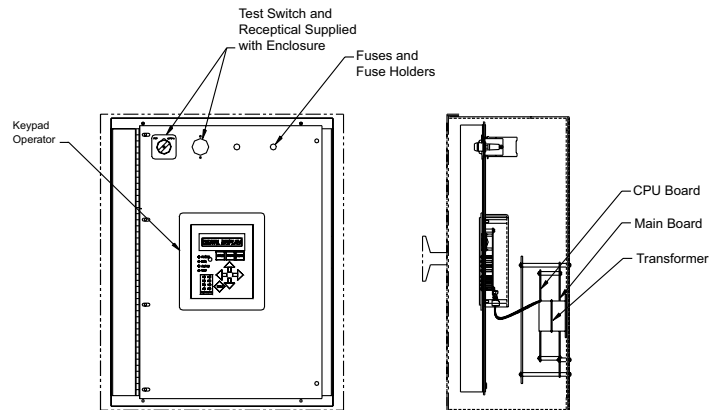

LOW VOLTAGE COMPARTMENT
(LOCATED IN ENCLOSURE DOOR)

Chapter 7 - Maintenance and Troubleshooting

6000 - 7200V 600A Standard SSM Class E2 Soft Starter

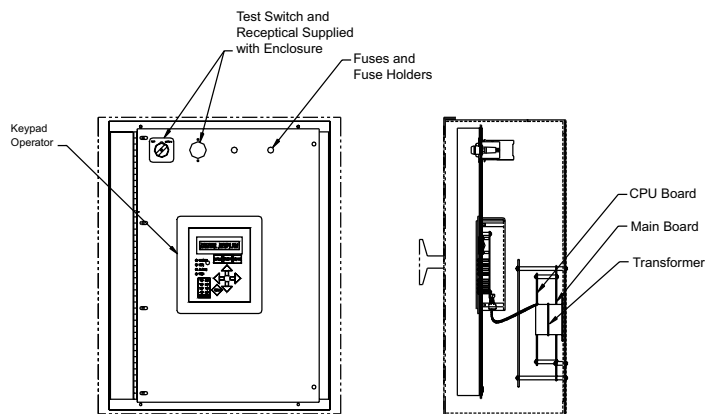
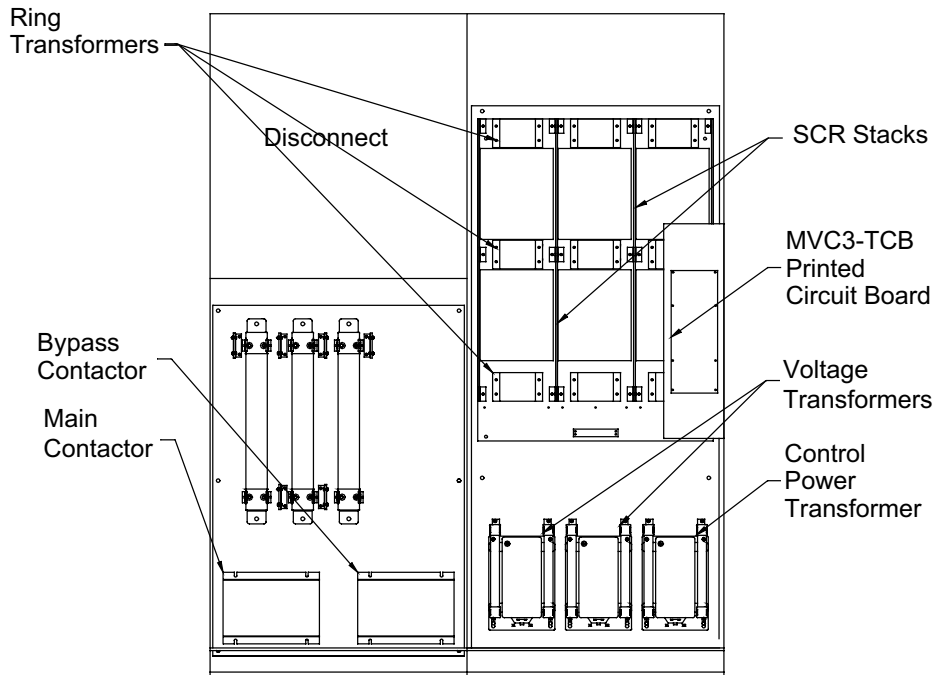

LOW VOLTAGE COMPARTMENT
(LOCATED IN ENCLOSURE DOOR)

Chapter 7 - Maintenance and Troubleshooting

2300/3300/4160V, 200 - 400A Optional Soft Start Only (Requires Customer Supplied Line Start Panel)

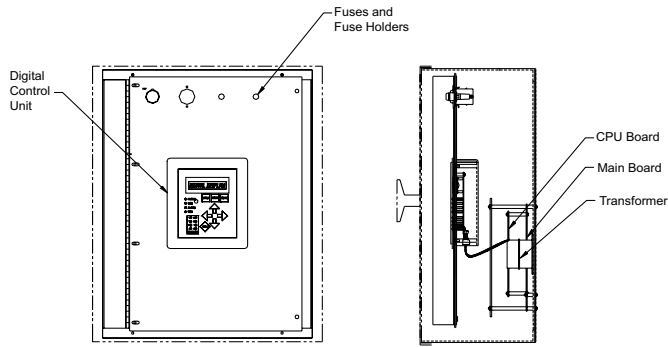

LOW VOLTAGE COMPARTMENT
(LOCATED IN ENCLOSURE DOOR)

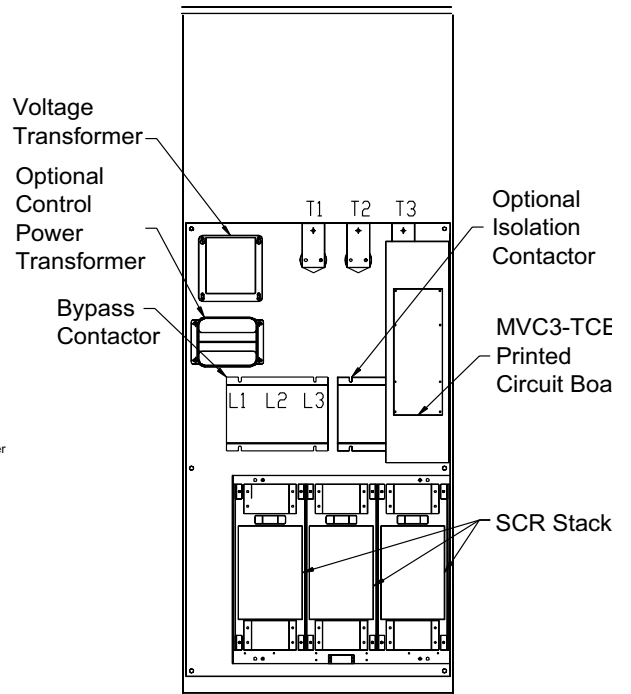

Front View
Door not shown for clarity

2300V, 600A Optional Soft Start Only (Requires Customer Supplied Line Start Panel)

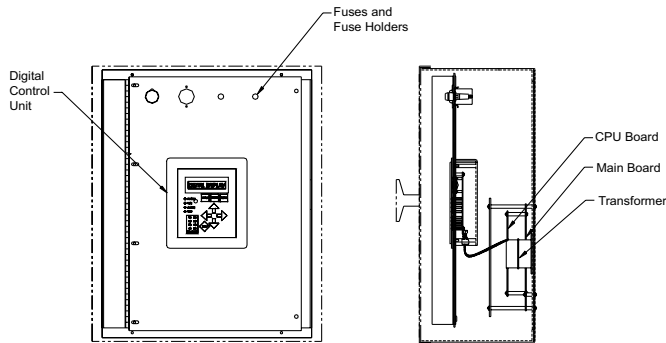

LOW VOLTAGE COMPARTMENT
(LOCATED IN ENCLOSURE DOOR)

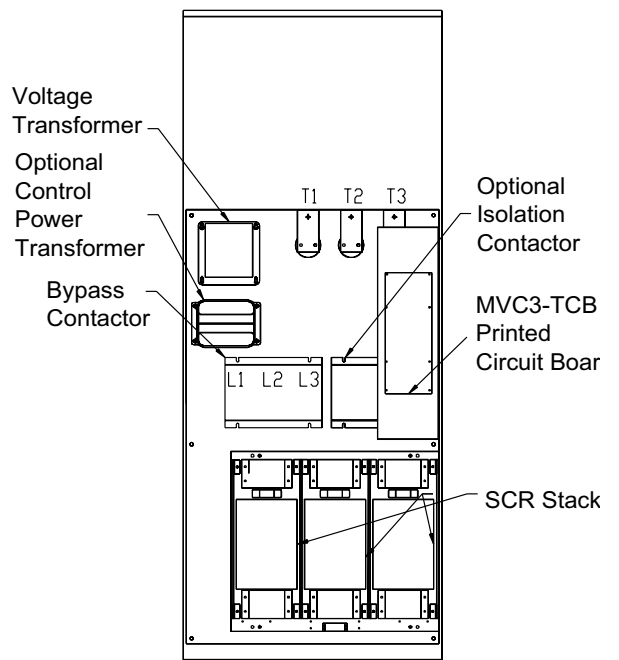

Front View
Door not shown for clarity

Chapter 7 - Maintenance and Troubleshooting

3300/4160V, 600A

Optional Soft Start Only

(Requires Customer Supplied Line Start Panel)

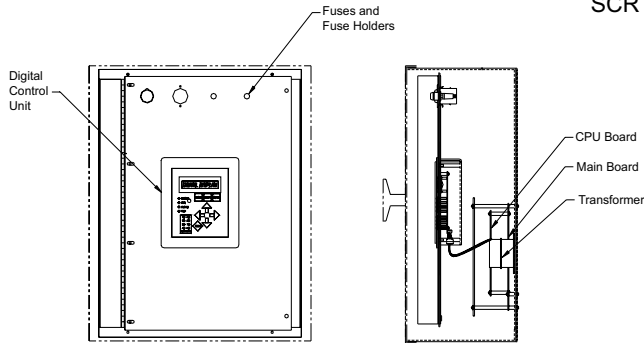

LOW VOLTAGE COMPARTMENT
(LOCATED IN ENCLOSURE DOOR)

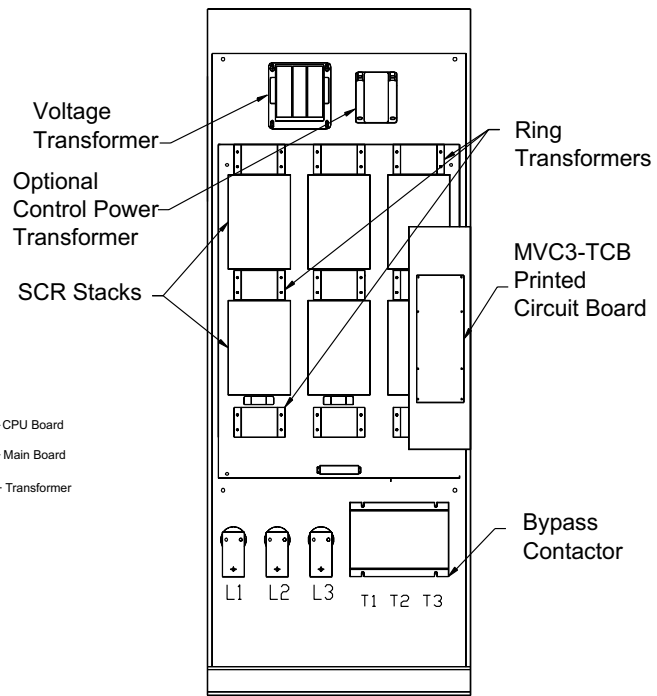

Front View
Door not shown for clarity

6000 - 7200V, 200 - 400A

Optional Soft Start Only

(Requires Customer Supplied Line Start Panel)

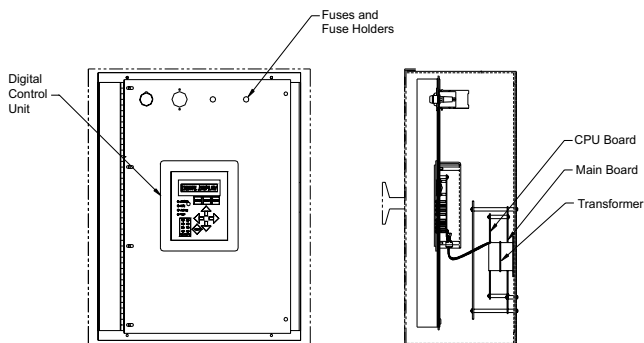

LOW VOLTAGE COMPARTMENT
(LOCATED IN ENCLOSURE DOOR)

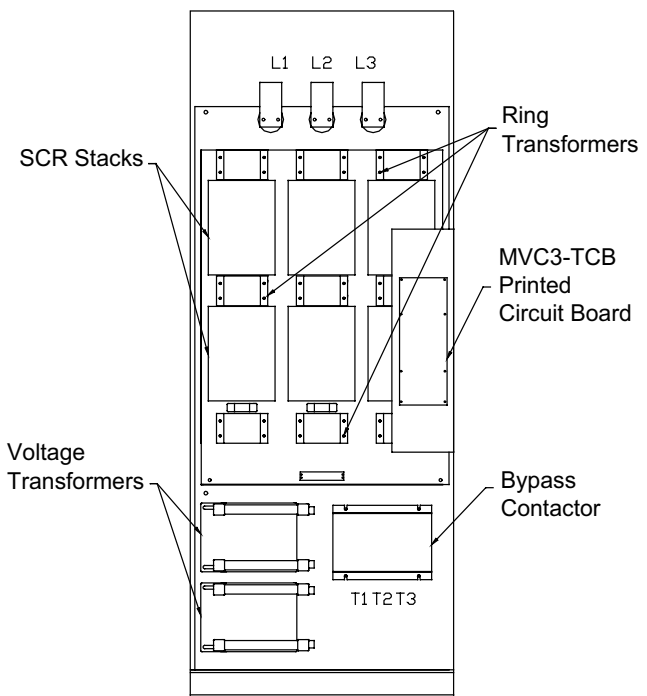

Front View
Door not shown for clarity

Chapter 7 - Maintenance and Troubleshooting

6000 - 7200V, 600A

Optional Soft Start Only

(Requires Customer Supplied Line Start Panel)

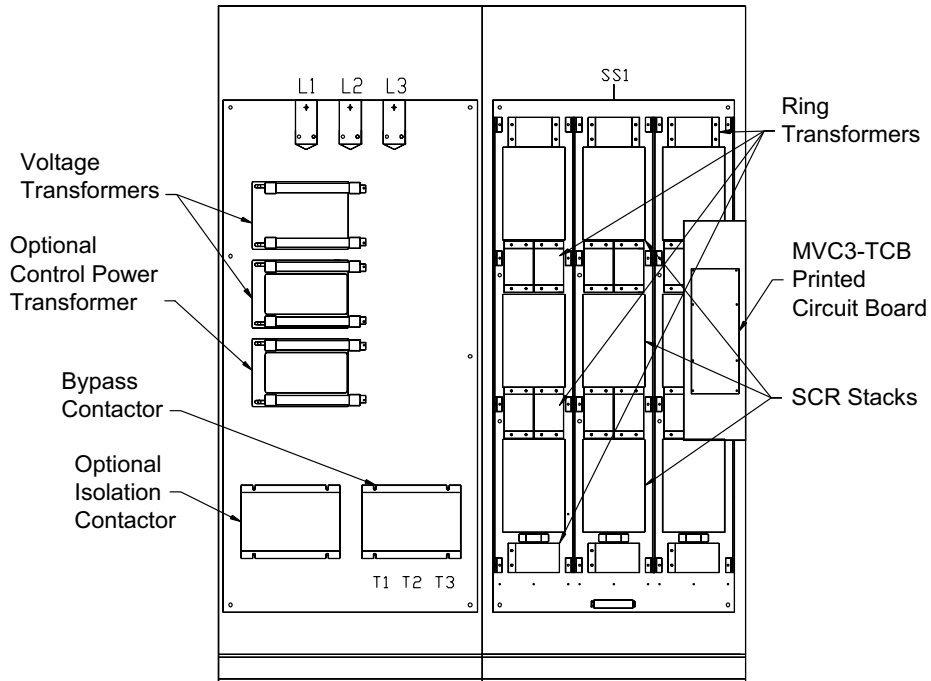

Front View
Door not shown for clarity

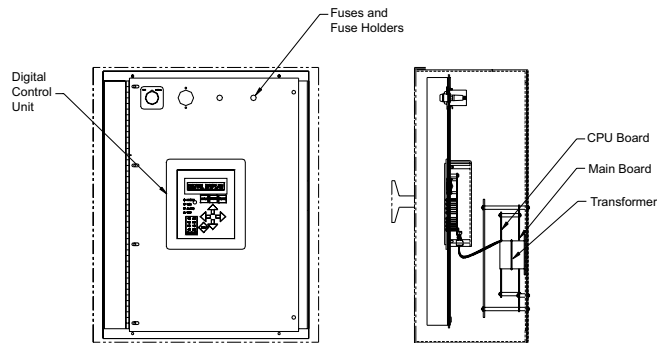

LOW VOLTAGE COMPARTMENT
(LOCATED IN ENCLOSURE DOOR)

Chapter 7 - Maintenance and Troubleshooting

7.9 - Elevation Drawings

2300/3300/4160V 200 - 400A Standard SSM Class E2 Soft Starter

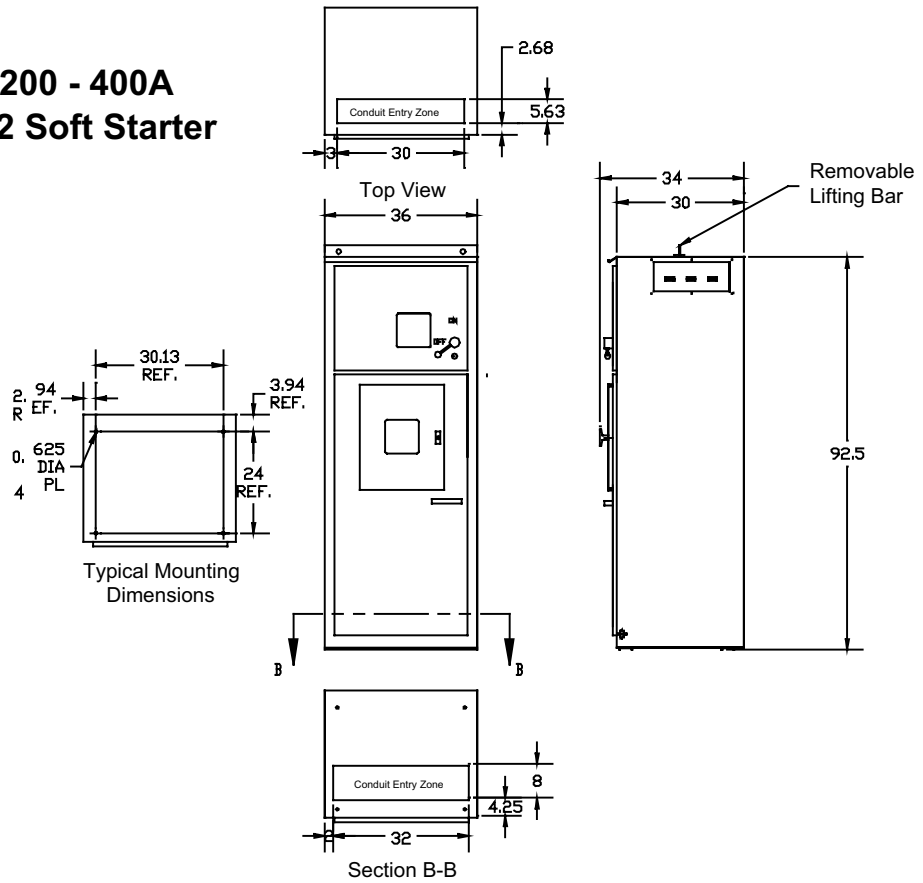

Chapter 7 - Maintenance and Troubleshooting

2300/3300/4160/6000/6600/7200V 600A Standard SSM Class E2 Soft Starter

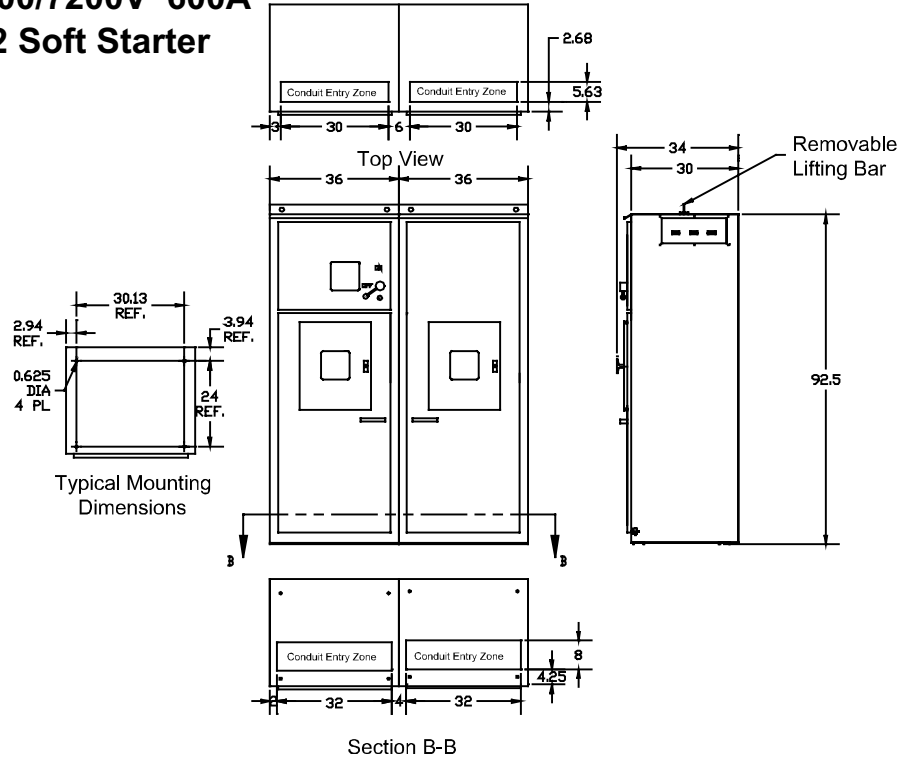

Chapter 7 - Maintenance and Troubleshooting

2300/3300/4160V, 200 - 600A

6000 - 7200V, 200 - 400A

Optional Soft Start Only

(Requires Customer Supplied Line Start Panel)

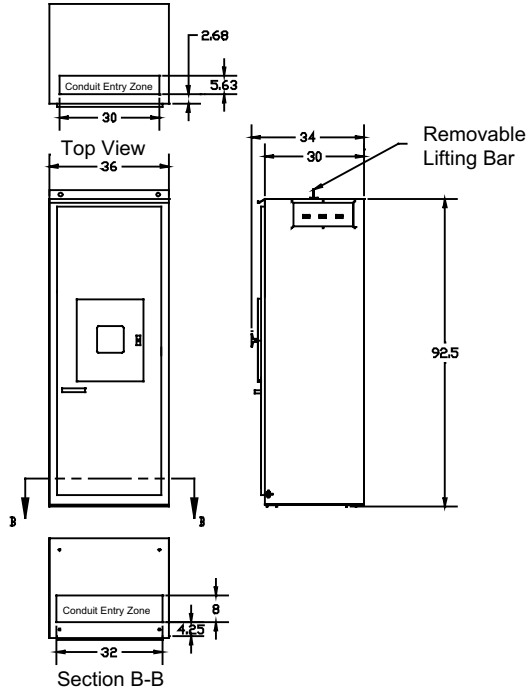
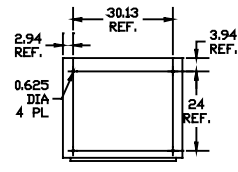

6000 - 7200V, 600A

Optional Soft Start Only

(Requires Customer Supplied Line Start Panel)

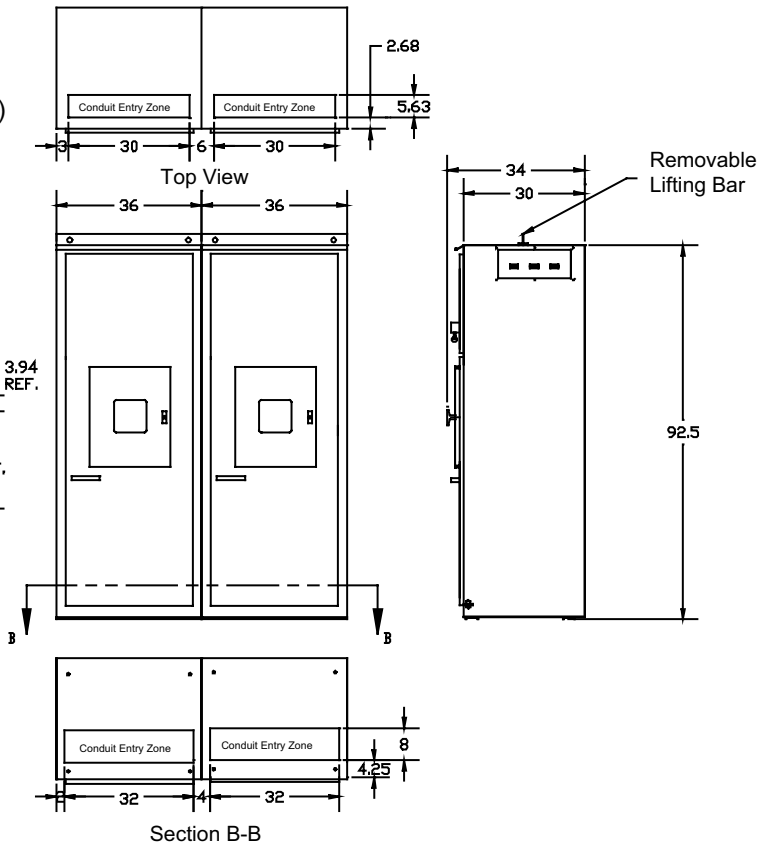
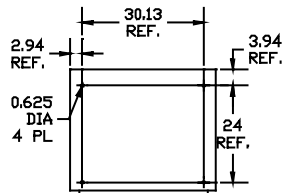

Chapter 7 - Maintenance and Troubleshooting

7.10 - Spare Parts List

Dwg. Ref.#	Description	Part Number	Unit Voltage and Amp Rating	Quantity Req./Unit
1.	Current Transformer	Call Factory	Specify model number	3
2.	Heatsink Assembly with Boards (1 Phase)	MVC3-STK23200	2300V, 200A	3
		MVC3-STK23400	2300V, 400A	3
		MVC3-STK23600	2300V, 600A	3
		MVC3-STK41200	3300/4160V, 200A	3
		MVC3-STK41400	3300/4160V, 400A	3
		MVC3-STK41600	3300/4160V, 600A	3
		MVC3-STK72200	6000 - 7200V, 200A	3
		MVC3-STK72400	6000 - 7200V, 400A	3
3.	SCR(s) Clamped in Heat Sink Alone	25-0200-6500-23	2300V, 200A	3
		25-0400-6500-23	2300V, 400A	3
		25-0600-3500-23	2300V, 600A	3
		25-0200-6500-41	3300/4160V, 200A	3
		25-0400-6500-41	3300/4160V, 400A	3
		25-0600-3500-41	3300/4160V, 600A	3
		25-0200-6500-72	6000 - 7200V, 200A	3
		25-0400-6500-72	6000 - 7200V, 400A	3
4.	Gate Drive Transformer	10-0090	2300V, 200A & 400A	3
		10-0090	2300V, 600A	6
		10-0090	3300/4160V, 200A & 400A	6
		10-0090	3300/4160V, 600A	12
		10-0090	6000 - 7200V, 200A & 400A	9
		10-0090	6000 - 7200V, 600A	12
5.	Voltage Transformers	10-0068	2300V	1
		10-0072-50	3300 V	2
		10-0067	4160V	1
		10-0084	6000 - 7200 V	2
6.	Control Power Transformers	10-0080	2300V	1
		10-0072-50	3300V	1
		10-0083	4160V	1
		10-0084	6000 - 7200V	1
7.	Temperature & Current Board	MVC3-Temp/CT-PS	All models	3

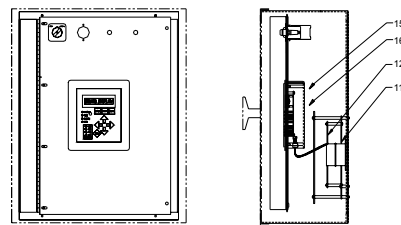
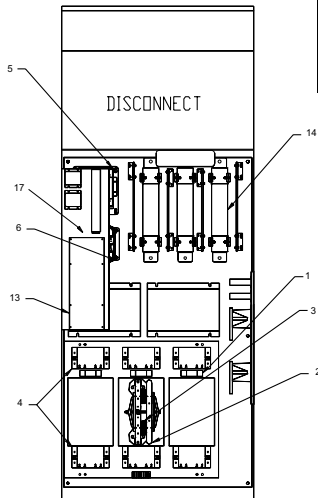

LOW VOLTAGE COMPARTMENT
(LOCATED IN ENCLOSURE DOOR)

Chapter 7 - Maintenance and Troubleshooting

Dwg. Ref.#	Description	Part Number	Unit Voltage and Amp Rating	Quantity Req./Unit
8.	Gate Drive Boards	MVC3-GD	2300V, 200A & 400A	3
		MVC3-GD	2300V, 600A	6
		MVC3-GD	3300/4160 V, 200A & 400A	6
		MVC3-GD	3300/4160 V, 600A	12
		MVC3-GD	6000 - 7200V, 200A & 400A	15
		MVC3-GD	6000 - 7200V, 600A	18
9.	MOV Board	MVC2-MOV	2300V, 200A & 400A	3
		MVC2-MOV	2300V, 600A	6
		MVC2-MOV	3300/4160 V, 200A & 400A	6
		MVC2-MOV	3300/4160 V, 600A	12
		MVC2-MOV	6000 - 7200V, 200A & 400A	15
		MVC2-MOV	6000 - 7200V, 600A	18
10.	Dv/Dt Board	MVC2-Dv/Dt	2300V, 200A & 400A	3
		MVC2-Dv/Dt	2300V, 600A	6
		MVC2-Dv/Dt	3300/4160 V, 200A & 400A	6
		MVC2-Dv/Dt	3300/4160 V, 600A	12
		MVC2-Dv/Dt	6000 - 7200V, 200A & 400A	15
		MVC2-Dv/Dt	6000 - 7200V, 600A	18
11.	Main Firing Board	MVC3-MB-MTR	All models	1
12.	Digital Controller	MVC3-CPU-MTR	All models	1
13.	Control Board	MVC3-TCB	All models	1
14.	Medium Voltage Fuses	Contact Factory	Specify model number	Contact Factory
15.	Communications Board	DSS1000-COM	All models	1
16.	RTD Board	DSS1000-RTD	Option	1
17.	Ground Fault Board	MVC3-GFCT	Option	1
18.	Ground Fault CT	11-0029B	Option	1

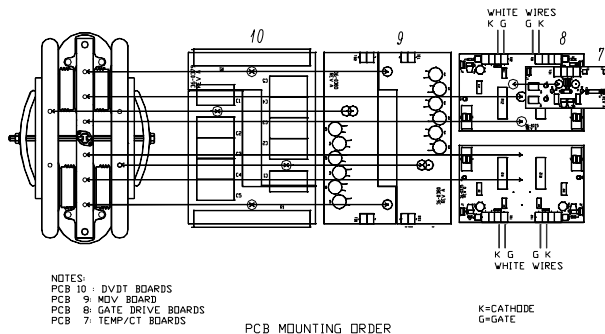

Chapter 7 - Maintenance and Troubleshooting

7.11 - Instructions for Stack Replacement (For Reference Only)



TEMP / CT Board

Gate Drive Board

MOV Board

DV/DT Board

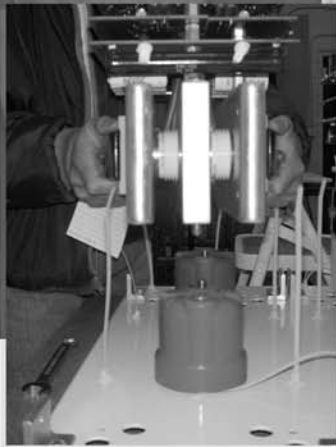

2300/3300/4160V, 200 - 400A
Optional Soft Start Only
 (Requires Customer Supplied Line Start Panel)

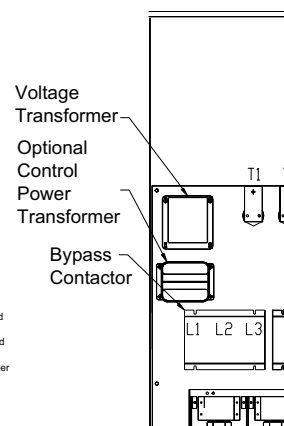
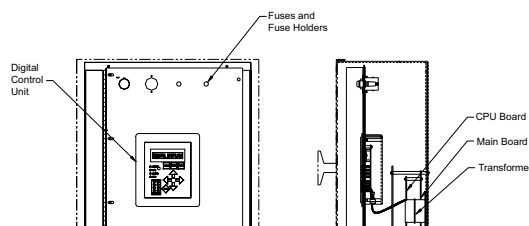

Chapter 7 - Maintenance and Troubleshooting

7.12 - Instructions for Stack Replacement



Note: All power sources must be removed and a waiting period of at least 15 minutes must be observed before initiating any repairs to the unit(s) because DC voltage may still be present immediately after turning off power to the unit.

Note: It is good practice to disassemble and reassemble one stack at a time so you can have an assembled and wired stack in the unit as a reference.

Note: It is recommended that the order include the SCR with the heatsink assembly at a minimum. Only an experienced technician should attempt to replace the SCRs.

Tools:

- Phillips screwdriver
- 3/8" 12 point socket set
- 2 9/16" wrenches
- 1/2" wrench
- AC/DC Multimeter
- Manual (refer to drawings in this section)

Procedure:

1. Verify that no DC or AC voltage is present on any of the power components.
2. Disconnect all four wires connected to TB1 positions 1-3 on the temperature CT board.
3. Disconnect the 4 red transformer wires on each of the gate drive boards. These would be TB1, positions 3 and 5 for each gate drive board. Typically, the 2300V unit will have only 4 wires per phase to disconnect, a 4160V unit will have 8 wires per phase and a 6000 - 7200V unit will have 12 wires per phase (Note: the 6000 - 7200V/600 amp unit will also have 24 wires.)
4. Use the 9/16 wrench and carefully unbolt all of the line and load power connections attached to the heat sinks. Note: If the unit is a 6000 - 7200V, remove the power strap connecting one side of the stack to the stack directly below it.
5. Before removing the fiber optic wiring, make a note of the label on the fiber cable to ensure they are placed exactly in the same socket they were removed from. Now remove all fiber optic connectors on the stack. Gently push on the connector tab and pull with a gentle left-to-right motion on the connector in the direction away from the fiber optic device. Two connectors will be found per gate drive board and one duplex connector will be found on the small Temp/CT board on top. Caution: Do not touch the tip of the connectors or contaminate the connection sockets with any dust or foreign material.
6. Remove the wires from the Temp/CT board terminal block (3 screws)
7. Use a 9/16" socket with a 6" extension to remove the lower bolt that routes through the front face of the heat sink and into the isolation standoff mounted to the white panel. Then carefully hold the heat sink in place with one hand and remove the top bolt from the heat sink.
8. Ensure the fiber optic connectors and all wires are positioned out of the way, and then the heat sink can be gently removed from the unit.

Chapter 7 - Maintenance and Troubleshooting

SCR Replacement:

1. Remove white jumper wires on the gate drive board and make a note of their placement.
2. Remove both 7/16 bolts and single 10 - 32 screw at the top of gate drive board and lift off the board.
3. To remove the MOV board, remove the SCR gate/cathode leads (thin red and white wires) and the white jumper wires attached to them. Make a note as to how they were connected. Unbolt the ½" fasteners as well.
4. At this point, all boards should now be removed from the aluminum heat sink assembly.
5. Make a note (or drawing) of how each of the SCRs are oriented within the heat sink. If factory supplied replacement SCRs and heatsinks are used, the following steps are not required.
6. Loosen and carefully remove the ½" feed-through bolt and two black springs that hold the assembly together and turn it on its side.
7. Remove the two (2) SCRS in the top layer, making certain to note that the SCRs are not facing the same direction.
8. Remove the two (2) SCRs in the bottom layer, also making certain to note that the SCRs are not facing the same direction.
9. Clean the heat sink surface area thoroughly and reapply some thermal heat sink grease sparingly to the SCRs mating surfaces.
10. Please note that replacement SCRs are in matched sets of four and as such, please try to keep the matched sets within the same phase.
11. Now, take any two SCRs from a set and place them on the heat sink in the same direction as the old SCRs were, ensuring that the dimple in the center of the SCR is properly placed onto the center pin of the heat sink assembly. Place the next level of heat sink bar on the mounted SCRs. Note: There is a difference in the heat sink bars. The center bar has more holes drilled in it for mounting the circuit boards on it.
12. Now replace the other two (2) SCRs by repeating steps 10 and 11.
13. Next, carefully sandwich the SCRs and turn the stack over so the heat sink bars are vertical and run the center bolt through the springs and hand tighten the nut on the center bolt assembly.
14. Then make approximately 3 and ½ full revolutions on the nut to create the appropriate amount of compression force. You can tell if there is enough compression force applied to the heat sink by the fact that the force needed to turn the nut will suddenly increase.
15. Finally, reinstall all boards in the same manner in which they were removed.
16. Refer to drawing PCB mounting order drawings for disassembling and reassembling the stack assembly.

Reinstallation:

1. Hold the rebuilt or new stack assembly in the vertical position with the Temp/CT board on top (only the top stack assembly will have this board in a multi-stack phase) and place the stack on the positioning studs that protrude from the isolation standoffs.
2. While pressing on the stack to hold it on the positioning studs, place the feed-through bolt through the heat sink and finger-tighten the top bolt. Then repeat the process with the bottom feed-through bolt to ensure the stack is held against the isolation standoffs.
3. After verifying no wires or fibers have been pinched between the stack assembly and isolation standoffs, tighten the top bolt completely, then repeat the process for the bottom bolt. Now the stack assembly should be held firmly in place.
4. Using the 9/16" wrench reinstall the line and load power cables and tighten.

Chapter 7 - Maintenance and Troubleshooting

5. If needed, refer to the appropriate drawing to reconnect red transformer wires on each gate drive board. As an example, for the 4160V stack, reattach TB4-1 to X3, TB4-3 to X4, TB1-3 to X2 and TB1-1 to X1. Verify all X(#) wires are reconnected to their original position on the gate drive boards. Otherwise the SCRs will misfire.
6. Reconnect thermostat wires on TB1 positions 2 and 3 of the Temp/CT board.
7. Reconnect the main CT black wire to TB1-1. Then feed the white wire through the board mounted CT and connect to TB1-1 on the Temp/CT board. Please note that one each of the thick white wires from the encapsulated CT must be connected with the Main CTs wiring.
8. Ensure the same fiber optic routing is used as before. If the fiber optic wiring is positioned close to a heat source, (such as the 25-watt resistors on the gate drive board) melting or distortion of the plastic fiber may occur. Minimum distance is a ½ inch with a minimum bend radius of 2 inches. All gate drive boards require 2 single connectors per board and the Temp/CT connector is a duplex piece with a mating tab that faces away from the stack. If the tab is broken off, refer to an adjacent stack's labels to see how the labels should be positioned when installing a duplex connector with a broken tab. Again, caution should be taken not to touch the fiber connector end or force it in with the tab facing down.

Chapter 7 - Maintenance and Troubleshooting

7.12 - Instructions for Low Voltage Test

Tools:

 DANGER

HAZARDOUS VOLTAGE

Disconnect all power supplying this equipment prior to working on it.

Failure to follow this instruction will result in death or serious injury.

- Phillips screwdriver
- Medium voltage fuse pullers if available
- Two control power transformer (Test PT) 500 VA minimum
- 120 VAC control power (Test plug)
- Low voltage motor strapped for the proper voltage (typically 5 HP or less)
- Oscilloscope if available
- Wire jumper
- Test switch (single pole i.e. - light switch)
- Manual (reference drawing above)

Procedure:

 DANGER

HAZARDOUS VOLTAGE

Remove all medium voltage fuses to prevent back-feeding transformers.

Failure to follow this instruction will result in death or serious injury.

Construct an open delta low voltage source for powering the SSM for low voltage testing (Minimum of 500VA each)

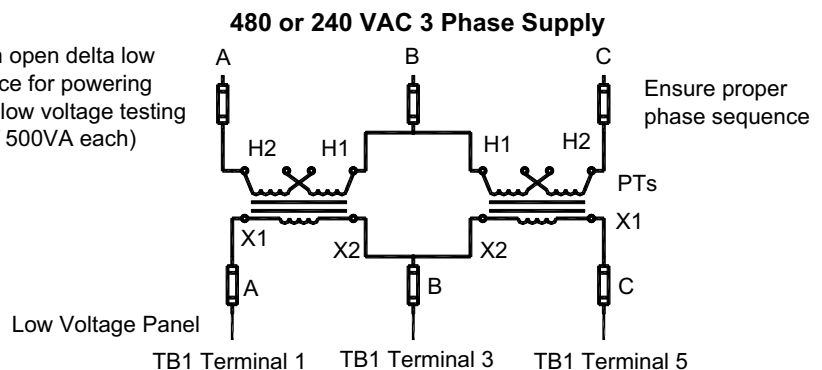

1. Verify that no DC or AC voltage is present on any of the components.
2. Verify setup of control power transformer for the proper voltage. If using 480 or 240 VAC 3 phase verify transformers are strapped for that voltage. See above drawing. Configure as an open delta for 3 phase as shown in drawing.
3. Verify medium voltage disconnect is open and pull medium voltage fuses including VT and CPT fuses.
4. Connect 3 phase power 480 or 240 VAC to the downstream side of the fuses. Do not connect to disconnect side of fuses. The size of the small test motor will dictate the current drawn and minimum cable size for connection. Also, connect the Primaries of the TEST PT in the proper phase sequence of A-B-C.
5. Disconnect medium voltage motor.
6. Connect low voltage motor. (Typically 5 HP or less)
7. Connect a wire jumper between TB8 pins 1 and 2 on the TCB (control board) to bypass fuse blown and open disconnect fault. The TCB is located in the medium voltage compartment.
8. Install a switch on TB1 pins 1 and 8 on the TCB (control board) to bypass all interlocks (Interlock Switch).

120 VAC 3 Phase Output

Connect to MVC3-MB (Main Firing Board)

Caution: Remove the three phase transformer PT fuses and CPT fuses on panel to prevent backfeed to the Medium Voltage

Chapter 7 - Maintenance and Troubleshooting

9. Verify or wire a 120 VAC plug to the TEST plug supplied by the factory. (Line start packages only)
10. Remove both control power fuses on the medium voltage CPT (single phase control power transformer)
11. Remove 3 fuses from the medium voltage potential transformer (PT)
12. Verify the 120-volt test switch is in the "NORMAL" position. (Line start package only)
13. Connect test power to test plug connector and place the 120-volt test switch to the "TEST" position.
14. The keypad should be energized with the "Power LED," Stop LED
15. Close the temporary Start switch, which is connected to the control board.
16. The Main Vacuum contactor should close and the keypad should trip on "Under Voltage" Open temporary Interlock switch and reset CPU fault.
17. Connect the Secondary of the TEST PT to Panel TB1 positions 1 - phase A, position 3- phase B, and position 5 - phase C on the main firing board (MVC3-MB). It is physically located behind the low voltage compartment door. (Screw terminal block)
18. Verify all connections are good and then energize the low voltage of either 480 or 240 volt, three phases.
19. Use the multimeter on the AC scale and verify 3 phase 120 VAC (phase to phase) at TB1 pins 1, 3 and 5 of the main firing board.
20. If all 120 VAC 3 phase is present then de-energize low voltage of 480 or 240 VAC.
21. Re-energize the low voltage of 480 or 240 VAC.
22. Now all test voltages should be present 480 or 240 VAC and three phase 120 VAC (TEST PT) and 120 VAC single phase for control power.
23. Close the temporary Start switch and the test motor should spin up smoothly.
24. Use the Multimeter on the AC scale and check (phase to phase) voltages on T1, T2 and T3 motor leads. The voltages should be balanced.
25. If the motor doesn't spin up smoothly the soft starter is malfunctioning. Proceed to step 27 for troubleshooting.
26. If the motor starts and runs smoothly then repeat this procedure in reverse to remove all test connections and reinstall all fuses.

Chapter 7 - Maintenance and Troubleshooting

Low Voltage Troubleshooting:

Tools: Ungrounded Oscilloscope

27. Open test switch and stop motor.
28. Change Setpoint Page 5 AUX4 is set at non-fail safe. Change it to fail safe.
29. Observe bypass contactor closes immediately.
30. Place the Oscilloscope on the 2msec time scale and 1 v per division.
31. Connect the Oscilloscope probe to the Gate and Cathode of the SCRs.
32. The gate and cathode leads are the white wires on the gate drive board in the medium voltage cabinet. See drawing below.
33. If waveform is inverted, swap Oscilloscope connections for proper polarity. Close the temporary Start switch and allow the test motor to reach full speed.
34. Then verify all gating signals to each SCR (two gating signals on every gate drive board). See drawing below for correct waveform.
35. Once the bad signal(s) are found; write down the location and call the factory for further guidance.

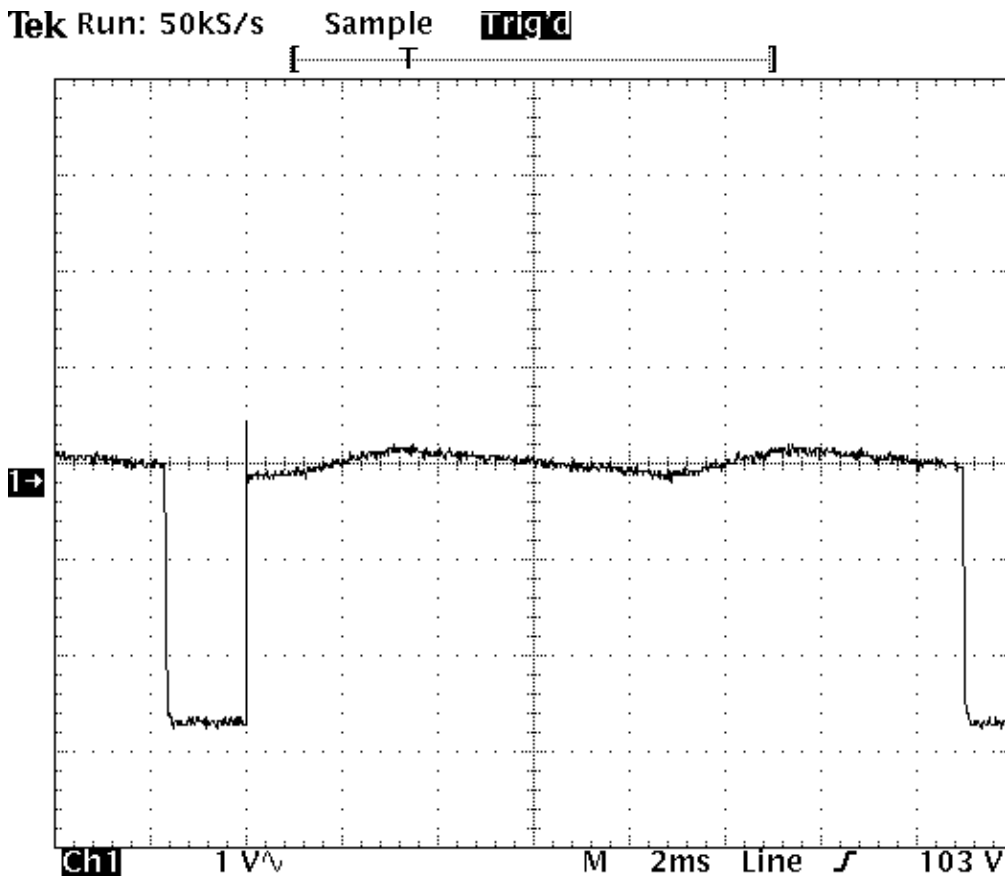

Waveform is the gating signal as measured with an ungrounded o'scope at the gate to cathode of the SCR. The waveform should be 1.7 to 2msec off time and approximately 1.5 to 3 Vdc. This signal is only present at full conduction or the motor is at speed. Each SCR gating signal should be checked in accordance with the low voltage test procedure.

Correct Waveform

Chapter 8 - Commissioning and Warranty

8.1 - Installation Data Sheet

Startup Date:	Model #:	Serial # :
Owner (End user)		
Company Name :		
Address:		State:
		Zip Code:
Contact:	Phone:	Fax:
Purchased from (Distributor) :		
Motor Information		
Type of Motor: <input type="checkbox"/> Standard Induction <input type="checkbox"/> Synchronous <input type="checkbox"/> Wound Rotor		Serial # _____
MOTOR NAMEPLATE DATA		If synchronous motor:
HP:	SF:	Mfgr:
		<input type="checkbox"/> Brush <input type="checkbox"/> Brushless
		Secondary Volts:
VOLTAGE:	LRA:	Field Amps:
		Secondary Amps:
FLA:	NEMA Design:	Field Discharge Resistor (ohms):
RPM:	Frame:	Secondary Resistance (ohms):
FREQ:	KVA Code:	Other Info:
Application Information		
Type of driven load:		
Mfgr. of driven equipment:	Model #:	Serial #:
Power System		
<input type="checkbox"/> Utility Power	Transformer Rating: _____ kVA	<input type="checkbox"/> Generator Power
		Generator Rating: _____ kW
Power cable run from source to starter: _____ FT. (approx)		Power cable run from starter to motor: _____ FT. (approx)
<input type="checkbox"/> Power Factor / Surge Capacitors moved to line side of solid state starter or removed. DANGER: Equipment may be damaged or personal injury may result if equipment is started with power factor capacitors or surge capacitors connected on the load side of solid state motor controls.		
Startup Procedures (See Chapters 2 & 3 of the manual)		
<input type="checkbox"/> Visual Unit Inspection	<input type="checkbox"/> Acceptable Location	<input type="checkbox"/> Proper Connections (Power & Control)
<input type="checkbox"/> Startup procedures followed	<input type="checkbox"/> Proper Adjustments Made	<input type="checkbox"/> Successful Start / Ramp / Run
Name of person completing this report:		Signature:
Warranty Status (For ABB's office use only)		
Date Shipped:	Comments:	
Commissioning/ Start-up performed by (Name):		
Company:	Signature:	
Expiration Date:	Approved by:	

Chapter 8 - Commissioning and Warranty

8.2 - Commissioning Settings

Model #: _____

Serial #: _____

Setpoint Page	Security Level	Description	Factory Setting Default	Range	Setting
Page 1 Basic Configuration	Level 1 No Password Required	Motor Full Load Amps (FLA)	Model dependent	50 - 100% of Unit Max Current Rating (Model and Service Factor dependent)	
		Service Factor	1.15	1.00 – 1.3	
		Overload Class	10	O/L Class 5-30	
		NEMA Design	B	A-F	
		Insulation Class	B	A, B, C, E, F, H, K, N, S	
		Line Voltage	4160	100 to 7200V	
		Line Frequency	60	50 or 60 HZ	

Setpoint Page	Security Level	Description	Factory Setting Default	Range	Setting
Page 2 Starter Configuration	Level 1 No Password Required	Start Control Mode	Start Ramp 1	Jog, Start Ramp 1, Start Ramp 2, Custom Accel Curve, Start Disabled, Dual Ramp	
		Jog Voltage	Off	5-75%, Off	
		Start Ramp #1 Type	Voltage	Current, Voltage, Off	
		Initial Voltage #1	20%	0-100%	
		Ramp Time #1	10 sec	0-120 sec	
		Current Limit #1	350% FLA	200-600 %	
		Initial Current #1	200% FLA	0-300%	
		Ramp Time #1	10 sec	0-120 sec	
		Maximum Current #1	350% FLA	200-600 %	
		Start Ramp #2 Type	Off	Current, Voltage, Off	
		Initial Voltage #2	60%	0-100 %	
		Ramp Time #2	10 sec	0-120 sec	
		Current Limit #2	350 % FLA	200-600 %	
		Initial Current #2	200% FLA	0-600 %	
		Ramp Time #2	10 sec	0-120 sec	
		Maximum Current #2	350% FLA	200-600 %	
		Kick Start Type	Off	Voltage or Off	
		Kick Start Voltage	65%	10-100 %	
		Kick Start Time	0.50 sec	0.10-2.00	
		Deceleration	Disabled	Enabled or Disabled	
		Start Deceleration Voltage	60%	0-100 %	
		Stop Deceleration Voltage	30%	0-59 %	
		Deceleration Time	5 sec	1-60 sec	
		Timed Output Time	Off	1-1000 sec, Off	
Run Delay Time	1 Sec	1-30 sec, Off			
At Speed Delay Time	1 Sec	1-30 sec, Off			

Chapter 8 - Commissioning and Warranty

Model #: _____

Serial #: _____

Setpoint Page	Security Level	Description	Factory Setting Default	Range	Setting
Page 3 Phase and Ground Settings	Level 2 Password Protection	Imbalance Alarm Level	15% FLA	5-30 %, Off	
		Imbalance Alarm Delay	1.5 sec	1.0-20.0 sec	
		Imbalance Trip Level	20%	5-30 %, Off	
		Imbalance Trip Delay	2.0 sec	1.0-20.0 sec	
		Undercurrent Alarm Level	Off	10-90 %, Off	
		Undercurrent Alarm Delay	2.0 sec	1.0-60.0 sec	
		Overcurrent Alarm Level	Off	100-300 %, Off	
		Overcurrent Alarm Delay	2.0 sec	1.0-20.0 sec	
		Overcurrent Trip Level	Off	100-300 %, Off	
		Overcurrent Trip Delay	2.0 sec	1.0-20.0 sec	
		Phase Loss Trip	Disabled	Enabled or Disabled	
		Phase Loss Trip Delay	0.1 sec	0-20.0 sec	
		Phase Rotation Detection	Enabled	Enabled Only	
		Phase Rotation	ABC	ABC	
		*Ground Fault Alarm Level	Off	5-90 %, Off	
		*Ground Fault Alarm Delay	0.1 sec	0.1-20.0 sec	
		*Ground Fault Loset Trip Level	Off	5-90 %, Off	
		*Ground Fault Loset Trip Delay	0.5 sec	0.1-20 sec	
		*Ground Fault Hiset Trip Level	Off	5-90 %, Off	
		*Ground Fault Hiset Trip Delay	0.008 sec	0.008-0.250 sec	
		Oversvoltage Alarm Level	Off	5 -30%, Off	
		Oversvoltage Alarm Delay	1.0 sec	1.0-30.0 sec	
		Oversvoltage Trip Level	Off	5-30%, Off	
		Oversvoltage Trip Delay	2.0 sec	1.0-30.0 sec	
		Undersvoltage Alarm Level	Off	5-30%, Off	
		Undersvoltage Alarm Delay	1.0 sec	1.0-30.0 sec	
		Undersvoltage Trip Level	Off	5-30%, Off	
		Undersvoltage Trip Delay	2.0 sec	1.0-30.0 sec	
		Line Frequency Trip Window	Disabled	0-6 Hz, Disabled	
		Line Frequency Trip Delay	1.0 sec	1.0-20.0 sec	
		P/F Lead P/F Alarm	Off	0.1-1.00, Off	
		P/F Lead Alarm Delay	1.0 sec	1-120 sec	
		P/F Lead P/F Trip	Off	.01-1.00, Off	
		P/F Lead Trip Delay	1.0 sec	1-120 sec	
		P/F Lag P/F Alarm	Off	.01-1.00, Off	
		P/F Lag Alarm Delay	1.0 sec	1-120 sec	
		P/F Lag P/F Trip	Off	.01-1.00, Off	
		P/F Lag Trip Delay	1.0 sec	1-120 sec	
		Power Demand Period	10 min	1 - 60 min	
		KW Demand Alarm Pickup	Off KW	Off, 1-100000	
KVA Demand Alarm Pickup	Off KVA	Off, 1-100000			
KVAR Demand Alarm Pickup	Off KVAR	Off, 1-100000			
Amps Demand Alarm Pickup	Off Amps	Off, 1-100000			

Chapter 8 - Commissioning and Warranty

Model #: _____
 Serial #: _____

Setpoint Page	Security Level	Description	Factory Setting			Range	Setting
			1st	2nd	3rd		
Page 4 Relay Assignments	Level 2 Password Protection	O/L Trip	Trip Only	None	None	None Trip(AUX1) Alarm(AUX2) AUX3 AUX4 AUX5-8 Only Available in 8 Relay System Note: AUX1 to AUX4 are for Factory Use only. Do not change!	
		I/B Trip	Trip	None	None		
		S/C Trip	Trip Only	None	None		
		Overcurrent Trip	Trip	None	None		
		Stator RTD Trip	Trip	None	None		
		Bearing RTD Trip	Trip	None	None		
		*G/F Hi Set Trip	Trip	None	None		
		*G/F Lo Set Trip	Trip	None	None		
		Phase Loss Trip	Trip	None	None		
		Accel. Time Trip	Trip Only	None	None		
		Start Curve Trip	Trip Only	None	None		
		Over Frequency Trip	Trip	None	None		
		Under Frequency Trip	Trip	None	None		
		I*I*T Start Curve	Trip	None	None		
		Learned Start Curve	Trip	None	None		
		Phase Reversal	Trip	None	None		
		Overvoltage Trip	Trip	None	None		
		Undervoltage Trip	Trip	None	None		
		Power Factor Trip	Trip	None	None		
		Tach Accel Trip	None	None	None		
		Inhibits Trip	Trip	None	None		
		TCB Fault	Trip	None	None		
		External Input #2	None	None	None		
		Dual Ramp	None	None	None		
		Thermostat	Trip	None	None		
		O/L Warning	Alarm	None	None		
		Overcurrent Alarm	Alarm	None	None		
		SCR Fail Shunt Alarm	None	None	None		
		*Ground Fault Alarm	Alarm	None	None		
		Under Current Alarm	None	None	None		
		Motor Running	AUX3	None	None		
		I/B Alarm	Alarm	None	None		
		Stator RTD Alarm	None	None	None		
		Non-Stator RTD Alarm	None	None	None		
RTD Failure Alarm	None	None	None				
Self Test Fail	Trip	None	None				
Thermal Register	Alarm	None	None				
U/V Alarm	Alarm	None	None				
O/V Alarm	Alarm	None	None				
Power Factor Alarm	None	None	None				
KW Demand Alarm	None	None	None				
KVA Demand Alarm	None	None	None				
KVAR Demand Alarm	None	None	None				
Amps Demand Alarm	None	None	None				
Timed Output	None	None	None				
Run Delay Time	None	None	None				
At Speed	AUX4	None	None				

Chapter 8 - Commissioning and Warranty

Model #: _____

Serial #: _____

Setpoint Page	Security Level	Description	Factory Setting Default	Range	Setting
Page 5 Relay Configuration	Level 2 Password Protection	Trip (AUX1) Fail-Safe	No	Yes or No	
		Trip (AUX1) Relay Latched	Yes	Yes or No	
		Alarm (AUX2) Fail-Safe	No	Yes or No	
		Alarm (AUX2) Relay Latched	No	Yes or No	
		AUX3 Relay Fail-Safe	No	Yes or No	
		AUX3 Relay Latched	No	Yes or No	
		AUX4 Relay Fail-Safe	No	Yes or No	
		AUX4 Relay Latched	No	Yes or No	
		AUX5 Relay Fail-Safe	No	Yes or No	
		AUX5 Relay Latched	No	Yes or No	
		AUX6 Relay Fail-Safe	No	Yes or No	
		AUX6 Relay Latched	No	Yes or No	
		AUX7 Relay Fail-Safe	No	Yes or No	
		AUX7 Relay Latched	No	Yes or No	
		AUX8 Relay Fail-Safe	No	Yes or No	
AUX8 Relay Latched	No	Yes or No			

Chapter 8 - Commissioning and Warranty

Model #: _____
 Serial #: _____

Setpoint Page	Security Level	Description	Factory Setting Default	Range	Setting
Page 6 User I/O Configuration	Level 2 Passowrd Protection	Tachometer Scale Selection	Disabled	Enabled or Disabled	
		Manual Tach Scale 4.0 mA:	0 RPM	0 - 3600	
		Manual Tach Scale 20.0 mA:	2000 RPM	0 - 3600	
		Tach Accel Trip Mode Select	Disabled	Underspeed, Overspeed or Disabled	
		Tach Ramp Time	20 sec	1 - 120	
		Tach Underspeed Trip PT	1650 RPM	0-3600	
		Tach Overspeed Trip PT	1850 RPM	0 - 3600	
		Tach Accel Trip Delay	1 sec	1 - 60	
		Analog Output #1	RMS Current	Off, RPM 0-3600, Hottest Non-Stator RTD 0-200°C, Hottest Stator RTD 0 - 200°C, RMS Current 0 - 7500 A, % Motor Load 0 - 600 %.	
		Analog Output #1 4mA:	0	0-65535	
		Analog Output #1 20mA:	250	0-65535	
		Analog Output #2	% Motor Load	Same As Analog Input #1	
		Analog Output #2 4mA:	0	0-1000%	
		Analog Output #2 20mA:	1000	0-1000%	
		User Programmable External Inputs			
		TCB Fault	Enabled	Enabled or Disabled	
		Name Ext. Input #1	TCB Fault	User Defined, up to 15 Characters	
		TCB Fault Type	NO	Normally Open or Closed	
		TCB Fault Time Delay	1 sec	0-60 sec	
		External Input #2	Disabled	Enabled or Disabled	
		Name Ext. Input #2		User Defined, up to 15 Characters	
		External Input #2 Type	NO	Normally Open or Closed	
		External Input #2 Time Delay	0 sec	0-60 sec	
		Second Ramp	Dual Ramp	Enabled or Disabled or Dual Ramp	
		Name Ext. Input #3	Second Ramp	User Defined, up to 15 Characters	
		Second Ramp Type	NO	Normally Open or Closed	
		Second Ramp Time Delay	0 sec	0-60 sec	
		Thermostat	Enabled	Enabled or Disabled	
		Name Ext. Input #4	Thermostat	User Defined, up to 15 Characters	
		Thermostat Type	NC	Normally Open or Closed	
Thermostat Time Delay	1 sec	0-60 sec			

Chapter 8 - Commissioning and Warranty

Model #: _____

Serial #: _____

Setpoint Page	Security Level	Description	Factory Setting Default	Range	Setting
Page 7 Custom Acceleration Curve	Level 3 Password Protection	Custom Accel Curve	Disabled	Disabled, Curve A, B, or C	
		Custom Curve A			
		Curve A Voltage Level 1	25%	0-100%	
		Curve A Ramp Time 1	2 sec	1-60 sec	
		Curve A Voltage Level 2	30%	0-100%	
		Curve A Ramp Time 2	2 sec	1-60 sec	
		Curve A Voltage Level 3	37%	0-100%	
		Curve A Ramp Time 3	2 sec	1-60 sec	
		Curve A Voltage Level 4	45%	0-100%	
		Curve A Ramp Time 4	2 sec	1-60 sec	
		Curve A Voltage Level 5	55%	0-100%	
		Curve A Ramp Time 5	2 sec	1-60 sec	
		Curve A Voltage Level 6	67%	0-100%	
		Curve A Ramp Time 6	2 sec	1-60 sec	
		Curve A Voltage Level 7	82%	0-100%	
		Curve A Ramp Time 7	2 sec	1-60 sec	
		Curve A Voltage Level 8	100%	0-100%	
		Curve A Ramp Time 8	2 sec	1-60 sec	
		Curve A Current Limit	350% FLA	200-600%	
		Custom Curve B		Same Programmable Data Points and Ranges as Custom Curve A	
Custom Curve C		Same Programmable Data Points and Ranges as Custom Curve A			

Setpoint Page	Security Level	Description	Factory Setting Default	Range	Setting
Page 8 Overload Curve Configuration	Level 3 Password Protection	Basic Run Overload Curve			
		Run Curve Locked Rotor Time	O/L Class	1-30 sec, O/L Class	
		Run Locked Rotor Current	600% FLA	400-800%	
		Coast Down Timer	Disabled	1-60 Min, Disabled	
		Basic Start Overload Curve			
		Start Curve Locked Rotor Time	O/L Class	1-30 sec, O/L Class	
		Start Locked Rotor Current	600% FLA	400-800%	
		Acceleration Time Limit	30 sec	1-300 sec, Disabled	
		Number of Starts Per Hour	Disabled	1-6, Disabled	
		Time Between Starts Time	Disabled	1-60 Min, Disabled	
		Area Under Curve Protection	Disabled	Enabled or Disabled	
		Max I* ² *T Start	368 FLA	1-2500 FLA*FLA*sec	
		Current Over Curve	Disabled	Disabled, Learn, Enabled	
		Learned Start Curve Bias	10%	5-40%	
		Time for Sampling	30 sec	1-300 sec	

Chapter 8 - Commissioning and Warranty

Model #: _____
 Serial #: _____

Setpoint Page	Security Level	Description	Factory Setting Default	Range	Setting
Page 9 RTD Configuration	Level 3 Password Protection	Use NEMA Temp for RTD Values	Disabled	Enabled or Disabled	
		# of RTD Used for Stator	4	0-6	
		RTD Voting	Disabled	Enabled or Disabled	
		Stator Phase A1 Type	Off	120 OHM NI, 100 OHM NI, 100 OHM PT, 10 OHM CU	
		RTD #1 Description	Stator A1	User defined, Up to 15 Characters	
		Stator Phase A1 Alarm Level	Off	0-240C (32-464F), Off	
		Stator Phase A1 Trip Level	Off	0-240C (32-464F), Off	
		Stator Phase A2 Type	Off	Same as Stator Phase A1	
		RTD #2 Description	Stator A2	User defined, Up to 15 Characters	
		Stator Phase A2 Alarm	Off	0-240C (32-464F), Off	
		Stator Phase A2 Trip Level	Off	0-240C (32-464F), Off	
		Stator Phase B1 Type	Off	Same as Stator Phase A1	
		RTD #3 Description	Stator B1	User defined, Up to 15 Characters	
		Stator Phase B1 Alarm Level	Off	0-240C (32-464F), Off	
		Stator Phase B1 Trip Level	Off	0-240C (32-464F), Off	
		Stator Phase B2 Type	Off	Same as Stator Phase A1	
		RTD #4 Description	Stator B2	User defined, Up to 15 Characters	
		Stator Phase B2 Alarm Level	Off	0-240C (32-464F), Off	
		Stator Phase B2 Trip Level	Off	0-240C (32-464F), Off	
		Stator Phase C1 Type	Off	Same as Stator Phase A1	
		RTD #5 Description	Stator C1	User defined, Up to 15 Characters	
		Stator Phase C1 Alarm Level	Off	0-240C (32-464F), Off	
		Stator Phase C1 Trip Level	Off	0-240C (32-464F), Off	
		Stator Phase C2 Type	Off	Same as Stator Phase A1	
		RTD #6 Description	Stator C2	User defined, Up to 15 Characters	
		Stator Phase C2 Alarm Level	Off	0-240C (32-464F), Off	
		Stator Phase C2 Trip Level	Off	0-240C (32-464F), Off	
		End Bearing Type	Off	Same as Stator A1	
		RTD #7 Description	End Bearing	User defined, Up to 15 Characters	
		End Bearing Alarm Level	Off	0-240C (32-464F), Off	
		End Bearing Trip Level	Off	0-240C (32-464F), Off	
		Shaft Bearing Type	Off	Same as Stator Phase A1	
RTD #8 Description	Shaft Bearing	User defined, Up to 15 Characters			
Shaft Bearing Alarm Level	Off	0-240C (32-464F), Off			
Shaft Bearing Trip Level	Off	0-240C (32-464F), Off			
RTD #9 Type	Off	Same as Stator Phase A1			
RTD #9 Description	User defined	User defined, Up to 15 Characters			
RTD #9 Alarm Level	Off	0-240C (32-464F), Off			
RTD #9 Trip Level	Off	0-240C (32-464F), Off			

Chapter 8 - Commissioning and Warranty

Model #: _____

Serial #: _____

Setpoint Page	Security Level	Description	Factory Setting Default	Range	Setting
Page 9 RTD Configuration	Level 3 Password Protection	RTD #10 Type	Off	Same as Stator Phase A1	
		RTD #10 Description	User defined	User defined, Up to 15 Characters	
		RTD #10 Alarm Level	Off	0-240C (32-464F), Off	
		RTD #10 Trip Level	Off	0-240C (32-464F), Off	
		RTD #11 Type	Off	Same as Stator Phase A1	
		RTD #11 Description	User defined	User defined, Up to 15 Characters	
		RTD #11 Alarm Level	Off	0-240C (32-464F), Off	
		RTD #11 Trip Level	Off	0-240C (32-464F), Off	
		RTD #12 Type	Off	Same as Stator Phase A1	
		RTD #12 Description	User defined	User defined, Up to 15 Characters	
		RTD #12 Alarm Level	Off	0-240C (32-464F), Off	
		RTD #12 Trip Level	Off	0-240C (32-464F), Off	

Setpoint Page	Security Level	Description	Factory Setting Default	Range	Setting
Page 10	Level 3	Set Level 2 Password	100	000 – 999 Three Digits	
		Set Level 3 Password	1000	0000 – 9999 Four Digits	

Setpoint Page	Security Level	Description	Factory Setting Default	Range	Setting
Page 11 Communications	Level 3 Password Protection	Set Front Baud Rate	9.6 KB/sec	2.4, 4.8, 9.6, 19.2, 38.4 KB/sec	
		Set Modbus Baud Rate	9.6 KB/sec	2.4, 4.8, 9.6, 19.2, 38.4 KB/sec	
		Modbus Address Number	247	1 – 247	
		Set Access Code	1	1 – 999	
		Set Link Baud Rate	38.4 KB/sec	2.4, 4.8, 9.6, 19.2, 38.4 KB/sec	
		Remote Start/Stop	Disabled	Enabled or Disabled	

Chapter 8 - Commissioning and Warranty

Model #: _____
 Serial #: _____

Setpoint Page	Security Level	Description	Factory Setting Default	Range	Setting
Page 12 System Setpoints	Level 3 Password Protection	Default Display Screen			
		Metering Data Page #	1	Enter Metering Page (1-4)	
		Metering Data Screen #	1	Enter Metering Screen Page 1(1-10) Page 2 (1-11) Page 3 (1 - 29) Page 4 (1 - 6)	
		Alarms			
		RTD Failure Alarm	Disabled	Enabled or Disabled	
		Thermal Register Alarm	90%	Off, 40-95%	
		Thermal Alarm Delay	10 sec	1-20 sec	
		Thermal Register Setup Info			
		Cold Stall Time	O/L Class	O/L Class (5-30) or 4-40 second time delay	
		Hot Stall Time	½ O/L Class	½ O/L Class, 4-40 sec	
		Stopped Cool Down Time	30 Min	10-300 Min	
		Runing Cool Down Time	15 Min	10-300 Min	
		Relay Measured Cool Rates	Disabled	Enabled or Disabled	
		Thermal Register Minimum	15%	10-50%	
		Motor Design Ambient Temp	40C	10-90C	
		Motor Design Run Temperature	80% Max	50-100% of Motor Stator Max Temp	
		Motor Stator Max Temp	INS CLS	INS CLS, 10-240 C	
		I/B Input to Thermal Register	Enabled	Enabled Only	
		Use Calculated K or Assign	7	1-50, On	
Press Enter to Clr Thermal Register					

Setpoint Page	Security Level	Description	Factory Setting Default	Range	Setting
Page 13 Calibration & Service	FACTORY USE ONLY	Set Date and Time (DDMMYY:HHMM)	FACTORY SET; ##### ##:##		
		Enter Date (DDMMYYYY)	FACTORY SET; #####	D=1-31, M=1-12, Y=1970-2069	
		Enter Time (HH:MM)	FACTORY SET; ##:##	H=00-23, M=0-59	
		Model # Firmware REV. #	FACTORY SET; #####	Display Only, Cannot be changed	
		Press Enter to Access Factory Settings		Available to Qualified Factory Personnel	



Low Voltage Products & Systems

ABB Inc.
1206 Hatton Rd.
Wichita Falls, TX 76302
Tel. 888-385-1221
940-397-7000
Fax 940-397-7085
Web www.abb.com/lowvoltage

1SXU132172M0201 [AC 1007.1]
October, 2003