



Type KDTG Distance And Timer Relay

Effective: June 1985
Supersedes I.L. 41-497C Dated May 1975

⊙ Denotes Changed Since Previous Issue

CAUTION

Before putting protective relays into service, remove all blocking which may have been inserted for the purpose of securing the parts during shipment, make sure that all moving parts operate freely, inspect the contacts to see that they are clean and close properly, and operate the relay to check the settings and electrical connections.

APPLICATION

Type KDTG relay is a polyphase compensator type distance relay with a static two zone timer. The distance unit responds to phase-to-phase faults, two-phase-to-ground, and single phase-to-ground faults. This unit is identical in its response to the phase-to-phase unit of the KD-type distance relays and does not operate on three-phase faults. The KDTG relay is used with the KDXG ground reactance relays for directional supervision for high speed clearing of single phase-to-ground faults in the first zone of protection and to provide accurate time delayed switching of the reactance units to second and third zone settings. This relay is not subject to wrong directional sensing due to mutual induction on parallel lines. Zero sequence polarizing and operating quantities are not required for the KDTG relay.

Where relay current for a ground fault within the reach of the relay is less than approximately 3 amperes or where a third zone reach in excess of approximately 10 ohms is required, the KRT relay should be used instead of the KDTG.

CONSTRUCTION AND APPLICATION

The KDTG relay consists of a single cylinder type unit, two single air gap compensators, two

autotransformers, two timing circuits, three telephone relays, one voltage regulator, 3 blocking diodes, one pulsing transformer, three operational Zone indicators, and one contactor switch.

COMPENSATOR

The compensators which are designated TAB and TBC are three-winding air gap transformers. There are two primary current windings. Each current winding has seven taps which terminate at the tap block. They are marked 1.5, 2.0, 2.50, 3.50, 5.0, 7.0 and 10.0. Current flowing through the primary coil provides an MMF which produces magnetic lines of flux in the core.

A voltage is induced in the secondary winding which is proportional to the primary tap and current magnitude. This proportionality is established by the cross sectional area of the laminated steel core, the length of an air gap which is located in the center of the coil, and the tightness of the laminations. All of these factors which influence the secondary voltage proportionality have been precisely set at the factory. The clamps which hold the laminations should not be disturbed by either tightening or loosening the clamp screws.

The secondary winding is connected subtractively in series with the relay terminal voltage. Thus a voltage which is proportional to the phase current is subtracted vectorially from the relay terminal voltage. The secondary winding loaded with an adjustable resistor and provides a means of adjusting the phase angle relation between primary current and the induced secondary voltage. The factory setting is for maximum torque angle of 75° current lagging the voltage.

All possible contingencies which may arise during installation, operation or maintenance, and all details and variations of this equipment do not purport to be covered by these instructions. If further information is desired by purchaser regarding this particular installation, operation of maintenance of this equipment, the local ABB representative should be contacted.

AUTOTRANSFORMER

The autotransformer has three taps on its main winding, S, which are numbered 1, 2, and 3 on the tap block.

The autotransformer makes it possible to expand the basic range ($T = 1.5$ to 10.0 ohms) by a multiplier of S. Therefore, any relay ohm setting can be made within ± 15 percent from 1.5 ohms to 30 ohms by combining the compensator taps TAB, and TBC with the autotransformer taps, SA and SC.

TRIPPING UNIT

The device which acts to initiate tripping is a four-pole cylinder unit which is connected open delta and operates as a three-phase induction motor. Contact-closing torque is produced by the unit when the voltage applied to its terminals has a negative-phase sequence. Closing torque for the relay forces the moving contact to the left hand side as viewed from the front of the relay. Contact-opening torque is produced when positive-phase sequence voltage is applied. Hence, the cylinder unit has restraint or operating torque as determined by the phase sequence of the voltages applied to its terminals.

Mechanically, the cylinder unit is composed of three basic components: a die-cast aluminum frame and electromagnet, a moving element assembly, and a molded bridge.

The frame serves as the mounting structure for the magnetic core. The magnetic core which houses the lower pin bearing is secured to the frame by a spring and snap ring. This is an adjustable core which has a .020 inch flat on one side and is held in its adjusted position by the clamping action of two compressed springs. The bearing can be replaced, if necessary, without having to remove the magnetic core from the frame.

The electromagnet has two series-connected coils mounted diametrically opposite one another to excite each set of poles. Locating pins on the electromagnet are used to accurately position the lower pin bearing, which is mounted on the frame, with respect to the upper pin bearing, which is threaded into the bridge. The electromagnet is permanently secured to the frame and cannot be separated from the frame.

The moving element assembly consists of a spiral spring, contact carrying member, and an aluminum cylinder assembled to a molded hub which holds the shaft. The hub to which the moving-contact arm is clamped has a wedge-and-cam construction, to provide low-bounce contact action. A casual inspection of the assembly might lead one to think that the contact arm bracket does not clamp on the hub as tightly as it should. However, this adjustment is accurately made at the factory and is locked in place with a locknut and should not be changed.

Optimum contact action is obtained when a force of 7 to 9 grams pressure applied to the face of the moving contact will make the arm slip one-fourth of its total free travel. Free travel is the angle through which the hub will slip from the condition of reset to the point where the clamp projection begins to ride up on the wedge. The free travel can vary between 15° to 20° .

The shaft has removable top and bottom jewel bearing. The shaft rides between the bottom pin bearing and the upper pin bearing which is adjusted to .025 inch from the top of the shaft bearing. The cylinder rotates in an air gap formed by the electromagnet and the magnetic core.

The bridge is secured to the electromagnet and the frame by two mounting screws. In addition to holding the upper pin bearing, the bridge is used for mounting the adjustable stationary contact housing. This stationary contact has .002 to .006 inch follow which is set at the factory by means of the adjusting screw. After the adjustment is made the screw is sealed in position with a material which flows around the threads and then solidifies. The stationary contact housing is held in position by a spring type clamp. The spring adjuster is located on the underside of the bridge and is attached to the moving contact arm by a spiral spring. The spring adjuster is also held in place by a spring type clamp.

When the contacts close, the electrical connection is made through the stationary contact housing clamp, to the moving contact, through the spiral spring out to the spring adjuster clamp.

TIMING CIRCUITS

Each of the two timing units is an encapsulated module that consists of an R-C timing circuit, a

zener diode for voltage sensing, and a transistorized amplifying circuit.

VOLTAGE REGULATOR

Voltage regulator is a silicon zener type diode. It provides a constant voltage reference for timing circuits.

TELEPHONE RELAYS

The telephone relay units T1, TA2, TA3, are fast operate types. In these relays an electromagnet attracts a right angle iron bracket which in turn operates a set of make and break contacts.

PULSING TRANSFORMER

Pulsing transformer is designed to operate on the impulse from the initial build up of current in the tripping circuit. The low resistance primary winding of the transformer is connected in series with tripping circuit. The secondary of transformer is connected to the operation indicators for Zone 1, 2, and 3. Selection of the proper operation indicator is controlled by timer contacts TA2, and TA3.

BLOCKING DIODES

Diode D1, is a medium power silicon type rectifier. Diode D1 is connected across the coil of the T1 relay. Its function is to provide a path for dissipation of the transient energy released by the coil after any of the contacts controlling its operation opens. Diodes D2 and D3 function in a similar manner across the telephone relays T2X and T3X, located in the KDXG-relays. Diodes D2 and D3 are zener type diodes.

OPERATION INDICATOR UNIT (OI)

Three operation indicator units are used to indicate in which zone of protection the fault occurred. Z1 indicator is located in the upper left-hand corner. The operation indicator unit is a small d-c operated clapper type device. A magnetic armature is attracted to the magnetic core upon energization of the unit. During this operation, two fingers on the armature deflect a spring located on the front of the unit which allows the operation indicator target to drop. The target is reset from the outside of the case by a push rod located at the bottom of the cover.

CONTACT SWITCH UNIT (CS)

The d-c contactor switch is a small clapper-type device similar in appearance to the operation indicators and is located in the upper right hand corner. A magnetic armature, to which leaf-spring mounted contacts are attached, is attracted to the magnetic core upon energization of the switch. When the switch closes, the moving contacts bridge two stationary contacts, completing the trip circuit to seal in around the contacts of the operating units in the system and to relieve them from carrying all of the current. The front spring provides restraint for the armature and thus controls the pickup of the switch.

OPERATION

The relay is connected and applied to the system as shown in Fig. 2. The distance unit closes its contacts to permit tripping for ground faults in the direction of the protected line and opens its contacts to block tripping for ground faults located behind the relay and for all phase faults not involving ground. Upon occurrence of a single line-to-ground fault on the protected line, the ratio discriminator in the KDXG relay (RD) and the distance unit (Z) close their contacts to operate the T1 telephone relay which starts the timer operation. If the single phase-to-ground fault is located in Zone 1, the reactance unit operation completes the tripping circuit and the buildup of tripping current through the primary of the pulsing transformer will operate the operation indicator for Zone 1. If the fault is located in the second or third zone, after preset time delays, the telephone relays, TA2 and TA3 will switch the reach of the reactance unit to a Z2-reach and later to a Z3-reach respectively. Simultaneously with switching the reach TA2 and TA3 set up the Zone 2 and Zone 3 operation indicators for proper indication.

TIME UNIT OPERATION

There are two RC timing circuits, one for each zone.

The RC timing circuit in Fig. 3 delivers an increasing voltage to the sensing zener diode (DZ2). DZ2 breaks down at approximately 63% of the reference voltage which is supplied by the voltage regulating zener diode DZ, the rate of voltage rise is determined by the resistance (RH2 or RH3) in

series with timing capacitor. Therefore, the rheostat setting of T2 or T3 directly determines the total time delay for Z2 and Z3 respectively.

When capacitor C charges to the voltage value E, DZ2 breaks down to provide base drive for transistor TR₂ causing it to conduct. Emitter current of TR₂ provides base drive for transistor TR₁. Transistor TR₁ conducts, energizing the output relay. Resetting of the timer is initiated by the resetting of either the ratio discriminator or distance unit.

CHARACTERISTICS

The KDTG relay is available in 48, 125, and 250 Vdc rating.

DISTANCE UNIT (Z)

The distance unit of the KDTG relay is:

1. Insensitive to line energizing transients and unequal pole closing. The unit does not respond to Zero sequence quantities and is restrained by rated voltage during this non-fault period.
2. Inherently immune to incorrect polarization resulting from mutual induction.
3. Does not require Zero sequence current flow for operation and thus is applicable for transformer terminations or taps where the high side winding is delta connected.
4. Either open delta potential or low side voltage from the other side of Wye-Delta bank can be utilized.
5. It responds to phase-to-phase, two-phase-to-ground and single phase-to-ground faults. The ratio discriminator in the KDXG relays prevents operation of the relay on phase-to-phase and two-phase-to-ground faults.

TAP PLATE MARKINGS

T_A, T_B, T_C						
1.5	2.0	2.5	3.5	5.0	7.0	10.0
S_A, S_C						
1	2	3				

BURDEN DATA

CURRENT BURDEN TABLE

Three-Phase Current = 5 $\angle -75^\circ$ Amperes
 Potential Circuit $V_{In} = 69 \angle 0^\circ$

Tap Setting	Phase 1 and					
	Phase 3			Phase 2		
	VA	VARS	Watts	VA	VARS	Watts
1.5	.703	.540	.451	.882	.804	.358
2.0	.833	.640	.535	1.03	1.00	.249
2.5	.885	.699	.547	1.24	1.21	.257
3.5	1.16	.983	.613	1.70	1.68	.207
5.0	1.67	1.48	.758	2.47	2.45	.302
7.0	2.40	2.18	1.01	3.66	3.62	.446
10.0	3.63	3.30	1.53	5.67	5.62	.590

POTENTIAL BURDEN

$V_{In} = 69 \angle 0^\circ$ Volts
 $I_A = I_B = I_C = 5 \angle 0^\circ$ Amperes

	Phase A	Phase B	Phase C
S = 1	6.0 VA	9.7 VA	5.1 VA
S = 2	1.5 VA	2.4 VA	1.25 VA
S = 3	.70 VA	1.2 VA	.65 VA

TIMER UNIT

Timer Delay Range

Zone 2: 0.1 sec. – 1.0 sec.
 Zone 3: 0.5 sec. – 3.0 sec.

Reset Time

TA2 and TA3 Dropout Time. 0.1 sec. or less

TI – Drop Out Time 0.06 sec. or less

Timing Capacitor. Discharges to less than 1% of full voltage in 0.015 sec.

Battery Drain

	48 Vdc	125 Vdc	250 Vdc
Non-operating Condition	0	0	0
Operating Condition			
Timing Circuit and			
DZ1	53MA	48MA	35MA
T1	64MA	64MA	64MA
TXZ3	117MA	117MA	117MA

ACCURACY

Overall accuracy of the timer depends upon the repetition rate of consecutive timings, the supply voltage variation, and ambient temperature changes.

1. Nominal Setting

The first time delay, as measured with the test circuit shown in Fig. 4 taken at 25°C, and rated voltage (48, 125, or 250 Vdc), will be within ±3%.

2. Consecutive Timings

If consecutive time checks are made at any given setting, the readings decrease. This change of time delay is due to the "voltage recovery" of the timing capacitor. Voltage recovery is a characteristic which all capacitors possess; it has been minimized by the selection of the timing capacitor in the module. The amount of change in time delay depends upon the pause, or duration of capacitor discharge between timings. If a pause of at least 3 seconds is observed between readings, the timing will repeat consistently, so that the total spread between the highest and lowest readings will be no more than 2% of the setting. If timings are repeated, the decrease in time delays will be between 3% and 4% in most cases. In no case will this decrease be more than 5% of the setting.

3. Supply Voltage

Changes on supply voltage, between 80% and 110% of nominal, cause time delay variations of no more than ±5 milliseconds for settings of .5 seconds or less, and no more than ±1% for settings above .5 seconds.

4. Ambient Temperature

Changes in ambient temperature cause changes in time delay. This variation in time delay is a direct function of capacitance change with temperature. Typical variation of time delay with temperature is shown in Fig. 5.

CHARACTERISTICS

The characteristics of various elements of the timer are as follows:

	48 Vdc	125 Vdc	250 Vdc
TA3 and TA2			
Relay Units	2000 ohm	2000 ohm	2000 ohm
TI Relay Unit	750 ohm	750 ohm	750 ohm
RT Resistor	350 ohm	2000 ohm	6300 ohm
RT1 Resistor	0 ohm	1180 ohm	3000 ohm
DZ1 Zener Diode	30 volts breakdown 10 watt		
RH2 Rheostat	Adjustable 0-40,000 ohms		
RH3 Rheostat	Adjustable 0-100,000 ohms		

BLOCKING DIODES D1, D2, D3

The diode D1 is type 1N539. It is a low power silicon rectifier. It has .75 amperes maximum current rating at 50°C, maximum reverse current at rated peak inverse voltage of 300 volts is 10 micro-amperes at 50°C. Forward voltage drop at 1 amp instantaneous at 25°C volts is less than 1 volt. The diodes D2 and D3 are zener type 1N3051. 250 Vdc relays have 2 1N3051 Diodes connected in series for every diode used on 48 and 125 Vdc rated relays.

TRIPPING CIRCUIT

The contactor switch has a nominal rating of 1 ampere. The burden of the tripping circuit consists of the d-c resistance of the contactor switch and the primary of the pulsing transformer, and is equal to .64 ohm d-c resistance. Since operation of the pulsing transformer depends on the rate of change of current which depends on inductance of the tripping path, it is recommended that the inductance of the tripping path for circuits with 4 amperes of final current should not exceed 2.8 Henrys. For larger final currents, the inductance limiting value is much higher. Usually the inductance of a typical tripping coil varies between

.028 and .250 Henrys. The tripping circuit of the KDTG relay should not be shunted by less than 100 ohms of d-c resistance.

SETTINGS

DISTANCE UNIT

The distance unit requires setting. For each compensator (T_A , T_B , T_C) and each autotransformer (S_A , S_C). All of these settings are made with taps on the tap plate.

COMPENSATOR (T_A , T_B , T_C)

Each set of compensator taps terminate in inserts which are grouped on a socket and form approximately three quarters of a circle around a center insert which is the common connection for all of the taps. Electrical connections between common insert and tap inserts are made with a link that is held in place with two connector screws, one in the common and one in the tap. There are two T_B settings to be made since phase B current is passed through two compensators. A compensator tap setting is made by loosening the connector screw in the center.

Remove the connector screw in the tap end of the link, swing the link around until it is in position over the insert for the desired tap setting, replace the connector screw to bind the link to this insert, and retighten the connector screw in the center. Since the link and connector screws carry operating current, be sure that the screws are turned to bind snugly.

AUTOTRANSFORMER PRIMARY (S_A AND S_C)

Primary tap connections are made through a single lead for each transformer. The lead comes out of the tap plate through a small hole located just below or above the taps and is held in place on the tap by a connector screw.

An "S" setting is made by removing the connector screw, placing the connector in position over the insert of the desired setting, replacing and tightening the connector screw. The connector should never make electrical contact with more than one tap at a time.

SETTING CALCULATIONS

The recommended setting for the relay is 30 ohms for maximum sensitivity. To make this setting compensators T_A , T_B (two settings), and T_C are set for $T = 10$ and S_A and S_C are set for $S = 3$. Make sure 30 ohms is larger than three times the Zone 3 reactance unit setting of the KDXG relay. If any other setting is desired it should be made equal to at least 3 times the positive sequence impedance of the third Zone setting of the reactance unit in the KDXG relay. Once the desired setting $Z = 3Z_{13}$ is established where $Z_{13} =$ positive sequence impedance of Zone 3 setting of the KDXG relay.

Use the following procedure:

Step 1: Select the lowest S which gives a product of $10S$ greater than Z as established above.

Step 2: Select a T = setting that is equal to $\frac{Z}{S}$ or the next highest value.

For Example:

Refer to KDXG I.L. 41-496 page 14 where Zone 3 positive sequence reactance $X_{13} = 2.58$ ohms, hence for 75°-line $Z_{13} = \frac{2.58}{\sin 75^\circ} = 2.66$ ohms.

The desired distance unit setting $Z = 3Z_{13} = (3)(2.66) = 7.98$ ohms following the procedure outlined above.

Choice A: Set relay for $S = 3$ $T = 10$ ohms for maximum sensitivity or

Choice B: This setting is made if the Choice A is unacceptable for special applications. Use procedure as outlined above starting with Step 1.

Step 1: Since $Z = 7.98$ ohms $S = 1$ gives product $10S = 10$ greater than 7.98 ohms.

Step 2: T-setting is selected as $\frac{Z}{S} = \frac{7.8}{1} = 7.8$ and the next higher setting is 10 hence, relay is set at $S_A = S_C = 1$ and $T_A = T_B = T_C = 10$.

TIMER

Proper time delay is selected by turning the knobs of rheostats RH2 and RH3 to the desired setting. Zone 2 time should always be set less than Zone 3 time. An operation of Z3 prior to Z2 will result in the autotransformer and TXZ3 switching relay contacts in the KDXG relays being momentarily overloaded. This will shorten the life of both.

INSTALLATION

The relays should be mounted on switchboard panels or their equivalent in a location free from moisture. Mount the relay vertically by means of the four mounting holes on the flange for semi-flush mounting or by means of the rear mounting stud or studs for projection mounting. Either a mounting stud or the mounting screws for steel panel mounting. The terminal studs may be easily removed or inserted by locking two nuts on the stud and then turning the proper nut with a wrench.

For detailed FT Case Information, refer to I.L. 41-076.

ADJUSTMENT AND MAINTENANCE

The proper adjustments to insure correct operation of this relay has been made at the factory and should not be disturbed after receipt by the customer. Do not remove the knobs on the RH2 and RH3 rheostats unless the rheostats are to be replaced as this will upset the relay calibration.

ACCEPTANCE TESTS

DISTANCE UNITS

Check the electrical response of the relay by using the test connections in Fig. 6. Set T_A, both T_B, and T_C for 10.0 S, S_A and S_C for 3.

- A. Use connection for Test No. 5.
- B. Adjust the voltage between PH.1 and 1F and between PH.2 and 2F for 15 volts each so that the resultant voltage V_{1F2F} equals 90 volts ($120 - 15 - 15 = 90V$).

- C. The current required to make the contacts close for the phase-to-phase (top) unit should be between 1.45 and 1.55 amperes at an angle of 75° current lag.

- D. Repeat C while using connections for Test No. 6 and Test No. 7.

TIMER UNIT

A timing check at various settings is recommended using test circuit of Fig. 4.

CONTACTOR SWITCH

Energize the contactor switch between terminals 11 and 10 with sufficient current to pick up the contactor switch. It should occur between the 1.0 and 1.2 amp D-C.

OPERATION INDICATOR TEST

Energize the pulsing transformer between terminals 11 and 10 through a switch with 0.7 amperes of D-C current suddenly applied. The operation indicator marked "1" should operate after closing the switch. It will not operate when current is increased gradually. Close armature of TA2 relay manually, and operate reclose switch, again operation indicator marked "2" should operate. Operate TA2 and TA3 relay closed – reclose switch again operation indicator marked "3" should operate.

ROUTINE MAINTENANCE

All contacts should be cleaned periodically. A contact burnisher S#182A836H01 is recommended for this purpose. The use of abrasive material for cleaning contacts is not recommended, because of the danger of embedding small particles in the face of the soft silver and thus impairing the contact.

CALIBRATION

Use the following procedure for calibrating the relay if the relay has been taken apart for repairs or the adjustments have been disturbed. This procedure should not be used unless it is apparent that the relay is not in proper working order (See "Acceptance Check").

INSULATION TEST

1. Place jumpers across all diodes.
2. Connect terminals into following groups.
 - Group 1 – 1, 10, 11, 20
 - Group 2 – 18, 19
 - Group 3 – 2, 3
 - Group 4 – 7, 8, 9
 - Group 5 – 12, 13, 14, 15, 16, 17
 - Group 6 – 6, 19
3. Apply 1000 volts, 60 cps for one second from Group 5 to Group 6. Apply 2000 volts a-c, 60 cps for one second from all groups, and from group to group, as noted above.

DISTANCE UNIT

Use the following procedure for calibrating the relay if the relay has been taken apart for repairs or the adjustments disturbed.

Connect the relay for testing as shown in Fig. 6. The four-pole-double-throw switch shown in the test circuit selects the type of voltage condition, for a phase-to-phase or a three-phase fault, that will be applied to the relay voltage terminals. The rotary switch switches the fault voltage to various terminals and thereby simulates any combination of phase-to-phase faults without the tester having to change connections or readjust the phase shifter and variable autotransformers.

For best results in checking calibration, the relay should be allowed to warm up for approximately one hour at rated voltage. However, a cold relay check to within two percent of the warm relay.

TRIPPING UNITS

With the stationary contact open so that the moving contact cannot touch, set the moving contact spring adjuster so that the contact floats freely in the gap. Make sure that there is no friction which prevents free movement of the cylinder and contact arm.

The upper pin bearing should be screwed down until there is approximately .025 inch (one complete turn of the screw) between it and the top

of the shaft bearing. The upper pin bearing should then be securely locked in position with the lock nut. The lower bearing position is fixed and cannot be adjusted.

AUTOTRANSFORMER CHECK

Autotransformers may be checked for turns ratio and polarity by using the No. 2 test connections of Fig. 6, and the procedure outlined below. (No current applied.)

Set S_A and S_C on tap number 3. Adjust the voltages V_{1F2F} and V_{2F3F} for 90 volts. Measure the voltage from terminal 8 to the #1 tap of S_A . It should be 30 volts. From 8 to the #2 tap of S_A should be 60 volts. The voltage should read 30 volts from 8 to $S_C = 1$ and 60 volts from 8 to $S_C = 2$.

DISTANCE UNIT SETTINGS

Check to see that the taps on front of the tap block are set as follows:

- ★ T_A , T_B , and T_C set on 7.0 (Tap T_B is set twice)
- S_A , and S_C set on 1

SINGLE PHASE TEST

1. Set R_{AC} – Resistor (second from the bottom – rear view, next to subbase) so that the adjustable band is in the center of the resistor. (Use caution in setting this resistor, resistor wire is fine.)
2. Open circuit R_{2C} – Resistor (bottom – rear view) by removing leads going to the adjustable band.
3. Repeat the same for R_{2A} – resistor. (second from bottom – rear view)
4. Connect terminals “7” and “8” together. Apply rated A-C voltage (120 volts) between terminals “8” and “9”. Adjust core until contact floats in the middle of the contact gap.
5. Connect terminals 8 and 9 together and apply rated A-C voltage between terminals 7 and 8 and adjust core until the contact arm floats or is restrained only, slight core adjustment

should be needed to do that. If this is not possible, rotate core 180° and adjust.

6. Connect terminals "7" and "9" together. Apply rated A-C voltage to terminals 7 and 8. Adjust R_{AC} until contact just floats.
7. Reconnect R_{2A} and R_{2C} resistors. R_{2A} and R_{2C} resistor should measure approximately 8.5 for 60 HZ and 11K for 50 HZ relays.

MAXIMUM TORQUE ANGLE ADJUSTMENT (FIG. 6)

1. Use the No. 2 Test switch position and lead connections. This connection is for checking and adjusting the maximum torque angle of the T_{AB} compensator.
2. Adjust the voltage V_{1F2F} and V_{2F3F} for 52 volts with Brush No. 1 and Brush No. 2 respectively.
3. Adjust the current to 8.5 amperes and rotate the phase shifter to find two angles, θ_1 and θ_2 , at which the top unit contacts just close. The maximum torque angle θ for the phase-to-phase unit then is $\frac{(\theta_1 + \theta_2 - 30)}{2}$ degrees. Adjust R_{2A} until maximum torque θ is 75° (± 30).
4. Use No. 4 Test Connections and repeat above procedure to check and adjust the angle of T_{BC} compensator. For 75° maximum torque angle. This adjustment is made with R_{2C} resistor (bottom resistor - rear view), set close to maximum.
5. Recheck part 3, if necessary readjust R_{2A}.
6. Recheck part 4 if part 5 required a readjustment.

CONTACT ADJUSTMENT

With moving-contact arm against right-hand backstop, screw the stationary contact in until it just touches the moving contact. (Check for contact by using an indicator lamp.) Then back the left-hand contact out two-thirds (2/3) of one turn to give 0.93-inch gap between contacts.

IMPEDANCE CURVE CHECK

Using the connections for Tests Nos. 5, 6 and 7, set the phase shifter so that the current lags voltage by θ° . The current required to trip the phase-to-phase unit should be within the limits specified for each of the voltages. Note that for distance unit the impedance measured by the relay is $Z_R = \frac{V_{L-L}}{2I_L}$ where V_{L-L} is phase-to-phase fault voltage and I_L is phase current.

Test No.	Volts	Amperes ($\theta = 75^\circ$)	
	V _{1F2F}	I _{min}	I _{max}
5, 6 and 7	2.0	.130	*.157
	5.0	.334	.375
	30.0	2.08	2.20
	70.0	4.85	5.16

*Perform test 7 first, and readjust R_{AC} to bring within limits.

SPRING RESTRAINT (FIG. 6)

1. Use Test No. 1 connections except reverse the voltage phase sequence by interchanging the Brush connections so that Brush 1 is connected to 3F and Brush 2 is connected to 1F.
2. Adjust the voltage V_{1F2F} and V_{2F3F} for 4.5 volts each with Brush No. 2 and Brush No. 1 respectively. Position the moving-contact spring adjuster so that the contact just floats and then return the circuit connections to normal with Brush 1 to 1F and Brush 2 to 3F.

CS TEST (RH TOP)

Check contact gap. It should be 5/64" + 0-1/64". Pickup must not be less than 1.0 amp d-c nor greater than 1.2 amperes suddenly applied. To increase pickup current, bend the springs out, or away from the cover. To decrease the pickup current, bend the springs toward the cover.

OPERATION INDICATOR TEST

1. Energize CS with 0.5 amp d-c current through a S.P.S.T. switch. After switch is closed unit with target marked "1" should operate. To

increase or decrease O.I. pickup, adjust the spring the same way as for C.S. described above. Repeat the pickup check of the indicator five times.

2. Block telephone relay TA2 closed. Energize CS again through the switch. The unit marked "2" should operate. Adjust spring if necessary for correct pickup.
3. Block telephone relays TA2 and TA3 closed. Energize CS again through the switch. The unit marked "3" should operate. Adjust spring if necessary for correct pickup.

It should be noted that if polarity of the d-c supply has been reversed, on the first try operation indicator may operate on much lower current. Hence, operate the operational indicators several times before making final adjustment. The same may be true if the operational indicator has not been operated for a long time -- on the first try it may pickup at much lower current. Hence, try pickup several times.

TIMER UNITS

Troubleshooting Procedures

Use the following procedure to locate the source of trouble if the timer is not operating properly.

1. Apply rated voltage between relay terminals 2 and 3 and check T1 contact operation.
2. Check reference voltage circuit. This is done by measuring voltage across zener diode DZ1 mounted on a large metal bracket behind operation indicator marked "1". This voltage should be zero before T1 operates, and between 27 and 32 volts d-c after T1 has operated.
3. Check rheostats RH1 and RH2, and TA2 and TA3 relays with an ohmmeter. The RH-2 should measure from 0 to 40,000 ohms and the RH-3 should measure 0-100,000 ohms.
4. If the above checks do not determine the source of trouble, either the wiring or the module, M, is faulty.

CALIBRATION

Use the following procedure for calibrating the timer if the relay adjustments have been disturbed. This procedure should not be used until it is apparent that the timer is not in proper working order. Before calibrating, follow the Troubleshooting Procedure to locate the source of trouble.

1. Telephone Relay Adjustment

Adjust the armature gap on the three telephone type relays to be approximately .004" with the armature closed. This is done with the armature set-screw and lock-nut. Also, adjust contact leaf springs to obtain at least .015" gap on all contacts and at least .010" follow on all normally open contacts and at least .005" follow on all normally closed contacts.

2. Rheostat Knob Adjustment, Same Scale Plate

If it is necessary to replace the RH2 or RH3 rheostats the relay may be recalibrated with the same scale plate. This is done by rotating the shaft, without knob, until a 1.0 second delay is measured for RH2 or a .5 second delay is measured for RH3. Then, align the knob for this delay and tighten the knob set-screw securely. There should be a pause of several seconds between readings for all time delays above .5 seconds. See section under Accuracy for discussion of this.

3. Scale Plate Calibration, New Scale Plate

If it is necessary to replace the silicon power regulator (DZ1), or the modules (M), the relay should be recalibrated with a new scale plate. The first step should be to insure that the knob is approximately vertical for the midscale time delay (.550 seconds for T2 and 1.75 for T3). This will locate the calibration lines symmetrically around the scale plate. After centering and securely locking the knob on the rheostat shaft, new calibration lines may be marked on the scale plate. When scribing calibration lines for delays above .5 seconds, there should be a pause of at least 3 seconds between readings. See section under Accuracy for discussion of this.

BREAKDOWN VOLTAGE FOR 48/125 Vdc RELAYS

Apply D-C voltage source with 10,000 ohm resistor in series with terminals 4 and 6 with positive on 4. Measure the leakage current with a d-c milliammeter. Start with 100 volts d-c and increase voltage until current exceeds 0.25 milliamps and starts to increase rapidly. Do not exceed 3 MA. The voltage at which current exceeds .25 MA should be between 60 and 240 volts. Repeat the same test for terminals 5 and 6, except connect positive to terminal 5.

LEAKAGE CURRENT FOR 250 Vdc RELAYS

The same test as above except breakdown voltage should be between 320 and 480 volts.

RENEWAL PARTS

Repair work can be done most satisfactorily at the factory. However, interchangeable parts can be furnished to customers who are equipped for doing repair work. When ordering parts, always give the complete nameplate data.

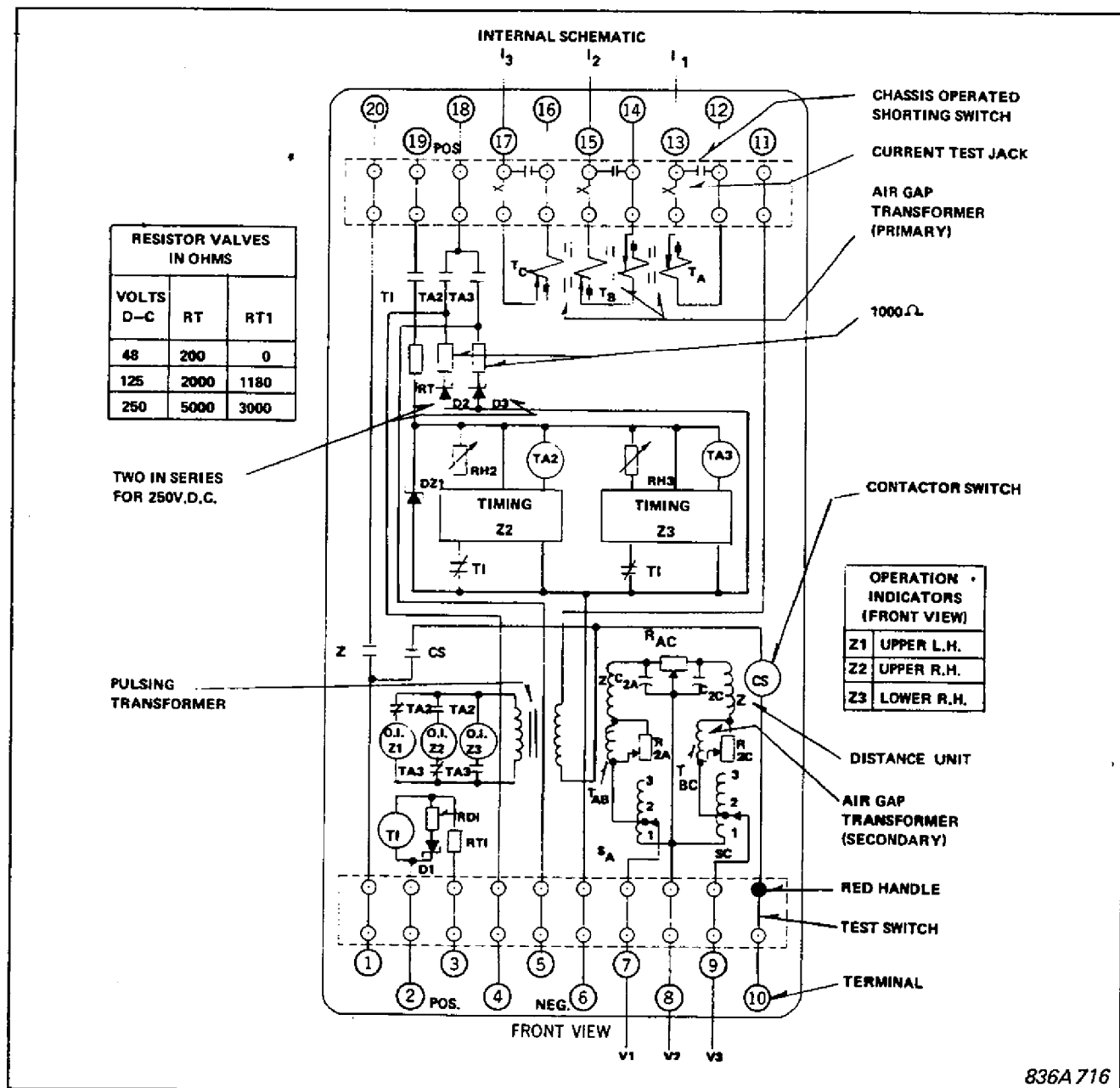
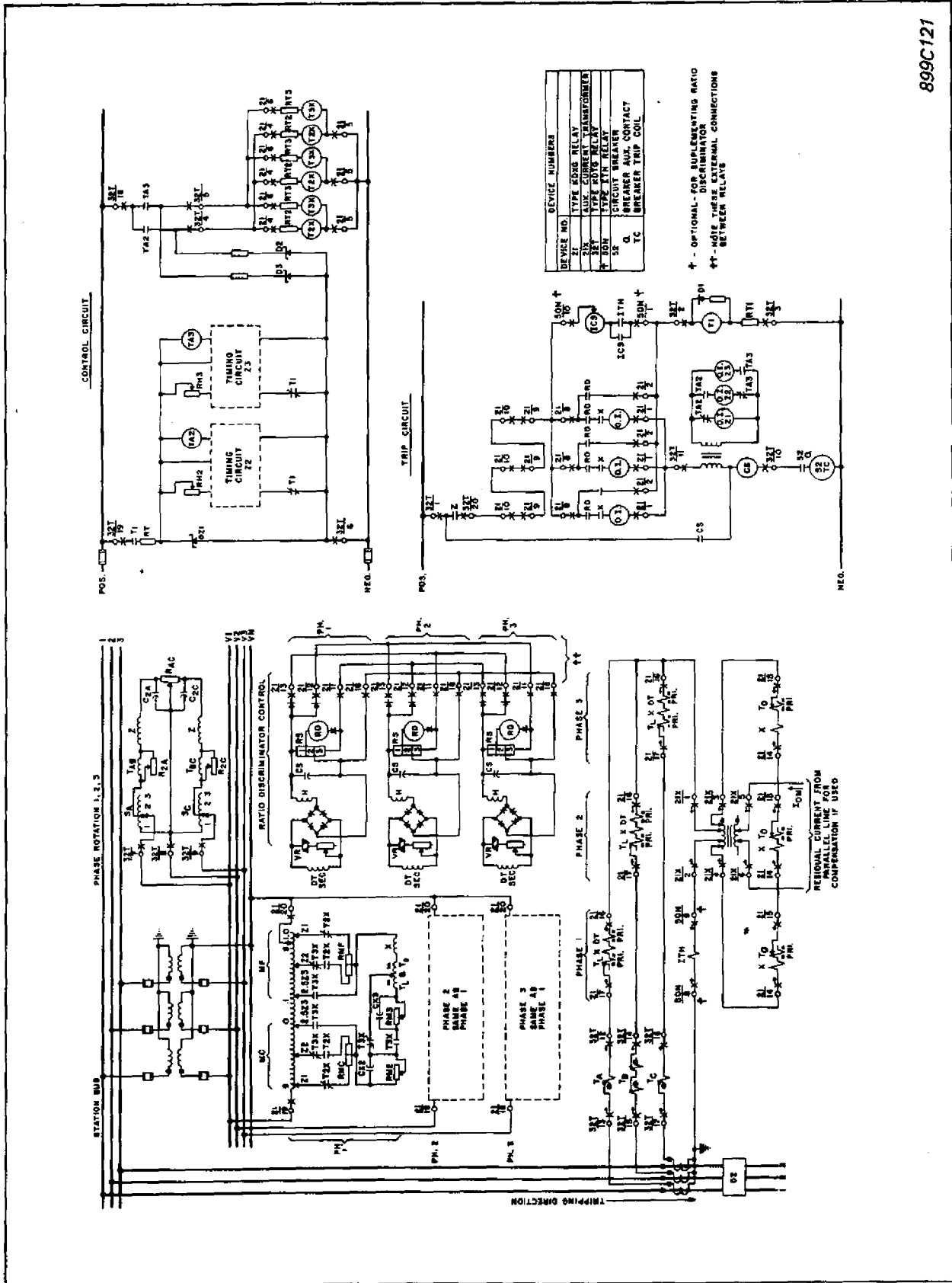

Fig. 1. Internal Schematic of the Type KDTG Relay.

836A 716



899C121

Fig. 2. External Schematic of the Type KDTG Relay.

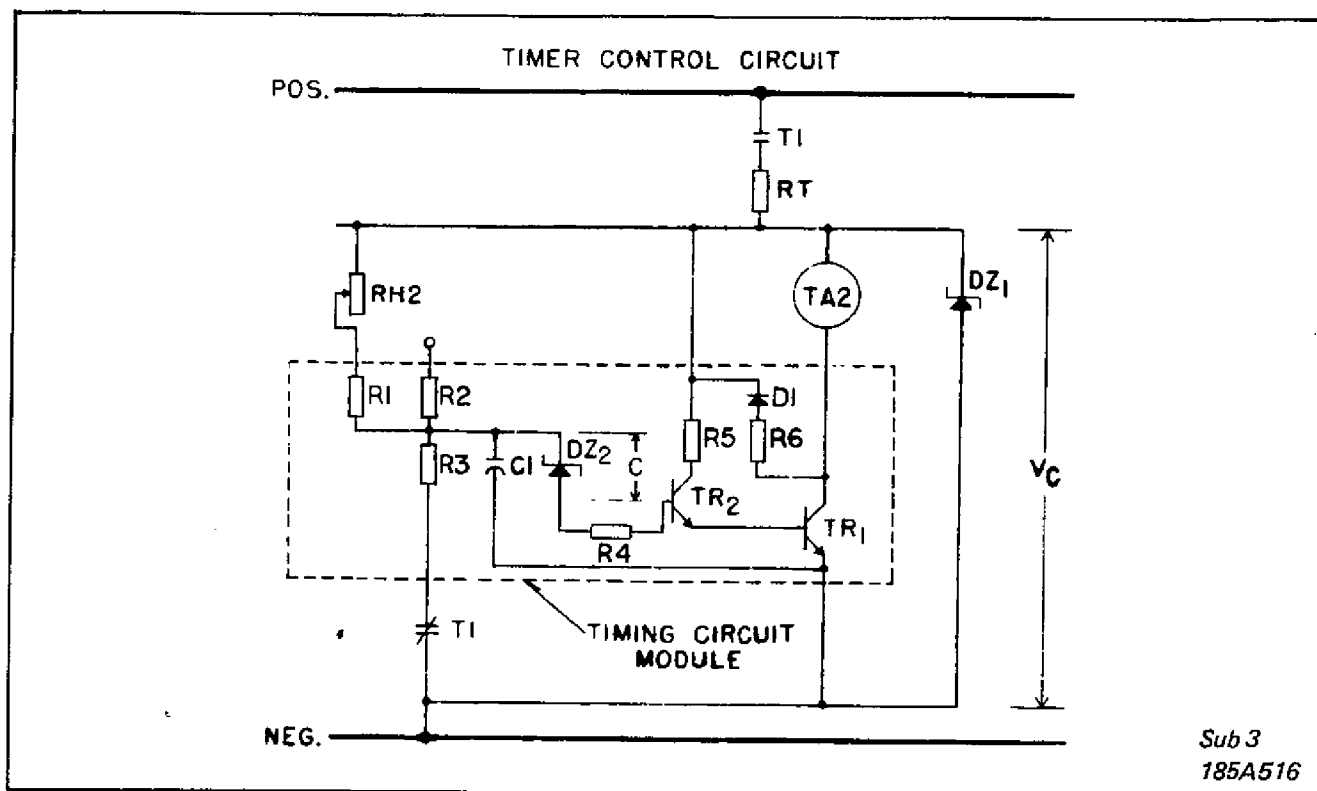

Fig. 3. Module Schematic of the Type KDTG Relay.

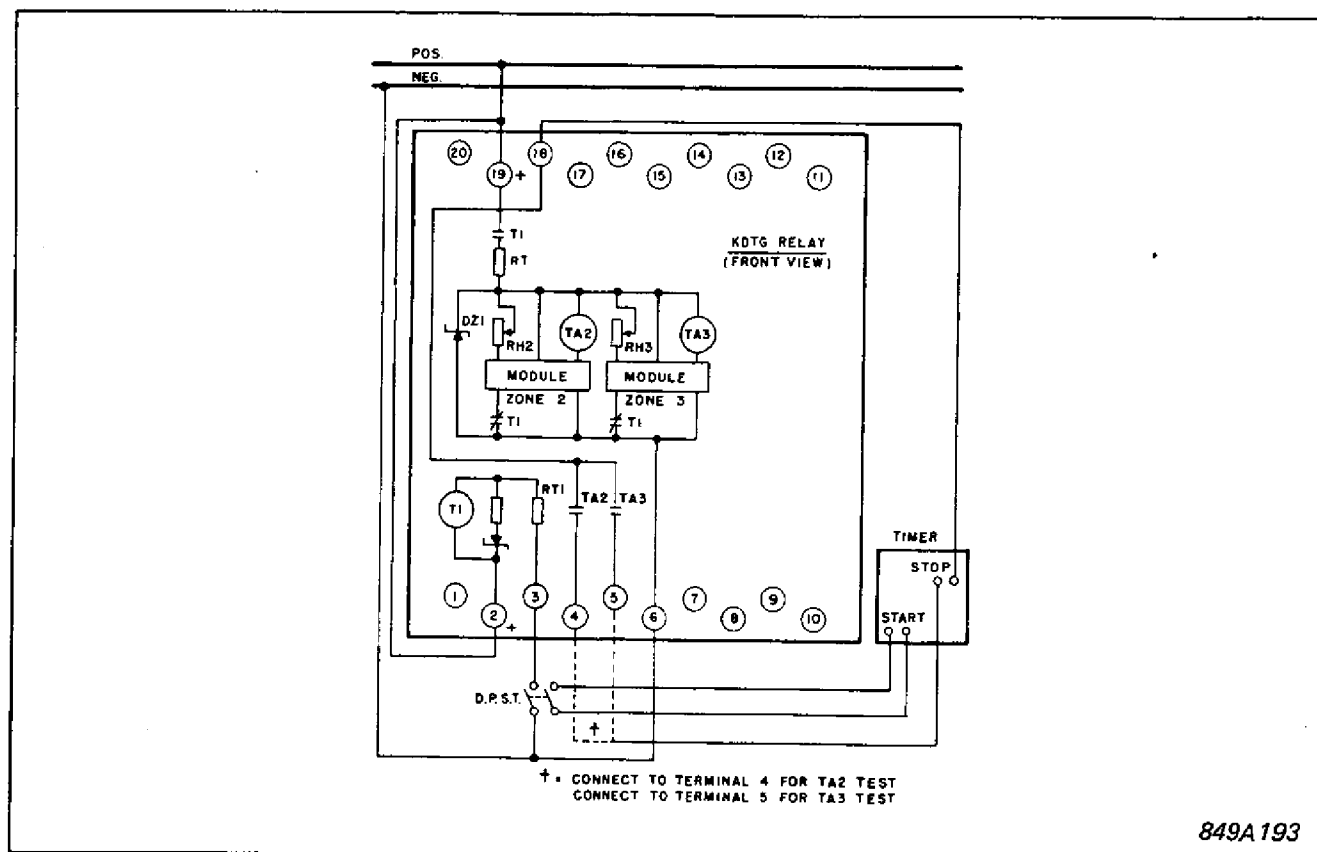
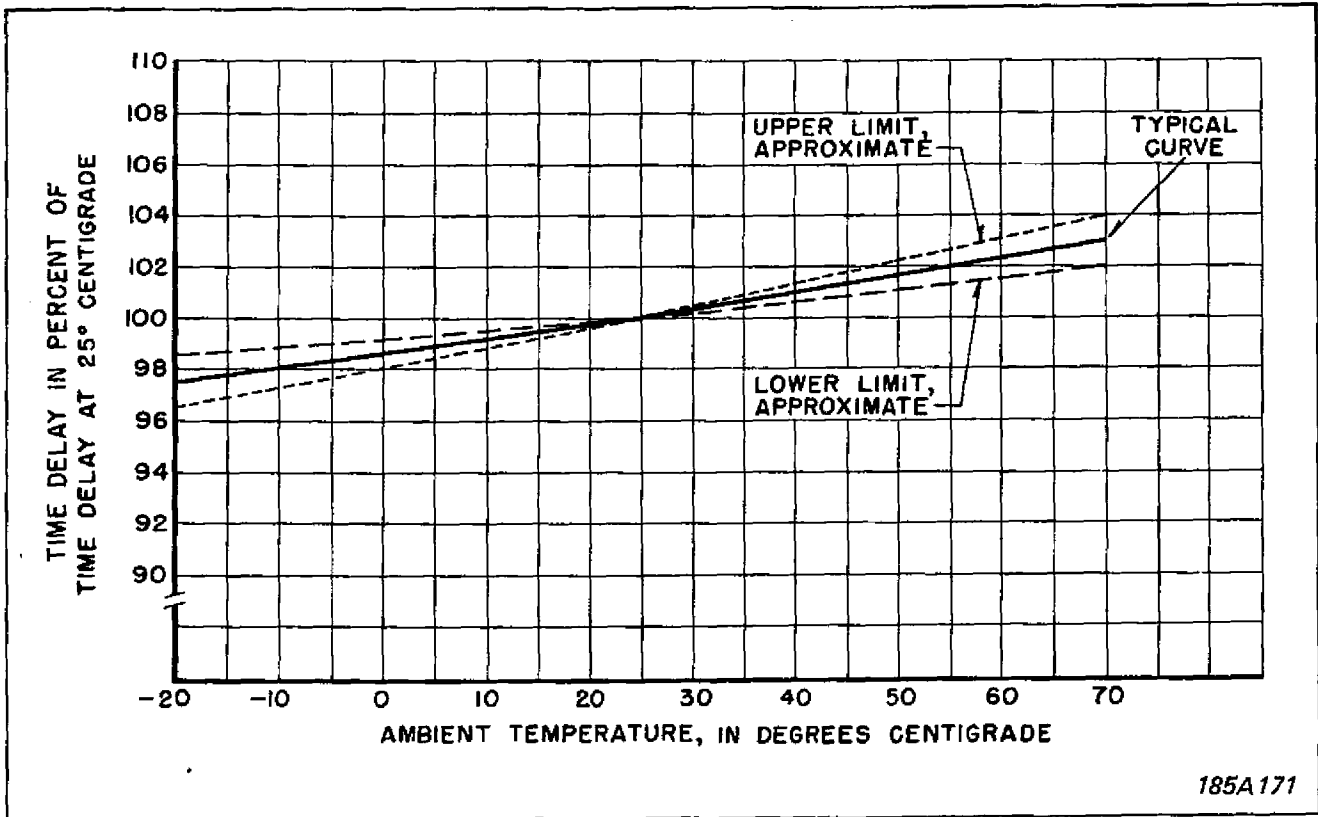
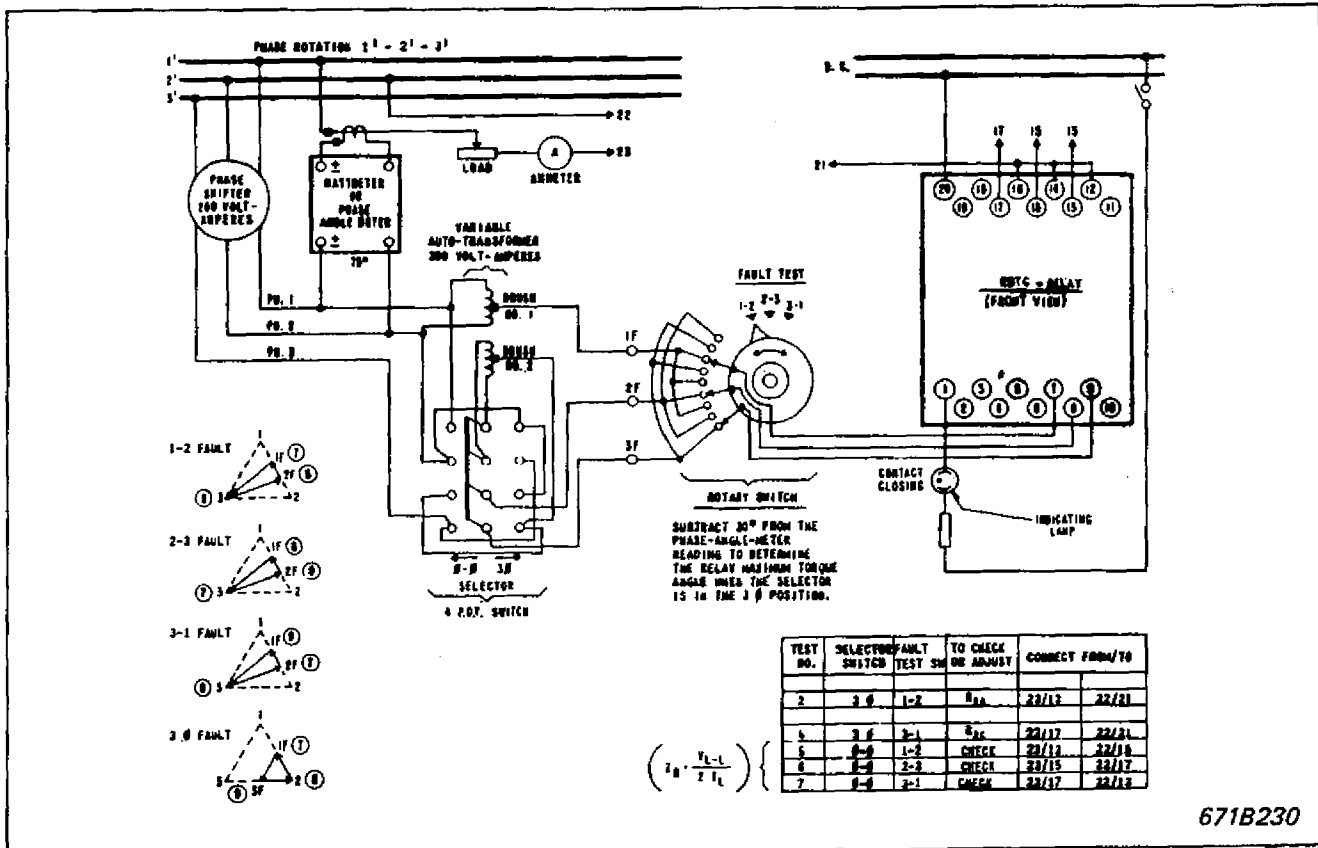

Fig. 4. Timer Test Connection Circuit for the Type KDTG Relay.



185A171

Fig. 5. Timing Variation with Temperature for the Type KDTG Relay.



671B230

Fig. 6. Distance Unit Test Circuit for Type KDTG Relay.

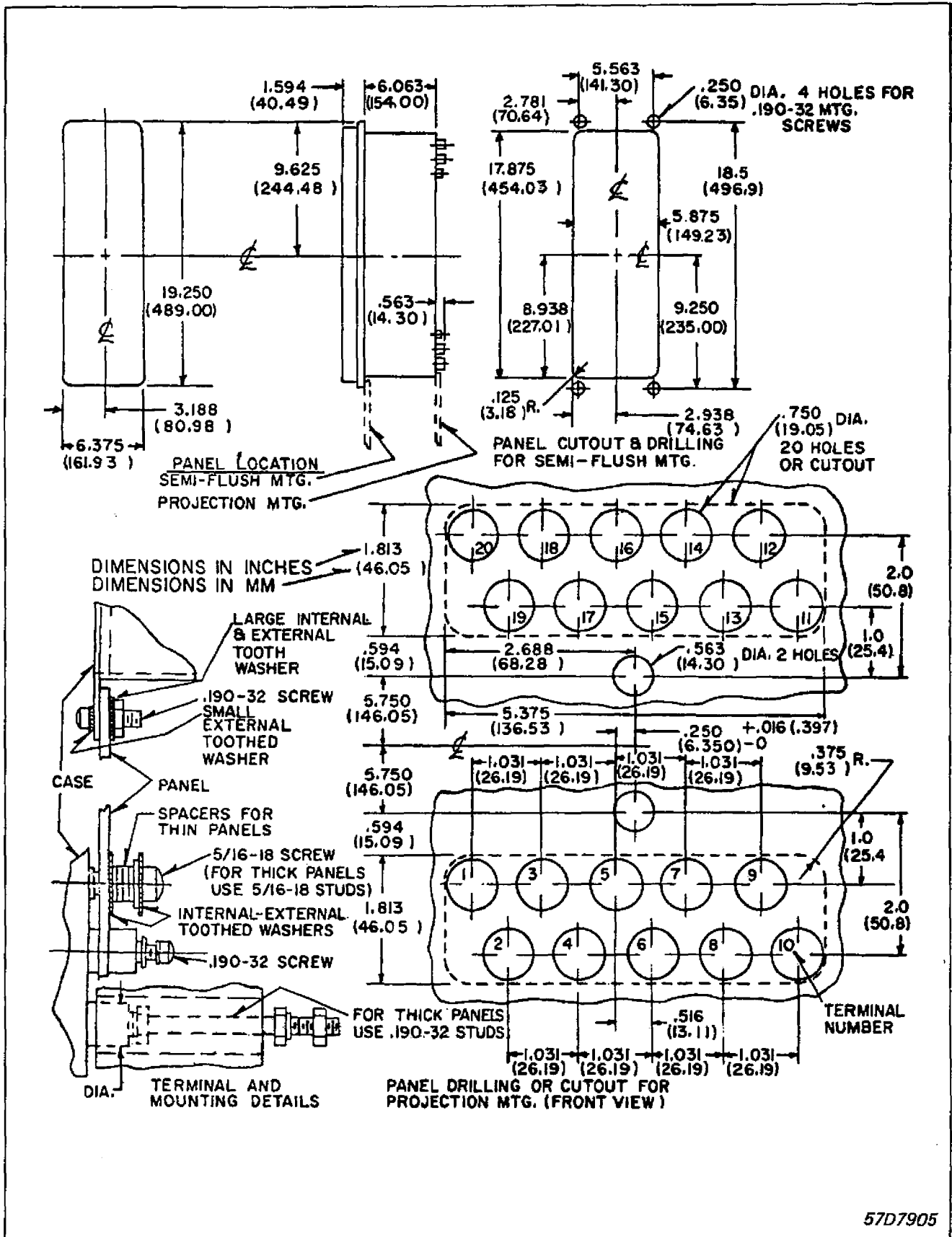

Fig. 7. Outline-Drilling Plan for the Type KDTG Relay in the FT-42 Case.



ABB Inc.

4300 Coral Ridge Drive
Coral Springs, Florida 33065

Telephone: +1 954-752-6700

Fax: +1 954-345-5329

www.abb.com/substation_automation

IL 41-497.2 - Revision D