

SPAU 140 C

Synchro-check relay

User's manual and Technical description

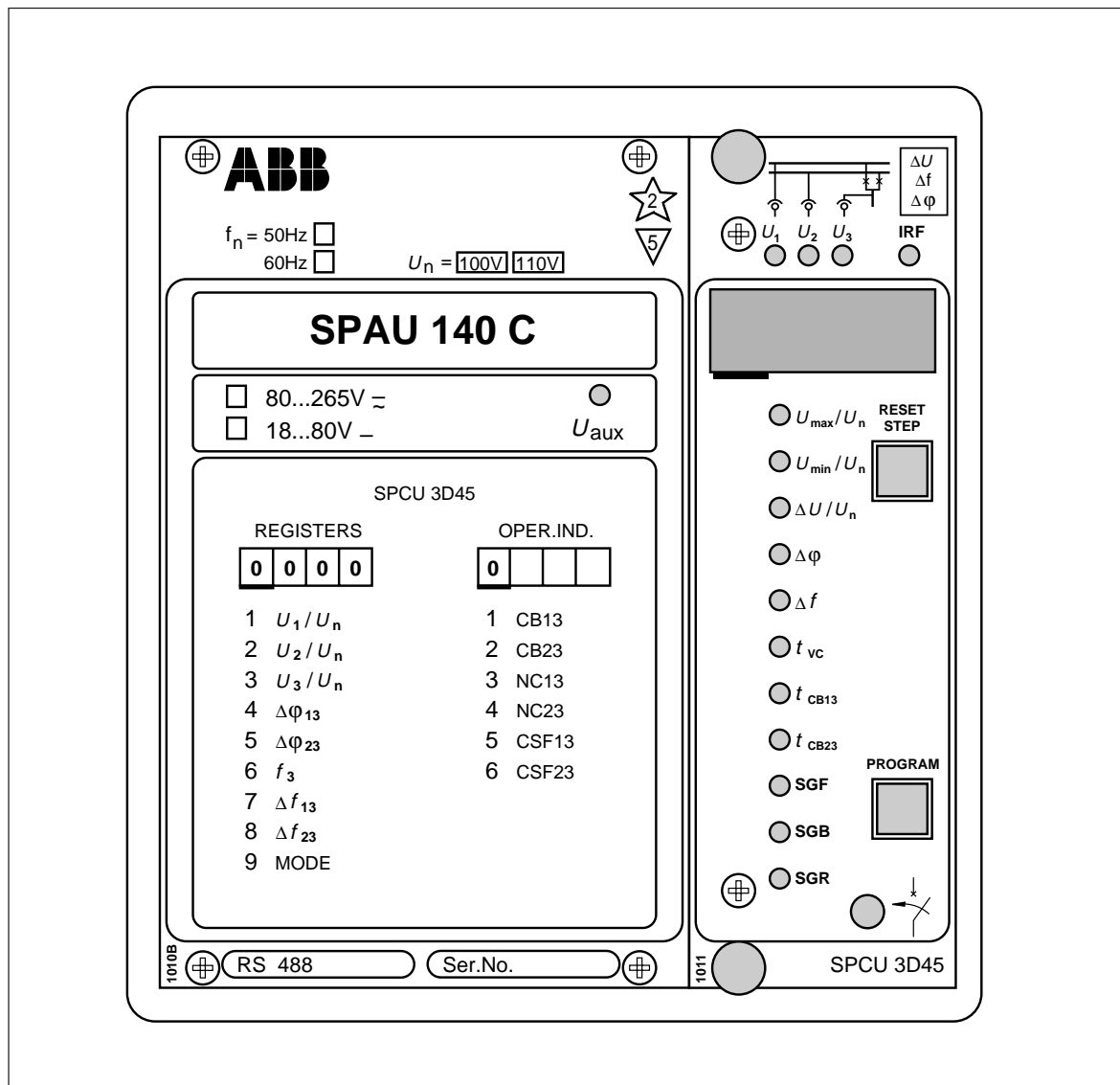

Data subject to change without notice

| | | |
|-----------------|--|----|
| Contents | Features | 3 |
| | Application | 3 |
| | Description of operation | 4 |
| | Connection diagram | 6 |
| | Connections | 8 |
| | Application example 1 | 9 |
| | Application example 2 | 10 |
| | Intermodular signals | 11 |
| | Operation indicators | 12 |
| | Power supply and output relay module | 13 |
| | Technical data | 13 |
| | Commissioning and testing | 16 |
| | Maintenance and repairs | 18 |
| | Exchange and spare parts | 18 |
| | Order numbers | 18 |
| | Order data | 18 |
| | Dimensions and instructions for mounting | 19 |

In addition to this general description the following documents are included in the complete manual:

| | |
|---|--------------------|
| Synchro-check relay module type SPCU 3D45 | 1MRS 750195-MUM EN |
| General characteristics of D-type SPC relay modules | 1MRS 750066-MUM EN |

Features

Synchro-check relay for checking the conditions at circuit breaker closing

One synchro-check relay is capable of checking the close conditions of two separate circuit breakers.

Synchro-check function for checking synchronism when live lines/busbars are to be connected together.

Voltage-check function for checking energizing conditions. Four energizing directions selectable for each circuit breaker.

Two control modes available: continuous mode operation for applications where the synchro-check relay gives the close permission to another module (e.g. the control module) and command mode operation for applications where the relay closes the circuit breaker via its own control output.

Alarm signal for failed CB closing at command mode operation

Continuous self-supervision of both hardware and software

Serial port for connecting the relay to the electrical or optical SPA bus

Application

The synchro-check relay SPAU 140 C is an integrated microprocessor-based voltage measuring relay designed to be used for checking the conditions for circuit breaker closing. The relay

can be used for closing ring mains, interconnecting busbars and connecting generators to the network.

Description of operation

The relay incorporates two identical stages which operate as independent units. Both stages of the synchro-check relay has two parallel functions: a synchro-check function and a voltage-check function.

The synchro-check relay can be used for two different operating conditions, the most typical of which is where both sides of the circuit breaker to be closed are live. Then synchronism is always checked before the circuit breaker is given the permission to close. The other situation is where one or both sides of the circuit breaker to be closed are dead and, consequently, frequency and phase difference cannot be measured. In this case the relay checks the energizing direction. The user is able to define the voltage range within which the measured voltage is determined to be "live" and "dead".

The purpose of the synchro-check function is to find the instant when the voltages on both sides of the circuit breaker are in synchronism. The conditions for synchronism are met when the voltages on both sides of the circuit breaker have the same frequency, are in phase and are of such a magnitude that the concerned busbars or lines can be regarded as live.

When the frequency, phase angle and voltage conditions are fulfilled, the duration of the synchronizing conditions is checked so as to ensure that they will still be met when the con-

tacts of the circuit breaker close. This duration is determined on the basis of the frequency and phase difference measured. Depending on the circuit breaker and the closing system, the delay from the moment the closing signal is given until the circuit breaker finally closes is about 50 - 250 ms. The CB operate time selected tells the relay for how long, at least, the conditions have to persist.

The voltage-check function checks the energizing direction. Energizing is defined as the situation where a dead network part is connected to an energized section of the network. The conditions of the network sections to be controlled by the circuit breaker, i.e. which side has to be live and which side dead, are determined by setting. A situation where both sides are dead is possible as well.

When the energizing direction corresponds to the settings, the situation has to be constant for a certain time before the close signal is permitted. The purpose of this operate time (dead time) is to make sure that the dead side remains deenergized and that the situation is not due to a temporary interference. Should the conditions not persist for the specified operate time, the operate time is reset and the procedure is started again when allowed by the conditions. Not until the required energizing situation has been constant throughout the set operate time, circuit-breaker closing is permitted.

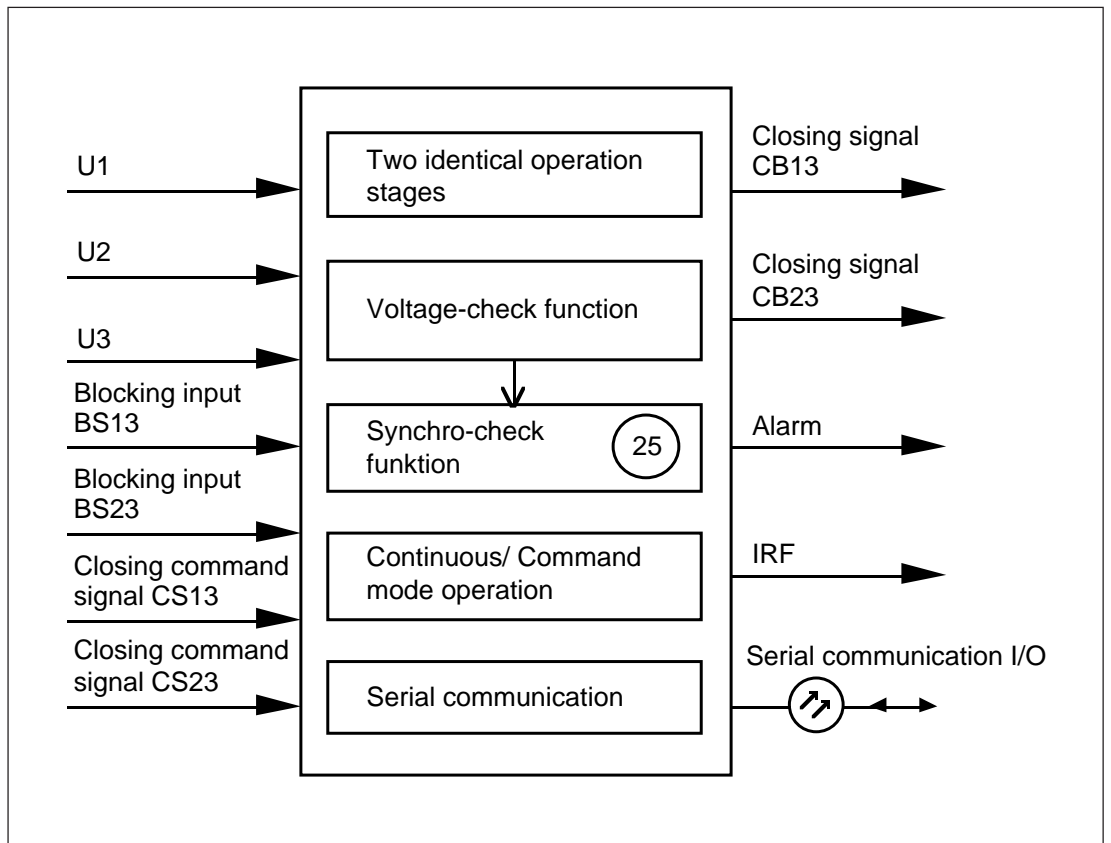

Fig. 1. Supervision functions of synchro-check relay SPAU 140 C. The encircled numbers refer to the ANSI number of the concerned function. (ANSI = American National Standards Institute)

Connection diagram

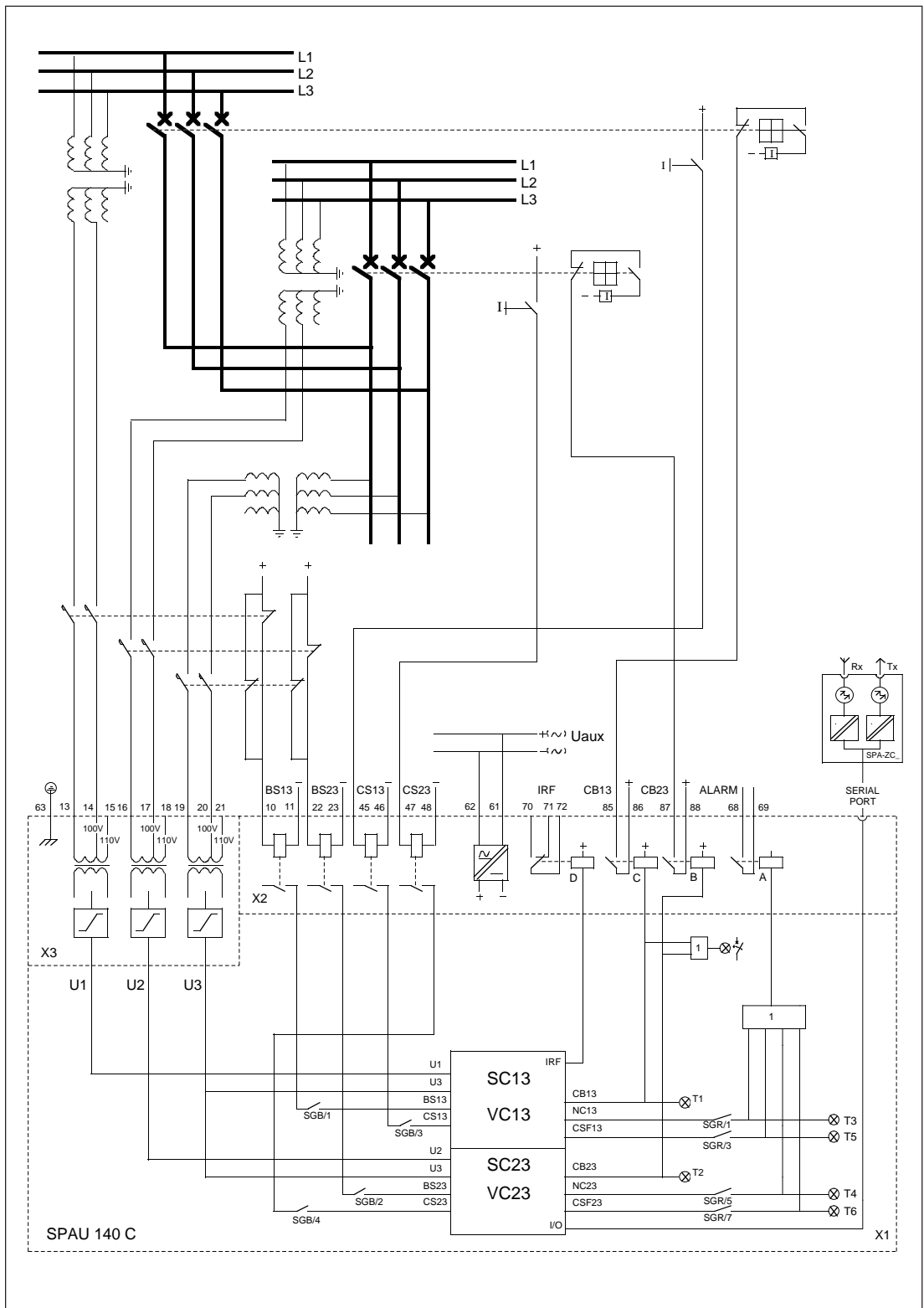

Fig. 2. Complete connection diagram for the synchro-check relay SPAU 140 C. The switches for configuring the control signals of the output relays and the external blocking/control inputs are illustrated in the diagram.

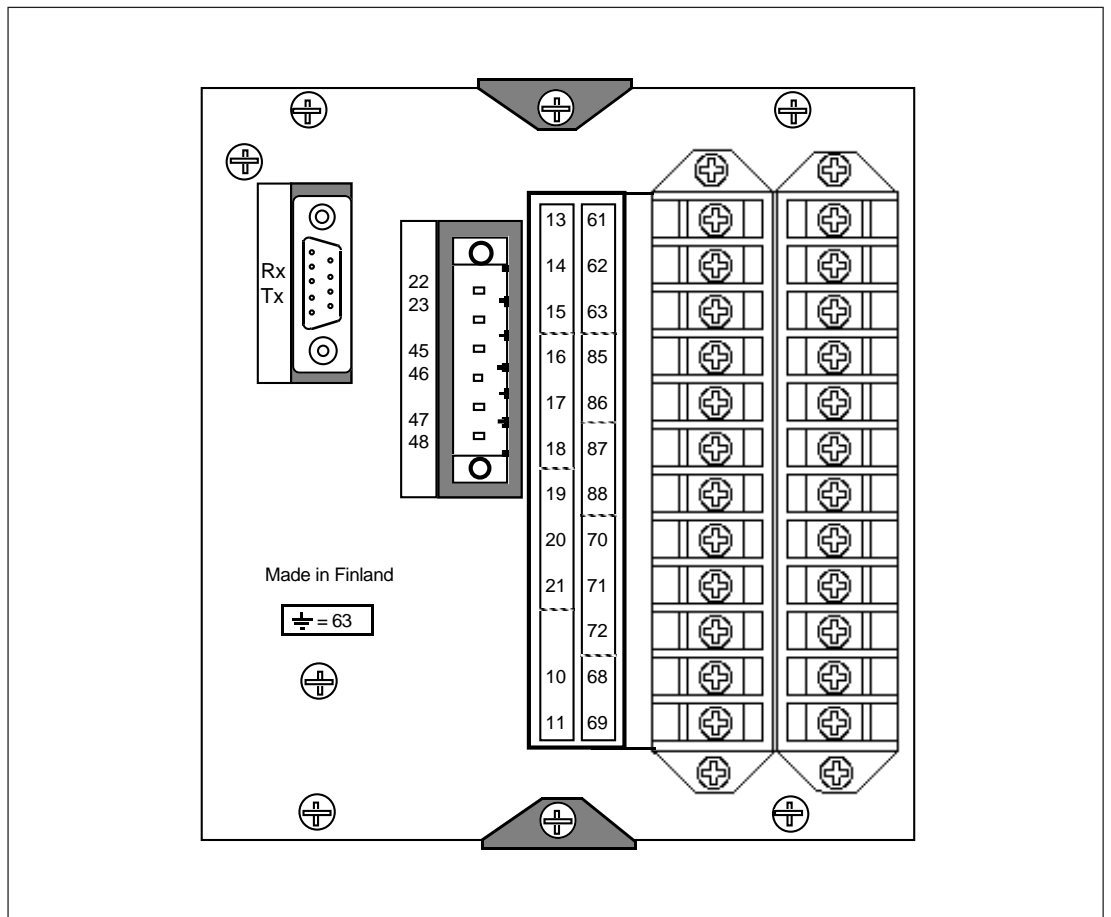

Fig. 3. Rear view of synchro-check relay SPAU 140 C

| | |
|-------------|---|
| U_{aux} | Auxiliary voltage |
| A,B,C,D | Output relays |
| IRF | Self-supervision |
| SGB | Switchgroup for the configuration of blocking and command signals |
| SGR | Switchgroup for the configuration of alarm signals |
| CB13 | Circuit breaker close permission/close command, stage 1 |
| CB23 | Circuit breaker close permission/close command, stage 2 |
| ALARM | Signal output |
| BS13 | Blocking signal for stage 1 |
| BS23 | Blocking signal for stage 2 |
| CS13 | Control signal, request for CB closing, stage 1 |
| CS23 | Control signal, request for CB closing, stage 2 |
| X1 | Synchro-check relay module SPCU 3D45 |
| X2 | Power supply and output relay module SPTU 240 R4 or SPTU 48 R4 |
| X3 | Input module SPTE 3E10 |
| T1...T6 | Operation indicators 1...6 |
| SERIAL PORT | Serial port for serial communication |
| SPA-ZC | Bus connection module |
| Rx Tx | Receiver (Rx) and transmitter (Tx) for the connection of optical fibres |

| Terminal | Function |
|----------|---|
| 13-14 | Measured voltage U1, rated voltage 100 V |
| 13-15 | Measured voltage U1, rated voltage 110 V |
| 16-17 | Measured voltage U2, rated voltage 100 V |
| 16-18 | Measured voltage U2, rated voltage 110 V |
| 19-20 | Measured voltage U3, rated voltage 100 V |
| 19-21 | Measured voltage U3, rated voltage 110 V |
| | The relay is able to measure either phase-to-phase voltages or phase-to-neutral voltages, but phase-to-phase voltages are preferred. |
| 10-11 | Stage 1 of the synchro-check relay can be blocked by applying an external auxiliary voltage level blocking signal BS to terminals 10-11. The blocking function is selected with switch 1 of switchgroup SGB in the main menu of the relay. The blocking function is not activated in the default setting of the relay. |
| 22-23 | Stage 2 of the synchro-check relay can be blocked by applying an external auxiliary voltage level blocking signal BS to terminals 22-23. The blocking function is selected with switch 2 of switchgroup SGB in the main menu of the relay. The blocking function is not activated in the default setting of the relay. |
| 45-46 | When command mode operation has been selected for stage 1, the stage is activated for CB closing by an auxiliary voltage level control signal CS13, applied to the terminals 45-46. If continuous mode operation has been selected no control signal need be applied to the relay. Switch 3 of switchgroup SGB is used for selecting the desired mode of operation. Default setting of stage 1: continuous mode operation. |
| 47-48 | When command mode operation has been selected for stage 2, the stage is activated for CB closing by an auxiliary voltage level control signal CS23, applied to the terminals 47-48. If continuous mode operation has been selected no control signal need be applied to the relay. Switch 4 of switchgroup SGB is used for selecting the desired mode of operation. Default setting of stage 2: continuous mode operation. |
| 68-69 | At command mode operation the alarm signal for failed circuit breaker closing (NC13 and NC23) and for CB close request signals that have remained activated (CSF13 and CSF23) is received via output relay A at command mode operation. The switches 1, 3, 5 and 7 of switchgroup SGR are used for the configuration of the alarm signals. No alarm signals are received at continuous mode operation. |
| 87-88 | Output relay B provides the permission signal for CB closing via stage 2 of the synchro-check relay module. |
| 85-86 | Output relay C provides the permission signal for CB closing via stage 1 of the synchro-check relay module. |
| 70-71-72 | Output relay D, terminals 70-71-72, operates as the output relay of the self-supervision system of the synchro-check relay. Normally, the relay operates on the closed-circuit principle and the contact gap 70-72 is closed. If the self-supervision system detects a permanent fault or the voltage supply to the relay fails, the output relay D provides an alarm signal by closing the normally open contact gap 71-72. |
| 61-62 | The auxiliary supply voltage of the synchro-check relay is connected to terminals 61-62. At DC supply voltage the positive lead is connected to terminal 61. The permitted voltage range of the power supply and output relay module fitted in the relay module is indicated on the front panel of the relay. Further technical details about the auxiliary voltage supply system is given in the section "Power supply and output relay module". |

The synchro-check relay is connected to the data communication bus and, further, to a control data communicator, e.g. SACO 148D4, via the

9-pole, D-type subminiature connector located on the rear of the relay and a bus connection module type SPA-ZC17_, or SPA-ZC21_.

Application example 1

The network and the generator running in parallel with the network are connected together through the line AB. When a fault occurs between A and B the relay protection opens the circuit breakers A and B, thus isolating the faulty section from the network and making the arc that caused the fault extinguish. The first attempt to recover is a delayed auto-reclosure made a few seconds later. Then the auto-reclose relay gives a command signal to the synchro-check relay to close the circuit breaker A. The synchro-check relay SPAU 140 C performs a voltage check, as the line AB is deenergized

($U1 > U_{max}$, $U3 < U_{min}$). After verifying that the line AB is dead and that the energizing direction is correct, the relay energizes the line ($U1 > U3$) by closing circuit breaker A. Then the PLC of the power plant discovers that the line has been energized and sends a signal to the other synchro-check relay to close circuit breaker B. Since both sides of circuit breaker B are live ($U1 > U_{max}$, $U3 > U_{max}$), the synchro-check relay controlling circuit breaker B performs a synchro-check and, if the network and the generator are in synchronism, closes the circuit breaker.

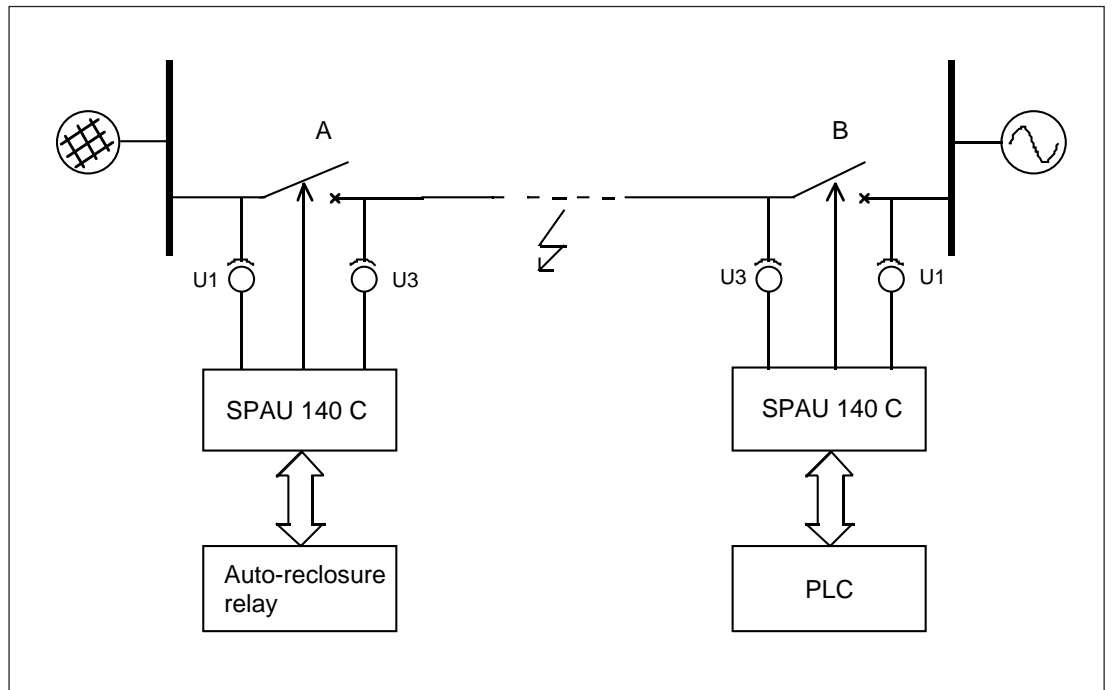

Fig. 4. Synchro-check relay SPAU 140 C checking energizing conditions and synchronism.

Application example 2

Synchronism check between busbar and line

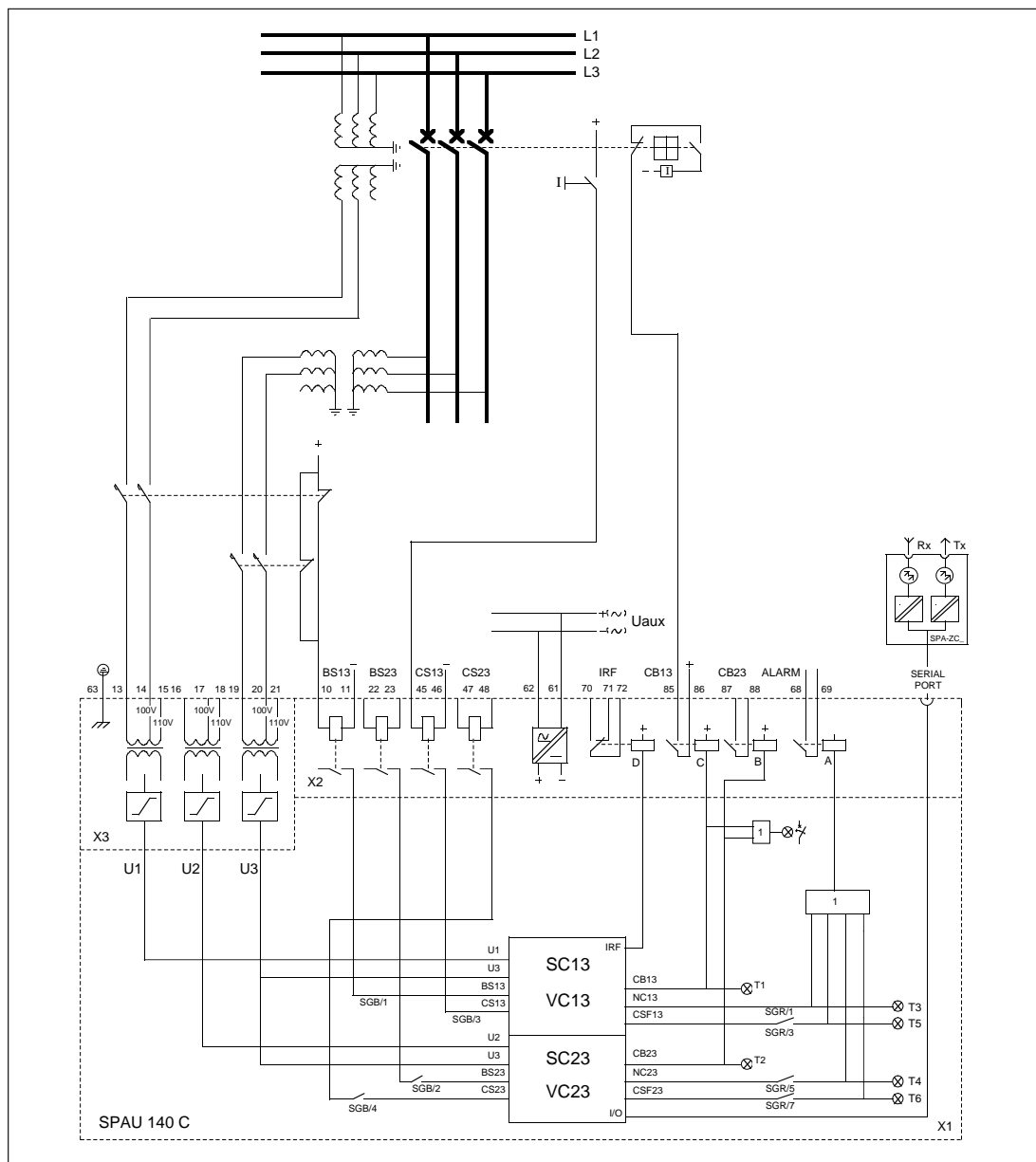

Fig. 5. Synchro-check relay SPAU 140 C used for checking synchronism between busbar and line

In the application illustrated in Fig. 5 stage 1 of the synchro-check relay is used for checking the synchronism between the busbar and the line. Stage 2 is inactive ($SGF/7 = 0$ and $SGF/8 = 0$). Both the synchro-check function and the voltage-check function of stage 1 are operational ($SGF/3 = 1$ and $SGF/4 = 1$).

Command mode operation has been selected for stage 1 ($SGB/3 = 1$), which means that pressing a push-button activates a request signal for the synchro-check relay to close the circuit breaker. This request signal should be active throughout the specified checking time. The permission for the relay to operate is given over this request input, and once the conditions for CB closing are met, the synchro-check relay delivers a close signal to the circuit breaker via output contact C. Should the attempt to close the circuit breaker fail ($SGR/1 = 1$), that is, the cir-

cuit breaker is not closed within the preset time, an alarm signal will be received through contact A.

A blocking voltage applied to the blocking input BS13 ($SGB/1=1$) over the auxiliary contact of the miniature circuit breaker prevents the synchro-check relay from performing the voltage-check function when the miniature circuit breaker trips. It is very important that the voltage-check function is prevented by the tripping of the m.c.b. Unless a blocking signal has been provided, the synchro-check relay measures the voltage over this input to be zero and, should the energizing conditions then correspond to the setting concerned ($SGF/1$ and $SGF/2$), it gives a close signal to the circuit breaker, when the command input (push-button depressed) is active.

Intermodular control signals

The figure below illustrates the configuration of the blocking and control signals (SGB) and alarm signals (SGR), and the selection of the check functions (SGF) of the stages.

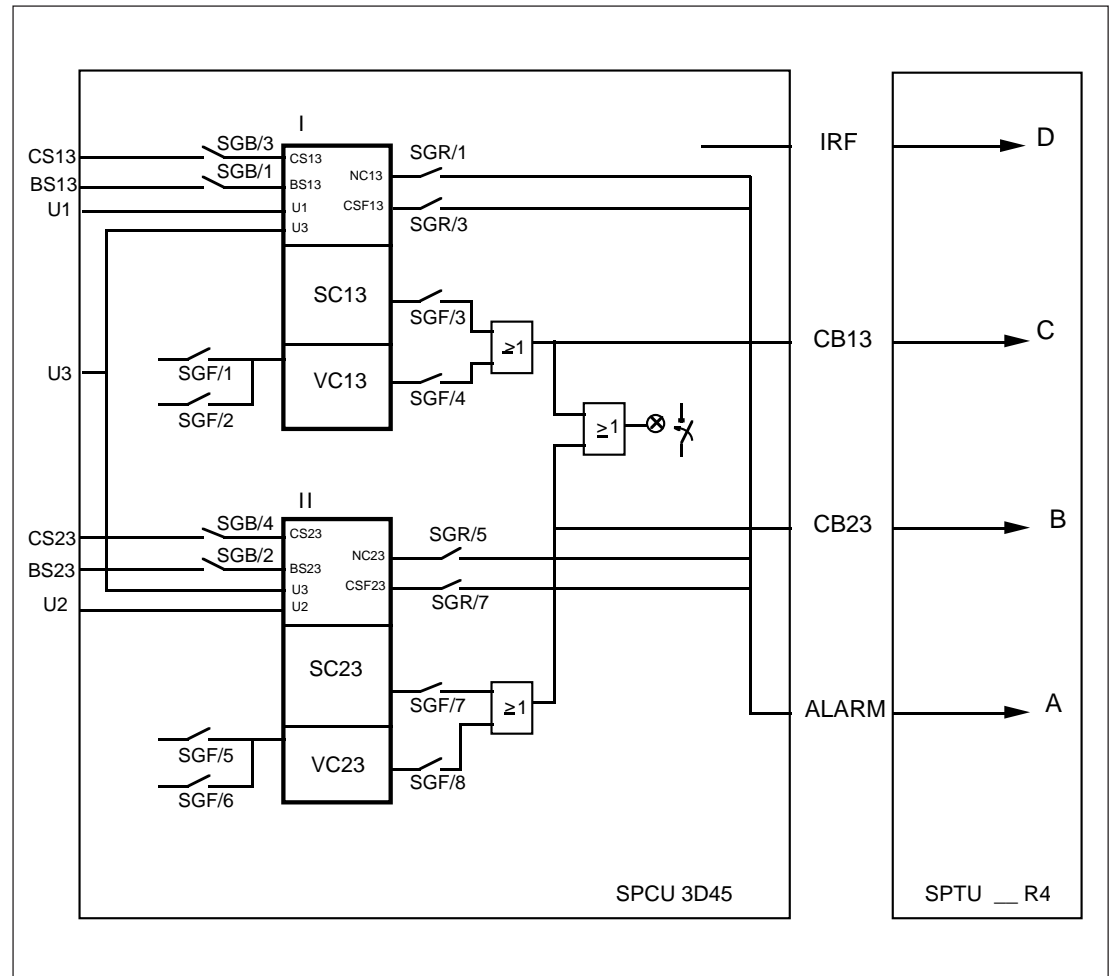
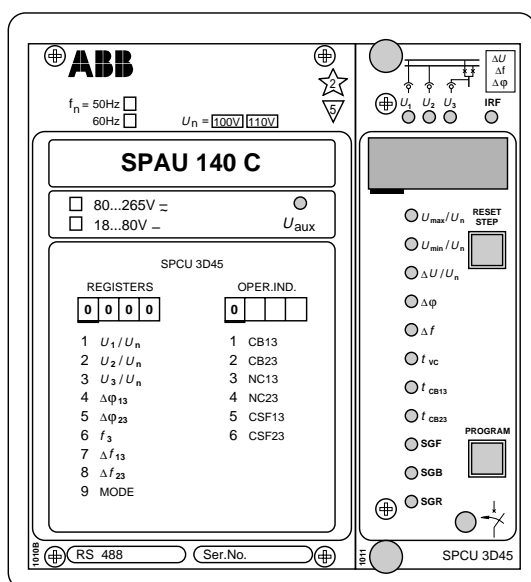

Fig. 6. Control signals between the modules of the synchro-check relay SPAU 140 C and the configuration switches.

| | |
|----------|--|
| U1,U2,U3 | Measured voltages |
| CB13 | Close permission/close command, stage 1 |
| CB23 | Close permission/close command, stage 2 |
| ALARM | Alarm signal from stages 1 and 2 |
| BS13 | External blocking signal to stage 1 |
| BS23 | External blocking signal to stage 2 |
| CS13 | External control signal to stage 1, request for CB closing |
| CS23 | External command signal to stage 2, request for CB closing |
| IRF | Signal for internal relay fault |
| SGF | Switchgroup for configuring the functions of the synchro-check relay |
| SGB | Switchgroup for configuring the blocking and command functions |
| SGR | Switchgroup for configuring the alarm functions |

Operation indicators



The yellow operation indicator is lit as soon as one of the stages of the relay operates and has activated its control output. When the stage resets, the yellow LED is reset as well.

The leftmost red digit on the display has two functions: on one hand, it serves as address indicator for different types of data and, on the other hand, as operation indicator of the two stages of the synchro-check relay. Operation is indicated by a red digit, 1 or 2, depending on which of the stages that activated its close signal.

The red digits 3, 4, 5 and 6 indicate an abnormal situation at command mode operation. These alarm indicators remain lit even when the situation returns to normal, and have to be reset by pressing the reset push-button. A non-reset operation indicator does not affect the operation of the relay module, which is always alert. The following table, which is printed on the relay's front plate under the name OPER. IND., explains the code numbers of the operation indicators.

| Operation indicator | Explanation |
|---------------------|--|
| 1 | CB13 Close signal of stage 1 is active |
| 2 | CB23 Close signal of stage 2 is active |
| 3 | NC13 Stage 1 failed to close the CB (only command mode operation) |
| 4 | NC23 Stage 2 failed to close the CB (only command mode operation) |
| 5 | CSF13 Signal CS13 requesting CB closing is active too long (only command mode operation) |
| 6 | CSF23 Signal CS23 requesting CB closing is active too long (only command mode operation) |

The IRF LED indicates internal relay fault. The indicator is lit about 1 minute after the self-supervision system has detected a permanent fault. At the same time as the LED goes on the relay module delivers a control signal to the output relay of the self-supervision system. In most cases

a fault code that shows the nature of the fault appears on the display of the relay module. This fault code that consists of a red digit 1 and a green code number cannot be reset from the display. The code should be recorded to facilitate service.

Power supply and output relay module

The combined power supply and I/O relay module is located behind the relay's system panel. The module incorporates the power supply unit, the output relays with control circuits, and the electronic circuits of the external control input. The power supply and output relay module can be withdrawn after removal of the system panel of the relay.

The power supply module is a transformer connected, i.e. galvanically isolated primary and secondary side, flyback-type DC/DC converter. The primary side of the module is protected with a fuse, F1, located on the PCB of the module. The fuse size is 1 A (slow).

A green LED indicator U_{aux} on the system panel is lit when the power supply module is in operation.

The combined power supply and I/O modules are available in two versions with different input voltage ranges:

| | |
|------------|--------------------------------------|
| SPTU 240R4 | $U_{aux} = 80...265 \text{ V dc/ac}$ |
| SPTU 48R4 | $U_{aux} = 18...80 \text{ V dc}$ |

The system panel of the relay indicates the voltage range of the power supply module of the relay assembly.

Technical data

Energizing inputs

| | 100 V | 110 V |
|-------------------|---------------------|---------------------|
| Energizing inputs | 13-14, 16-17, 19-20 | 13-15, 16-18, 19-21 |
| Rated voltage | 100 V | 110 V |

| | |
|------------------------------|------------------|
| Continuous voltage withstand | $2.0 \times U_n$ |
| Burden at rated voltage | <0.5 VA |
| Rated frequency | 50 Hz / 60 Hz |
| Permissible frequency range | 45...65 Hz |

Output contacts

| | |
|---|--------------------|
| Terminals | 85-86, 87-88 |
| - rated voltage | 250 V ac/dc |
| - carry continuously | 5 A |
| - make and carry for 0.5 s | 30 A |
| - make and carry for 3.0 s | 15 A |
| - breaking capacity for dc, when the control circuit time-constant $L/R < 40 \text{ ms}$ at 48/110/220 V dc control circuit voltage | 5 A/3 A/1 A |
| Contact material | AgCdO ₂ |

Signal contacts

| | |
|---|--------------------|
| Terminals | 70-71-72 |
| | 68-69 |
| - rated voltage | 250 V ac/dc |
| - carry continuously | 5 A |
| - make and carry for 0.5 s | 10 A |
| - make and carry for 3.0 s | 8 A |
| - breaking capacity for dc, when the control circuit time-constant $L/R < 40 \text{ ms}$ at 48/110/220 V dc control circuit voltage | 1 A/0.25 A/0.15 A |
| Contact material | AgCdO ₂ |

External control inputs

| | |
|--|--------------------------------|
| Terminals | 10-11, 22-23, 45-46, 47-48 |
| External control voltage level | 18...265 V dc or 80...265 V ac |
| Typical control current of input circuit | 2...20 mA |

Power supply and output relay module

| | |
|--|------------------|
| Module, type SPTU 240 R4 | 80...265 V dc/ac |
| Module, type SPTU 48 R4 | 18...80 V dc |
| Power consumption under quiescent/operating conditions | about 5 W/7 W |

Synchro-check relay module SPCU 3D45

Synchro-check function

| | |
|---|----------------------------|
| Upper voltage level threshold U_{\max} Setting range | 0.5...1.0 x U_n |
| Voltage difference ΔU Setting range | 0.02...0.4 x U_n |
| Frequency difference Δf Setting range | 0.02...0.5 Hz |
| Phase difference $\Delta\phi$ | 5...50° |
| Operate time when the voltage on the energizing input rises from 0 to 1.0 x U_n | 160 ms \pm 20 ms (fixed) |

Operate time t_{CB13} of CB controlled by stage 1 0.05...0.25 s

Operate time t_{CB23} of CB controlled by stage 2 0.05...0.25 s

Voltage-check function

Upper voltage level threshold U_{\max}
(the same as for the synchro-check function)
Setting range 0.5...1.0 x U_n

Lower voltage level threshold U_{\min}
Setting range 0.1...0.8 x U_n

Energizing direction

Selectable energizing directions for stage 1

- both dead or $U1 \rightarrow U3$ or $U1 \leftarrow U3$
- $U1 \leftarrow U3$
- $U1 \rightarrow U3$
- $U1 \leftarrow U3$ or $U1 \rightarrow U3$

Selectable energizing directions for stage 2

- both dead or $U2 \rightarrow U3$ or $U2 \leftarrow U3$
- $U2 \leftarrow U3$
- $U2 \rightarrow U3$
- $U2 \leftarrow U3$ or $U2 \rightarrow U3$

Operate time delay t_{vc} (dead time)

- setting range 0.1...20 s
- setting accuracy 0.01 s

Mode of operation

Command mode or continuous mode operation

Command mode operation

Max. close signal length t_{PULSE} at
command mode operation

Setting range 0.2...20 s

Time permitted for checking and request
for CB closing t_{CHECK}

Setting range 0.05...300 s

Data transmission

Transmission mode

Fibre-optic serial bus

Data code

ASCII

Data transfer rates

4800 Bd or 9600 Bd

Bus connection module without external supply

- for plastic core cables

SPA-ZC 21 BB

- for glass fibre cables

SPA-ZC 21 MM

Bus connection module with external supply

- for plastic core cables

SPA-ZC 17 BB

- for glass fibre cables

SPA-ZC 17 MM

Test voltages

Insulation test voltage, inputs and outputs
between themselves and to the relay frame as
per IEC 255-5 and SS 436 15 03

2 kV, 50 Hz, 1 min

Impulse test voltage, inputs and outputs
between themselves and to the relay frame as
per IEC 255-5 and SS 436 15 03

5 kV, 1.2/50 μ s, 0.5 J

Insulation resistance as per IEC 255-5

100 M Ω , 500 V dc

Disturbance tests

High frequency interference test voltage,
inputs and outputs between themselves
and to the relay frame as per IEC 255-22-1
and SS 436 15 03

2.5 kV, 1 MHz

Fast transients as per IEC 255-22-4

Class III, 2 kV

Electrostatic discharge test as per IEC 255-22-2

8 kV, 150 pF

Environmental conditions

Specified ambient service temperature range

-10...+55°C

Temperature influence on the operation values
of the relay over the specified ambient service
temperature range

<0.1%/°C

Long term damp heat withstand according
to IEC 68-2-3

<95% at 40°C, 96 h

Transport and storage temperature range

-40...+70°C

Degree of protection by enclosure of relay case
according to IEC 529 at panel mounting

IP54

Weight of relay

about 3.0 kg

Commissioning and testing

The relay incorporates a self-supervision logic that continuously supervises the operation of the relay and provides an IRF alarm when an internal relay fault is detected. However, the manufacturer recommends regular testing of the relay, for instance, every five years. This test should be carried out as a primary test, which includes the entire supervision chain covered by

the synchro-check relay, from the instrument transformers to the circuit breakers.

Special attention should be paid to the connection of the relay. Further, it should be checked that the primary side wiring is correct. The table below can be used for checking the wiring.

Measuring circuit wiring and wiring test

Faulty wiring of the voltage inputs of the relay will cause malfunction in the synchro-check relay. If the wires of an energizing input have changed places, the polarity of the voltage of the input is reversed (180°). Then the relay permits circuit breaker closing in a situation where the voltages actually are in opposite phases. For

this reason it is extremely important that the wiring from the voltage transformers to the terminals on the rear of the relay is consistent regarding the energizing inputs U1, U2 and U3.

The table below shows the energizing inputs and the related terminals.

| Energizing input U1/100 V | | Energizing input U2/100 V | | Energizing input U3/100 V | |
|---------------------------|----|---------------------------|----|---------------------------|----|
| Terminal | 13 | | 16 | | 19 |
| | 14 | | 17 | | 20 |

| Energizing input U1/110 V | | Energizing input U2/110 V | | Energizing input U3/110 V | |
|---------------------------|----|---------------------------|----|---------------------------|----|
| Terminal | 13 | | 16 | | 19 |
| | 15 | | 18 | | 21 |

The wiring should be verified by checking the reading of the phase difference measured between the voltages U1 and U3 and between the voltages U2 and U3. When checking the phase differences the circuit breaker between the concerned voltages have to be closed, to make sure there is no phase difference. The phase difference measured by the relay has to be close to zero within the permitted accuracy tolerances. The phase differences measured are indicated

in the third submenu of the LEDs U1 and U2. At the same time it is recommended to check the voltage difference and the frequency differences presented in the first and the second submenu, respectively. These values should be within the permitted tolerances, close to zero. The frequency measured from the network, for example 50 Hz, can be read in the first submenu of the U3 indicator.

Miniature circuit-breakers of the voltage measuring circuits

Supervision of the condition of the relay's external measuring circuit is not incorporated in the synchro-check relay. Should the external measuring circuit of some reason be damaged, malfunction may follow, and based on the voltage measured, the relay then considers the line/busbar to be dead, although it actually is energized. In consequence, a voltage-check is made, and, if the energizing direction corresponds to the relay setting, a close permission/command is given. Then the close operation is made against a live section without the synchronism being checked, as the energizing conditions were considered to be fulfilled. For this reason it is important that the safety switch of the measuring circuit, when operating, provides the synchro-check relay with a blocking signal that prevents circuit breaker closing. When the relay is commissioned, it should be checked that the blocking function operates correctly and that the configuration of the blocking signals (SGB switchgroup) is in order. The states of the individual blocking signals can be checked in the first submenu of register 0.

The miniature circuit-breakers of the measuring circuit and the blocking function can be tested as follows.

- Enable blocking of the stages by selecting the checksum 3 for the switchgroup SGB. Then stage 1 is blocked by the signal BS13 and stage 2 by the signal BS23.

- Configure switchgroup SGF so that the checksum is 136. Then the stages operate when the operate time t_{vc} expires. Stage 1 activates the output signal CB13 and stage 2 the output signal CB23. The blocking function should operate so that an activated output signal resets, when the blocking input of the stage is activated; the blocking signal BS13 resets the output CB13 and the blocking signal BS23 resets the output CB23. When the blocking has been eliminated, the output returns to its active state.

Alternatively, the test can be carried out so that switchgroup SGB is given the checksum value 3 and switchgroup SGF the checksum value 0 and then the blocking signals to the stages are activated. The next step is to give switchgroup SGF the checksum value 136, which enables the voltage-check function of both stages. After the setting value has been changed the output signal of neither stage is allowed to activate. Finally, the blocking of the stages is eliminated and then the output signal has to be activated when the preset operate time expires.

| | | |
|--------------------------------|---|--|
| Maintenance and repairs | When the synchro-check relay is used under the conditions specified in "Technical data", it requires practically no maintenance. The relay includes no parts or components that are sensitive to physical or electrical wear under normal operating conditions. | If the relay malfunctions or the operating values differ from those specified, the relay should be overhauled. Minor measures such as change of a plug-in-type PC board can be taken by normal service personnel with the required skill. In uncertain cases and if the fault is permanent the manufacturer or his nearest representative should be contacted for further information about checking, overhaul and recalibration of the relay. |
| | Should the temperature and humidity at the operating site differ from the values specified, or the atmosphere contain chemically active gases or dust, the relay should be visually inspected in association with the secondary testing of the relay. This visual inspection should focus on: <ul style="list-style-type: none"> - Signs of mechanical damage to relay case and terminals - Collection of dust inside the relay case; remove with compressed air - Signs of corrosion on terminals, case or inside the relay | <p>Note! The protection relay contains circuits that are sensitive to electrostatic discharge. If you have to withdraw a relay module, ensure that you are at the same potential as the module, for instance, by touching the case.</p> <p>Note! Static protective relays are measuring instruments and should be handled with care and protected against moisture and mechanical stress, especially during transport.</p> |

| | | | |
|---------------------------------|---------------------------------|-------------|----------------|
| Exchange and spare parts | Synchro-check relay module | SPCU 3D45 | RS 426 005 -AA |
| | Power and output relay module | | |
| | - $U_{aux} = 80...265$ V ac/dc | SPTU 240 R4 | RS 941 024 -AA |
| | - $U_{aux} = 18...80$ V dc | SPTU 48 R4 | RS 941 024 -BA |
| | Relay case including I/O module | SPTK 3E10 | |
| | I/O module, as a separate unit | SPTK 3E10 | |
| Bus connection module | SPA-ZC 17_ | | |
| Bus connection module | SPA-ZC 21_ | | |

| | | |
|----------------------|---|----------------------------|
| Order numbers | Synchro-check relay without test adapter SPAU 140 C | RS 488 001 -AA, CA, DA, FA |
| | Synchro-check relay with test adapter RTXP 18 SPAU 140 C | RS 488 201 -AA, CA, DA, FA |

The last two letters indicate the rated frequency f_n and the auxiliary voltage U_{aux} of the relay as follows:

- AA: $f_n = 50$ Hz and $U_{aux} = 80...265$ V ac/dc
- CA: $f_n = 50$ Hz and $U_{aux} = 18...80$ V dc
- DA: $f_n = 60$ Hz and $U_{aux} = 80...265$ V ac/dc
- FA: $f_n = 60$ Hz and $U_{aux} = 18...80$ V dc

| | | |
|-------------------------|----------------------|---|
| Order data | Type | Example |
| | 1. Quantity | 15 relays SPAU 140 C |
| | 2. Order number | RS 488 001 - AA |
| | 3. Rated frequency | $f_n = 50$ Hz |
| | 4. Auxiliary voltage | $U_{aux} = 110$ V dc |
| | 5. Accessories | 15 connection modules SPA-ZC 21 MM 30 fibre-optic cables SPA-ZF MM 100 |
| 6. Special requirements | – | |

Dimensions and instructions for mounting

The basic model of the protection relay case is designed for flush-mounting. When required, the mounting depth of the case can be reduced by means of raising frames: type SPA-ZX 111

reduces the depth by 40 mm, type SPA-ZX 112 by 80 mm and type SPA-ZX 113 by 120 mm. The type designation of the case for surface mounting is SPA-ZC 117.

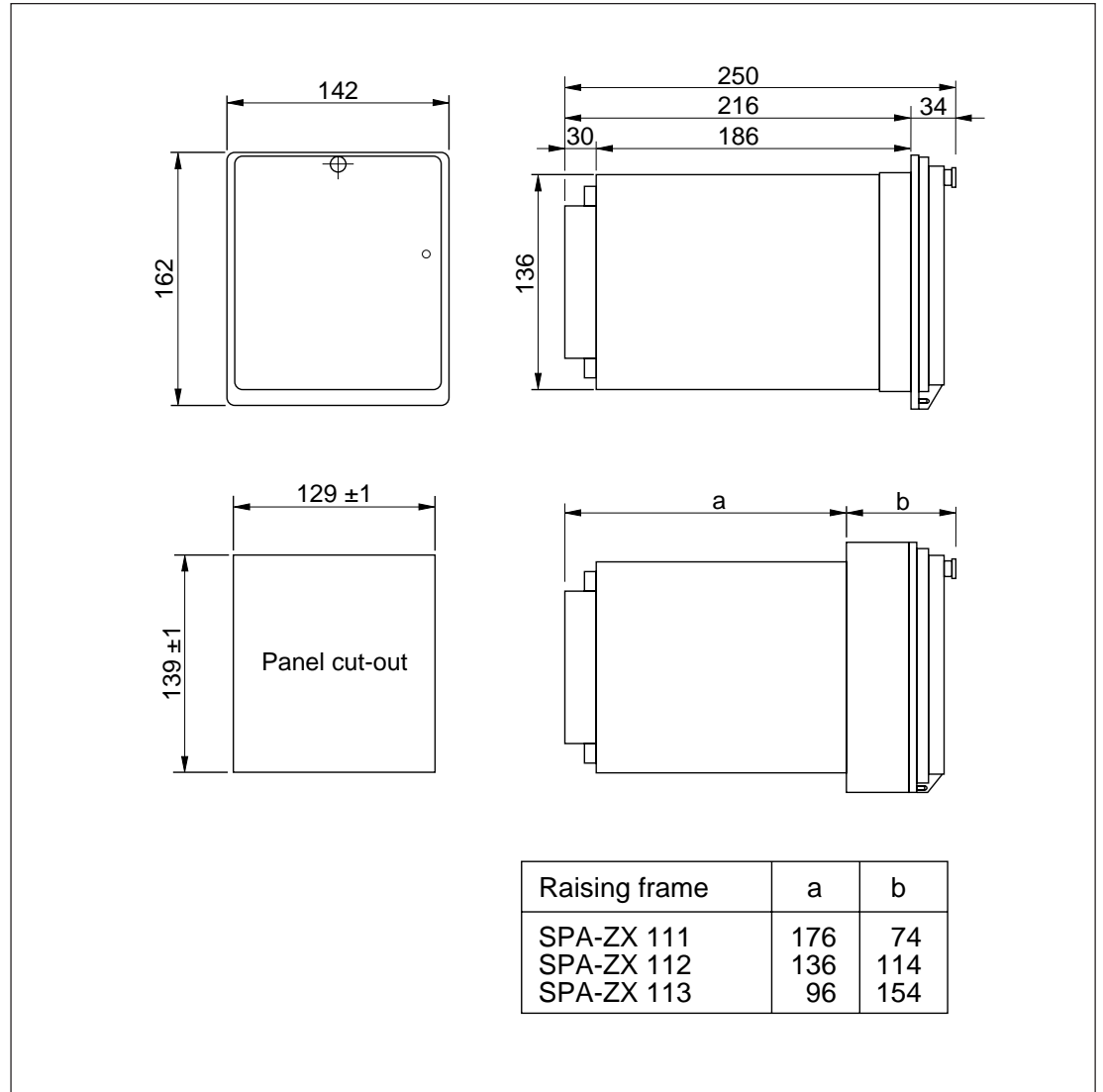

Fig. 7. Dimension and mounting drawings for synchro-check relay SPAU 140 C.

The relay case is made of anodized profile aluminium and finished in beige.

degree of protection between the case and the cover.

The rubber gasket fitted to the mounting collar provides an IP 54 degree of protection by enclosure between the relay case and the mounting base.

The required input and output wires are connected to the screw terminals on the rear panel. Each terminal screw is dimensioned for one wire of maximum 6 mm² or two wires of maximum 2.5 mm². Part of the control inputs is located in the detachable six-pole terminal block. The 9-pole D-type connector is intended for serial communication.

The hinged cover of the case is made of transparent, UV-stabilized polycarbonate polymer and provided with a sealable locking screw. The rubber gasket of the cover provides an IP 54

SPCU 3D45

Synchro-check relay module

User's manual and Technical description

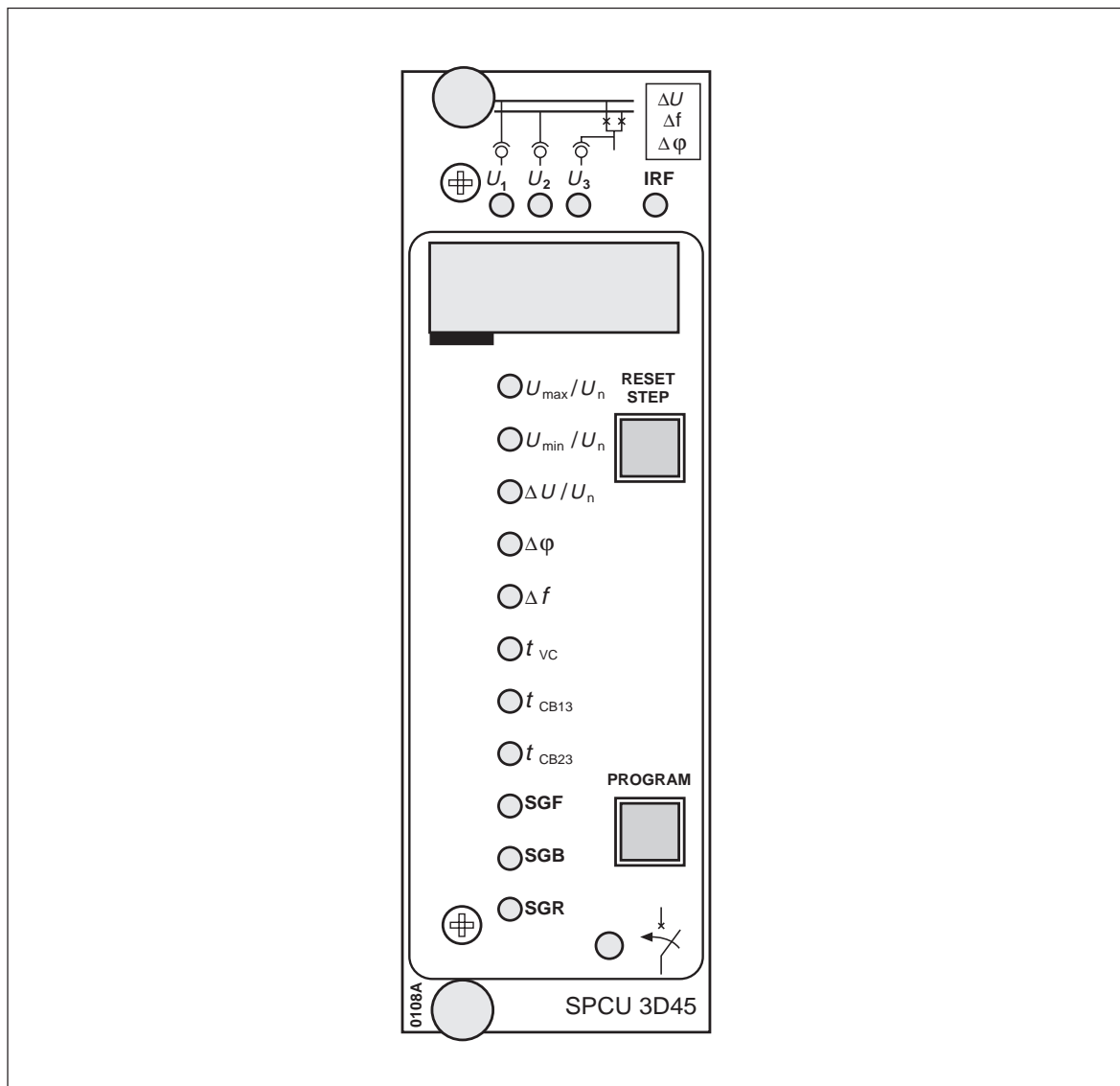

SPCU 3D45

Synchro-check relay module

Data subject to change without notice

Contents

| | |
|--|----|
| Features | 2 |
| Description of operation | 3 |
| Synchro-check function | 4 |
| Voltage-check function | 5 |
| Operation mode indicators | 6 |
| Description of operation mode | 6 |
| Continuous mode operation | 7 |
| Command mode operation | 8 |
| Block schematic diagram | 11 |
| Front panel | 13 |
| Operation indicators | 13 |
| Relay settings | 14 |
| Function selector switches | 15 |
| Measured data | 18 |
| Recorded information | 19 |
| Menu chart | 22 |
| Technical data | 24 |
| Serial communication parameters | 25 |
| Event codes | 25 |
| Data to be transferred over the serial bus | 27 |
| Fault codes | 32 |
| Calculation of the checksum | 32 |
| Test function | 33 |

Features

| | |
|---|--|
| Two identical operation stages allowing the closing conditions for two separate circuit breakers to be checked at the same time | Alarm from the command mode operation if the closing command attempt fails |
| Synchro-check function available in both operation stages for energized networks | Numerical display of setting values, measured values and values recorded on relay operation |
| Voltage-check function available in both operation stages for energized and non-energized networks | Setting values may be manually set by using push-buttons on the front panel or via the serial communication interface with a personal computer |
| Two different operation modes in both stages: continuous mode operation and command mode operation | Continuous self-supervision of both hardware and software of the relay with built-in auto-diagnosis |

Description of operation

The synchro-check module SPCU 3D45 includes two identical operation stages and both stages are provided with a synchro-check and a voltage-check function. The synchro-check relay module measures three different voltages: bus voltages U1 and U2 and line voltage U3. The operation stage 1 checks the closing conditions

between bus voltage U1 and line voltage U3 and operation stage 2 similarly checks the closing conditions between bus voltage U2 and line voltage U3. Figure 1 shows a simplified block diagram of the synchro-check module SPCU 3D45 with measured bus and line voltages and check functions.

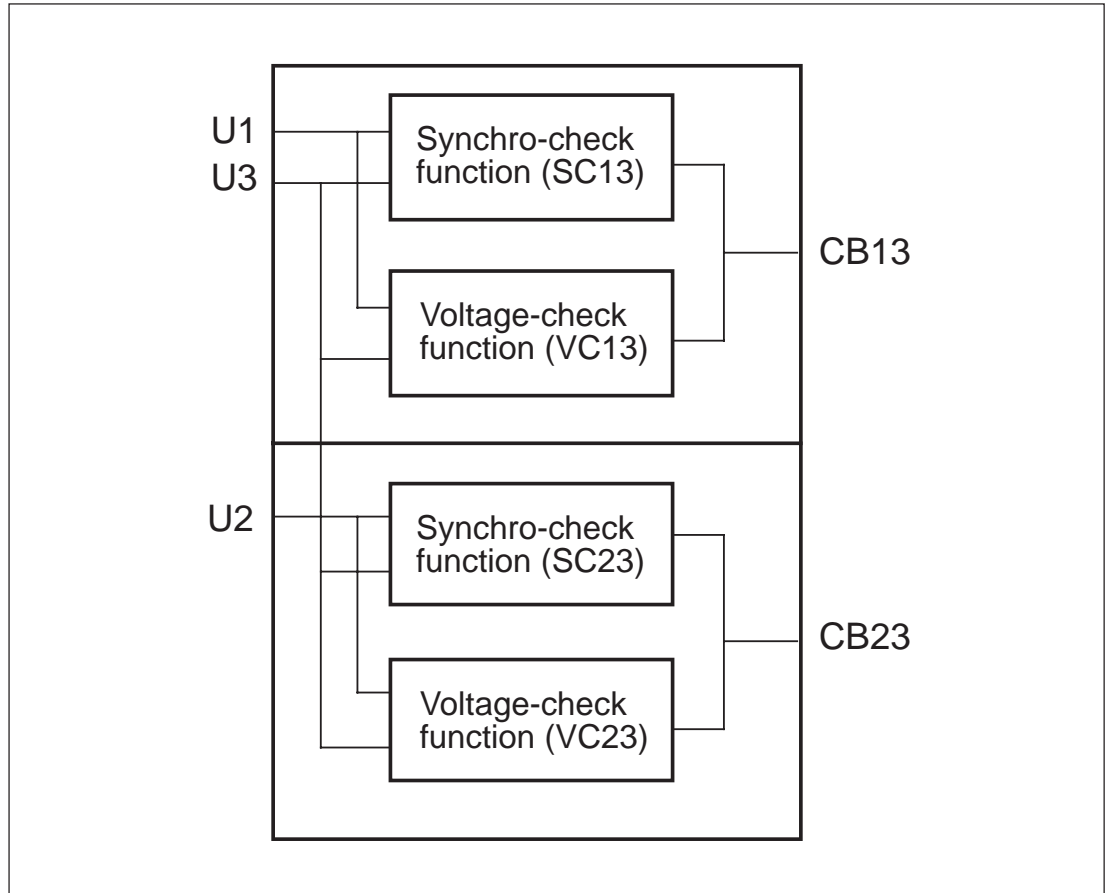

Fig. 1. A simplified block diagram of synchro-check module SPCU 3D45 and check functions.

Synchro-check function

The synchro-check function is used for checking whether CB closing is permitted or not. Before CB operation the following closing conditions must be fulfilled:

- The network sections on both sides of the CB must be energized. The voltage magnitudes of the energized networks are determined by the set value for the upper threshold voltage U_{max} .
- The voltage difference over the CB must be small enough. The voltage difference allowed is determined by the set voltage difference value ΔU .
- The frequencies of the network sections (voltages) to be connected shall not differ too much from each other. The frequency conditions are fulfilled when the allowed frequency difference of the networks to be connected is smaller than the set frequency difference value Δf .

- The network sections to be connected (voltages) have the same phase angle. The phase angle conditions are fulfilled when the allowed phase angle difference between the network voltages is smaller than the set phase angle difference $\Delta\phi$.
- The validity time t_{valid} for CB closing conditions, achieved from frequency and phase-angle differences must have a duration of at least the time needed for closing of the circuit breaker to be operated (operate time of CB).

When the closing conditions mentioned above are fulfilled simultaneously, the network voltages are considered to be synchronized and a closing command signal to the CB is delivered.

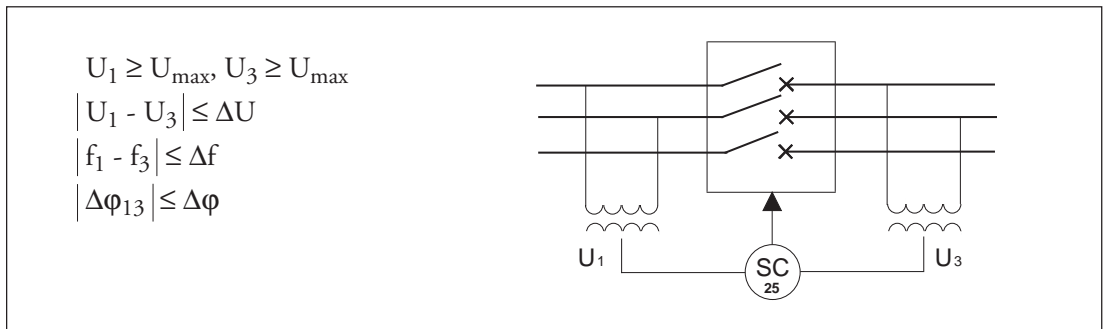

Fig. 2. Closing conditions to be checked according to the synchronism check scheme. The closing conditions for operation stage 2 are checked correspondingly between the voltages U2 and U3.

Settings for the synchro-check function

The threshold voltage U_{max} , above which the measured bus/line network voltage must be before the network is considered to be energized. The set threshold voltage value is the same for the synchro-check function of both stages.

- Voltage difference allowed, absolute value ΔU . The set value determines the maximum allowed voltage difference for the synchro-check function of both stages.
- Frequency difference allowed, absolute value Δf . The set value determines the maximum allowed frequency difference for the synchro-check function of both stages.
- The phase-angle difference allowed, $\Delta\phi$, is an absolute value which means that there are no demands concerning the phase-angle direction. The set value determines the maximum allowed phase-angle difference for the synchro-check function of both stages.

- Operate time of circuit breakers, t_{CB13} and t_{CB23} . The operate time of the circuit breaker controlled by a specific stage is separately set for the stage concerned. In applications, where the closing signal of the stage is not used directly for circuit breaker closing, but as a command signal to the control module CM, the total operate time for closing is set by calculating the operate time of the control module and the circuit breaker.

The operate time of the circuit breaker in the synchro-check function is used to assure that the closing conditions, especially at great frequency difference values, are fulfilled at the moment when the circuit breaker is to be closed.

- The synchro-check functions of the different stages are optional, i.e. these functions may be activated or set out of operation by means of function selector switches. The synchro-check function of stage 1 and stage 2 is activated or deactivated by means of switches SGF/3 and SGF/7, respectively; See chapter "Function selector switches".

Voltage-check function

The voltage-check function is required when a disconnected bus/line is to be connected to an energized section of a network. By means of the threshold voltages U_{\max} and U_{\min} of the synchro-check module, the threshold values for an energized or non-energized bus/line are set. Furthermore, the energizing direction is supervised by the voltage-check function. The energizing

direction of the module can be selected by means of function selector switches and the settings determine which side of the circuit breaker to be closed shall be energized or non-energized. For the voltage-check function the energizing direction of each stage can be selected from four different alternatives. The available energizing directions are as follows:

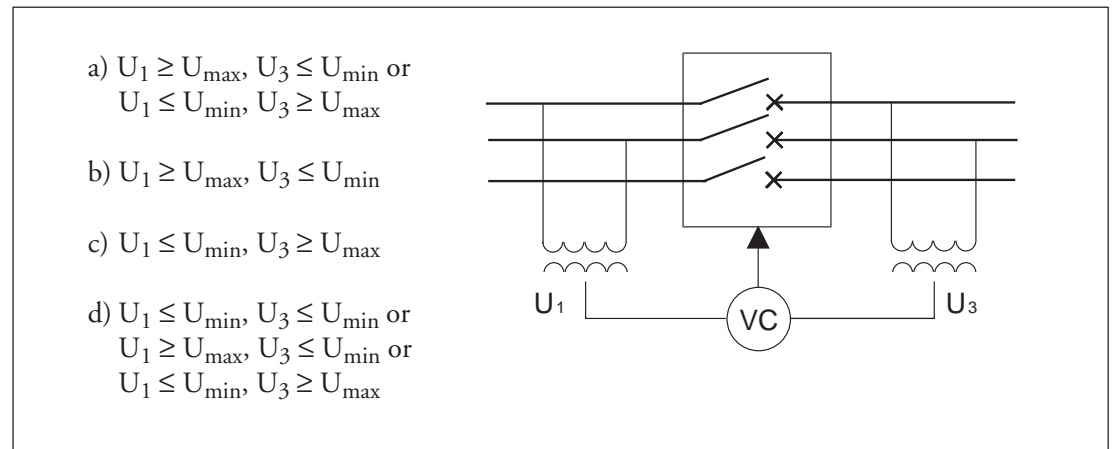

Fig. 3. Influence of voltage-check conditions on the delivering of a closing signal.

When the voltage-check conditions are fulfilled, they have to persist continuously for a pre-set operate time (dead time), before the releasing of a final closing signal is permitted. Thus, it is assured that the non-energized time of the network is long enough for releasing a closing sig-

nal and that it, is not caused by short-time voltage failures in the network sections. When the voltage-check conditions have been fulfilled long enough a closing signal is delivered to the circuit breaker.

Settings for the voltage-check function

- The threshold voltage U_{\max} , above which the measured bus/line network voltage must be before the network is considered to be energized. The set threshold voltage value is the same for the voltage-check function of both stages. The set threshold value applies to the synchro-check function as well.
- The threshold value U_{\min} , below which the measured bus/line network voltage must be before the network is considered to be non-energized. The set threshold voltage value is the same for the voltage-check function of both stages.

Note!

Because the setting ranges of the threshold voltages U_{\max} and U_{\min} partly overlap each other, the setting conditions may be such, that the setting of the non-energized threshold value U_{\min} is higher than the setting of the energized threshold value U_{\max} . The setting parameters should be done carefully by the user to avoid the setting conditions mentioned above.

- Operate time t_{VC} for the energizing operation (dead time). The set operate time applies to the voltage-check function of both stages.
- The energizing direction is separately selected by means of function selector switches for both voltage-check stages. The energizing direction of stage 1 is selected by means of switches SGF/1 and SGF/2 and the direction of stage 2 is selected with switches SGF/5 and SGF/6; See chapter "Function selector switches". For example, when the energizing direction of stage 1 is selected to be $U_1 \rightarrow U_3$ (SGF/1=1, SGF/2=0), the voltage U_1 shall be higher than U_{\max} and the voltage U_3 lower than U_{\min} before the conditions of the energizing direction are fulfilled.
- The voltage-check functions of the separate stages are optional, i.e. these functions may be activated or set out of operation by means of function selector switches. The voltage check function of stage 1 and stage 2 is activated or deactivated by means of switches SGF/4 and SGF/8, respectively; See chapter "Function selector switches".

Operation mode indicators

When a closing command for the circuit breaker is permitted, the synchro-check relay module activates the closing signals of one or both of the stages, that is, CB13 for stage 1 and CB23 for stage 2. Simultaneously, when one or both of the closing signals are active, a yellow LED indicator is lit in the bottom corner, to the right, on the front panel. The indicator remains on as long as the closing signals are active and goes out automatically when the closing signals re-

set. At the same time the digital display on the front panel indicates with a red digit 1 or 2 which stage has delivered the closing signal. The operation indicator on the display goes out automatically when the stage resets. In situations, where both stages are delivering closing signals simultaneously, the digital display always presents the last event, that is, the operation indicator on the display indicates the last activated closing signal and stage.

Description of operation mode

The closing command conditions for the circuit breaker are checked by the synchro-check and voltage-check functions. In addition to the closing command conditions the delivering of the final closing signal depends on the operation mode selected for the synchro-check relay. Selection of the operation mode depends on whether the synchro-check relay itself directly uses the output signal to close the circuit breaker (command mode operation) or if another device (for example a control module) performs the closing operation after having received a command signal from the synchro-check relay (continuous mode operation).

A distinctive difference between the operation modes is that in the command mode operation the synchro-check relay is controlled by an external command signal but in the continuous mode operation no external signal is needed. In the command mode operation the synchro-check relay delivers the closing signal directly to the object to be controlled (a circuit breaker) but in the continuous mode operation the closing signal is delivered via some other equipment which delivers the final closing signal.

The operation mode is selected separately for the operation stages: for stage 1 with switch SGB/3 and stage 2 with switch SGB/4.

Continuous mode operation

In the continuous mode operation the closing signal output of the synchro-check relay is active as long as the closing conditions are fulfilled and disappears when the conditions cease. The operation of the supervising stage can be blocked by applying a blocking signal to the stage. The function of the blocking input is selected by means of selector switchgroup SGB.

The activated output of the synchro-check relay delivers a command signal to the control module for the closing operation and the final closing operation is performed by the control

module. Beside the closing conditions in force, the only thing affecting the continuous mode operation is an external blocking signal applied to the synchro-check relay. When the blocking signal is activated the control output resets even if the closing conditions are valid. Should the blocking signal be active at the moment when the closing conditions come into force, no closing signal will be delivered. The principal realization of the closing operation system with the synchro-check relay in the continuous mode operation is presented in figure 4.

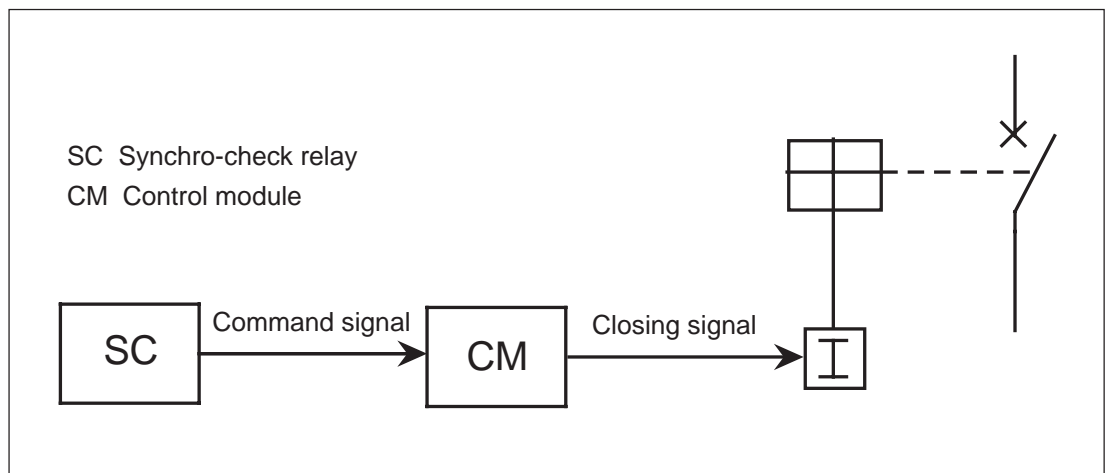

Fig. 4. A simplified block diagram of the synchro-check relay in continuous mode operation.

At great frequency differences the closing conditions are valid for a short time and the length of the closing signal pulse is becoming shorter and shorter with increasing frequency difference. The closing signal should be at least 70 ms, approximately, in the continuous mode operation.

Hence, time calculated from frequency and phase angle difference for valid closing conditions shall be about 70 ms longer than the operate time of the circuit breaker, before a closing signal is released.

Command mode operation

In command mode operation an external command signal, besides the normal closing conditions, is needed for delivering of the closing signal. The command signal shall be active as long as the set checking time. The closing signal from the supervision stage can be blocked by applying the blocking signal to the stage. The function of the blocking input is selected by means of selector switchgroup SGB.

In the command mode operation the synchro-check relay itself controls the selected object directly via its own output signal. In this case the control module delivers the command signal for closing to the synchro-check relay for releasing

of a closing signal pulse to the circuit breaker. If, after the delivered command signal for closing, the closing conditions are fulfilled during a permitted check time, the synchro-check relay delivers a closing signal to the circuit breaker. Via a possible feedback of the circuit breaker status the control module recognizes when the command signal can be removed. In such a case the duration of the command signal to be applied to the synchro-check relay is determined by the operate time of the circuit breaker. If feedback of the circuit breaker status is not available, the duration of the command signal from the control module is constant.

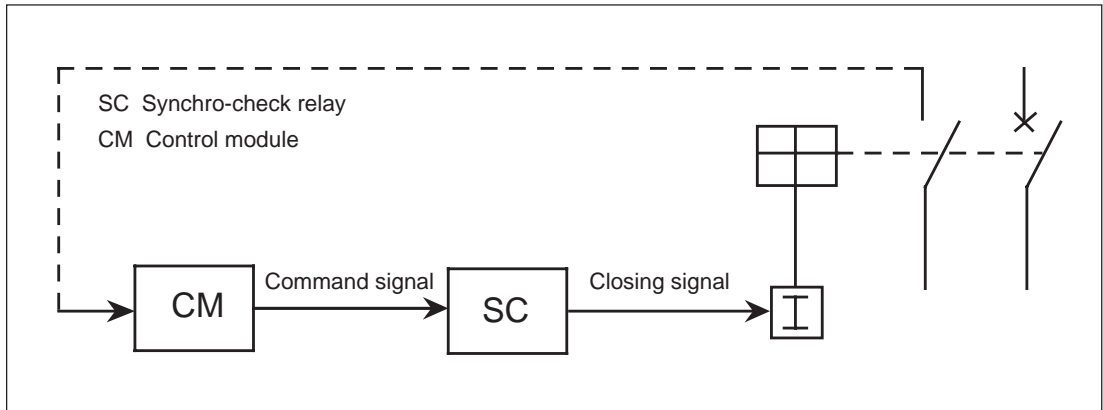

Fig. 5. A simplified block diagram of the synchro-check relay in command mode operation.

The closing signal in the command mode operation is pulse-shaped and the maximum length of the closing signal can be set. The closing signal is delivered only once per activated external closing command signal. The duration of the delivered closing signal is at least 100 ms, however, not longer than the set maximum parameter value. The minimum length of the signal depends on the duration of the delivered external command signal and the duration of the valid closing conditions. If the delivered command signal disappears or the closing conditions end before the maximum length of the command signal, the output resets and the closing signal will be shorter than the set parameter value, however, at least 100 ms. If the external closing command signal and the closing conditions persist longer than the length of the set closing signal, the closing signal will have the length of the set parameter value.

A valid time, after which the closing operation is going to be performed, is determined for the external closing command signal to be delivered. In that way a closing command sequence started can be limited to a certain length regardless of if the command signal, for example, stays

active due to a fault. The function of the command mode operation is such that it is possible to deliver an external alarm for divergent situations. In the command mode operation there are alarms for a failed closing attempt and for a command signal that remains active too long. If the command signal delivered to the supervising stage is too long, an alarm is given and the alarm state of the stage persists until the closing command signal is removed. A failed closing attempt produces an alarm signal of about 500 ms. After that the supervising stage is ready for a new operation sequence.

The most essential features of the command mode operation are shown in figures 6, 7 and 8.

Abbreviations used in the diagrams:

- cond13 Closing conditions for stage 1
- CS13 External closing command signal for stage 1
- BS13 External blocking input for stage 1
- CB13 Closing signal delivered by stage 1
- NC13 Alarm signal delivered by stage 1
- CSF13 Alarm signal delivered by stage 1

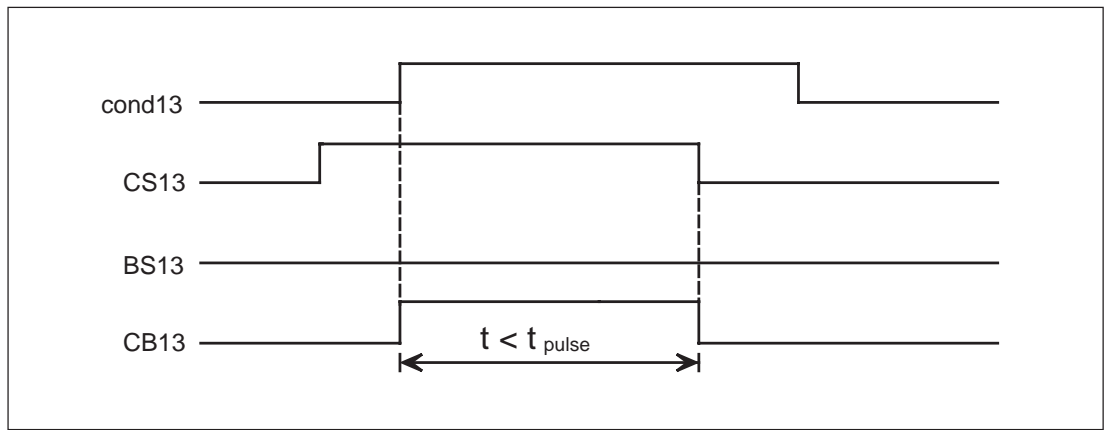

Fig. 6. Determination of the maximum length of the closing signal.

The maximum length of the closing signal is determined by the setting t_{pulse} . If the external command signal disappears during the closing operation the closing signal delivered from the stage also resets, however, in such a way that the closing signal is at least 100 ms, approxi-

mately. If the external command signal is active for a longer time than the setting value t_{pulse} , the closing signal resets after the set maximum time has elapsed. (Note! Alarm CSF13 in figure 7).

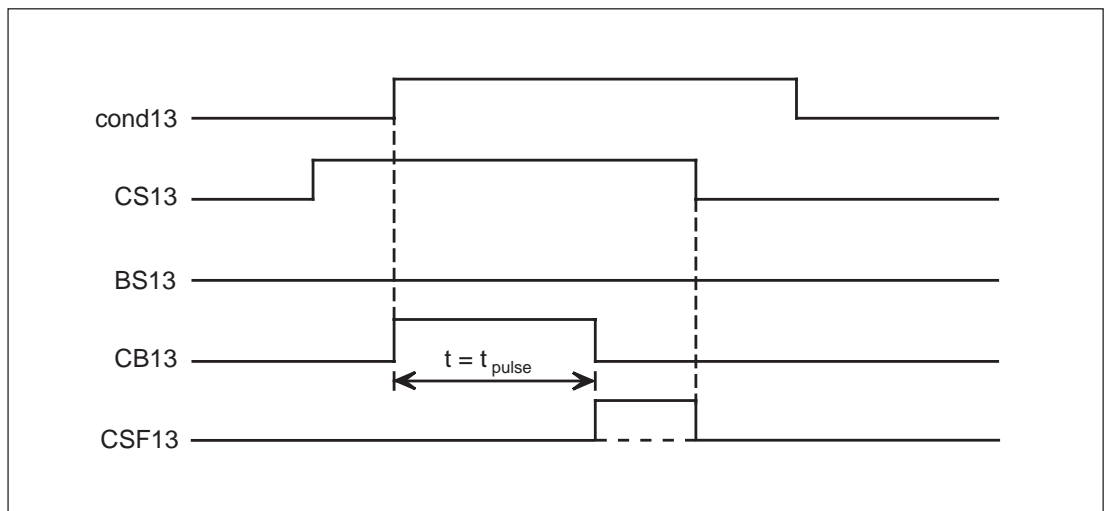

Fig. 7. Determination of the alarm limit for a still active command signal.

The setting of the pulse length can also be used for determining the alarm limit for a command signal that has remained active. The alarm is only important in systems according to figure 5, where the duration of the closing signal always is shorter than the set t_{pulse} time. The control module receives information about the circuit breaker status and thus is able to adjust the command signal to be delivered to the synchrocheck relay and at the same time the length of the closing signal. If the external command signal CS13 still is active when the closing signal resets after the set maximum t_{pulse} time, the

alarm CSF13 is activated. The alarm indicates that the control module has not removed the external command signal after the closing operation has been performed within the predetermined t_{pulse} time. When the duration of a standard external command signal constantly exceeds the maximum length of the set closing signal under normal closing conditions, the alarm shall be disconnected to avoid unnecessary alarms. The alarm can be enabled or disabled by means of the functional switchgroup SGR.

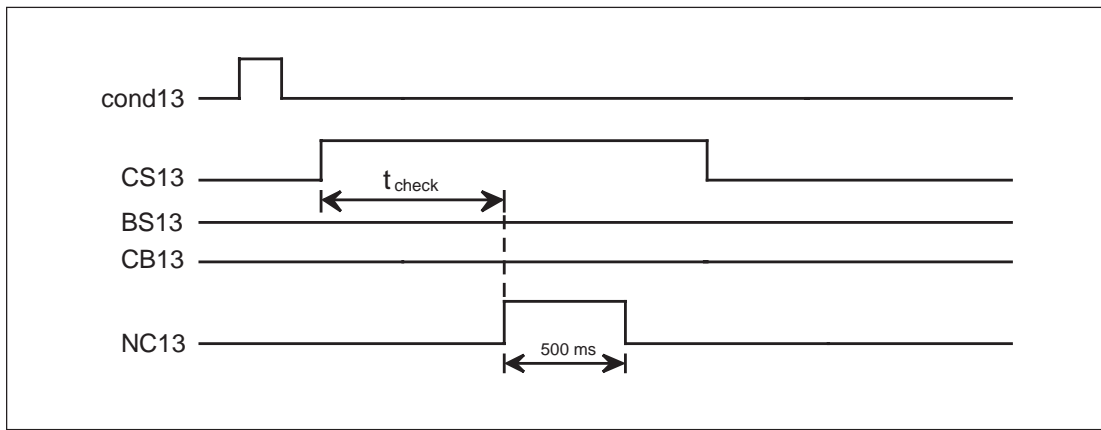

Fig. 8. Determination of the checking time for closing.

Closing is permitted during the time t_{check} starting from the moment when the external command signal CS13 is activated. The external command signal has to be active during the whole pre-set checking time, that is, when the length of the external command signal to be delivered to the supervision stage is determined, the value of the set t_{check} time must be considered too. If the closing command conditions get fulfilled during the t_{check} time, a closing signal is delivered to the circuit breaker. If the closing conditions are not fulfilled during the checking time, the alarm NC13 is activated for 500 ms as an indication of a failed closing attempt. If the closing conditions do not become valid until after the t_{check} time, no closing signal is

delivered. The closing signal is delivered only once per activated external command signal. A new closing command sequence cannot be started until the external command signal has been reset and then activated again.

By removing the external command signal too early the started closing command sequence can be interrupted and the supervision stage can be reset to original state. If the command signal CS13 is removed before the checking time t_{check} has elapsed and the closing operation has not been enabled, the sequence resets and no alarm of the failed closing attempt is delivered. The activation of the external command signal again starts a new checking sequence.

Settings for the command mode operation

The checking time t_{check} determines the time after which closing of the circuit breaker is permitted. The checking time starts after activation of the external command signal and the signal shall be active during the total checking time.

The maximum length of the closing signal in the command mode operation is determined by the set t_{pulse} time.

The closing signal may even be shorter depending on whether the external command signal delivered to the stage is removed before the set maximum t_{pulse} time has elapsed.

The alarms in the command mode operation are enabled or disabled by means of the functional switchgroup SGR.

Block schematic diagram

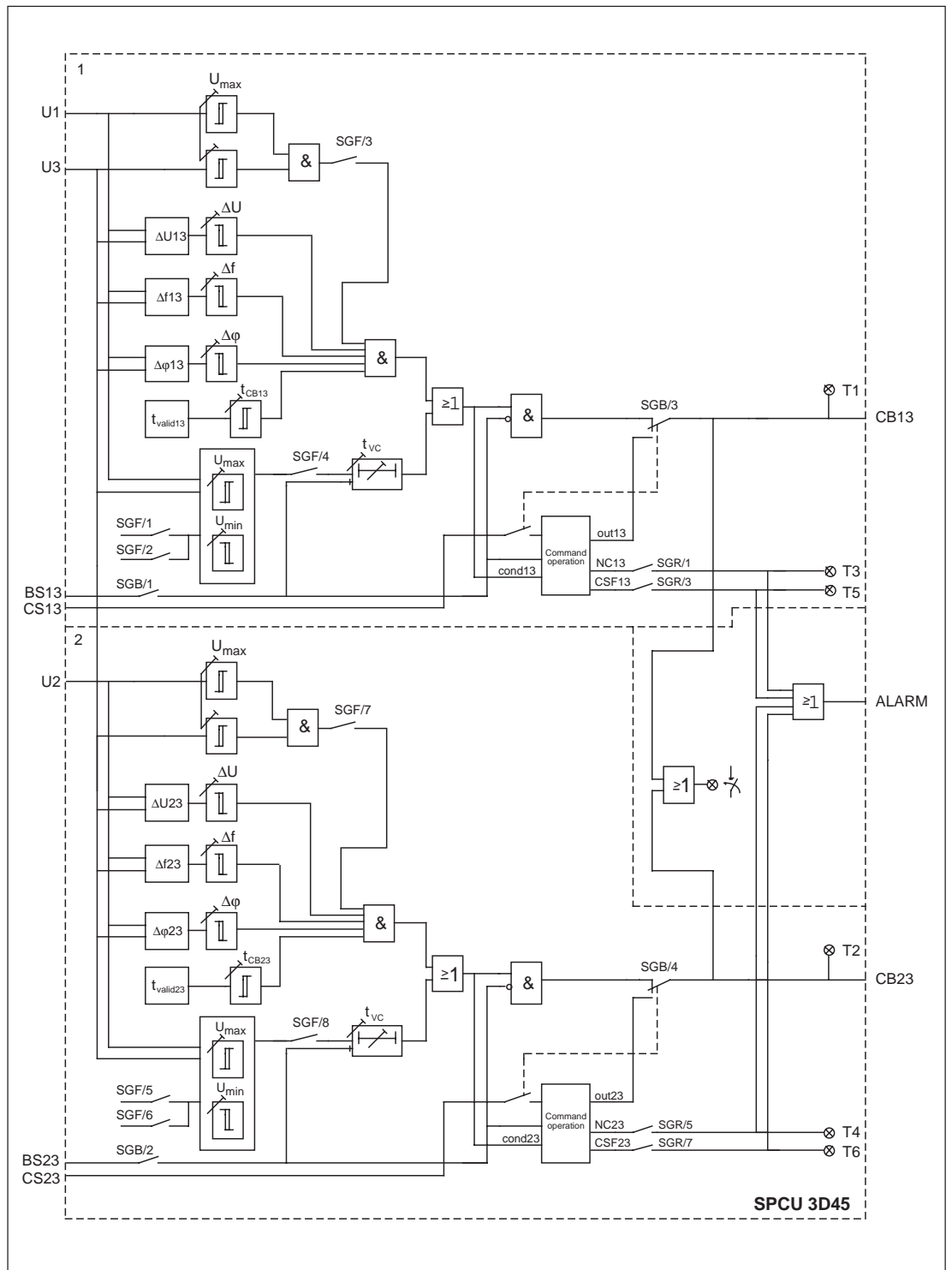

Fig. 9. Block schematic diagram for the synchro-check module SPCU 3D45.

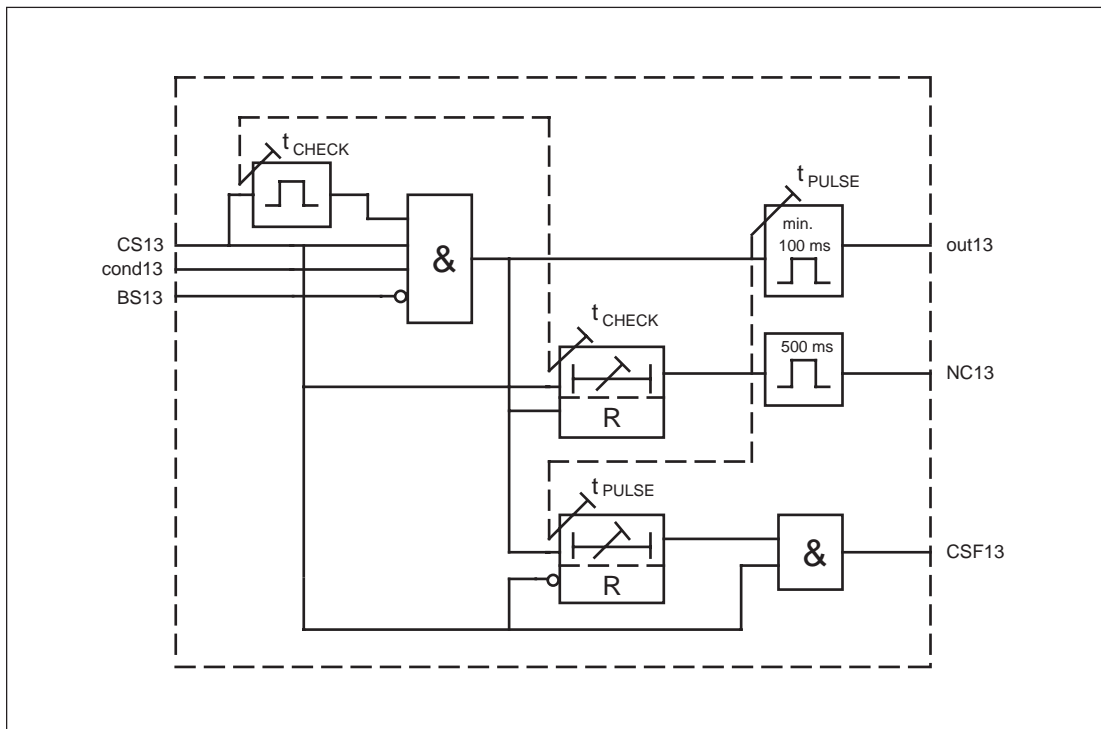



Fig. 10. A simplified block diagram for the command mode operation.

Abbreviations used in the block diagrams:

| | |
|---|---|
| U1, U2, U3 | Measured bus/line voltages |
| BS13 | External blocking signal for stage 1 |
| BS23 | External blocking signal for stage 2 |
| CS13 | External command signal for stage 1 |
| CS23 | External command signal for stage 2 |
| SGF | Functional switchgroup SGF |
| SGB | Functional switchgroup SGB |
| SGR | Functional switchgroup SGR |
| CB13 | Closing signal of stage 1 |
| CB23 | Closing signal of stage 2 |
| ALARM | Alarm signal output for stage 1 and 2 |
|  | Yellow LED indicator for closing operation |
| T1, T2, T3, T4, T5, T6 | Operation indicators indicated on the display |
| cond13 | Closing conditions for stage 1 |
| cond 23 | Closing conditions for stage 2 |
| out13 | Output signal from stage 1 in command mode operation |
| out23 | Output signal from stage 2 in command mode operation |
| NC13 | Alarm for failed closing attempt from stage 1 |
| NC23 | Alarm for failed closing attempt from stage 2 |
| CSF13 | Alarm for too long a command signal CS13 from stage 1 |
| CSF23 | Alarm for too long a command signal CS23 from stage 2 |

Note!

All input and output signals from the synchro-check module are not necessarily wired to the terminals of every relay assembly using this module. The signals wired to the terminals of

the relay are shown in the diagram illustrating the signal flow between the plug-in modules of the relay assembly.

Front panel

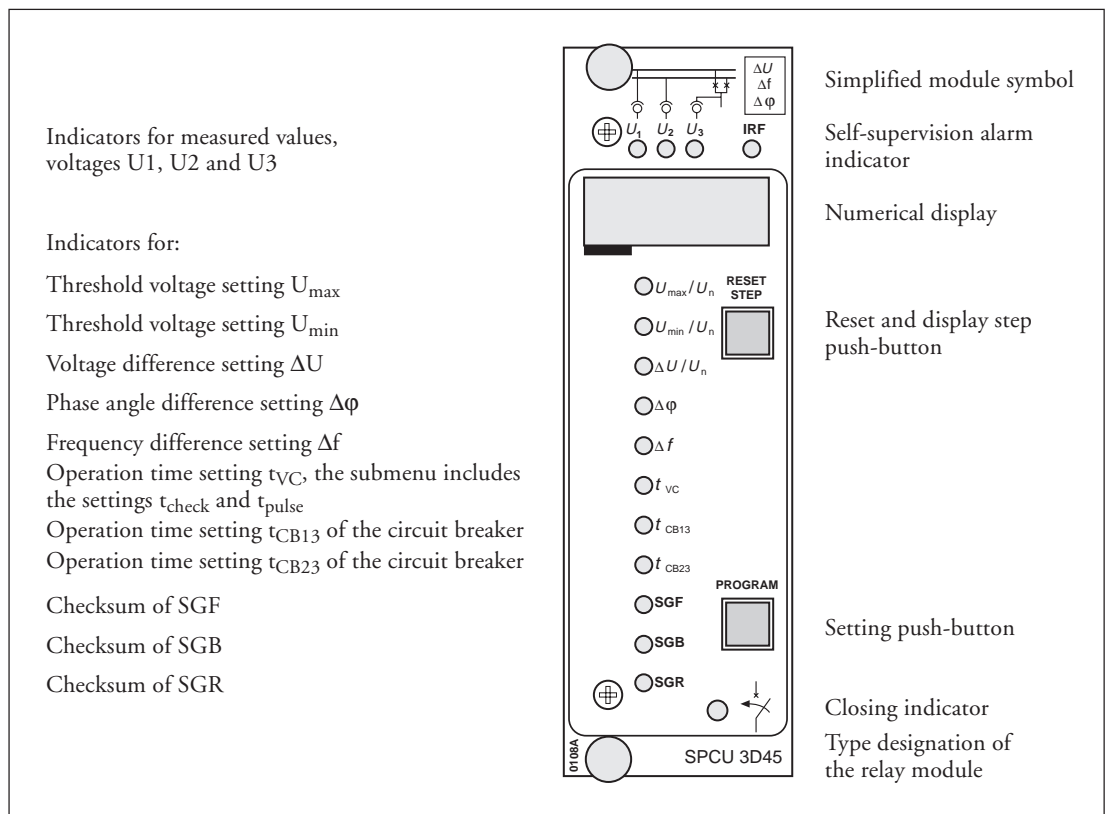

Fig.11. Front panel of the synchro-check module type SPCU 3D45.

Operation indicators

Both stages have their own operation indicators shown as a number on the digital display. Further both stages have a common LED operation indicator glowing yellow when the module has delivered a closing signal. The indicator for closing is lit only when the closing signal is active.

Together with the LED operation indicator a red operation number 1 or 2 on the display is indicating which stage has activated the closing signal. The operation indicator and the operation number on the display are automatically

switched off when the stage resets. The alarm numbers 3, 4, 5 and 6 remain lit on the display when the alarm situation resets. The alarm numbers are acknowledged by the RESET/STEP push-button. An operation indicator that has not been acknowledged has no influence on the relay module operation and the module is continuously ready for operation.

The following table shows the operation indications with explanations used in the synchro-check relay module.

| Operation indication | Explanation |
|----------------------|--|
| 1 | CB13 Active closing signal CB13 from stage 1 to the CB |
| 2 | CB23 Active closing signal CB23 from stage 2 to the CB |
| 3 | NC13 Failed CB closing attempt from stage 1 (command mode operation) |
| 4 | NC23 Failed CB closing attempt from stage 2 (command mode operation) |
| 5 | CSF13 Alarm of external command signal CS13 (command mode operation) |
| 6 | CSF23 Alarm of external command signal CS23 (command mode operation) |

The self-supervision alarm indicator IRF indicates that the self-supervision system has detected a permanent fault. The red LED indicator is lit about one minute after the fault has been detected. At the same time the plug-in module delivers a signal to the output relay of the self-supervision system in the protection

relay assembly. Additionally, in most cases, a fault code showing the nature of the fault appears on the display of the module. The fault code consists of a red digit one and a green code number. When a fault occurs, the fault code should be recorded and stated when service is ordered.

Relay settings

The setting values are shown by the right-most three digits of the display. An indicator close to the setting value symbol shows when illuminated which setting value is shown on the display at the very moment. All setting parameters except the operation time of the circuit breaker are common to both stages.

play at the very moment. All setting parameters except the operation time of the circuit breaker are common to both stages.

| Setting | Parameter | Setting range | Default values |
|--------------------|--|---|-------------------|
| U_{\max}/U_n | Upper threshold voltage level above which the measured bus/line voltage is considered to be energized. | $0.5 \dots 1.0 \times U_n$ | $0.5 \times U_n$ |
| U_{\min}/U_n | Lower threshold voltage level below which the measured bus/line voltage is considered to be de-energized. | $0.1 \dots 0.8 \times U_n$ step $0.01 \times U_n$ | $0.1 \times U_n$ |
| $\Delta U/U_n$ | Max. difference allowed in bus/line voltage magnitude | $0.02 \dots 0.4 \times U_n$ step $0.01 \times U_n$ | $0.02 \times U_n$ |
| $\Delta \varphi$ | Max. phase angle difference allowed in bus/line voltage | $5 \dots 50^\circ$ step 1° | 5° |
| Δf | Max. frequency difference allowed in bus/line voltage | $0.02 \dots 0.5 \text{ Hz}$ step 0.01 Hz | 0.02 Hz |
| t_{vc} | Operate time (dead time) of the voltage-check function | $0.1 \dots 20 \text{ s}$ step 0.01 s | 0.1 s |
| t_{check} | Checking time allowed for closing operation in command mode operation (submenu of t_{vc}) | $0.05 \dots 300 \text{ s}$ step 0.01 s | 0.05 s |
| t_{pulse} | Maximum length of closing signal in command mode operation (submenu of t_{vc}) | $0.2 \dots 20 \text{ s}$ step 0.02 | 0.2 s |
| t_{CB13} | Operate time of circuit breaker operated by stage 1 Note! When the display shows the indication " - - - ", it indicates that the synchro-check and voltage-check functions of stage 1 are set out of operation by means of the functional switchgroup SGF. | $0.05 \dots 0.25 \text{ s}$ step 0.01 s | 0.05 s |
| t_{CB23} | Operate time of circuit breaker operated by stage 2 Note! When the display shows " - - - ", it indicates that the synchro-check and voltage-check functions of stage 2 are set out of operation by means of the functional switchgroup SGF. | $0.05 \dots 0.25 \text{ s}$ step 0.01 s | 0.05 s |

Further, the checksums of the function selector switchgroups SGF, SGB and SGR are indicated on the display when the indicators adjacent to the switch group symbols on the front panel are lit. The function of each selector switch in the relay is separately explained in the chapter

" Function selector switches". Further, see section "Main menus and submenus of settings and registers". An example of calculating the checksum is given in the general description of the D-type SPC relay modules.

Function selector switches

Additional functions required by individual applications are selected by means of switchgroups SGF, SGB and SGR indicated on the front panel. The numbering of the switches, i.e., 1...8, and the switch positions 0 and 1, are in-

dicated when the switches are set. Under normal service only the checksums are shown on the display. The switchgroups SGF, SGB and SGR are software-based and thus not to be found in the hardware of the relay module.

Functional switchgroup SGF

| Switch | Function | Factory defaults | | | | | | | | | | | | | | | |
|----------------|--|---------------------------------------|-------|----------------------|---|---|---------------------------------------|---|---|-------|---|---|-------|---|---|----------------|--------|
| SGF/1 SGF/2 | Selection of energizing direction for stage 1 in the voltage-check function. <table border="1" data-bbox="539 434 1385 654"> <thead> <tr> <th>SGF/1</th> <th>SGF/2</th> <th>Energizing direction</th> </tr> </thead> <tbody> <tr> <td>0</td> <td>0</td> <td>Both "de-energized" or U1→U3 or U1←U3</td> </tr> <tr> <td>1</td> <td>0</td> <td>U1→U3</td> </tr> <tr> <td>0</td> <td>1</td> <td>U1←U3</td> </tr> <tr> <td>1</td> <td>1</td> <td>U1→U3 or U1←U3</td> </tr> </tbody> </table> | SGF/1 | SGF/2 | Energizing direction | 0 | 0 | Both "de-energized" or U1→U3 or U1←U3 | 1 | 0 | U1→U3 | 0 | 1 | U1←U3 | 1 | 1 | U1→U3 or U1←U3 | 1 1 |
| SGF/1 | SGF/2 | Energizing direction | | | | | | | | | | | | | | | |
| 0 | 0 | Both "de-energized" or U1→U3 or U1←U3 | | | | | | | | | | | | | | | |
| 1 | 0 | U1→U3 | | | | | | | | | | | | | | | |
| 0 | 1 | U1←U3 | | | | | | | | | | | | | | | |
| 1 | 1 | U1→U3 or U1←U3 | | | | | | | | | | | | | | | |
| SGF/3 | Selection of synchro-check function of stage 1. When SGF/3=1, the synchro-check function is enabled. When SGF/3=0, the synchro-check function is disabled. | 0 | | | | | | | | | | | | | | | |
| SGF/4 | Selection of voltage-check function of stage 1. When SGF/4=1, the voltage-check function is enabled. When SGF/4=0, the voltage-check function is disabled. | 0 | | | | | | | | | | | | | | | |
| SGF/5 SGF/6 | Selection of energizing direction for stage 2 in the voltage-check function. <table border="1" data-bbox="539 1070 1385 1290"> <thead> <tr> <th>SGF/5</th> <th>SGF/6</th> <th>Energizing direction</th> </tr> </thead> <tbody> <tr> <td>0</td> <td>0</td> <td>Both "de-energized" or U2→U3 or U2←U3</td> </tr> <tr> <td>1</td> <td>0</td> <td>U2→U3</td> </tr> <tr> <td>0</td> <td>1</td> <td>U2←U3</td> </tr> <tr> <td>1</td> <td>1</td> <td>U2→U3 or U2←U3</td> </tr> </tbody> </table> | SGF/5 | SGF/6 | Energizing direction | 0 | 0 | Both "de-energized" or U2→U3 or U2←U3 | 1 | 0 | U2→U3 | 0 | 1 | U2←U3 | 1 | 1 | U2→U3 or U2←U3 | 1 1 |
| SGF/5 | SGF/6 | Energizing direction | | | | | | | | | | | | | | | |
| 0 | 0 | Both "de-energized" or U2→U3 or U2←U3 | | | | | | | | | | | | | | | |
| 1 | 0 | U2→U3 | | | | | | | | | | | | | | | |
| 0 | 1 | U2←U3 | | | | | | | | | | | | | | | |
| 1 | 1 | U2→U3 or U2←U3 | | | | | | | | | | | | | | | |
| SGF/7 | Selection of synchro-check function of stage 2. When SGF/7=1, the synchro-check function is enabled. When SGF/7=0, the synchro-check function is disabled. | 0 | | | | | | | | | | | | | | | |
| SGF/8 | Selection of voltage check function of stage 2. When SGF/8=1, the voltage-check function is enabled. When SGF/8=0, the voltage-check function is disabled. | 0 | | | | | | | | | | | | | | | |
| Σ | Checksum for factory setting | 51 | | | | | | | | | | | | | | | |

| Switch | Function | Factory defaults |
|----------|---|------------------|
| SGB/1 | Selection of the external blocking signal for stage 1. When SGB/1=1, stage 1 is blocked by the input signal BS13. When SGB/1=0, stage 1 is not blocked by the input signal BS13. | 0 |
| SGB/2 | Selection of the external blocking signal for stage 2. When SGB/2=1, stage 2 is blocked by the input signal BS23. When SGB/2=0, stage 2 is not blocked by the input signal BS23. | 0 |
| SGB/3 | Selection of operation mode for stage 1. When SGB/3=1, command mode operation is selected for stage 1. Stage 1 does not close the circuit breaker until the closing conditions are fulfilled and the external command signal CS13 is active. When SGB/3=0, continuous mode operation is selected for stage 1. Stage 1 delivers the closing signal CB13 when the closing conditions for the circuit breaker are fulfilled. | 0 |
| SGB/4 | Selection of operation mode for stage 2. When SGB/4=1, command mode operation is selected for stage 2. Stage 2 does not close the circuit breaker until the closing conditions are fulfilled and the external command signal CS23 is active. When SGB/4=0, continuous mode operation is selected for stage 2. Stage 2 delivers the closing signal CB23 when the closing conditions for the circuit breaker are fulfilled. | 0 |
| SGB/5 | Switch is not in use. The switch should be in position 0. | 0 |
| SGB/6 | Switch is not in use. The switch should be in position 0. | 0 |
| SGB/7 | Switch is not in use. The switch should be in position 0. | 0 |
| SGB/8 | Switch is not in use. The switch should be in position 0. | 0 |
| Σ | Checksum for factory setting | 0 |

Output relay switch-group SGR for alarm signals

The alarms required in command mode operation are selected by means of switchgroup SGR.

All alarm signals are delivered to the common output relay ALARM.

| Switch | Function | Factory defaults |
|--------|--|------------------|
| SGR/1 | When SGR/1=1, the alarm signal NC13 of stage 1 for a failed CB closing is delivered to the output relay ALARM and the corresponding operation figure is indicated on the display. When SGR/1=0, the alarm signal NC13 is blocked. | 0 |
| SGR/2 | Switch is not in use. The switch should be in position 0. | 0 |
| SGR/3 | When SGR/3=1, the alarm signal CSF13 of stage 1 for too long a command signal CS13 is delivered to the output relay ALARM and the corresponding operation figure is indicated on the display. When SGR/3=0, the alarm signal CSF13 is blocked. | 0 |
| SGR/4 | Switch is not in use. The switch should be in position 0. | 0 |
| SGR/5 | When SGR/5=1, the alarm signal NC23 of stage 2 for a failed CB closing is delivered to the output relay ALARM and the corresponding operation figure is indicated on the display. When SGR/5=0, the alarm signal NC23 is blocked. | 0 |
| SGR/6 | Switch is not in use. The switch should be in position 0. | 0 |
| SGR/7 | When SGR/7=1, the alarm signal CSF23 of stage 2 for excessive duration of the command signal CS23 is delivered to the output relay ALARM and the corresponding operation figure is indicated on the display. When SGR/7=0, the alarm signal CSF23 is blocked. | 0 |
| SGR/8 | Switch is not in use. The switch should be in position 0. | 0 |
| Σ | Checksum for factory setting | 0 |

Measured data

The measured values are displayed by the three right-most digits of the display. The currently displayed value is indicated by an illuminated LED indicator on the front panel of the relay.

| Indicator | Measured value |
|-----------|--|
| U1 | <p>Bus voltage U1 as a multiple of the rated voltage U_n.</p> <p>Submenu 1: Voltage difference between voltages U1 and U3 ($U1-U3$) as a multiple of the rated voltage U_n.</p> <p>Submenu 2: Frequency difference between voltages U1 and U3. The sign indication of the frequency difference is shown on the display as follows:</p> <p>No sign $f_{U1} > f_{U3}$ " - " $f_{U1} < f_{U3}$</p> <p>Submenu 3: Phase angle difference between voltages U1 and U3. The sign indication of the phase angle difference is shown on the display as follows:</p> <p>No sign U1 leads U3 " - " U1 lags U3</p> <p>Note! The red submenu digit 1, 2 or 3 is substituted by a minus sign (" - ") if the voltage, frequency or phase angle difference is negative.</p> |
| U2 | <p>Bus voltage U2 as a multiple of the rated voltage U_n.</p> <p>Submenu 1: Voltage difference between voltages U2 and U3 ($U2-U3$) as a multiple of the rated voltage U_n.</p> <p>Submenu 2: Frequency difference between voltages U2 and U3. The sign indication of the frequency difference is shown on the display as follows:</p> <p>No sign $f_{U2} > f_{U3}$ " - " $f_{U2} < f_{U3}$</p> <p>Submenu 3: Phase angle difference between voltages U2 and U3. The sign indication of the phase angle difference is shown on the display as follows:</p> <p>No sign U2 leads U3 " - " U2 lags U3</p> <p>Note! The red submenu digit 1, 2 or 3 is substituted by a minus sign (" - ") if the voltage, frequency or phase angle difference is negative.</p> |
| U3 | <p>Line voltage U3 as a multiple of the rated voltage U_n.</p> <p>Submenu 1: Frequency value of voltage U3</p> |

Recorded information

The left-most digit on the display shows the address of the register and the other three digits indicate the parameter value recorded. The configuration of the registers is illustrated in the chapter "Main menus and submenus of settings and registers".

The registers are updated once a stage of the module starts and operates. Then the previous values are moved one step forward in the register and a new value is added to the memory stack. At a maximum five values are recorded in the memory and if a sixth starting or operation occurs, the oldest value will be lost.

| Register | Data recorded |
|----------|--|
| 1 | <p>Bus voltage U1 as a multiple of the rated voltage U_n. If the closing operation is performed by stage 2, the readout " - - - " is stored in a memory.</p> <p>Submenus 1...4: Bus voltage value U1 at closing operation events (n-1)...(n-4).</p> |
| 2 | <p>Bus voltage U2 as a multiple of the rated voltage U_n. If the closing operation is performed by stage 1, the readout " - - - " is stored in a memory.</p> <p>Submenus 1...4: Bus voltage value U2 at closing operation events (n-1)...(n-4).</p> |
| 3 | <p>Line voltage U3 as a multiple of the rated voltage U_n. Every closing operation is stored in a memory.</p> <p>Submenus 1...4: Line voltage value U3 at closing operation events (n-1)...(n-4).</p> |
| 4 | <p>Phase angle difference between voltages U1 and U3. If the closing operation is performed by the synchro-/voltage check function of stage 2 or the voltage check function of stage 1, the readout " - - - " is stored in a memory.</p> <p>Submenus 1...4: Phase angle difference value $\Delta\phi_{13}$ at the closing operation events (n-1)...(n-4).</p> |
| 5 | <p>Phase angle difference between voltages U2 and U3. If the closing operation is performed by the synchro-/voltage-check function of stage 1 or the voltage-check function of stage 2, the readout " - - - " is stored in a memory.</p> <p>Submenus 1...4: Phase angle difference value $\Delta\phi_{23}$ at the closing operation events (n-1)...(n-4).</p> |
| 6 | <p>Frequency of line voltage U3 at closing operation.</p> <p>Submenus 1...4: Frequency value f_3 at closing operation events (n...1)...(n-4). Submenu 5: Number of closing operations of the synchro-check function of stage 1.</p> |
| 7 | <p>Frequency difference between voltages U1 and U3. If the closing operation is performed by the synchro-/voltage-check function of stage 2 or the voltage-check function of stage 1, the readout " - - - " is stored in a memory.</p> <p>Submenus 1...4: Frequency difference value Δf_{13} at closing operation events (n...1)...(n-4). Submenu 5: Number of closing operations of the voltage check function of stage 1.</p> |
| 8 | <p>Frequency difference between voltages U2 and U3. If the closing operation is performed by the synchro-/voltage-check function of stage 1 or the voltage-check function of stage 2, the readout " - - - " is stored in a memory.</p> <p>Submenus 1...4: Frequency difference value Δf_{23} at closing operation events (n...1)...(n-4). Submenu 5: Number of closing operations of the synchro-check function of stage 2.</p> |

| Register | Data recorded |
|----------|--|
| 9 | <p>Stage which performed the closing operation. Stage and checking functions are stored in a memory with an operation mode number as follows: 1 = The synchro-check function of stage 1 performed the closing operation 2 = The voltage check function of stage 1 performed the closing operation 4 = The synchro-check function of stage 2 performed the closing operation 8 = The voltage check function of stage 2 performed the closing operation</p> <p>Submenus 1...4: Mode numbers of closing operation events (n-1)...(n-4). Submenu 5: Number of closing operations of the voltage-check function for stage 1.</p> |
| 0 | <p>Display of closing conditions fulfilled by the module stages</p> <p>The right-most green digit indicates the closing conditions for stage 1 and the middlemost digit indicates the corresponding closing conditions for stage 2. The closing conditions fulfilled are presented as follows:</p> <ul style="list-style-type: none"> - No closing conditions fulfilled. 5 All voltage-check conditions are fulfilled. 4 The threshold voltage U_{max} in the synchro-check function is valid. * The network voltages are above the set threshold voltage value U_{max}. 3 The voltage difference is less than the set value ΔU. 2 The frequency difference is less than the set value Δf, the closing conditions 4 and 3 are also valid. 1 The phase angle difference is less than the set value $\Delta\phi$, the closing conditions 4, 3 and 2 are also valid. 0 All closing conditions in the synchro-check function are fulfilled. The operate time of the circuit breaker is shorter than the valid time for the closing conditions calculated from the frequency and phase angle difference. <p>The relation between frequency and phase angle difference is as follows: $t_{validx3} = \Delta\phi / (180^\circ * \Delta f)$ and $t_{validx3} > t_{CBx3}$</p> <p>$t_{validx3}$: valid time for closing conditions. The length of the closing signal in continuous mode operation should be at least 70 ms, approximately. Thus, the $t_{validx3}$ time must be about 70 ms longer than the operating time of the circuit breaker before a closing signal is delivered. t_{CBx3}: operate time of the circuit breaker to be controlled.</p> <p>Submenu: Display of blocking and command signals</p> <p>The right-most green digit of the submenu display indicates the state of the blocking inputs of the synchro-check module. The blocking input states are indicated as follows:</p> <ul style="list-style-type: none"> 0 = no blocking signals 1 = the blocking signal BS13 is active 2 = the blocking signal BS23 is active 3 = both blocking signals are active <p>The middle green digit of the submenu display indicates the state of the command inputs of the synchro-check module. The command input states are indicated as follows:</p> <ul style="list-style-type: none"> 0 = no command signals 1 = the command signal CS13 is active 2 = the command signal CS 23 is active 3 = both command signals are active <p>The effect of the external command signals on the relay is determined by the setting of switchgroup SGB.</p> |

| Register | Data recorded | | | | | | | | | | | | | | |
|--|---|----------------------|----------------------|----------------|---------------------|----------------|---------------------|----------------|-------------------|--------------|--------------------|------------|-------------------|----------|--------------------|
| A | <p>From the submenu of register 0 it is possible to enter on to the TEST mode, where the closing and alarm signals of the synchro-check module are tested and indicated by a flashing LED one by one.</p> <p>Note! The closing conditions are not checked in the TEST mode.</p> <table border="0"> <tr> <td>No indication</td> <td>Self-supervision IRF</td> </tr> <tr> <td>U_{\max}/U_n</td> <td>Closing signal CB13</td> </tr> <tr> <td>U_{\min}/U_n</td> <td>Closing signal CB23</td> </tr> <tr> <td>$\Delta U/U_n$</td> <td>Alarm signal NC13</td> </tr> <tr> <td>$\Delta\phi$</td> <td>Alarm signal CSF13</td> </tr> <tr> <td>Δf</td> <td>Alarm signal NC23</td> </tr> <tr> <td>t_{VC}</td> <td>Alarm signal CSF23</td> </tr> </table> <p>For further details see the description "Test function" in the manual.</p> | No indication | Self-supervision IRF | U_{\max}/U_n | Closing signal CB13 | U_{\min}/U_n | Closing signal CB23 | $\Delta U/U_n$ | Alarm signal NC13 | $\Delta\phi$ | Alarm signal CSF13 | Δf | Alarm signal NC23 | t_{VC} | Alarm signal CSF23 |
| | No indication | Self-supervision IRF | | | | | | | | | | | | | |
| U_{\max}/U_n | Closing signal CB13 | | | | | | | | | | | | | | |
| U_{\min}/U_n | Closing signal CB23 | | | | | | | | | | | | | | |
| $\Delta U/U_n$ | Alarm signal NC13 | | | | | | | | | | | | | | |
| $\Delta\phi$ | Alarm signal CSF13 | | | | | | | | | | | | | | |
| Δf | Alarm signal NC23 | | | | | | | | | | | | | | |
| t_{VC} | Alarm signal CSF23 | | | | | | | | | | | | | | |
| <p>The address code of the measuring relay module, required by the serial communication system.</p> <p>Submenu 1: Selection of the data transfer rate.</p> <p>Submenu 2: Bus traffic monitor. If the relay module is connected to a data communication system and the communication is operating, the counter reading of the bus traffic monitor will be 0. Otherwise the numbers 0...255 are continuously rolling in the counter.</p> <p>Submenu 3: Password required for remote setting. The password given in the setting mode of a submenu must always be entered via the serial communication before the settings can be altered remotely.</p> <p>Submenu 4: Status information for the main/second setting bank. The selection menu status for settings is used for activating either the main setting (0) or the second setting (1) values.</p> | | | | | | | | | | | | | | | |

When the display of the relay is dark, the register can be re-entered by pressing the STEP push-button.

The registers 1...9 are cleared and reset by pressing the RESET and PROGRAM push-buttons simultaneously. The registers are also cleared if the auxiliary power supply is interrupted. The

address code of the relay module, the data transfer rate of the serial communication and the password of the module are not affected by voltage failures. Instructions for setting the address and the data transfer rate are given in the document "General characteristics of D-type relay modules".

Menu chart

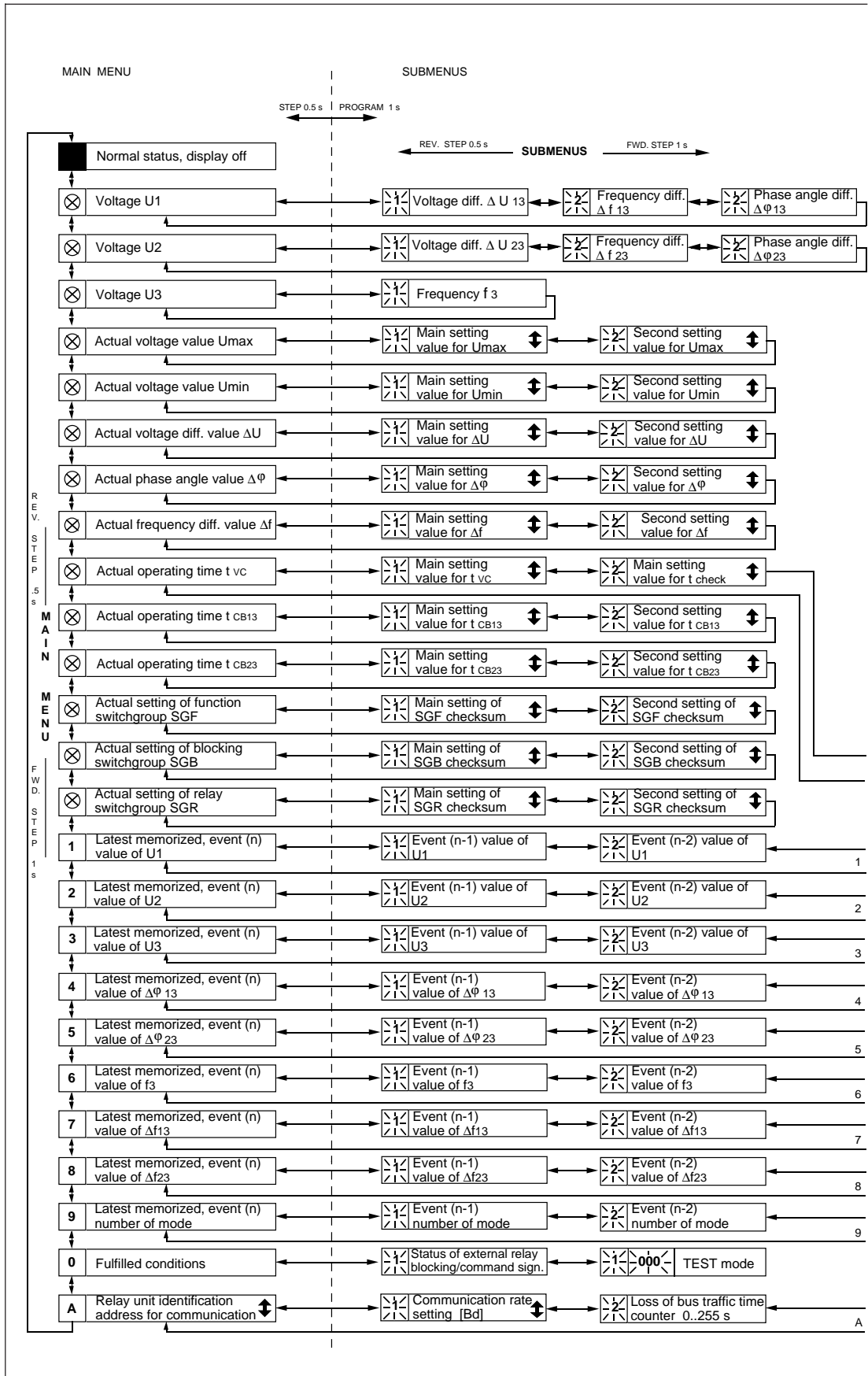

Fig. 12. Main menu and submenus of the synchro-check module SPCU 3D45

The procedure for entering a submenu or a setting mode and configuring the module is described in detail in "General characteristics of

D-type SPC relay modules". Below a simplified instruction.

| Desired step or operation | Push-button | Action |
|-------------------------------------|----------------|----------------------|
| Forward step in main or submenu | STEP | Press > 0.5 s |
| Rapid scan forward in main menu | STEP | Keep depressed |
| Reverse step in main or submenu | STEP | Press < 0.5 s |
| Entering a submenu from a main menu | PROGRAM | Press 1 s |
| Entering or leaving setting mode | PROGRAM | Press for 5 s |
| Increasing a value in setting mode | STEP | |
| Moving the cursor in setting mode | PROGRAM | Press about 1 s |
| Storing a value in setting mode | STEP & PROGRAM | Press simultaneously |
| Resetting of memorized values | STEP & PROGRAM | |

Note! All parameters which can be set in the setting mode are indicated with the symbol \updownarrow .

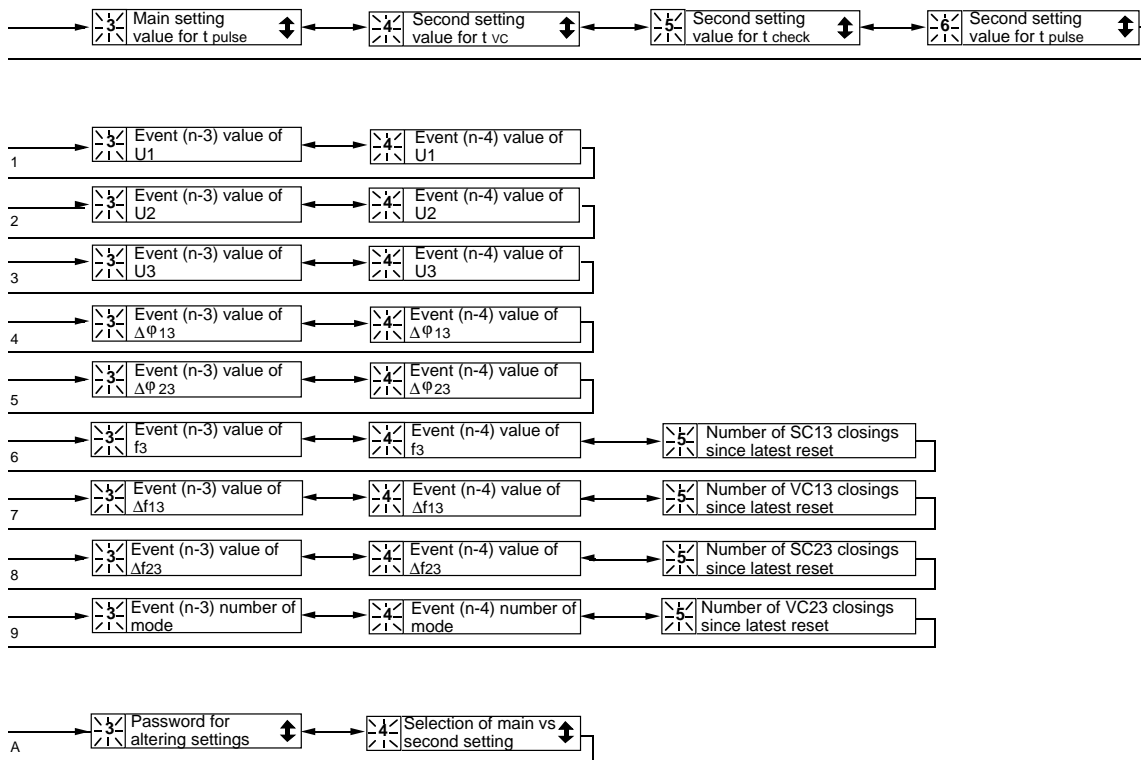

Technical data

Synchro-check function

| | |
|---|---|
| Upper threshold voltage U_{\max} | |
| Setting range | $0.5...1.0 \times U_n$ |
| Resolution | $0.01 \times U_n$ |
| Voltage difference ΔU | |
| Setting range | $0.02...0.4 \times U_n$ |
| Resolution | $0.01 \times U_n$ |
| Frequency difference Δf | |
| Setting range | $0.02...0.5 \text{ Hz}$ |
| Resolution | 0.01 Hz |
| Phase angle difference $\Delta\phi$ | |
| Setting range | $5...50^\circ$ |
| Resolution | 1° |
| Measuring time when the energizing voltages U_1 , U_2 and U_3 increase from 0 V to $1 \times U_n$, fixed value | $160 \text{ ms} \pm 20 \text{ ms}$ |
| Rated frequency f_n | $50/60 \text{ Hz}$ |
| Frequency range | $45...65 \text{ Hz}$ |
| Reset time | $<120 \text{ ms}$ |
| Operation accuracy | |
| - Voltage difference ΔU | $\pm 3\%$ of set value or $\pm 0.02 \times U_n$ |
| - Frequency difference Δf | $\pm 0.02 \text{ Hz}$ |
| - Phase angle difference $\Delta\phi$ | $\pm 2^\circ$ |
| Measuring of frequency and phase angle difference | measurable when the voltage $>0.15 \times U_n$ |

Voltage-check function

| | |
|--|--|
| Upper threshold voltage U_{\max} , the same as for synchro-check function | |
| Setting range | $0.5...1.0 \times U_n$ |
| Resolution | $0.01 \times U_n$ |
| Lower threshold voltage U_{\min} | |
| Setting range | $0.1...0.8 \times U_n$ |
| Resolution | $0.01 \times U_n$ |
| Selectable energizing directions | |
| Stage 1: | both "cold" or $U_1 \rightarrow U_3$ or $U_1 \leftarrow U_3$ $U_1 \rightarrow U_3$ $U_1 \leftarrow U_3$ $U_1 \rightarrow U_3$ or $U_1 \leftarrow U_3$ |
| Stage 2: | both "cold" or $U_2 \rightarrow U_3$ or $U_2 \leftarrow U_3$ $U_2 \rightarrow U_3$ $U_2 \leftarrow U_3$ $U_2 \rightarrow U_3$ or $U_2 \leftarrow U_3$ |
| Operate time ("dead-time") t_{VC} | |
| Setting range | $0.1...20 \text{ s}$ |
| Operate time accuracy | $\pm 2\%$ of set value or $\pm 25 \text{ ms}$ |
| Reset time | $<120 \text{ ms}$ |
| Operation accuracy | $\pm 3\%$ of set value or $\pm 0.02 \times U_n$ |

Command mode operation

| | |
|--|-------------------------|
| Length of CB closing signal, t_{pulse} | |
| Setting range | $0.2...20 \text{ s}$ |
| Check time for closing operation, t_{check} | |
| Setting range | $0.05...300 \text{ s}$ |
| Operate time of CB for stage 1, t_{CB13} | |
| Setting range | $0.05...0.25 \text{ s}$ |
| Operate time of CB for stage 2, t_{CB23} | |
| Setting range | $0.05...0.25 \text{ s}$ |

Serial communication parameters

Event codes

When the synchro-check relay module SPCU 3D45 is connected to a data communicator over the SPA bus, the module will generate event markings that can be printed out, for instance, on a printer or transmitted to higher system levels via the serial bus. The events are printed out in the format: time, text and event code. The event text is written by the user.

An event to be communicated, is marked with the multiplier 1. If the event is to be excluded the multiplier is 0. The event mask is formed by the sum of the weighting coefficients of all the events to be communicated.

The synchro-check and voltage-check functions of stage 1 and 2 are monitored by codes E1...E6 and E7...E12, respectively, and the events representing these can be included in or excluded from the event reporting by writing an event masks V155 and V156 for the module. The event masks may have a value within the range 0...63. The default value of the synchro-check relay module is 36 for V155 and V156, which means that all closing operations of the separate stages are included in the event reporting.

The status of the input signals is monitored by codes E13...E20 and the events representing these can be included in or excluded from the event reporting by writing the required value to an event mask V158. The event mask may have a value within the range 0...255 and the default value of the relay module is 0. This means that

no operations of the input signals are included in the event reporting.

The status of the output signals is monitored by codes E21...E26 and the events representing these can be included in or excluded from the event reporting by writing an event mask V157 to the relay module. The event mask may have a value within the range 0...63 and the default value of the relay module is 63. Thus, all operations of the output signals and status changes are included in the event reporting.

The event codes E50...E54 and the events represented by these cannot be excluded from the event reporting. The event codes E52...E54 are generated by the data communicator used, for example, SACO 100M, SRIO 1000M, etc.

The synchro-check relay module has its own event register where all events are recorded in operating order. The memory is capable of storing up to eight events. When the ninth event occurs the code E51 is recorded in the event register, thus, reporting an overflow in the event register. The event register can be cleared over the serial communication bus by writing the value 0 to the serial communication parameter C (resetting of module state data).

Detailed information about the serial communication over the SPA bus is given in the document "SPA bus communication protocol", Document No. 34 SPACOM 2 EN1.

| Event mask | Code | Setting range | Default value |
|------------|-----------|---------------|---------------|
| V155 | E1...E6 | 0...63 | 36 |
| V156 | E7...E12 | 0...63 | 36 |
| V157 | E21...E26 | 0...63 | 63 |
| V158 | E13...E20 | 0...255 | 0 |

| Code | Event | Weighting coefficient | Default setting |
|----------------------------------|------------------------------------|-----------------------|-----------------|
| E1 | Starting of SC13 | 1 | 0 |
| E2 | Starting of SC13 reset | 2 | 0 |
| E3 | Closing permission/command of SC13 | 4 | 1 |
| E4 | Starting of VC13 | 8 | 0 |
| E5 | Starting of VC13 reset | 16 | 0 |
| E6 | Closing permission/command of VC13 | 32 | 1 |
| Default value of event mask V155 | | | 36 |

| Code | Event | Weighting coefficient | Default setting |
|----------------------------------|------------------------------------|-----------------------|-----------------|
| E7 | Starting of SC23 | 1 | 0 |
| E8 | Starting of SC23 reset | 2 | 0 |
| E9 | Closing permission/command of SC23 | 4 | 1 |
| E10 | Starting of VC23 | 8 | 0 |
| E11 | Starting of VC23 reset | 16 | 0 |
| E12 | Closing permission/command of VC23 | 32 | 1 |
| Default value of event mask V156 | | | 36 |

| | | | |
|----------------------------------|-----------------------------|-----|---|
| E13 | Input signal BS13 activated | 1 | 0 |
| E14 | Input signal BS13 reset | 2 | 0 |
| E15 | Input signal CS13 activated | 4 | 0 |
| E16 | Input signal CS13 reset | 8 | 0 |
| E17 | Input signal BS23 activated | 16 | 0 |
| E18 | Input signal BS23 reset | 32 | 0 |
| E19 | Input signal CS23 activated | 64 | 0 |
| E20 | Input signal CS23 reset | 128 | 0 |
| Default value of event mask V158 | | | 0 |

| | | | |
|----------------------------------|-------------------------------|----|----|
| E21 | Output signal CB13 activated | 1 | 1 |
| E22 | Output signal CB13 reset | 2 | 1 |
| E23 | Output signal CB23 activated | 4 | 1 |
| E24 | Output signal CB23 reset | 8 | 1 |
| E25 | Output signal ALARM activated | 16 | 1 |
| E26 | Output signal ALARM reset | 32 | 1 |
| Default value of event mask V157 | | | 63 |

| | | | |
|-----|---|---|---|
| E50 | Restart of microprocessor | * | - |
| E51 | Overflow of event register | * | - |
| E52 | Temporary interruption in data communication | * | - |
| E53 | No response from the relay module over the data communication bus | * | - |
| E54 | The relay module responds again over the data communication bus | * | - |

Explanations:

- 0 not included in event reporting
- 1 included in event reporting
- * no code number, always included in event reporting
- cannot be set

- SC13 synchro-check function of stage 1
- SC23 synchro-check function of stage 2
- VC13 voltage-check function of stage 1
- VC23 voltage-check function of stage 2

Data to be transferred over the serial bus

In addition to the event code data transfer, the input data (I data), output data (O data), setting values (S), memorized data (V data) and some other data can be read from the relay

module over the serial communication bus. Further, part of the data can be changed over the SPA bus by separate commands. All data information is available in channel 0.

| Data | Code | Data direction | Value |
|---|------|----------------|--|
| <i>Input data</i> | | | |
| Measured voltage value U1 | I1 | R | 0.00 ... 1.3 x U _n |
| Measured voltage value U2 | I2 | R | 0.00 ... 1.3 x U _n |
| Measured voltage value U3 | I3 | R | 0.00 ... 1.3 x U _n |
| Measured voltage difference value U1-U3 | I4 | R | 0.00 ... 1.3 x U _n |
| Measured voltage difference value U2-U3 | I5 | R | 0.00 ... 1.3 x U _n |
| Measured frequency value of U3 | I6 | R | 45.0 ... 65.0 Hz |
| Measured frequency difference value U1-U3 | I7 | R | ±0.00 ... ±20.0 Hz 999 = not measurable |
| Measured frequency difference value U2-U3 | I8 | R | ±0.00 ... ±20.0 Hz 999 = not measurable |
| Measured phase angle difference value U1-U3 | I9 | R | 0 ... ±180° 999 = not measurable |
| Measured phase angle difference value U2-U3 | I10 | R | 0 ... ±180° 999 = not measurable |
| External command signal CS13 | I11 | R | 0 = not active 1 = active |
| External command signal CS23 | I12 | R | 0 = not active 1 = active |
| External blocking signal BS13 | I13 | R | 0 = not active 1 = active |
| External blocking signal BS23 | I14 | R | 0 = not active 1 = active |
| <i>Output data</i> | | | |
| Starting of SC13 (U _{max} conditions are fulfilled) | O1 | R | 0 = not started 1 = started |
| SC13 closing | O2 | R | 0 = not closed 1 = closed |
| Starting of VC13 | O3 | R | 0 = not started 1 = started |
| VC13 closing | O4 | R | 0 = not closed 1 = closed |
| Starting of SC23 (U _{max} conditions are fulfilled) | O5 | R | 0 = not started 1 = started |
| SC23 closing | O6 | R | 0 = not closed 1 = closed |
| Starting of VC23 | O7 | R | 0 = not started 1 = started |
| VC23 closing | O8 | R | 0 = not closed 1 = closed |
| Closing signal CB13 | O9 | R,W,(P) | 0 = not active 1 = active |
| Closing signal CB23 | O10 | R,W,(P) | 0 = not active 1 = active |
| Output signal ALARM | O11 | R,W,(P) | 0 = not active 1 = active |
| Operation of output relays, ENA signal | O41 | R,W,(P) | 0 = not operated 1 = operated |
| Memorized output signal ALARM | O21 | R | 0 = no alarm 1 = alarm |

| Data | Code | Data direction | Value |
|--|------|----------------|-----------------------|
| <i>Setting values</i> | | | |
| General setting values for reading: | | | |
| Upper threshold voltage U_{\max} | S1 | R | 0.50 ... 1.00 x U_n |
| Lower threshold voltage U_{\min} | S2 | R | 0.10 ... 0.80 x U_n |
| Voltage difference value ΔU | S3 | R | 0.02 ... 0.40 x U_n |
| Phase angle difference value $\Delta\phi$ | S4 | R | 5 ... 50° |
| Frequency difference value Δf | S5 | R | 0.02 ... 0.50 Hz |
| Operate time (dead time) for t_{VC} | S6 | R | 0.10 ... 20 s |
| Check time in command mode operation, t_{check} | S7 | R | 0.05 ... 300 s |
| Closing signal length t_{pulse} (only in command mode operation) | S8 | R | 0.2 ... 20 s |
| Operate time of circuit breaker, t_{CB13} (stage 1) | S9 | R | 0.05 ... 0.25 s |
| Operate time of circuit breaker, t_{CB23} (stage 2) | S10 | R | 0.05 ... 0.25 s |
| Checksum of switchgroup SGF | S11 | R | 0 ... 255 |
| Checksum of switchgroup SGB | S12 | R | 0 ... 255 |
| Checksum of switchgroup SGR | S13 | R | 0 ... 255 |
| <i>Main settings</i> | | | |
| Upper threshold voltage U_{\max} | S21 | R,W,(P) | 0.50 ... 1.00 x U_n |
| Lower threshold voltage U_{\min} | S22 | R,W,(P) | 0.10 ... 0.80 x U_n |
| Voltage difference ΔU | S23 | R,W,(P) | 0.02 ... 0.40 x U_n |
| Phase angle difference $\Delta\phi$ | S24 | R,W,(P) | 5 ... 50° |
| Frequency difference Δf | S25 | R,W,(P) | 0.02 ... 0.50 Hz |
| Operate time (dead time) t_{VC} | S26 | R,W,(P) | 0.10 ... 20 s |
| Check time in command mode operation, t_{check} | S27 | R,W,(P) | 0.05 ... 300 s |
| Closing signal length t_{pulse} (only in command mode operation) | S28 | R,W,(P) | 0.2 ... 20 s |
| Operate time of circuit breaker t_{CB13} (stage 1) | S29 | R,W,(P) | 0.05 ... 0.25 s |
| Operate time of circuit breaker t_{CB23} (stage 2) | S30 | R,W,(P) | 0.05 ... 0.25 s |
| Checksum of switchgroup SGF | S31 | R,W,(P) | 0 ... 255 |
| Checksum of switchgroup SGB | S32 | R,W,(P) | 0 ... 255 |
| Checksum of switchgroup SGR | S33 | R,W,(P) | 0 ... 255 |
| <i>Second settings</i> | | | |
| Upper threshold voltage U_{\max} | S41 | R,W,(P) | 0.50 ... 1.00 x U_n |
| Lower threshold voltage U_{\min} | S42 | R,W,(P) | 0.10 ... 0.80 x U_n |
| Voltage difference ΔU | S43 | R,W,(P) | 0.02 ... 0.40 x U_n |
| Phase angle difference $\Delta\phi$ | S44 | R,W,(P) | 5 ... 50° |
| Frequency difference Δf | S45 | R,W,(P) | 0.02 ... 0.50 Hz |
| Operate time (dead time) t_{VC} | S46 | R,W,(P) | 0.10 ... 20 s |
| Check time in command mode operation, t_{check} | S47 | R,W,(P) | 0.05 ... 300 s |
| Closing signal length t_{pulse} (only in command mode operation) | S48 | R,W,(P) | 0.2 ... 20 s |
| Operate time of circuit breaker t_{CB13} (stage 1) | S49 | R,W,(P) | 0.05 ... 0.25 s |
| Operate time of circuit breaker t_{CB23} (stage 2) | S50 | R,W,(P) | 0.05 ... 0.25 s |
| Checksum of switchgroup SGF | S51 | R,W,(P) | 0 ... 255 |
| Checksum of switchgroup SGB | S52 | R,W,(P) | 0 ... 255 |
| Checksum of switchgroup SGR | S53 | R,W,(P) | 0 ... 255 |

| Data | Code | Data direction | Value |
|---|-------------------------------|----------------|---|
| <i>Recorded values</i> | | | |
| Voltage U1 | V11, V21, V31, V41, V51 | R | 0.00 ... 1.3 x U _n 999 = closing by stage 2 |
| Voltage U2 | V12, V22, V32, V42, V52 | R | 0.00 ... 1.3 x U _n 999 = closing by stage 1 |
| Voltage U3 | V13, V23, V33, V43, V53 | R | 0.00 ... 1.3 x U _n |
| Phase angle difference $\Delta\varphi_{13}$ | V14, V24, V34, V44, V54 | R | 0 ... 180° 999 = closing by stage 2 or closing by voltage- check function in stage 1 |
| Phase angle difference $\Delta\varphi_{23}$ | V15, V25, V35, V45, V55 | R | 0 ... 180° 999 = closing by stage 1 or closing by voltage- check function in stage 2 |
| Frequency of voltage U3 | V16, V26 V36, V46, V56 | R | 0, 45.00 ... 65.00 Hz 999 = not measurable |
| Frequency difference Δf_{13} | V17, V27, V37, V47, V57 | R | 0.00 ... 20.0 Hz 999 = closing by stage 2 or closing by voltage- check function in stage 1 |
| Frequency difference Δf_{23} | V18, V28, V38, V48, V58 | R | 0.00 ... 20.0 Hz 999 = closing by stage 1 or closing by voltage- check function in stage 2 |
| Stage and function for closing | V19, V29, V39, V49, V56 | R | 1 = SC13, 2 = VC13 4 = SC23, 8 = VC23 |
| Number of startings of SC13 | V1 | R | 0 ... 255 |
| Number of closings of SC13 | V2 | R | 0 ... 255 |
| Number of startings of VC13 | V3 | R | 0 ... 255 |
| Number of closings of VC13 | V4 | R | 0 ... 255 |
| Number of startings of SC23 | V5 | R | 0 ... 255 |
| Number of closings of SC23 | V6 | R | 0 ... 255 |
| Number of startings of VC23 | V7 | R | 0 ... 255 |
| Number of closings of VC23 | V8 | R | 0 ... 255 |
| Operation indicator | V9 | R | 0 ... 6 |

| Data | Code | Data direction | Value |
|--|------|----------------|--|
| <i>Control parameters</i> | | | |
| Resetting of recorded data | V102 | W | 1 = registers are reset |
| Remote control of main and second settings | V150 | R,W | 0 = main settings activated 1 = second settings activated |
| Event mask for events of stage 1 | V155 | R,W | 0 ... 255, see "Event codes" |
| Event mask for events of stage 2 | V156 | R,W | 0 ... 255, see "Event codes" |
| Event mask for output signals | V157 | R,W | 0 ... 255, see "Event codes" |
| Event mask for input signals | V158 | R,W | 0 ... 255, see "Event codes" |
| Opening of password for remote setting | V160 | W | 1 ... 999 |
| Changing or closing of remote setting password | V161 | W,(P) | 0 ... 999 |
| Activation of self-supervision function | V165 | W | 1 = self-supervision output activated and IRF LED indicator switched on |
| LED indicator test | V166 | W,(P) | 0 ... 15 |
| Final factory test | V167 | W,(P) | 1 = display segment test 2 = initialization of EEPROM and power reset |
| Internal fault code | V169 | R | 0 ... 255 |
| Data communication address of the module | V200 | R,W | |
| Data transfer rate | V201 | R,W | 4800 or 9600 Bd (R) 4.8 or 9.6 kBd (W) |
| Program version | V205 | R | 076_ |
| Reading of event register | L | R | Time, channel number and event code |
| Re-reading of event register | B | R | Time, channel number and event code |
| Type designation of the relay module | F | R | SPCU 3D45 |
| Reading of module status data | C | R | 0 = normal status 1 = module been subject to automatic reset 2 = overflow of event register 3 = events 1 and 2 together |
| Resetting of module status data | C | W | 0 = resetting |
| Time reading or setting | T | R,W | 00.000 ... 59.999 s |

Explanations:

R = data to be read from the relay module
W = data to be written to the relay module
(P) = writing allowed through a password

SC13 synchro-check function of stage 1
SC23 synchro-check function of stage 2
VC13 voltage-check function of stage 1
VC23 voltage-check function of stage 2

The event register can be read by the L command only once. Should a fault occur, for example, in the data communication, the B command can be used to re-read the contents of the register. When required, the B command can be repeated. Generally, the control data communicator reads the event data and forwards the information to an output device. Under normal conditions the event register of the relay module is empty. The control data communicator also resets abnormal status data, so this data is normally zero.

The setting values S1...S13 are values used by the checking functions. All main settings S21...S33 and second settings S41...S53 can be read and written. The condition for writing is that the remote set password has been opened.

When a setting value is changed, either by means of the push-buttons on the front panel or over the serial communication bus, the relay module checks whether the given parameter value is legal, that is, within the permitted range. A value outside the permitted setting range will not be memorized, but the previous setting value will be retained.

Activation of the self-supervision function (V165) prevents the synchro-check relay from operating during the time when the self-supervision output is active and the IRF LED is lit.

Fault codes

Once the self-supervision system has detected a permanent relay fault, the IRF LED on the front panel of the module is lit, and at the same time the normally operated signal relay of the self-supervision system drops off.

a red digit one (1) and a green code number that indicates the fault type. The fault code should be recorded and stated when service is ordered.

In most fault situations an auto-diagnostic fault code is shown on the relay display. The fault code cannot be reset. The fault code consists of

The fault codes of the synchro-check relay module SPCU 3D45 are explained in the following table:

| Fault code | Explanation |
|------------|---|
| 1 | Power reset |
| 4 | Faulty output relay path or missing output relay card |
| 30 | Faulty program memory (ROM) |
| 50 | Faulty working memory (RAM) |
| 51 | Faulty parameter memory (EEPROM) for block 1 |
| 52 | Faulty parameter memory (EEPROM) for block 2 |
| 53 | Faulty parameter memory (EEPROM) for block 1 and 2 |
| 54 | Faulty parameter memory (EEPROM) for block 1 and 2 with different checksums |
| 56 | Faulty parameter memory (EEPROM) key |
| 195 | Too low a value in reference channel with multiplier 1 |
| 131 | Too low a value in reference channel with multiplier 5 |
| 67 | Too low a value in reference channel with multiplier 25 |
| 203 | Too high a value in reference channel with multiplier 1 |
| 139 | Too high a value in reference channel with multiplier 5 |
| 75 | Too high a value in reference channel with multiplier 25 |
| 253 | No interruptions from the A/D-converter |

Calculation of the checksum

Example of calculating the checksum of selector switchgroup SGF.

| Switch No | Position | | Weighting coefficient | | Value |
|-----------------------------|----------|---|-----------------------|---|-------|
| SGF/1 | 1 | x | 1 | = | 1 |
| SGF/2 | 0 | x | 2 | = | 0 |
| SGF/3 | 1 | x | 4 | = | 4 |
| SGF/4 | 0 | x | 8 | = | 0 |
| SGF/5 | 0 | x | 16 | = | 0 |
| SGF/6 | 0 | x | 32 | = | 0 |
| SGF/7 | 1 | x | 64 | = | 64 |
| SGF/8 | 0 | x | 128 | = | 0 |
| Checksum of switchgroup SGF | | | Σ | = | 69 |

When the checksum calculated according to the example equals the checksum indicated on the display of the relay module, the switches in the concerned switchgroup are correctly set. An ex-

ample of calculating the checksum and detailed information of keypad operations is contained in the general description of the D-type SPC relay modules.

Test function

Register 0 provides access to a test function, which allows the output signals of the relay module to be activated one by one. If the auxiliary relay module of the protection assembly is in place, the auxiliary relays will operate one by one during the testing.

Note!

The closing conditions of the circuit breaker are not checked when the output signals of the test function are activated (forced control).

When pressing the PROGRAM push-button for about five seconds, the green digits to the right of the display start flashing indicating that the relay module is in the test position. The self-supervision output is initially tested in the test position. The indicators of the settings indicate by flashing which output signal can be activated. The required output function is selected by pressing the STEP push-button for 1 second when no setting indicator is flashing. The IRF output function is selected by pressing the PROGRAM push-button for about one second.

The indicators of the setting quantities refer to the following output signals:

| | |
|--------------------------|----------------------|
| No indication | Self-supervision IRF |
| Setting U_{max} | Closing signal CB13 |
| Setting U_{min} | Closing signal CB23 |
| Setting ΔU | Alarm signal NC13 |
| Setting $\Delta \varphi$ | Alarm signal CSF13 |
| Setting Δf | Alarm signal NC23 |
| Setting t_{VC} | Alarm signal CSF23 |

The selected output signal is activated by simultaneous pressing of the push-buttons STEP and PROGRAM. The signal remains activated as long as the two push-buttons are pressed. The effect on the output relays depends on the configuration of the output relay matrix switches.

The self-supervision output is activated by pressing the STEP push button for 1 second when no setting indicator is flashing. The IRF output is activated in about 1 second after pressing of the STEP push button.

The signals are selected in the order illustrated in figure 13.

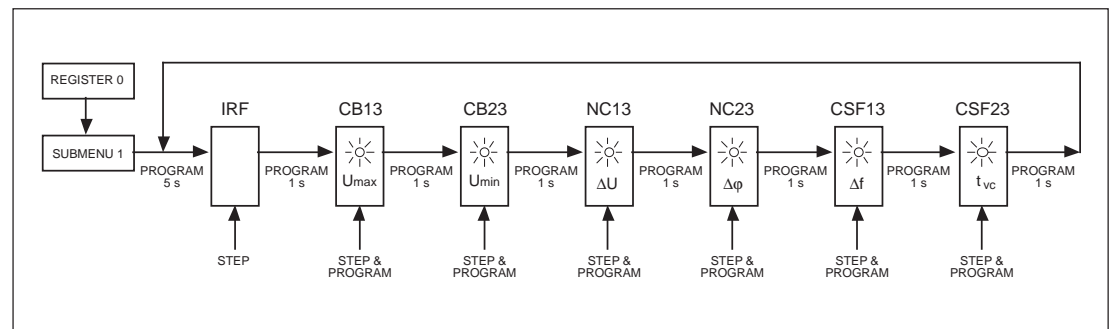
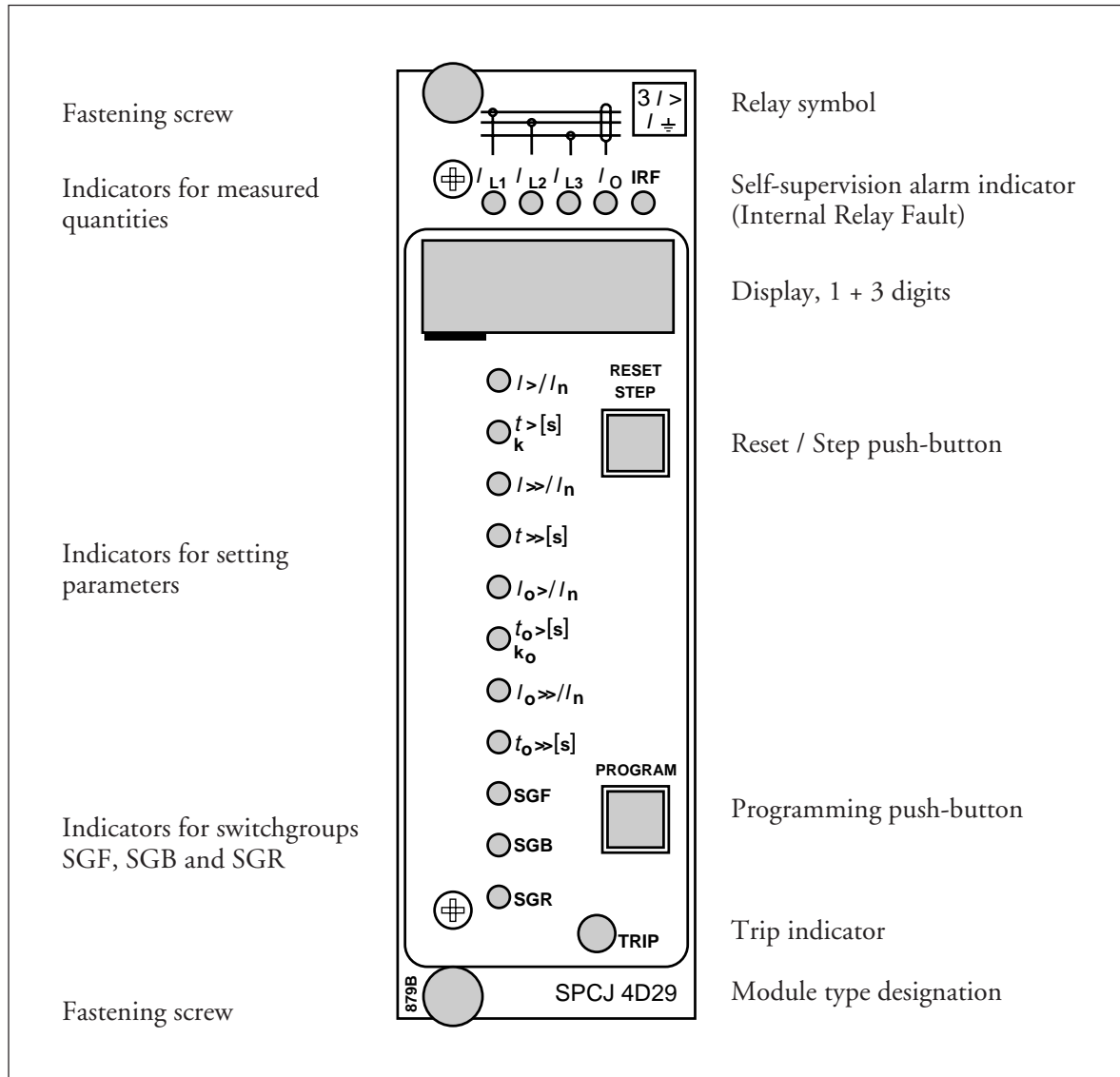

Fig. 13. Sequence order for the selection of output signals in the Test mode.

General characteristics of D-type relay modules

User's manual and Technical description



General characteristics of D type relay modules

Data subject to change without notice

Contents

| | |
|--|----|
| Front panel lay-out | 1 |
| Control push buttons | 3 |
| Display | 3 |
| Display main menu | 3 |
| Display submenus | 3 |
| Selector switchgroups SGF, SGB, SGR | 4 |
| Settings | 4 |
| Setting mode | 4 |
| Example 1: Setting of relay operation values | 7 |
| Example 2: Setting of relay switchgroups | 9 |
| Recorded information | 11 |
| Trip test function | 12 |
| Example 3: Forced activation of outputs | 13 |
| Operation indicators | 15 |
| Fault codes | 15 |

| | | |
|-----------------------------|---|--|
| Control push-buttons | The front panel of the relay module contains two push buttons. The RESET / STEP push button is used for resetting operation indicators and for stepping forward or backward in the display main menu or submenus. The PROGRAM push button is used for moving from a | certain position in the main menu to the corresponding submenu, for entering the setting mode of a certain parameter and together with the STEP push button for storing the set values. The different operations are described in the subsequent paragraphs in this manual. |
| Display | The measured and set values and the recorded data are shown on the display of the protection relay module. The display consists of four digits. The three green digits to the right show the measured, set or recorded value and the leftmost red digit shows the code number of the register. The measured or set value displayed is indicated by the adjacent yellow LED indicator on the front panel. When a recorded fault value is being displayed the red digit shows the number of the corresponding register. When the display functions as an operation indicator the red digit alone is shown. | When the auxiliary voltage of a protection relay module is switched on the module initially tests the display by stepping through all the segments of the display for about 15 seconds. At first the corresponding segments of all digits are lit one by one clockwise, including the decimal points. Then the center segment of each digit is lit one by one. The complete sequence is carried out twice. When the test is finished the display turns dark. The testing can be interrupted by pressing the STEP push button. The protection functions of the relay module are alerted throughout the testing. |
| Display main menu | <p>Any data required during normal operation are accessible in the main menu i.e. present measured values, present setting values and recorded parameter values.</p> <p>The data to be shown in the main menu are sequentially called up for display by means of the STEP push button. When the STEP push button is pressed for about one second, the display moves forward in the display sequence. When the push button is pressed for about 0.5 seconds, the display moves backward in the display sequence.</p> | <p>From a dark display only forward movement is possible. When the STEP push button is pushed constantly, the display continuously moves forward stopping for a while in the dark position.</p> <p>Unless the display is switched off by stepping to the dark point, it remains lit for about 5 minutes from the moment the STEP push button was last pushed. After the 5 minutes' time-out the display is switched off.</p> |
| Display submenus | <p>Less important values and values not very often set are displayed in the submenus. The number of submenus varies with different relay module types. The submenus are presented in the description of the concerned protection relay module.</p> <p>A submenu is entered from the main menu by pressing the PROGRAM push button for about one second. When the push button is released, the red digit of the display starts flashing, indicating that a submenu has been entered. Going from one submenu to another or back to the main menu follows the same principle as when moving from the main menu display to another;</p> | <p>the display moves forward when the STEP push button is pushed for one second and backward when it is pushed for 0.5 seconds. The main menu has been re-entered when the red display turns dark.</p> <p>When a submenu is entered from a main menu of a measured or set value indicated by a LED indicator, the indicator remains lit and the address window of the display starts flashing. A submenu position is indicated by a flashing red address number alone on the display without any lit set value LED indicator on the front panel.</p> |

Selector switch-groups SGF, SGB and SGR

Part of the settings and the selections of the operation characteristic of the relay modules in various applications are made with the selector switchgroups SG_. The switchgroups are software based and thus not physically to be found in the hardware of the relay module. The indicator of the switchgroup is lit when the checksum of the switchgroup is shown on the display. Starting from the displayed checksum and by entering the setting mode, the switches can be set one by one as if they were real physical switches. At the end of the setting procedure, a checksum for the whole switchgroup is shown. The checksum can be used for verifying that the switches have been properly set. Fig. 2 shows an example of a manual checksum calculation.

When the checksum calculated according to the example equals the checksum indicated on the display of the relay module, the switches in the concerned switchgroup are properly set.

| Switch No | Pos. | | Weight | Value |
|-----------------|------|---|----------|-------|
| 1 | 1 | x | 1 | = 1 |
| 2 | 0 | x | 2 | = 0 |
| 3 | 1 | x | 4 | = 4 |
| 4 | 1 | x | 8 | = 8 |
| 5 | 1 | x | 16 | = 16 |
| 6 | 0 | x | 32 | = 0 |
| 7 | 1 | x | 64 | = 64 |
| 8 | 0 | x | 128 | = 0 |
| Checksum | | | Σ | = 93 |

Fig. 2. Example of calculating the checksum of a selector switchgroup SG_.

The functions of the selector switches of the different protection relay modules are described in detail in the manuals of the different relay modules.

Settings

Most of the start values and operate times are set by means of the display and the push buttons on the front panel of the relay modules. Each setting has its related indicator which is lit when the concerned setting value is shown on the display.

In addition to the main stack of setting values most D type relay modules allow a second stack of settings. Switching between the main settings

and the second settings can be done in three different ways:

- 1) By command V150 over the serial communication bus
- 2) By an external control signal BS1, BS2 or RRES (BS3)
- 3) Via the push-buttons of the relay module, see submenu 4 of register A.

Setting mode

Generally, when a large number of settings is to be altered, e.g. during commissioning of relay systems, it is recommended that the relay settings are entered with the keyboard of a personal computer provided with the necessary software. When no computer nor software is available or when only a few setting values need to be altered the procedure described below is used.

The registers of the main menu and the submenus contain all parameters that can be set. The settings are made in the so called setting mode, which is accessible from the main menu or a submenu by pressing the PROGRAM push button, until the whole display starts flashing. This position indicates the value of the parameter before it has been altered. By pressing the PROGRAM push button the programming sequence moves forward one step. First the rightmost digit starts flashing while the rest of the display is steady. The flashing digit is set by means of the STEP push button. The flashing

cursor is moved on from digit to digit by pressing the PROGRAM push button and in each stop the setting is performed with the STEP push button. After the parameter values have been set, the decimal point is put in place. At the end the position with the whole display flashing is reached again and the data is ready to be stored.

A set value is recorded in the memory by pressing the push buttons STEP and PROGRAM simultaneously. Until the new value has been recorded a return from the setting mode will have no effect on the setting and the former value will still be valid. Furthermore *any attempt to make a setting outside the permitted limits for a particular parameter will cause the new value to be disqualified and the former value will be maintained.* Return from the setting mode to the main menu or a submenu is possible by pressing the PROGRAM push button until the green digits on the display stop flashing.

NOTE! During any local man-machine communication over the push buttons and the display on the front panel a five minute time-out function is active. Thus, if no push button has been pressed during the last five minutes, the relay returns to its normal state automatically. This means that the display turns dark, the relay escapes from a display mode, a programming routine or any routine going on, when the relay is left untouched. This is a convenient way out of any situation when the user does not know what to do.

Before a relay module is inserted into the relay case, one must assure that the module has been given the correct settings. If there however is

any doubt about the settings of the module to be inserted, the setting values should be read using a spare relay unit or with the relay trip circuits disconnected. If this cannot be done the relay can be set into a non-tripping mode by pressing the PROGRAM push button and powering up the relay module simultaneously. The display will show three dashes "---" to indicate the non-tripping mode. The serial communication is operative and all main and submenus are accessible. In the non-tripping mode unnecessary trippings are avoided and the settings can be checked. *The normal protection relay mode is entered automatically after a timeout of five minutes or ten seconds after the dark display position of the main menu has been entered.*

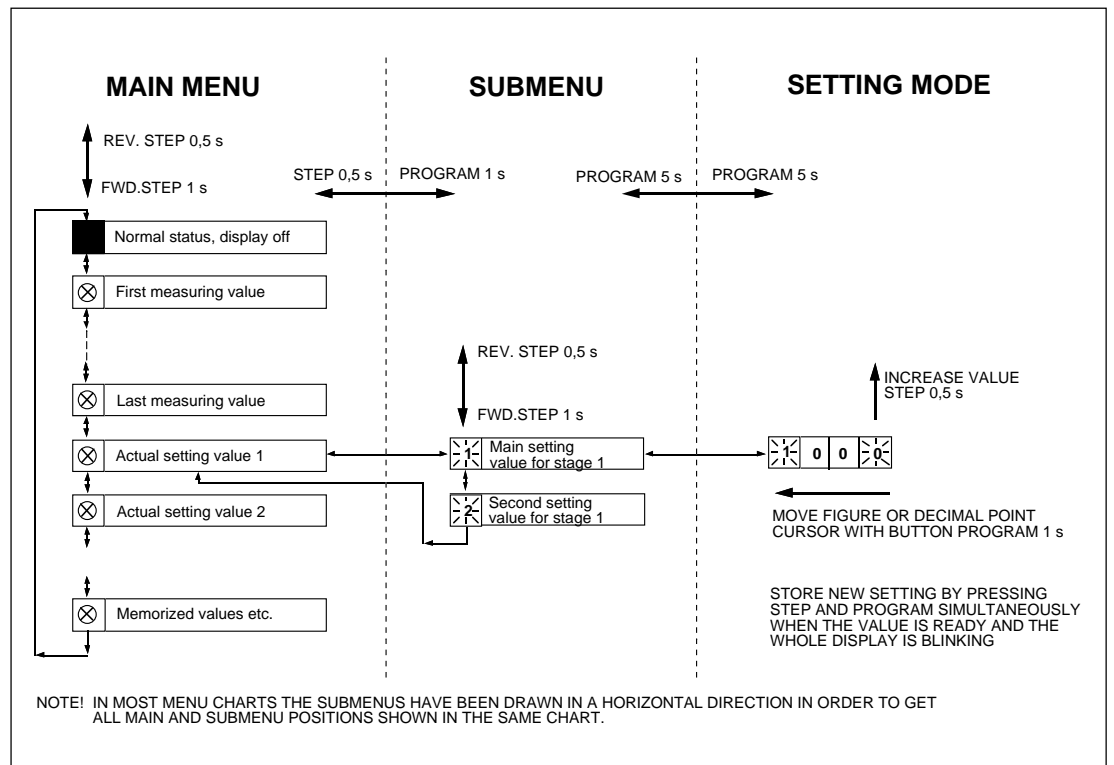

Fig.3. Basic principles of entering the main menus and submenus of a relay module.

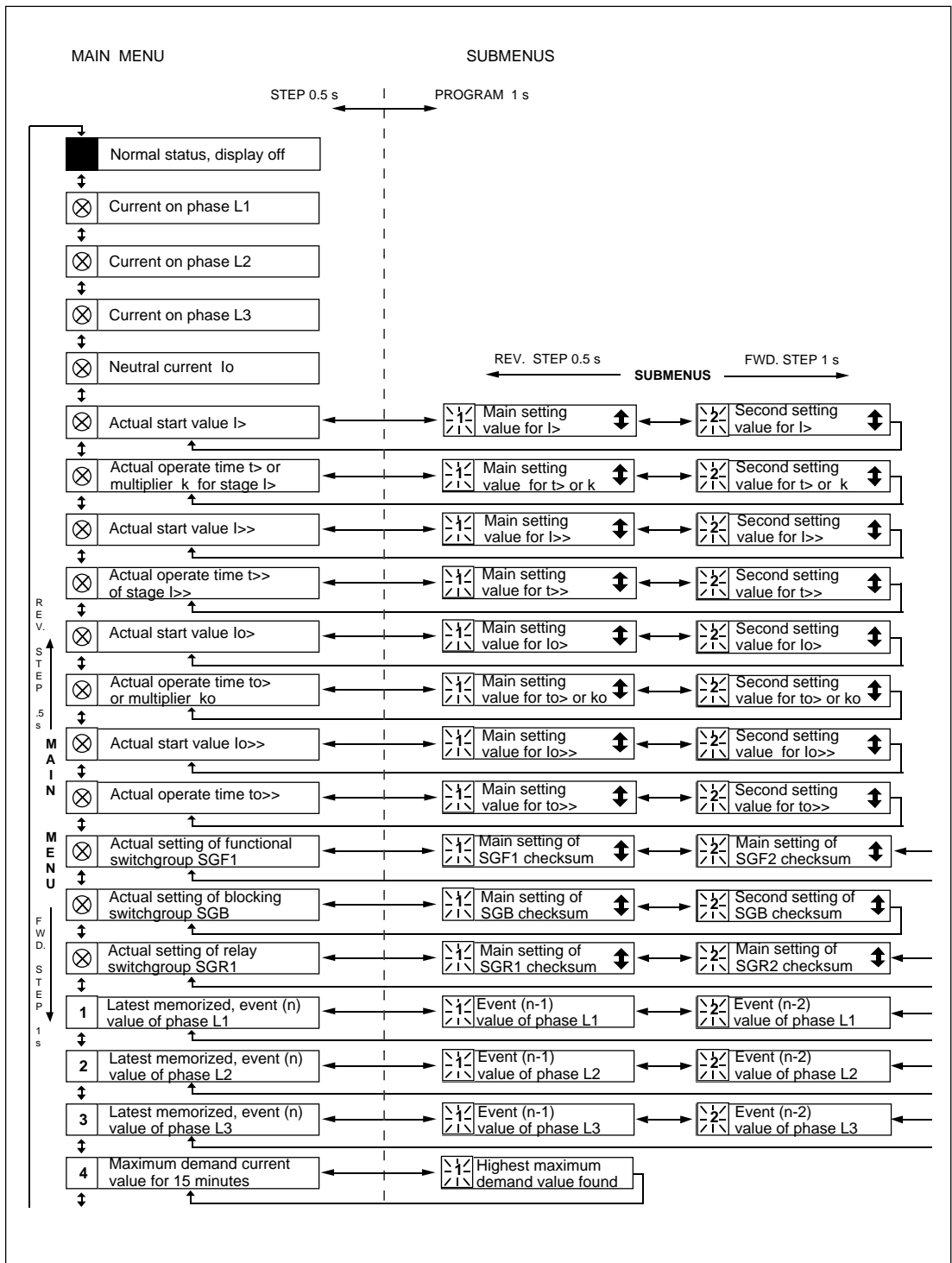

Fig. 4. Example of part of the main and submenus for the settings of the overcurrent and earth-fault relay module SPCJ 4D29. The settings currently in use are in the main menu and they are displayed by pressing the STEP push button. The main menu also includes the measured current values, the registers 1...9, 0 and A. The main and second setting values are located in the submenus and are called up on the display with the PROGRAM push button.

Example 1

Operation in the setting mode. Manual setting of the main setting of the start current value $I>$ of an overcurrent relay module. The initial value

for the main setting is $0.80 \times I_n$ and for the second setting $1.00 \times I_n$. The desired main start value is $1.05 \times I_n$.

a) Press push button STEP repeatedly until the LED close to the $I>$ symbol is lit and the current start value appears on the display.

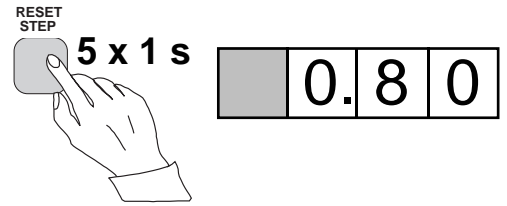

b) Enter the submenu to get the main setting value by pressing the PROGRAM push button more than one second and then releasing it. The red display digit now shows a flashing number 1, indicating the first submenu position and the green digits show the set value.

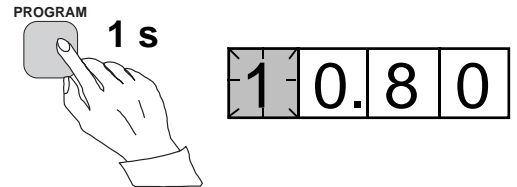

c) Enter the setting mode by pressing the PROGRAM push button for five seconds until the display starts flashing.

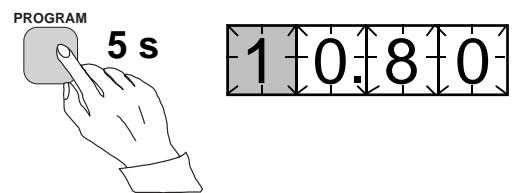

d) Press the PROGRAM push button once again for one second to get the rightmost digit flashing.

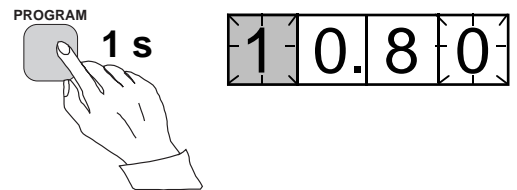

e) Now the flashing digit can be altered. Use the STEP push button to set the digit to the desired value.

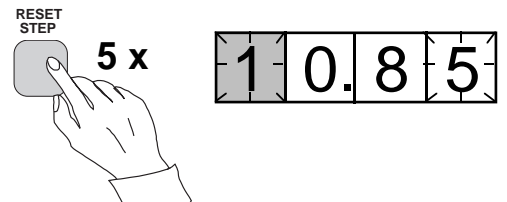

f) Press the PROGRAM push button to make the middle one of the green digits flash.

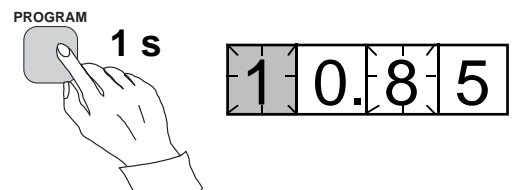

g) Set the middle digit with of the STEP push button.

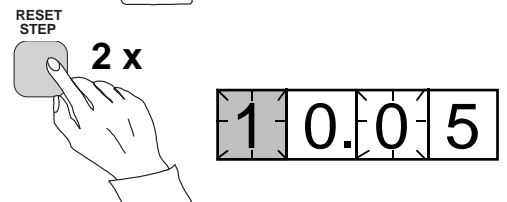

h) Press the PROGRAM push button to make the leftmost green digit flash.

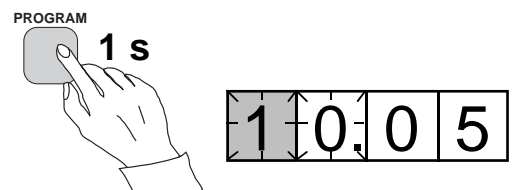

i) Set the digit with the STEP push button.

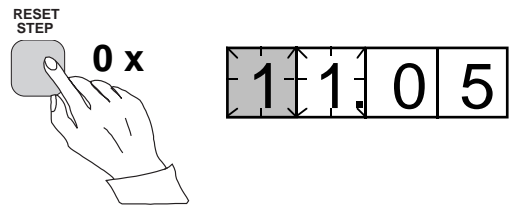

j) Press the PROGRAM push button to make the decimal point flash.

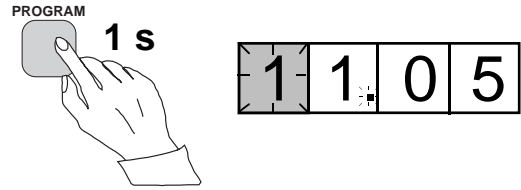

k) If needed, move the decimal point with the STEP push button.

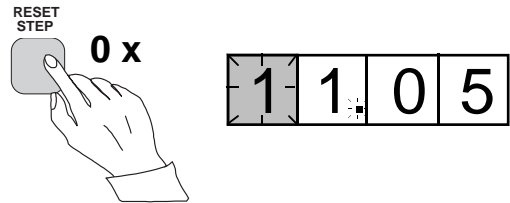

l) Press the PROGRAM push button to make the whole display flash. In this position, corresponding to position c) above, one can see the new value before it is recorded. If the value needs changing, use the PROGRAM push button to alter the value.

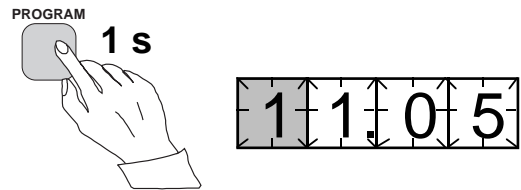

m) When the new value has been corrected, record it in the memory of the relay module by pressing the PROGRAM and STEP push buttons simultaneously. At the moment the information enters the memory, the green dashes flash once in the display, i.e. 1 - - -.

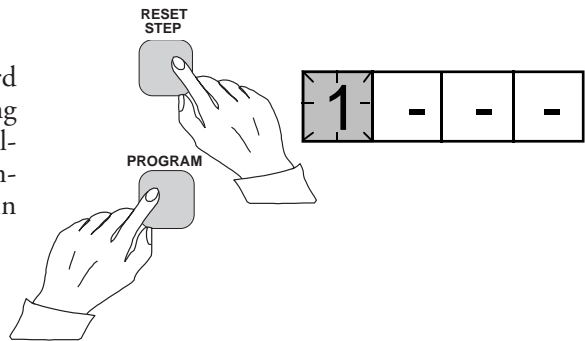

n) Recording of the new value automatically initiates a return from the setting mode to the normal submenu. Without recording one can leave the setting mode any time by pressing the PROGRAM push button for about five seconds, until the green display digits stop flashing.

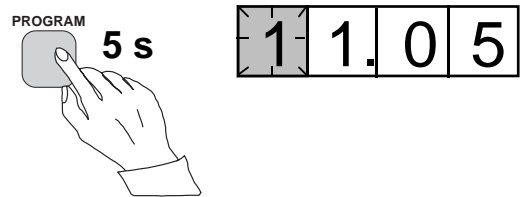

o) If the second setting is to be altered, enter submenu position 2 of the setting I> by pressing the STEP push button for approx. one second. The flashing position indicator 1 will then be replaced by a flashing number 2 which indicates that the setting shown on the display is the second setting for I>.

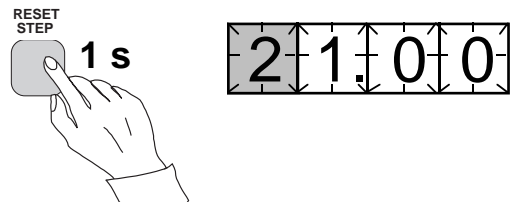

Enter the setting mode as in step c) and proceed in the same way. After recording of the requested values return to the main menu is obtained by pressing the STEP push button

until the first digit is switched off. The LED still shows that one is in the I> position and the display shows the new setting value currently in use by the relay module.

Example 2

Operation in the setting mode. Manual setting of the main setting of the checksum for the switchgroup SGF1 of a relay module. The initial value for the checksum is 000 and the switches

SGF1/1and SGF1/3 are to be set in position 1. This means that a checksum of 005 should be the final result.

a) Press push button STEP until the LED close to the SGF symbol is lit and the checksum appears on the display.

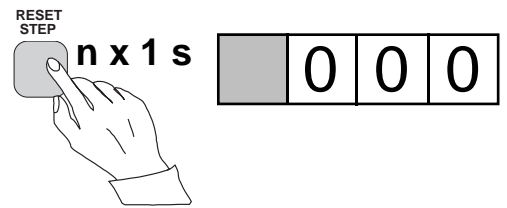

b) Enter the submenu to get the main checksum of SGF1 by pressing the PROGRAM push button for more than one second and then releasing it. The red display now shows a flashing number 1 indicating the first submenu position and the green digits show the checksum.

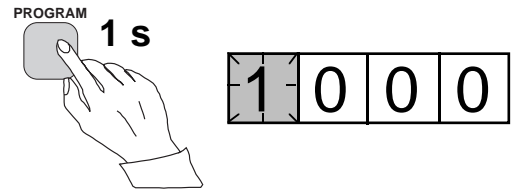

c) Enter the setting mode by pressing the PROGRAM push button for five seconds until the display starts flashing.

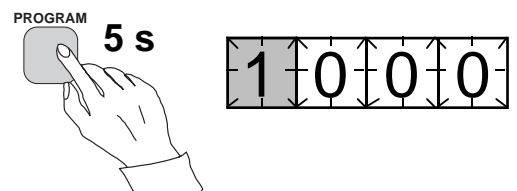

d) Press the PROGRAM push button once again to get the first switch position. The first digit of the display now shows the switch number. The position of the switch is shown by the rightmost digit.

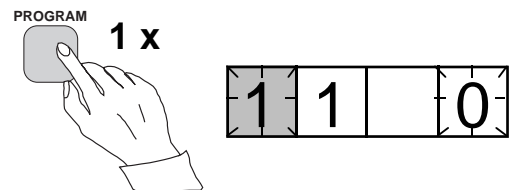

e) The switch position can now be toggled between 1 and 0 by means of the STEP push button and it is left in the requested position 1.

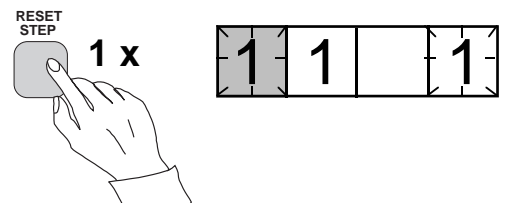

f) When switch number 1 is in the requested position, switch number 2 is called up by pressing the PROGRAM push button for one second. As in step e), the switch position can be altered by using the STEP push button. As the desired setting for SGF1/2 is 0 the switch is left in the 0 position.

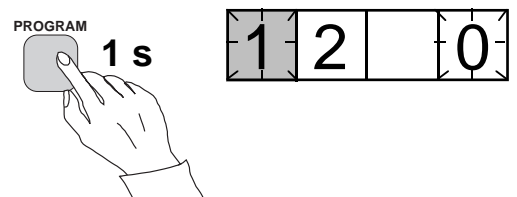

g) Switch SGF1/3 is called up as in step f) by pressing the PROGRAM push button for about one second.

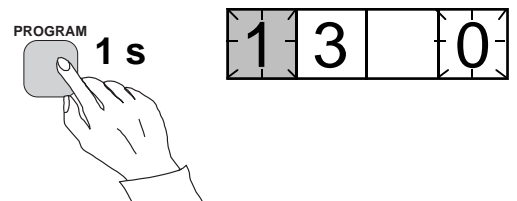

h)
The switch position is altered to the desired position 1 by pressing the STEP push button once.

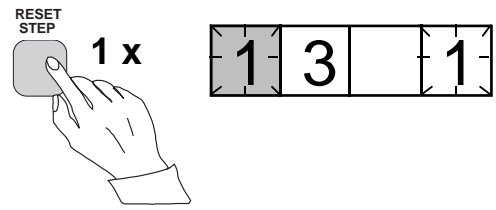

i)
Using the same procedure the switches SGF 1/4...8 are called up and, according to the example, left in position 0.

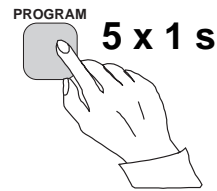

j)
In the final setting mode position, corresponding to step c), the checksum based on the set switch positions is shown.

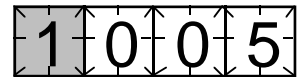

k)
If the correct checksum has been obtained, it is recorded in the memory by pressing the push buttons PROGRAM and STEP simultaneously. At the moment the information enters the memory, the green dashes flash in the display, i.e. 1 - - -. If the checksum is incorrect, the setting of the separate switches is repeated using the PROGRAM and STEP push buttons starting from step d).

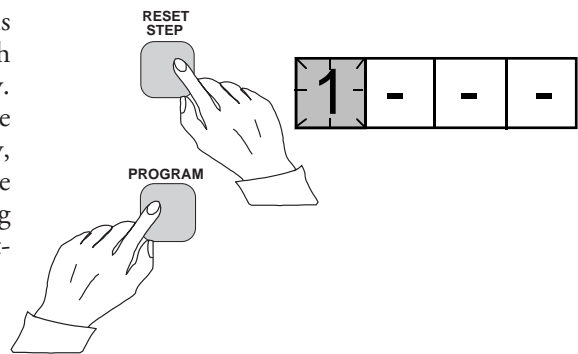

l)
Recording the new value automatically initiates a return from the setting mode to the normal menu. Without recording one can leave the setting mode any time by pressing the PROGRAM push button for about five seconds, until the green display digits stop flashing.

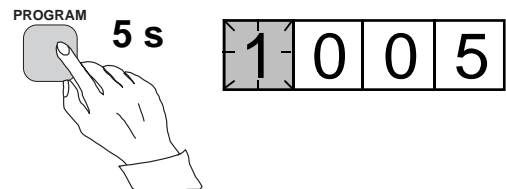

m)
After recording the desired values return to the main menu is obtained by pressing the STEP push button until the first digit is turned off. The LED indicator SGF still shows that one is in the SGF position and that the display shows the new checksum for SGF1 currently in use by the relay module.

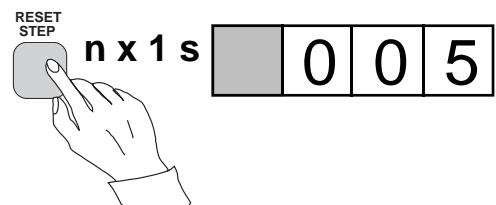

Recorded information

The parameter values measured at the moment when a fault occurs or at the trip instant are recorded in the registers. The recorded data, except for some parameters, are set to zero by pressing the push buttons STEP and PROGRAM simultaneously. The data in normal registers are erased if the auxiliary voltage supply to the relay is interrupted, only the set values and certain other essential parameters are maintained in non-volatile registers during a voltage failure.

The number of registers varies with different relay module types. The functions of the registers are illustrated in the descriptions of the different relay modules. Additionally, the system front panel of the relay contains a simplified list of the data recorded by the various relay modules of the protection relay.

All D type relay modules are provided with two general registers: register 0 and register A.

Register 0 contains, in coded form, the information about e.g. external blocking signals, status information and other signals. The codes are explained in the manuals of the different relay modules.

Register A contains the address code of the relay modul which is required by the serial communication system.

Submenu 1 of register A contains the data transfer rate value, expressed in kilobaud, of the serial communication.

Submenu 2 of register A contains a bus communication monitor for the SPAbus. If the protection relay, which contains the relay module, is linked to a system including a control data communicatoe, for instance SRIO 1000M and the data communication system is operating, the counter reading of the monitor will be zero. Otherwise the digits 1...255 are continuously scrolling in the monitor.

Submenu 3 contains the password required for changing the remote settings. The address code, the data transfer rate of the serial communication and the password can be set manually or via the serial communication bus. For manual setting see example 1.

The default value is 001 for the address code, 9.6 kilobaud for the data transfer rate and 001 for the password.

In order to secure the setting values, all settings are recorded in two separate memory banks within the non-volatile memory. Each bank is complete with its own checksum test to verify the condition of the memory contents. If, for some reason, the contents of one bank is disturbed, all settings are taken from the other bank and the contents from here is transferred to the faulty memory region, all while the relay is in full operation condition. If both memory banks are simultaneously damaged the relay will be set out of operation, and an alarm signal will be given over the serial port and the IRF output relay

Trip test function

Register 0 also provides access to a trip test function, which allows the output signals of the relay module to be activated one by one. If the auxiliary relay module of the protection assembly is in place, the auxiliary relays then will operate one by one during the testing.

When pressing the PROGRAM push button for about five seconds, the green digits to the right start flashing indicating that the relay module is in the test position. The indicators of the settings indicate by flashing which output signal can be activated. The required output function is selected by pressing the PROGRAM push button for about one second.

The indicators of the setting quantities refer to the following output signals:

| | |
|---------------|-----------------------|
| Setting I> | Starting of stage I> |
| Setting t> | Tripping of stage I> |
| Setting I>> | Starting of stage I>> |
| Setting t>> | Tripping of stage I>> |
| etc. | |
| No indication | Self-supervision IRF |

The selected starting or tripping is activated by simultaneous pressing of the push buttons STEP and PROGRAM. The signal remains activated as long as the two push buttons are pressed. The effect on the output relays depends on the configuration of the output relay matrix switches.

The self-supervision output is activated by pressing the STEP push button 1 second when no setting indicator is flashing. The IRF output is activated in about 1 second after pressing of the STEP push button.

The signals are selected in the order illustrated in Fig. 4.

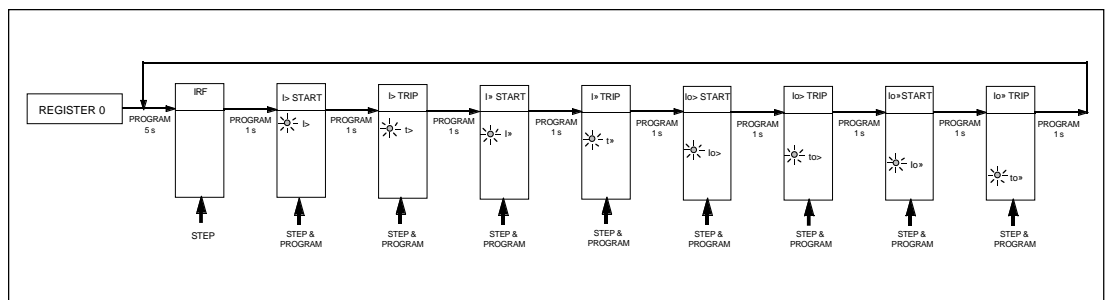

Fig. 5. Sequence order for the selection of output signals in the Trip test mode

If, for instance, the indicator of the setting t> is flashing, and the push buttons STEP and PROGRAM are being pressed, the trip signal from the low-set overcurrent stage is activated. Return to the main menu is possible at any stage of the trip test sequence scheme, by pressing the PROGRAM push button for about five seconds.

Note!
The effect on the output relays then depends on the configuration of the output relay matrix switchgroups SGR 1...3.

Example 3

Trip test function. Forced activation of the outputs.

- a)
Step forward on the display to register 0.

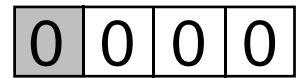
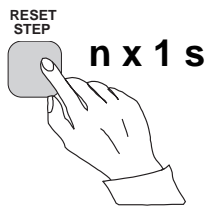

- b)
Press the PROGRAM push button for about five seconds until the three green digits to the right.

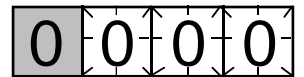
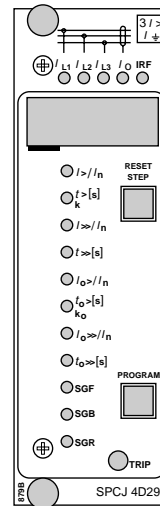

- c)
Hold down the STEP push button. After one second the red IRF indicator is lit and the IRF output is activated. When the step push button is released the IRF indicator is switched off and the IRF output resets.

- d)
Press the PROGRAM push button for one second and the indicator of the topmost setting start flashing.

- e)
If a start of the first stage is required, now press the push-buttons PROGRAM and STEP simultaneously. The stage output will be activated and the output relays will operate according to the actual programming of the relay output switchgroups SGR.

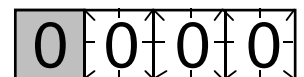
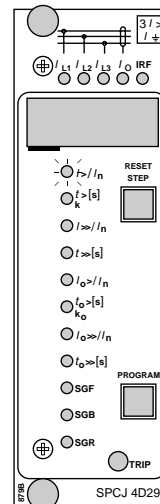
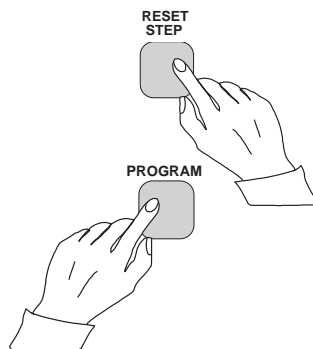

f)
To proceed to the next position press the PROGRAM push button for about 1 second until the indicator of the second setting starts flashing.

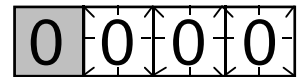
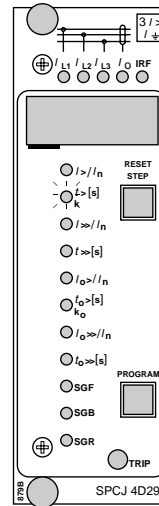

g)
Press the push buttons PROGRAM and STEP simultaneously to activate tripping of stage 1 (e.g. the I> stage of the overcurrent module SPCJ 4D29). The output relays will operate according to the actual programming of the relay switchgroups SGR. If the main trip relay is operated the trip indicator of the measuring module is lit.

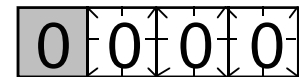
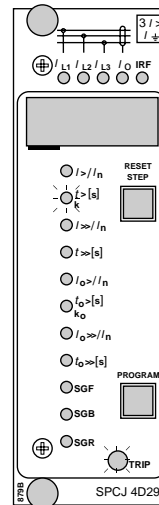
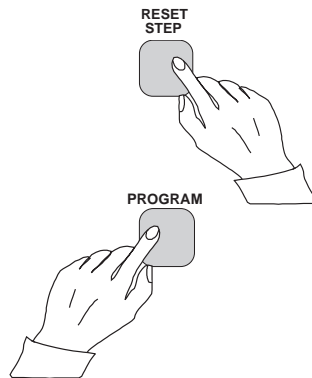

h)
The starting and tripping of the remaining stages are activated in the same way as the first stage above. The indicator of the corresponding setting starts flashing to indicate that the concerned stage can be activated by pressing the STEP and PROGRAM buttons simultaneously. For any forced stage operation, the output relays will respond according to the setting of the relay output switchgroups SGR. Any time a certain stage is selected that is not wanted to operate, pressing the PROGRAM button once more will pass by this position and move to the next one without carrying out any operation of the selected stage.

It is possible to leave the trip test mode at any step of the sequence scheme by pressing the PROGRAM push button for about five seconds until the three digits to the right stop flashing.

Operation indication

A relay module is provided with a multiple of separate operation stages, each with its own operation indicator shown on the display and a common trip indicator on the lower part of the front plate of the relay module.

The starting of a relay stage is indicated with one number which changes to another number when the stage operates. The indicator remains glowing although the operation stage resets. The

indicator is reset by means of the RESET push button of the relay module. An unreset operation indicator does not affect the function of the protection relay module.

In certain cases the function of the operation indicators may deviate from the above principles. This is described in detail in the descriptions of the separate modules.

Fault codes

In addition to the protection functions the relay module is provided with a self-supervision system which continuously supervises the function of the microprocessor, its program execution and the electronics.

Shortly after the self-supervision system detects a permanent fault in the relay module, the red IRF indicator on the front panel is lit. At the same time the module puts forward a control signal to the output relay of the self-supervision system of the protection relay.

In most fault situations a fault code, indicating the nature of the fault, appears on the display of

the module. The fault code, which consists of a red figure "1" and a three digit green code number, cannot be removed from the display by resetting. When a fault occurs, the fault code should be recorded and stated when service is ordered. When in a fault mode, the normal relay menus are operative, i.e. all setting values and measured values can be accessed although the relay operation is inhibited. The serial communication is also operative making it possible to access the relay information also from a remote site. The internal relay fault code shown on the display remains active until the internal fault possibly disappears and can also be remotely read out as variable V 169.



ABB Oy

Substation Automation

P.O.Box 699

FIN-65101 VAASA

Finland

Tel. +358 (0)10 22 11

Fax.+358 (0)10 22 41094

www.abb.com/substationautomation