

Effective: May 2009

Supersedes I.L. 41-100.1B, Dated November 1999

Type CO Overcurrent Relay Class 1E Application

(|) Denotes Change Since Previous Issue

CONTENTS

This instruction leaflet applies to the following types of relays:

Type CO-2	Short Time Relay
Type CO-5	Long Time Relay
Type CO-6	Definite Minimum Time Relay
Type CO-7	Moderately Inverse Time Relay
Type CO-8	Inverse Time Relay
Type CO-9	Very Inverse Time Relay
Type CO-11	Extremely Inverse Relay



CAUTION

Before putting relays into service, remove all blocking which may have been inserted for the purpose of securing the parts during shipment, make sure that all moving parts operate freely, inspect the contacts to see that they are clean and close properly, and operate the relay to check the settings and electrical connections.

1.0 APPLICATION

These relays have been specially designed and tested to establish their suitability for Class 1E applications in accordance with the ABB Relay Division program for Class 1E Qualification Testing as detailed in the ABB bulletin STR-1.

“Class 1E” is the safety classification of the electric equipment and systems in nuclear power generating stations that are essential to emergency shutdown of

the reactor, containment isolation, cooling of the reactor, and heat removal from the containment and reactor, or otherwise are essential in preventing significant release of radioactive material to the environment.

These induction overcurrent relays are used to disconnect circuits or apparatus when the current in them exceeds a given value. Where a station battery (48 volts or over) is available, the circuit closing type relays are normally used to trip the circuit breaker.

2.0 CONSTRUCTION AND OPERATION

The Type CO relays consists of an overcurrent unit (CO), an indicating contactor switch (ICS), and an indicating instantaneous trip unit (IIT) when required.

2.1 ELECTROMAGNET

The electromagnets for the Types CO-5, CO-6, CO-7, CO-8 and CO-9 relays have a main tapped coil located on the center leg of an “E” type laminated structure that produces a flux which divides and returns through the outer legs. A shading coil causes the flux through the left leg to lag the main pole flux. The out-of-phase fluxes thus produced in the air gap cause a contact closing torque. A torque controlled CO has the lag coil connections of the electromagnet brought out to separate terminals. This permits control of the closing torque such that only when these terminals are connected together will the unit operate.

All possible contingencies which may arise during installation, operation or maintenance, and all details and variations of this equipment do not purport to be covered by these instructions. If further information is desired by purchaser regarding this particular installation, operation or maintenance of this equipment, the local ABB representative should be contacted.

The electromagnets for the Types CO-2 and CO-11 relays have a main coil consisting of a tapped primary winding and a secondary winding. Two identical coils on the outer legs of the lamination structure are connected to the main coil secondary in a manner so that the combination of all the fluxes produced by the electromagnet result in out-of-phase fluxes in the air gap. The out-of-phase air gap fluxes produced cause a contact closing torque.

2.2 INDICATING CONTACTOR SWITCH UNIT (ICS)

The dc indicating contactor switch is a small clapper type device. A magnetic armature, to which leaf-spring mounted contacts are attached, is attracted to the magnetic core upon energization of the switch. When the switch closes, the moving contacts bridge two stationary contacts, completing the trip circuit. For double circuit closing contacts, the moving contacts bridge three stationary contacts. Also during this operation two fingers on the armature deflect a spring located on the front of the switch, which allows the operation indicator target to drop.

The front spring, in addition to holding the target, provides restraint for the armature and thus controls the pickup value of the switch.

2.3 INDICATING INSTANTANEOUS TRIP UNIT (IIT)

The instantaneous trip unit is a small ac operated clapper type device. A magnetic armature, to which leaf-spring mounted contacts are attached, is attracted to the magnetic core upon energization of the switch. When the switch closes, the moving contacts bridge two stationary contacts completing the trip circuit. For double circuit closing contacts, the moving contacts bridge three stationary contacts. Also, during the operation, two fingers on the armature deflect a spring located on the front of the switch which allows the operation indicator target to drop.

A core screw accessible from the top of the switch and taps on the coil provides the adjustable pickup range.

3.0 CHARACTERISTIC

The relays are generally available in the following current ranges:

Range	Taps
.5-2.5	0.5, 0.6, 0.8, 1.0, 1.5, 2.0, 2.5
1-12	1.0, 1.2, 1.5, 2.0, 2.5, 3.0, 3.5, 4.0, 5.0, 6.0, 7.0, 8.0, 10.0, 12.0

These relays may have either single or double circuit closing contacts for tripping either one or two circuit breakers. The relays are wired per the internal schematics on Figures 2 to 7 (pages 9 to 11).

The time vs. current characteristics are shown in Figures 9 to 15 (pages 13 to 19). These characteristics give the contact closing time for the various time dial settings when the indicated multiples of tap value current are applied to the relay. The time dial indicates starting position of the moving contact over a 270° range. Indexes from 1 (minimum time) to 11 (maximum time).

3.1 TRIP CIRCUIT

The main contacts will close 30 amperes at 250 volts dc and the seal-in contacts of the indicating contactor switch will carry this current long enough to trip a circuit breaker.

The indicating instantaneous trip contacts will close 30 amperes at 250 volts dc, and will carry this current long enough to trip a breaker.

3.2 TRIP CIRCUIT CONSTANTS

Indicating Contactor Switch Coil

Ampere Pickup	Ohms dc Resistance
0.2	8.5
1.0	0.37
2.0	0.10

4.0 SETTINGS

4.1 CO UNIT

The overcurrent unit setting can be defined by tap setting and time dial position or by tap setting and a specific time of operation at some current multiple of the tap setting (e.g., 4 tap setting, 2 time dial position or 4 tap setting, 0.6 seconds at 6 times tap value current). The tap setting is the minimum current required

to make the disc move.

To provide selective circuit breaker operation, a minimum coordinating time of 0.3 seconds plus circuit breaker time is recommended between the relay being set and the relays with which coordination is to be effected.

The connector screw on the terminal plate above the time dial makes connections to various turns on the operating coil. By placing this screw in the various terminal plate holes, the relay will respond to multiples of tap value currents in accordance with the various typical time-current curves.



Since the tap block connector screw on both the CO unit and IIT unit carries operating current, be sure that the screws are turned tight. Recommended tap screw tightening torque is 5 to 8 in-lbs.

In order to avoid opening current transformer circuits when changing taps under load, the relay must be first removed from the case. Chassis operating shorting switches on the case will short the secondary of the current transformer. The taps should then be changed with the relay outside of the case and then re-inserted into the case.

4.2 INSTANTANEOUS RECLOSING

The factory adjustment of the CO unit contacts provides a contact follow. Where circuit breaker reclosing will be initiated immediately after a trip by the CO contact, the time of the opening of the contacts should be a minimum. This condition is obtained by loosening the stationary contact mounting screw, removing the contact plate and then replacing the plate with the bent end resting against the contact spring.

For double trip relays, the upper stationary contact is adjusted such that the contact spring rests solidly against the backstop. The lower stationary contact is then adjusted such that both stationary contacts make simultaneously with their respective moving contact.

4.3 INDICATING CONTACTOR SWITCH (ICS)

There are no settings to make on the indicating con-

tactor switch (ICS).

4.4 INDICATING INSTANTANEOUS TRIP (IIT)

The proper tap must be selected and the core screw must be adjusted to the value of pick-up current desired.

The nameplate data will furnish the actual current range that may be obtained from the IIT unit. It is recommended that the IIT be set on the higher tap where there is a choice of tap settings. For example, for a 20 ampere setting use the 20 to 50 tap rather than the 6 to 20 tap.

5.0 INSTALLATION

The relays should be mounted on switchboard panels or their equivalent in a location free from dirt, moisture, excessive vibration and heat. Mount the relay vertically by means of the four mounting holes on the flange for the semi-flush Type FT case. The mounting screws may be utilized for grounding the relay. External toothed washers are provided for use in the locations shown on the outline and drilling plan to facilitate making a good electrical connection between the relay case, its mounting screws and the relay panel. Ground wires should be affixed to the mounting screws as required for poorly grounded or Insulating panels. Other electrical connections may be made directly to the terminals by means of screws for steel panel mounting.

For detail information on the FT case refer to Instruction Leaflet 41-076 for semi-flush mounting.

6.0 ADJUSTMENTS AND MAINTENANCE

Proper adjustments have been made at the factory. Upon receipt of the relay no customer adjustments, other than those covered under section 4.0 "SETTINGS" (page 2) should be required.

For relays which include an indicating instantaneous trip unit (IIT), the junction of the induction and indicating instantaneous trip coil is brought out of switch jaw No. 3. With this arrangement the overcurrent units can be tested separately.

6.1 PERFORMANCE CHECK

The following check is recommended to verify that

the relay is in proper working order.

6.1.1 CO UNIT

Contact

The index mark on the movement frame will coincide with the "0" mark on the time dial when the stationary contact has moved through approximately one-half of its normal deflection. Therefore, with the stationary contact resting against the backstop, the index mark is offset to the right of the "0" mark by approximately .020". The placement of the various time dial positions in line with the index mark will give operating times as shown on the respective current curves.

Settings – Overcurrent Unit

The 0.5 - 2.5 ampere range CO Relay should be set on the **lowest** tap for these tests. The 1 to 12 amp. range CO relay should be set on the 2 amp tap with the exception of the 1 - 12 ampere range CO-2 which should be set on the 1 ampere tap.

Minimum Trip Current

Set the time dial to position 6 using the **lowest** tap setting, alternately apply tap value current plus 3% and tap value current minus 3%. The moving contact should leave the backstop at tap value current plus 3% and should return to the backstop at tap value current minus 3%.

time Curve

For Type CO-11 relay only, the 1.30 times tap value operating time from the number 6 time dial position is $54.9 \pm 5\%$ seconds and should be checked first. It is important that the 1.30 times tap value current be maintained accurately. The maintaining of this current accurately is necessary because of the steepness of the slope of the time-current characteristic (Figure 15). A slight variation, $\pm 1\%$, in the 1.3 times tap value current (including measuring instrument deviation) will change the timing tolerance to $\pm 10\%$ of the effects of different taps can make the total variations appear to be $\pm 15\%$.

Table 1 (page 7) shows the time curve calibration points for the various types of relays. With the time dial set to the indicated position apply the currents specified by Table 1, (e.g. for the CO-8, 2 and 20 times tap value current) and measure the operating time of the relay.

The operating times should equal those of Table 1 plus or minus 5%.

6.1.2 INDICATING INSTANTANEOUS TRIP UNIT (IIT)

The core screw which is adjustable from the top of the trip unit and the tap located on the top of the IIT determines the pickup value. The trip unit has a nominal ratio of adjustment of 1 to 24.

Apply sufficient current to operate the IIT. The operation indicator target should drop freely.

6.1.3 INDICATING CONTACTOR SWITCH (ICS)

Close the main relay contacts and pass sufficient dc current through the trip circuit to close the contacts of the ICS. This value of current should not be greater than the particular ICS nameplate rating. The indicator target should drop freely.

Repeat above except pass 85% of ICS nameplate rating current. Contacts should not pickup the target should not drop.

7.0 ROUTINE MAINTENANCE

All relays should be inspected periodically. They should receive a "Performance Check" at least once every year or at such other time intervals as may be dictated by experience to be suitable to the particular application. A minimum suggested check on the relay system is to close the contacts manually so that the breaker trips and the target drops. Then release the contacts and observe that the reset is smooth and positive.

If an additional time check is desired, pass test current through the relay and check the time of operation. It is preferable to make this at several times pick-up current at an expected operating point for the particular application. For the 0.5 to 2.5 ampere range CO-5 and CO-6 induction unit use the alternative test circuit in Figure 16 (page 20) as these relays are affected by a distorted waveform. With this connection the 25/5 ampere current transformers should be worked well below the knee of the saturation (i.e., use 10L50 or better).

All contacts should be checked and cleaned if necessary. A contact burnisher No. 182A836H01 is recommended for this purpose. The use of abrasive

material for cleaning contacts is not recommended, because of the danger of embedding small particles in the face of the soft silver and thus impairing the contact.

8.0 CALIBRATION

Use the following procedure for calibrating the relay if the relay has been taken apart for repairs or the adjustments disturbed. This procedure should not be used until it is apparent that the relay is not in proper working order. (See "Performance Check", page 3.)

NOTE: A spring shield covers the reset spring of the CO relay. To remove the spring shield, requires that the damping magnet be removed first. The screw connection holding the lead to the moving contact should be removed next. The second screw holding the moving contact assembly should than be loosened but not removed. (CAUTION: This screw terminates into a nut held captive beneath the molded block. If screw is removed, difficulty will be experienced in the re-assembly of the moving contact assembly.) Slide the spring shield outward and remove from relay. Tighten the screw holding the moving contact assembly to the molded block.

8.1 CO UNIT

Contact

The index mark on the movement frame will coincide with the "0" mark on the time dial when the stationary contact has moved through approximately one-half of its normal deflection. Therefore, with the stationary contact resting against the backstop, the index mark is offset to the right of the "0" mark by approximately .020". The placement of the various time dial positions in line with the index mark will give operating times as shown on the respective timecurrent curves.

Setting – Overcurrent Unit

To minimize timing errors due to such factors as different taps and self heating of CO coil, the following taps are recommended in the calibration of the various CO relays.

Set the 0.5 to 2.5 range CO relay on the minimum tap setting. Set the 1 - 12 ampere range CO relay on the 2 amp tap with the exception of the 1 - 12 ampere range CO-2 relay which should be set on the 1 ampere tap.

Minimum Trip Current

The adjustment of the spring tension in setting the minimum trip current value of the relay is most conveniently made with the damping magnet removed.

With the time dial set on "0", wind up the spiral spring by means of the spring adjuster until approximately 6-3/4 convolutions show.

The spiral spring can be adjusted with the spring shield in place as follows. One slot of the spring adjuster will be available for a screwdriver in one window of the front barrier of the spring shield. By adjusting this slot until a barrier of the spring shield prevents further adjustment, a second slot of the spring adjustment will appear in the window on the other side of the spring shield barrier. Adjusting the second slot in a similar manner will reveal a third slot in the opposite window of the spring shield.

Adjust the control spring tension so that the moving contact will leave the backstop at tap value current +1.0% and will return to the backstop at tap value current -1.0%.

Time Curve Calibration

Install the permanent magnet. Apply the indicated current per Table 1 for permanent magnet adjustment (e.g. CO-8, 2 times tap value) and measure the operating time. Adjust the permanent magnet keeper until the operating time corresponds to the value of Table 1.

For Type CO-11 relay only, the 1.30 times tap value operating time from the number 6 time dial position is $54.9 \pm 5\%$ seconds. It is important that the 1.30 times tap value current be maintained accurately. The maintaining of this current accurately is necessary because of the steepness of the slope of the time-current characteristic (Figure 15). A slight variation, $\pm 1\%$, in the 1.3 times tap value current (including measuring instrument deviation) will change the timing tolerance to $\pm 10\%$ and the effect of different taps can make the total variations appear to be $\pm 15\%$. If the operating time at 0.13 times tap value is not within these limits, a minor adjustment of the control spring will give the correct operating time without any undue effect on the minimum pick-up of the relay. This check is to be made after the 2 times tap value adjustment has been made.

Apply the indicated current per Table 1 for the electromagnet plug adjustment (e.g. CO-8, 20 times tap value) and measure the operating time. Adjust the proper plug until the operating time corresponds to the value in Table 1. (Withdrawing the left hand plug, front view, increases the operating time and withdrawing the right hand plug, front view, decreases the time.) In adjusting the plugs, one plug should be screwed in completely and the other plug turned in or out until the proper operating time has been obtained.

Recheck the permanent magnet adjustment. If the operating time for this calibration point has changed, readjust the permanent magnet and then recheck the electromagnet plug adjustment.

8.2 INDICATING CONTACTOR SWITCH (ICS)

Initially adjust unit on the pedestal so that armature fingers do not touch the yoke in the reset position. (Viewed from top of switch between cover and frame.) This can be done by loosening the mounting screw in the molded pedestal and moving the ICS in the downward position.

- a. **Contact Wipe** – Adjust the stationary contact so that both stationary contacts make with the moving contacts simultaneously and wipe 1/64" to 3/64" when the armature is against the core.
- b. **Target** – Manually raise the moving contacts and check to see that the target drops at the same time as the contacts make or up to 1/16" ahead. The cover may be removed and the tab holding the target reformed slightly if necessary. However, care should be exercised so that the target will not drop with a slight jar.
- c. **Pickup** – The unit should pickup at 98% rating and not pickup at 85% of rating. If necessary, the cover leaf springs may be adjusted. To lower the pickup current use a tweezer or similar tool and squeeze each leaf spring approximately equal amounts by applying the tweezer between the leaf spring and the front surface of the cover at the bottom of the lower window.

If the pickup is low, the front cover must be removed and the leaf spring bent outward equally.

8.3 INDICATING INSTANTANEOUS TRIP (IIT)

Initially adjust unit on the pedestal so that armature fingers do not touch the yoke in the reset position. (Viewed from top of switch between cover and frame.) This can be done by loosening the mounting screw in the molded pedestal and moving the IIT in the downward position.

- a. **Contact wipe** – Adjust the stationary contacts so that both stationary contacts make with the moving contacts simultaneously and wipe 1/4" to 3/64" when the armature is against the core. This can be accomplished by inserting a .0125 thick gage between the armature and case and adjusting the stationary contacts until they just touch the moulding.
- b. **Target** – Manually raise the moving contacts and check to see that the target drops at the same time as the contacts make or up to 1/16" ahead. The cover may be removed and the tab holding the target reformed slightly if necessary. However, care should be exercised so that the target will not drop with a slight jar.
- c. **Pickup** – Place tap screw in the 6 to 20 tap and turn the core screw all the way in. Contacts should pickup at a value of current less than 6 amperes but not lower than 5.1 amperes. If pickup is above this range, it may be reduced by using a tweezer or similar tool and squeezing each leaf spring approximately equal amounts by applying the tweezer between the leaf spring and the front surface of the cover at the bottom of the lower window. If the pick is below range it may be increased by removing the front cover and bending the leaf spring outward equally. An approximate adjustment would be when the end of the leaf spring is in line with the edge of the molded cover. The described pickup is obtained by setting the tap screw in the proper range and adjusting the core screw.

9.0 RENEWAL PARTS

Repair work can be done most satisfactorily at the factory. However, interchangeable parts can be furnished to customers who are equipped for doing repair work. When ordering parts always give the complete nameplate information.

Table 1:
TIME CURVE CALIBRATION DATA – 60 Hertz

PERMANENT MAGNET ADJUSTMENT			
Relay Type	Time Dial Position	Current (Multiples of Tap Value)	Operating Time Seconds
CO-2	6	3	0.57
CO-5	6	2	37.80
CO-6	6	2	2.46
CO-7	6	2	4.27
CO-8	6	2	13.35
CO-9	6	2	8.87
CO-11	6	2	11.27
ELECTROMAGNET PLUGS			
CO-2	6	20	0.22
CO-5	6	10	14.30
CO-6	6	20	1.19
CO-7	6	20	1.11
CO-8	6	20	1.11
CO-9	6	20	0.65
CO-11	6	20	0.24

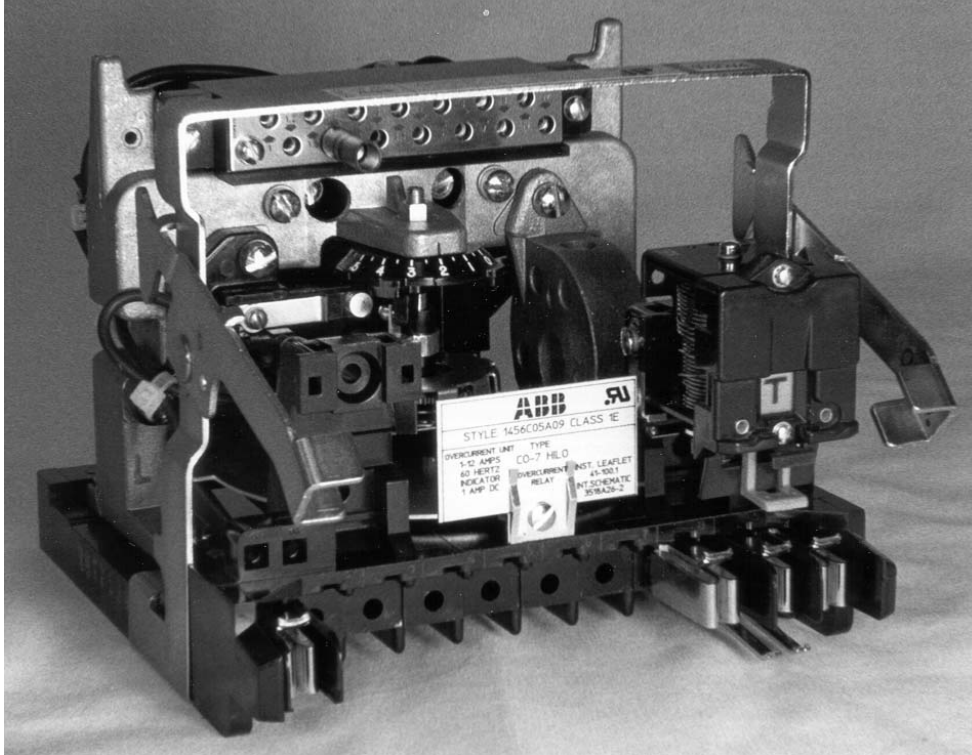

Front View Photo 9664A52

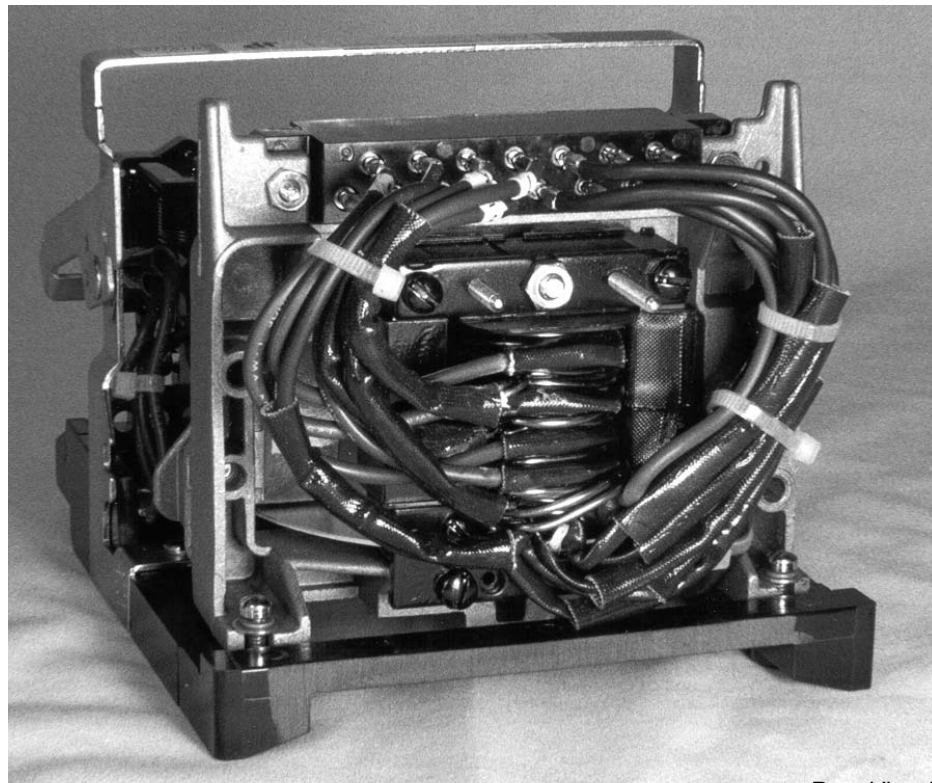

Rear View Photo 9664A53

Figure 1: CO Overcurrent Relay (Class 1E)

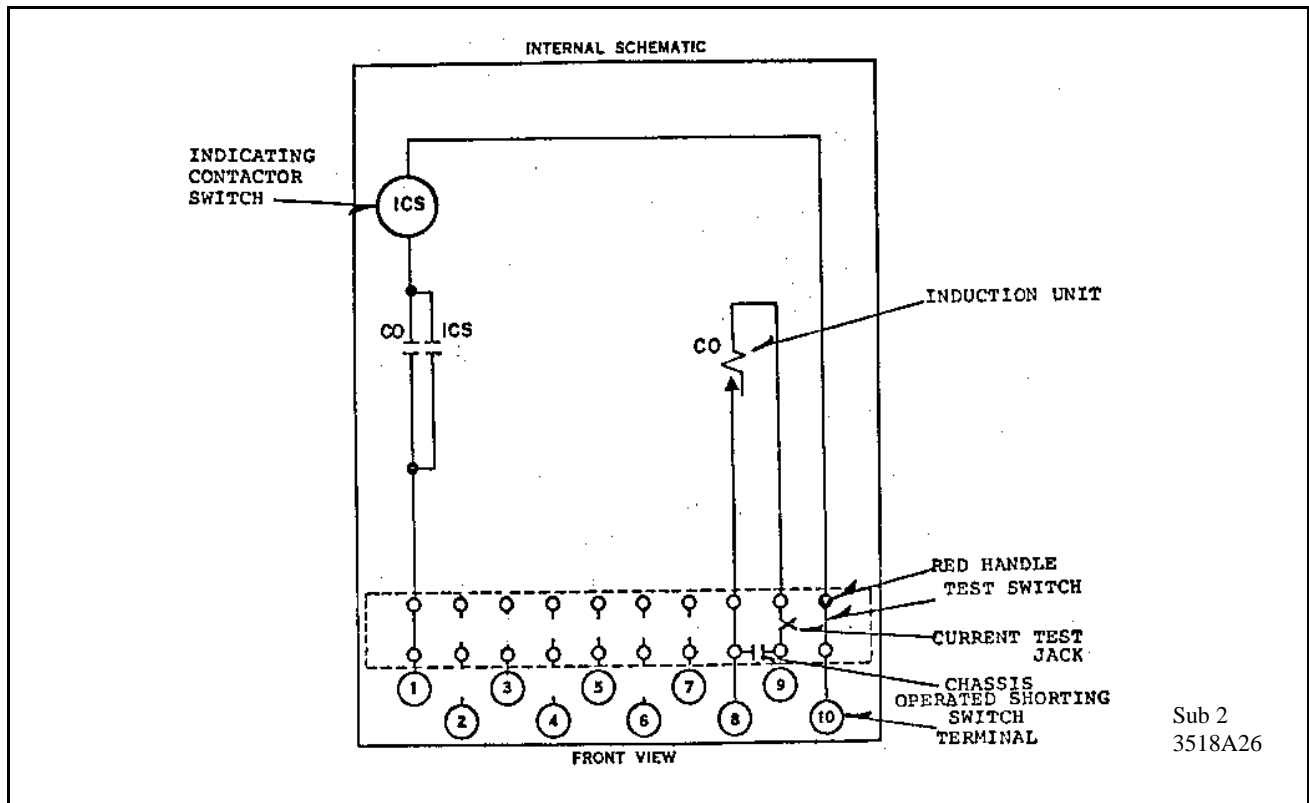

Figure 2: Internal Schematic Of The Single Trip Relay Without IIT

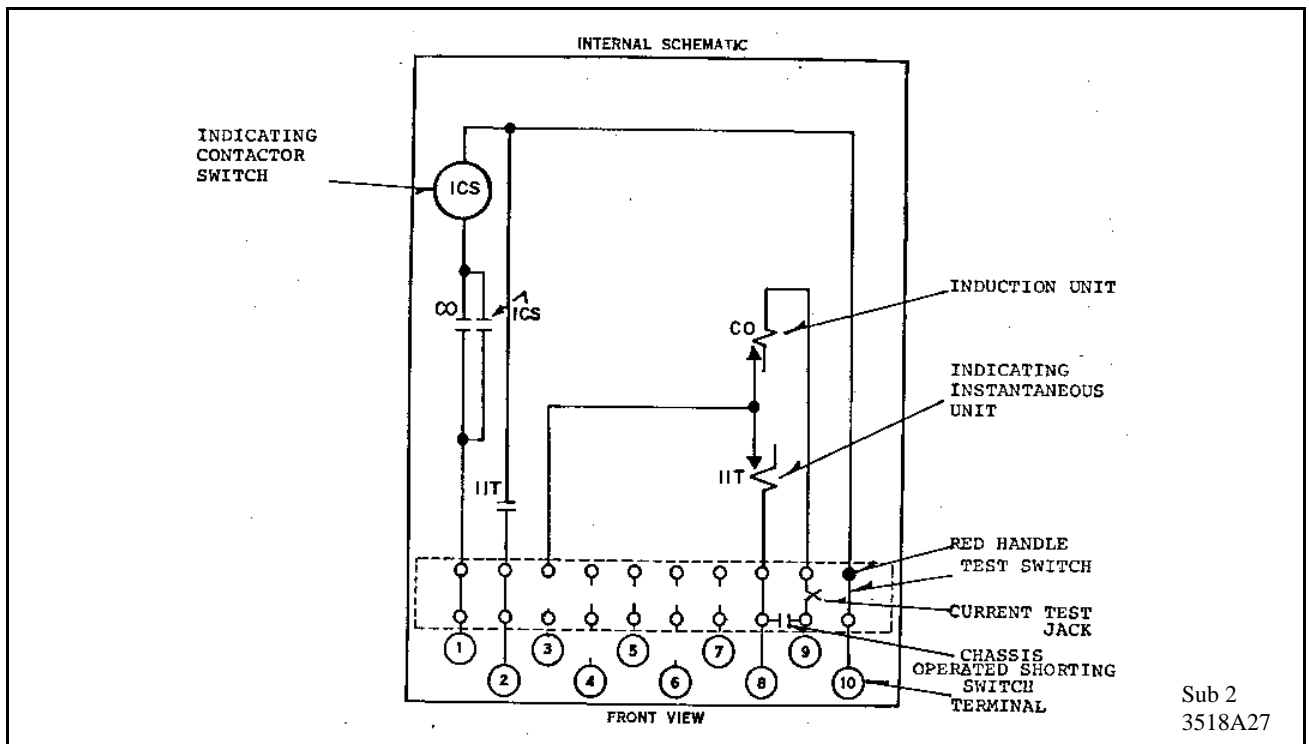

Figure 3: Internal Schematic of the Single Trip Relay with IIT

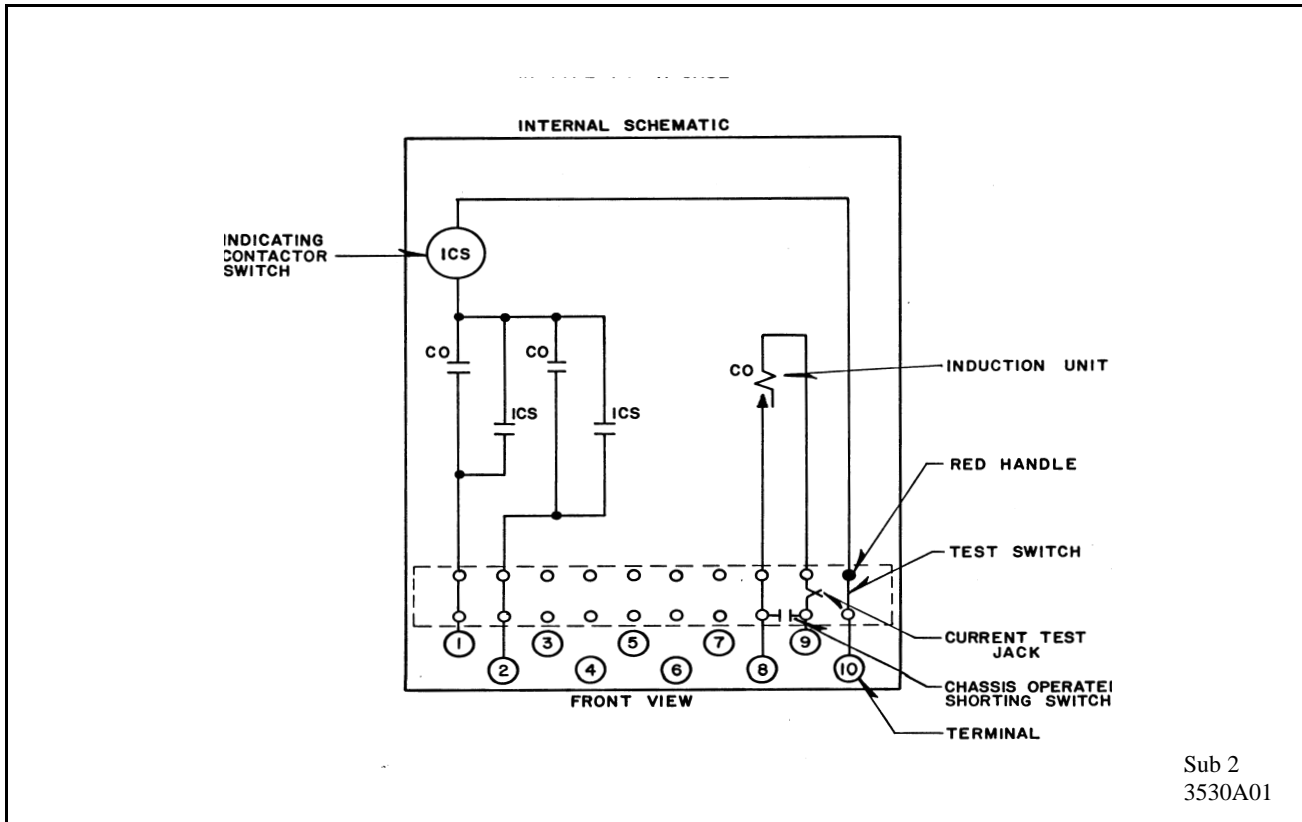

Figure 4: Internal Schematic of the Double Trip Relay without IIT

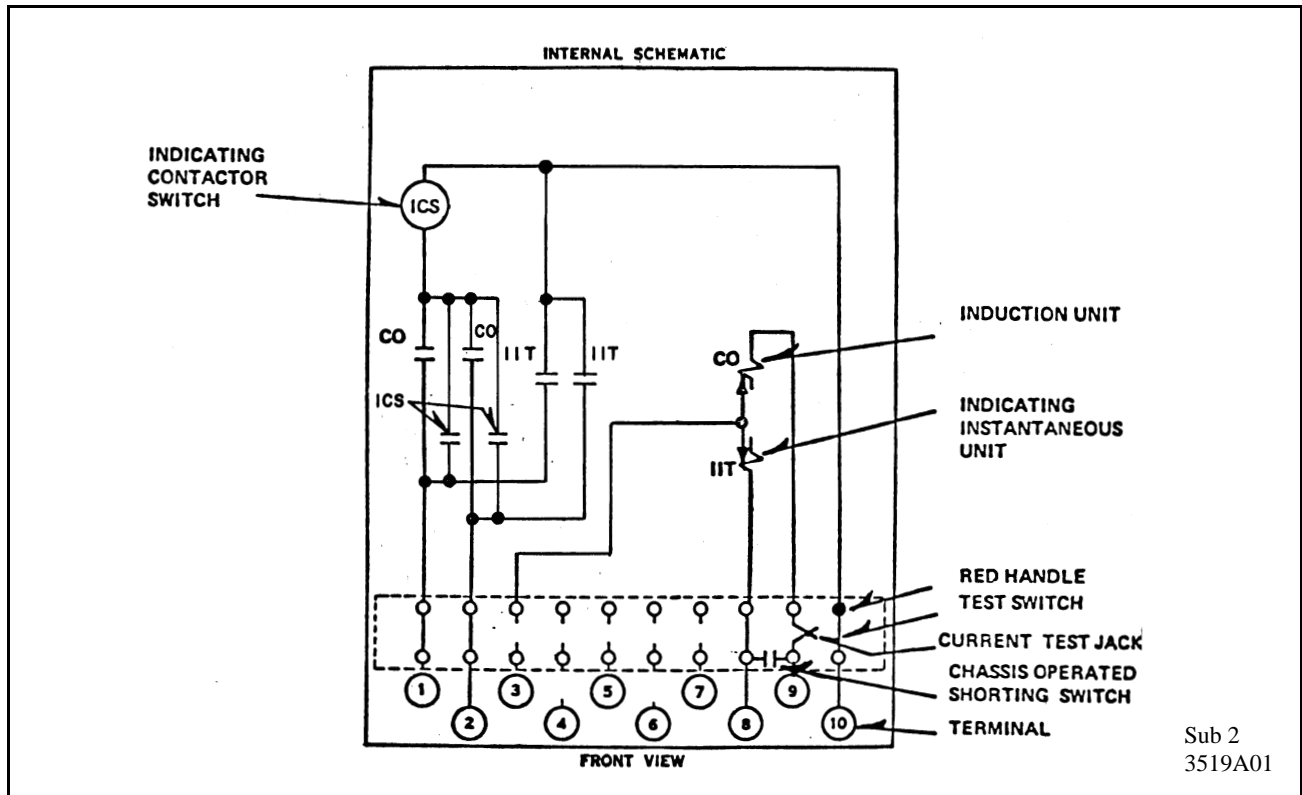

Figure 5: Internal Schematic of the Double Trip Relay with IIT

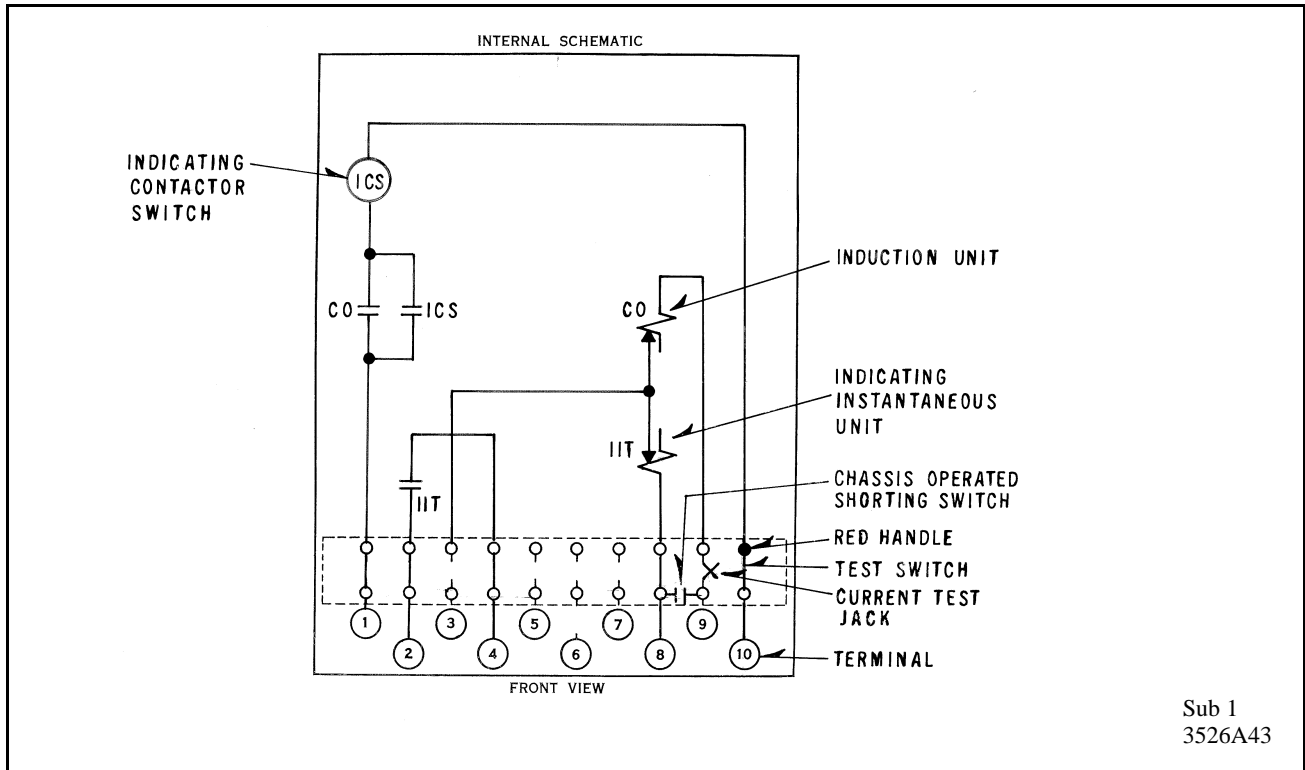

Figure 6: Internal Schematic of the Single Trip Relay with IIT Contacts to Separate Terminals

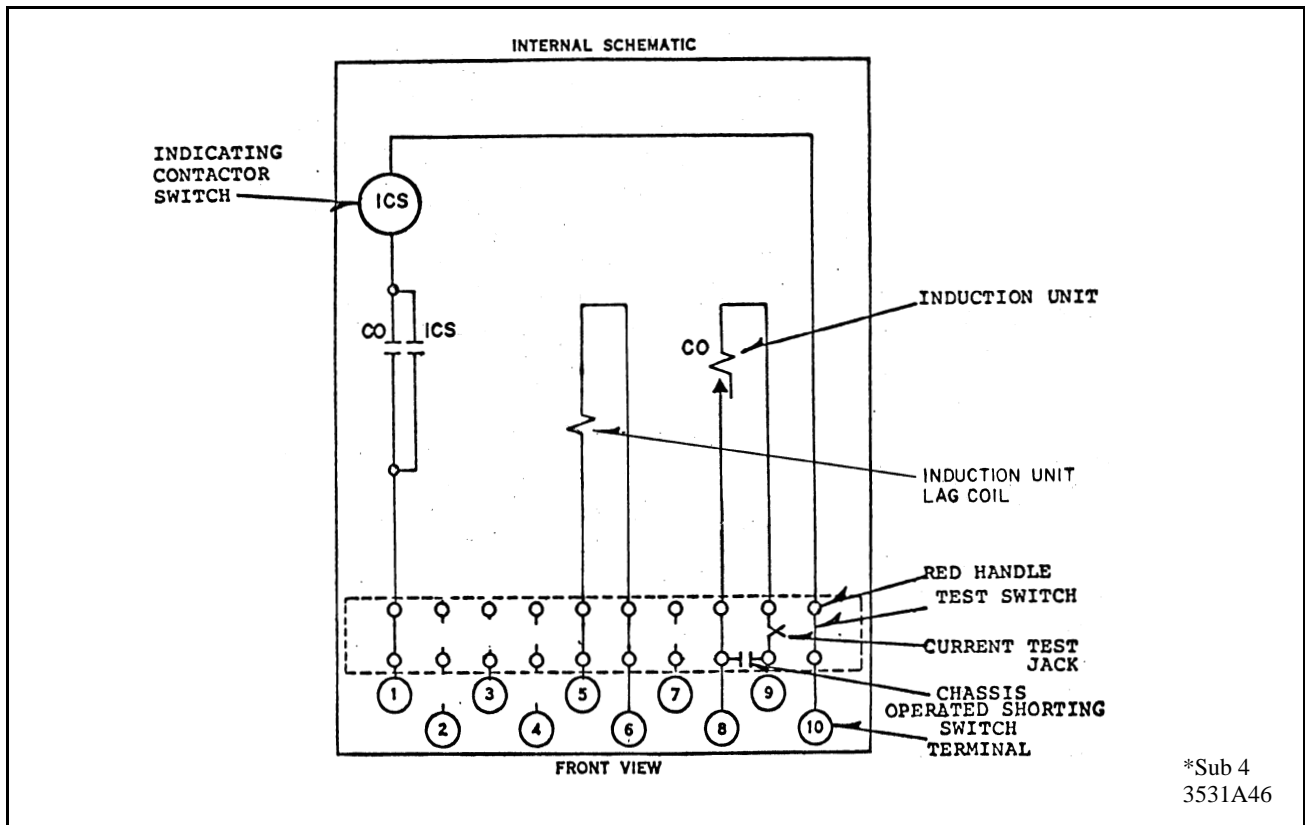

Figure 7: Internal Schematic of Single Trip Relay with Torque Control Terminals without IIT

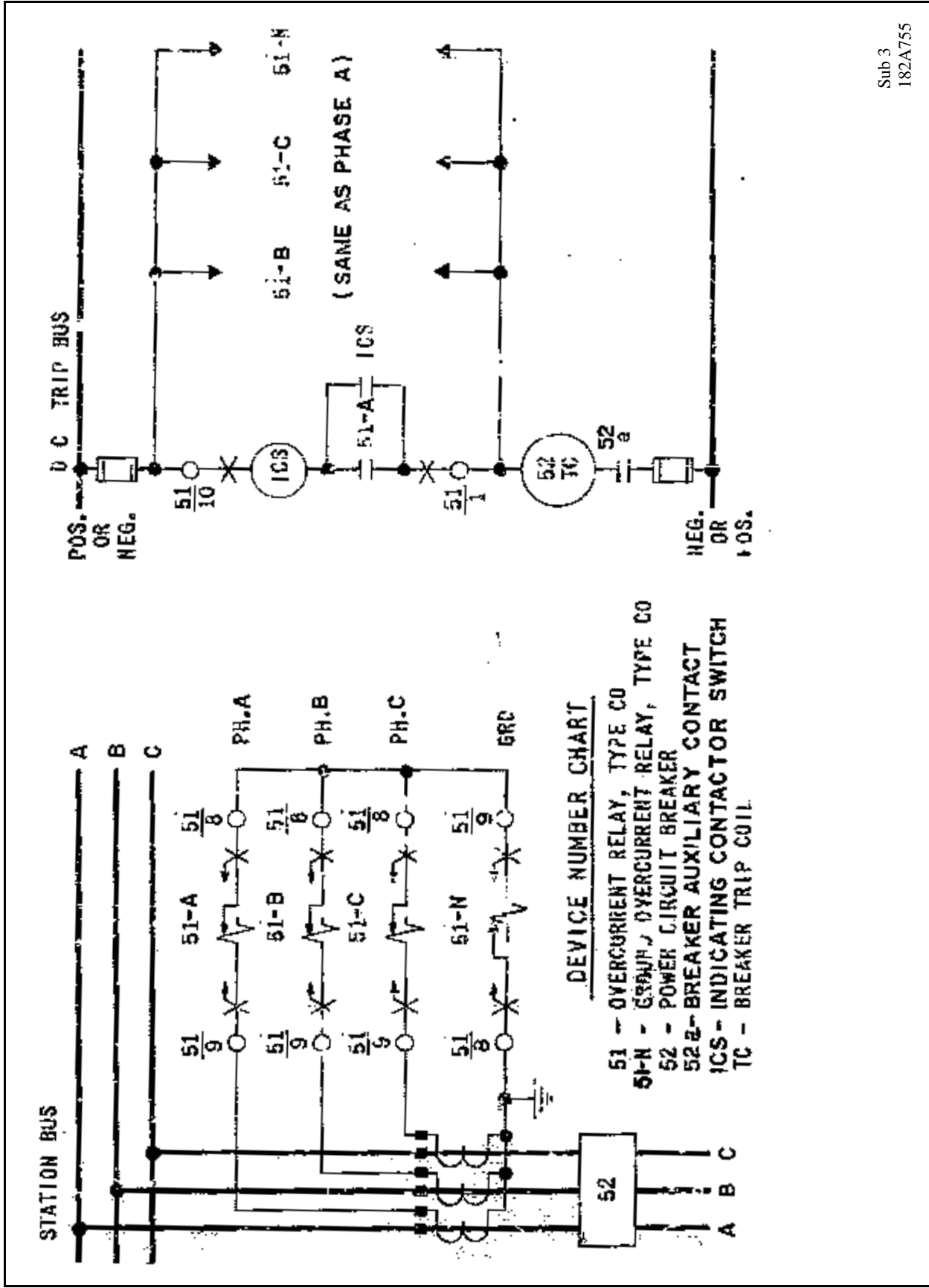

Figure 8: External Schematic of CO Relay for Phase and Ground Overcurrent Protection on a Three Phase System

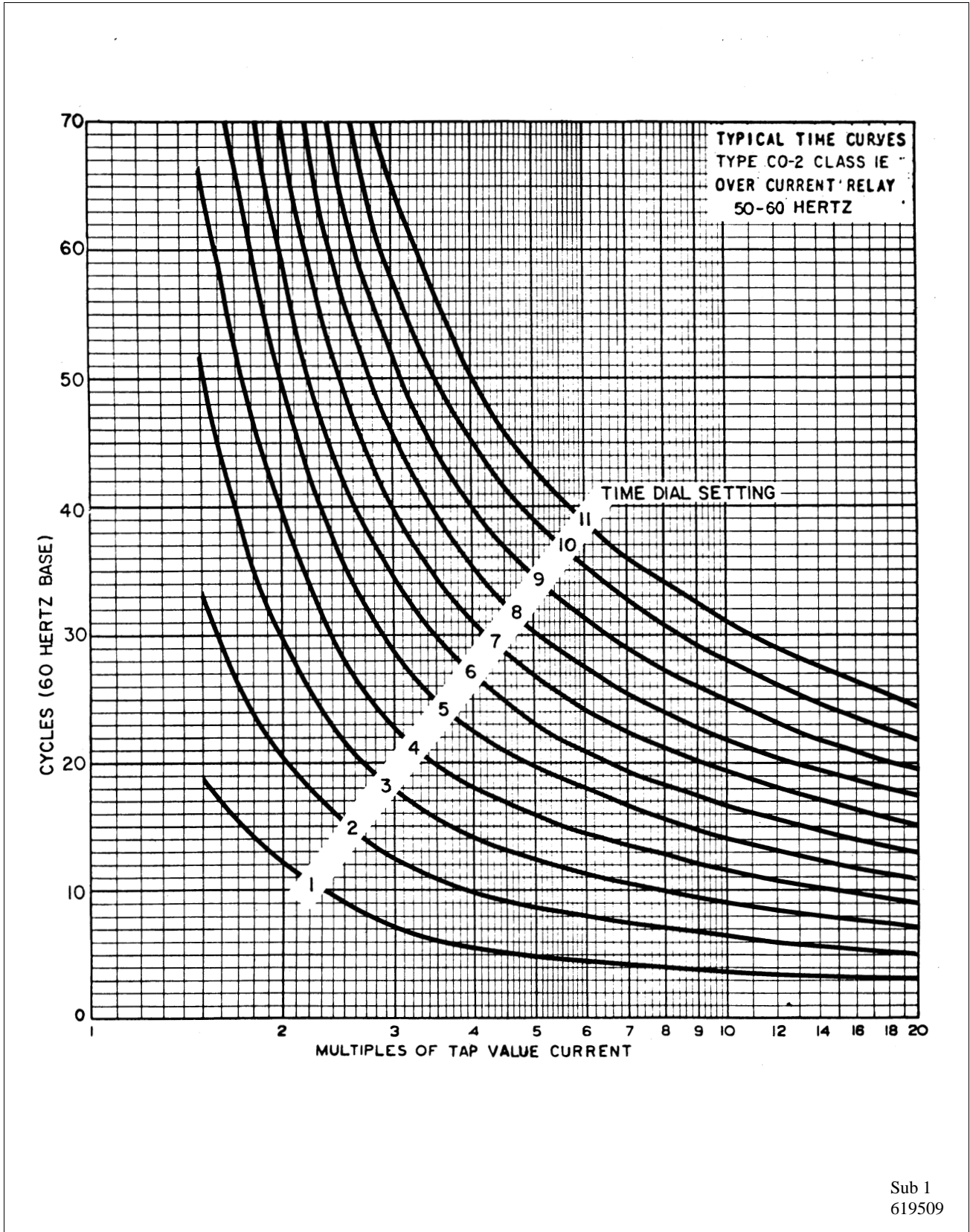
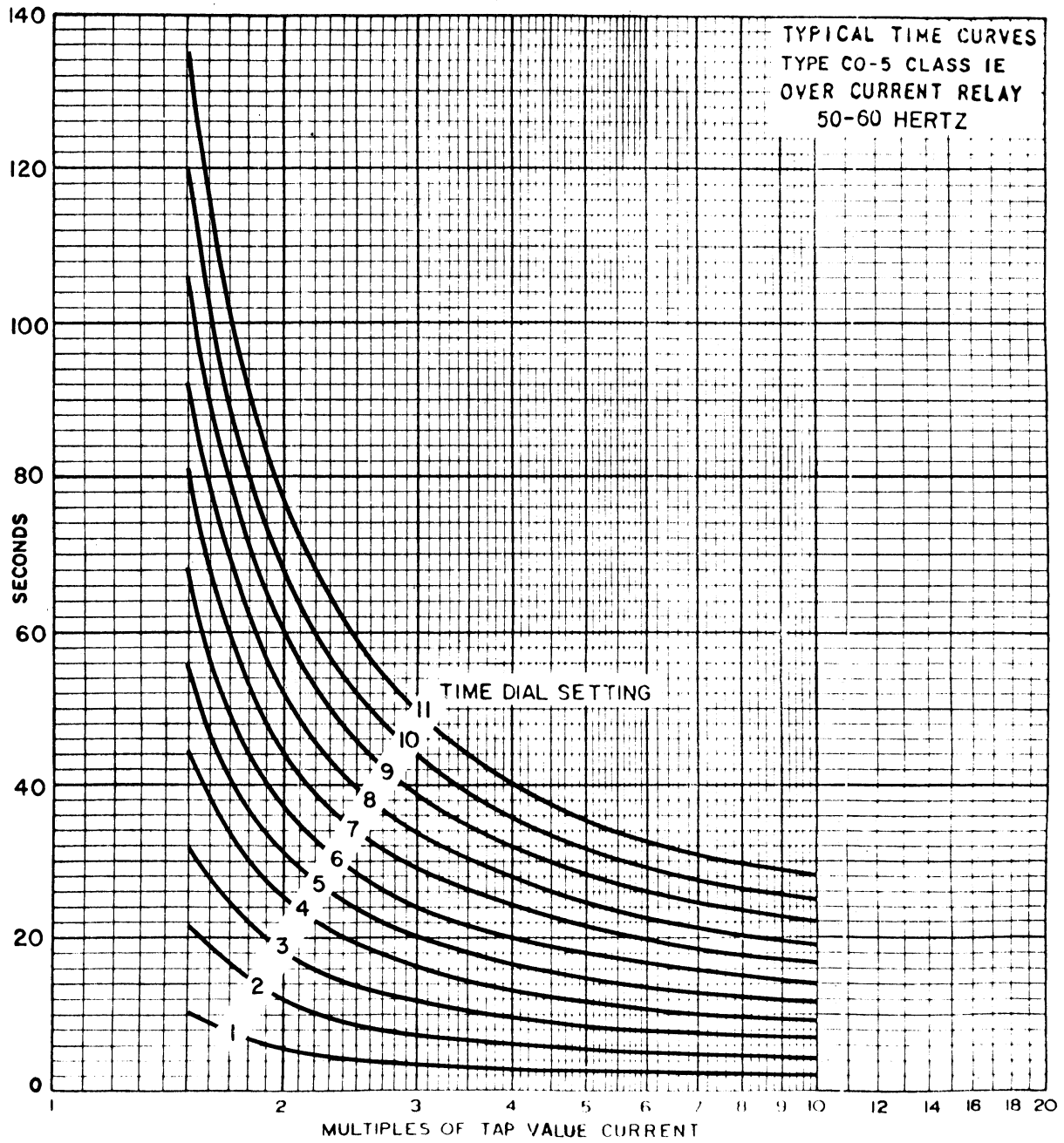

Figure 9: Typical Time Curve of the Type CO-2 Relay

Sub 1
619509



Sub 1
619510

Figure 10: Typical Time Curve of the Type CO-5 Relay

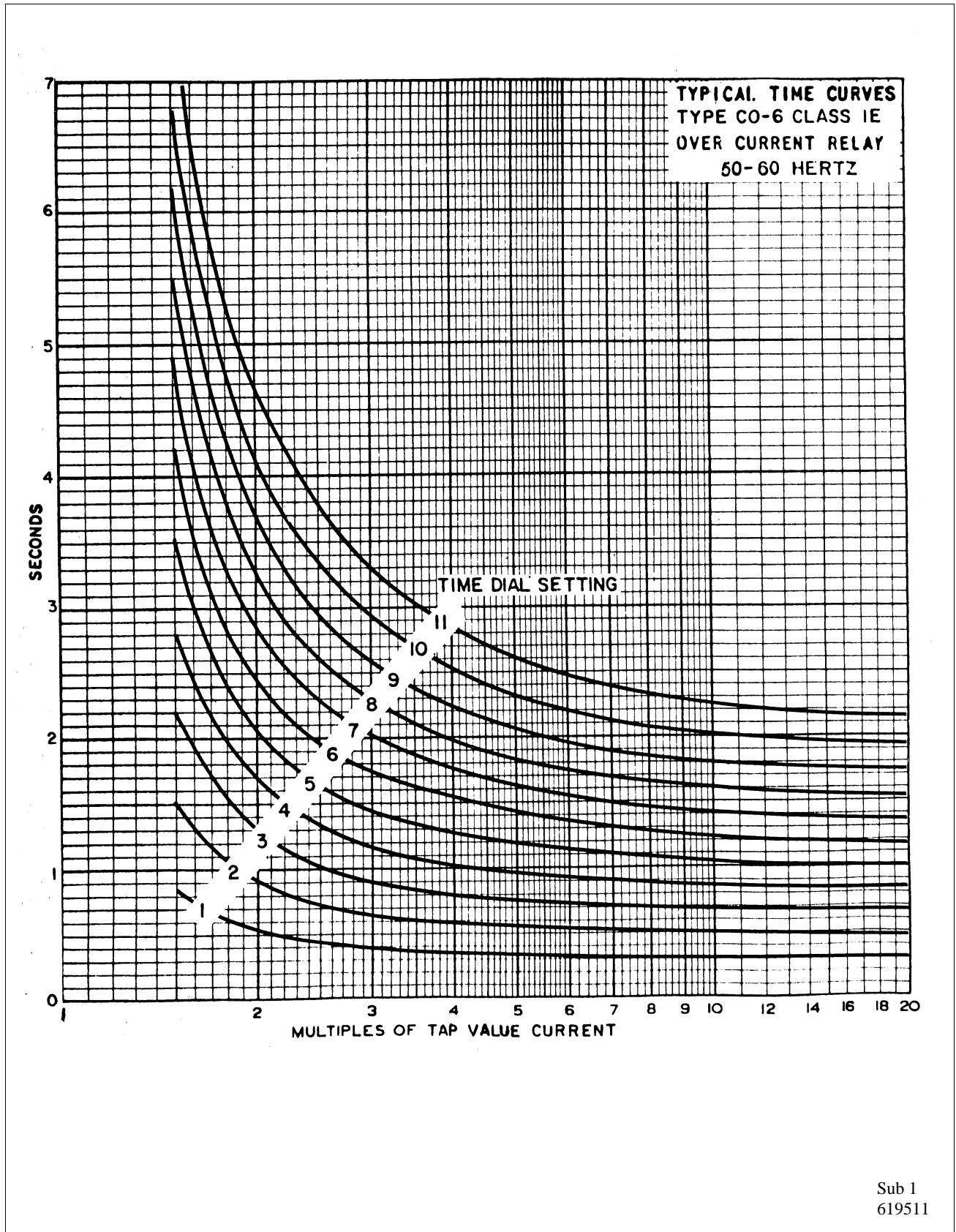
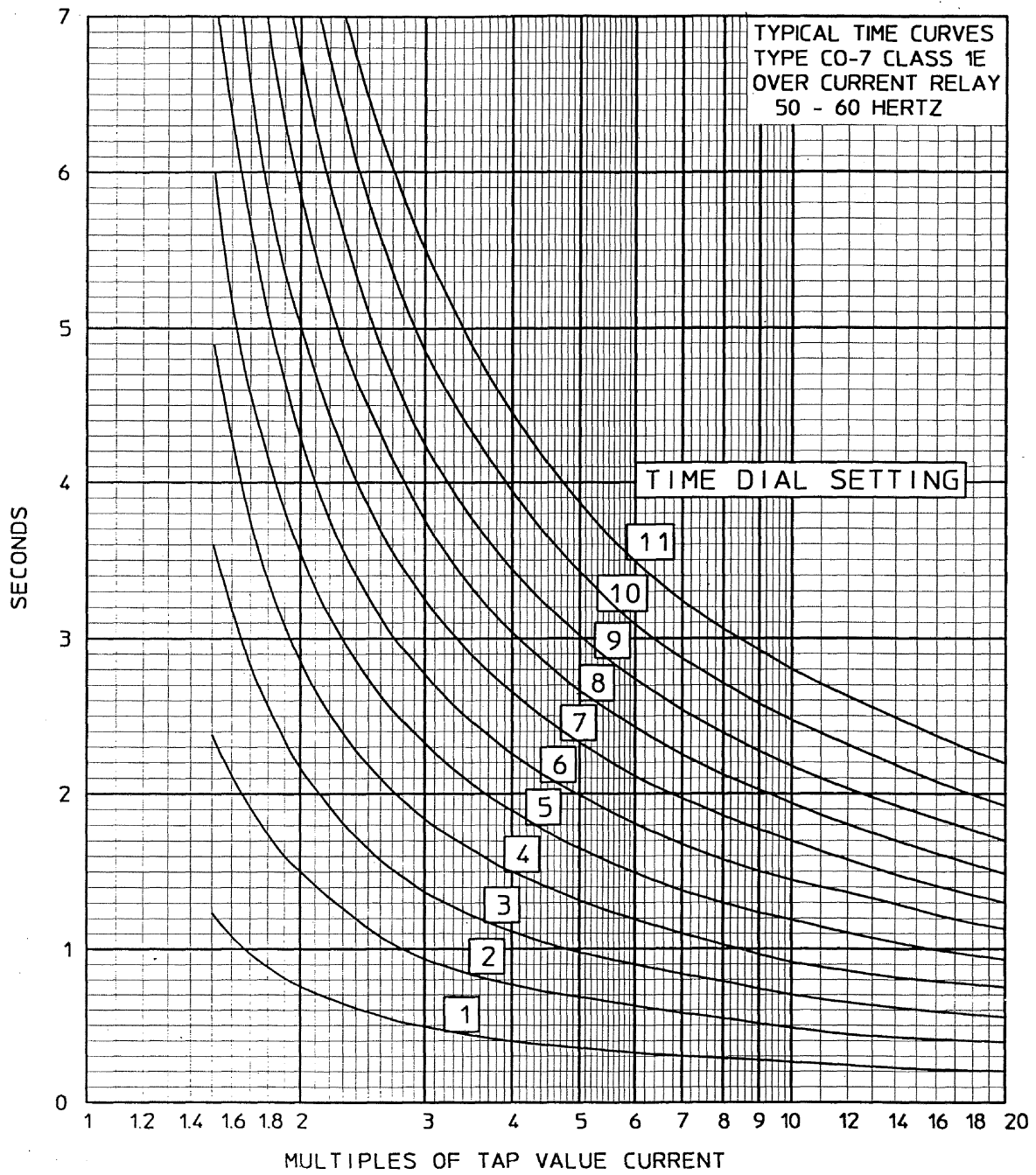
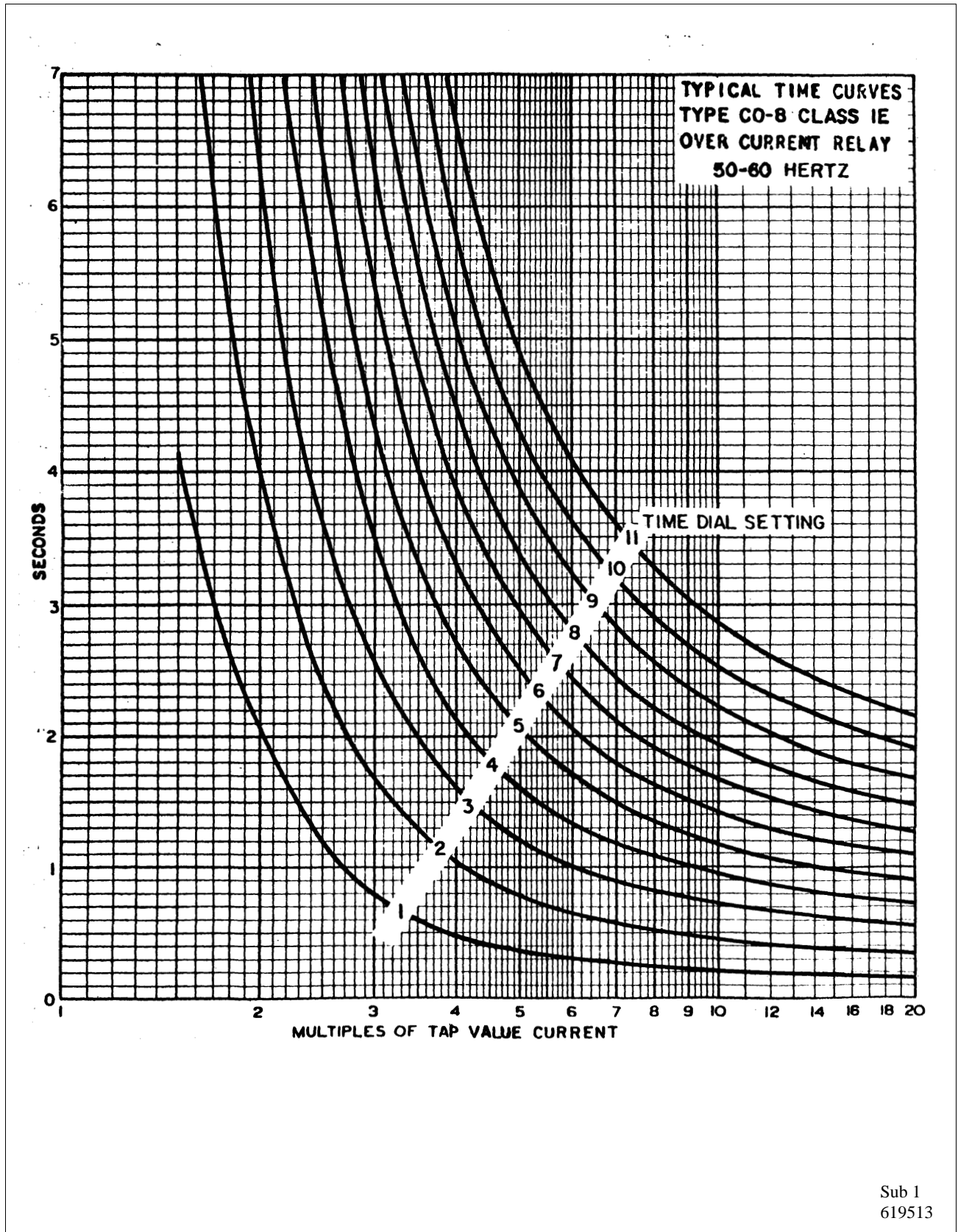

Figure 11: Typical Time Curve of the Type CO-6 Relay



Sub 2
619512

Figure 12: Typical Time Curve of the Type CO-7 Relay



Sub 1
619513

Figure 13: Typical Time Curve of the Type CO-8 Relay

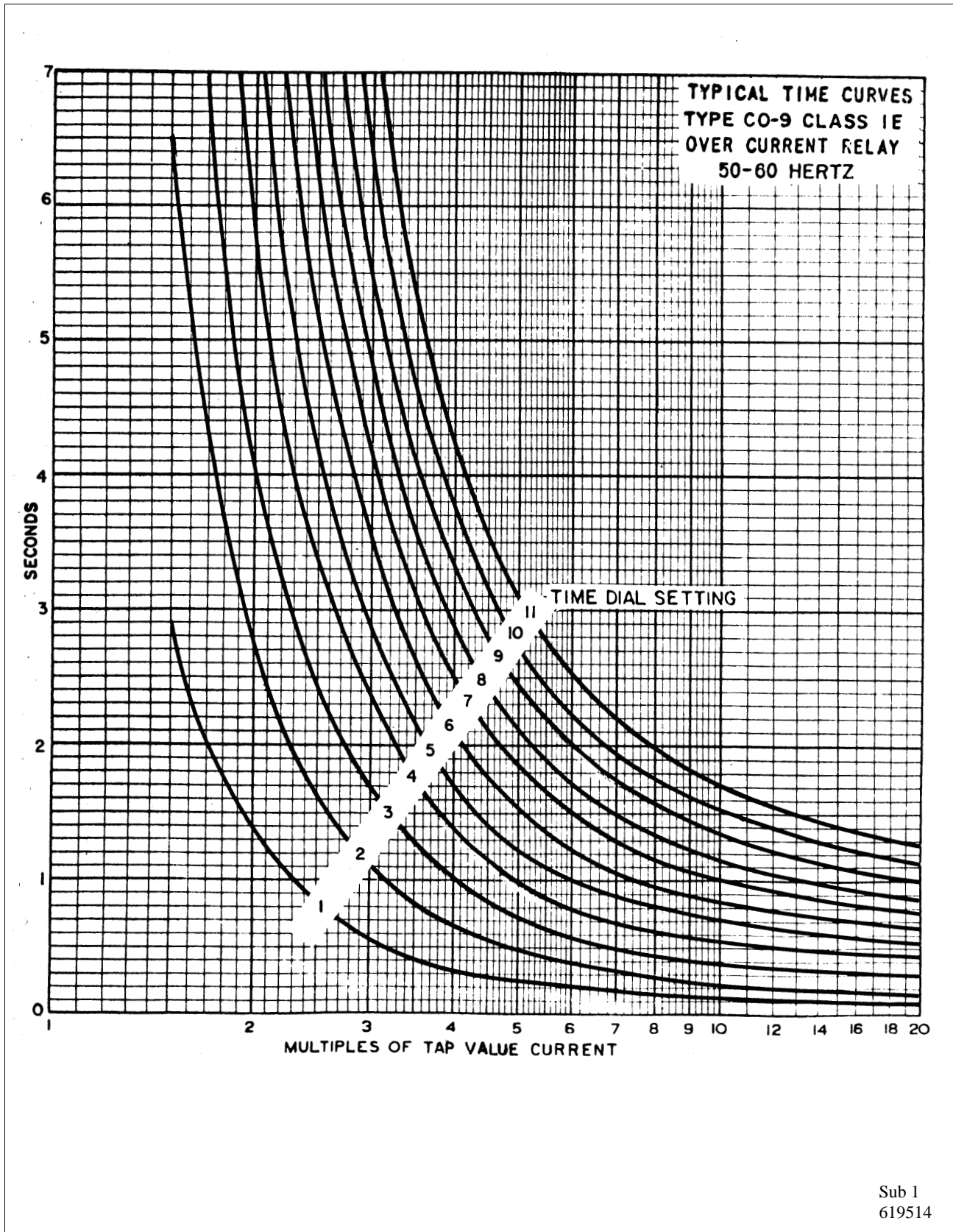

Sub 1
619514

Figure 14: Typical Time Curve of the Type CO-9 Relay

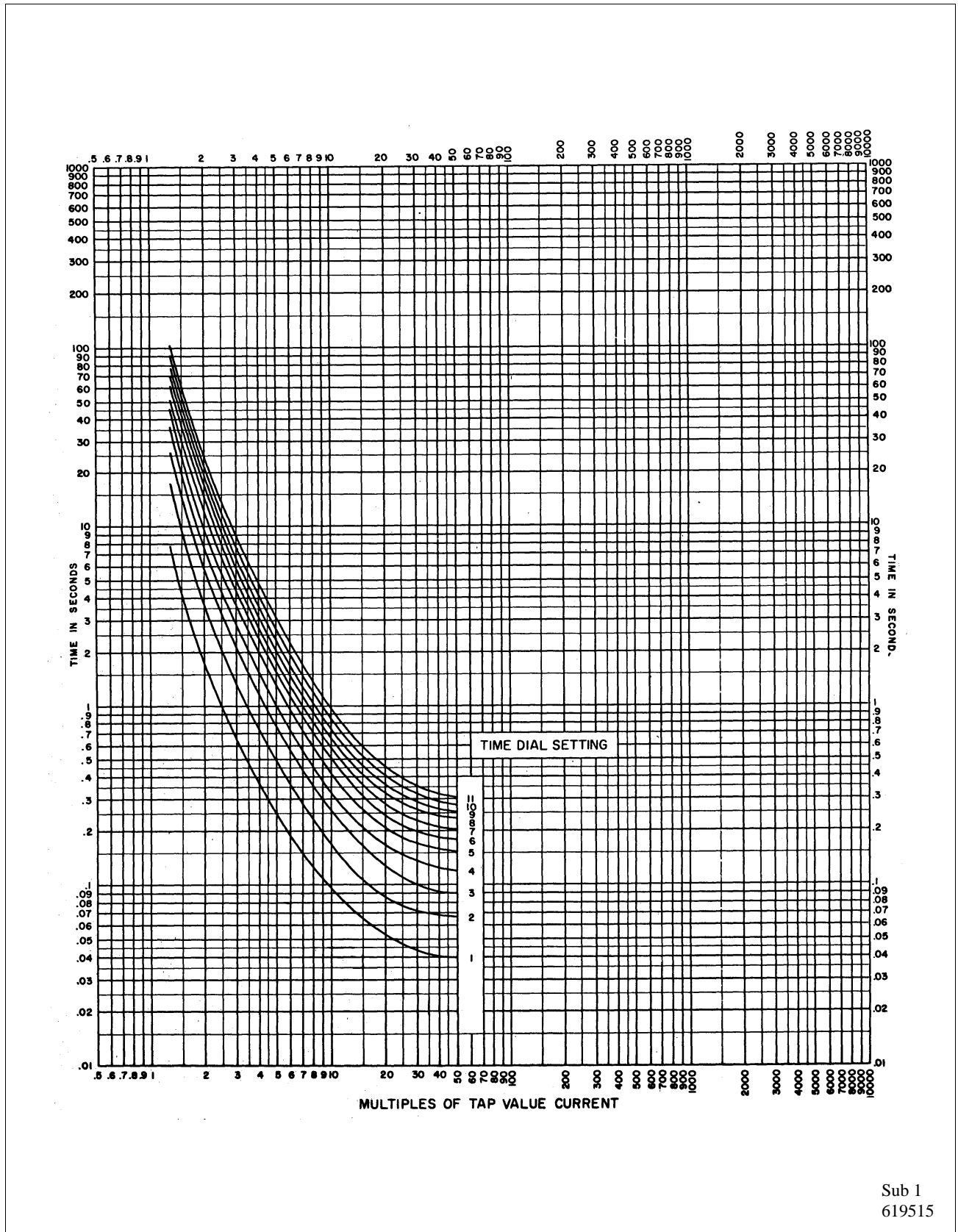

Figure 15: Typical Time Curve of the Type CO-11 Relay

Sub 1
619515

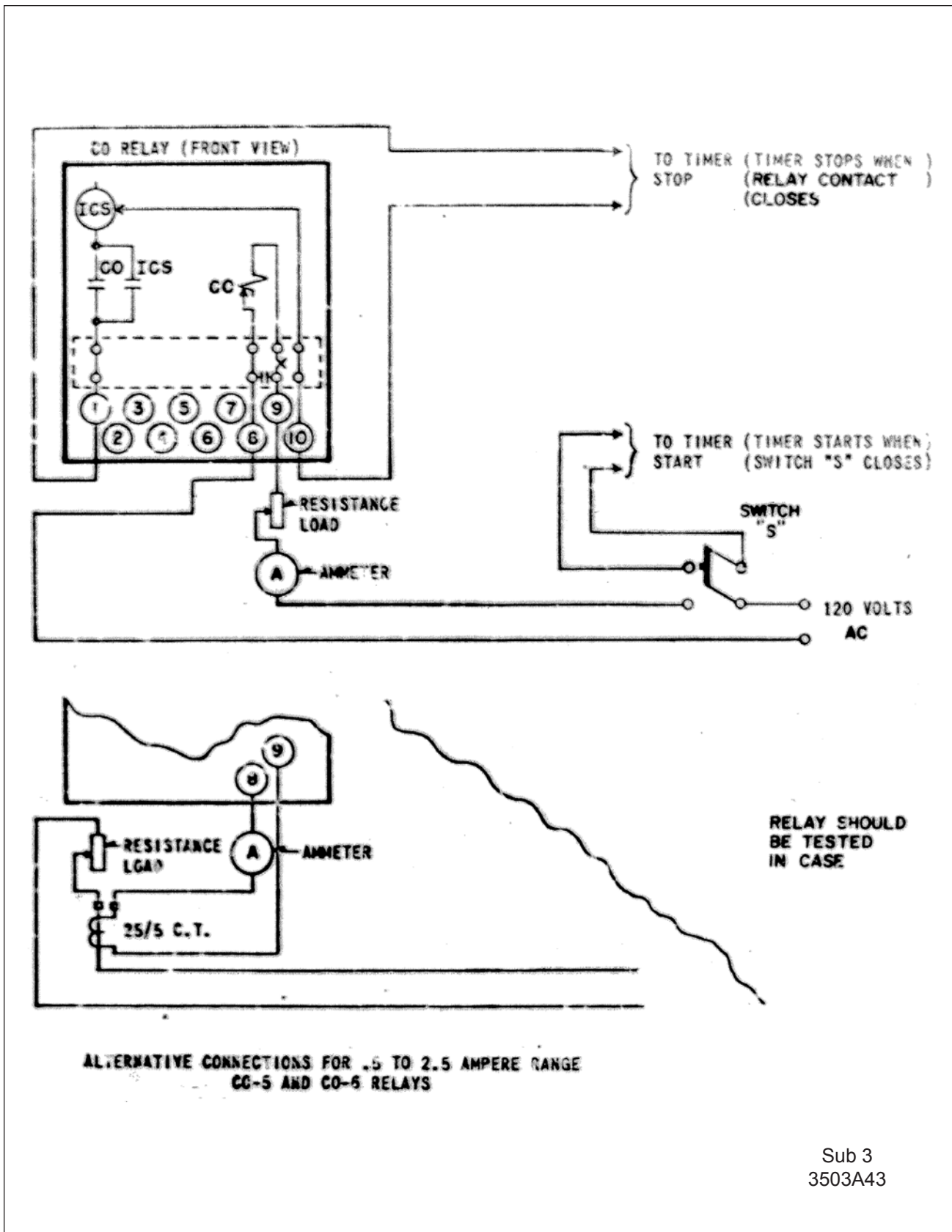

Figure 16 - Diagram of Test Connections for the Type CO Relay

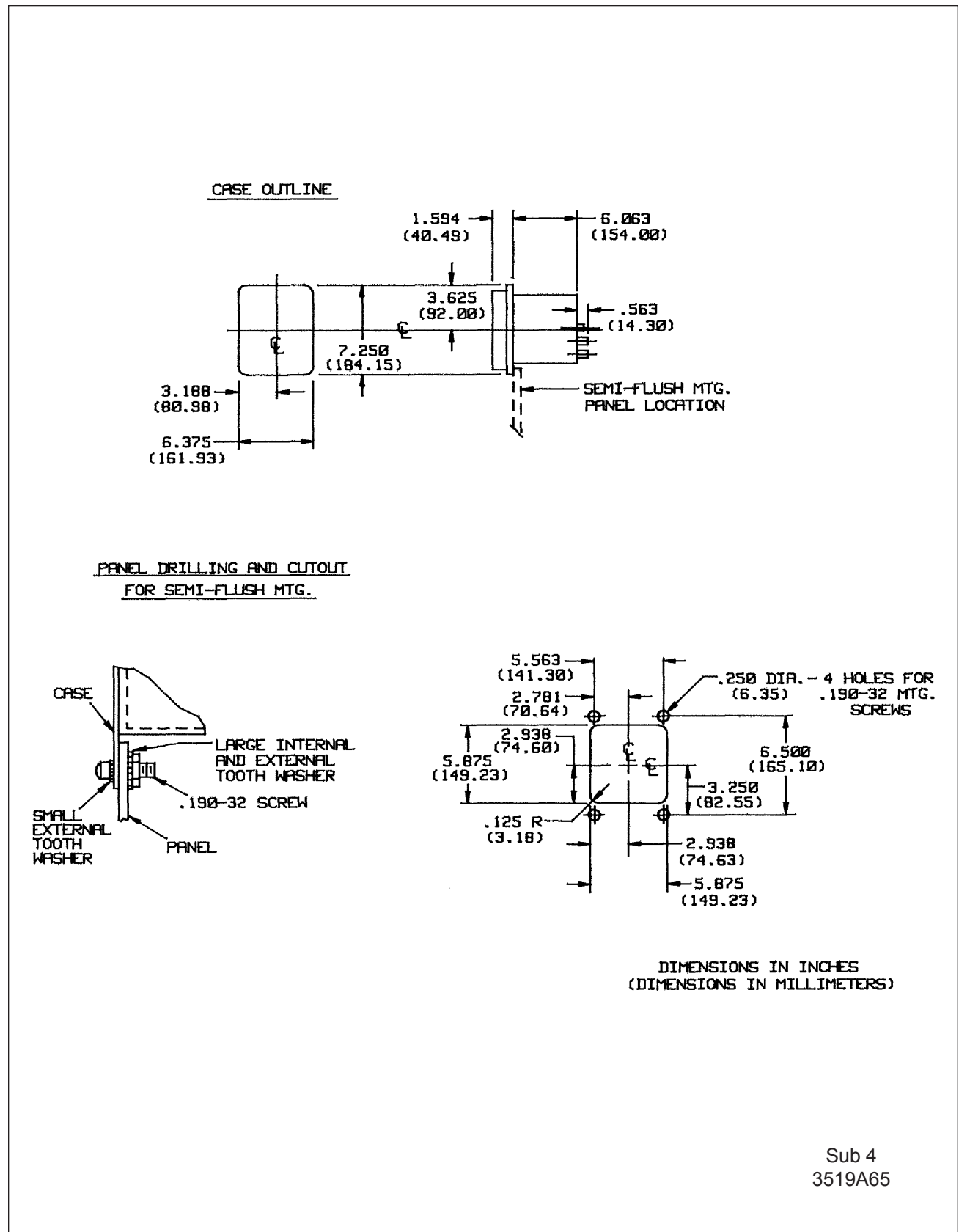

Figure 17 - Outline & Drilling Plan for the Type CO Relay in Type FT-11 Case - Class 1E

This Page Reserved for Notes

This Page Reserved for Notes



ABB Inc.

4300 Coral Ridge Drive
Coral Springs, Florida 33065

Telephone: +1 954-752-6700

Fax: +1 954-345-5329

www.abb.com/substation_automation

IL 41-100.1 - Revision C