

Release Notes

RobotStudio

6.08.01

Revision:-

The information in this manual is subject to change without notice and should not be construed as a commitment by ABB. ABB assumes no responsibility for any errors that may appear in this manual.

Except as may be expressly stated anywhere in this manual, nothing herein shall be construed as any kind of guarantee or warranty by ABB for losses, damages to persons or property, fitness for a specific purpose or the like.

In no event shall ABB be liable for incidental or consequential damages arising from use of this manual and products described herein.

This manual and parts thereof must not be reproduced or copied without ABB's written permission.

Additional copies of this manual may be obtained from ABB.

The original language for this publication is English. Any other languages that are supplied have been translated from English.

© Copyright 2008 - 2019 ABB All rights reserved.
ABB AB
Robotics Products
SE-721 68 Västerås
Sweden

Table of Contents

1 Release Information	5
1.1 General	5
1.2 System recommendation	5
1.3 Simulation Models	7
2 What's new in RobotStudio 6.08	9
2.1 Improved corner zone behavior	9
2.2 Collision avoidance	11
2.3 MovePnP: New motion instruction for Pick-and-Place	12
2.4 YuMi Smart Gripper Collision Avoidance Configuration	13
2.5 New Smart Components: MarkupControl and StringFormatter	14
2.6 Add Controller from Device List	14
2.7 IRB 5500 for Paint Rail	15
3 Late Breaking Information	16
4 Corrections	17
4.1 Corrections made in 6.08.01	17
4.2 Corrections made in 6.08	17
5 Known Limitations	20
5.1 Visual SafeMove	20
5.2 Online	20
5.2.1 Online – Paint	20
5.2.2 Online – Integrated Vision	21
5.3 Offline	23
5.3.1 Conveyor Tracking	25
5.3.2 Station Viewer	26
5.3.3 MultiMove	26
5.3.4 External Axis	27
5.3.5 Network Drives and UNC Paths	27
5.3.6 RAPID	28
5.3.7 Paint	28

Table of Contents

5.3.8 Graphics and Geometry	29
5.4 ScreenMaker Limitations	29
6 RobotWare Compatibility	31
6.1 General	31
6.2 RobotWare 5.05 and 5.06 Compatibility	31
6.3 RobotWare 5.07 Compatibility	31
6.4 RobotWare 5.08 Compatibility	31
6.5 RobotWare 5.10 Compatibility	31
6.6 RobotWare 5.11 Compatibility	31
6.7 RobotWare 5.12 Compatibility	32
6.8 RobotWare 5.13 Compatibility	32
6.9 RobotWare 5.15 Compatibility	33
6.10 RobotWare 6 Compatibility	33
6.11 General Compatibility Limitations	33
6.12 ScreenMaker Compatibility	33
6.13 Support for future RobotWare versions	34

1 Release Information

1.1 General

Release Name

The release name is RobotStudio 6.08.01 and the build number is 6.08.8307.1040. This release is a quality release that does not contain any new features but only bug corrections, see section [4.1 Corrections made in 6.08.01](#).

Release Date

The release date is February 18th, 2019.

Demo stations

The following demo stations are included in this version.

- Demo AW Station
- Demo Solar Simulation
- Demo Exhaust Pipe
- Demo FlexLoader

They are stored in the Pack & Go format (.rspag) and can be opened with the command Unpack & Work on the Share section of the RobotStudio menu.

ScreenMaker Demo Station and Project

There is a demo station and associated ScreenMaker project available.

- SCM_ExampleProject (*ScreenMaker Project*)
- SCM_ExampleStation (*RobotStudio station*)

These files are found in the 'Addins/ScreenMaker/Samples' folder under the RobotStudio installation folder.

Tutorials

Tutorials are available at the RobotStudio product pages at <http://www.abb.com/roboticssoftware>

Documentation

User documentation for RobotStudio is available from the *Help* button () in the upper-right corner of RobotStudio.

The complete documentation in PDF for RobotWare including RobotStudio is available from the Help menu in RobotStudio for Premium users. Internet connection is required.

1.2 System recommendation

Recommended Software

Operating System	
Microsoft Windows 7 SP1	32-bit edition
Microsoft Windows 7 SP1 (recommended)	64-bit edition
Microsoft Windows 10 Anniversary update or later (recommended)	64-bit edition

It is recommended to run Windows Update to get the latest updates to Windows prior to installing and running RobotStudio. This applies to any of the operating systems above.



Note

The Windows Firewall will try to block features necessary to run RobotStudio. Make sure to unblock these features when asked (Industrial Robot Discovery Server, RobotStudio StudioAppFramework module, Virtual RobotController (all published by ABB)). The blocking state of a certain program can be viewed and changed at *Start/Control Panel/Windows Security Center/Windows Firewall*. Read more on <http://www.microsoft.com>.

Recommended Hardware

Item	Requirement
CPU	2.0 GHz or faster processor, multiple cores recommended
Memory	3 GB if running Windows 32-bit 8 GB or more if running Windows 64-bit (recommended)
Disk	10+ GB free space, solid state drive (SSD)
Graphics card ¹	High-performance, DirectX 11 compatible, gaming graphics card from any of the leading vendors. For the Advanced lightning mode Direct3D feature level 10_1 or higher is required.
Screen resolution	1920 x 1080 pixels or higher is recommended
DPI	Normal size (100% / 96 dpi) up to Large size (150% / 144 dpi) Only Normal size supported for Integrated Vision.
Mouse	Three-button mouse
3D Mouse [optional]	Any 3D mouse from 3DConnexion, see http://www.3dconnexion.com .
Virtual Reality Headset	Oculus Rift, HTC Vive or any Windows Mixed Reality Headset. Note that special PC hardware requirements apply when using RobotStudio with VR, see https://www.oculus.com/oculus-ready-pcs/ , https://www.vive.com/us/ready/ , or https://www.microsoft.com/en-us/windows/windows-mixed-reality-devices , respectively.

¹ A note on graphics cards and PC hardware. RobotStudio will not benefit from the additional features of so-called 'Professional' or 'Workstation' graphics cards. The price level of these are at a much higher range than gaming graphics cards with comparable performance. High-end gaming PCs are very suitable for offline programming with RobotStudio. Such a PC will provide good performance for a limited budget.

1.3 Simulation Models

Robot Libraries

IRB Variant	IRB Variant	IRB Variant
120 3kg/0.58m	4400S 30kg	6700 200 kg/2.8m SW
120T 3kg/0.58m	4450S 30kg	6700 205 kg/2.8m MH3
1200 5kg/0.9m BTM (. /FGL/*FPL)	4600 20kg/2.5m	6700 205 kg/2.8m
1200 5kg/0.9m STD (. /FGL/*FPL)	4600 20kg/2.5m Type C	6700 140 kg/2.85m MH
1200 7kg/0.7m BTM (. /FGL/*FPL)	4600 45kg/2.05m Type C	6700 140 kg/2.85m SW
1200 7kg/0.7m STD (. /FGL/*FPL)	4600 60kg/2.05m	6700 155 kg/2.85m MH3
140 5kg/0.8m Type A/B	4600 60kg/2.05m Type C	6700 155 kg/2.85m
140 5kg/0.8m Type C	460	6700 220 kg/2.65m MH
140 6kg/0.8m Type C	4600 40kg/2.55m	6700 220 kg/2.65m SW
140T 5kg/0.8m Type C	4600 40kg/2.55m Type C	6700 235 kg/2.65m MH3
1400 Type A/B	4600 45kg/2.05m	6700 235 kg/2.65m
1400H Type A/B	6400R 200kg/2.5m	6700 175 kg/2.6m MH
1410	6400R 200kg/2.8m	6700 175 kg/2.6m SW
1520ID	6400R 120kg/2.5m	6700 200 kg/2.6m MH3
1600 5kg/1.2m	6400R 150kg/2.8m	6700 200 kg/2.6m
1600 5kg/1.2m Type A	6400R 150kg/2.8m	6700 220kg/3.0m MH
1600 5kg/1.45m	6400R 100kg/3.0m	6700 220kg/3.0m SW
1600 5kg/1.45m Type A	640	6700 245kg/3.0m MH3
1600 6kg/1.2m	660 180kg/3.15m	6700 245kg/3.0m
1600 6kg/1.45m	660 250kg/3.15m	6700 270kg/2.7m MH
1600 7kg/1.2m	6600 175kg/2.55m	6700 270kg/2.7m SW
1600 7kg/1.2m Type A	6600 175kg/2.80m	6700 300kg/2.7m MH3
1600 7kg/1.45m	6600 225kg/2.55m	6700 300kg/2.7m
1600 7kg/1.45m Type A	6600ID 185kg/2.55m	6700 Inv 210kg/2.9m MH6
1600 8kg/1.2m	6620 150kg/2.2m	6700 Inv 210kg/2.9m SW6
1600 8kg/1.45m	6620LX-150/1.9m	6700 Inv 245kg/2.9m
1600 10kg/1.2m	6640 130kg/3.2m	6700 Inv 245kg/2.9m MH3
1600 10kg/1.45m	6640 180kg/2.55m	6700 Inv 270kg/2.6m MH6
1600ID 4kg/1.5m	6640 185kg/2.8m	6700 Inv 270kg/2.6m SW6
1660ID 4kg/1.55m	6640 205kg/2.75m	6700 Inv 300kg/2.6m
1660ID 6kg/1.55m	6640 235kg/2.55m	6700 Inv 300kg/2.6m MH3
2400 10kg	6640ID 170kg/2.75m	7600 150kg/3.5m
2400 16kg	6640ID 200kg/2.55m	7600 325kg/3.1m
2400L	6640 150kg/2.55m DP6	7600 340kg/2.8m
2600 12kg/1.65m	6640 165kg/2.8m DP6	7600 400kg/2.55m
2600 20kg/1.65m	6640 185kg/2.75m DP6	7600 500kg/2.55m
2600 12kg/1.85m	6640 200kg/2.55m DP6	7600 500kg/2.3m
2600ID 8kg/2.0m	6650 125kg/3.2m	7600 150kg/3.5m MH3
2600ID 15kg/1.85m	6650 200kg/2.75m	7600 325kg/3.1m MH3
260	6650ID 170kg/2.75m	7600 340kg/2.8m MH3
340	6650S 125kg/3.5m	7600 400kg/2.55m MH3
360 1kg/1130 Std No axis 4	6650S 200kg/3.0m	7600 500kg/2.55m MH3
360 1kg/1130 Wash-down No axis 4	6650S 90kg/3.9m	7600 390kg/3.1m MH6
360 1kg/1130 Standard	6650S 100kg/3.5m MH6	7600 320kg/2.8m MH6
360 1kg/1130 Wash-down	6650S 190kg/3.0m MH6	7600 390kg/2.55m MH6
360 1kg/1130 Stainless	6650S 100kg/3.5m SW6	7600 390kg/3.1m SW6
360 1kg/800 Std No axis 4	6650S 190kg/3.0m SW6	7600 320kg/2.8m SW6
360 1kg/800 Wash-down No axis 4	6650S 125kg/3.5m MH3	7600 390kg/2.55m SW6
360 1kg/800 Std	6650S 200kg/3.0m MH3	760
360 1kg/800Wash-down	6650S 90kg/3.9m MH3	8700 475kg/4.2m MH6
360 3kg/1130 Std No axis 4	6600 100kg/3.35m	8700 475kg/4.2m SW6
360 3kg/1130 Wash-down No axis 4	6660 130kg/3.1m	8700 550kg/4.2m MH3
360 3kg/1130 Standard	6660 205kg/1.9m	8700 550kg/4.2m
360 3kg/1130 Wash-down	6700 145 kg/3.2m MH	8700 630kg/3.5m MH6
360 3kg/1130 Stainless	6700 145 kg/3.2m SW	8700 630kg/3.5m SW6
360 1kg/1600 Standard	6700 150 kg/3.2m MH3	8700 800kg/3.5m MH3
360 6kg/1600 Standard	6700 150 kg/3.2m	8700 800kg/3.5m
360 8kg/1130 Standard	6700 155 kg/3.05m MH	910SC 3kg/0.45m
4400 45kg	6700 155 kg/3.05m SW	910SC 3kg/0.55m
4400 60kg	6700 175 kg/3.05m MH3	910SC 3kg/0.65m
4400L 10kg	6700 175 kg/3.05m	**940
4400L 30kg	6700 200 kg/2.8m MH	14000

** requires the StandAlone Controller mediapool that is available for download from Add-Ins tab / RobotApps / RobotWare Add-Ins



Note

All simulation models in the table are installed with RobotStudio, but only the robots in the current product range are displayed in the ABB Library gallery. To import any other robot you need to browse to the file on disk.

Robot Libraries Paint

Variant
52 short vertical arm
52 std vertical arm
540-12 std arm
580-12 std arm
580-12 short arm
5300-12 left
5300-12 right
5320-1500
5320-2000
5350/01 Type Left
5350/01 Type Right
5350/02 Type Left Side Left
5350/02 Type Left Side Right
5350/02 Type Right Side Left
5350/02 Type Right Side Right
5400-12 std arm
5400-13 std arm
5400-14 std arm
5400-22 process arm
5400-23 process arm
5400-24 process arm
5400-12 std arm axis 2 +60 deg
5400-13 std arm axis 2 +60 deg
5400-14 std arm axis 2 +60 deg
5500 35A b_00 / b_80
5500 35B b_00 / b_80
5500 ProArm 35A b_00 / b_80
5500 ProArm 35B b_00 / b_80
5510

Track Libraries

RobotStudio is distributed with the following track types that are available in the Track folder of the ABB Library.

Track family	Length
IRBT2005	2 m to 21 m
IRBT4003	1.7 m to 10.7 m
IRBT4004	1.9 m to 19.9 m
IRBT6003	1.7 m to 10.7 m
IRBT6004	1.7 m to 19.7 m
IRBT7003	1.7 m to 10.7 m
IRBT7004	1.7 m to 19.7 m
RTT_Bobin	1.7 m to 11.7 m
RTT_Marathon	1.7 m to 11.7 m
Paint Rails left and right versions	2 m to 20 m
IRB5350 Rail left and right versions	3 m to 10 m
Elevated Rail left and right versions	3 m to 10 m

2 What's new in RobotStudio 6.08

Overview

This section describes the new features of RobotStudio 6.08.

2.1 Improved corner zone behavior

Overview

The corner zone behavior of the IRC5 robot has been improved to make better use of the programmed zonedata in RAPID. Two improvements are made. The first one is related to the symmetry of the zones (configuration parameter *Allow asymmetric zones*), and the second one to the zone utilization at fine points (configuration parameter *Relative zone size with finepoint*). The benefit is that cycle time may decrease and wear may be reduced due to smoother motion.

The default behavior is unchanged, but the new feature can be enabled by editing the configuration parameters.

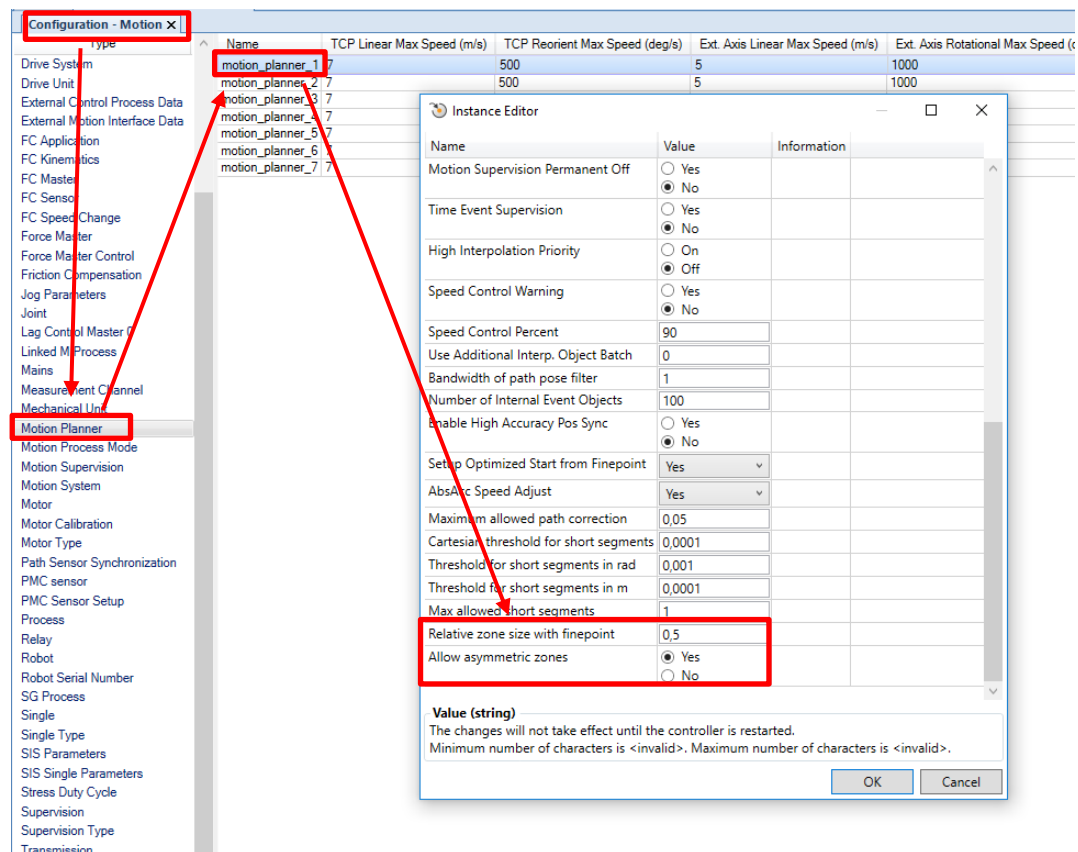

Figure 1. The new configuration parameters displayed in the Configuration Editor

New way of visualizing programmed and actual zones (zonedata)

To allow visualization of asymmetrical zones, the programmed zones will be shown as plane circles. Any zone reductions imposed by the controller will be displayed as chords. This applies also to the symmetric zones. The reason is that the asymmetric zones cannot be represented by spheres.

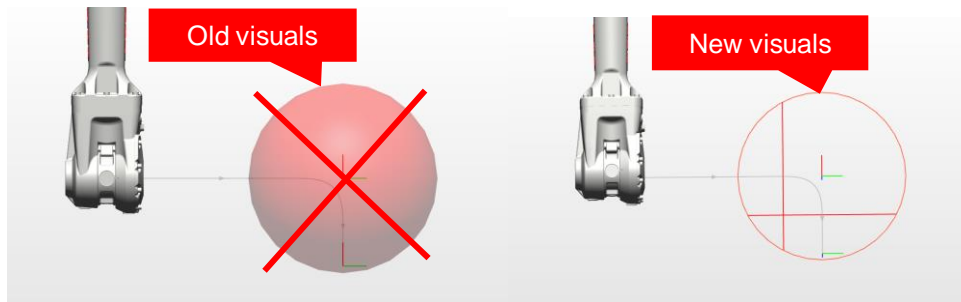

Figure 2. The left picture shows the old way of visualizing zonedata (spheres) and the right picture shows the new way (plane circles for the programmed zones and chords for the actual zones).

Asymmetrical zones

The first configuration parameter controls whether zones can be asymmetric. This means that a corner zone can have different lengths of the inbound path and the outbound path.

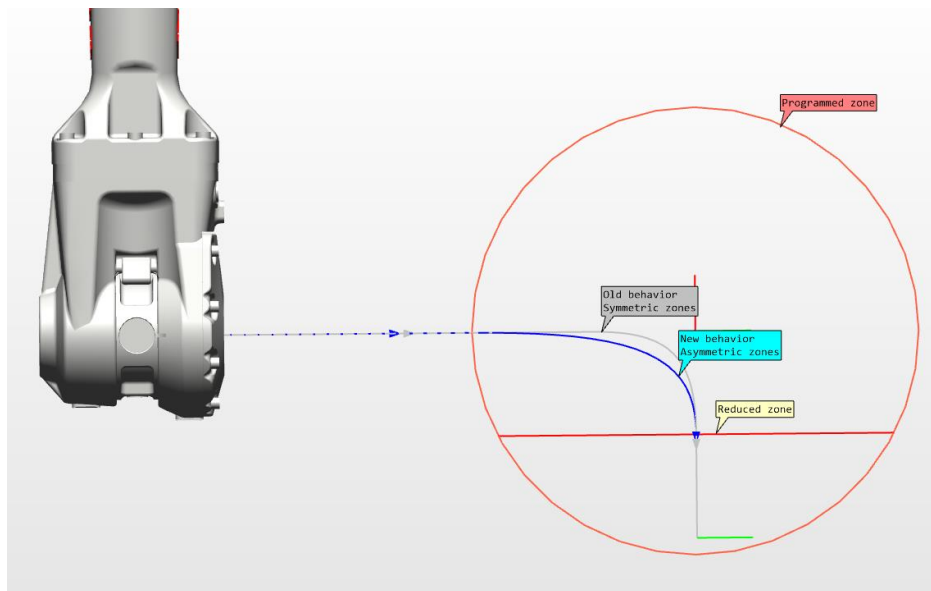

Figure 3. The blue path shows the path when asymmetric zones are allowed, and the grey one shows the default behavior. The circle indicates the programmed zone and the chord shows the actual, reduced zone. Note that only the outbound path is affected by the closest robotarget in the example. The inbound path is not restricted but can use the full zone size for the corner point.

Increased zone size

The second parameter controls the zone extension in relation to fine points. The new parameter allows the zone to be extended (almost) all the way to the fine point.

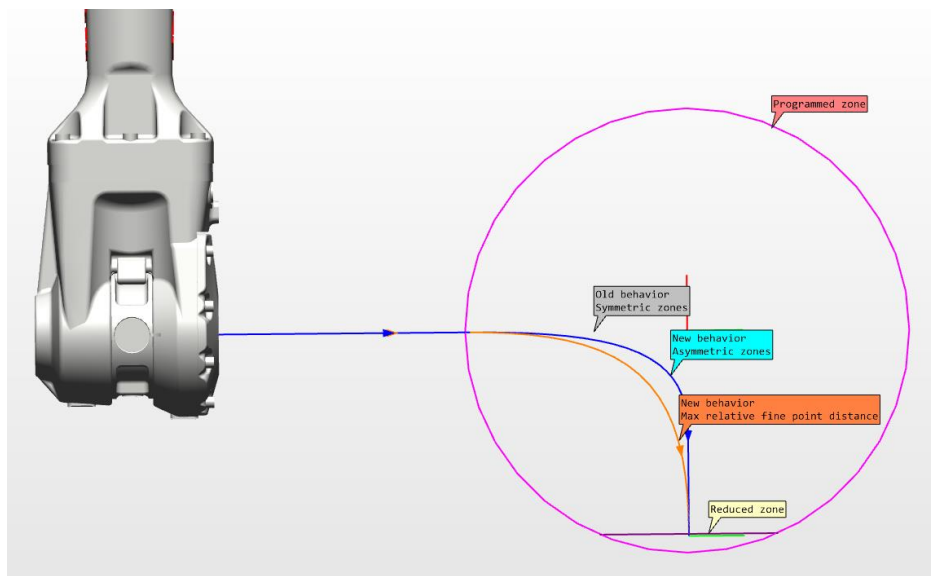

Figure 4. Similar to Figure 3, but with the difference that the zone is allowed to be stretched all the way up to the fine point, see the orange path.

2.2 Collision avoidance

Feature

The feature Collision Avoidance runs in the real robot controller, predicts collisions and stops the robot before the predicted collision occurs. The robot, its equipment and surrounding geometry can be modeled by simplified graphics. The robots are pre-modeled and the user can configure collision geometries for the other equipment using RobotStudio. In 6.08, all bending backwards robots are supported. (120, 140, 1200, 1600, 1660, 1520, 2600, 4600, 6620, 6640, 6600, 6650, 6700, 6790, 7600). It requires RobotWare option "Collision Detection". The current state of the collision geometries as well as any predicted collisions can be viewed in the Online Monitor. The feature is available in RobotStudio Basic, i.e. the free version. For importing geometries in CAD-formats, the Premium version is required (for SAT) and the corresponding CAD-converter option (for other formats). Polygon (triangle) formats such as VRML, STL, or RSGFX does not require any license but can be imported into the Basic version.

Benefit

The collision avoidance feature is helpful in protecting the robot and the equipment from being damaged due to collisions. It is useful when the robot program is non-deterministic in which case targets may be generated from vision sensors in run-time. Also it is useful for preventing collisions between robots in MultiMove system or on dual carriage track motion.

Note that Collision Avoidance is not a safety feature. It is for protecting equipment, not for protecting people. SafeMove2 shall be used for functional safety.

Robot stops due to predicted collision

The example illustrated with the two pictures below shows a collision, predicted and prevented by the robot controller.

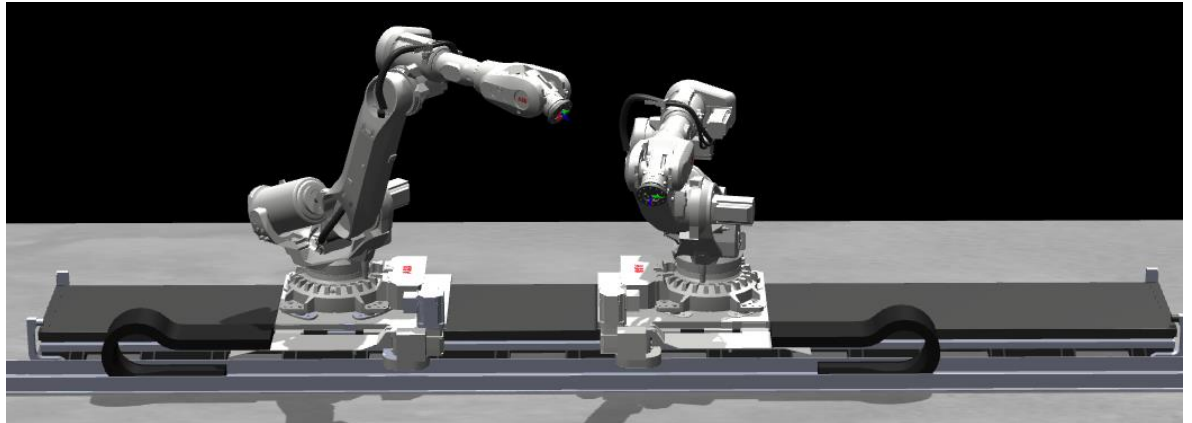

Figure 5. The picture shows two robots on a dual carriage track motion that are on the way to run into one another.

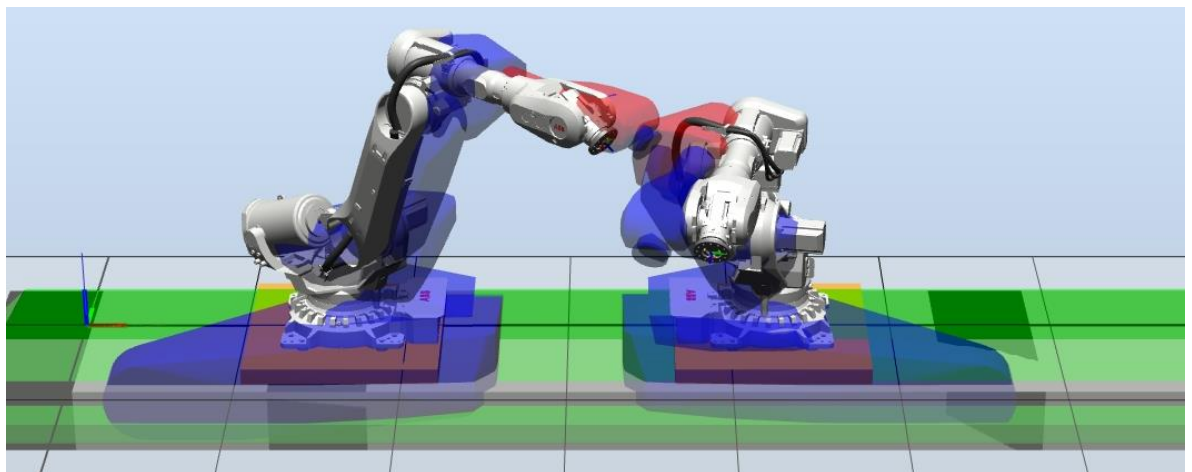

Figure 6. The same robots as in Figure 5 viewed in Online Monitor. It shows the collision predicted by the controller. The controller will stop the robot to prevent the collision from occurring.

2.3 MovePnP: New motion instruction for Pick-and-Place

Overview

There is a new motion instruction for the SCARA robot (IRB 910SC). The goal of the new instruction was to get the lowest cycle time for pick-and-place operations. The new instruction (MovePnP) is programmed with one robtarget and a number of parameters for controlling the shape and the height of the motion.

The motion is an arc which curvature attempts to minimize the cycle time. It is neither MoveJ, nor MoveL. It might look extremely similar to MoveJ, and for some others it might look extremely similar to, MoveL, but indeed is none of them. The motion in the horizontal plane cannot be specified. MovePnP will never produce an arc wider than MoveJ.

It can be programmed with RobotStudio. The corresponding instruction template must be added manually in RobotStudio 6.08 using the Instruction Template Manager.

The instruction may give a cycle time improvement of 8-9% for MovePnP compared to using MoveJ, or MoveL, see Figures 7 and 8. Note that the performance improvement may vary depending on the situation and may be higher or lower in other cases.

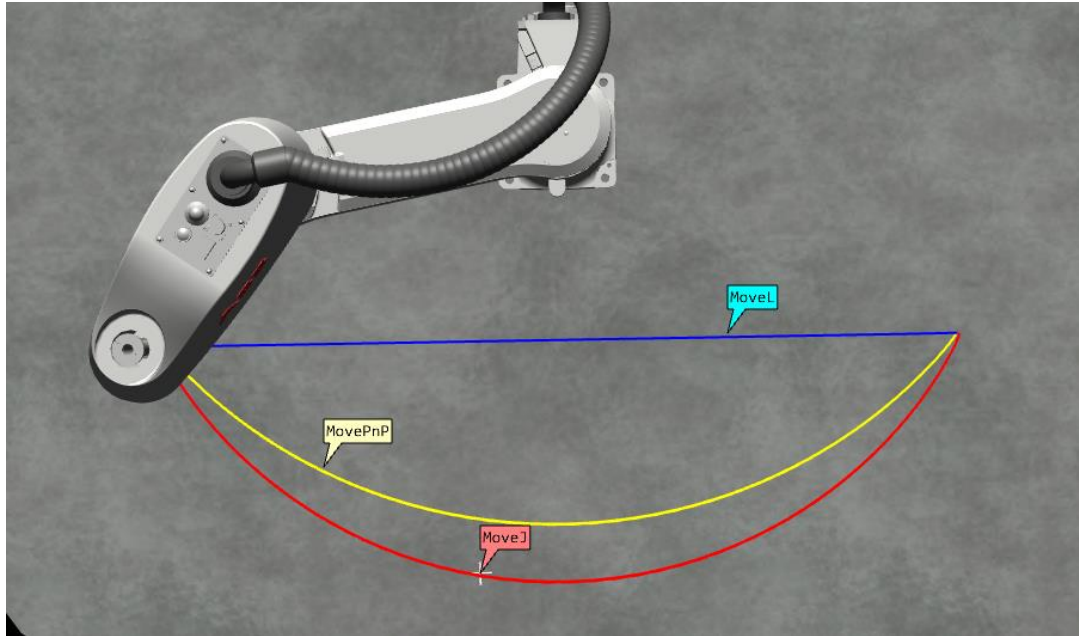

Figure 7. The picture shows an example of the MovePnP from the top view. The yellow path shows the trace of the MovePnP and the blue and red traces are examples of the corresponding motion programmed with MoveL and MoveJ, respectively.

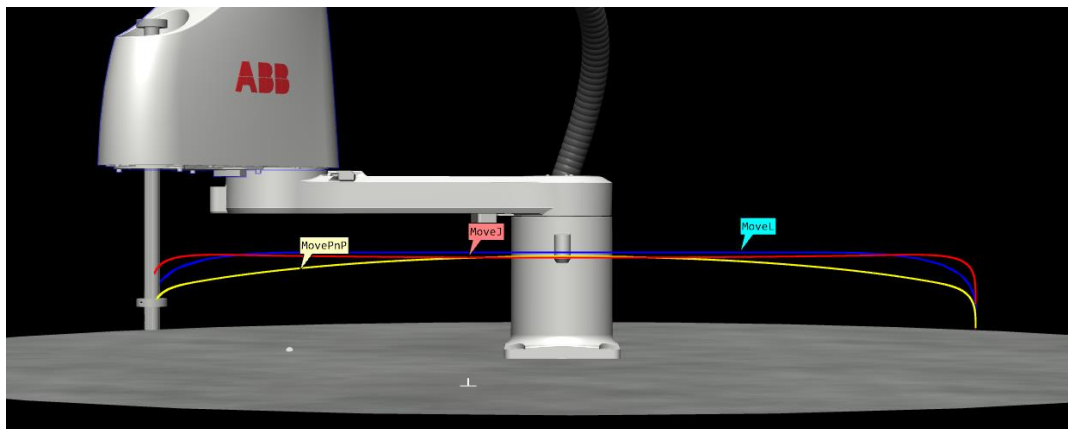
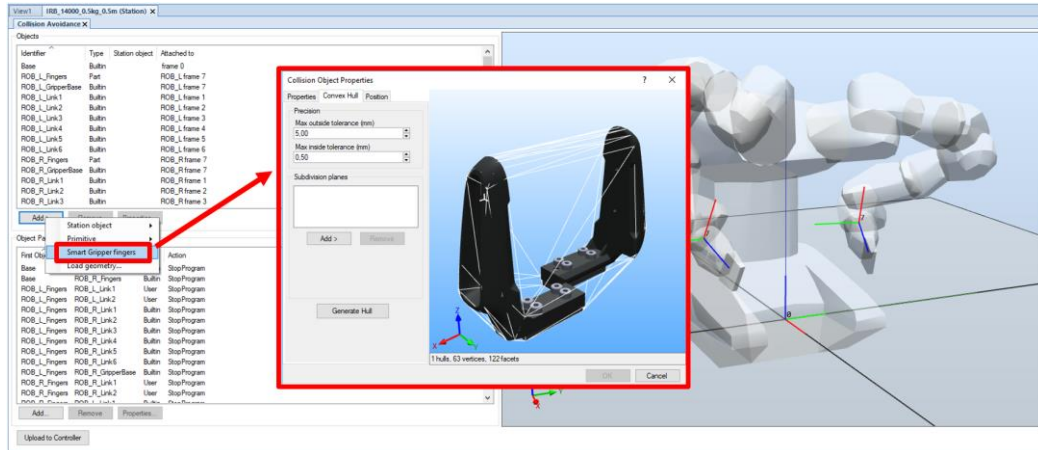

Figure 8. Front view of the MovePnP (yellow) together with corresponding MoveL (blue) and MoveJ (red).

2.4 YuMi Smart Gripper Collision Avoidance Configuration

Overview

The Collision Avoidance configuration tool for the YuMi smart gripper has been integrated into the general Collision Avoidance configuration tool.



2.5 New Smart Components: MarkupControl and StringFormatter

Overview

Two new smart components are added in 6.08. The first one is called MarkupControl and can control the properties of a graphical markup. Markup content can be dynamically changed e.g. during a simulation. The second one is the StringFormatter that can be used to format a text string, e.g. the text displayed in the MarkupControl.

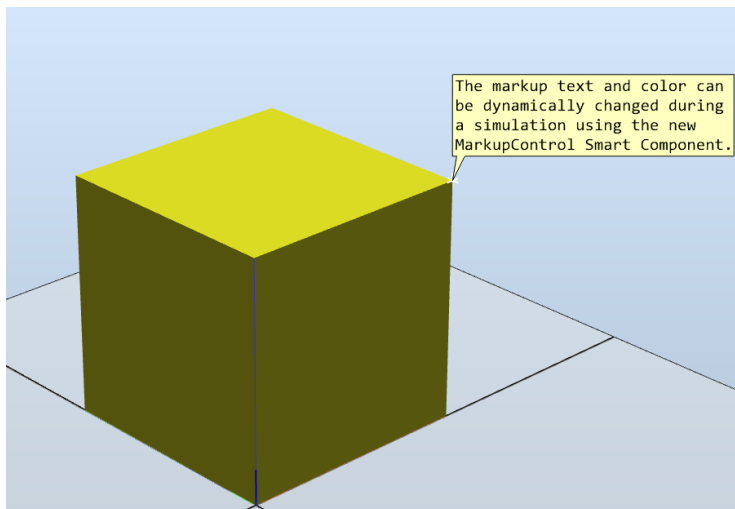

2.6 Add Controller from Device List

Moved from Premium to Basic

The function "Add controller from Device List" is not new but reuses the Device List from Jobs to allow connection to robots controllers not found by the usual Add Controller function. The function looks up the robot controller network address in the device list and connects to it.

The function "Add controller from Device List" has been moved from Premium to Basic. The reason is that the function is needed by end-customers with line-PCs connected to robots that are on different subnets. These line-PCs do not have RobotStudio Premium in general.

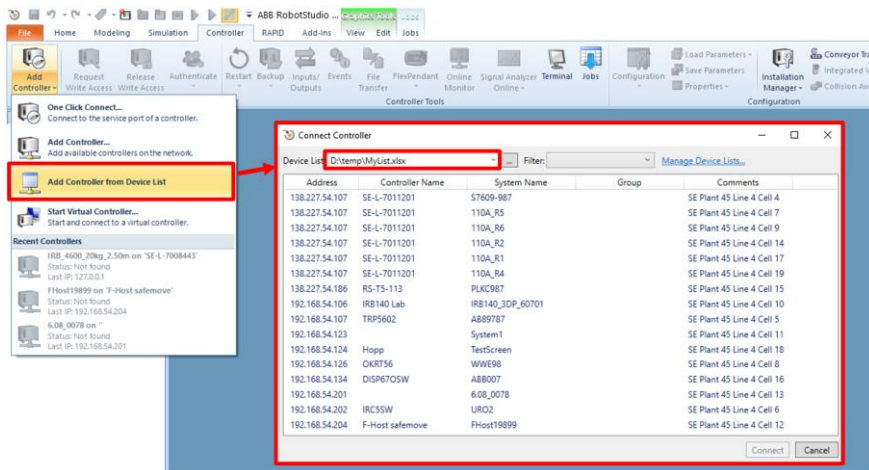

2.7 IRB 5500 for Paint Rail

The IRB 5500 with extended foot for mounting on the Paint Rail.

The IRB 5500 can be mounted on the Paint Rail if the extended foot is used. In RobotStudio 6.08 we have updated the Paint Rail with a version that has the corresponding carriage.

To start a virtual robot controller, import the paint rail, the robot, mount the robot on the rail and select **Home -> Robot System -> From Layout...**

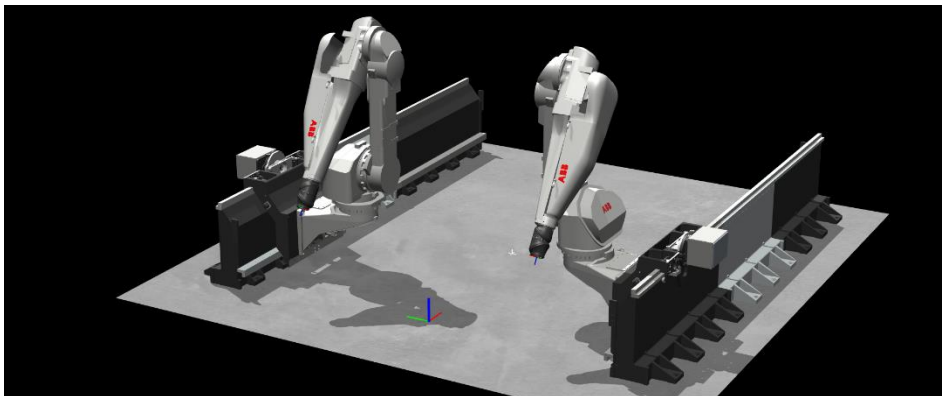

3 Late Breaking Information

Overview

This section describes changes and additions done after the Operating Manual was finalized.

*Updates to CAD format versions

RobotStudio 6.08.01 includes an updated CAD converter that supports the latest versions (ACIS 2019). The table below lists all formats and versions supported by RobotStudio for completeness even though not all of them have been updated for 6.08.01.

Format	File extensions	Option required
3DStudio	.3ds	-
ACIS, reads versions R1 - 2019 1.0, writes versions R18 - 2019 1.0	.sat, .sab, .asat, .asab	-
CATIA V4, reads versions 4.1.9 to 4.2.4*	.model, .exp, .session	CATIA V4
CATIA V5/V6, reads versions V5R8 – V5/V6R2018 writes V5R15 – V5/V6R2018*	.CATPart, .CATProduct, .CGR, .3DXML	CATIA V5
COLLADA 1.4.1	.dae	-
DirectX writes 2.0	.x	-
DXF/DWG, reads versions 2.5 - 2019*	.dxf, .dwg	AutoCAD
FBX writes version 7.5	.fbx	-
IGES, reads up to version 5.3, writes version 5.3*	.igs, .iges	IGES
Inventor, reads V6 – V2019*	.ipt, .iam	Inventor
JT, reads versions 8.x, 9.x and 10 and 10,2*	.jt	JT
LDraw, reads version 1.0.2	.ldr, .ldraw, .mpd	-
NX, reads versions NX 11 – NX 12.0.0*	.prt	NX
OBJ	.obj	-
Parasolid, reads versions 9.0.* – 31.0.x.*	.x_t, .xmt_txt, .x_b, .xmt_bin	Parasolid
Pro/E / Creo, reads versions 16 – Creo 5.0*	.prt, .prt.*, .asm, .asm.*	Pro/ENGINEER
Solid Edge, reads versions V18 – ST11*	.par, .asm, .psm	SolidEdge
SolidWorks, reads versions 2003 – 2019 *	.sldprt, .sldasm	SolidWorks
STEP, reads versions AP203, AP214, AP242, writes version AP214 *	stp, step, p21	STEP
STL	stl	-
VDA-FS, reads 1.0 and 2.0, writes 2.0*	vda, vdafs	VDA-FS
VRML, reads VRML2 (VRML1 not supported)	wrl, vrml, vrml2	-

* Supported only in the 64-bit version of RobotStudio.

4 Corrections

Overview

This section lists the corrections made.

4.1 Corrections made in 6.08.01

PDDs

ID	Title
10556	Parts with physics properties incorrectly copied when copied using the Source Smart Component. When copying a part using the Source smart component, the part became incorrectly positioned if it had its Physics properties set to Dynamic.
10578	Failure to set program pointer to in RAPID to line with comment RobotStudio threw an exception when setting the program pointer in the RAPID Editor to a line with a comment, i.e. a line beginning with an exclamation mark ("!").
10598	Failure to create target for specific station with several tasks and MultiMove.
10631	The work envelope showing the reachability of the IRB 6620LX in 2D and 3D was not correct.
10699	Jobs from Command Prompt fails if credentials are supplied Running a Job using the RunJob.exe from the command prompt or through a script failed if credentials were supplied
10851	When loading a SafeMove Pro configuration including a track motion, the 'Max speed manual mode' for the track motion was not taken from the safety configuration, but read from the motion configuration
10892	StationViewer Unpacker has stopped working
10944	Import of Inventor 2019 CAD files not possible in RS 6.08
11022	Layout browser not always updated due to problem with Undo handling.
11111	Error when trying to edit connections between Logical Gate Smart Components in Smart Componentn Design view.
11117	An error appeared after several minutes after simulation due to incorrect collision geometry generation
11132	RobotStudio fails when restoring backup with non-integer value for CountsPerMeter for conveyor tracking
11165	Error when enabling physics for certain parts due to problem with generation of collision geometries.

4.2 Corrections made in 6.08

PDDs

ID	Title
5512	Importing AutoCAD files not always working
6769	Difficult to fine tune conveyor position It was difficult to fine tune the conveyor position when working with Conveyor Tracking. As scale factor has been added to scale down the movement of the conveyor in relation to the jog slider. Note that the scale factor has no effect if a workobject is selected as reference. This will be improved in a later version of RobotStudio.
9343	Error message about insufficient Access Level for I/O signals not localized The error message that informs about insufficient Access Level for setting I/O signal values in the I/O System viewer was only displayed in English. It has now been translated to all available RobotStudio languages.
9438	Visual SafeMove: Exception when connection to controller is lost

	The error handling has been improved in Visual SafeMove to handle the case when the controller connection is lost.
9502	Visual SafeMove: The Capsule shape became invisible when start and end had been equal When configuring a shape of type Capsule, then it became invisible if the start and end points were set to coincide. It remained invisible even though the start and end points were separated. This has been fixed in 6.08.
9587	Visual SafeMove: Tool related supervision functions must not be available for non-TCP robots. In the case of SafeMove2 without a TCP robot, functions related to tool supervision are not relevant and shall not be available in the user interface of Visual SafeMove
9665	Visual SafeMove: Incorrect tool tip The mouse over tool tip for the Visual SafeMove icon sometimes incorrectly reported that the function was not supported in the 64-bit version.
9689	No Simulation Model for IRB580-13 and IRB 580-14 available The simulation models for the robot IRB 580 versions 13 and 14 was previously not available but have been added to Robotstudio.
9749	Signal Analyzer - Occasional TCP speed drop when changing workobject When monitoring the TCP signal of a real or virtual robot, the signal sometimes incorrectly indicated speed drops when changing workobject. This has been fixed in RobotWare 6.08, consequently the problem may still occur with earlier RobotWare versions .
9760	Issues with RobotStudio during simulation In certain circumstances RobotStudio faced some issues during simulation. This has been fixed.
9768	Very large modules cannot be edited in the RAPID Editor RobotStudio had problems to work with extremely large RAPID modules.
9775	Copy and paste of local robtargets with long names Copy and paste of local robtargets with long names failed but is working now.
9836	Do not add main module by default for paint systems
9848	Getting error while importing system
9863	CBS-II: External axis values in points become 9E+09 when teached in RoboStudio even if logical axis defined in MOC.
9871	Modify Position for real robot controller is possible without write access
9932	Incorrect popup window in RobotStudio Data Editor
9949	Visual SafeMove changes mm values in steps of 1000 by using the small arrows.
9950	Problem with Step import
9988	Smart Component closest objet sensor detecting objects not detectable by sensors
9990	Event log message: "Not Allowed command" with RW 5.xx based VC
10009	Wrong content in instruction pick list for certain RobotWare Add-Ins
10040	RAPID Editor: RAPID data type navgeodata not found
10079	Robot does not connect to the first object while simulating conveyor tracking
10090	No paint rail with trolley for IRB 5500_WallExt version
10168	The PC SDK log memory cache filled up.
10193	CS folder does not appear on the backup tree view under RAPID tab
10238	Visual SafeMove 1: Errors when working with arrays of tooldata
10241	Sync to RAPID fails after VC has been idle for a while
10269	Exception occurs if a backup is restored with advanced controller settings and changed password
10281	Visual SafeMove 1: Not possible to load safety configuration into a real controller
10307	Grant "Remote Restart" does not work
10320	Error while renaming jointargets

10325	Misleading user prompt generated from "change options" button RobotStudio claimed restart required even if nothing was changed.
10326	Job action "Run External Tool" do not handover data for the placeholder {SerialNumber} and {ControllerId}
10333	The value of wobj0 accidentally changed in the station The value of wobj0 was accidentally changed in a particular station. As a mitigation to prevent this from occurring again, wobj0 (and tool0) are reset to correct values when the station is loaded. An exception is thrown if trying to modify wobj0 or tool0 via the API.
10337	Duplicate entries available for selection in the I/O Mapping function of the Station Logic
10368	Wrong information in Robotstudio manual regarding "Go Offline" function. The manual incorrectly listed Go Offline a Basic version but it is Premium.
10392	No values being entered for 7th axis for the IRB 5350
10409	Viewpoints does not work in Station Viewer created with RobotStudio 6.07
10415	Cannot connect to different objects on conveyor
10451	Lack of error handling when attempting backup prevented by the System Input "Disable Backup"
10452	Minimum distance measurement is not working for selection level Surface and Body
10484	PaintApplicator Smart Component stops working after creating Pack&Go
10521	VR: The function "Robot follows" does not support external axes
10523	RobotStudio freezes when attaching robot to unconfigured external axis
10540	Smart Component Design View: Unable to set Parent in Smart Componet Design View
10541	Not possible to attach physics enabled part to robot. This is solved by temporarily making a dynamic object kinematic when it is being attached through the old/nonphysics attachment system
10563	Very large station viewer files may be corrupt
10586	Online Monitor does not show the robot with correct orientation as specified by the gravity alpha and beta parameters
10596	Incorrect type of data selected when opening multiple-action Job from file
10599	Robotstudio gives error message after closing a station RobotStudio sometimes presented an error message when being closed.
10654	Visual SafeMove: Incorrect tool tip The mouse over tool tip for the Visual SafeMove icon sometimes incorrectly reported that the function was not supported in the 64-bit version.
10671	RobotStudio SDK: Collision Detection fails for temporary graphics
10672	Visual SafeMove: Incorections in safety report If the mode was set to "SC_EmergencyStop" in stop configurations, it was written as "General" in the safety report. The Input and output signals which were part of a certain device was listed again under global signals of the report
10679	Dimension of Vacuum Fingers (Smart Gripper Library) for Yumi in the Robotstudio Library not correct

5 Known Limitations

Overview

This section describes known limitations in RobotStudio.

5.1 Visual SafeMove

Protected checksum may change when upgrading RW from 6.04.0x to 6.05 or 6.06

The protected checksum will change if the input and output modules of the internal device is protected. The reason is that two attributes change order.

No visualization of Safe Range for external axes in Visual SafeMove for SafeMove Basic or Pro

When Safe Range is used to limit the axis range of an external axis such as a track motion, there will be no visual indication of the actual range in the graphic view.

Visual SafeMove windows can be re-opened from the Quick Access Toolbar menu

Any windows that are closed can be re-opened using the Quick Access Toolbar menu, as the command Default Layout does not recover these windows.

SafeMove Tool Zone visualization in Online Monitor for robots with external axes

Only TCP robots and track mounted robots will be visualized in the Online Monitor, no other external axes or positioners.

As a consequence, the Online Monitor may show the robot in a non-violating position, even though the safety controller has detected a safety violation and stopped the robot.

5.2 Online

Individual RAPID tasks cannot be stopped for RobotWare 5.60 and later

When running multitasking systems, it is not possible to start and stop individual tasks with the dropdown menu of the task node in the Controller browser. This is due a restriction introduced with RobotWare 5.60 and later.

However, from RobotWare 6.03 onwards, then RAPID tasks to execute or to stop can be selected from RobotStudio RAPID tab.

FlexPendant Viewer running with automatic reloading

When having FlexPendant Viewer running with automatic reloading of the screens and at the same time jogging the robot with the joystick the robot jogging might halt when the FlexPendant Viewer reloads.

5.2.1 Online – Paint

Backup for Paint systems does not create backup of the PIB for IRC5P with RobotWare 5.xx

The Backup function of RobotStudio does not create a backup of the PIB board of the IRC5P system when running RobotWare 5.xx.

Workaround: Create the backup of the PIB board with the FlexPaint Pendant using an USB-stick.

Go Offline does not work for Paint systems

The Go offline function will not create a working Virtual controller system for Paint system unless the Paint package I/O option is set to Simulated.

5.2.2 Online – Integrated Vision

***RobotStudio may hang for up to 60 seconds when configuring jobs with PatMax 1-50**

The user interface of RobotStudio may freeze for up to 60 seconds when configuration Integrated Vision jobs with the tool PatMax 1-50.

Workaround: Use PatMax 1-10 instead.

Remaining error – New Emulators

New camera models have been added to the camera emulator option in RobotStudio 6.04.01. Some of these new models are not yet fully compatible. Our recommendation is to choose a camera model from the 7000 series which is fully compatible with Firmware version 4.10.2.

Emulated cameras not discovered when controller in Motors On

For RobotWare 5.61 onwards, the camera discovery mechanism is disabled when the controller is in Motors On. As a consequence, the camera nodes will not appear in the controller browser.

Workaround: Switch to Manual Reduced Speed and use the Refresh command on the Integrated Vision node in the browser to make the cameras appear.

Information – Integrated Vision only works on 32-bit installations

It is not possible to use Integrated Vision in the 64-bit version of RobotStudio.

Information – Camera firmware version and update

The minimum firmware version to be used with Integrated Vision is 4.08. If this version is not available for a specific camera model, then the newest version available shall be used.

There are two important things to know before upgrading a sensor

- The user must make sure to first backup the files on the camera. This can be done using the Rapid snippets for camera backup/restore, or the FlexPendant Explorer.
 - The latest available firmware version may vary across sensor types. However, when the firmware update utility presents the latest available version it shows the firmware with the highest version number which may not apply to the sensor to be updated. However, the appropriate firmware will be applied.
-

Information – The spreadsheet view

The spreadsheet view is not enabled when editing in the in the following modes “Add part location tool”, “Add part inspection tool”. Before entering the spreadsheet mode click for example “Setup Image” or Output to Rapid.

Information – Calibration board without fiducial

When using the calibration boards, checkerboard or board with dots, the user must select the preferred origin by clicking and accepting (press enter) three points on the board. Only after these three points have been selected is it possible to click “calibrate” to execute the calibration.

Information - Use default camera settings

If the camera is not using default communication settings the result may be that RAPID instructions return error code “Communication Error”. The safest method to get default settings is to go to Connect->Add Sensor Right click and select “Show all sensors”. Select the device to reset and click “Apply factory settings” in the lower right corner. The most important settings are:

Telnet port: 23
User: "admin"
Password: ""

Information – User Credentials

It is now possible to create user profiles with different access levels on the camera. For detailed information about this, please refer to the Integrated Vision User Manual.

Remaining error – Save image on camera

It is not possible to save an image on the camera using "Save Image". This is by design, but the dialog still allows the user to try to do this. The result is that the image is not saved and no error message is given.

Remaining error - Connect button greyed out for no reason

It may sometimes happen that the "Connect" button is greyed out, with the tooltip saying the camera is not on the correct subnet although the IP settings are OK.

Workaround: Restart the Integrated Vision Add-In.

Remaining error – VC started from Controller->Add controller does not detect cameras

A VC that is started from Controller->Add controller does not detect cameras on the network, even if the VC_network_definition.xml is correctly configured and the firewall is turned off. The reason is that the controller is not able to detect new cameras on the network when it is in "Motors On" state. When the VC is started stand-alone in RobotStudio it is automatically set to "Motors On" when started.

Workaround: To allow it to discover cameras, turn the control panel key to manual mode or launch the VC as part of a station.

User tip - Removing cameras from configuration

To remove a configured camera from the list of configured cameras, use the configuration editor. Enter *Configuration->Communication->Application Protocols* and remove the desired camera. Perform a warm start to complete the operation.

User tip – Viewing all cameras present on the network

Connect->Add Sensor is normally used for setting the IP addresses of sensors that are not currently on the correct subnet (192.168.125.X). Since the dialog shows all cameras "seen" by the PC, this dialog is useful when error tracing camera network problems.

If a camera does not appear on the network using the "Add sensor" dialog as suggested above, it is advisable to cycle the power of the camera. If the camera receives power from the controller, then cycle power by turning the mains switch.

User tip – Warm start the controller after changing network settings

Whenever changing the network settings of the camera, either from Connect->Add Sensor or Connect->Network settings, it is important to warm start the controller. If this is not done, RAPID instructions will give the error "Communication Error" and the FTP-mounted camera disk is not accessible. If DHCP address is used and persist, please try a static address instead.

5.3 Offline

*Event “Not allowed command” may be shown in the output window

When starting a Virtual Controller with RobotWare 5, the eventlog message “Not allowed command” may be displayed in the output window. This message can safely be ignored.

*Live update of Signal Analyzer may cause lag.

When running Signal Analyzer with live update for virtual controllers, the graph rendering may cause lag and slow the simulation down. As a workaround, switch windows back and forth to force an update of the graph rendering of the Signal Analyzer.

The robot IRB 1600ID 1.55 m / 6kg replaced by IRB 1660ID1.55 m / 6 m in RobotWare 6.04

The robot IRB 1600ID 1.55 m / 6 kg is not available in RobotWare 6.04 and later. It has been renamed to IRB 1660ID 1.55 m / 6 kg. Virtual controller systems for IRB 1600ID 1.55 m / 6 kg based on RobotWare 6.03 cannot be upgraded to RobotWare 6.04 and later. This means that Pack&Go files for this robot based on RobotWare 6.03 cannot be upgraded to RobotWare 6.04 automatically.

Workaround: Re-build or modify the virtual controller system to use IRB 1660ID 1.55 m / 6 kg instead when using RobotWare 6.04 or later.

FlexPendant and RAPID applications run with logged in user rights

A FlexPendant or RAPID application running on the virtual controller runs with the rights of the logged-in Windows user. RAPID applications running in a background task will start to execute when the Pack&Go file is opened and FlexPendant applications will start to execute when the user starts the Virtual FlexPendant.

A warning message has been added to the Unpack&Work wizard to make the user aware that only Pack&Go files (.rspg) from trusted sources shall be opened.

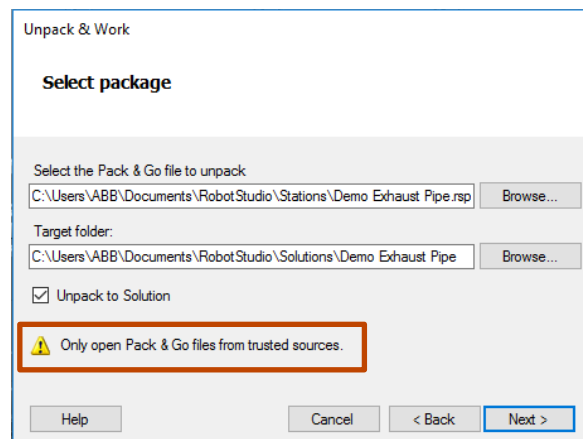

Compatibility of RobotStudio Library and Stations with older RobotStudio versions

RobotStudio is generally **not forwards compatible**, i.e. it is not possible to load stations or libraries created in RobotStudio 6.04 into an earlier version of RobotStudio such as e.g. RobotStudio 5.x, 6.03.02 or earlier. However, RobotStudio is **backwards compatible**, which means stations and libraries created in versions 5.x, 6.03.02 or earlier can be opened in RobotStudio 6.04.

TrueMove path visualization fails for customized zone data.

The TrueMove path visualization function only supports predefined zonedata. It will not work for user defined zonedata.

Backup fails for RobotStudio solutions with SafeMove or Electronic Position Switches

Backups are automatically created for virtual controller systems that are part of a RobotStudio solution when saving the station. For virtual controller systems with the RobotWare options *SafeMove* or *Electronic Positioning Switches* the backup will fail since these systems contain files that are read-only. As a result, an error message is presented in the output window: “<System name>: Backup failed”. The station will be successfully saved but there will be no backup created.

Workaround: Ignore the error message “<System name>: Backup failed” and create a manual backup whenever needed. The RobotStudio Option “Enable automatic backup of controllers in solution” that is available in RobotStudio Options -> Robotics -> Virtual Controller” can be de-selected to disable the backup function.

IRB 14000 cannot be combined with any other robot

The function system from layout fails if trying to create a MultiMove system where one robot is an IRB 14000. The reason is that the IRB 14000 cannot be combined with any other robot.

Workaround: Create a separate system for the IRB 14000.

The Work Envelope function does not support IRB 14000

The function is disabled for the IRB 14000 and cannot be activated.

The 2D work envelope fails for certain robot models

As a result, the generated work envelop may appear distorted.

Update of current selection in the 3D graphics window may be delayed

A problem related to the graphics driver has been observed on certain PCs. The problem is that the update of the current selection in the 3D graphics is delayed until the next redraw.

Workaround: Add or uncomment the following line in the file *RobotStudio.exe.config*

```
<add key="DoublePresentWorkaround" value="true" />
```

Failure to open Pack&Go file to same folder the second time

RobotStudio will prevent Pack&Go files to be opened to the same folder a second time if the station contains VC systems with the EPS or SafeMove option. This is by design to prevent the safety controller configuration file to be accidentally overwritten.

Workaround: Remove the write protection manually using *Windows Explorer*.

Updates of instruction template and code snippets

RobotStudio will not automatically update the user files for instruction templates and code snippets files in the folders:

...\My Documents\RobotStudio\Instruction Templates

...\My Documents\RobotStudio\Code snippets

Workaround: The user has to manually copy the latest files from

%ProgramFiles%\ABB Industrial IT\Robotics IT\RobotStudio 5.xx\Instruction Templates,

and

%ProgramFiles%\ABB Industrial IT\Robotics IT\RobotStudio 5.xx\Code Snippets

to the data folder.

IO signals configured with access level 'DEFAULT'

When IO signals are configured with access level 'DEFAULT', only input signals are possible to set/reset from the I/O Simulator and I/O Window. To be able to affect also output signals, set the access level to 'ALL' for them in the Configuration Editor.

VC does not start with RRI option and GSI folder structure missing.

The VC will hang when started with a system containing the RobotWare option *RRI* (Robot Reference Interface) if the GSI folder structure is missing.

Workaround: create GSI Folder before starting the VC inside the HOME directory of the system. See the Application Manual for Robot Reference interface for more information.

System in Guard Stop state in Automatic mode after run-time error

Certain run-time errors may cause the controller system to enter *Guard Stop* state in *Automatic* mode. This is the same behavior as in a physical robot controller system. This typically happens when a run-time error related to Conveyor Tracking occurs. A simulation cannot be started when the controller is in this state.

Workaround: To reset the controller state, open the Control Panel window and first switch to *Manual mode*, and then back to *Automatic mode*.

Information message starting system with IRB260/460/660/760

Starting a system with IRB260/660 gives you an error message: *'The number of joints is different between the library model and the controller configurations'*. The reason is that the IRBx60 is modeled with six joints in RobotStudio of which two are locked, but has four joints in the VC

Path handling of instructions with multiple joint targets

The path functions Rotate, Translate, and Mirror do not work as expected with instructions containing via points as jointtargets. The functions will leave the jointtargets as is. Interpolate Path gives an Unknown Error and Tool Compensation reports an error message

Event Manager: Simulation cannot be triggered by analog system signals

The event manager only supports analog station signals, not analog system signals

Conveyor Tracking***Conveyor objects must be re-added for stations created prior to RS 6.05.**

When opening stations with conveyor tracking created prior to RobotStudio 6.05, conveyor objects must be re-added.

Incorrect default values for c1Position and c1Speed for RobotWare 5 with the PaintWare option

The default values for the parameters *c1Position* and *c1Speed* may become incorrect for a virtual controller system. The symptom is that its attribute values are all zero, see snapshot below.

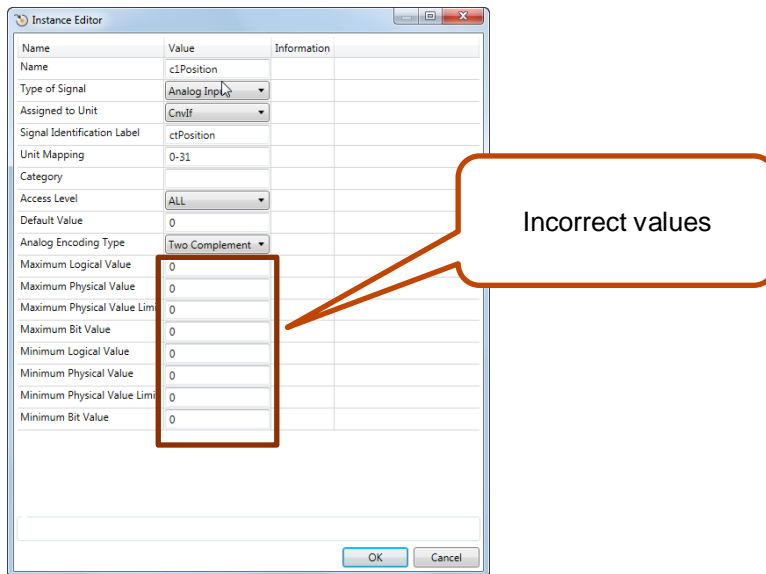

Workaround: Save the following lines to a CFG file named 'TEMP.CFG' or similar and load in the virtual controller followed by a restart.

```
EIO:CFG_1.0:5:0::
#
EIO_SIGNAL:

-Name "c1Position" -SignalType "AI" -Unit "CnvIf"\
-SignalLabel "ctPosition" -UnitMap "0-31" -Access "ALL"\
-MaxLog 21474.8 -MaxPhys 1 -MaxPhysLimit 1\
-MaxBitVal 2147483647 -MinLog -21474.8 -MinPhys -1 -MinPhysLimit -1\
-MinBitVal -2147483647

-Name "c1Speed" -SignalType "AI" -Unit "CnvIf" -SignalLabel "ctSpeed"\
-UnitMap "32-63" -Access "ALL"\
-MaxLog 21474.8 -MaxPhys 1 -MaxPhysLimit 1\
-MaxBitVal 2147483647 -MinLog -21474.8 -MinPhys -1 -MinPhysLimit -1\
-MinBitVal -2147483647
```

5.3.2 Station Viewer

Memory problem when doing Save As Viewer or Record to Viewer with large stations

RobotStudio may run out of memory (*OutOfMemory exception*) when doing **Save As Viewer** or **Record To Viewer** if the station is very large.

Workaround: Use the 64-bit version of RobotStudio and create a 64-bit viewer by ticking the checkbox in the Save As Viewer file dialog.

5.3.3 MultiMove

MultiMove error: 'Object reference not set to an instance of an object'

When the Test Play button is pressed in the MultiMove tool, the following error message may be displayed: 'Object reference not set to an instance of an object', but the robot moves and the Status 'Calculation OK' is displayed. In addition, when 'Create Paths' is pressed the following message is displayed: 'Can't create paths : Value cannot be null', and no paths are created. In the 'Create Paths Settings', is the WP TCP drop down empty.

Reason: Workobject is not set for the current task

5.3.4 External Axis

Error 50091: 'Restart not possible' after warm start of a system with external axis

When restarting a system with activated mechanical units the activation state is lost. Then the program can no longer be started from the Virtual FlexPendant, the RAPID Editor or the RAPID Tasks window.

Workaround: Reset the program pointer ('Program Pointer to Main') before starting the program from the Virtual FlexPendant, the RAPID Editor or the RAPID Tasks window, or, start the program from the Simulation Play button.

5.3.5 Network Drives and UNC Paths

RobotStudio on computers with roaming user profiles

RobotStudio may fail on PC configurations with roaming user profiles, i.e. when the users' documents folder resides on a server and not on the local disk.

Workaround: Redefine the 'User Project Folder' to a folder on the local disk (File → Options → General → Files&Folders → User Project Folder).

Virtual Controller does not support UNC paths

UNC paths cannot be used to locate Virtual Controller systems. Using UNC paths for VC systems will cause the log message 'Failed to initialize FW upgrade framework' to appear when the system starts. Subsequent attempts to work with the VC such as synchronizing RAPID data will fail.

Creating and starting systems located on a network drive

When using a network drive to store RobotStudio data such as RobotWare systems or the RobotWare mediapool, the following problems may occur

- Virtual controller does not start
- Not possible to open Virtual FlexPendant

Cause: By default, the .NET Framework does **not** allow execution of code from a remote file system. This means the application may behave unexpectedly if the media used by the system or the system itself resides on a network share.

Workaround: To resolve this, the user must explicitly grant the required permissions:

1. Open the file Virtual FlexPendant.exe.config located in

C:\Program Files (x86)\ABB Industrial IT\Robotics IT\RobotStudio 5.61\Bin

2. Add the following lines

```
<?xml version="1.0"?>
<configuration>
  <startup useLegacyV2RuntimeActivationPolicy="true">
    <supportedRuntime version="v4.0" sku=".NETFramework,Version=v4.0"/></startup>
    <runtime>
      <loadFromRemoteSources enabled="true"/>
    </runtime>
  </configuration>
```

```
<!-- THIS IS ONE OF THE NEW LINES!!! -->
<!-- THIS IS ONE OF THE NEW LINES!!! -->
<!-- THIS IS ONE OF THE NEW LINES!!! -->
```

The Virtual FlexPendant must be restarted for the changes to take effect.

For further information, see

[http://msdn.microsoft.com/en-us/library/dd409252\(v=vs.100\).aspx](http://msdn.microsoft.com/en-us/library/dd409252(v=vs.100).aspx)



Note

Windows security settings may prevent the file from being directly edited in the default location. Copy the file to your local Documents folder to edit it. Upon completion, you need to manual copy the file back to its original location.

5.3.6 RAPID

Robtargets that are LOCAL to a PROCEDURE cannot be synchronized with RobotStudio

The RobotStudio synchronization engine that translates 3D data of the station to RAPID code and vice versa does not support robtargets that are declared locally to a procedure.

Workaround: *Declare the robtargets as global or local to a module instead.*

Robtarget names must be unique in RAPID even if they are LOCAL

RobotStudio requires that robtarget names are unique for the RAPID synchronization to work properly, i.e. you cannot have a global robtarget named pMyTarget1 in module A and a local robtarget with the same name in Module B.

Global robtargets cannot be made local through Synchronization to VC

Global robtargets cannot be changed to local through *Synchronization to VC*, the option is disabled (PDD 3140).

Workaround: *Change the robtargets to module local in the RAPID Editor and Synchronize to station.*

Error Message: Sync. to Station completed with errors

Error Message: Sync to Station completed with errors: New data <name> <type> has same name as existing object in same block <routine>.

When this error message appears, there is a storage type mix-up between data already stored in RS and in the VC. Because of this, and per design, the data is not considered the same data.

Workaround: *1. Ensure all data declarations have the same definition in RS as in RAPID (there is no user interface for this).*

2. Sync to station should now work.

3. Sync back to controller, and remember to change the data declarations back to what you want.

5.3.7 Paint

The new conveyor tracking module DSQC2000 is not supported for paint robots.

The new conveyor tracking module DSQC2000 is not supported for paint robots.

Lack of Virtual Controller support for the Paint systems

Paint systems that are configured using the Paint package I/O option Discrete, Compact or Fieldbus, will result in a SysFail state.

Workaround: *Re-create the system with the simulated I/O option.*

5.3.8 Graphics and Geometry

***First character of part name incorrect when importing assemblies or converting files**

The first character of part or assembly names may become incorrect when importing CAD parts or assemblies into a RobotStudio station. The error only occurs on Windows 7.

Some CAD converters not available in Premium trial license

No trial license available for CAD converters for DXF/DWG, JT, NX, Parasolid, Solid Edge, and SolidWorks.

Enforce selected graphics device for PCs with multiple graphics cards

For best performance when running RobotStudio on a PC with multiple graphics cards, RobotStudio can be configured to use a specified device. By this option you can ensure maximum performance. This is useful for e.g. Lenovo W540 that has both an integrated Intel graphics device and a discrete NVIDIA card.

Open the file RobotStudio.exe.config that is located in the folders

C:\Program Files (x86)\ABB Industrial IT\Robotics IT\RobotStudio 6.0\Bin64
and

C:\Program Files (x86)\ABB Industrial IT\Robotics IT\RobotStudio 6.0\Bin
and uncomment the line

```
<add key="GraphicsDeviceType" value="Discrete"/>
```

Valid values are 'Discrete', 'Integrated' and 'Warp' (software renderer).

Note that there are two different files, one for the 32-bit version, and another for the 64-bit version.

Problems when undoing Boolean operations on Geometry

Undoing a Boolean operation might not succeed. To recover from these problems, you need to delete the items that caused the problem.

Out of memory

The application might fail when out of memory due to the import of very large ACIS files or load of very large stations.

Workaround: Use the 64-bit version that can handle more memory. Ensure that you have enough memory installed on the PC, see System Requirements.

5.4 ScreenMaker Limitations

A ScreenMaker application may fail to build if the DPI setting is not set to 100%

Certain UI controls in ScreenMaker may fail to build correctly if the DPI setting is not set to 'Smaller – 100%'.

Symptom: The error message caused by this problem will read '*System.Drawing.Font* does not contain a constructor that takes 2 arguments'.

Workaround: Set DPI to 100% on your PC.

File changes to FlexPendant applications does not load the changes until a FlexPendant reset

With RobotWare 6.0x the controller's restart will no longer reset the FlexPendant memory. This was part of an effort to improve the restart time of the controller.

This means that after placing a new FlexPendant application file(s) on the FlexPendant unit, you need to manually reset the FlexPendant for it to reload its assets.

To manually reset the FlexPendant you need to use the reset button on the FlexPendant's backside. (See Operating Manual – IRC5 with FlexPendant, 3HAC16590)

Running Routine with Movement

RunRoutine Button control does not always work correct when a routine with movements is called.

As a workaround use instructions like StopMove, StorePath, RestorePath and StartMove to control the movements of the robot.

A Trap routine could be called with a normal button control and in the Trap the above instructions can be used to control the movements of the robot.

PictureBox control as a Widget

If a Picture Box control is created as a widget from a Windows 8 operating system, the control is not shown on the FlexPendant. The behavior is fine with any other operating system like Windows 7.

6 RobotWare Compatibility

6.1 General

Supported RobotWare versions

RobotStudio is distributed with the corresponding version of RobotWare and works with RobotWare 5.07 and later. Please check details below.

6.2 RobotWare 5.05 and 5.06 Compatibility

RobotWare 5.05 and 5.06 including revisions thereof are not supported by RobotStudio 5.15 and later versions. Please use the corresponding version of RobotStudio for managing robot controllers with any of these RobotWare versions.

6.3 RobotWare 5.07 Compatibility

RobotWare 5.07 and its revisions of are supported with the following limitations:

General

The location of the program pointer is not updated in the RAPID Editor during program execution.

Offline

A limitation in the versions 5.07.02, 5.07.03, and, 5.07.04 of RobotWare may cause the Virtual Controller to System Failure state during I-start on certain computers. The problem is due to the ctrl.bin-file not being correctly created.

Workaround: Create an empty ctrl.bin file in the INTERNAL folder of the controller system, and then perform a warm start.



Note

The problem will reappear if the system is I-started.

The virtual controller does not support RobotWare 5.07.08 and RobotWare 5.07.07.

Online

FlexPendant Viewer does not work RobotWare 5.07

6.4 RobotWare 5.08 Compatibility

RobotWare 5.08 and its revisions of are supported with the following limitations:

Offline

RobotWare 5.08 is not supported.

Workaround: Use RobotWare 5.08.01 or later.

6.5 RobotWare 5.10 Compatibility

RobotWare 5.10 and its revisions of are supported with the following limitations:

Offline

Starting a controller will generate internal UAS error in controller error log.

6.6 RobotWare 5.11 Compatibility

RobotWare 5.11 and its revisions of are supported with the following limitations:

Offline

Linear jogging of a robot across joint values that will cause a change of confdata may fail. For example, if the robot is jogged linearly when joint values is passing 90 degrees for axis 1 may cause the robot to stop or to change configuration.

6.7 RobotWare 5.12 Compatibility

RobotWare 5.12 and its revisions of are supported with the following limitations:

Paint backups from RW 5.12.01 not compatible with RW 5.12.02 or later

Restoring a paint system backup from RobotWare 5.12.01 will cause SysFail for RobotWare 5.12.02 or later

Workaround: Add the following parameters to the configuration files

EIO.CFG:

```
EIO_SIGNAL:
    -Name "doMainInMC" -SignalType "DO" -Unit "SysComm" -UnitMap "44"
    -Name "AlHVErrNo" -SignalType "GO" -Unit "SysComm" -UnitMap "150-151" \
    -Access "ALL"
    -Name "AlHVEEn" -SignalType "DO" -Unit "SysComm" -UnitMap "155" \
    -Access "ALL"

EIO_CROSS:
    -Res "AlHVEEn" -Act1 "HVEEnabled"
```

SYS.CFG:

```
CAB_TASK_MODULES:
    -File "INTERNAL:/pntrapid/T_ROB1/cycinfo.sys" -ModName "cycinfo" \
    -Task "T_ROB1"
    -File "INTERNAL:/pntrapid/csvlkup.sys" -ModName "csvlkup" -AllTask \
    -Hidden
```

6.8 RobotWare 5.13 Compatibility

RobotWare 5.13 and its revisions of are supported with the following limitations:

Paint backups from RW 5.12.02, 5.12.03 or RW 5.13 or 5.13.01 not compatible with RW 5.13.02 or RW 5.13.03

There are several changes in the configuration database for I/O (EIO.CFG) and Controller (SYS.CFG) that will cause System Failure if an old backup is loaded. There are also changed in installed RAPID modules. To create a compatible configuration, proceed as follows:

1. Create and start a VC with a RobotWare 5.13.03 system containing the same options as your original backup, but do not load the backup.
2. Save the EIO.CFG and SYS.CFG to file.
3. Compare the saved files with the corresponding files of your backup. (You can use a text file comparison tool for simplification.)
4. Add your system-specific configuration to the general configuration files saved from the 5.13.01-system using a text editor.
5. Replace the files of the original backup with the corresponding modified configuration files.
6. Go through the RAPID modules of the backup and remove the default modules (i.e. those that are not changed by the user).
7. Load the backup and restart the system. You are done.

6.9 RobotWare 5.15 Compatibility

Signal Analyzer Online

The feature Signal Analyzer Online requires RobotWare 5.15.03 or later.

6.10 RobotWare 6 Compatibility

Overview

RobotWare 6.00 and 6.00.01 systems cannot be directly upgraded to RobotWare 6.01. To upgrade a system, you need to create backup and migrate it using the tool '*Migrate Backup or Folder*', then recreate the system and finally, restore the backup.

For this reason, the functions '*Unpack&Work*', '*Go Offline*' and '*New Solution with Station and Robot Controller – From backup*' are blocked to prevent upgrade from RobotWare 6.00 or 6.00.01 to RobotWare 6.01.

RobotStudio, however, is compatible with both RobotWare 6.00 / 6.00.01 and 6.01.

6.11 General Compatibility Limitations

Safety Configuration

Safety configuration of a track motion IRC5 system equipped with a safety controller of type EPS or SafeMove can be done without the need to read track motion parameters manually when using RobotWare 5.11.01 or later. Encrypted parameters needed by the safety controller will be automatically read by EPS Wizard and SafeMove Configurator, respectively.

Configurations

The feature **Configurations** for selecting the robot arm configuration (confdata) may fail, or not present all solutions, in some specific circumstances even when the target is reachable if RobotWare 5.14 or earlier is used.

Workaround: Upgrade to RW5.14.01 or later

6.12 ScreenMaker Compatibility

RobotWare

It is possible to use previous RobotWare versions, but with some limitations.

- ActionTrigger will work only on RobotWare 5.12.02 or later.
- The controls *Button*, *TpsLabel* and *PictureBox* controls was modified in RobotStudio 5.13. The property '*Allow MultipleStates*' of these controls can be accessed from RobotWare 5.13 and later.
- Variant Button will work only on RobotWare 5.14.01 or later
- Conditional Trigger will work only on RobotWare 5.14.01 or later
- Widgets will work only on RobotWare 5.60 or later.

FlexPendant SDK

ScreenMaker should be used with FlexPendant SDK 5.12.02 or later. ScreenMaker allows selection of FlexPendant SDK version when it is launched. If only one version of FlexPendant SDK is available in the system, it is loaded by default.

6.13 Support for future RobotWare versions

RobotStudio 6.08.01 supports all future minor revisions of RobotWare 6.08, but no future major releases. For example, RobotStudio 6.08.01 will support RobotWare 6.08.02 (if, and when available) but not RobotWare 6.09 or later.