

Photometer applications in an acetic acid process

PIR3502 Multiwave process photometer



Increase the efficiency and safety of the acetic acid process.

Measurement made easy

—
PIR3502
IR process photometer

Industries

Chemical | Refining

Introduction

Acetic acid is a large volume organic acid produced in petrochemical plants. Approximately half of the acetic acid produced is used to make vinyl acetate adhesives. Acetic acid is also used in the manufacture of cellulose acetate fibers and water-based latex paints. The carbonylation of methanol is a synthesis route commonly used to make acetic acid. The ABB PIR3502 process photometer can continuously measure key components in the acetic acid process which are used for process control and safe operation of the plant.

The analyzer

The ABB Multiwave process photometer is a multiple channel, fixed wavelength photometer that can accommodate up to eight different optical filters. It ratios the energy from a measure wavelength filter (where the component of interest absorbs energy) to a reference wavelength filter (where none of the components absorbs energy). Infrared (IR) and near infrared (NIR) photometers are used to measure the key components in the acetic acid process. These photometers have established an excellent reputation for reliable and stable performance in acetic acid plants.

ABB process photometers provide fast response time and allows quick remedial action when the measured components are off specification.

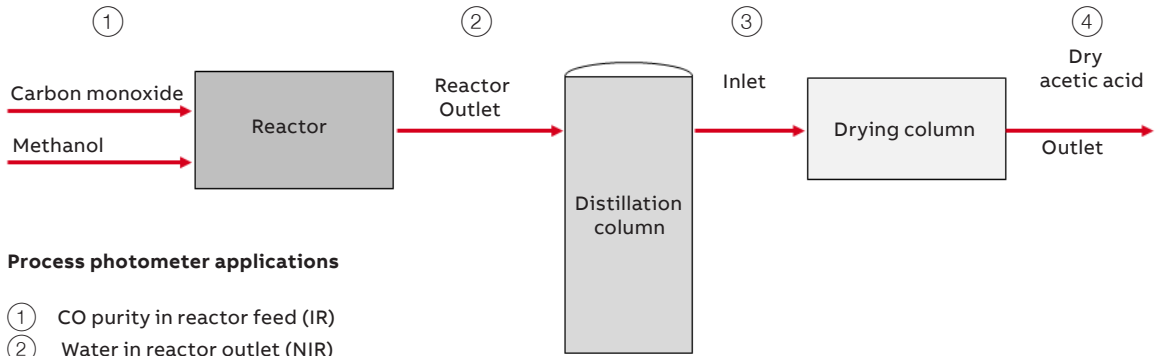

Process photometer applications

- ① CO purity in reactor feed (IR)
- ② Water in reactor outlet (NIR)
- ③ Water in drying column inlet (NIR)
- ④ Water in drying column outlet (NIR5)

Discussion

A common synthesis route for the manufacture of acetic acid is the carbonylation of methanol by the following reaction:

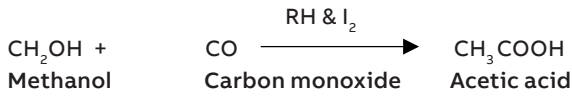

A schematic of the acetic acid process is shown on the previous page. The efficiency and safety of the acetic acid process can be monitored by the following analyses with the ABB process photometer:

Measurement	Range	Photometer
Carbon monoxide	80 to 100 %	PIR3502
Water in reactor outlet	0 to 20 %	PIR3502
Water in drying column inlet	0 to 10 %	PIR3502
Water in drying column outlet	0 to 1500 ppm	PIR3502

Conclusion

The use of ABB Multiwave process photometers increases the efficiency of the acetic acid process. The fast response time of the photometer allows for quick remedial action when the measured components are off specification.