

**50US3000
Ultrasonic
Transmitter**

**INSTALLATION INSTRUCTIONS
OPTIONAL CHART RECORDER
MOUNTING KIT**

**2 INCH PIPE-MOUNT KIT
PART NO. 614C114U01
INSTALLATION INSTRUCTIONS**

This Kit contains all the parts necessary (except where indicated in FIGURE 1) to install the optional chart recorder to a customer-supplied 2-inch pipe support.

These instructions cover only the operations necessary to install the parts in the pipe-mounting kit. Refer to the associated 50US3000 Instruction Manual and any Technical Information for information on equipment operation, trouble shooting and safety precautions. If required, copies of these documents are available from ABB Automation at the address shown below.

Servicing of the equipment should be restricted to authorized personnel who have been trained in the operation and maintenance of this equipment.

Contact the following address in the event of any problems or questions:

**ABB Automation Inc.
Instrumentation Division
125 E. County Line Rd.
Warminster, PA 18974-4995
Tel: (215) 674-6000**

ASSEMBLY PROCEDURE

- Refer to FIGURE 1 for all component and mounting references.
- Place the mounting bracket supplied with the Recorder in the position shown.
- Thread the 2 set screws (Item 2) into the 2 spacers (Item 1)
- Thread the 2 spacer assemblies (consisting of Items 1 and Items 2) into the Recorder through the Mounting Bracket.
- Place the 2 U-Bolts supplied in the Mounting Kit through the bracket. Place the 4 flat washers, 4 spring washers and 4 hex-nuts loosely on the ends of the U-Bolts.
- Place the entire recorder/bracket assembly over the 2-inch pipe stand (supplied by customer).
- Adjust the recorder assembly to the desired position and tighten the hex-nuts until the U-Bolts firmly secure the Recorder assembly to the pipe.
- Place the 4 spacer washers (Item 3) supplied with the Kit on both sides of the Sun Shield supplied with the Kit and insert the 2 hex bolts (Item 4) supplied through the washers and Sun Shield.
- Secure the Sun Shield Assembly to the Recorder Assembly by threading the 2 hex bolts into the two spacer assemblies on the Recorder bracket

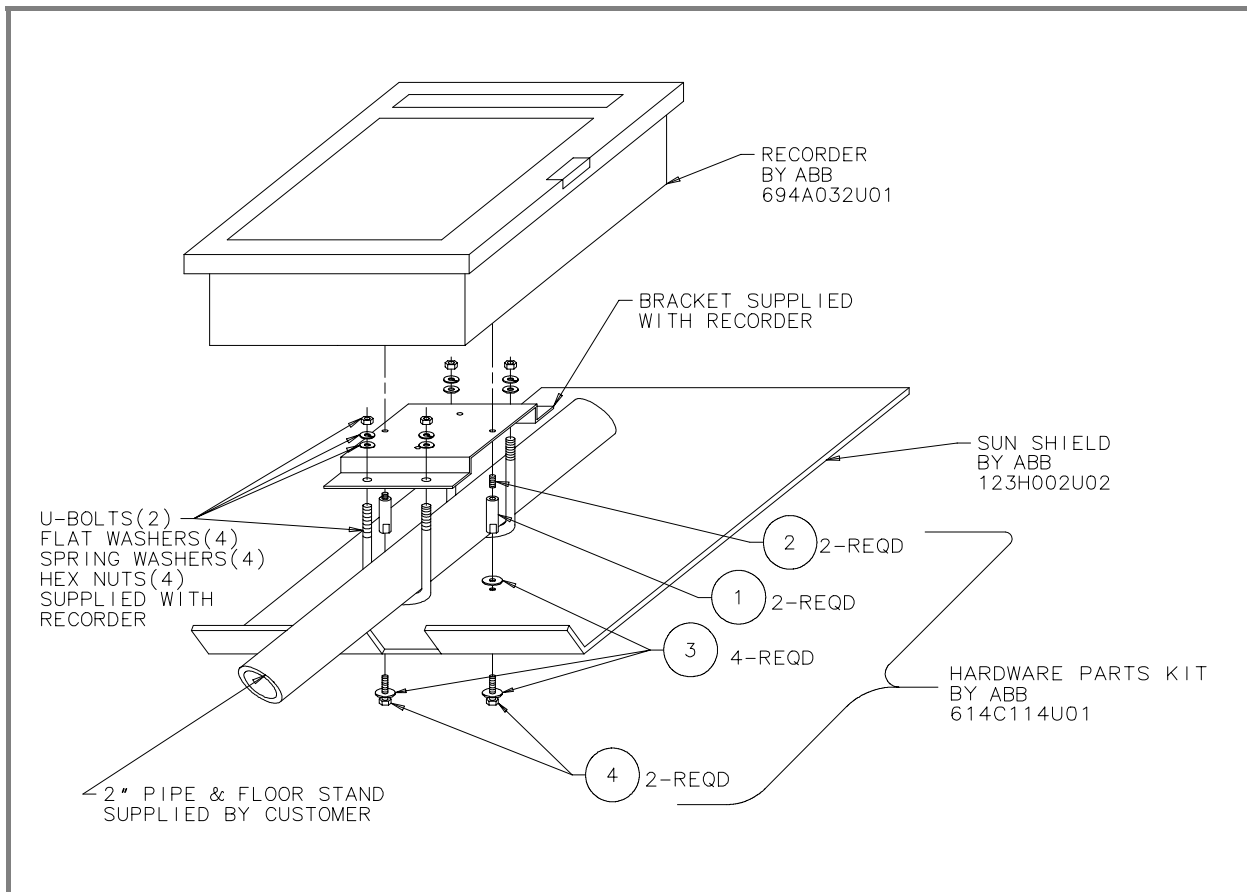

FIGURE 1 - RECORDER MOUNTING INSTRUCTIONS