

SOFTSTARTER TYPE PSE

Fieldbus Communication

Fieldbus Plug Modbus RTU



PREPARED 2021-07-28	STATUS Approved	SECURITY LEVEL Public		
RELEASED 2021-07-28	DOCUMENT KIND Manual			
OWNING ORGANIZATION Motor Starting & Safety Softstarters	DOCUMENT ID. 1SFC132068M0201	REV. C	LANG. en	PAGE 1/18

© Copyright 2019 ABB. All rights reserved.

Contents

- 1. Modbus RTU 3**
- 2. Fieldbus Plug Kit Installation..... 4**
- 3. PSE Data..... 6**
 - 3.1. Digital input telegram 6
 - 3.2. Digital output telegram.....7
 - 3.3. Analog input telegram.....7
 - 3.4. Diagnostics 8
 - 3.4.1. Diagnostic data 8
 - 3.4.2. Modbus diagnostic data 9
 - 3.5. Parameters10
 - 3.5.1. Configure baud rate 11
- 4. Modbus RTU – a set-up example 11**
 - 4.1. Softstarter PSE Fieldbus plug Modbus RTU communication..... 11
 - 4.2. Settings.....12
 - 4.3. Read digital input telegram.....12
 - 4.4. Write digital output telegram13
 - 4.5. Read analog input telegram14
 - 4.6. Read diagnostic inputs.....15
 - 4.7. Write parameter data telegram.....16
- 5. Troubleshooting 17**
 - 5.1. Modbus slave does not respond to requests17
 - 5.2. PSE trips on fieldbus fault (EF40).....18
 - 5.3. Motor does not start.....18
 - 5.4. Parameter write does not work.....18
- 6. Contact us18**

STATUS	SECURITY LEVEL	DOCUMENT ID.	REV.	LANG.	PAGE
Approved	Public	1SFC132068M0201	C	en	2/18

1. Modbus RTU

Modbus is a master-slave protocol and only one device can transmit on the line at any time. The master (which in most cases is a PLC) manages the exchanges and only it can take the initiative. It interrogates each of the slaves in succession and no slave can send a message unless it is invited to do so. The master repeats the question when there is an incorrect exchange, and declares the interrogated slave absent if no response is received within a given time period. If a slave does not understand a message, it sends an exception response to the master who may or may not repeat the request.

The Modbus protocol provides full control and status information of the Softstarter and writing of parameters. Through the fieldbus it is possible to start and stop the motor, read out currents and frequency, get information of faults and protections and read device identification.

See chapter 8 in the Installation and commissioning manual, document 1SFC132057M0201, for fieldbus related settings available.

Before the Modbus fieldbus can be taken in operation following parameters must be set in the Softstarter:

- Parameter **FB Enable** set to On
- Parameter **FB Address** set to a free communication address.

The parity and number of stop bits are automatically detected by the fieldbus plug.

The baud rate depends on the configured fieldbus address according to the table below:

Fieldbus address	Baud rate bits/s
1 to 32	9600
33 to 65	19200
66 to 98	57600
99 to 247	19200

If needed, baud rate 1200, 2400, 4800 or 57600 can also be configured (see section 3.5.1).



Caution!

The motor may start unexpectedly if there is a start signal present when doing any of the actions listed below.

- Switching from one type of control to another (fieldbus control/hardwire control)
- Reset all Settings

2. Fieldbus Plug Kit Installation

For technical data and descriptions of the Modbus-RTU MRP21-FBP and MRP31-FBP fieldbus plugs, see document 2CDC194001D0203 available at www.abb.com/lowvoltage.

Below is described how to install the Modbus-RTU MRP31-FBP fieldbus plug.

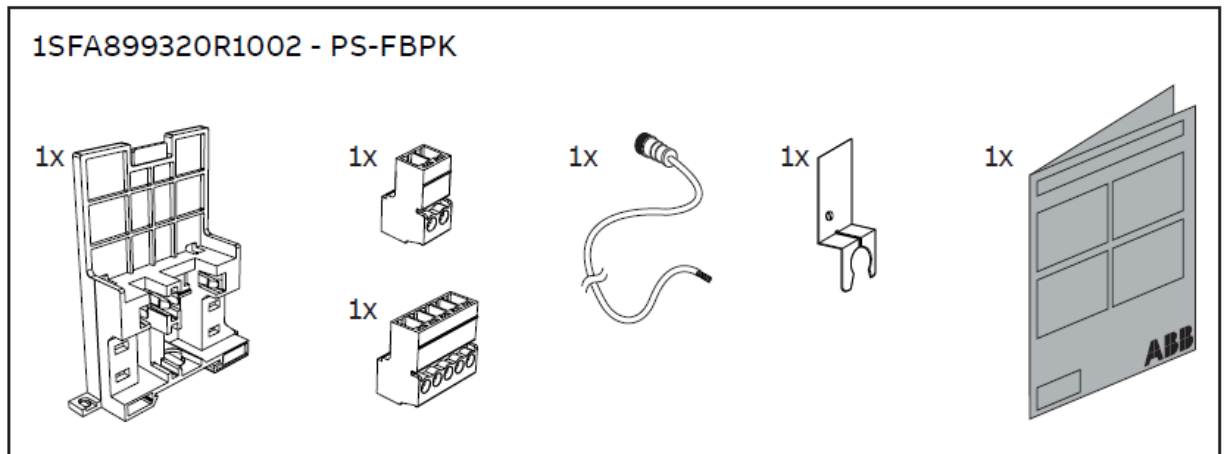
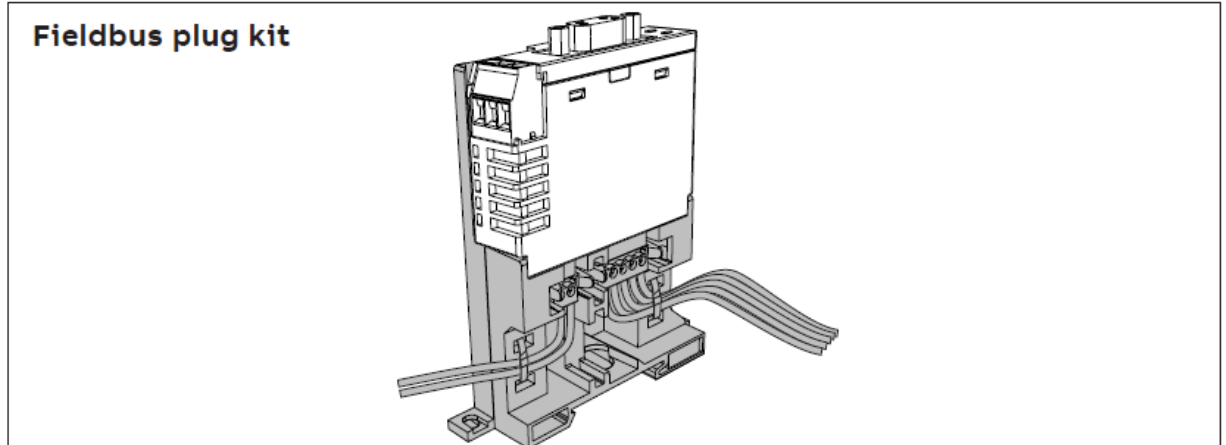

Important information:

A qualified electrician must carry out installation, commissioning and service on the product by following installation standards and regulations. The product uses hazardous voltage that can cause death or serious injury. Always disconnect power before working on equipment. Do not touch terminals when voltage is applied, output terminals can have live voltage even when the device is not running the motor. This product should only be used within the specified ratings. Check that you have the correct product in regards to mains voltage, supply voltage and rated product data.

STATUS	SECURITY LEVEL	DOCUMENT ID.	REV.	LANG.	PAGE
Approved	Public	1SFC132068M0201	C	en	4/18

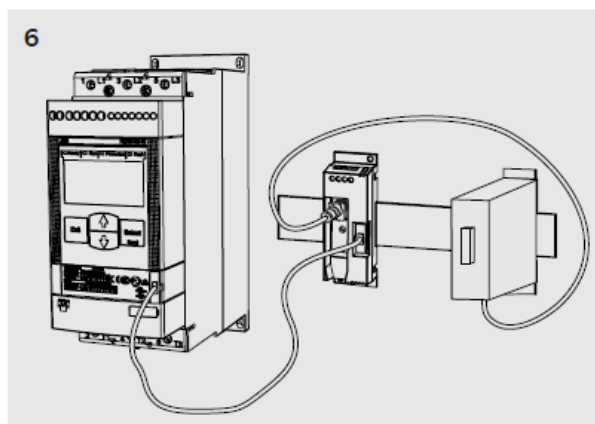
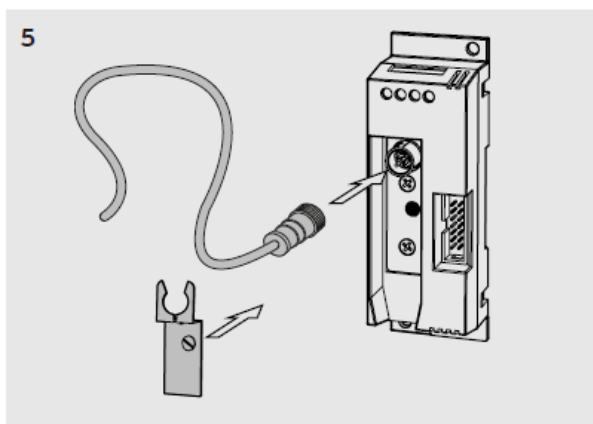
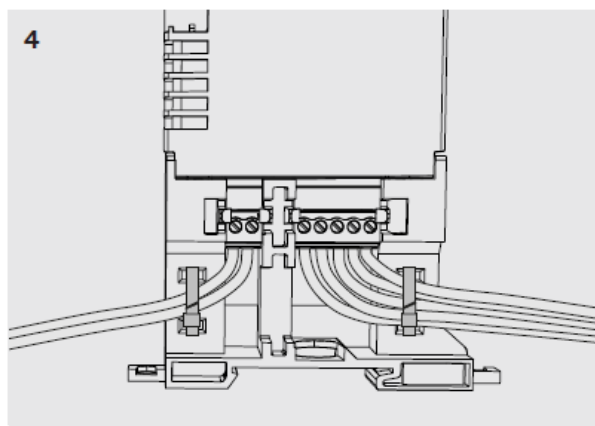
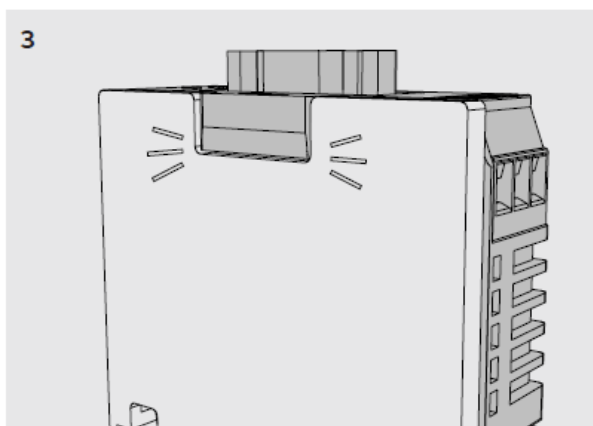
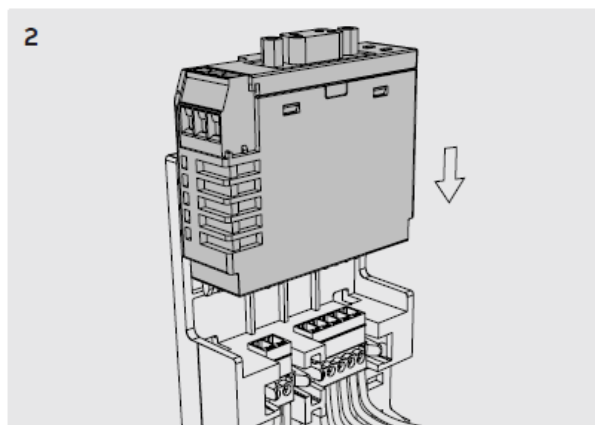
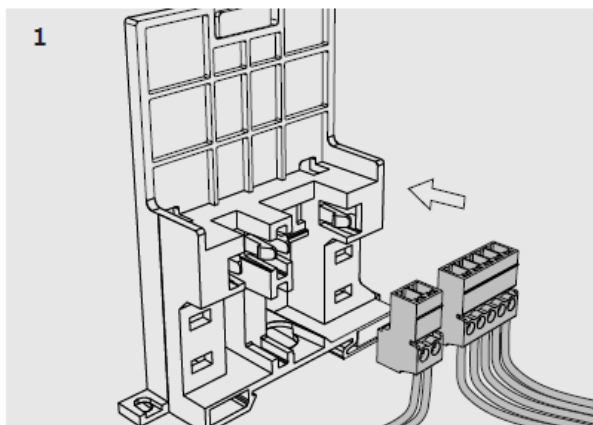

Caution!

Always make sure that the power supply is switched off before carrying out installation or maintenance on the Softstarter. Service and repair should be performed by authorized personnel only. Note that unauthorized repair affects safety and warranty

STATUS	SECURITY LEVEL	DOCUMENT ID.	REV.	LANG.	PAGE
Approved	Public	1SFC132068M0201	C	en	5/18

3. PSE Data

3.1. Digital input telegram

To PLC from the Softstarter.

To read the digital input telegram, use Modbus function code 1 Read Coil Status or 2 Read Discrete Inputs

Protocol address	Data	Description
0000h	Reserved	
0001h	Stop	0 = Motor running 1 = Motor stopped
0002h	Run	0 = Motor stopped 1 = Motor running
0003h	Reserved	
0004h	Reserved	
0005h	Auto mode ¹	0 = Local control 1 = Modbus master control
0006h	Fault	0 = No active fault 1 = One or more active faults
0007h	Reserved	
0008h	Reserved	
0009h	DI_FBP_Trip	0 = No trip on DI_FBP adaptor 1 = Trip on DI_FBP adaptor
000Ah	DI_FBP_Local	0 = Remote control 1 = Local control
000Bh	DI_Start	Hardwire DI Start input signal state 0 = DI Start signal inactive 1 = DI Start signal active
000Ch	DI_Stop	Hardwire DI Stop input signal state 0 = DI Stop signal inactive 1 = DI stop signal active
000Dh	DI_Reset	Hardwire DI Reset input signal state 0 = DI Reset signal inactive 1 = DI Reset signal active
000Eh	TOR	0 = Softstarter is not in top of ramp 1 = Softstarter is in top of ramp (bypass closed)
000Fh	Ready to start	0 = Fault is active or control supply voltage is not stable and motor will not start when start command is given 1 = No faults are active, control supply voltage is stable and motor will start when start command is given

¹)Auto mode reflects the control state of the Softstarter. This is affected by a combination of:

- The Auto mode input signal from the Modbus master (protocol address 0105h in the digital output telegram)
- The state of the Local/Remote switch on the Fieldbus Plug Accessory.

3.2. Digital output telegram

From PLC to the Softstarter.

To write the digital output telegram, use Modbus function code 5 Write Single Coil or 15 (0Fh) Force Multiple Coils.

To read the digital output telegram, use Modbus function code 1 Read Coil Status or 2 Read Input Status.

Protocol address	Data	Description
0100h	Reserved	
0101h	Stop	Commence a stop when this coil is set (this coil has higher priority than the start coil). The stop coil is only acknowledged if the Auto mode coil is set.
0102h	Start	Commence a start when this coil is set. The start coil is only acknowledged if the Auto mode coil is set.
0103h	Reserved	
0104h	Reserved	
0105h	Auto mode	This coil must be set for controlling the motor.
0106h	Fault reset	Reset an active fault or protection when this coil is set.
0107h	Reserved	
0108h	Reserved	
0109h	Reserved	
010Ah	Reserved	
010Bh	Reserved	
010Ch	Clear active diagnostics	Clear active diagnostics when this coil is set (register 2000h and 2003h will be cleared). See section 3.5.1
010Dh-011Fh	Reserved	

3.3. Analog input telegram

To PLC from the Softstarter.

All analog input telegram data values are represented as 16-bit values.

To read the analog input telegram, use Modbus function code 3 Read Holding Registers or 4 Read Input Registers.

Protocol Ad- dress	Data	Representation
0200h	Motor current in % of I _e (0%-800%)	Value = 1 ⇒ 1%
0201h	Thermal load in % of trip temperature (0%-100%)	Value = 1 ⇒ 1%

Protocol Address	Data	Representation
0202h	Phase current L1	Value = 1 ⇒ 1A
0203h	Phase current L2	Value = 1 ⇒ 1A
0204h	Phase current L3	Value = 1 ⇒ 1A
0205h	Max phase current	Value = 1 ⇒ 1A
0206h	Measured frequency	Value = 1 ⇒ 1Hz

3.4. Diagnostics

3.4.1. Diagnostic data

To PLC from the Softstarter.

To read the diagnostics data, use Modbus function code 3 Read Holding Registers or 4 Read Input Registers

Protocol Address	Bit	Data	Description
2000h	0	Reset possible on active event	Current fault or protection can be reset
	1	Software fault	Internal fault
	2	Shunt fault	Current is flowing when it should not
	3	By-pass open	By-pass does not close
	4	Softstarter overload	Too high thyristor- or heat sink temperature
	5	Phase loss	No voltage in one or more phases on the line side
	6	Bad network quality	Bad network quality on the line side
	7	Current loss	Current is not flowing when it should
	8	Fieldbus fault	Fieldbus communication failure
	9	Low supply voltage	Too low control supply voltage
	10	High current	Too high current
	11	Motor overload	Too high motor temperature
	12	Locked rotor protection	Current is higher than settable value during top of ramp
	13	Underload protection	Current is lower than settable value during top of ramp
	14	Reserved	
15	Reserved		
2001h	0..15	Reserved	
2002h	0..15	Reserved	
2003h	0	Reserved	
	1	Reserved	
	2	Reserved	
	3	Reserved	

Protocol Address	Bit	Data	Description
	4	Parameter is read-only	This bit is set if a parameter write operation failed due to the parameter being read-only.
	5	Parameter is not settable	This bit is set if a parameter write operation failed due to the parameter not being settable (such as during a soft start or soft stop).
	6	Parameter value is out of range	This bit is set if a parameter write parameter operation failed due to the set value being out of range.
	7	Extended diagnostic available	If set, fault code provides extended diagnostics.
	8..15	Fault code	This can be additional info for a fault such as in which phase the fault occurred or the parameter number of the latest read/write parameter operation failure.

The diagnostic data is composed of a bit map of all potential faults and protections, as well as a flag, which indicates if the active fault or protection can be reset. If “Parameter is read-only”, “Parameter not settable in current state” or “Parameter out of range” bits are set, “Fault code” contains the parameter number. “Parameter not settable in current state” can occur if the motor is running.

If “Extended diagnosis is available” is set, “Fault code” contains the Event information for the current event. For events that can occur on a specific line, e.g., Phase loss, the value of the fault code will indicate the line number the event occurred on. A “4” indicates the line cannot be determined or the problem exists on all three phases.

3.4.2. Modbus diagnostic data

To PLC from the Softstarter.

To read Modbus diagnostic data, use Modbus function code 3 Read Holding Registers or 4 Read Input Registers

Protocol Address	Words	Data	Description
4000h	2	Vendor name	Modbus Fieldbus plug device information
4002h	6	Product code	Modbus Fieldbus plug device information
4008h	2	Major Minor revision	Modbus Fieldbus plug device information
400Ah	6	Vendor URL	Modbus Fieldbus plug device information
4010h	8	Product Name	Modbus Fieldbus plug device information
4018h	8	Reserved	

Protocol Address	Words	Data	Description
4020h	8	Reserved	
4028h	7	Reserved	
402Fh	1	Modbus CRC-Error count	Number of Modbus CRC errors
4030h	1	Modbus Request Slave Exception Error Count	Number of slave exception errors
4031h	1	Modbus slave address	Slave id
4032h	1	Modbus baud rate	Unit is (baud rate / 100). E.g. 192 == 19200 baud

3.5. Parameters

Parameter registers begin at protocol address 3000h and consist of one register of one word for each parameter.

To write parameters, use Modbus function code 16 (10h) Preset Multiple Registers.

It is not supported to read parameters (all parameters are write only).

When programming parameters, high bytes shall come before low bytes. It is only possible to in a request write all parameters at the same time (single parameter write is not supported). See section 4.7 for an example.

Protocol Address	Type	Parameter Name	Representation	Default value
3000h	Write only	Motor rated current ¹	0 – 3700 = 0.0 – 370.0 [A]	Individual
3001h	Write only	Start ramp time	1 – 30 [s]	10
3002h	Write only	Stop ramp on	0 = Off, 1 = On	0
3003h	Write only	Stop ramp time	1 – 30 [s]	1
3004h	Write only	Initial voltage	30 – 70 [%]	40
3005h	Write only	End voltage	30 – 70 [%]	30
3006h	Write only	Current limit	15 – 70 = 1.5 – 7.0 [xIe]	70
3007h	Write only	Torque control start	0 = Off, 1 = On	0
3008h	Write only	Torque control stop	0 = Off, 1 = On	0
3009h	Write only	Kick start on	0 = Off, 1 = On	0
300Ah	Write only	Kick start time	1 – 10 = 0.1 – 1.0 [s]	2
300Bh	Write only	Kick start voltage	30 – 100 [%]	50
300Ch	Write only	EOL protection on	0 = Off, 1 = On	1
300Dh	Write only	EOL trip class	0 = 10A, 1 = 10, 2 = 20, 3 = 30	1
300Eh	Write only	EOL protection reset type	0 = Hand, 1 = Auto	0
300Fh	Write only	Underload protection on	0 = Off, 1 = On	0
3010h	Write only	Underload protection level	2 – 10 = 0.2 – 1.0 [xIe]	5
3011h	Write only	Underload protection reset type	0 = Hand, 1 = Auto	0
3012h	Write only	Locked rotor protection on	0 = Off, 1 = On	0

Protocol Address	Type	Parameter Name	Representation	Default value
3013h	Write only	Locked rotor protection level	5 – 70 = 0.5 – 7.0 [xle]	12
3014h	Write only	Locked rotor protection re-set type	0 = Hand, 1 = Auto	0
3015h	Write only	Bad network fault reset type	0 = Hand, 1 = Auto	0

¹⁾ A specific softstarter size in itself will have a much more narrow range defined by its rated current and only values within that range will be accepted.

3.5.1. Configure baud rate

Register at protocol address **4064h** contains the fieldbus baud rate parameter which can be both read and written.

To write this parameter, use Modbus function code 6 Write Single Register or 16 (10h) Preset Multiple Registers.

To read this parameter, use Modbus function code 3 Read Holding Registers or 4 Read Input Registers.

Response data or data to write is (baud rate / 100) and consists of two bytes.

Note that after changing the baud rate, communication with the slave will no longer work until the baud rate of the Modbus master has also been changed to the same value.

4. Modbus RTU – a set-up example

4.1. Softstarter PSE Fieldbus plug Modbus RTU communication

This document describes an example application with a Modbus RTU master (PLC CPU, PC, etc.) and the ABB PSE softstarter equipped with a Modbus fieldbus plug. In this example the softstarter address is 47 and it is valid for MRP21-FBP revision “e” and newer.

Please always use up-to-date softstarter and fieldbus plug manuals. In this particular example, the following documents have been used:

- Technical description Modbus-RTU FieldBusPlug MRP21-FBP, document 2CDC194001D0202PSE softstarter Installation and commissioning manual, document 1SFC132057M0201

4.2. Settings

1. Set the softstarter address and enable fieldbus communication:

Via the keypad, change the default address (255) of the softstarter with the keypad to 47 (FB Address) and enable the fieldbus communication (FB Enable = On). See PSE manual for details.

2. Set the communication parameters:

The communication parameters are: 1 Start bit, 8 Data bits, the Parity will be adapted to the master. The baud rate is mapped to the slave address, e.g., the baud rate corresponding to slave address 47 is 19200. Therefore the master and the slave will have the communication parameters: 1 start bit, 1 stop bit, 8 data bit, even parity, 19200 baud.

Note:

A configuration telegram is not necessary, so please do not send it.

Now the master can send different Modbus telegrams in order to exchange data with the softstarter. After receiving the first valid request from the Modbus master the H2 LED on the MRP21-FBP will stop blinking, confirming that the data exchange has started.

4.3. Read digital input telegram

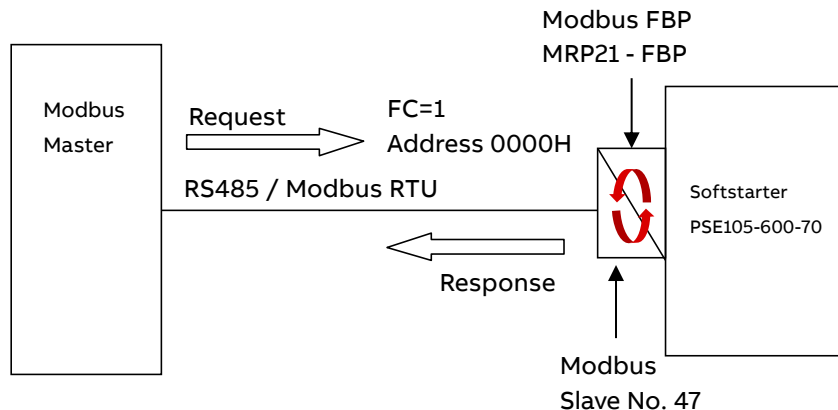

E.g: read 16 bits, starting at address 000H

Request:

2F	01	00	00	00	10	3B	88
Slave 47	FC 1	Address		16bit		CRC	

Response:

2F	01	02	00	00	51	FA
Slave 47	FC 1	2 Bytes	Byte 0	Byte 1	CRC	

4.4. Write digital output telegram

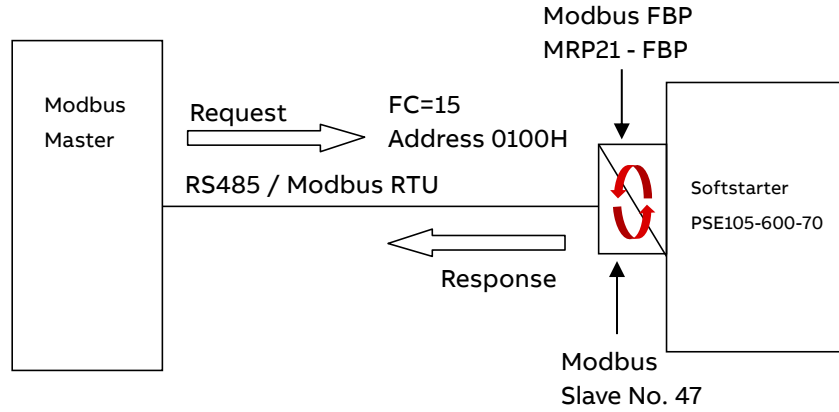

E.g: write 32 bits, starting at address 0100

Request:

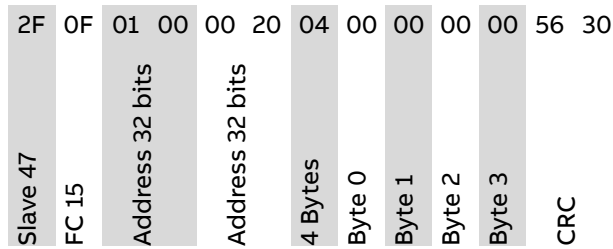

Response:

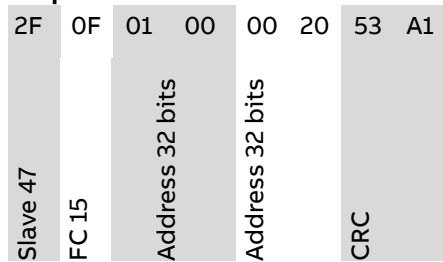

4.5. Read analog input telegram

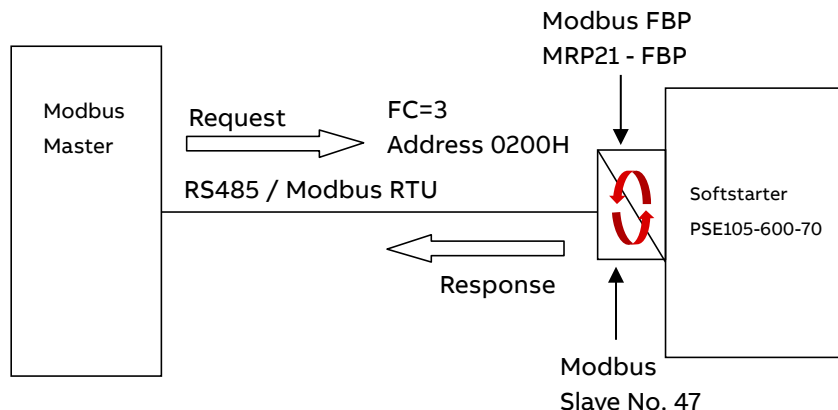

E.g: read 11 words, starting at address 0200H

Request:

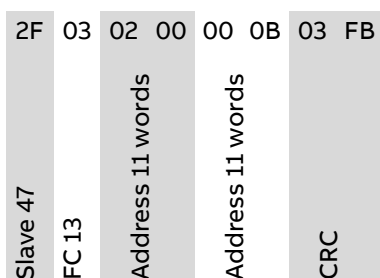

Response:

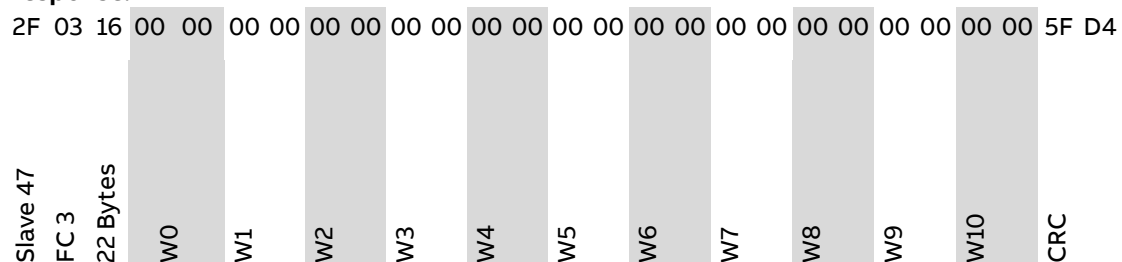

4.6. Read diagnostic inputs

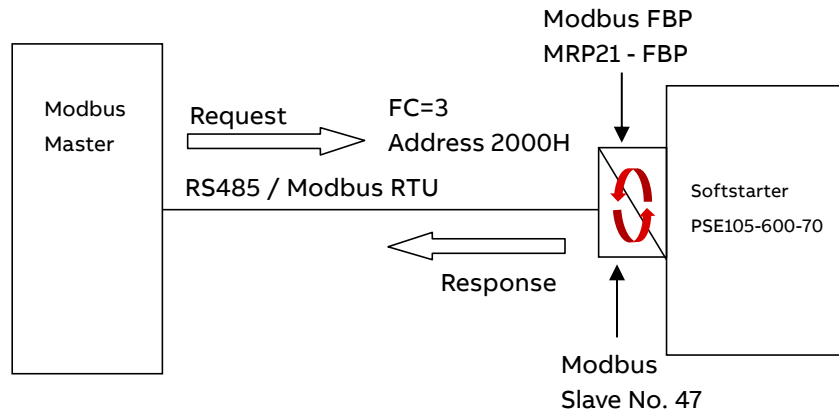

E.g: read 4 diagnostic words, starting at address 0200H

Request:

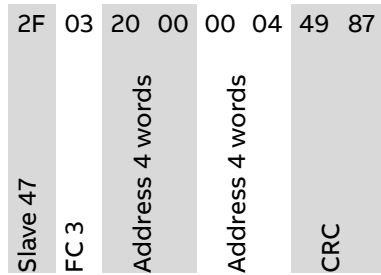

Response:

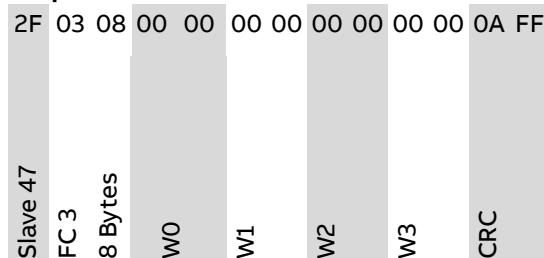

Word 0		Word 1		Word 2		Word 3	
HB	LB	HB	LB	HB	LB	HB	LB
Diagn. Byte 1	Diagn. Byte 0	Diagn. Byte 3	Diagn. Byte 2	Diagn. Byte 5	Diagn. Byte 4	Diagn. Byte 7	Diagn. Byte 6

HB: High byte, LB: Low byte

4.7. Write parameter data telegram

Note that only parameters with Type Write are transferred with this telegram.

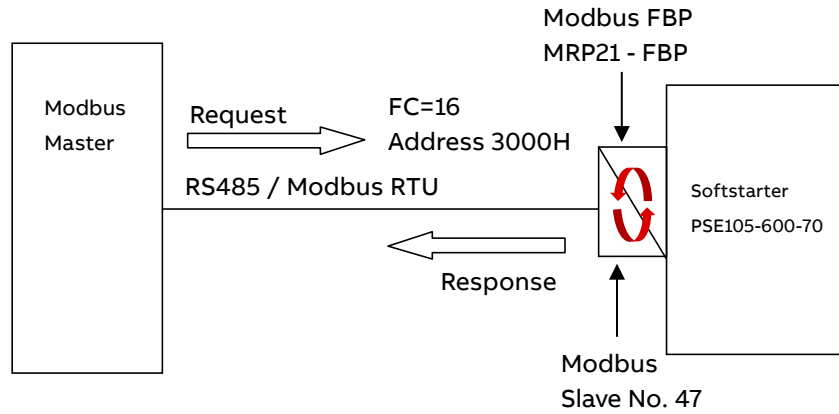

E.g: Write 22 words, starting at address 3000H

Request:

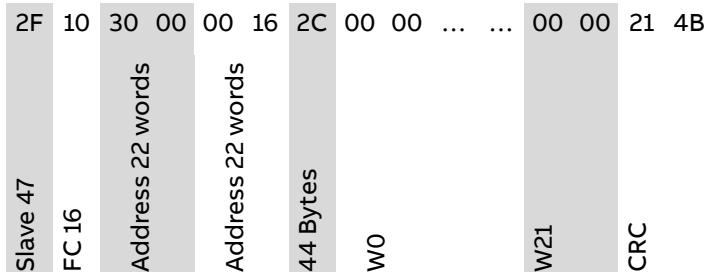

W0: Setting le

...

W13: EOL Class

...

W21: BadNet Op

Response:

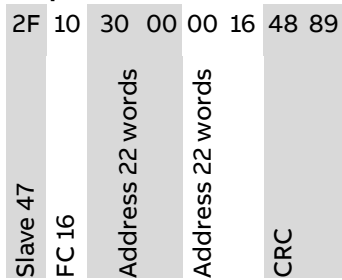

5. Troubleshooting

5.1. Modbus slave does not respond to requests

RS485

- Are the termination resistors placed at the end of the line?
- Only 2 termination resistors in one segment?
- Are 2 termination resistors placed at each bus segment?
- Are bias resistors connected in each bus segment?
- Is the line polarity correct? Are the lines by accident swapped?
- Never place any termination resistors on a drop cable.
- Is the maximum line length exceeded?

Modbus Parameters

- Check that fieldbus interface type parameter is set to Internal Modbus-RTU (INT on display).
- Check that you are using the correct Modbus address, baud rate and frame format.
- Note that the slave will not respond to broadcasts (requests to address 0), only act upon them.

Modbus slave

- Has the device a unique Modbus address?
- Is the function code supported by the device?
- Has the request a valid address?
- Has the request a valid quantity of coils, inputs, registers?
- Is the power supply turned on?

Modbus master

- Is the Modbus master in RTU mode?
- Is the request to response timeout correct?
- Is the Modbus silent interval between two telegrams > 3.5 character times?
- Notice that the slave device will not give any response when it is addressed with a broadcast (slave address = 0).
- Check if PLC is in run mode.

STATUS	SECURITY LEVEL	DOCUMENT ID.	REV.	LANG.	PAGE
Approved	Public	1SFC132068M0201	C	en	17/18

5.2. PSE trips on fieldbus fault (EF40)

- The purpose of the fieldbus fault function is to detect any communication problems between the Modbus master and the Softstarter. Fieldbus fault will be enabled if the Fieldbus control parameter is set to On and Operation when fault parameter is set to triP.
- When fieldbus fault reaction is set to trip, the Softstarter will trip on Fieldbus Fault (EF40) after a set time of no communication. This timeout parameter value is fixed to 0,3s and cannot be changed.
- If there has been a trip on fieldbus fault for some reason, the communication has to afterwards be continuously stable for 10s before the Softstarter accepts commands from the Modbus master and when it is possible to reset the fault.

5.3. Motor does not start

- If fieldbus fault reaction is set to “switch to local control” and fieldbus communication is lost and/or timeout is reached, the Softstarter can only be controlled with hard-wire signals. When communication is re-established, there is a 10 second delay before fieldbus control is possible.
- Check if the fieldbus control parameter is set to ON.
- Make sure the auto mode is enabled in order to control the motor with Modbus. The data value in protocol address 0105h shall be set.
- Check if the stop coil is set since it has higher priority than the start coil.
- Motor will not start if there is an active fault (check the ready to start coil).

5.4. Parameter write does not work

- Check if the parameter download parameter is enabled (set to dPon).
- Check if the parameter is read-only or if the value to be written is out of range.
- Check if the value to be written is correctly scaled (see the representation column in section 3.6).
- When programming parameters, high bytes shall come before low bytes and it is only possible to in a request write all parameters at the same time (single parameter write is not supported). Parameter write operation will not work during a soft start or soft stop. It will only work in the standby state and top of ramp state.
- Check bits 4-15 in protocol address 2003h for diagnostic information related to the latest parameter write operation failure (see section 3.5.1).

6. Contact us

For more information, please contact your local ABB representative or visit <https://new.abb.com/low-voltage/products/softstarters-new>

STATUS	SECURITY LEVEL	DOCUMENT ID.	REV.	LANG.	PAGE
Approved	Public	1SFC132068M0201	C	en	18/18