

ROBOTICS

# Product specification

## IRB 7600

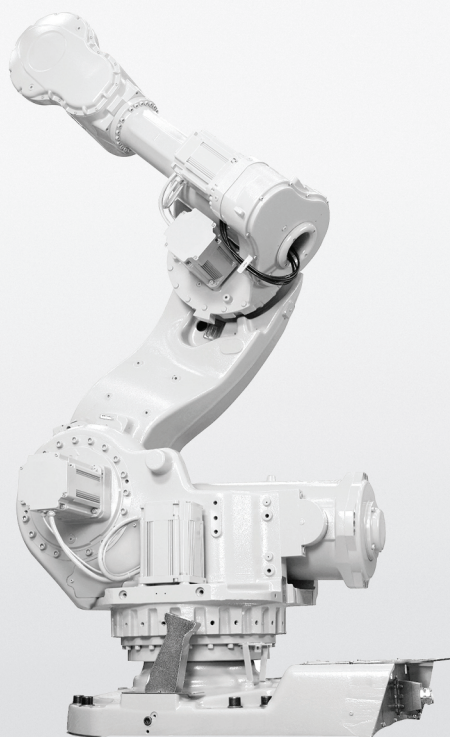

Trace back information:  
Workspace 24D version a3  
Checked in 2024-12-05  
Skribenta version 5.6.018

## **Product specification**

**IRB 7600-500/2.55**

**IRB 7600-400/2.55**

**IRB 7600-340/2.8**

**IRB 7600-325/3.1**

**IRB 7600-150/3.5**

**OmniCore**

**Document ID: 3HAC087209-001**

**Revision: E**

The information in this manual is subject to change without notice and should not be construed as a commitment by ABB. ABB assumes no responsibility for any errors that may appear in this manual.

Except as may be expressly stated anywhere in this manual, nothing herein shall be construed as any kind of guarantee or warranty by ABB for losses, damage to persons or property, fitness for a specific purpose or the like.

In no event shall ABB be liable for incidental or consequential damages arising from use of this manual and products described herein.

This manual and parts thereof must not be reproduced or copied without ABB's written permission.

Keep for future reference.

Additional copies of this manual may be obtained from ABB.

Original instructions.

© Copyright 2004-2024 ABB. All rights reserved.  
Specifications subject to change without notice.

# Table of contents

Overview of this product specification .....	7
<b>1 Description</b>	<b>9</b>
1.1 Structure .....	9
1.1.1 Introduction .....	9
1.1.2 Robot variants .....	12
1.1.3 Technical data .....	13
1.2 Standards .....	16
1.2.1 Applicable standards .....	16
1.3 Installation .....	17
1.3.1 Introduction .....	17
1.3.2 Technical data .....	18
1.3.3 Mounting the manipulator .....	22
1.4 Calibration and references .....	27
1.4.1 Calibration methods .....	27
1.4.2 Fine calibration .....	29
1.4.3 Absolute Accuracy calibration .....	30
1.4.4 Robot reference .....	32
1.5 Load diagrams .....	34
1.5.1 Introduction .....	34
1.5.2 Load diagrams .....	36
1.5.3 Max. load and moment of inertia for full and limited axis 5 (center down line) movement .....	49
1.5.4 Wrist torque .....	51
1.5.5 Mounting equipment .....	52
1.5.6 Mounting of hip load .....	54
1.5.7 Maximum TCP acceleration .....	57
1.6 Maintenance and troubleshooting .....	58
1.6.1 Introduction .....	58
1.7 Robot motion .....	59
1.7.1 Introduction .....	59
1.7.2 Performance according to ISO 9283 .....	62
1.7.3 Velocity .....	63
1.7.4 Robot stopping distances and times .....	64
<b>2 DressPack</b>	<b>65</b>
2.1 General .....	65
2.1.1 Introduction .....	65
2.1.2 Product range .....	67
2.1.3 Limitations of robot movements .....	68
2.1.4 Impact on DressPack lifetime .....	69
2.2 DressPack .....	70
2.2.1 Introduction .....	70
2.2.2 Built-in features for upper arm DressPack .....	71
2.2.3 Interface descriptions for DressPack .....	72
2.2.4 Dimensions .....	77
2.3 Connector kits .....	79
<b>3 Specification of variants and options</b>	<b>81</b>
3.1 Introduction to variants and options .....	81
3.2 Manipulator .....	82
3.3 Floor cables .....	88
3.4 Application manipulator .....	89
3.5 Connector kits manipulator .....	91
3.5.1 Base - Connector kits .....	92
3.5.2 Axis 3 - Connector kits .....	94

## Table of contents

---

3.5.3	Axis 6 - Connector kits .....	95
3.6	Application floor cables .....	97
3.7	Warranty .....	99
<b>Index</b>		<b>101</b>

---

# Overview of this product specification

## About this product specification

It describes the performance of the manipulator or a complete family of manipulators in terms of:

- The structure and dimensional prints
- The fulfilment of standards, safety and operating requirements
- The load diagrams, mounting of extra equipment, the motion and the robot reach
- The specification of variant and options available

## Usage

Product specifications are used to find data and performance about the product, for example to decide which product to buy. How to handle the product is described in the product manual.

## Users

It is intended for:

- Product managers and Product personnel
- Sales and Marketing personnel
- Order and Customer Service personnel

## References

Reference	Document ID
<i>Product specification - OmniCore V line</i>	3HAC074671-001
<i>Product manual - IRB 7600</i>	3HAC022033-001
<i>Product manual - DressPack IRB 7600</i>	3HAC056372-001

## Revisions

Revision	Description
A	First edition.
B	Published in release 24A. The following updates are done in this revision: <ul style="list-style-type: none"> <li>• Added DressPack options for CC-Link.</li> </ul>
C	Published in release 24B. The following updates are done in this revision: <ul style="list-style-type: none"> <li>• Added options for motor cooling.</li> <li>• Added DressPack options for EtherCAT.</li> </ul>
D	Published in release 24C. The following updates are done in this revision: <ul style="list-style-type: none"> <li>• Added 22 m process cables.</li> </ul>
E	Published in release 24D. The following updates are done in this revision: <ul style="list-style-type: none"> <li>• Updated the section <a href="#">Technical data on page 18</a>.</li> </ul>

**This page is intentionally left blank**

# 1 Description

## 1.1 Structure

### 1.1.1 Introduction

---

#### General

The IRB 7600 is available in five variants, with 500 kg, 400 kg, 340 kg, 325 kg, and 150 kg handling capacity.

The IRB 7600 is ideal for heavy-weight applications, regardless of industry. Typical areas can be handling of heavy fixtures, turning car bodies, lifting engines, handling heavy parts, loading and unloading of machine cells, alternatively handling large and heavy pallet layers.

---

#### Software product range

We have added a range of software products - all falling under the umbrella designation of Active Safety - to protect not only personnel in the unlikely event of an accident, but also robot tools, peripheral equipment and the robot itself.

---

#### Process Options

There are a large number of process options for Spot Welding and Material Handling integrated in the robot.

---

#### Operating system

The robot is equipped with the OmniCore controller and robot control software, RobotWare. RobotWare supports every aspect of the robot system, such as motion control, development and execution of application programs, communication etc. See *Product specification - OmniCore V line*.

The IRB 7600 manipulator can be connected to the following robot controllers:

- OmniCore V250XT
  - OmniCore V400XT
- 

#### Safety

Safety standards valid for complete robot, manipulator and controller.

---

#### Additional functionality

For additional functionality, the robot can be equipped with optional software for application support - for example gluing and welding, communication features - network communication - and advanced functions such as multitasking, sensor control etc. For a complete description on optional software, see *Product specification - OmniCore V line*.

---

*Continues on next page*

# 1 Description

---

## 1.1.1 Introduction

*Continued*

---

### Protection type Foundry Plus 2

Robots with the option Foundry Plus 2 are designed for harsh environments where the robot is exposed to sprays of coolants, lubricants and metal spits that are typical for die casting applications or other similar applications.

Typical applications are spraying insertion and part extraction of die-casting machines, handling in sand casting and gravity casting, etc. (Please refer to Foundry Prime robots for washing applications or other similar applications). Special care must be taken in regard to operational and maintenance requirements for applications in foundry as well as in other applications areas. Please contact ABB Robotics Sales organization if in doubt regarding specific application feasibility for the Foundry Plus 2 protected robot.

The robot is painted with two-component epoxy on top of a primer for corrosion protection. To further improve the corrosion protection additional rust preventive are applied to exposed and crucial areas, e.g. has the tool flange a special preventive coating. Although, continuous splashing of water or other similar rust formation fluids may cause rust attach on the robots unpainted areas, joints, or other unprotected surfaces. Under these circumstances it is recommended to add rust inhibitor to the fluid or take other measures to prevent potential rust formation on the mentioned.

The entire robot is IP67 compliant according to IEC 60529 - from base to wrist, which means that the electrical compartments are sealed against water and solid contaminants. Among other things all sensitive parts are better protected than the standard offer.

Selected Foundry Plus 2 features:

- Improved sealing to prevent penetration into cavities to secure IP67
- Additional protection of cabling and electronics
- Special covers that protect cavities
- Well-proven connectors
- Nickel coated tool flange
- Rust preventives on screws, washers and unpainted/machined surfaces
- Extended service and maintenance program

The Foundry Plus 2 robot can be cleaned with appropriate washing equipment according to the robot product manual. Appropriate cleaning and maintenance is required to maintain the protection, for example can rust preventive be washed off with wrong cleaning method.

### Available robot variants

The option Foundry Plus 2 might not be available for all robot variants.

See [Specification of variants and options on page 81](#) for robot versions and other options not selectable together with Foundry Plus 2.

*Continues on next page*

Axis movement

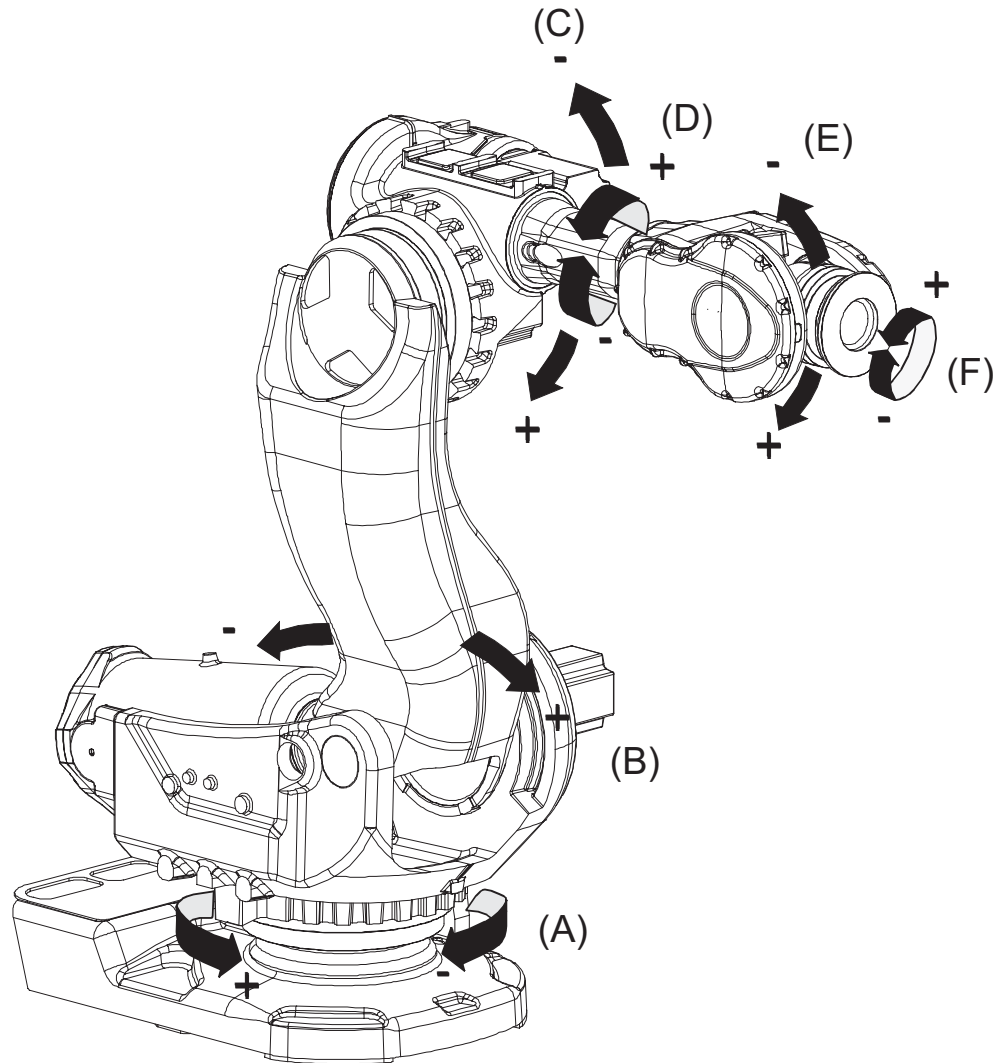

xx100000563

Pos	Description	Pos	Description
A	Axis 1	D	Axis 4
B	Axis 2	E	Axis 5
C	Axis 3	F	Axis 6

# 1 Description

---

## 1.1.2 Robot variants

### 1.1.2 Robot variants

---

#### Robot variants

The following standard robot variants are available.

Robot type	Handling capacity	Handling capacity for LeanID	Reach
IRB 7600	500 kg	-	2.55 m
IRB 7600	400 kg	390 kg	2.55 m
IRB 7600	340 kg	320 kg	2.8 m
IRB 7600	325 kg	290 kg	3.1 m
IRB 7600	150 kg	-	3.5 m



#### Note

For LeanID options, the payload will decrease as stated above. For detailed information, see [Load diagrams on page 34](#).

1.1.3 Technical data

Manipulator weight

Manipulator	Weight (kg) <sup>i</sup>
IRB 7600 - 500/2.55	2400
IRB 7600 - 400/2.55	2400
IRB 7600 - 340/2.8	2425
IRB 7600 - 325/3.1	2440
IRB 7600 - 150/3.5	2450

<sup>i</sup> Without DressPack.

Power consumption at max load

Type of movement	Power consumption at maximum load (kW)
ISO Cube	3.1
Normal robot movements	4.5

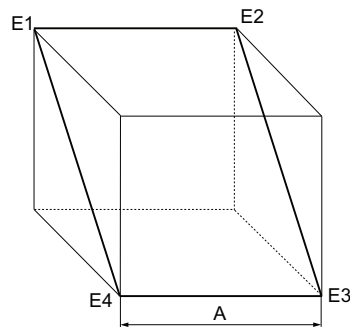

xx1000000101

Pos	Description
A	1,000 mm

Power factor (cos φ)

The power factor is above 0.95 at a steady state power consumption higher than 2.0 kW, when the IRB 7600 is connected to the OmniCore V line.

Airborne noise level

Data	Description	Note
Airborne noise level	The sound pressure level outside the working space	73 dB (A) Leq (acc. to Machinery directive 2006/42/EG).

Continues on next page

# 1 Description

## 1.1.3 Technical data

Continued

### IRB 7600 - 400/2.55 and IRB 7600 - 500/2.55

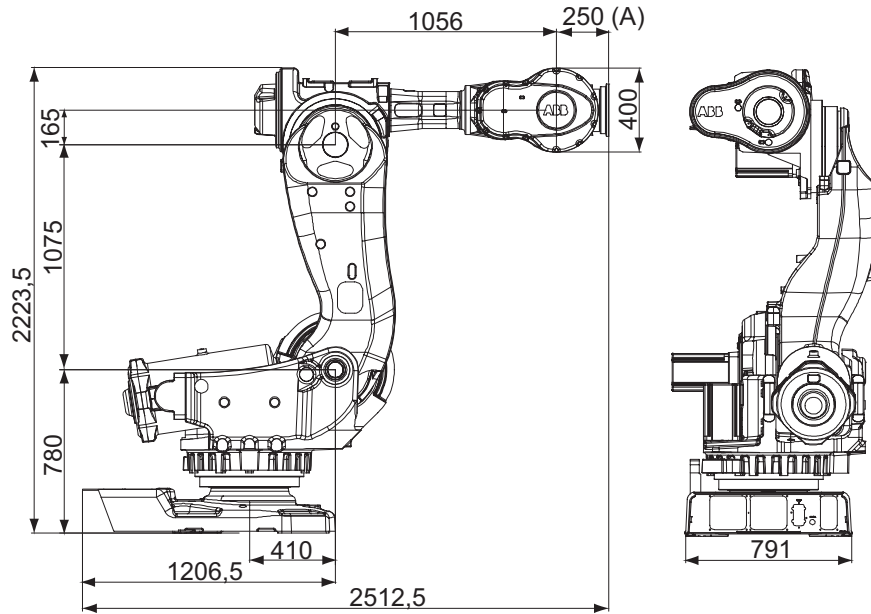

xx1000000564

A	IRB 7600-400/2.55, 404 mm for LeanID
---	--------------------------------------

### IRB 7600 - 340/2.8

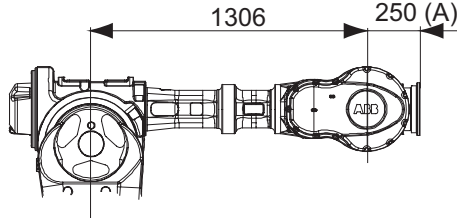

xx1000000565

A	404 mm for LeanID
---	-------------------

### IRB 7600 - 325/3.1

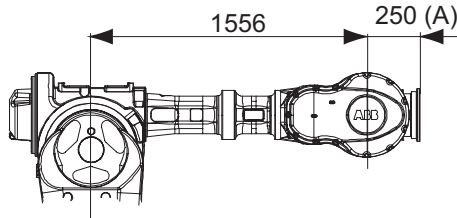

xx1000000567

A	404 mm for LeanID
---	-------------------

Continues on next page

IRB 7600 - 150/3.5

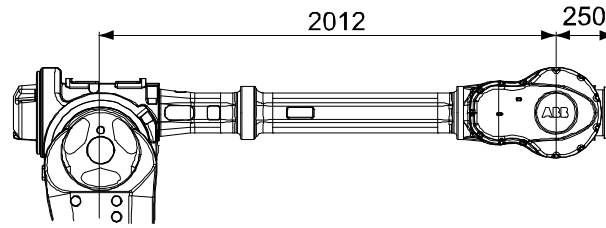

xx1000000566

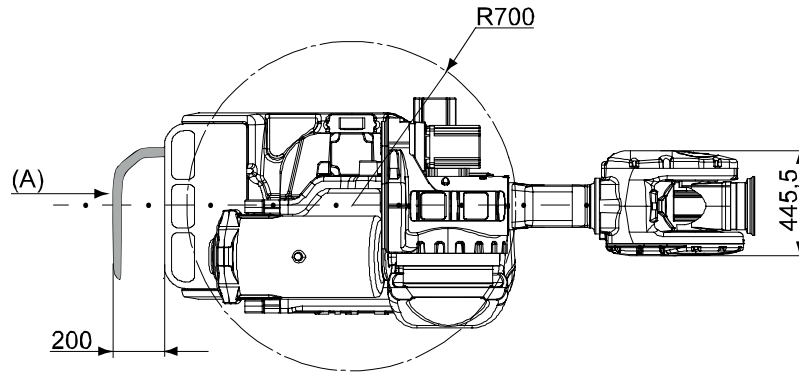

xx1000000607

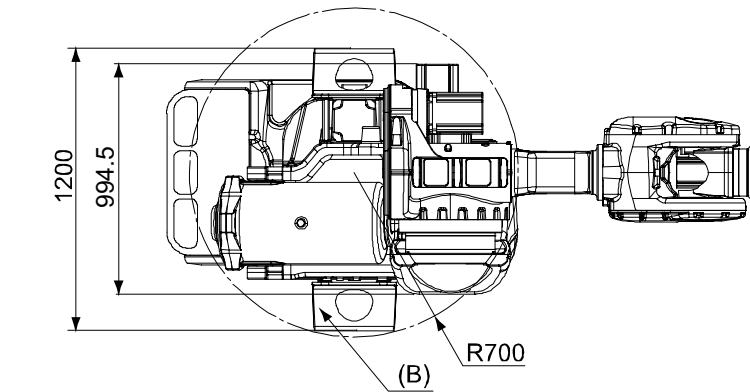

Pos	Description
A	Robot power cable
B	Fork lift device

# 1 Description

---

## 1.2.1 Applicable standards

## 1.2 Standards

### 1.2.1 Applicable standards

---

#### General

The product is compliant with ISO 10218-1:2011, *Robots for industrial environments - Safety requirements - Part 1 Robots*, and applicable parts in the normative references, as referred to from ISO 10218-1:2011. In case of deviation from ISO 10218-1:2011, these are listed in the declaration of incorporation. The declaration of incorporation is part of the delivery.

---

#### Robot standards

Standard	Description
ISO 9283	Manipulating industrial robots – Performance criteria and related test methods
ISO 9787	Robots and robotic devices – Coordinate systems and motion nomenclatures
ISO 9946	Manipulating industrial robots – Presentation of characteristics

---

#### Other standards used in design

Standard	Description
IEC 60204-1	Safety of machinery - Electrical equipment of machines - Part 1: General requirements, normative reference from ISO 10218-1
IEC 61000-6-2	Electromagnetic compatibility (EMC) – Part 6-2: Generic standards – Immunity standard for industrial environments
IEC 61000-6-4	Electromagnetic compatibility (EMC) – Part 6-4: Generic standards – Emission standard for industrial environments
ISO 13849-1:2006	Safety of machinery - Safety related parts of control systems - Part 1: General principles for design, normative reference from ISO 10218-1
UL 1740 (option) CSA Z434 (option)	Standards For Safety - Robots and Robotic Equipment Industrial robots and robot Systems - General safety requirements Valid for USA and Canada.

## 1.3 Installation

### 1.3.1 Introduction

---

#### General

All versions of IRB 7600 are designed for floor mounting (no tilting allowed around X-axis or Y-axis). Depending on the robot version, an end effector with max. weight of 150 to 500 kg including payload, can be mounted on the mounting flange (axis 6). See [Load diagrams on page 34](#) for IRB 7600 generation robots.

#### Extra loads

Extra loads (valve packages, transformers) can be mounted on the upper arm with a maximum weight of 50 kg. On all versions an extra load of 500 kg can also be mounted on the frame of axis 1. For more information see [Mounting equipment on page 52](#).

#### Working range

The working range of axes 1-3 can be limited by mechanical stops.

#### Explosive environments

The robot must not be located or operated in an explosive environment.

# 1 Description

## 1.3.2 Technical data

### 1.3.2 Technical data

#### Weight, robot

The table shows the weight of the robot.

The weight does not include the weight of the DressPack.

Robot model	Weight
IRB 7600	2500 kg



#### Note

The weight does not include tools and other equipment fitted on the robot.  
The weight does not include the weight of the DressPack.

#### Mounting positions

The table shows valid mounting options for the manipulator.

Mounting option	Installation angle	Note
Floor mounted	0° <sup>i</sup>	

<sup>i</sup> A tilt of up to 5° does not affect the payload or reach, but it can have a negative impact on performance and lifetime. The actual value must be set in the system parameters.



#### Note

The actual mounting angle must always be configured in the system parameters, otherwise the performance and lifetime is affected. See the product manual for details.

*Continues on next page*

### Loads on foundation, robot

The illustration shows the directions of the robots stress forces.

The directions are valid for all floor mounted, suspended and inverted robots.

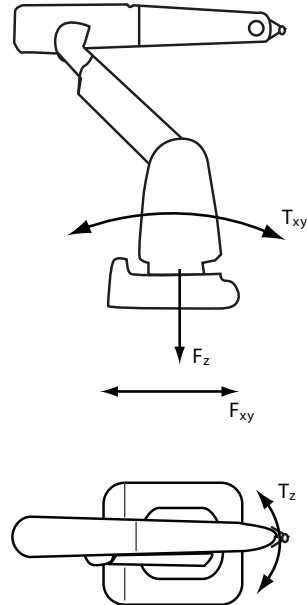

xx1100000521

$F_{xy}$	Force in any direction in the XY plane
$F_z$	Force in the Z plane
$T_{xy}$	Bending torque in any direction in the XY plane
$T_z$	Bending torque in the Z plane

The table shows the various forces and torques working on the robot during different kinds of operation.



#### Note

These forces and torques are extreme values that are rarely encountered during operation. The values also never reach their maximum at the same time!



#### WARNING

The robot installation is restricted to the mounting options given in following load table(s).

### Floor mounted

Force	Endurance load (in operation)	Max. load (emergency stop)
Force xy	$\pm 14$ kN	$\pm 31$ kN
Force z	$+32 \pm 10$ kN	$+39 \pm 16$ kN
Torque xy	$\pm 42$ kNm	$\pm 72$ kNm
Torque z	$\pm 11$ kNm	$\pm 19.5$ kNm

*Continues on next page*

# 1 Description

## 1.3.2 Technical data

Continued

### Requirements, foundation

The table shows the requirements for the foundation where the weight of the installed robot is included:

Requirement	Value	Note
Flatness of foundation surface	0.3 mm	Flat foundations give better repeatability of the resolver calibration compared to original settings on delivery from ABB. The value for levelness aims at the circumstance of the anchoring points in the robot base. In order to compensate for an uneven surface, the robot can be recalibrated during installation. If resolver/encoder calibration is changed this will influence the absolute accuracy.
Minimum resonance frequency	22 Hz  <b>Note</b> It may affect the manipulator lifetime to have a lower resonance frequency than recommended.	The value is recommended for optimal performance. Due to foundation stiffness, consider robot mass including equipment. <sup>i</sup> For information about compensating for foundation flexibility, see the application manual of the controller software, section <i>Motion Process Mode</i> .

- <sup>i</sup> The minimum resonance frequency given should be interpreted as the frequency of the robot mass/inertia, robot assumed stiff, when a foundation translational/torsional elasticity is added, i.e., the stiffness of the pedestal where the robot is mounted. The minimum resonance frequency should not be interpreted as the resonance frequency of the building, floor etc. For example, if the equivalent mass of the floor is very high, it will not affect robot movement, even if the frequency is well below the stated frequency. The robot should be mounted as rigid as possible to the floor.  
Disturbances from other machinery will affect the robot and the tool accuracy. The robot has resonance frequencies in the region 10 – 20 Hz and disturbances in this region will be amplified, although somewhat damped by the servo control. This might be a problem, depending on the requirements from the applications. If this is a problem, the robot needs to be isolated from the environment.

### Storage conditions, robot

The table shows the allowed storage conditions for the robot:

Parameter	Value
Minimum ambient temperature	-25° C
Maximum ambient temperature	+55° C
Maximum ambient temperature (less than 24 hrs)	+70° C
Maximum ambient humidity	95% at constant temperature (gaseous only)

### Operating conditions, robot

The table shows the allowed operating conditions for the robot:

Parameter	Value
Minimum ambient temperature	+5° C
Maximum ambient temperature	+50° C
Maximum ambient humidity	Max. 95% at constant temperature

Continues on next page

### Protection classes, robot

The table shows the available protection types of the robot, with the corresponding protection class.

Protection type	Protection class <sup>i</sup>
Manipulator, protection type Standard	IP 67
Manipulator, protection type Foundry Plus	IP 67

<sup>i</sup> According to IEC 60529.

# 1 Description

## 1.3.3 Mounting the manipulator

### 1.3.3 Mounting the manipulator

#### General

Maximum load in relation to the base coordinate system.

#### Floor Mounted

Force	Endurance load (in operation)	Max. load (emergency stop)
Force xy	$\pm 14$ kN	$\pm 31$ kN
Force z	$+32 \pm 10$ kN	$+39 \pm 16$ kN
Torque xy	$\pm 42$ kNm	$\pm 72$ kNm
Torque z	$\pm 11$ kNm	$\pm 19.5$ kNm

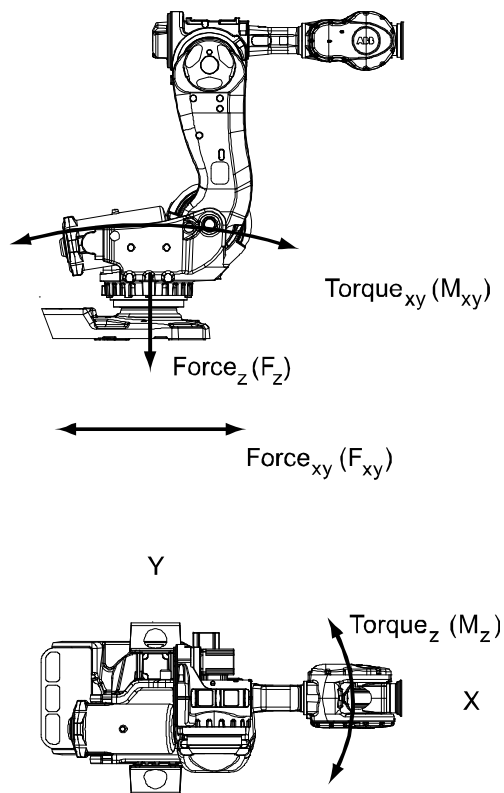

xx1000000568

#### Note regarding $M_{xy}$ and $F_{xy}$

The bending torque ( $M_{xy}$ ) can occur in any direction in the XY-plane of the base coordinate system.

The same applies to the transverse force ( $F_{xy}$ ).

*Continues on next page*

Fastening holes robot base

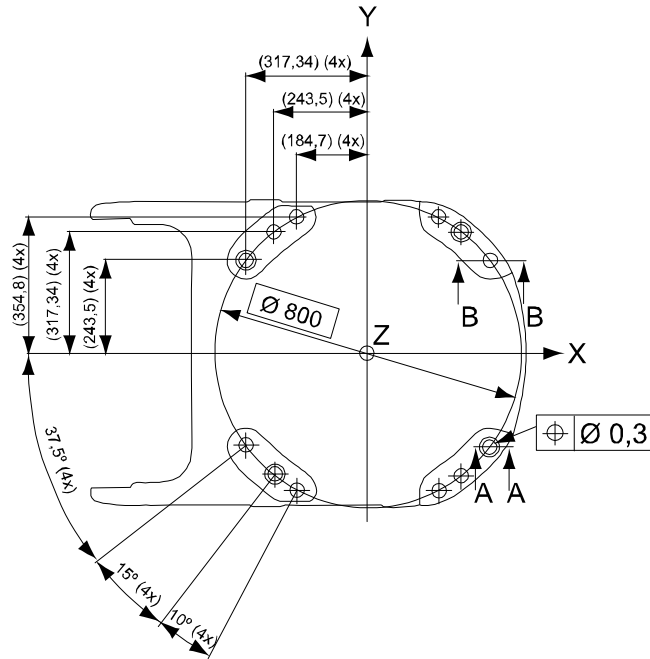

xx1000000569

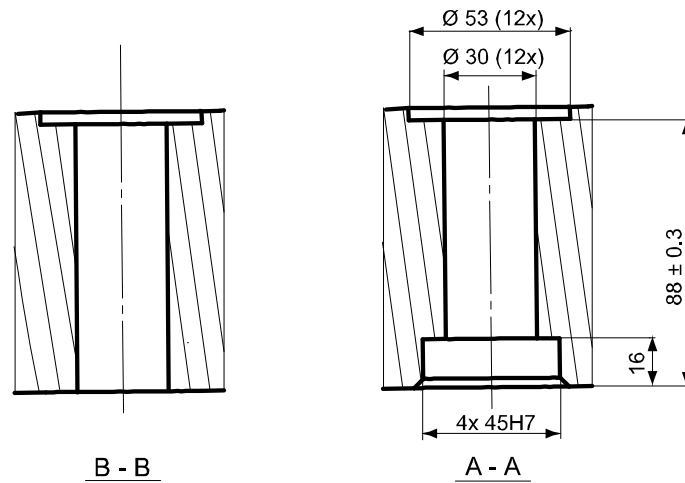

xx1000000570

Recommended screws for fastening the manipulator to the base	M24 x 140 8.8 with 4 mm flat washer.
Torque value	725 Nm

Two guiding sleeves required, dimension see Figures in this chapter.



Note

Only two guiding sleeves shall be used. The corresponding holes in the base plate shall be circular and oval according to next two Figures below. Regarding AbsAcc performance, the chosen guide holes are to be recommended according to next two Figures below.

Continues on next page

# 1 Description

## 1.3.3 Mounting the manipulator

Continued

### Base plate drawing

The following figure shows the option base plate (dimensions in mm).

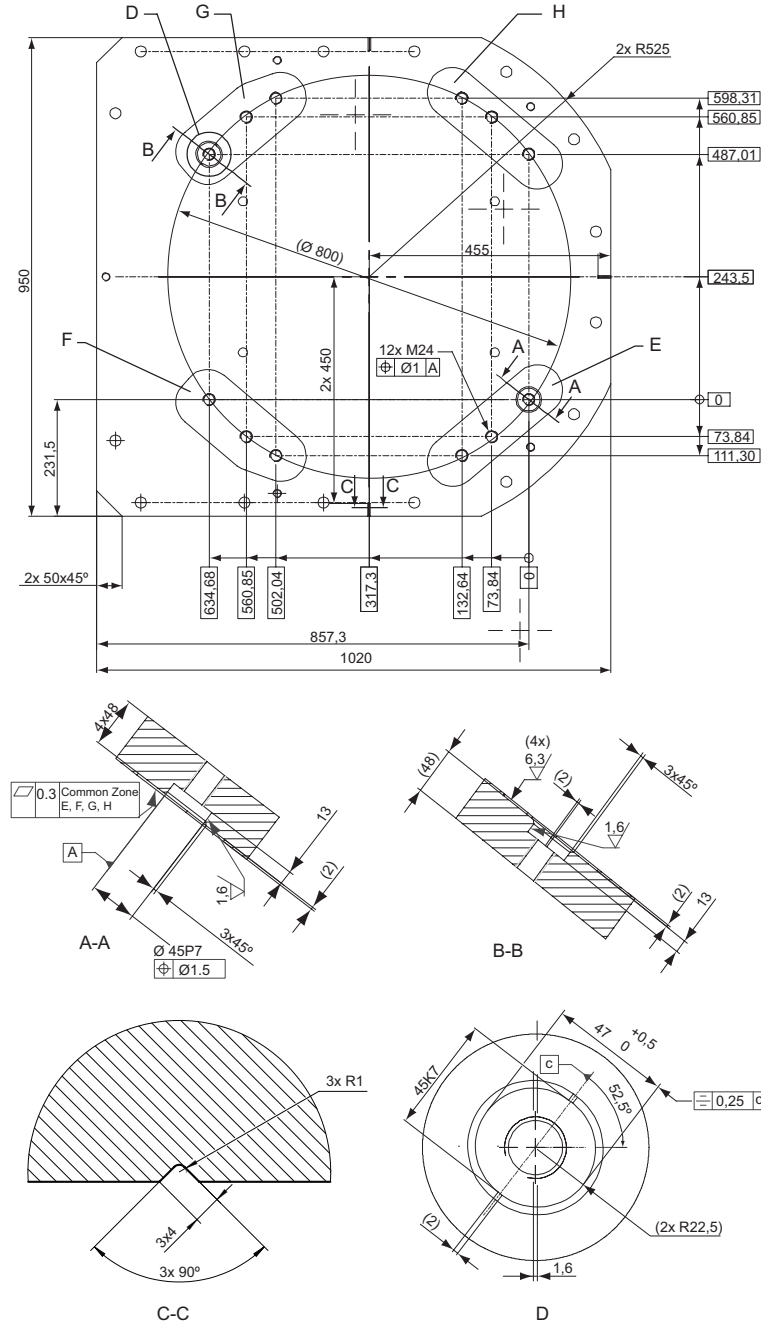

xx1000001053

E, F, G, H	Common tolerance zone (accuracy all over the base plate from one contact surface to the other)
------------	--

Continues on next page

# 1 Description

## 1.3.3 Mounting the manipulator

Continued

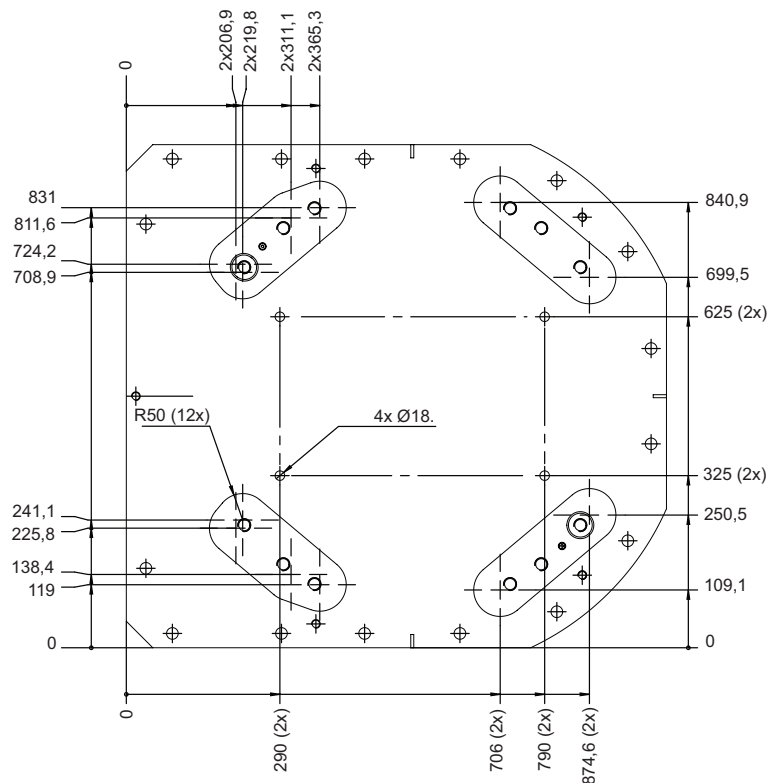
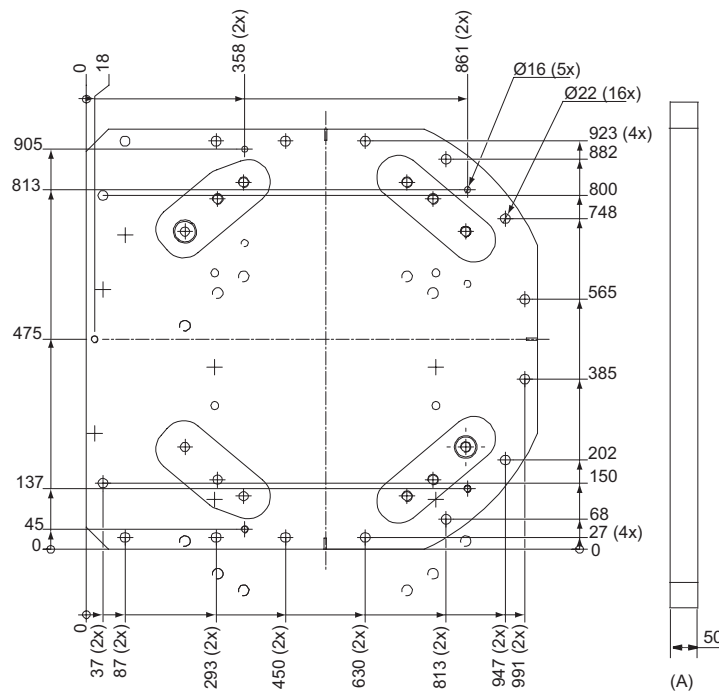

xx1000001054

Pos	Description
A	Color: RAL 9005 Thickness: 80-100 $\mu\text{m}$

Continues on next page

# 1 Description

## 1.3.3 Mounting the manipulator

Continued

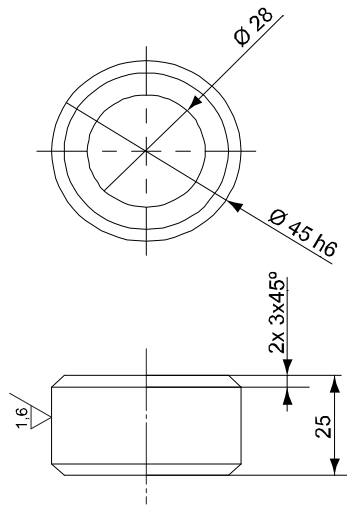

xx1000001055

Pos	Description
A	Guide sleeve protected from corrosion

### Fastener quality

When fitting tools on the tool flange, only use screws with quality 12.9. For other equipment use suitable screws and tightening torque for your application.

## 1.4 Calibration and references

### 1.4.1 Calibration methods

#### Overview

This section specifies the different types of calibration and the calibration methods that are supplied by ABB.

More information is available in the product manual.

#### Types of calibration

Type of calibration	Description	Calibration method
Standard calibration	The calibrated robot is positioned at calibration position. Standard calibration data is found on the SMB (serial measurement board) or EIB in the robot.	Axis Calibration or Calibration Pendulum <sup>i</sup> Levelmeter calibration (alternative method)
Absolute accuracy calibration (optional)	Based on standard calibration, and besides positioning the robot at synchronization position, the Absolute accuracy calibration also compensates for: <ul style="list-style-type: none"> <li>Mechanical tolerances in the robot structure</li> <li>Deflection due to load</li> </ul> <p>Absolute accuracy calibration focuses on positioning accuracy in the Cartesian coordinate system for the robot.</p> <p>Absolute accuracy calibration data is found on the serial measurement board (SMB) or other robot memory.</p> <p>A robot calibrated with Absolute accuracy has the option information printed on its name plate (OmniCore).</p> <p>To regain 100% Absolute accuracy performance, the robot must be recalibrated for absolute accuracy after repair or maintenance that affects the mechanical structure.</p>	CalibWare
Optimization	Optimization of TCP reorientation performance. The purpose is to improve reorientation accuracy for continuous processes like welding and gluing. Wrist optimization will update standard calibration data for axes 4 and 5.   <b>Note</b> For advanced users, it is also possible to use the do the wrist optimization using the RAPID instruction <code>WristOpt</code> , see <i>Technical reference manual - RAPID Instructions, Functions and Data types</i> . This instruction is only available for OmniCore robots.	Wrist Optimization

<sup>i</sup> The robot is calibrated by either Calibration Pendulum or Axis Calibration at factory. Always use the same calibration method as used at the factory.

Continues on next page

# 1 Description

---

## 1.4.1 Calibration methods

*Continued*

Information about valid calibration method is found on the calibration label or in the calibration menu on the FlexPendant.

If no data is found related to standard calibration, contact the local ABB Service.

---

### Brief description of calibration methods

#### Calibration Pendulum method

Calibration Pendulum is a standard calibration method for calibration of some ABB robots. On OmniCore, this calibration method is only used on IRB 1510, IRB 1520, IRB 2400, and IRB 4400.

Two different routines are available for the Calibration Pendulum method:

- Calibration Pendulum II
- Reference calibration

The calibration equipment for Calibration Pendulum is delivered as a complete toolkit, including the *Operating manual - Calibration Pendulum*, which describes the method and the different routines further.

#### Axis Calibration method

Axis Calibration is a standard calibration method for calibration of IRB 7600. It is the recommended method in order to achieve proper performance.

The following routines are available for the Axis Calibration method:

- Fine calibration
- Update revolution counters
- Reference calibration

The calibration equipment for Axis Calibration is delivered as a toolkit.

The actual instructions of how to perform the calibration procedure and what to do at each step is given on the FlexPendant. You will be guided through the calibration procedure, step by step.

#### Wrist Optimization method

Wrist Optimization is a method for improving reorientation accuracy for continuous processes like welding and gluing and is a complement to the standard calibration method.

The actual instructions of how to perform the wrist optimization procedure is given on the FlexPendant.

#### CalibWare - Absolute Accuracy calibration

The CalibWare tool guides through the calibration process and calculates new compensation parameters. This is further detailed in the *Application manual - CalibWare Field*.

If a service operation is done to a robot with the option Absolute Accuracy, a new absolute accuracy calibration is required in order to establish full performance. For most cases after replacements that do not include taking apart the robot structure, standard calibration is sufficient.

The Absolute Accuracy option varies according to the robot mounting position. This is printed on the robot name plate for each robot. The robot must be in the correct mounting position when it is recalibrated for absolute accuracy.

1.4.2 Fine calibration

General

Fine calibration is made using the Calibration Pendulum, see *Operating manual - Calibration Pendulum* or Axis calibration, see *Product manual - IRB 7600*.

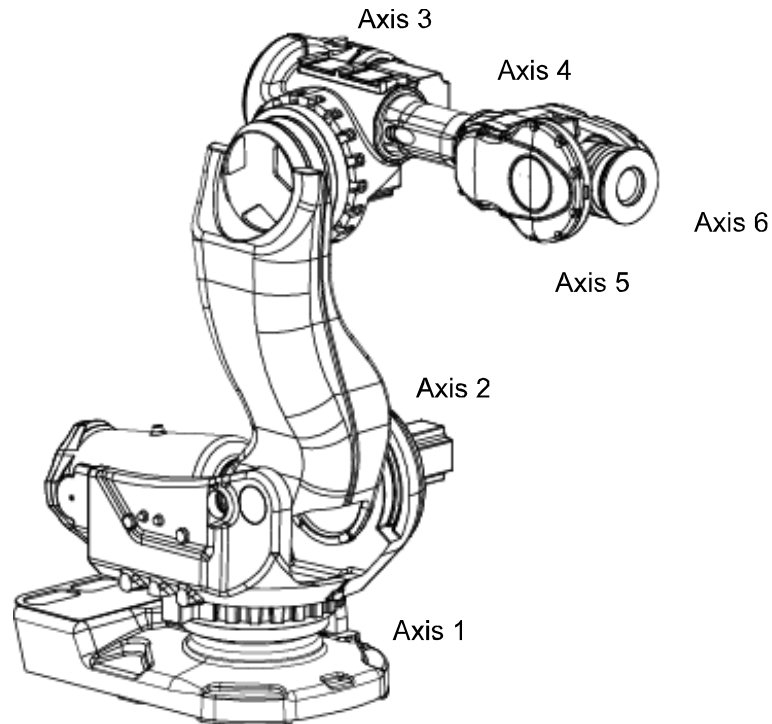

xx100000575

Calibration	Position
Calibration of all axes	All axes are in zero position
Calibration of axis 1 and 2	Axis 1 and 2 in zero position
	Axis 3 to 6 in any position
Calibration of axis 1	Axis 1 in zero position
	Axis 2 to 6 in any position

# 1 Description

---

## 1.4.3 Absolute Accuracy calibration

### 1.4.3 Absolute Accuracy calibration

---

#### Purpose

*Absolute Accuracy* is a calibration concept that improves TCP accuracy. The difference between an ideal robot and a real robot can be several millimeters, resulting from mechanical tolerances and deflection in the robot structure. *Absolute Accuracy* compensates for these differences.

Here are some examples of when this accuracy is important:

- Exchangeability of robots
- Offline programming with no or minimum touch-up
- Online programming with accurate movement and reorientation of tool
- Programming with accurate offset movement in relation to eg. vision system or offset programming
- Re-use of programs between applications

The option *Absolute Accuracy* is integrated in the controller algorithms and does not need external equipment or calculation.



#### Note

The performance data is applicable to the corresponding RobotWare version of the individual robot.



#### Note

Singularities might appear in slightly different positions on a real robot compared to RobotStudio, where *Absolute Accuracy* is off compared to the real controller.

---

#### What is included

Every *Absolute Accuracy* robot is delivered with:

- compensation parameters saved in the robot memory
- a birth certificate representing the *Absolute Accuracy* measurement protocol for the calibration and verification sequence.

A robot with *Absolute Accuracy* calibration has a label with this information on the manipulator.

*Absolute Accuracy* supports floor mounted, wall mounted, and ceiling mounted installations. The compensation parameters that are saved in the robot memory differ depending on which *Absolute Accuracy* option is selected.

---

#### When is *Absolute Accuracy* being used

*Absolute Accuracy* works on a robot target in Cartesian coordinates, not on the individual joints. Therefore, joint based movements (e.g. `MoveAbsJ`) will not be affected.

*Continues on next page*

If the robot is inverted, the Absolute Accuracy calibration must be performed when the robot is inverted.

### Absolute Accuracy active

Absolute Accuracy will be active in the following cases:

- Any motion function based on robtargets (e.g. `MoveL`) and `ModPos` on robtargets
- Reorientation jogging
- Linear jogging
- Tool definition (4, 5, 6 point tool definition, room fixed TCP, stationary tool)
- Work object definition

### Absolute Accuracy not active

The following are examples of when Absolute Accuracy is not active:

- Any motion function based on a jointtarget (`MoveAbsJ`)
- Independent joint
- Joint based jogging
- Additional axes
- Track motion



#### Note

In a robot system with, for example, an additional axis or track motion, the Absolute Accuracy is active for the manipulator but not for the additional axis or track motion.

### RAPID instructions

There are no RAPID instructions included in this option.

### Production data

Typical production data regarding calibration are:

Robot	Positioning accuracy (mm)		
	Average	Max	% Within 1 mm
IRB 7600-150/3.50	0.55	1.20	95
IRB 7600-340/2.80			
IRB 7600-325/3.1			
IRB 7600-400/2.55			
IRB 7600-500/2.55			

# 1 Description

## 1.4.4 Robot reference

### 1.4.4 Robot reference

#### Base

The holes shown in figure below are used for measuring the robot position when integrated in a production cell.

The holes are not available for option Foundry Plus.

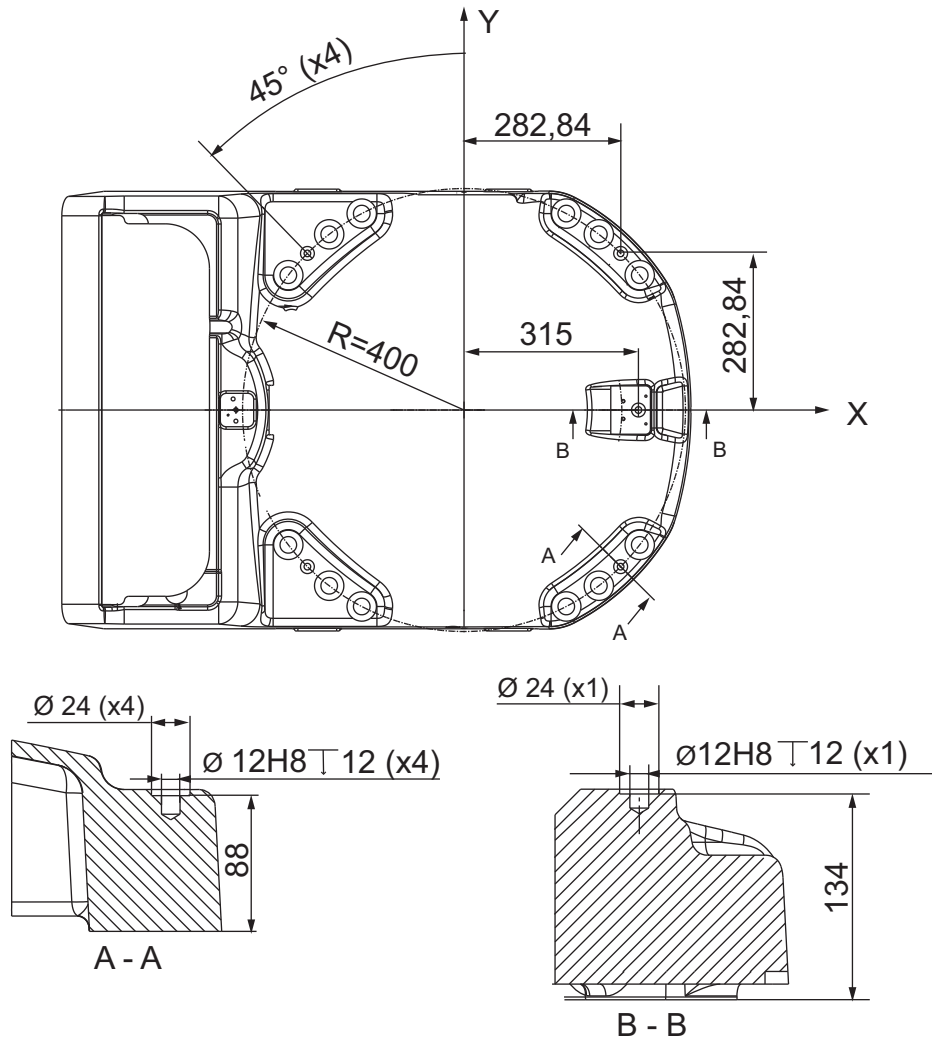

xx100000645

Continues on next page

Tool Flange

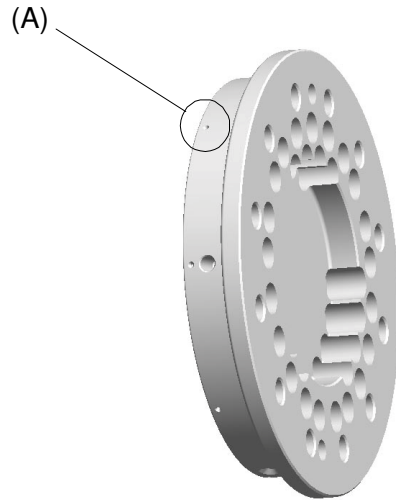

xx100000608

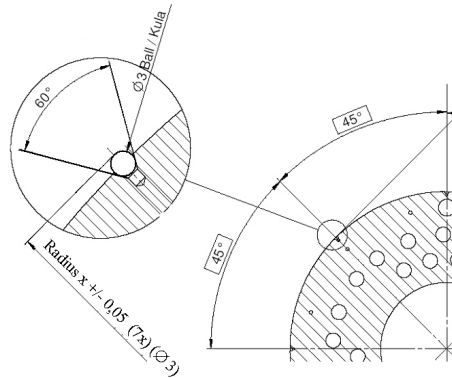

xx100000579

Robot	Radius X (mm) for references on tool flange
IRB 7600-150/3.50	R=113.5
IRB 7600-325/3.10	
IRB 7600-340/2.80	
IRB 7600-400/2.55	
IRB 7600-500/2.55	

# 1 Description

---

## 1.5.1 Introduction

## 1.5 Load diagrams

### 1.5.1 Introduction

---

#### Information



#### WARNING

It is very important to always define correct actual load data and correct payload of the robot. Incorrect definitions of load data can result in overloading of the robot.

If incorrect load data is used, and/or if loads outside the load diagram are used, the following parts can be damaged due to overload:

- motors
- gearboxes
- mechanical structure



#### WARNING

In RobotWare, the service routine LoadIdentify can be used to determine correct load parameters. The routine automatically defines the tool and the load.

See *Operating manual - OmniCore*, for detailed information.



#### WARNING

Robots running with incorrect load data and/or with loads outside the load diagram, will not be covered by robot warranty.

---

#### General

The load diagrams include a nominal payload inertia,  $J_0$  of  $15 \text{ kgm}^2$ , and an extra load of 50 kg at the upper arm housing.

At different moment of inertia the load diagram will be changed. For robots that are allowed tilted, wall or inverted mounted, the load diagrams as given are valid and thus it is also possible to use RobotLoad within those tilt and axis limits.

*Continues on next page*

### Control of load case with RobotLoad

To verify a specific load case, use the RobotStudio add-in RobotLoad.

The result from RobotLoad is only valid within the maximum loads and tilt angles. There is no warning if the maximum permitted arm load is exceeded. For over-load cases and special applications, contact ABB for further analysis.

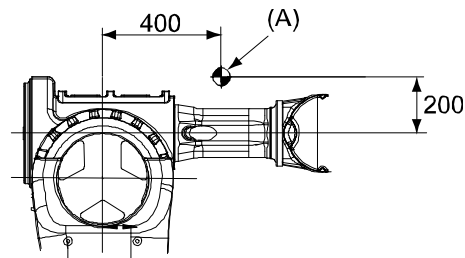

xx100000580

Pos	Description
A	Center of gravity 50 kg

# 1 Description

## 1.5.2 Load diagrams

### 1.5.2 Load diagrams

IRB 7600 - 500/2.55

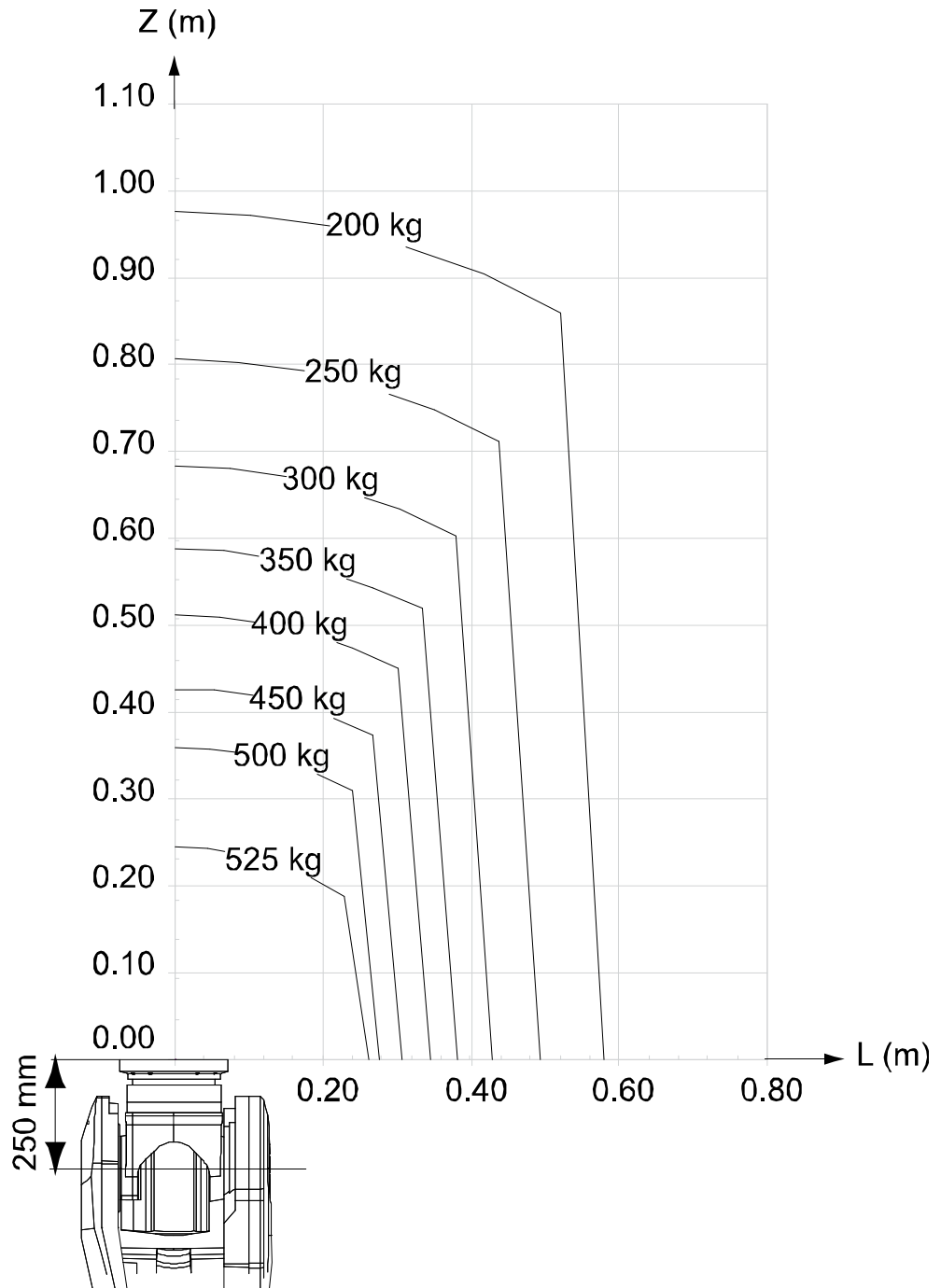

xx100000591

Continues on next page

# 1 Description

## 1.5.2 Load diagrams

Continued

### IRB 7600 - 500/2.55 "Vertical Wrist" ( $\pm 10^\circ$ )

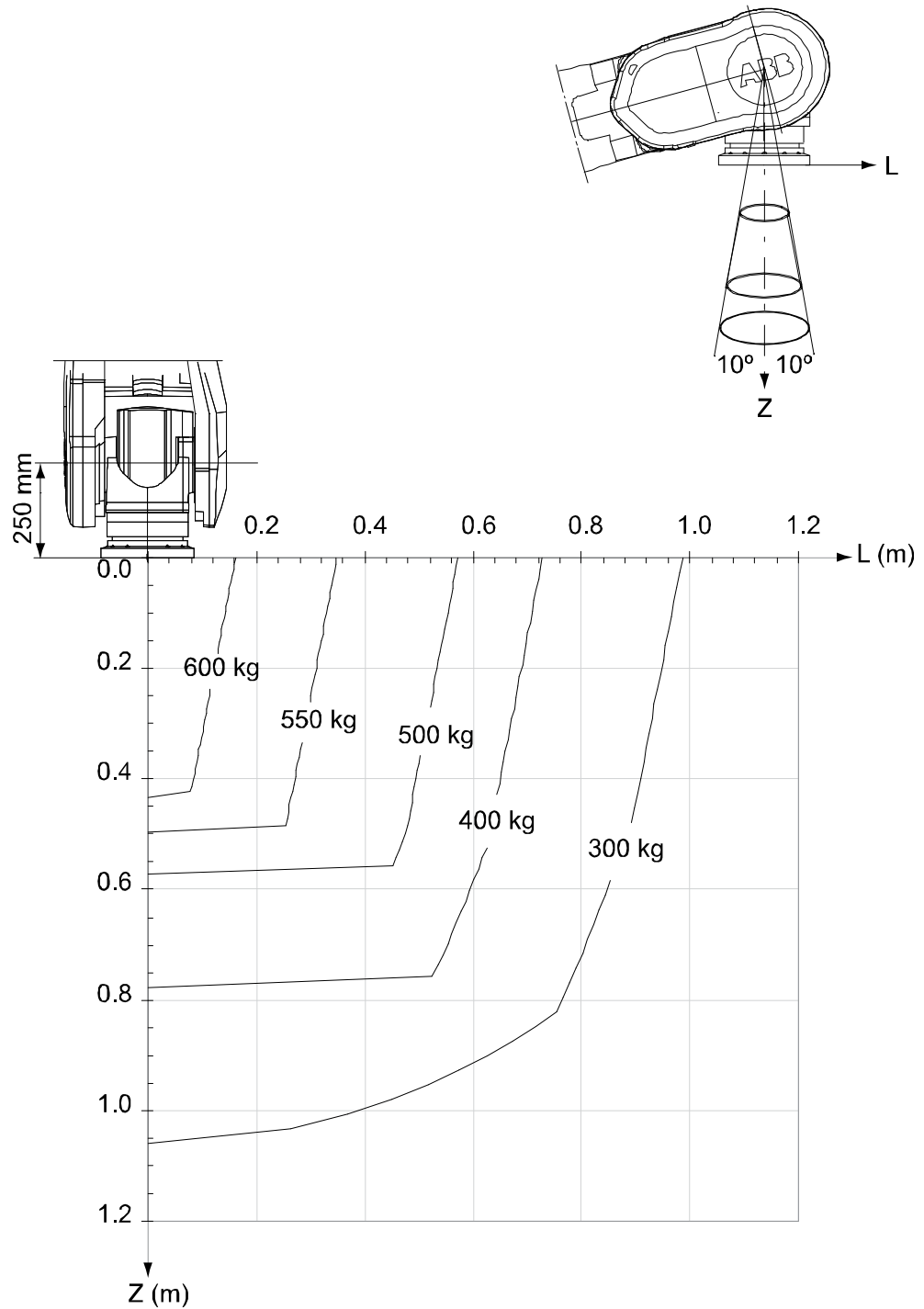

xx100000586

	Description
Max load	630 kg
Z <sub>max</sub>	0,392 m
L <sub>max</sub>	0,099 m

Continues on next page

# 1 Description

## 1.5.2 Load diagrams

Continued

IRB 7600 - 400/2.55

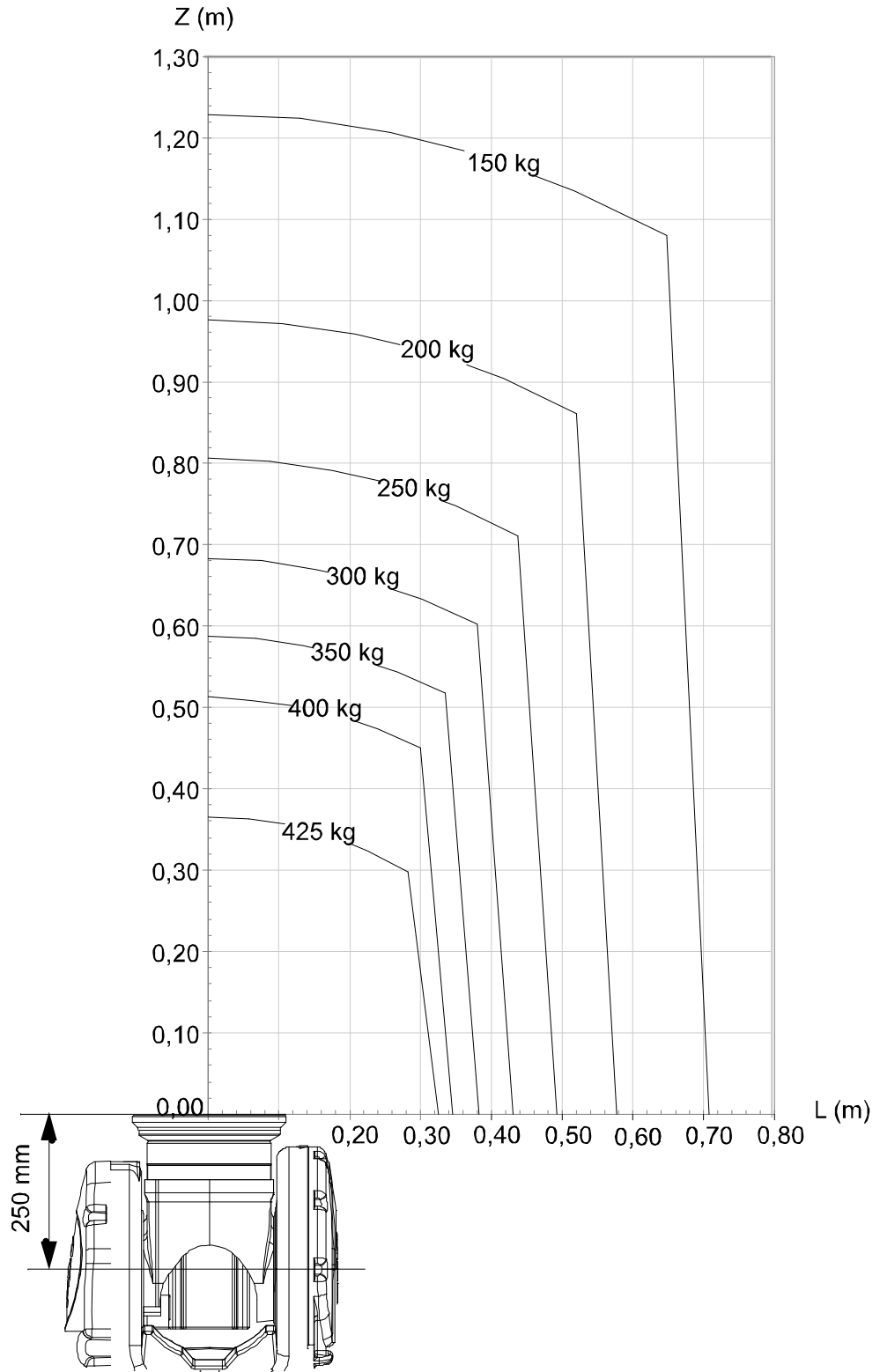

xx100000589

Continues on next page

# 1 Description

## 1.5.2 Load diagrams

Continued

### IRB 7600 - 400/2.55 "Vertical Wrist" ( $\pm 10^\circ$ )

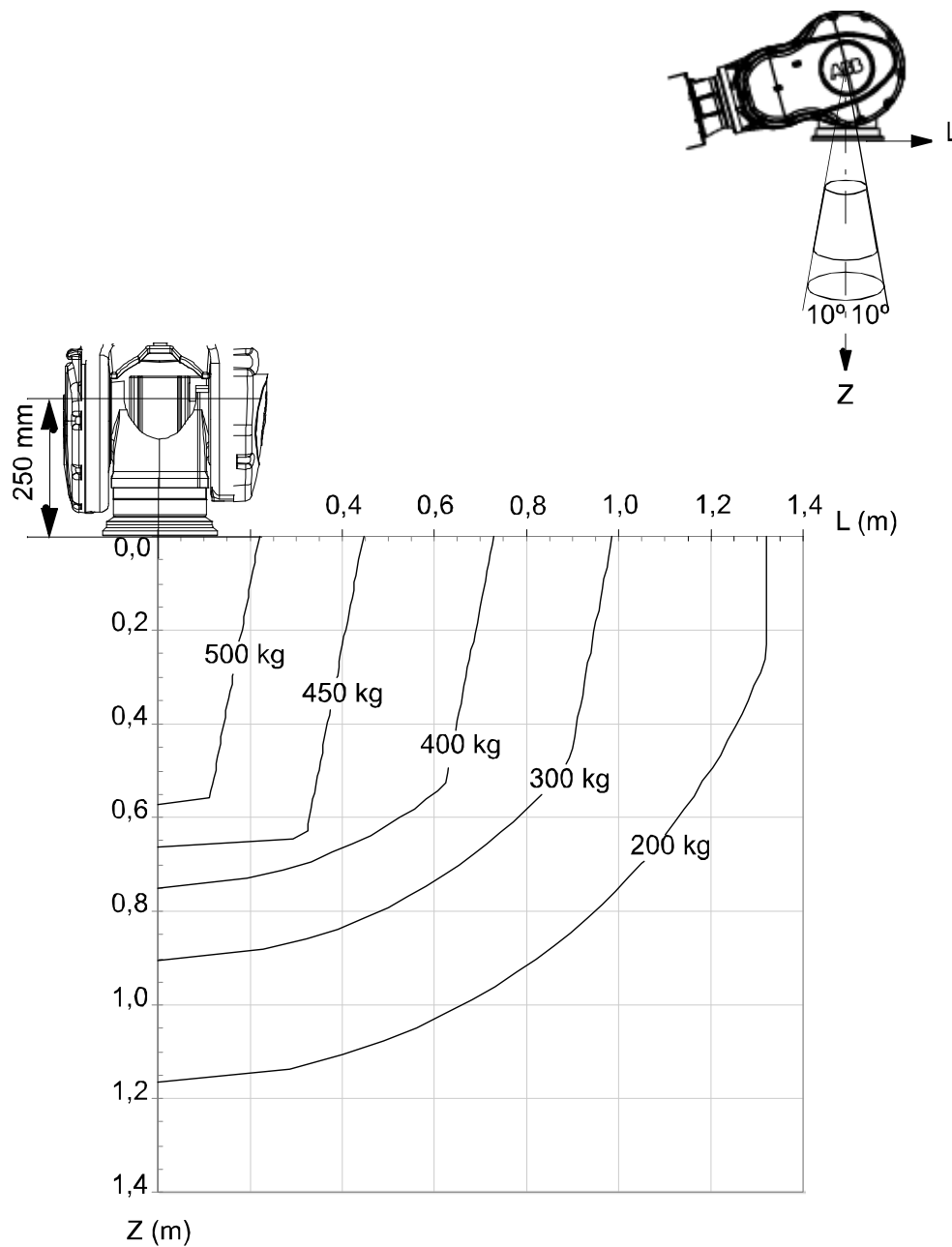

xx1000000584

	Description
Max load	540 kg
Z <sub>max</sub>	0,498 m
L <sub>max</sub>	0,103 m

Continues on next page

# 1 Description

## 1.5.2 Load diagrams

Continued

### IRB 7600 - 400/2.55 "LeanID", option 780-4

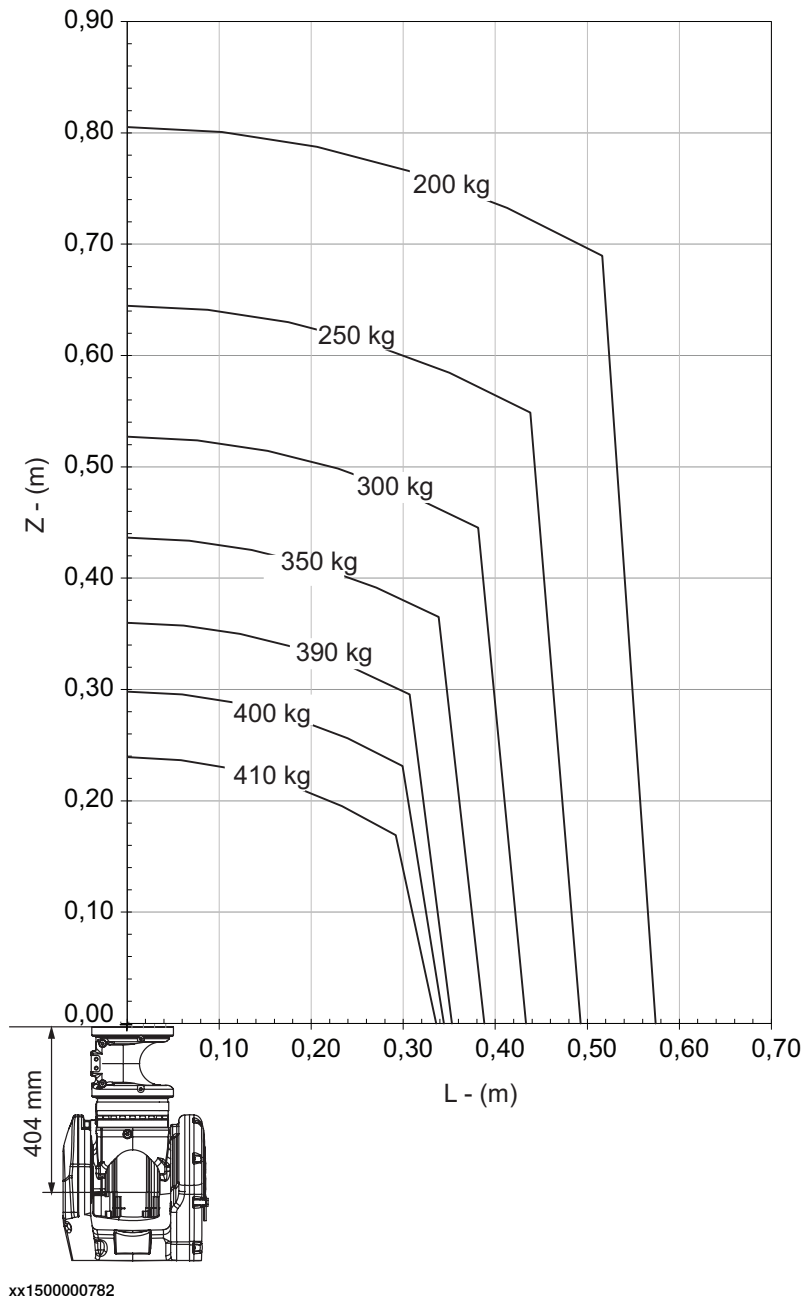

Continues on next page

IRB 7600 - 340/2.8

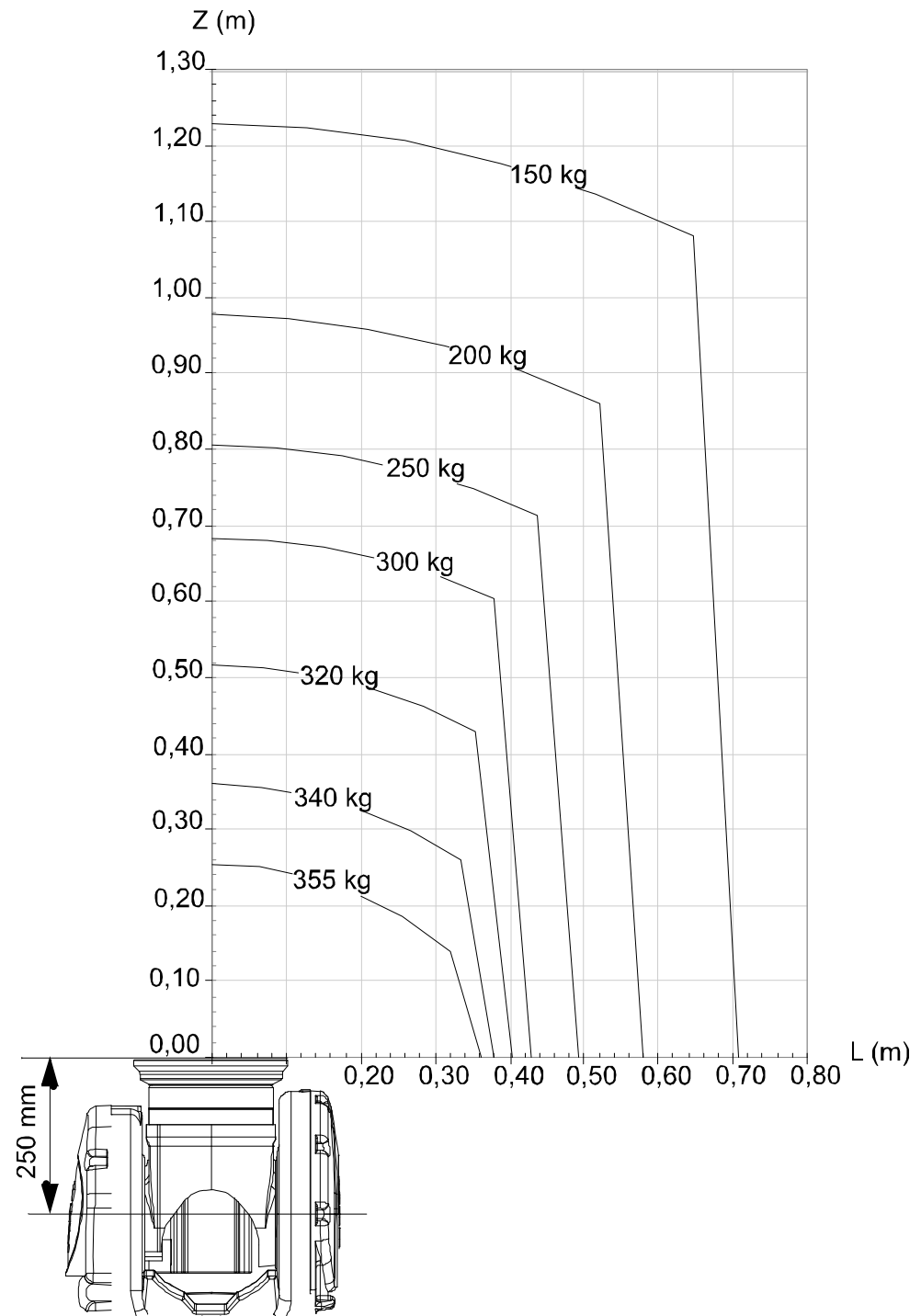

xx100000590

Continues on next page

# 1 Description

## 1.5.2 Load diagrams

Continued

### IRB 7600 - 340/2.8 "Vertical Wrist" ( $\pm 10^\circ$ )

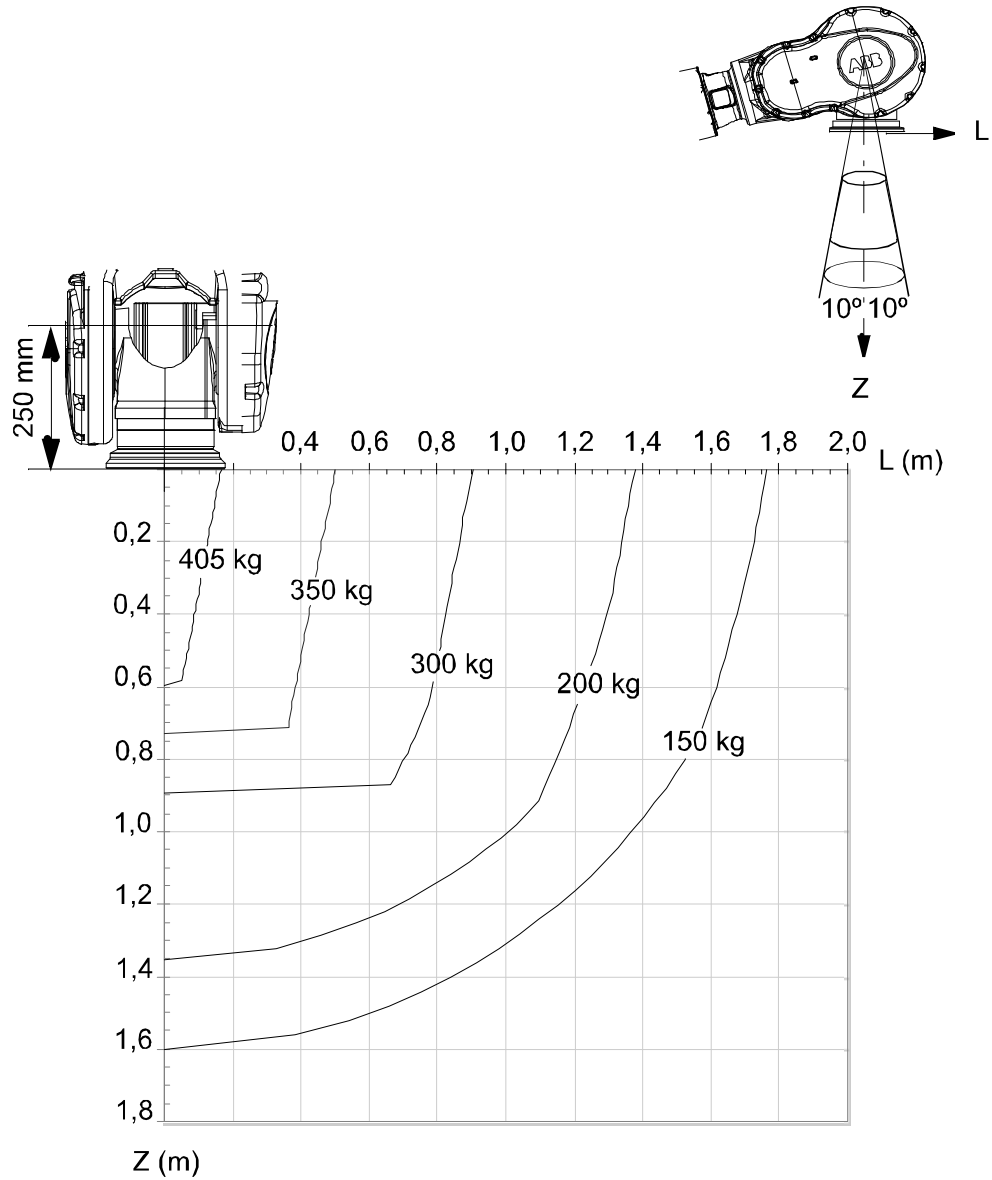

xx1000000583

For wrist down ( $0^\circ$  deviation from the vertical line).

	Description
Max load	420 kg
Z <sub>max</sub>	0,553 m
L <sub>max</sub>	0,121 m

Continues on next page

IRB 7600 - 340/2.8 "LeanID", option 780-4

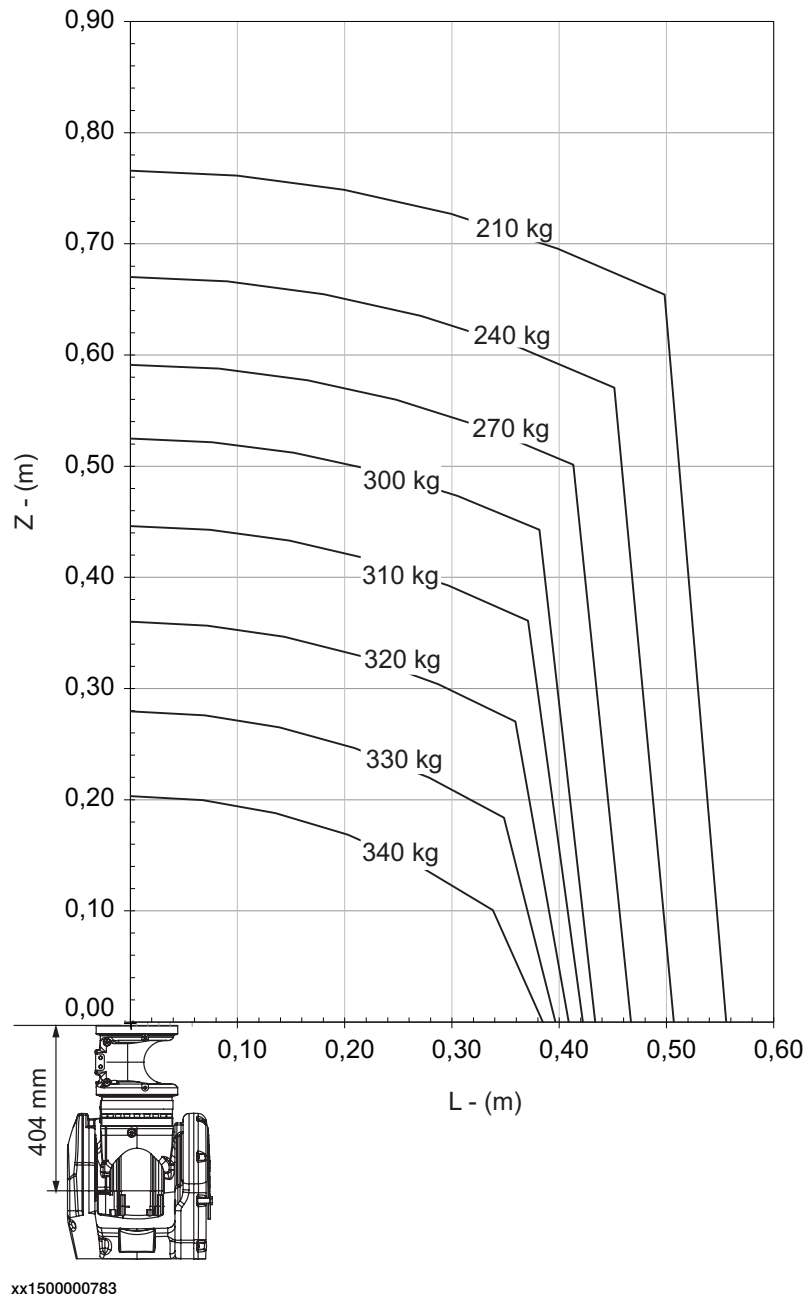

Continues on next page

# 1 Description

## 1.5.2 Load diagrams

Continued

IRB 7600 - 325/3.1

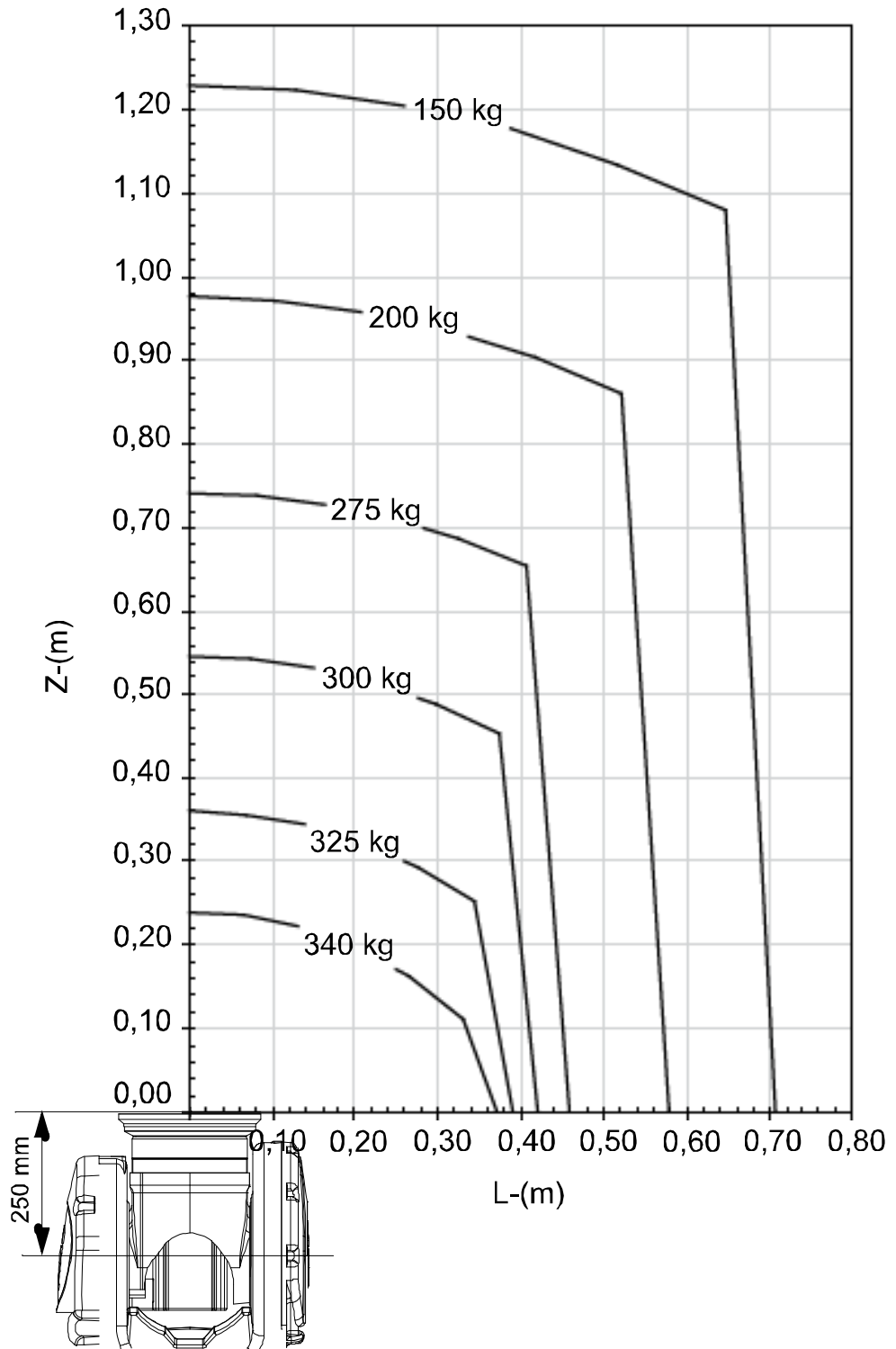

xx100000588

Continues on next page

# 1 Description

## 1.5.2 Load diagrams Continued

### IRB 7600 - 325/3.1 "Vertical Wrist" ( $\pm 10^\circ$ )

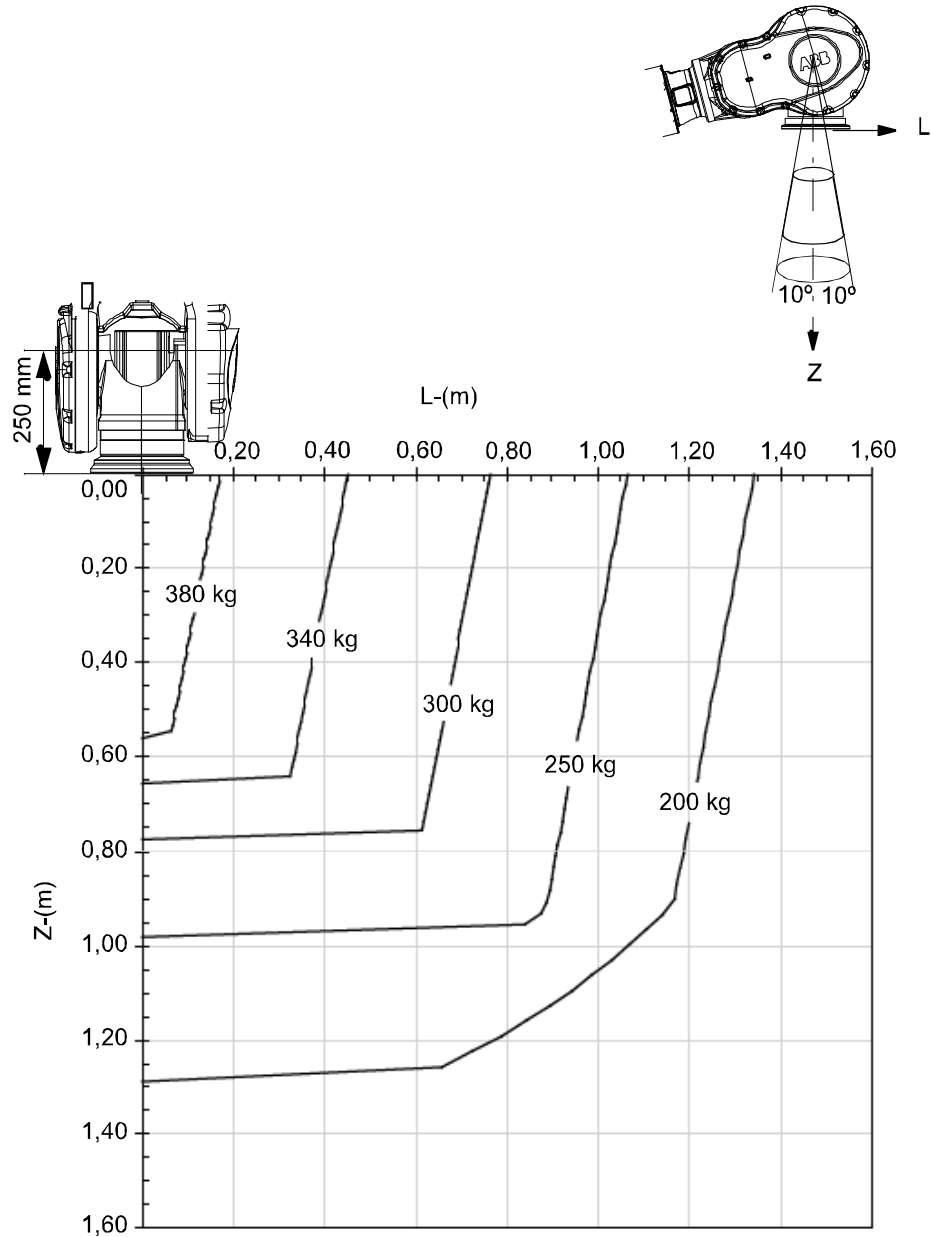

xx100000582

For wrist down ( $0^\circ$  deviation from the vertical line).

	Description
Max load	400 kg
Z <sub>max</sub>	0,519 m
L <sub>max</sub>	0,095 m

Continues on next page

# 1 Description

## 1.5.2 Load diagrams

Continued

### IRB 7600 - 325/3.1 "LeanID", option 780-4

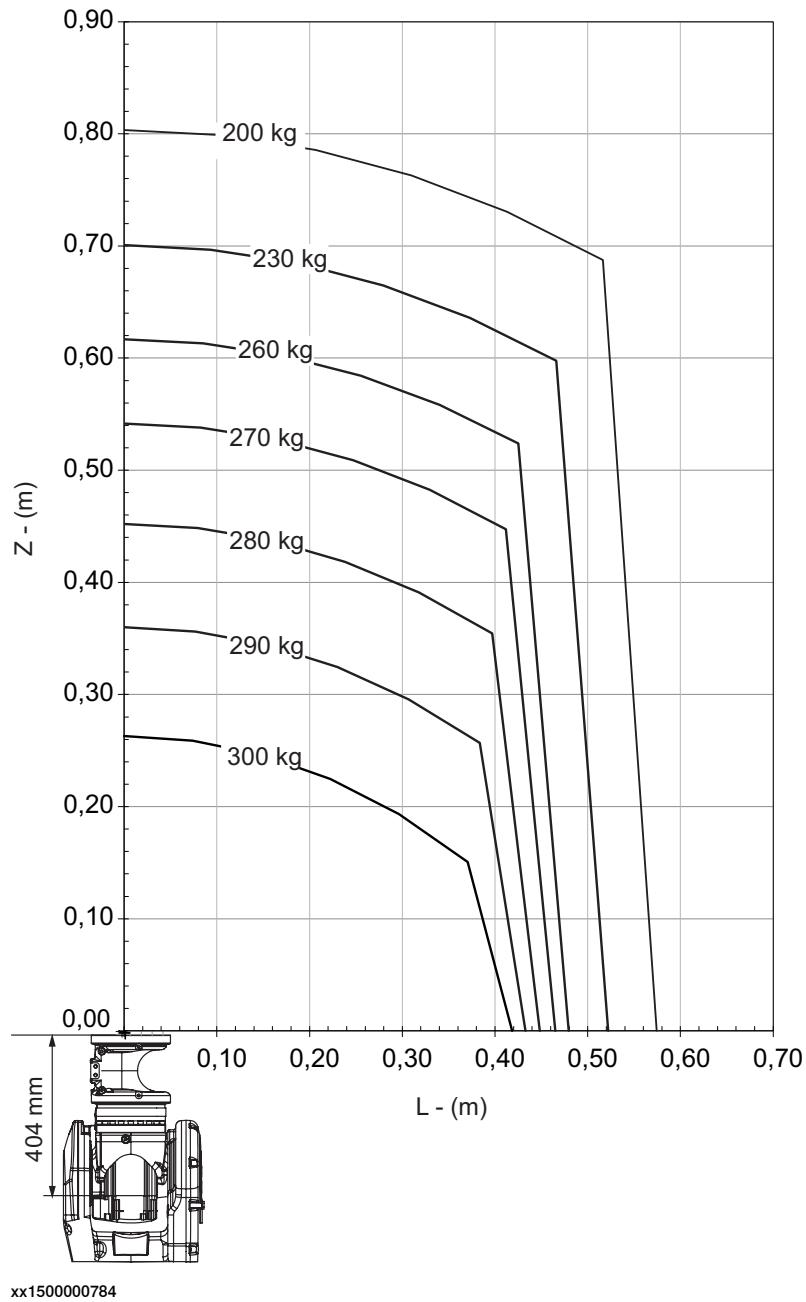

Continues on next page

IRB 7600 - 150/3.5

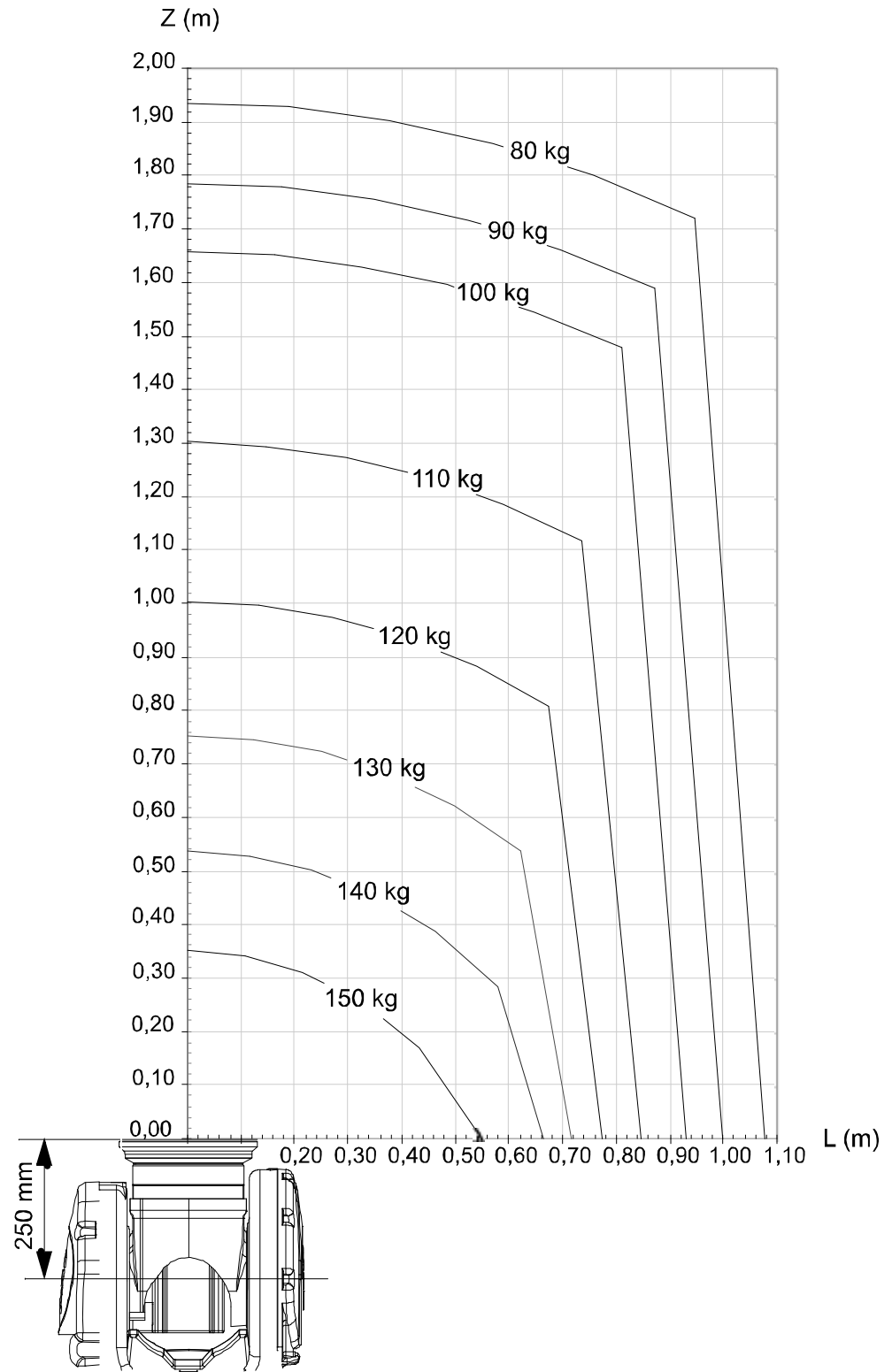

xx100000587

Continues on next page

# 1 Description

## 1.5.2 Load diagrams

Continued

### IRB 7600 - 150/3.5 "Vertical Wrist" ( $\pm 10^\circ$ )

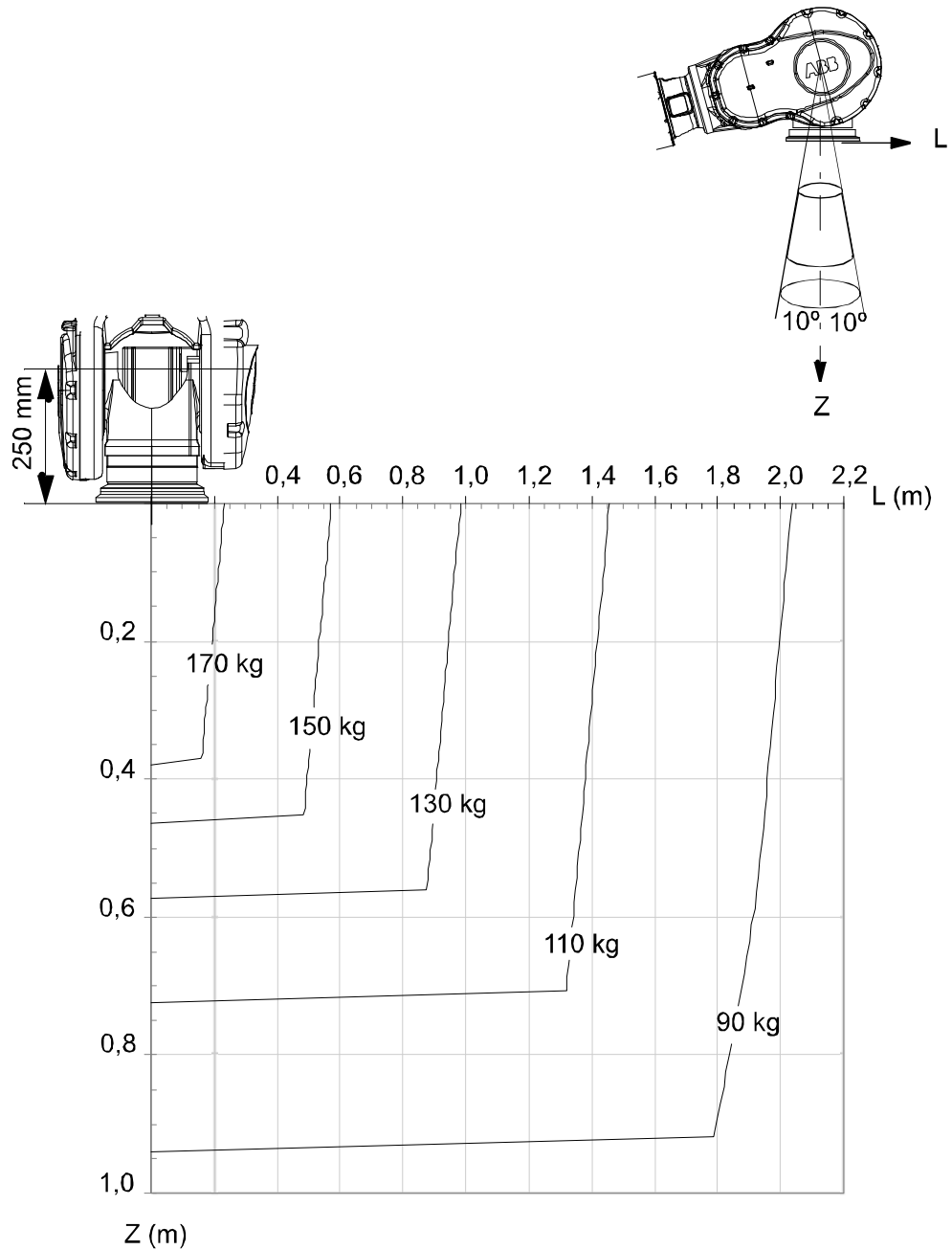

xx100000581

For wrist down ( $0^\circ$  deviation from the vertical line).

	Description
Max load	180 kg
Z <sub>max</sub>	0,337 m
L <sub>max</sub>	0,126 m

1.5.3 Max. load and moment of inertia for full and limited axis 5 (center down line) movement

1.5.3 Max. load and moment of inertia for full and limited axis 5 (center down line) movement



Note

Total load given as: Mass in kg, center of gravity (Z and L) in meter and moment of inertia ( $J_{0x}$ ,  $J_{0y}$ ,  $J_{0z}$ ) in  $\text{kgm}^2$ .  $L = \sqrt{X^2 + Y^2}$ , see Figure below

Full movement of axis 5 ( $\pm 100^\circ$ )

Axis	Maximum moment of inertia
5	$Ja_5 = \text{Mass} \times ((Z+0.250^i)^2 + L^2) + \max(J_{0x}, J_{0y}) \leq 500 \text{ kgm}^2$
6	$Ja_6 = \text{Mass} \times L^2 + J_{0z} \leq 315 \text{ kgm}^2$

<sup>i</sup> For option 780-4, LeanID=0,404 m

	Description
$J_{0x}$ , $J_{0y}$ , $J_{0z}$	Max. moment of inertia around the X, Y and Z axes at center of gravity.

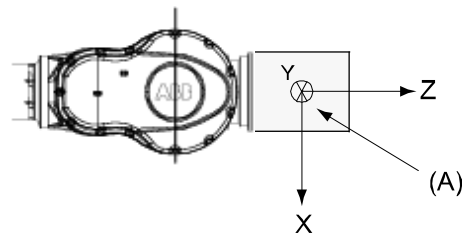

xx1000000593

Pos	Description
A	Center of gravity

Limited axis 5, center line down

Axis	Maximum moment of inertia
5	$Ja_5 = \text{Load} \times ((Z+0.250^i)^2 + L^2) + (J_{0x}, J_{0y}) \leq 550 \text{ kgm}^2$
6	$Ja_6 = \text{Load} \times L^2 + J_{0z} \leq 500 \text{ kgm}^2$

<sup>i</sup> For option 780-4, LeanID=0,404 m

	Description
$J_{0x}$ , $J_{0y}$ , $J_{0z}$	Max. moment of inertia around the X, Y and Z axes at center of gravity.

Continues on next page

# 1 Description

## 1.5.3 Max. load and moment of inertia for full and limited axis 5 (center down line) movement

Continued

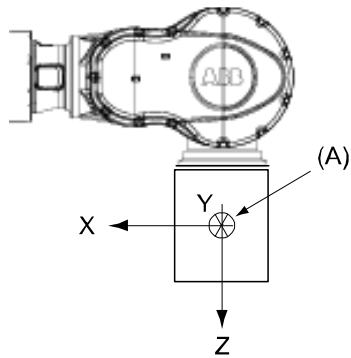

xx100000594

Pos	Description
A	Center of gravity

## 1.5.4 Wrist torque

### General

The table below shows the maximum permissible torque due to payload.



#### Note

The wrist torque values are for reference only, and should not be used for calculating permitted load offset (position of center of gravity) within the load diagram, since those also are limited by main axes torques as well as dynamic loads. Furthermore, arm loads will influence the permitted load diagram. To find the absolute limits of the load diagram, use the RobotStudio add-in RobotLoad.

Robot type	Max wrist torque axis 4 and 5	Max wrist torque axis 6	Max torque valid at load
IRB 7600 - 500/2.55	2990 Nm	1354 Nm	500 kg
IRB 7600 - 400/2.55	2990 Nm	1354 Nm	400 kg
IRB 7600 - 340/2.8	2746 Nm	1265 Nm	300 kg
IRB 7600 - 325/3.1	2681 Nm	1241 Nm	278 kg
IRB 7600 - 150/3.5	1700 Nm	800 Nm	100 kg

# 1 Description

## 1.5.5 Mounting equipment

### 1.5.5 Mounting equipment

#### General

Extra loads can be mounted on the upper arm housing, the lower arm, and on the frame. Definitions of distances and masses are shown in Figure below and Figure on next page. The robot is supplied with holes for mounting extra equipment (see Figure in next chapter). Maximum permitted arm load depends on center of gravity of arm load and robot payload.

#### Upper arm

Permitted extra load on upper arm housing plus the maximum handling weight (see Figure below):

$M1 \leq 50 \text{ kg}$  with distance  $a \leq 500 \text{ mm}$ , center of gravity in axis 3 extension.

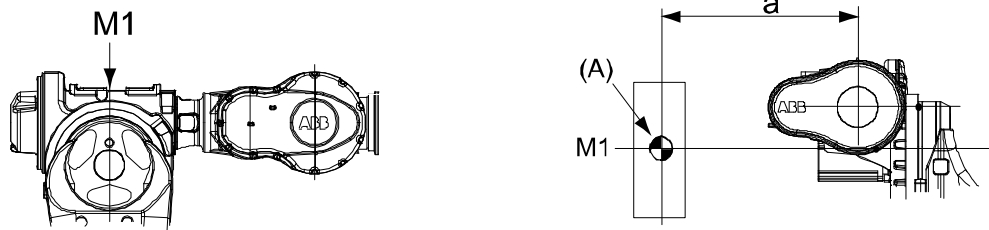

xx1000000595

Pos	Description
A	Mass center

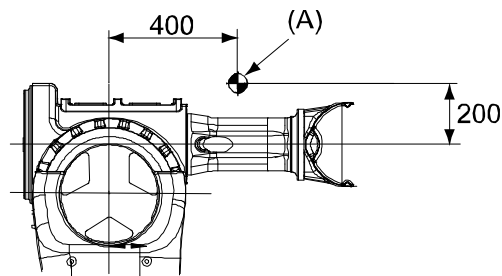

xx1000000580

Pos	Description
A	Center of gravity 50 kg

Continues on next page

# 1 Description

## 1.5.5 Mounting equipment

*Continued*

### Frame (Hip Load)

Permitted extra load on frame	$J_H = 200 \text{ kgm}^2$
Recommended position (see Figure below)	$J_{H0} + M4 \times R^2$ where $J_H$ is the moment of inertia of the equipment $R$ is the radius (m) from the center of axis $M4$ is the total mass (kg) of the equipment including bracket and harness ( $\leq 500 \text{ kg}$ ).

### View from above

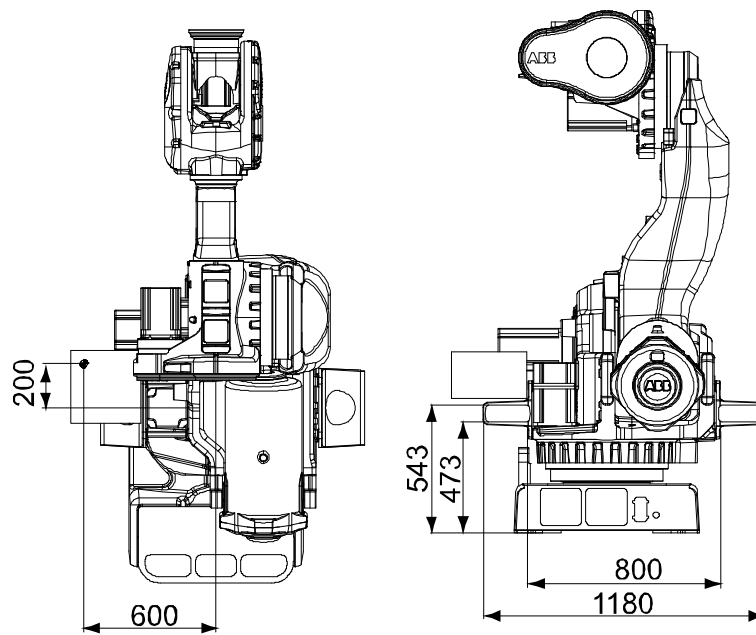

xx100000596

# 1 Description

## 1.5.6 Mounting of hip load

### 1.5.6 Mounting of hip load

#### General

The extra load can be mounted on the frame. Holes for mounting see Figure below. When mounting on the frame all the four holes (2x2, Ø16) on one side must be used.

#### Holes for mounting extra equipment

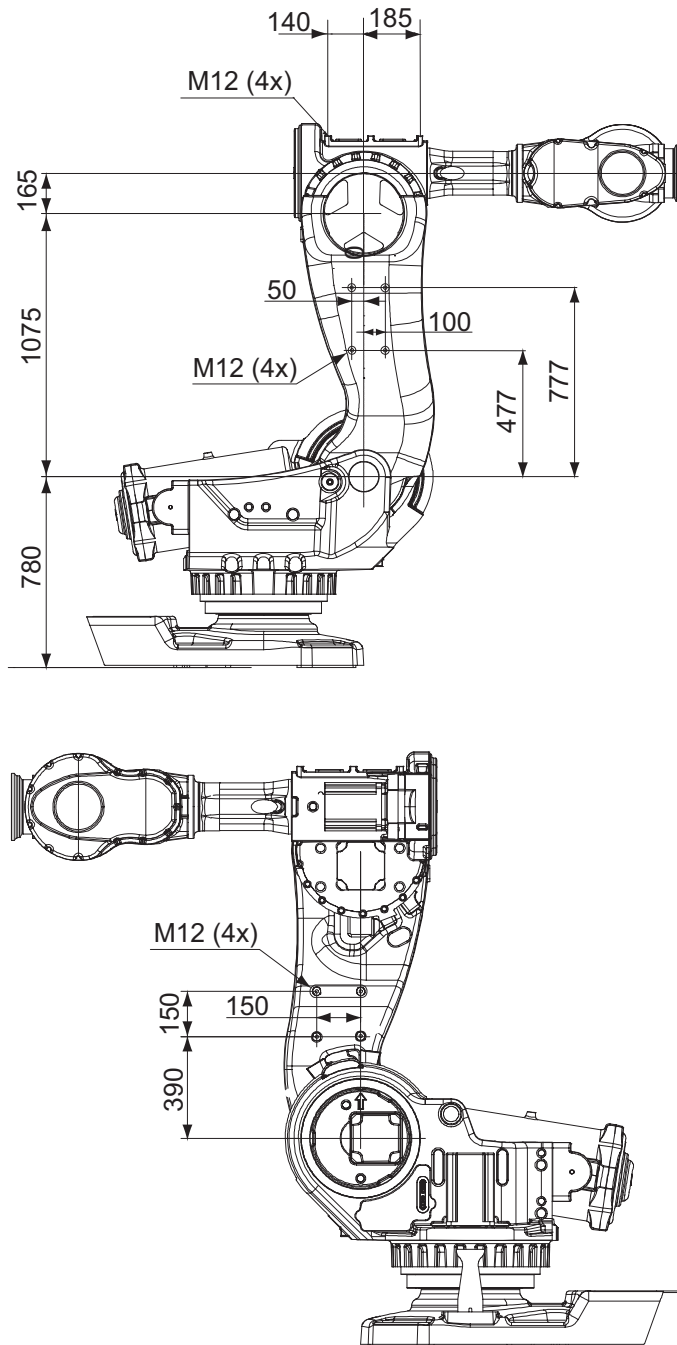

xx100000597

Continues on next page

# 1 Description

## 1.5.6 Mounting of hip load

*Continued*

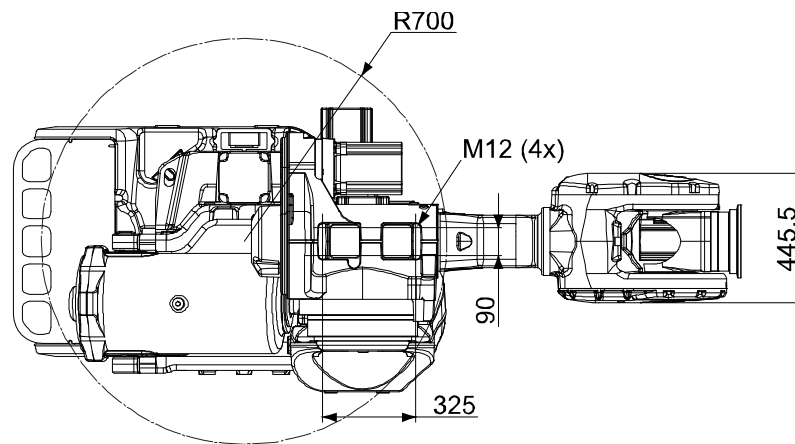

xx100000599

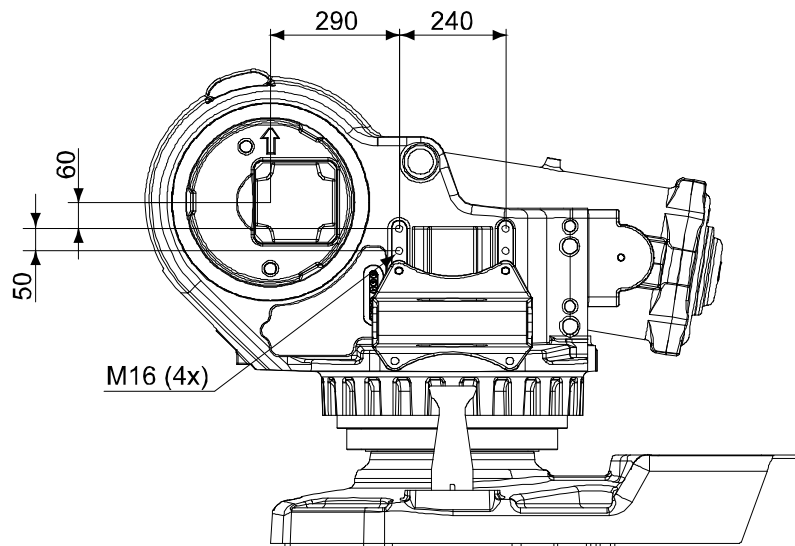

xx100000598

*Continues on next page*



## 1.5.7 Maximum TCP acceleration

### General

Higher values can be reached with lower loads than the nominal because of our dynamical motion control QuickMove2. For specific values in the unique customer cycle, or for robots not listed in the table below, we recommend to use RobotStudio.

### Maximum Cartesian design acceleration for nominal loads

Robot type	E-stop Max acceleration at nominal load COG [m/s <sup>2</sup> ]	Controlled Motion Max acceleration at nominal load COG [m/s <sup>2</sup> ]
IRB 7600 - 500/2.55	34	15
IRB 7600 - 400/2.55	38	18
IRB 7600 - 340/2.8	41	18
IRB 7600 - 325/3.10	45	18
IRB 7600 - 150/3.50	55	24



#### Note

Acceleration levels for emergency stop and controlled motion includes acceleration due to gravitational forces. Nominal load is defined with nominal mass and cog with max offset in Z and L (see the load diagram).

# 1 Description

---

## 1.6.1 Introduction

## 1.6 Maintenance and troubleshooting

### 1.6.1 Introduction

---

#### General

The robot requires only a minimum of maintenance during operation. It is designed to make it as easy to service as possible:

- Maintenance-free AC motors are used
- Liquid grease or oil is used for the gear boxes
- The cabling is routed for longevity, and in the unlikely event of a failure, its modular design makes it easy to change

---

#### Maintenance

The maintenance intervals depend on the use of the robot, the required maintenance activities also depends on selected options. For detailed information on maintenance procedures, see Maintenance section in the Product Manual.

1.7 Robot motion

1.7.1 Introduction

Type of motion

Axis	Type of motion	Range of movement	
		from	to
1	Rotation motion	+180°	-180°
2	Arm motion	+85°	-60°
3	Arm motion	+60°	-180°
4	Wrist motion	+300°	-300°
5	Bend motion	+100°	-100°
6	Turn motion	+360° Default <sup>i</sup> +67 Rev. max.	-360° Default -67 Rev. <sup>ii</sup> max. <sup>iii</sup>

<sup>i</sup> Working range +220° to -220° for robots with LeanID, option 780-4.

<sup>ii</sup> Rev. = Revolutions

<sup>iii</sup> The default working range for axis 6 can be extended by changing parameter values in the software. Option 610-1 "Independent axis" can be used for resetting the revolution counter after the axis has been rotated (no need for "rewinding" the axis).

Working range axis 5 and axis 6 for LeanID, option 780-4

Allowed working area for axis 6 related to axis 5 position is shown in the figure below.

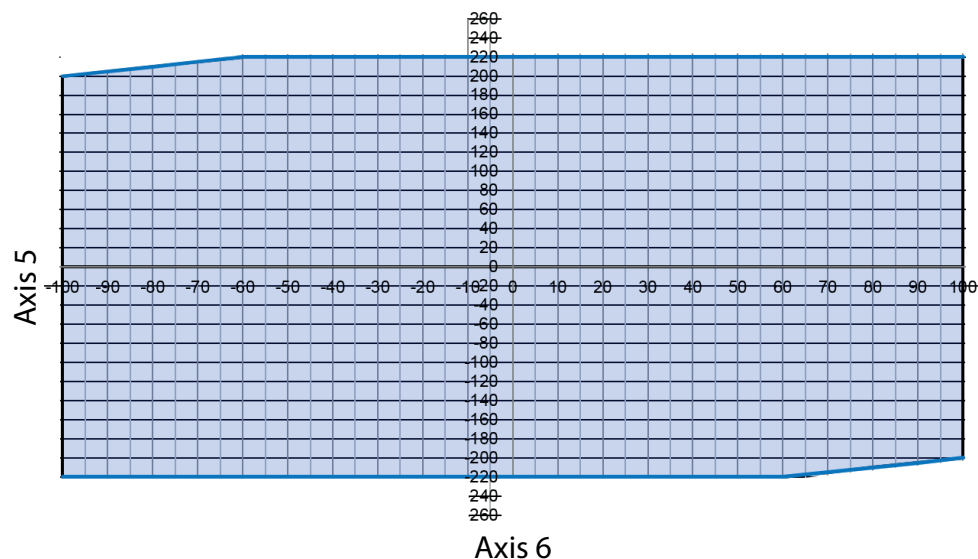

xx150000889

Continues on next page

# 1 Description

## 1.7.1 Introduction

*Continued*

### IRB 7600 - 400/2.55 and IRB 7600 - 500/2.55

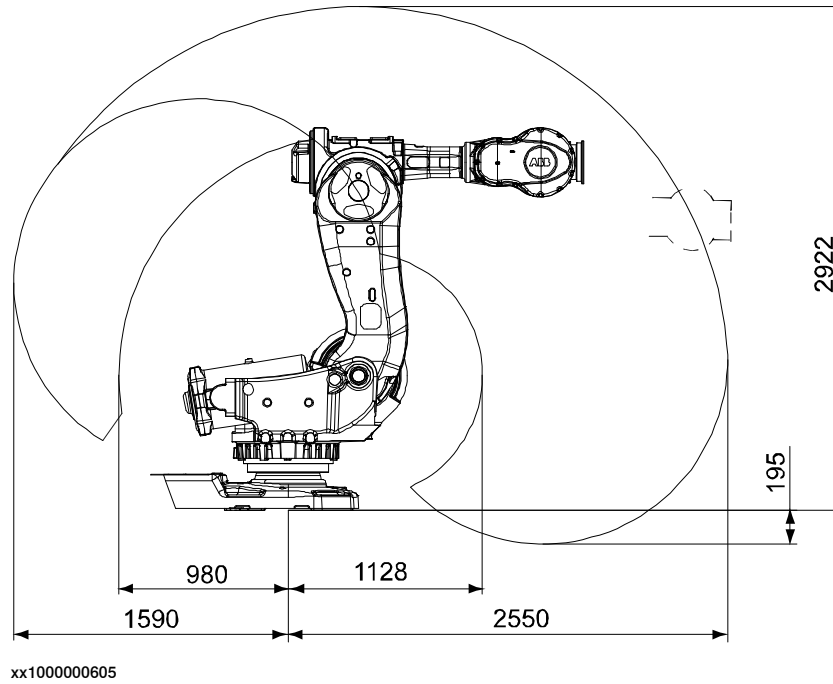

### IRB 7600 - 340/2.8

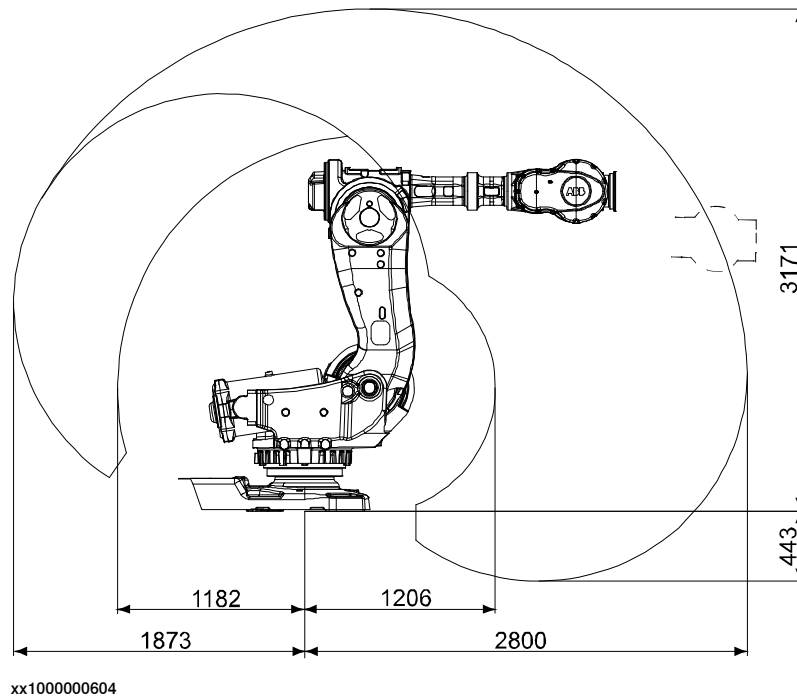

*Continues on next page*

# 1 Description

## 1.7.1 Introduction

*Continued*

### IRB 7600 - 325/3.1

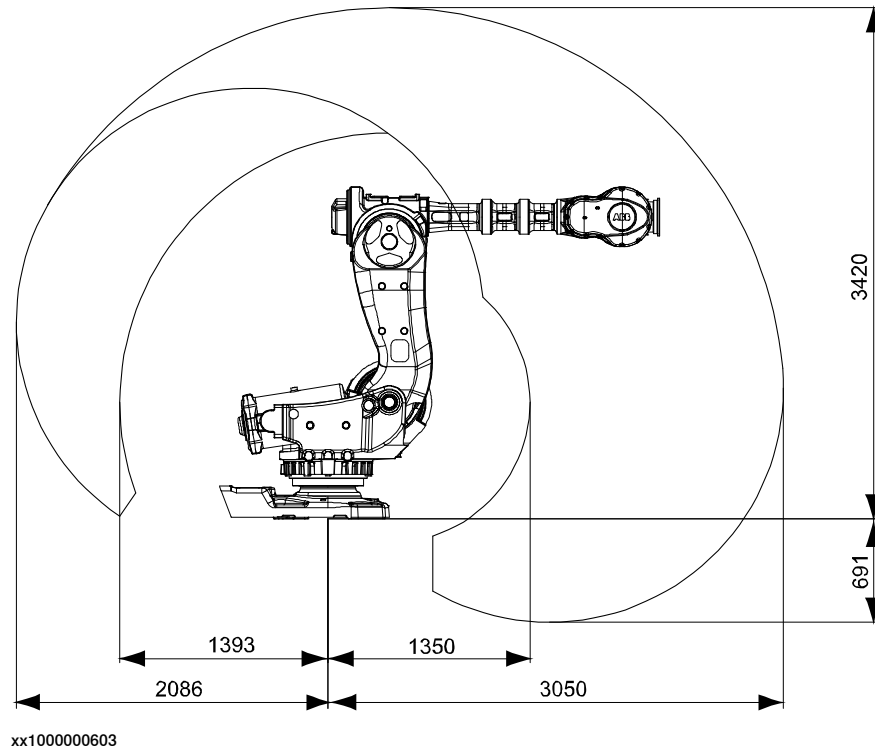

### IRB 7600 - 150/3.5

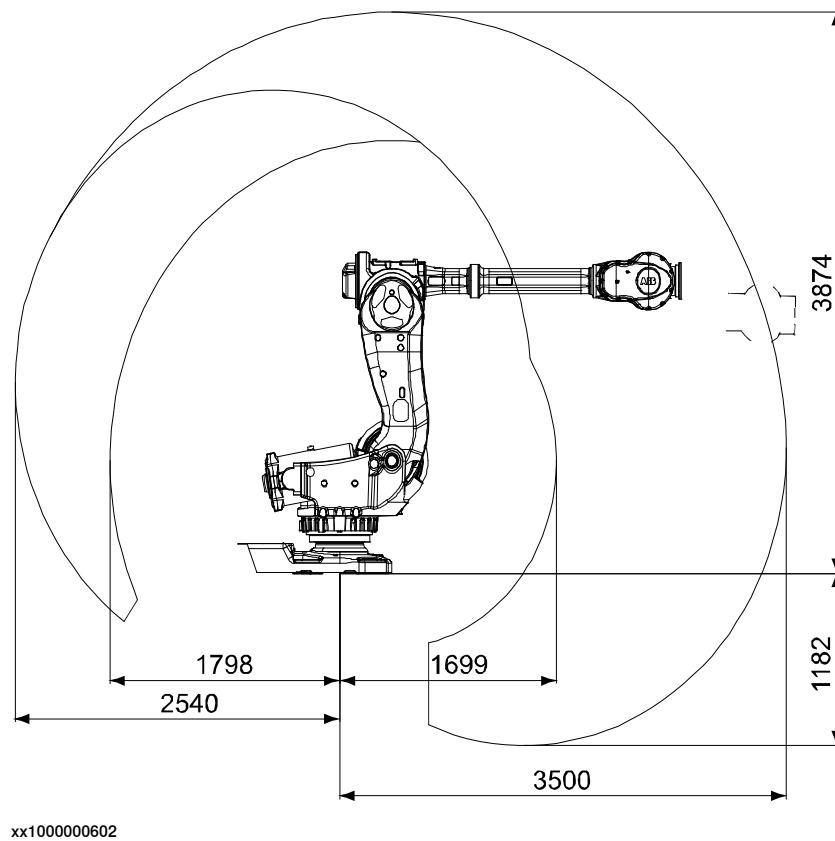

# 1 Description

## 1.7.2 Performance according to ISO 9283

### 1.7.2 Performance according to ISO 9283

#### General

At rated maximum load, maximum offset and 1.6 m/s velocity on the inclined ISO test plane, with all six axes in motion. Values in the table below are the average result of measurements on a small number of robots. The result may differ depending on where in the working range the robot is positioning, velocity, arm configuration, from which direction the position is approached, the load direction of the arm system. Backlashes in gearboxes also affect the result.

The figures for AP, RP, AT and RT are measured according to figure below.

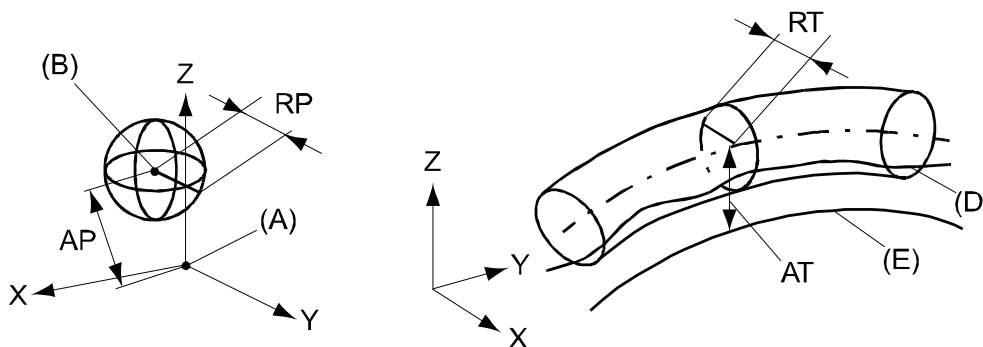

xx0800000424

Pos	Description	Pos	Description
A	Programmed position	E	Programmed path
B	Mean position at program execution	D	Actual path at program execution
AP	Mean distance from programmed position	AT	Max deviation from E to average path
RP	Tolerance of position B at repeated positioning	RT	Tolerance of the path at repeated program execution

IRB 7600	-500/2.55	-400/2.55	-340/2.8	-150/3.5	-325/3.1
Pose accuracy, AP (mm)	0.09	0.10	0.18	0.10	0.11
Pose repeatability, RP (mm)	0.08	0.19	0.27	0.19	0.10
Pose stabilization time, Pst (s) within 0.4 <sup>i</sup> (0.6 <sup>ii</sup> ) mm of the position	0.30	0.38	0.18	0.55	0.24
Path accuracy, AT (mm)	3.43	2.95	2.05	1.21	1.36
Path repeatability, RT (mm)	0.30	1.27	0.23	0.40	0.59

<sup>i</sup> Valid for variant 400/2.55 and 500/2.55

<sup>ii</sup> Valid for variant 340/2.8, 150/3.5 and 325/3.1

The above values are the range of average test results from a number of robots.

## 1.7.3 Velocity

### General

Maximum axis speeds.

IRB 7600 Axis No.	- 500/2.55	- 400/2.55	- 340/2.8	- 150/3.5	- 325/3.1
	(°/s)	(°/s)	(°/s)	(°/s)	(°/s)
1	75	75	75	100	75
2	50	60	60	60	50
3	55	60	60	60	55
4	100	100	100	100	100
5	100	100	100	100	100
6	160	160	160	190	160

There is a supervision function to prevent overheating in applications with intensive and frequent movements.

# 1 Description

---

## 1.7.4 Robot stopping distances and times

### 1.7.4 Robot stopping distances and times

---

#### Introduction

The stopping distances and times for category 0 and category 1 stops, as required by EN ISO 10218-1 Annex B, are listed in *Product specification - Robot stopping distances according to ISO 10218-1 (3HAC048645-001)*.

---

## 2 DressPack

### 2.1 General

#### 2.1.1 Introduction

---

##### DressPack

Includes options for Upper arm, Lower arm and Floor pos C, D and E, see Figure below. These are described separately below but are designed as a complete package for various applications.

The DressPack for the floor contains customer signals.

The DressPack for upper and lower arm contains process cable packages including signals, process media (water and/or air) and power feeding (for Spot Welding power) for customer use.

Necessary supports and brackets are also included.

The routing of the process cable package on the robot is available in different configurations.

For the upper arm there are also internal routing alternative for some of the manipulator variants and Material Handling option.

---

##### Spot welding

The package supplies the transformer gun/gripper with necessary media, such as compressed air, electrical power and software.

**Note**

Note that some figures within Chapter 2 show the IRB 6600 instead of the IRB 7600. This is valid where principles and dimensions are equal between IRB 6600 and IRB 7600.

*Continues on next page*

## 2 DressPack

### 2.1.1 Introduction

*Continued*

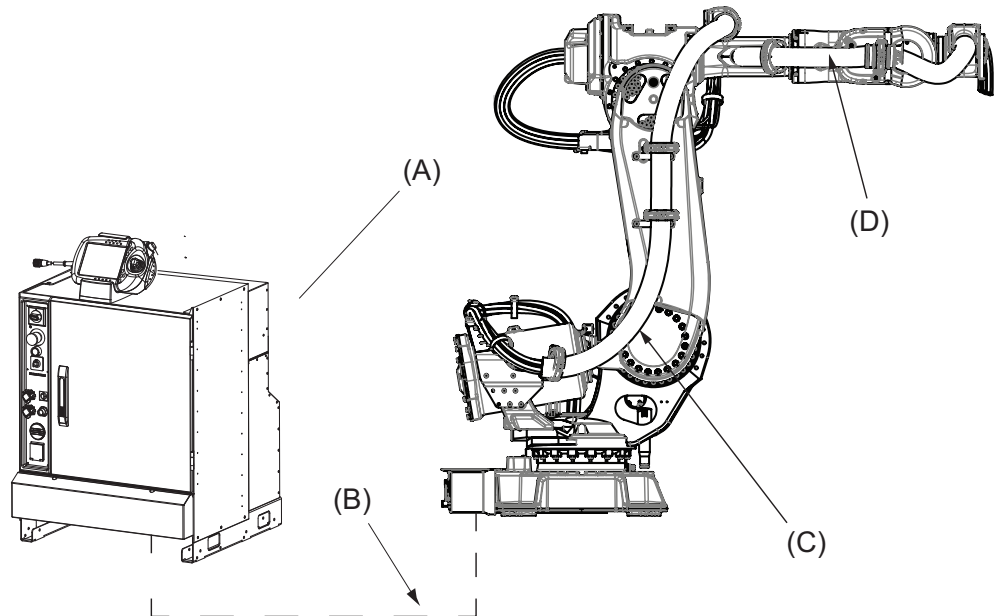

xx100000424

Pos	Description
A	Robot controller, (including 7th axis drive for servo gun)
B	DressPack, Floor
C	DressPack, Lower arm
D	DressPack, Upper arm

## 2.1.2 Product range

### DressPack solutions for different user's needs

The robot can be equipped with the well integrated cable and hose packages in the DressPack option. The DressPack is designed in close conjunction with the development of the manipulator and is therefore well synchronized with the robot. As there is a big span between different user's need of flexibility, depending of the complexity of the operation/wrist movements, there are three major levels of dress pack solutions available, see Figure below.

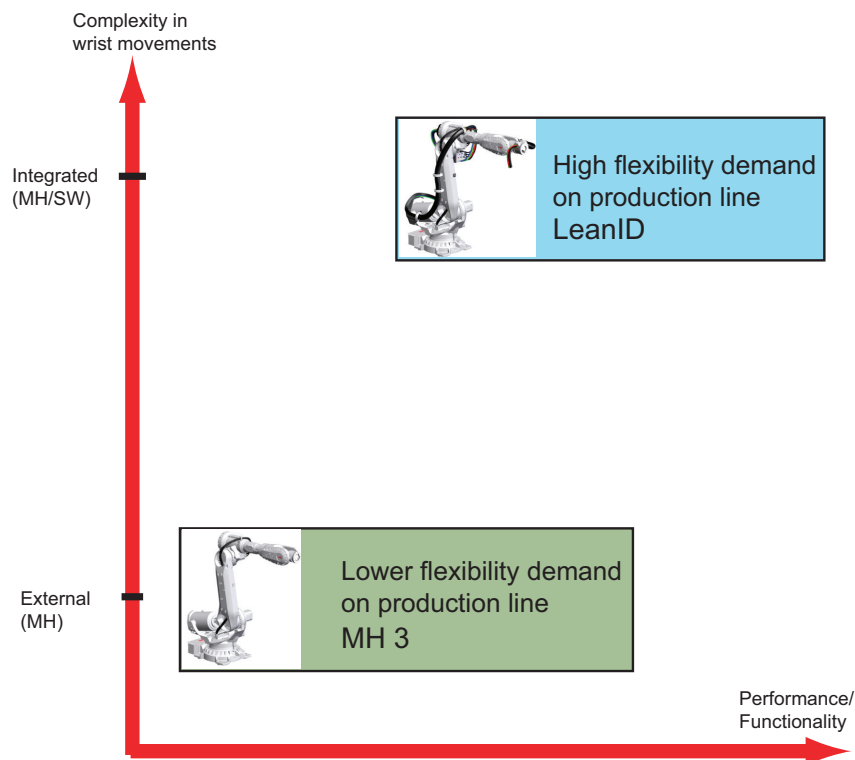

### Integrated

This type of dress pack is intended for a production where there are many complex wrist movements and the need for flexibility in changing products is high.

Available options are 3325-x and 3326-x for material handling/spot welding, the LeanID concept.

### External

This type of dress pack is recommended where there are less complexity in wrist movements. This normally occurs when there are not many different products running in the production cell. This package requires more individual adjustment to optimize towards robot program at set up.

Available options are 3325-11/12/13/14 and 3326-11/12/13/14 for material handling.

## 2 DressPack

---

### 2.1.3 Limitations of robot movements

### 2.1.3 Limitations of robot movements

---

#### General

When using DressPack options on the upper arm the robot movements will be limited. The position of bracket installed on axis 6 must be taken in consideration when optimizing the possible robot movements.

- The axis 5 working range is limited to +/- 110 degrees due to the axis 6 bracket attachment (when applicable).
- In bending backwards positions there are limitations due to interference with manipulator or Water and Air unit (if such is mounted).

---

#### Restrictions for LeanID

Limitation for axis 6 depends on how the dress pack is assembled at the tool and how adjustment has been done.

Axis	Working range
Axis 6	220° to -220°

#### 2.1.4 Impact on DressPack lifetime

---

##### General

There are some robot movements/positions that shall be avoided in the robot production program. This to improve the lifetime significantly of external upper arm DressPack and wear parts, for example, protection hose, hose reinforcement, and protective sleeves.

- The axis 5 movement is not allowed to press the DressPack against the robot upper arm.
- Combined rotation of the wrist axes must be limited so that the DressPack is not wrapped hard against the upper arm.

See the product manual for more detailed information and recommended adjustments.

## 2 DressPack

### 2.2.1 Introduction

## 2.2 DressPack

### 2.2.1 Introduction

#### Available DressPack configurations for Material Handling

The table below shows the different DressPack configurations available for Material Handling.

	Lower arm	Upper arm
Material Handling	Option 3325-5x, Base to axis 3 Internal routing in lower arm	Option 3326-1x, Axis 3 to axis 6 External routing
		Option 3326-3x, Axis 3 to axis 6 (LID) Internal routing

#### Available DressPack configurations for Spot Welding

The table below shows the different DressPack configurations available for Spot Welding.

	Lower arm	Upper arm
Spot Welding	Option 3325-5x/6x Base to axis 3	Option 3326-5x/6x Int. Axis 3 to 6 (LeanID) Internal routing

#### Lower arm

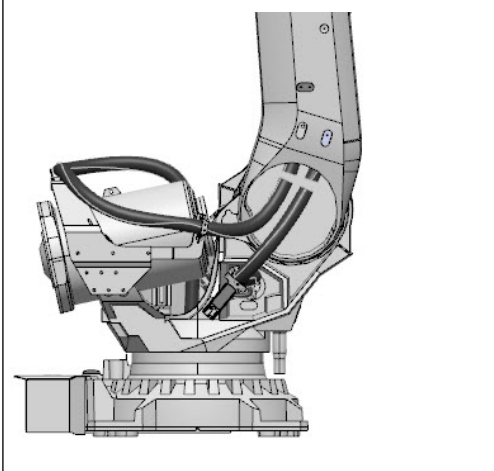
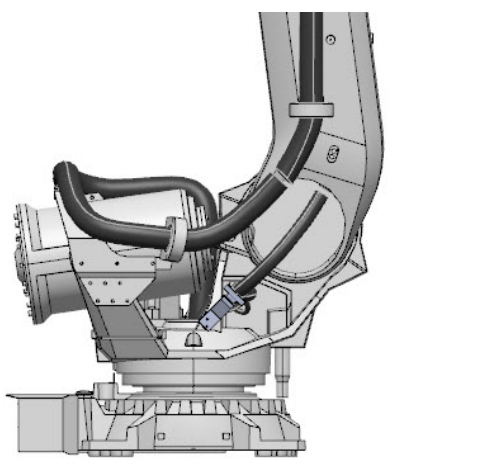
	
Internal routing in lower arm Option 3325-1x, Base to axis 3	External routing Option 3325-1x, Base to axis 3

### 2.2.2 Built-in features for upper arm DressPack

---

#### External

Material handling (option 3326-1x, Axis 3 to axis 6)

- Internal routing through the rear part of the upper arm.
- Protection hose can easily be replaced if damaged.
- One version for all IRB 7600 variants.
- Adjustment for optimal hose/cable lengths.
- Easy exchange of DressPack

---

#### Internal

Material handling (option 3326-3x, Axis 3 to axis 6 (LID)), or spot welding (option 3326-5x/6x, Axis 3 to axis 6 (LID))

- Partly internal routing through the upper arm.
- Suitable for complex movements.
- High demands for flexibility and accessibility.
- Longer life time
- Predictable movements
- Easy exchange of DressPack

## 2 DressPack

### 2.2.3 Interface descriptions for DressPack

### 2.2.3 Interface descriptions for DressPack

#### General

Below is an overview showing the different DressPack options connection points, and their locations. For detailed information see the circuit diagram, and product manual for the manipulator.

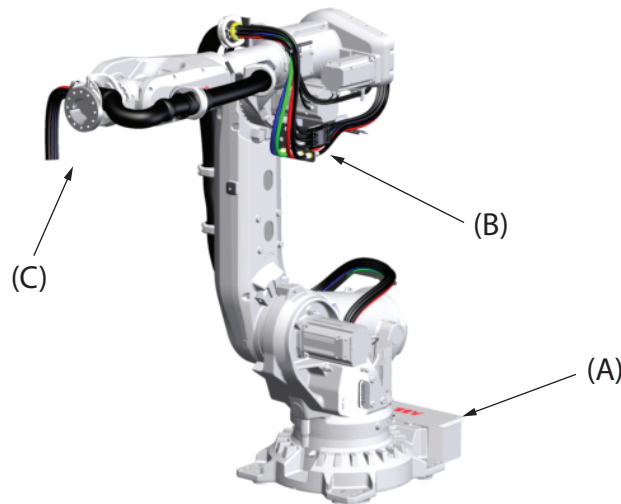

xx1300000224

Pos	Location	Description	Options
A	Base	FB7, CP/CS/CBUS/Ethernet	3325-1x
B	Axis 3	CP/CS/CBUS/Ethernet	3325-1x
C	Axis 6	CP/CS/CBUS/Ethernet, WELD	3326-1x, 3326-3x

#### Base

**Material handling (option 3325-11/12), see figure below:**

- Included are: A, one D (Proc 1).

**Material handling (option 3325-13/14/15), see figure below:**

- Included are: A, E, F and one D.

**Spot welding (option 3325-5x/6x), see figure below:**

- Included are: A, B (if applicable), C, D (Proc 1-4) and E, F (if applicable).

*Continues on next page*

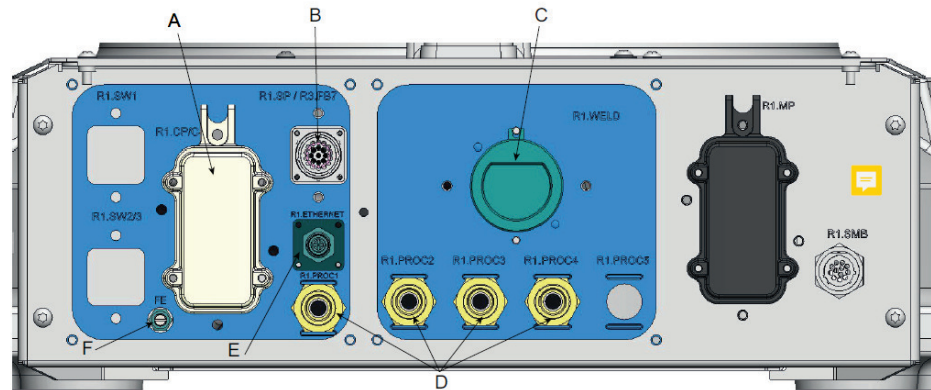

xx1900001501

For corresponding parts of the tool, see [Connector kits on page 79](#).

Pos	Description
A	R1.CP/CS
B	R1.SP (spot welding servo gun) or FB7 (resolver connection)
C	R1.WELD 3x35mm <sup>2</sup> (spot welding)
D	R1.PROC 1 (material handling/spot welding 1/2", M22x1.5, 24 degree seal) R1.PROC 2 - 4 (spot welding 1/2", M22x1.5, 24 degree seal)
E	R1.ETHERNET (M12 connector, when EtherNet communication is selected)
F	FE (functional earth, when EtherNet communication is selected)

### Axis 3

**Material handling (option 3325-11), see figure below:**

- Included are: A and one C (Proc 1).

**Material handling (option 3325-12), see figure below:**

- Included are: A, G and one C (Proc 1).

**Material handling (option 3325-13/14/15), see figure below:**

- Included are: A, G, B, H and one C (Proc 1).

**Spot welding (option 3325-5x/6x), see figure below:**

- Included are: A, D, B/E/F/G/H (if applicable) and C (Proc 1-4).

Continues on next page

## 2 DressPack

### 2.2.3 Interface descriptions for DressPack

Continued

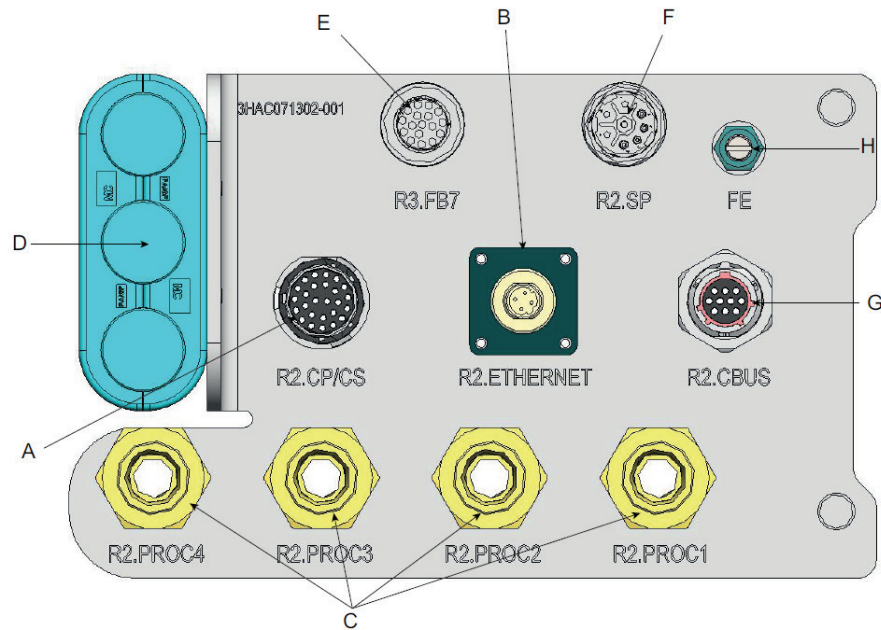

xx1900001511

For corresponding parts of the tool, see [Connector kits on page 79](#).

Pos	Description
A	R2.CP/CS
B	R2.ETHERNET (M12 connector, when EtherNet communication is selected)
C	R2.PROC 1 (material handling 1/2", M22x1.5, 24 degree seal) R2.PROC 2-4 (spot welding 1/2", M22x1.5, 24 degree seal)
D	R2.WELD 3x35mm <sup>2</sup> (spot welding)
E	R2.FB7
F	R2.SP (spot welding servo gun)
G	R2.CBUS (UTOW connector when DeviceNet communication is selected)
H	FE (functional earth, when EtherNet communication is selected)

## Axis 6

### External

**Material handling (option 3326-1x), see figure below:**

- Hose and cable free length, min. 1,000 mm
- Air hose ends with free end.

The cable ends with a connector, the main parts are described in the list below (for corresponding parts of the tool, see [Connector kits on page 79](#)):

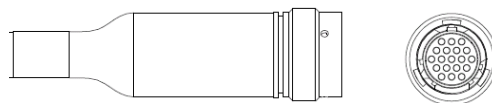

xx0900000728

Continues on next page

## Material handling connector

**Material handling (option 3326-1x)**, see figure below:

- Cable free length, min. 1,000 mm
- Signals are connected with an M12 connector.

The connectors are the same as for option 3326-3x/5x. The difference is the free length of the cables.

Name	Harting article
PIN connector, R3.ETHERNET	21 03 881 1405
PIN	61 03 000 0094



xx1100000956

## Material handling connector (LeanID)

**Material handling option 3326-3x/54/55 (LeanID)**, see figure below:

- Hose and cable free length, min. 1,160 mm
- Hoses with free end.

*Continues on next page*

## 2 DressPack

### 2.2.3 Interface descriptions for DressPack

Continued

The cable ends with connectors, for corresponding parts of the tool, see [Connector kits on page 79](#) and within the UTOW product offer.

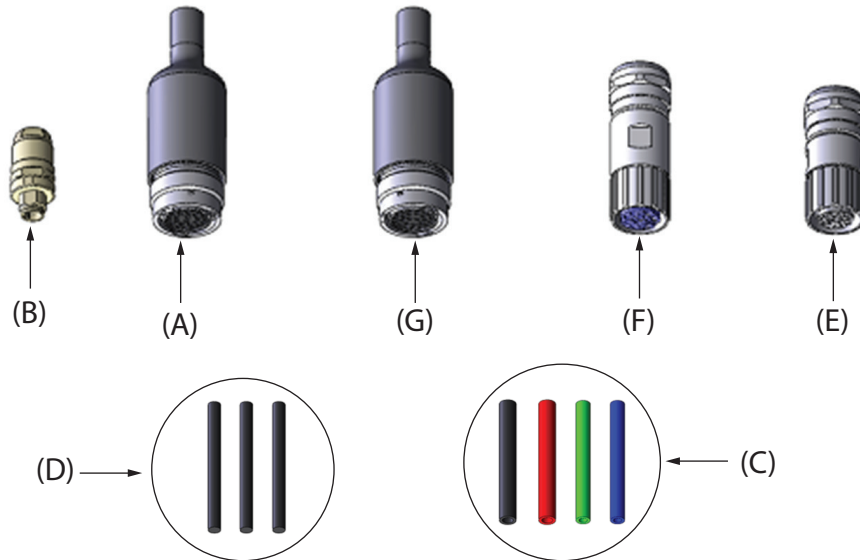

xx1200000117

Pos	Description
A	R3.CP/CS (UTOW connector 26p) Customer signals and power
B	R3.ETHERNET (M12 connector) EtherNet signals (when EtherNet communication is selected)
C	R3.PROC 1-2 (1/2", free end) R3.PROC 2-4 (3/8", free end) Media hoses
D	R3.WELD 3x25mm <sup>2</sup> (free end) Spot Welding power
E	R3.FB7 (M23 connector 17p) Servo motor feedback (when Spot Welding Servo gun is selected)
F	R3.SP (M23 connector 8p) Servo motor power (when Spot Welding Servo gun is selected)
G	R3.CBUS (UTOW connector 10p) BUS signals (when DeviceNet communication is selected)

- FE (M8 cable lug), when Ethernet option 3326-13/33/34/35/54/55 is selected

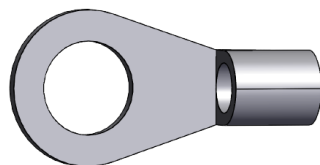

xx2000000109

## 2.2.4 Dimensions

### General

Dimensions are shown in Figures below.

All routing alternatives are shown in the Spot Welding version.

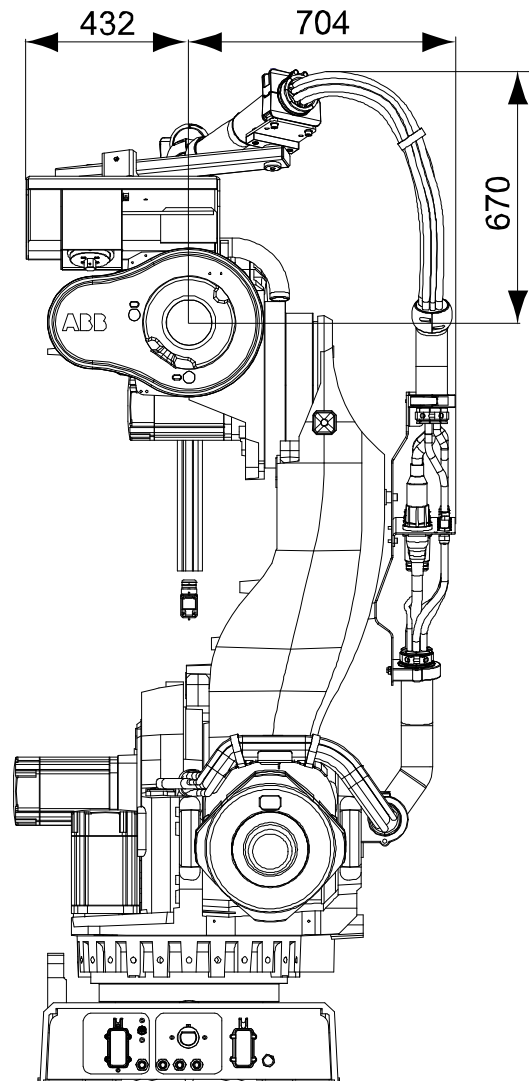

xx100000610

*Continues on next page*

## 2 DressPack

### 2.2.4 Dimensions

Continued

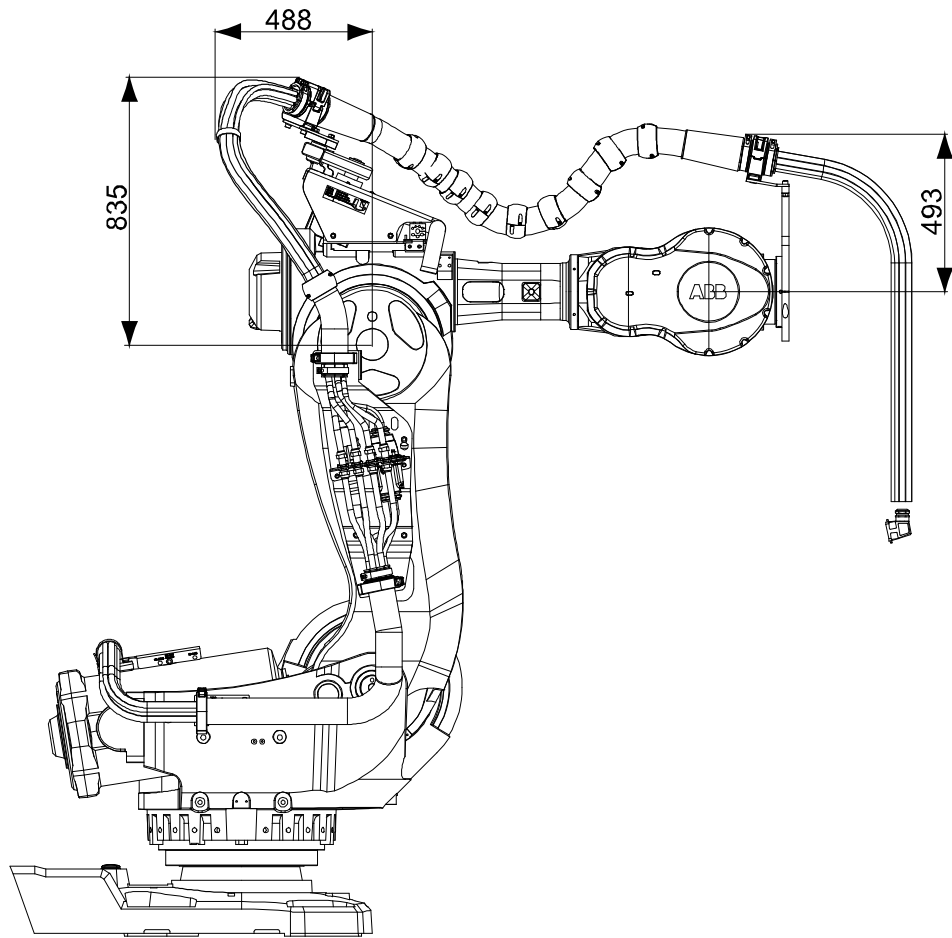

xx100000611

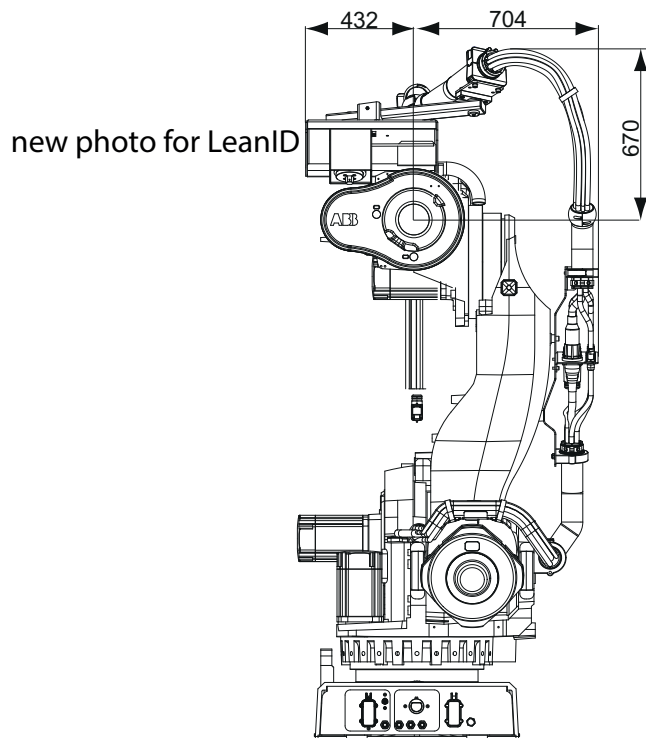

new photo for LeanID

xx150000891

## 2.3 Connector kits

---

### General

The connector kits are described in section [Connector kits manipulator on page 91](#).

**This page is intentionally left blank**

## 3 Specification of variants and options

### 3.1 Introduction to variants and options

---

#### General

The different variants and options for the IRB 7600 are described in the following sections. The same option numbers are used here as in the specification form.

The variants and options related to the robot controller are described in the product specification for the controller.

### 3 Specification of variants and options

#### 3.2 Manipulator

#### 3.2 Manipulator

##### Manipulator variant

Option	Robot variant	Handling capacity (kg)	Reach (m)
3300-89	7600-400/2.55	400	2.55
3300-90	7600-390/2.55 LID	390	2.55
3300-91	7600-340/2.8	340	2.8
3300-92	7600-320/2.8 LID	320	2.8
3300-93	7600-150/3.5	150	3.5
3300-94	7600-500/2.55	500	2.55
3300-95	7600-325/3.1	325	3.1
3300-96	7600-290/3.1 LID	290	3.1

##### Manipulator color

Option	Color	RAL code <sup>i</sup>
209-1	ABB orange standard	NCS 2070-Y60R
209-202	ABB Graphite White std Standard color	RAL 7035
209	RAL code should be specified (ABB non-standard colors)	

<sup>i</sup> The colors can differ depending on supplier and the material on which the paint is applied.



##### Note

The delivery time for painted spare parts is longer for non-standard colors.

##### Manipulator protection

Option	Description
3350-670	Base 67, IP67
3352-10	Foundry Plus2 67, IP67

##### Requirements

The option *Foundry Plus2 67* [3352-10] requires option *Upper arm cover* [3316-1].



##### Note

It is strongly recommended, if Foundry Plus robots in another color than ABB orange is required, that only colors in a yellow nuance are selected, if not the robot can look discolored after a while in the foundry environment. The protection is still preserved in any color.



##### Note

Base 67 includes IP67, according to standard IEC 60529.

*Continues on next page*

#### Foundry cable guard

Option	Description
3315-1	Foundry cable guard

The manipulator can be equipped with additional cable guards for extra tough environmental conditions, for example, metals spits or frequent weld spatter. These additional covers will prolong cable lifetime and simplify service/maintenance as the robot is kept more clean under the covers.

The option *Foundry Cable Guard* is recommended for *Foundry Plus2*.

#### Requirements

The option *Foundry Cable Guard* requires option *Upper arm cover* [3316-1].

#### Foundry cable guards for manipulator cable harness

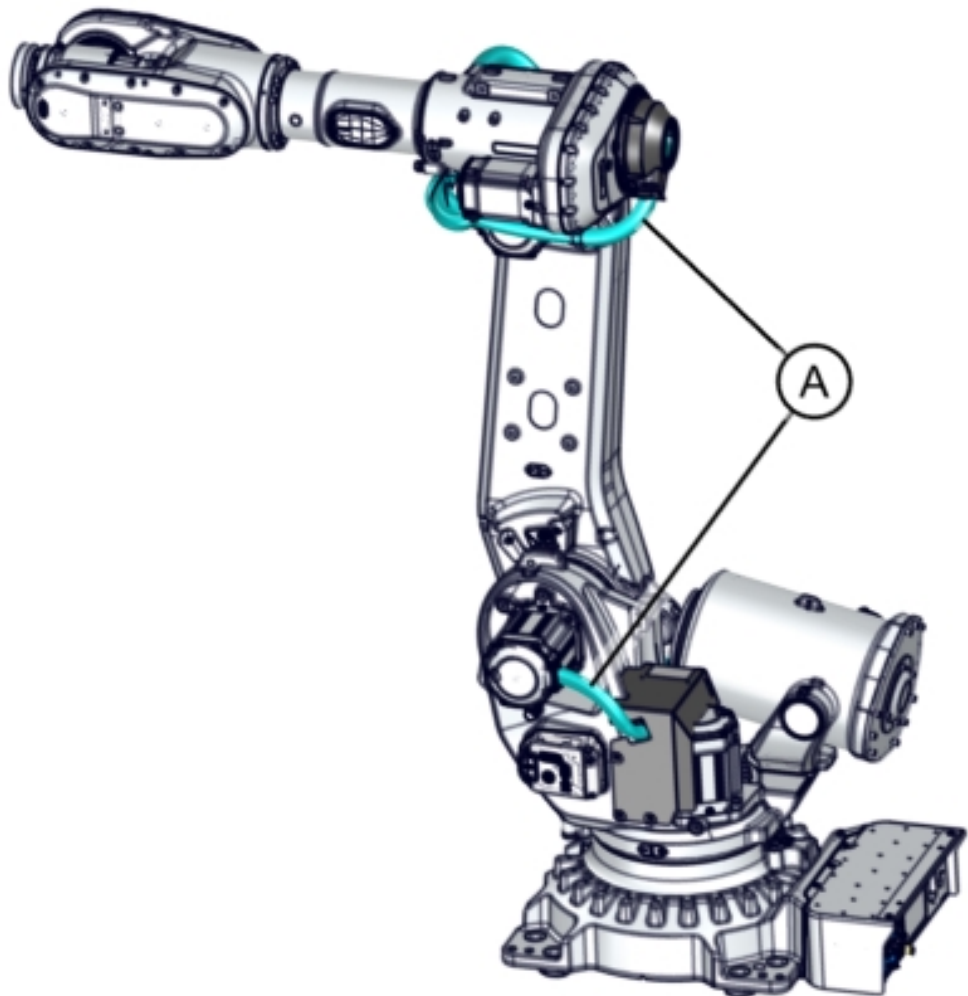

xx2300001724

#### Schematic illustration

A	Foundry cable guard for manipulator cable harness
---	---

Continues on next page

### 3 Specification of variants and options

---

#### 3.2 Manipulator

*Continued*

Foundry cable guard for DressPack

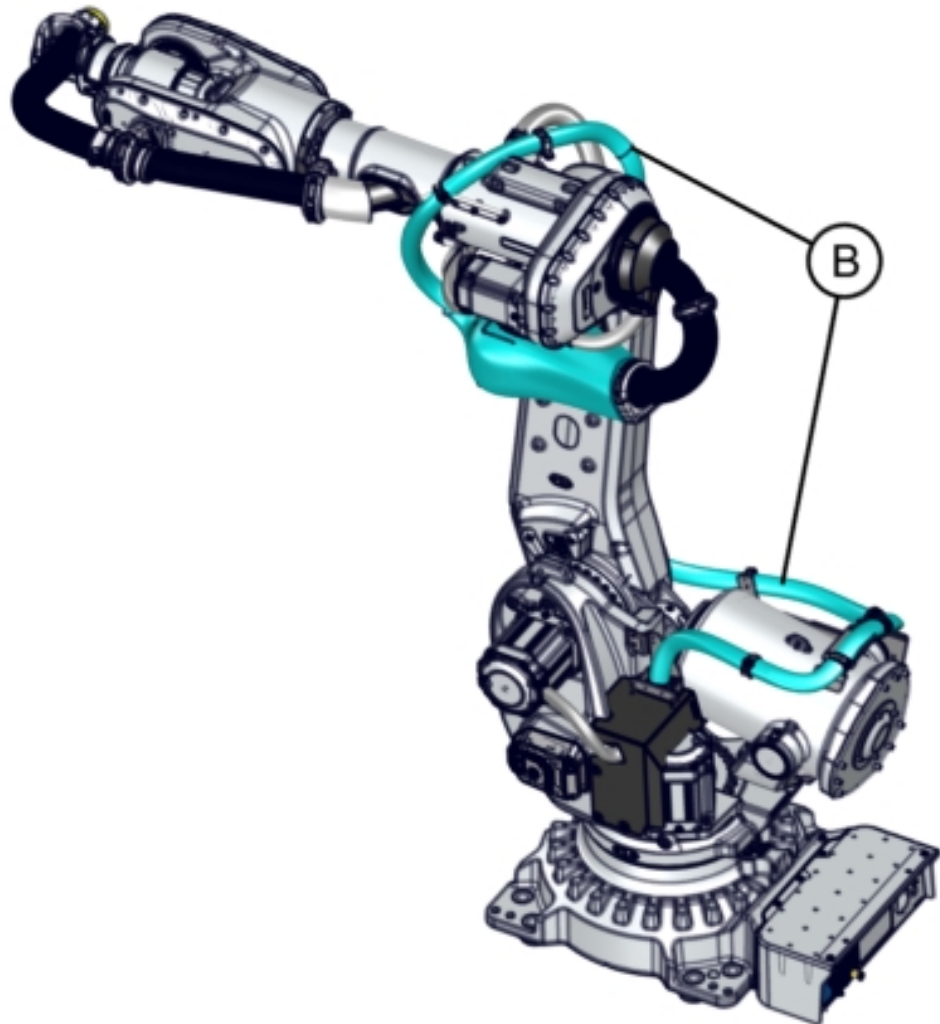

xx2300001725

Schematic illustration

B	Foundry cable guard for DressPack
---	-----------------------------------

---

#### Upper arm cover

Option	Description
3316-1	Upper arm cover

The manipulator can be equipped with additional upper arm covers for environmental conditions, where you want to further seal off the upper arm in wet

*Continues on next page*

or dirty conditions. These additional covers will prolong the lifetime of the cables, and simplify service/maintenance as the robot is kept more clean under the covers.



xx2100002592

#### Requirements

This option is mandatory to order with the option *Foundry Plus2* [3352-10].

This option is mandatory to order with the option *Foundry Cable Guard* [3315-1].

This option is mandatory to order with the option *DressPack axis 3-6* [3326-x].

#### Forklift device

The manipulator can be delivered with forklift devices, allowing a forklift to be used when moving the manipulator.

Option	Description	
3318-2	Forklift device on frame Fork lift pockets placed on the frame gives a more balanced lifting point. This can be used together with special tool to invert a robot.	<p>xx2300001243</p>

#### Motor cooling

To be used to avoid overheating of motors and gears in applications with intensive motion (high average speed and/or high average torque and/or short wait time) of the axes on the lower arm.

Option	Description
3320-1	Cooling fan axis 1
3321-1	Cooling fan axis 2

The cooling fan has protection class IP54.

*Continues on next page*

### 3 Specification of variants and options

#### 3.2 Manipulator

*Continued*

To determine the need of cooling fans on the motors, use the add-in **Mechanical Analysis** in RobotStudio. For more information, contact your local ABB office.

#### Limitations

Cannot be combined with track motion.

#### Resolver connection 7th axis

Option	Description
3322-1	On base
3322-2	In servo DressPack This option is required for the option 3325-x DressPack base-axis 3 including servo.

Option 3222-2 In servo DressPack adds a connection point for the 7th axis servo feedback on the frame of the robot to be used in servo DressPack.

#### Limited working range

Option	Description
3323-1	Axis 1 adjustable 15°
3323-3	Axis 1 adjustable 7.5°

The manipulator can be equipped with adjustable mechanical stops. This is to mechanically limit the working range on axis 1. The mechanical stops are delivered alongside the robot (not installed). The stops can be placed in steps according to the option.

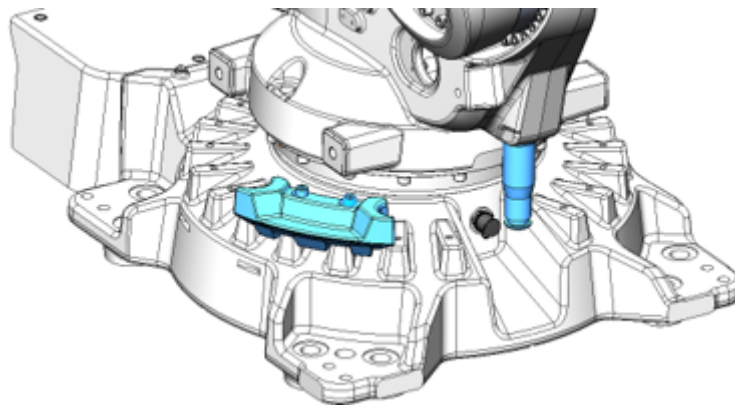

xx2100002595

#### Extended working range

Option	Description	
3324-1	Axis 1 to $\pm 220^\circ$	The option extends the working range on axis 1 from $\pm 170^\circ$ to $\pm 220^\circ$ .

*Continues on next page*



### CAUTION

The option *Extended work range* enables an extension of the working range for axis 1, through a software configuration. With this option installed, the working range can exceed the range limited by the mechanical stop on axis 1. The working range shall be limited through the option *SafeMove*.

A risk analysis must be done to ensure that no risks remain when using option *Extended work range*, to limit the working range, and before removing the mechanical stops.

For information about the option *SafeMove*, see *Application manual - Functional safety and SafeMove*.

If the mechanical stop is removed, then the manipulator should have a marking for this, for example, a label. If the robot is delivered with the option *Extended work range*, then such a label is included on delivery.

### Requirements

This option requires the option *SafeMove* [3043-x].

## 3 Specification of variants and options

---

### 3.3 Floor cables

### 3.3 Floor cables

---

#### Manipulator cable length

Option	Lengths
3200-2	7 m
3200-3	15 m
3200-4	22 m
3200-5	30 m

#### 3.4 Application manipulator

##### DressPack base-axis 3

Option	Description	Additional information
3325-11	MH Parallel	
3325-12	MH DeviceNet	Includes parallel signals
3325-13	MH EtherNet	Includes parallel signals. Supports ProfiNet, EtherNetIP
3325-14	MH CC Link	Includes parallel signals
3325-15	MH EtherCat	Includes parallel signals
3325-51	SW Parallel	
3325-52	SW DeviceNet	Includes parallel signals
3325-53	SW EtherNet	Includes parallel signals. Supports ProfiNet, EtherNetIP
3325-54	SW CC Link	Includes parallel signals
3325-55	SW EtherCat	Includes parallel signals
3325-61	SW Parallel-Servo	
3325-62	SW DeviceNet-Servo	Includes parallel signals
3325-63	SW EtherNet-Servo	Includes parallel signals. Supports ProfiNet, EtherNetIP
3325-64	SW CC Link-Servo	Includes parallel signals
3325-65	SW EtherCat-Servo	Includes parallel signals

##### DressPack axis 3-6

Option	Description	Additional information
3326-11	MH3 Parallel	
3326-12	MH3 DeviceNet	Includes parallel signals
3326-13	MH3 EtherNet	Includes parallel signals. Supports ProfiNet, EtherNetIP
3326-14	MH3 CC Link	Includes parallel signals
3326-15	MH3 EtherCat	Includes parallel signals
3326-31	MH LID Parallel	
3326-32	MH LID DeviceNet	Includes parallel signals
3326-33	MH LID EtherNet	Includes parallel signals. Supports ProfiNet, EtherNetIP
3326-34	MH LID CC Link	Includes parallel signals
3326-35	MH LID EtherCat	Includes parallel signals
3326-51	SW LID Parallel	
3326-52	SW LID DeviceNet	Includes parallel signals
3326-53	SW LID EtherNet	Includes parallel signals. Supports ProfiNet, EtherNetIP

*Continues on next page*

### 3 Specification of variants and options

---

#### 3.4 Application manipulator

*Continued*

Option	Description	Additional information
3326-54	SW LID CC Link	Includes parallel signals
3326-55	SW LID EtherCat	Includes parallel signals
3326-61	SW LID Parallel-Servo	
3326-62	SW LID DeviceNet-Servo	Includes parallel signals
3326-63	SW LID EtherNet-Servo	Includes parallel signals. Supports ProfiNet, EtherNetIP
3326-64	SW LID CC Link-Servo	Includes parallel signals
3326-65	SW LID EtherCat-Servo	Includes parallel signals

### 3.5 Connector kits manipulator

#### General

Below is an example of how a connector kit and its parts can look like.



xx130000223

*Continues on next page*

### 3 Specification of variants and options

#### 3.5.1 Base - Connector kits

#### 3.5.1 Base - Connector kits

##### Available options

Option	Name	DressPack options		
		3325-1x	3325-5x	3325-6x
3330-2	CP/CS, Proc 1 base	X	X	
3331-1	Weld Proc 2-4 base		X	X
3332-1	FB7 on base			



##### Note

Servo power connection kits are not available.

##### Option CP/CS, Proc 1 on base - 3330-2

R1. CP/CS and Proc 1 on base

This option offers a kit with connectors. This must be assembled by the customer.

The kit contains:

- 1 Hose fittings (swivel nut adapter, (1/2", M22x1.5 Brass, 24 degree seal))
- Connector with:

1 pcs Hood Foundry (Harting)	HAN EMC / M 40
1 pcs Hinged frame (Harting)	Shell size 16
2 pcs Multicontact, female (Harting)	Type HD (25 pin)
1 pcs Multicontact, female (Harting)	Type DD (12 pin)
1 pcs Multicontact, female (Harting)	Type EE (8 pin)
10 pcs Female crimp contacts	For 1.5 mm <sup>2</sup>
10 pcs Female crimp contacts	For 0.5 mm <sup>2</sup>
10 pcs Female crimp contacts	For 1.0 mm <sup>2</sup>
10 pcs Female crimp contacts	For 2.5 mm <sup>2</sup>
12 pcs Female crimp contacts	For 0.14 - 0.37 mm <sup>2</sup>
45 sockets	For 0.2 - 0.56 mm <sup>2</sup>
Assembly Accessories to complete connector	
Assembly instruction	

##### Option Weld Proc 2-4 base - 3331-1

This option offers a kit with connectors. This must be assembled by the customer.

The kit contains the following components.

##### WELD

Amount	Description	Size, material, etc.	Brand
1	Welding connector socket	TSB150/L-UR	Stäubli
3	Socket	For 35 mm <sup>2</sup>	

*Continues on next page*

### 3 Specification of variants and options

#### 3.5.1 Base - Connector kits

*Continued*

Amount	Description	Size, material, etc.	Brand
1	Form shroud welding conn.	202K174-3/42-0, for cable diameter 15.7-35 mm	Raychem

Media

Amount	Description	Size, material, etc.	Brand
4	Hose coupling	1/2", M22 x 1.5 Brass	

#### Option FB7 on base - 3332-1

R3. FB 7 on base

This option offers a kit with a connector. This must be assembled by the customer.

The kit contains:

- Connector with:

1 pcs Multiple connector (pin)	UTOW
1 pcs Adapter	8 pin
8 pcs Pin	For 0.13 - 0.25 mm <sup>2</sup>
Assembly Accessories to complete connector	
Assembly instruction	

### 3 Specification of variants and options

#### 3.5.2 Axis 3 - Connector kits

#### 3.5.2 Axis 3 - Connector kits

##### Available options

		DressPack options	Description
Option	Name	3325-1x	
3333-2	CP/CS bus, Proc 1 axis 3	X	UTOW
3334-3	CP/CS Proc1, Servo & FB		

##### Option CP/CS/CBus, Proc 1 axis 3 - 3333-2

CP/CS/CBus, Proc 1 axis 3 on tool side for option 3326-1x and 3326-3x.

This kit offers a kit with connectors to be mounted at toolside of axis 3.

This must be assembled by the customer.

The kit contains:

- 1 Hose fitting (Parker Push lock (1/2", M22x1.5 Brass, 24 degree seal))
- Connector with:

CP/CS	
1 pcs UTOW Pin connector 26p, bayonet	UTOW61626PH, Shell size 16
26 pcs Pin	RM18W3K, 0.5-0.82 mm <sup>2</sup>
CBUS	
1 pcs UTOW Pin connector 10p, bayonet	UTOW61210PH, Shell size 12
10 pcs Pin	RM18W3K, 0.5-0.82 mm <sup>2</sup>
Ethernet	
1 pcs Pin connector M12	Harting 21 03 881 1405
4 pcs Pin	Harting 09670005576, 0.13-0.33 mm <sup>2</sup>

##### Option CP/CS Proc1, Servo & FB - 3334-3

SP (Servo Power)	
1 pc Straight connector M23 8p	
4 pcs Crimp pin 1 mm	AWG 24-17
4 pcs Crimp pin 2 mm	AWG 18-14
SS (Servo Signal)	
1 pcs Straight connector M23 17p	
17 pcs Pin	AWG 28-20
Assembly Accessories to complete connector	
Assembly instruction	

### 3.5.3 Axis 6 - Connector kits

#### Available options

		DressPack options	DressPack options	Description
Option	Name	3326-1x	3326-3x	
3334-2	CP/CS bus axis 6	X	X	UTOW
3334-3	CP/CS Proc1, Servo & FB			
3335-1	Weld Proc 2-4 axis 6			

#### Option CP/CS/CBus, Proc 1 axis 6 - 3334-2

CP/CS/CBus/SP/SS, Proc 1 axis 6 on tool side for option 3326-1x and 3326-3x.

This kit offers a kit with connectors to be mounted at tool side of axis 6.

This must be assembled by the customer.

The kit contains:

- 1 Hose fitting (swivel nut adapter (1/2", M22x1.5 Brass, 24 degree seal))
- Connector with:

CP/CS	
1 pcs UTOW Pin connector 26p, bulkhead	UTOW71626PH05, Shell size 16
26 pcs Pin	RM18W3K, 0.5-0.82 mm <sup>2</sup>
CBUS	
1 pcs UTOW Pin connector 10p, bulkhead	UTOW71210PH05, Shell size 12
10 pcs Pin	RM18W3K, 0.5-0.82 mm <sup>2</sup>
Ethernet	
1 pcs Socket connector M12	Harting 21 03 881 2425
4 pcs Socket	Harting 09670005476, 0.13-0.33 mm <sup>2</sup>

#### Option CP/CS Proc1, Servo & FB - 3334-3

SP (Servo Power)	
1 pcs Bulkhead contact M23	
4 pcs Crimp pin 1 mm	AWG 24-17
4 pcs Crimp pin 2 mm	AWG 18-14
SS (Servo Signal)	
1 pcs Bulkhead contact M23	
17 pcs Pin	AWG 28-20
Assembly Accessories to complete connector	
Assembly instruction	

*Continues on next page*

### 3 Specification of variants and options

---

#### 3.5.3 Axis 6 - Connector kits

*Continued*

---

#### Option Weld Proc 2-4 axis 6 - 3335-1

Weld and Proc 2-4 axis 6 on manipulator side for option 3335-1

The process cable package from axis 6 ends with free end for media and for weld power cable. The option offers a kit for connectors. This must be assembled by the customer when hoses and power cable has been cut to required length.

The kit contains:

- 4 Hose fittings (Swivel Nut adapter, (2 x 1/2", M22x1.5) and (2x 3/8", M16x1.5))
- 1 Multi contact connector (Female) type including:

• 1 pc Welding connector	3x25 mm <sup>2</sup>
1 pc Cable gland	Diameter 24-28 mm
1 pc End housing	0.21-0.93 mm <sup>2</sup>
1 pcs Reducing coupling	PG36/PG29
Assembly Accessories to complete connector	
Assembly instruction	

### 3.6 Application floor cables

#### Parallel cable - Length

Option	Description	Note
3201-2	7 m	
3201-3	15 m	
3201-4	22 m	
3201-5	30 m	

#### Ethernet cable - Length



#### Note

Occupies 1 Ethernet port.

Option	Description	Note
3202-2	7 m	Includes Parallel cable
3202-3	15 m	Includes Parallel cable
3202-4	22 m	Includes Parallel cable
3202-5	30 m	Includes Parallel cable

#### DeviceNet cable - Length

Option	Description	Note
3204-2	7 m	Includes Parallel cable
3204-3	15 m	Includes Parallel cable
3204-4	22 m	Includes Parallel cable
3204-5	30 m	Includes Parallel cable

#### CC-Link cable - Length

Option	Description	Note
3205-2	7 m	Includes Parallel cable
3205-3	15 m	Includes Parallel cable
3205-4	22 m	Includes Parallel cable
3205-5	30 m	Includes Parallel cable

#### Servo cable 1 axis - Length

Option	Description	Note
3206-2	7 m	
3206-3	15 m	
3206-4	22 m	
3206-5	30 m	

*Continues on next page*

### 3 Specification of variants and options

---

#### 3.6 Application floor cables

*Continued*

---

#### EtherCat cable - Length



#### Note

Occupies 1 Ethernet port.

Option	Description	Note
3210-2	7 m	Includes Parallel cable
3210-3	15 m	Includes Parallel cable
3210-4	22 m	Includes Parallel cable
3210-5	30 m	Includes Parallel cable

---

#### MCB Servo cable 1 axis

Option	Description	Note
3212-2	7 m	

#### Requirements

This option requires options DressPack base-axis 3 and Motor Connection Kit [3069-x].

3.7 Warranty

Warranty

For the selected period of time, ABB will provide spare parts and labor to repair or replace the non-conforming portion of the equipment without additional charges. During that period, it is required to have a yearly *Preventative Maintenance* according to ABB manuals to be performed by ABB. If due to customer restrains no data can be analyzed with ABB Connected Services for robots with OmniCore controllers, and ABB has to travel to site, travel expenses are not covered. The *Extended Warranty* period always starts on the day of warranty expiration. Warranty Conditions apply as defined in the *Terms & Conditions*.



Note

This description above is not applicable for option *Stock warranty* [438-8]

Option	Type	Description
438-1	Standard warranty	Standard warranty is 12 months from <i>Customer Delivery Date</i> or latest 18 months after <i>Factory Shipment Date</i> , whichever occurs first. Warranty terms and conditions apply.
438-2	Standard warranty + 12 months	Standard warranty extended with 12 months from end date of the standard warranty. Warranty terms and conditions apply. Contact Customer Service in case of other requirements.
438-4	Standard warranty + 18 months	Standard warranty extended with 18 months from end date of the standard warranty. Warranty terms and conditions apply. Contact Customer Service in case of other requirements.
438-5	Standard warranty + 24 months	Standard warranty extended with 24 months from end date of the standard warranty. Warranty terms and conditions apply. Contact Customer Service in case of other requirements.
438-6	Standard warranty + 6 months	Standard warranty extended with 6 months from end date of the standard warranty. Warranty terms and conditions apply.
438-7	Standard warranty + 30 months	Standard warranty extended with 30 months from end date of the standard warranty. Warranty terms and conditions apply.
438-8	Stock warranty	<p>Maximum 6 months postponed start of standard warranty, starting from factory shipment date. Note that no claims will be accepted for warranties that occurred before the end of stock warranty. Standard warranty commences automatically after 6 months from <i>Factory Shipment Date</i> or from activation date of standard warranty in WebConfig.</p> <div data-bbox="826 1800 888 1861" data-label="Image"> </div> <div data-bbox="909 1814 976 1845" data-label="Section-Header"> <p>Note</p> </div> <div data-bbox="821 1868 1452 1926" data-label="Text"> <p>Special conditions are applicable, see <i>Robotics Warranty Directives</i>.</p> </div>

Continues on next page

### 3 Specification of variants and options

---

#### 3.7 Warranty

*Continued*

---

#### Warranty for DressPack



#### Note

Option 3326-11/13 upper arm DressPack MH3 is not covered by the warranty.

# Index

## A

Absolute Accuracy, 30  
Absolute Accuracy, calibration, 28  
ambient humidity  
  operation, 20  
  storage, 20  
ambient temperature  
  operation, 20  
  storage, 20

## C

calibration  
  Absolute Accuracy type, 27  
  standard type, 27  
calibration, Absolute Accuracy, 28  
Calibration Pendulum, 29  
CalibWare, 27  
category 0 stop, 64  
category 1 stop, 64  
compensation parameters, 30

## D

DressPack warranty, 100

## E

extended working range, 87

## F

fine calibration, 29  
foundation  
  requirements, 20

## H

humidity  
  operation, 20  
  storage, 20

## L

loads on foundation, 19

## O

operating conditions, 20  
option  
  Extended working range, 87  
options, 81

## P

product standards, 16  
protection classes, 21  
protection type, 21

## R

requirements on foundation, 20  
robot  
  protection class, 21  
  protection types, 21

## S

safety standards, 16  
standards, 16  
standard warranty, 99  
stock warranty, 99  
stopping distances, 64  
stopping times, 64  
storage conditions, 20

## T

temperatures  
  operation, 20  
  storage, 20  
torques on foundation, 19

## V

variants, 81

## W

warranty, 99  
warranty for DressPack, 100  
weight, 18







**ABB AB**

**Robotics & Discrete Automation**

S-721 68 VÄSTERÅS, Sweden

Telephone +46 10-732 50 00

**ABB AS**

**Robotics & Discrete Automation**

Nordlysvegen 7, N-4340 BRYNE, Norway

Box 265, N-4349 BRYNE, Norway

Telephone: +47 22 87 2000

**ABB Engineering (Shanghai) Ltd.**

Robotics & Discrete Automation

No. 4528 Kangxin Highway

PuDong New District

SHANGHAI 201319, China

Telephone: +86 21 6105 6666

**ABB Inc.**

**Robotics & Discrete Automation**

1250 Brown Road

Auburn Hills, MI 48326

USA

Telephone: +1 248 391 9000

**[abb.com/robotics](http://abb.com/robotics)**