

# Paramatised process control

by **Martin Knabenhans,**  
**ABB, Switzerland**

*ABB's System 800xA Minerals Library is a suite of object-oriented software control modules which make it possible to design process control and power applications in an efficient and fully-parameterised fashion. Successfully operating at more than 300 cement and minerals sites worldwide, ABB state that the technology increases the standardisation, functionality and quality of process control software over the complete life cycle of a production facility. This minimises downtime caused by abnormal situations and allows the facility's production process and assets to be efficiently operated and maintained.*

In process control applications, software is traditionally designed using function blocks that are interconnected by various single information variables. In such designs, the interfacing between the function blocks does not follow a set pattern but is left to the discretion of the programmer. Even if the function blocks have been tested and approved, the code between the blocks allows plenty of room for error and inconsistency in the coding and behaviour of the software.

Consequently, it takes a system specialist to interpret the software's control strategies. Since the interface between the function blocks is not predefined, the potential of a library upgrade to deliver improvements is limited to the function blocks only: it does not enhance the important code between the blocks.

### A new way of thinking

The first concepts on how to simplify the interface between group/sequence function blocks and motor/valve function blocks were developed in the late-1990s. At that time, however, the available

technology in the process controllers was not sufficiently advanced to allow the concept's implementation. This changed when ABB introduced its fully object-oriented Extended Automation System 800xA control platform, making it possible to develop and implement a complete new library concept using parameterisation and an innovative approach to data exchange called 'control connections.'

### Control connections

In this concept, all software modules exchange data through defined interfaces called control connections. A control connection is a logical connection between a 'parent' object and as many 'child' objects as required. It is a data highway over which all the information defined for exchange between a parent object and its child objects is submitted. The communication is bi-directional, enabling parent objects to send commands and



Figure 1: Jura Cement's facility at Wildegg, Switzerland, is one of more than 300 cement and minerals processing plants that benefit from ABB's parameterised and object-oriented process control solutions

Figure 2: traditional single information connections between group/sequence & process equipment

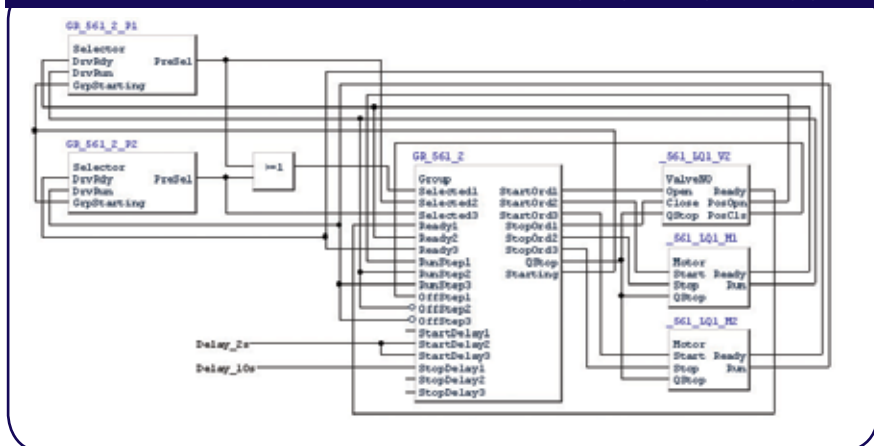

Figure 3: principle of the control connection data highway between objects

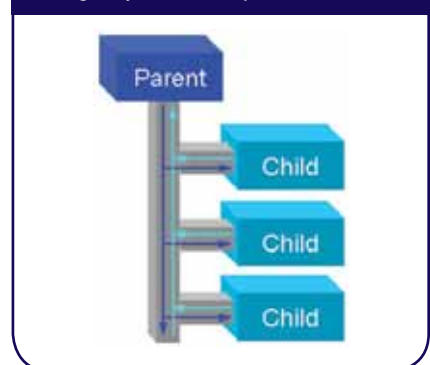
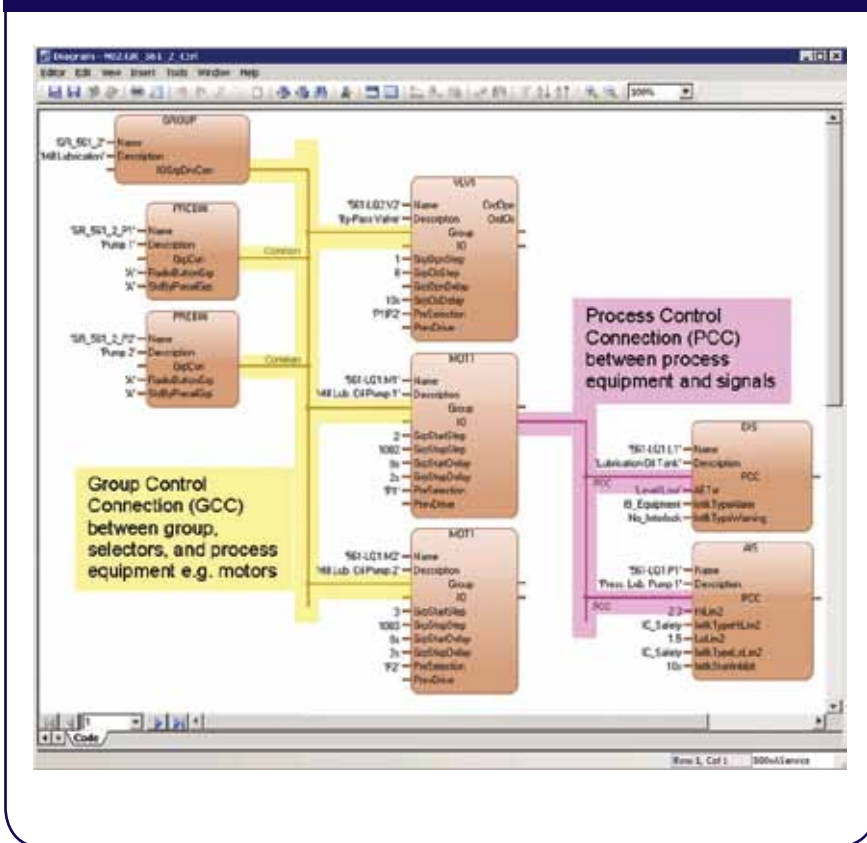

Figure 4: system 800xA control connections and parameters for group/sequence and interlock control. The example shows the configuration of two redundant lubrication pumps



**Functionality**

Today, System 800xA Minerals Library covers the following three functional areas:

- group/sequence control (GCC)
- process equipment interlocking (PCC)
- electrical energy management.

**Group/sequence control**

In cement, mining and minerals applications, group control – like the sequential or cyclic start and stop of process equipment including routing and duty standby – is essential. ABB’s System 800xA Minerals Library provides the following fully parameterised functions:

- group control modules for continuous or cyclic processes
- unlimited number of process equipment items per group (motors, valves, actuators, loops)
- starting and stopping of all process equipment according to the parameterised sequence
- selector modules for parameterised routing and duty standby applications
- connection of process equipment to several groups (several parents for one child)
- summary status (run, warning, failure, etc) from connected process equipment visible in the group header process graphic and faceplate
- first fault detection – the tag of the process equipment causing the group to fail is presented in the group faceplate, including a hyperlink to navigate directly to the faulty equipment
- all key parameters like group name, step numbers, start and stop delay as well as routing information is visible in the faceplate of each item of process equipment
- the group status viewer presents detailed

retrieve status information from child objects and vice versa. The amount of information exchanged over the inherited control connections interface is changeable in runtime.

**Parameterisation**

Once ABB had designed the communication interface between software modules, the next step was to capture the functionality that was traditionally programmed with code between the function blocks. ABB Minerals has put much effort into the systematic analysis of typical cement and minerals processing application programme solutions and operational situations. The captured results have been used to develop generic parameterised functions.

As a result of this process, the System 800xA Minerals Library comprises a comprehensive set of software modules which make it possible to design process control applications simply by parameterising well-test software modules. The readability of the application code has become much easier, enabling operators and process engineers to understand the control solution and improve it when required.

Figure 5: example of a process graphic display showing one group and all related equipment

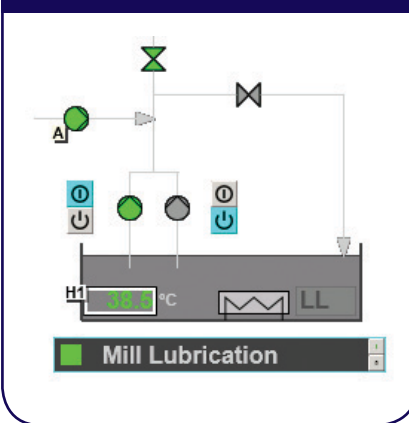

Figure 6: group status viewer presenting one group and all related process equipment

Object Name	Description	Type	Status	Alarm	Control	Mode	Step	PreSelection
GR_561_2	Mill Lubricator	GROUP	Run		Central	Man		
GR_561_2_P1	Pump 1	PREBIN	Selected					
GR_561_2_P2	Pump 2	PREBIN	Standby					
561-LQ2.V2	BP VALVE	VVLV1	PosY		Sequence	Man	1	P1 P2
561-LQ1.M1	OIL PUMP 1	MOT1	Run		Sequence	Man	2	P1
561-LQ1.M2	OIL PUMP 2	MOT1	Off		Sequence	Man	3	P2
561-LQ1.H1	OIL HEATER	MOT1	Off		Sequence	Auto	4	P1 P2
561-LQ1.M3	COOLING FAN	MOT1	Off		Sequence	Auto	5	P1 P2
561-LQ1.V1	MAIN VALVE	VVLV1	PosX		Sequence	Man	7	P1 P2

information of the group and all connected process equipment including start order and routing information.

The concept allows users to add, remove or change the start/stop order as well as the routing of the process equipment in runtime. The group status viewer automatically updates as soon as the changes are loaded into the process controller. Thus, the operator gets reliable, up-to-date and easy to understand information on the status and behaviour of all groups.

**Process equipment interlocking**

Much of the process equipment in the heavy industry market requires interlocking signals for human and machine safety or process control. Traditionally, the interlock code that was programmed between the digital and analogue signal function blocks and the process equipment function blocks (motors and valves, etc) was not or only partly visible to operators and process engineers. The non-availability of this information makes it difficult to operate the plant in an efficient and safe manner.

The parameterised interlock concept of the System 800xA Minerals Library closes this gap and at the same time simplifies

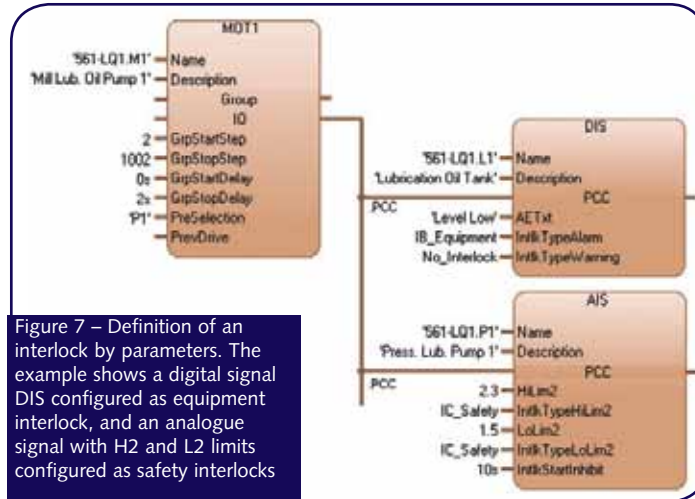

Figure 7 – Definition of an interlock by parameters. The example shows a digital signal DIS configured as equipment interlock, and an analogue signal with H2 and L2 limits configured as safety interlocks

plant operations. All the interlocking signals for each item of process equipment are connected to the interlocking control connection. The parameters of the signal software modules allow configuration of the required interlock behaviour. Functions include:

- analogue and digital input signals, as well as PID loop controller modules, provide parameters for the configuration of the control interlock and automatic process start/stop of one or several items of process equipment
- unlimited number of signals per item of process equipment
- signals read the process equipment status (on, off, local operation,

maintenance, etc) to execute the required alarm and start the inhibit function

- first fault detection and suppressing of unnecessary subsequent alarms
- automatic indication of the signal tag causing a failure in the process equipment faceplate, including a hyperlink to navigate directly from the process equipment to the faulty signal
- all key parameters like

threshold limit, warning and failure delay, interlock type, local operation override and start inhibit time are visible in the faceplate of each signal

- the interlock viewer presents detailed information of all signals controlling the equipment. Beside the actual status (no interlock, warning or failure), the viewer informs the operator on temporary overrides made for maintenance or abnormal situations.

The concept allows users to add, remove or change interlocks in runtime. The interlock viewer automatically updates as soon as the changes are loaded into the process controller. Thus, the operator receives reliable, up-to-date, and easy to understand information on all interlocks.

**Electrical energy management**

Integration of the power distribution monitoring and management systems into the plant control system is becoming more and more important in today's liberalised energy markets.

The ABB System 800xA Minerals Library is equipped with object-oriented software modules for the following electrical applications:

- circuit breaker control
- power factor correction
- energy, power and tariff limit scheduler, including overrun warning and load shedding.

In combination with System 800xA's comprehensive communication capabilities – which include Ethernet-based protocols, IEC 61850, Modbus TCP/IP and Profinet IO – the power and process automation systems not only run in one single system but are covered by one common software module library as well.

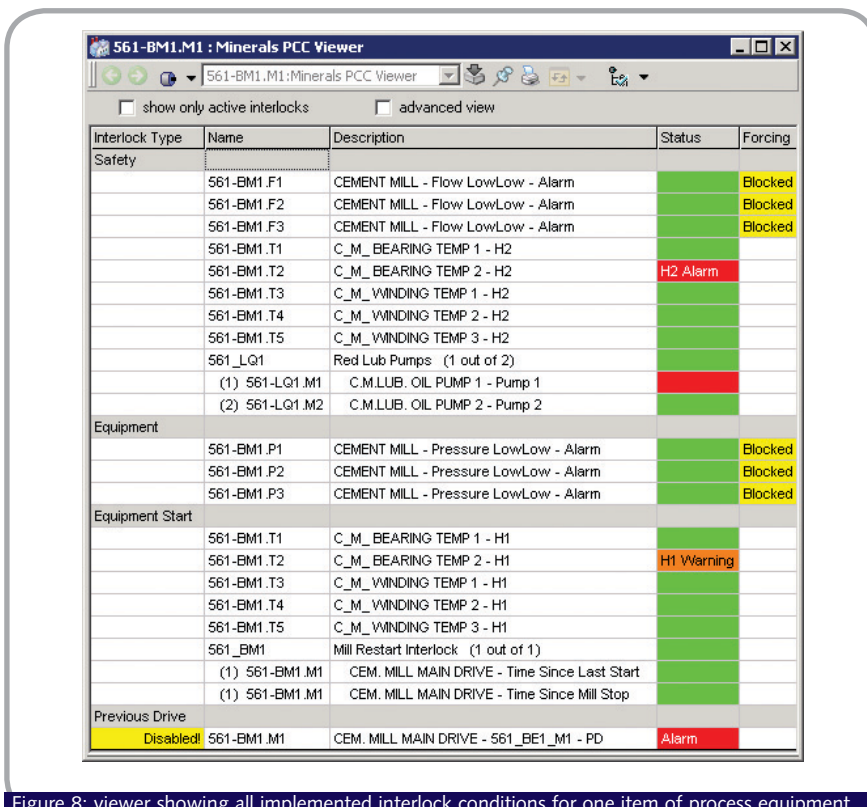

Figure 8: viewer showing all implemented interlock conditions for one item of process equipment

Figure 9: integrated electrical energy monitoring and management



Figure 10: relative engineering effort required per method of implementation

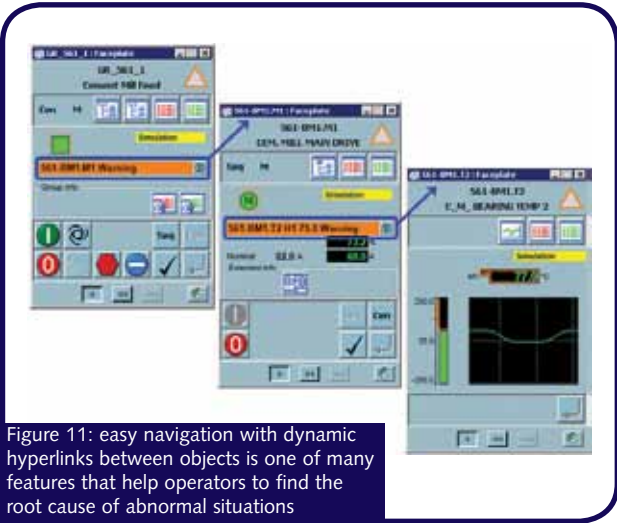
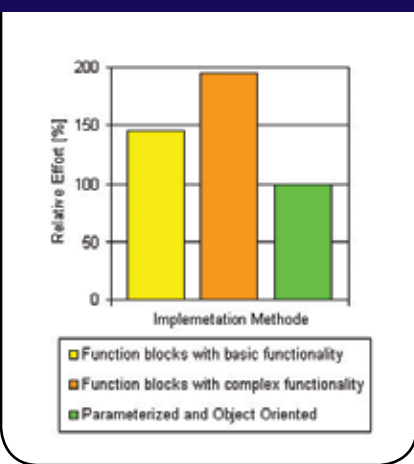

Figure 11: easy navigation with dynamic hyperlinks between objects is one of many features that help operators to find the root cause of abnormal situations

**Operation**

- Consistent, flexible and proven operation concept
- Indication by colour, shape and labels instead of by colour only
- Display design focuses attention on abnormal situations
- Alarm management and abnormal situation monitoring
- Alarm list messages may be suppressed in case:

**Benefits**

Fully parameterised object-oriented application software provides significant benefits over the complete life cycle of the plant.

**Engineering, testing and commissioning**

- objects with defined two-way interfaces reduce the engineering effort
- parameterised group start/stop/routing/changeover
- parameterised safety, equipment and process interlocks
- reduction of individual code between objects to 10 per cent of a traditional application software
- increased quality and structure of application software
- powerful graphics library for easy implementation of a consistent and ergonomic look and feel
- reduced risk thanks to proven software modules with known behaviour
- powerful testing and simulation with built-in simulation on soft controller
- improved commissioning time.

- the parent object is off – alarm on active parent only
- the parent object is starting up – start-up alarm inhibit
- the parent object is in local control mode – auto acknowledge in local operation mode
- first fault and highest priority alarm detection and forwarding to consumer and group
- Automatic reduction of alarm severity for consumers defined as standby
- Good diagnostic functions presenting objects and their relation for fast and correct decisions
- Dynamic hyperlinks between parent and child faceplates
- Group status viewer
- Interlock viewer

- Operator training with built-in simulation.

**Maintenance**

- Extensive alarm, event, tracking and trending functionalities.
- Group status and interlock viewer
- Device diagnostic viewers – enabler for remote diagnostics.
- Object-oriented and structured application design
- Direct link from HMI process displays to the corresponding software module in the controller software
- life cycle support
- large installed base
- ABB policy for long-term life cycle support and compatible software upgrades.

**Conclusion**

ABB's System 800xA Minerals Library is designed for greenfield plants as well as control system upgrades. Based on parameterised object-oriented software modules, it helps to reduce engineering complexity, minimise downtime caused by abnormal situations, and simplify fault-finding. Its ability to reduce operating costs and increase productivity over the life cycle of the production facility is widely attested. More than 300 sites in the cement and minerals industries are benefiting from the library every day. ▬

Figure 12: main cement process overview using ABB's System 800xA extended operator workplace

