

Analog Annunciator Unit

SACO 16 A3

Product Guide

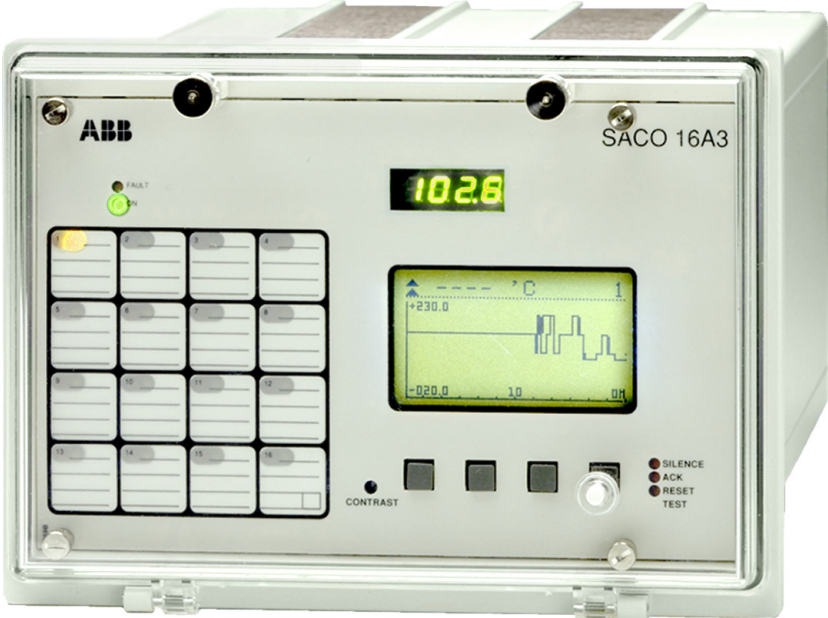

Features

- Powerful, flexible and field-customizable 16-channel analog input signal annunciator unit
- A full choice of 26 standardized field-selectable channel input signal types
- Four alarm/trip levels per channel; two low set and two high set points
- The last thirty events with time markings stored for local presentation
- Bar graph, curve or numerical display of set and measured parameter values
- Extensive data communication via the serial interface and the SPA bus
- Parameter selection and adjustment from front panel or via serial interface
- Sophisticated hardware and software self-supervision system for maximum operational reliability under the most demanding environmental conditions
- Powerful software support for parameterization of the relay, for reading measured and recorded values, events, etc., and for storing readings
- Member of the SPACOM product family and ABB's Distribution Automation system
- CE marking according to the EC directive for EMC

Application

The analog annunciator unit is used in a variety of applications requiring monitoring of analog quantities such as temperature, current, voltage, power, etc. in power plants, substations and industry. The equipment is also used in off-shore installations. For temperature measurement standard Pt or Ni sensors are used. For measuring electrical quantities measuring transducers with standard mA or V outputs are employed.

The annunciator units can be used as independent stand-alone units, or they can be integrated via a fibre-optic bus to form complete supervision, event sequence reporting and data acquisition systems.

Design

The channels of the analog annunciator unit measure voltage, current and resistance via sensors or transducers in the process. Further, contact signals can be wired to the input channels. The signal type can be separately set for each channel.

The channel inputs are galvanically separated from earth and from the digital part of the annunciator electronics, but the channels are galvanically interconnected. This arrangement facilitates the supervision and the indication of earth faults in the transducers or the transducer wiring.

The alarm channel inputs accept the following signal levels: 0...5 mA, 1...5 mA, 0...20 mA and 4...20 mA, 0...1 V, 0...5 V, 1...5 V, 0...10 V and 2...10 V. The following standard sensors types can be used for temperature measurement: Pt 100, Pt 250, Pt 1000, Ni 100, Ni 120, Ni 250, Ni 1000. Further, any Pt or Ni signal within the range 65...1000 Ω , potentiometric signal within the range 0...200 Ω , 0...500 Ω , 0...1 k Ω , 0...2 k Ω , 0...2.5 k Ω , 0...10 k Ω can be used and scaled. For the resistance sensors two- or three-wire connection can be used.

In addition, the input channels can be activated by a making or a breaking contact.

The values measured can be shown as numerical values, bar graphs or curves on the dot matrix display on the front panel. The same information can also be read by a superior system via the serial interface.

The content of the event sequence register can be read on the display. The total system can be configured by means of the push-buttons and the display on the front panel, or via the serial interface.

When a measured signal exceeds or falls below the set start value of the channel a visual indication is obtained on the alarm

panel. At the same time the acoustic alarm output contact picks up and, if configured, a group alarm relay operates. The event thus generated is stored in the event register.

Any information generated in the annunciator unit can be read by a hierarchically superior system via the serial interface.

Data communication

The relay is provided with a serial interface on the rear panel. By means of a bus connection module type SPA-ZC 17/S or SPA-ZC 21/S the relay can be connected to the fibre-optic SPA bus. The bus connection module type SPA-ZC 21/S is powered from the host relay, whereas the bus connection module SPA-ZC 17/S is provided with a built-in power unit, which can be fed from an external secured power source. The relay communicates with higher-level data acquisition and control systems over the SPA bus.

Self-supervision

The annunciator incorporates a sophisticated self-supervision system which increases the availability of the device and the reliability of the system. The self-supervision system continuously monitors the hardware and the software of the equipment. The system also supervises the operation of the auxiliary supply module and the electronics' voltages generated by the module.

Auxiliary supply voltage

The auxiliary supply of the relay is obtained from an internal plug-in type power supply module. Two auxiliary power module versions are available: type SPGU 240A1 for the supply voltage range 80...265 V ac/dc and type SPGU 48B2 for the supply voltage range 18...80 V dc. The power supply module forms the internal voltages required by the annunciator.

Technical data

Table 1: Annunciator channels

Number of channels per annunciator unit	16
Selectable transducer signal types	0...5 mA, 1...5 mA, 0...20 mA, 4...20 mA 0...1 V, 0...5 V, 1...5 V, 0...10 V, 2...10 V Pt 100, Pt 250, Pt 1000 Ni 100, Ni 120, Ni 250, Ni 1000 One selectable Pt or Ni signal within the range 65...1000 Ω, potentiometric signal within the range 0...200 Ω, 0...500 Ω, 0...1 kΩ, 0...2 kΩ, 0...2.5 kΩ, 0...10 kΩ, contact function
Scaling types	linear or non-linear
Signal filtering, selectable time basis for 0...90% step response	0.3 s, 1 s or 5 s
Set-point values per channel	two HI and two LO set-points or one HI and one LO plus one rise time and one fall time set-point
Channel starting delay at set-point value transition	0...255 s
Channel resetting delay at set-point value resetting	0...255 s
Deadband setting range, on a per channel basis	0...100 per mille
Measuring accuracy	0.5% of scale range
Transducer supply	24 V dc ±10%, max. 320 mA
Transducer supervision, measuring mode	Fully selectable upper and lower transducer signal limit values
Transducer circuit earth-fault supervision	Integrated with a sensitivity of 5...10 kΩ
Transducer oscillation supervision	Selectable 1...255 events/s. Can even be set out of function
Reference channel function	Any channel may be used as reference channel. The reference value may also be the average value of the measurement value of channels 2...16
Reference value deviation set-point values	Two selectable set-point values, one upper and one lower, separately given at 33% and 83% of the measuring range. Between these given set-point values the set-point values are interpolated and outside the given set-point values the set-point values are extrapolated from the given set-point values
Recording of change in value to be measured	Selectable setting value for size of change to be stored as an event in the event sequence register

Table 2: Realarm functions

Permanently groupable realarm output relays	Six relays with one NO contact per relay. The contacts may be given NC function by means of jumpers
Audible alarm output	One relay with one NO contact (NC contact by jumper)
Self-supervision system output	One relay with one NO contact (NC contact by jumper)
Relay contact rated current/max. breaking current	3 A/250 V ac or dc

Table 3: External control inputs

Audible alarm reset	NO contact circuit
Alarm acknowledge	NO contact circuit
Alarm channel reset	NO contact circuit
Remote testing	NO contact circuit
Control of unit into LOCAL mode	NO contact circuit
Control of unit into REMOTE mode	NO contact circuit
Clock synchronization	NO contact circuit, pulse length > 100 ms, 48 V dc, 4 mA

Table 4: Data communication

Transmission mode	Fibre-optic serial bus	
Coding	ASCII	
Data transfer, selectable	4800 or 9600 Bd	
Electrical/optical bus connection module, powered from the host unit	for plastic core cables	SPA-ZC 21BB/S
	for glass fibre cables	SPA-ZC 21MM/S
Electrical/optical bus connection module, powered from the host unit or from an external power source	for plastic core cables	SPA-ZC 17BB/S
	for glass fibre cables	SPA-ZC 17MM/S

Table 5: Auxiliary supply modules

Type of module	SPGU 240A1	rated voltages U_n	110/120/230/240 V ac 110/125/220 V dc
		operative range	80...265 V ac/dc
	SPGU 48B2	rated voltages U_n	24/48/60 V ac
		operative range	18...80 V dc
	Power consumption under quiescent/operation conditions		~20 W/~30 W

Table 6: Tests and standards

Test voltages	Between channel and control inputs and annunciator case, supply inputs and relay outputs	
	Dielectric test voltage (IEC 60255-5)	500 V, 50 Hz, 1 min
	Impulse test voltage (IEC 60255-5)	1 kV, 1.2/50 μ s, 0.5 J
	HF test voltage (IEC 60255-5)	1 kV, 1 MHz
Test voltages	Between supply inputs and case, relay outputs and case, supply inputs and relay outputs between themselves	
	Dielectric test voltage (IEC 60255-5)	2 kV, 50 Hz, 1 min
	Impulse test voltage (IEC 60255-5)	5 kV, 1.2/50 μ s, 0.5 J
	HF test voltage (IEC 60255-5)	2.5 kV, 1 MHz
Environmental conditions	Ambient service temperature range without matrix display	-10...+55°C
	Ambient service temperature range, including matrix display	-10...+45°C
	Long term damp heat withstand (IEC 60068-2-3)	<95%, +40°C, 56 d/a
	Ambient transport and storage temperature range	-20...+55°C
	Degree of protection by enclosure when panel-mounted	IP 54
	Weight of annunciator unit	~4.5 kg

Block diagram

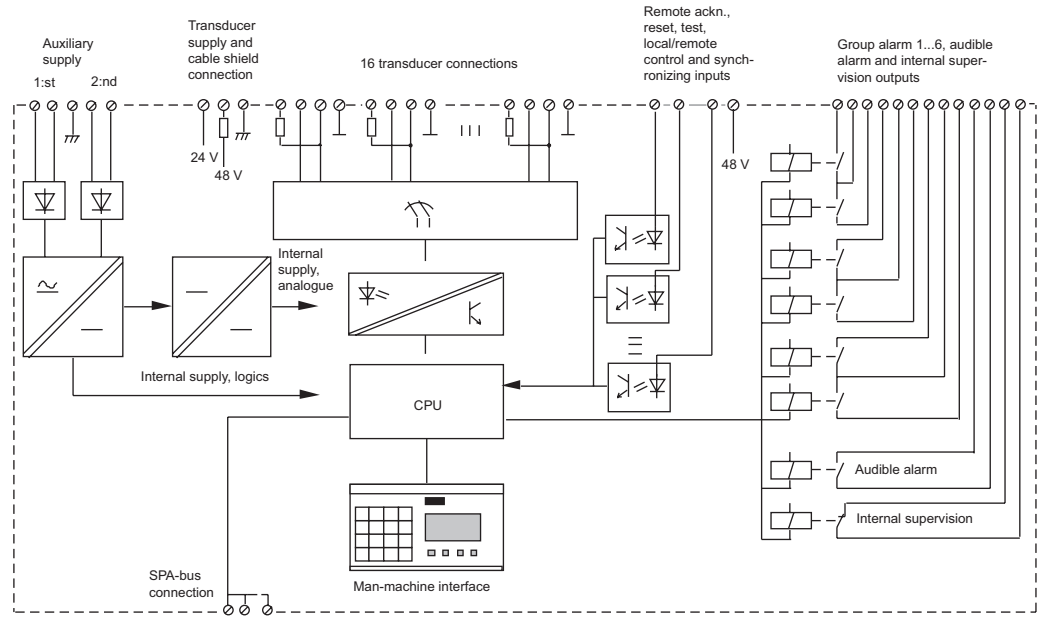

Fig. 1 Block diagram

Mounting and dimensions

Flush mounting

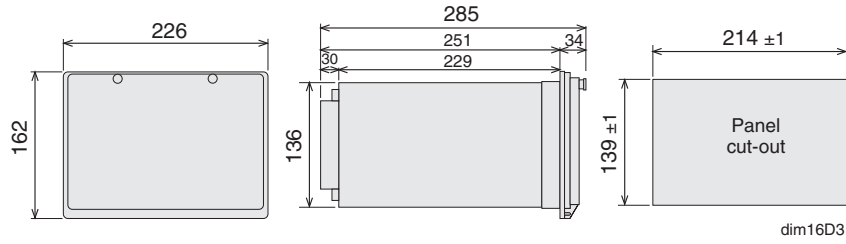

Fig. 7 Flush-mounting relay case (dimensions in mm)

Semi-flush mounting



Fig. 8 Semi-flush mounting relay case (dimensions in mm)

Mounting in 19 inch cabinets and frames

An ancillary mounting plate, height 4U (~177 mm), is recommended to be used when the annunciators are to be mounted in 19 inch frames or cabinets. The ancillary mounting

plate type SPA-ZX 104 accommodates three units, type SPA-ZX 105 two units and type SPA-ZX 106 one unit.

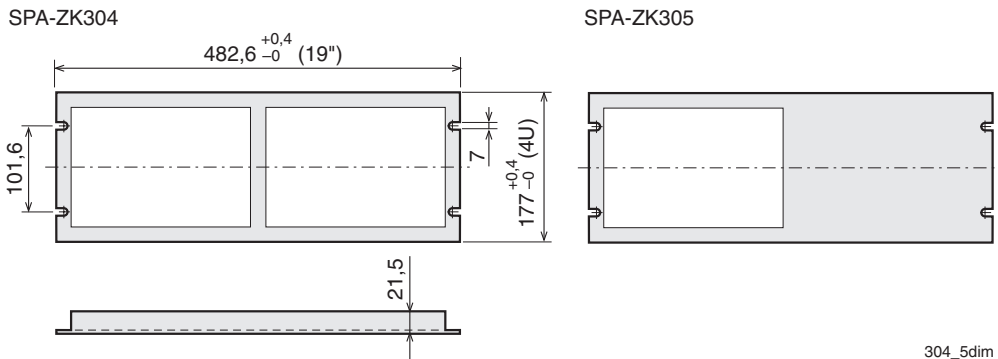

Fig. 9 Mounting cabinets and frames (dimensions in mm)

Ordering

Table 10: When ordering, please specify:

Ordering information	Ordering example
1. Type designation and quantity	SACO 16A3, 5 pieces
2. Order number	RS 812 016-AA
3. Auxiliary voltage	$U_{aux} = 110 \text{ V dc}$
4. Accessories	-
5. Special requirements	-

Table 11: Order numbers

Analog annunciator unit SACO 16A3	RS 812 016-AA, -BA
Analog annunciator unit SACO 16A3R without a dot matrix display on the front panel	RS 812 015-AA, -BA
The last two letters of the order number indicate the auxiliary voltage U_{aux} of the annunciator unit as follows:	AA equals $U_{aux} = 80... 265 \text{ V ac/dc}$
	BA equals $U_{aux} = 18...80 \text{ V dc}$

References

Table 12: Additional information

Analogue input annunciator, User's manual and Technical description SACO 16 A3	1MRS751015-MUM
--	----------------



ABB Oy
Distribution Automation
P.O. Box 699
FI-65101 Vaasa, FINLAND
Tel +358 10 22 11
Fax +358 10 224 1094
www.abb.com/substationautomation