

CATALOG | SEPTEMBER 2023

Low voltage

IE5 Synchronous reluctance motors



With expertise, and a comprehensive portfolio of products and life-cycle services, we help value-minded industrial customers improve their energy efficiency and productivity.

Low voltage IE5 Synchronous reluctance motors

Sizes 132 to 315, 5.5 to 315 kW

3	Low voltage IE5 Synchronous reluctance motors
4	Ultimate efficiency and reliability to optimize your cost of ownership
6	Product features
7	IE5 according to IEC TS 60034-30-2
8	High output for compactness
9	Technology
11	Synchronous reluctance motors with ABB variable speed drives
12	Mounting arrangements
13	Ordering information
14	Rating plates
15	Technical data
15	IE5 Synchronous reluctance motors 400 V
16	IE5 Synchronous reluctance motors 500 V
17	IE5 Synchronous reluctance motors 690 V
18	IE5 Synchronous reluctance motors 460 V
19	High output Synchronous reluctance motors 400 V
20	Variant codes
24	Mechanical design
24	Motor frame and drain holes
25	Heating elements
26	Bearings
28	Bearing life and lubrication
30	Radial forces
31	Axial forces
32	Terminal box
32	Standard terminal box
34	Terminal box dimensions
36	Terminal boxes and boards
37	Terminal box alternatives
38	Optional adapters
40	Dimension drawings
42	Motors in brief
43	ABB Access
44	Total product offering
45	ABB's portfolio of drives

Synchronous reluctance motors

Ultimate efficiency and reliability to optimize your cost of ownership



Traditional induction motor



IE5 SynRM motor

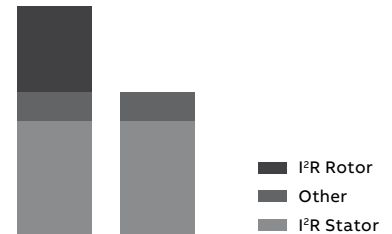

Losses

Innovation inside

The idea is simple. Take a conventional, proven stator technology and a innovative rotor design. Then combine them with a best-in-class ABB drive loaded with new, purpose-designed software.

Magnet-free design

Synchronous reluctance technology combines the performance of the permanent magnet motor with the simplicity and service-friendliness of an induction motor. The rotor has neither magnets nor windings and suffers virtually no power losses. And because there are no magnetic forces in the rotor, maintenance is as straightforward as with induction motors.

SynRM technology	Benefit
Higher efficiency IE5	Lowest energy consumption
No rare earth metals	Environmental sustainability
Magnet-free rotor	Easy service
Lower winding and bearing temperatures	Longer life time, extended service intervals
Better controllability	Accurate speed and torque control
Lower noise level	Better working environment
Same size with IE2	Drop-in replacement

Highest reliability to minimize the cost of not running

IE5 synchronous reluctance motors have very low winding temperatures, which increases the reliability and lifetime of the winding. More importantly, the cool synchronous reluctance rotor means significantly lower bearing temperatures – an important factor because bearing failures cause about 70 percent of unplanned motor outages.

Full motor control, down to zero speed

Many processes require accurate speed control. As the name says, SynRM is a synchronous motor that always runs at reference speed with practically no error, without an encoder. Even the best slip compensation systems in an induction motor inverter will never match the precision of SynRM. Sometimes your application may require you to run your motor at slow speeds, for example at less than 40 rpm. If you are using SynRM and your drive cannot provide the necessary torque, it may trip. This means you may have downtime while the problem is being debugged. ABB drives provide full control and torque down to zero speed, even without speed sensors.

For all applications

The SynRM motor can be used in any application where an induction motor is used, like pumps, fans, compressors, extruders, conveyors and wire drawing machines to name some.

Drop-in replacement

The IE5 SynRM motor is an ideal solution for motor retrofits. It is the same size as an IE2 induction motor, eliminating the need for mechanical modifications. The increased efficiency will, on the other hand, reduce the payback time of the investment.

Synchronous reluctance motors

Product features

Efficiency & MEPS

International minimum efficiency performance standards (MEPS) for measuring the efficiency of VSD-only types of motors - such as synchronous reluctance motors - are under development. No local MEPS efficiency requirements for VSD-only motors have been issued by September 2022.

Service

Servicing synchronous reluctance motors is as straightforward as with induction motors. The winding technology is identical to induction motors. The rotor does not include any magnetic materials, which means that the motor can be disassembled and serviced using the same procedure as for conventional induction motors. For test runs, SynRM capable frequency converter is needed.

Package selection

The technical data section lists matching motor and drive packages for easy package selection for pump and fan applications. Refer to ABB for package selection for other speeds or applications, or use the Drive-Size software.

Insulation protection

Synchronous reluctance motors have the same stator winding insulation as other ABB low voltage motors. The insulation is approved for 500 V VSD supply. For voltages above 500 V, follow ABB's instructions regarding the correct insulation system and the output filters of the drive.

Bearing currents

Synchronous reluctance motors rated above 100 kW are equipped with one insulated bearing as standard, which together with the correct cabling is sufficient to secure trouble-free operation up to 350 kW. Above 350 kW the drive should be equipped with a common-mode filter as an additional measure.

Cabling, grounding, and EMC

Synchronous reluctance motors are not equipped with EMC filters as standard. The variant code to order EMC cable glands is +704.

The use of a frequency converter sets higher demands on the cabling and grounding of the drive system. In other than exceptional circumstances, the motor must be cabled with shielded symmetrical cables and cable glands providing 360-degree bonding (EMC glands). For motors up to 30 kW, asymmetrical cables can be used, but shielded cables are always recommended, especially if there are sensitive components in the driven application.

For motors from frame size 280 upwards, additional potential equalization is needed between the motor frame and machinery, unless the motor and the driven machine are installed on a common steel base. When a steel base is used for potential equalization, the high frequency conductivity of the connection must be checked. For more information, see the ABB manual "Grounding and cabling of drive systems", 3AFY61201998 Rev C.

To meet EMC requirements, special EMC cables must be used in addition to the correct cable gland mounting, with additional special earthing pieces. For more information, refer to drive manuals.

Synchronous reluctance motors

IE5 according to IEC TS 60034-30-2

New technical specification IEC TS 60034-30-2 (2016) specify the efficiency classes for variable speed drive (VSD) motors (i.e. motors which cannot be operated direct on line (DOL)). Typical standard low voltage induction motor efficiency is determined according to IEC 60034-30-1 in sinusoidal (DOL) supply.

In practice, IE5 motor has 20% less losses compared to an IE4 motor. In the technical tables you can see the measured SynRM motor efficiency with VSD supply. Typical values of IE3 induction motor efficiency with VSD supply are listed for comparison.

IEC TS 60034-30-2 highlights

- The IE class limit values in new IEC TS 60034-30-2 are reduced by adding the additional harmonic losses caused by the drive:
 - 15% additional losses for motors up to 90kW
 - 25% additional losses for motors above 90kW
- Limit values available also for IE5 level
- Limit values to be achieved with 90% speed, 100% torque

DOL or VSD motor – Same IE class, same efficiency performance in VSD duty

This allows direct comparison in IE class level of traditional induction motors in variable speed usage and advanced technology motors designed only for variable speed drive (like Synchronous reluctance motors). It does not matter if the IE classification is done with DOL supply according to IEC 60034-30-1 or with VSD supply according to IEC TS 60034-30-2. The given IE class still illustrates efficiency performance of both solutions in VSD operation very well. Same IE class, same efficiency performance.

Example:

110 kW 4-pole motor efficiency	
IEC 60034-30-1 (DOL)	IEC TS 60034-30-2 (VSD)
Losses 4,2 kW	Losses 4,2 kW x 1,25 = 5,25 kW
Eff. (110kW/114,2 kW) = 96,3%	Eff. (110 kW/ (110 + 5,25 kW)) = 95,4%
IE4 limit 96,3%	IE4 limit 95,4% %
Same motor is IE4 according to both standards	

IE5 SynRM efficiency with VSD duty for same rating is 96,8 %.

Synchronous reluctance motors

High output for compactness

High performance for compact machine designs

High output SynRM motor is a compact and yet highly efficient motor that's up to three frame sizes smaller than a conventional motor. Rotor losses are virtually eliminated, resulting in cool running. This advantage is the basis for a high output SynRM design that delivers high power density coupled with good efficiency. High output SynRM motors enable compact and cost efficient machine designs or increased machine output without increasing motor size.

Same power - smaller motor

The High output synchronous reluctance motor is up to three frame sizes smaller than an induction motor with the same output. The size advantage increases with speed so the benefit is greater for 3000 than for 1500 rpm applications. A light, compact motor means cost-efficient installations.

Same size - higher power

The size advantage of synchronous reluctance motors can also be exploited to increase capacity without changes in the motor installation. In other words, a high output synchronous reluctance motor can deliver up to twice the output of an induction motor of the same size. Again, this power advantage is greater at higher speeds.

Customer benefits

Same output from a smaller size or higher output from the same size.

Application example, 22 kW, 1500 rpm		
	High output SynRM motor	IE3 induction motor
Frame size	160	180
Weight, kg	174	222

Reduced system space – lower weight, easier installation.

Application example, 37 kW, 3000 rpm		
	High output SynRM motor	IE3 induction motor
Frame size	160	200
Weight, kg	157	298



Synchronous reluctance motors

Technology

01 Cross-sectional illustration of a four-pole synchronous reluctance motor (left), and the definition of the magnetic d- and q-axes of its rotor (right)

Introduction

The synchronous reluctance motor is a three-phase electric motor with a magnetically anisotropic rotor structure. In the four-pole version, the rotor has four high- and four low-permeance axes. High permeance means high magnetic conductivity and higher inductance, while low permeance means lower inductance.

Reluctance is the inverse of permeance and is, in practical terms, magnetic resistance; high reluctance results in low inductance. The axes with high permeance can be referred to as the direct or d-axis, while the axes with high reluctance can be referred to as the quadrature or q-axis.

The figures below show cross-sectionals of a synchronous reluctance motor. The different axes in the rotor are identified in the figure on the right.

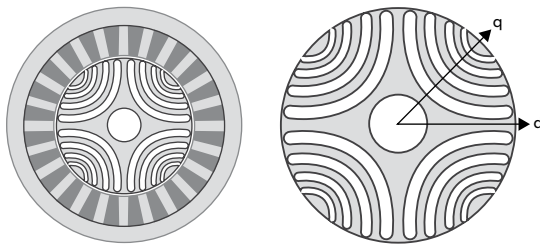

01

Functional principle

When a magnetic field is produced in the air gap by applying exciting currents to the stator windings, the rotor will strive to align its most magnetically conductive axis, the d-axis, with the applied field, in order to minimize the reluctance in the magnetic circuit. In other words, torque is produced in the air gap between the stator and rotor whenever the applied field vector and the d-axis of the rotor are not aligned.

The magnitude of the vector field and the speed of its rotation can be controlled by a frequency converter. The high saliency of the rotor means that its angular position can easily be detected by a sensorless control. Expensive absolute encoders, resolvers, and other rotational sensors are therefore not required.

The sensorless control system keeps track of the rotor's angular position in relation to the stator and creates a vector field with accurate magnitude and rotational speed in accordance with the control reference signals dictated by the load.

Since performance is dependent on the information about the rotor's position, the motor needs a frequency converter; it cannot be started with a direct-on-line supply. The rotor runs in synchronism with the applied vector field, striving to minimize reluctance in the magnetic circuit that is present. This functional principle has given its name to the technology – synchronous reluctance.

Synchronous reluctance motors run smoothly due to the sinusoidal air gap field distribution and operation with sinusoidal current.

Rotor design

The rotor design of a synchronous reluctance motor comprises electric steel plates stacked together to form a rotor package. The electric steel plates have punched holes as flux barriers, as illustrated in the figure 01.

The torque produced by the motor is proportional to the difference between the inductances on the d- and q-axes: the greater this difference, the greater the torque production. The synchronous reluctance motor is therefore designed with magnetically conductive material, iron, in the d-axis and magnetically insulating material, air, in the q-axis.

As the rotor has no windings and consequently no joule losses, it runs considerably cooler and with better efficiency than the rotor in an induction motor. The cool running of the rotor also means lower bearing temperatures, which in turn increase the reliability of the bearing system.

Further considerations

Eliminating rotor joule losses in the synchronous reluctance motor has led to compact construction, good efficiency levels and cooler bearing temperatures. The main disadvantage of this technology is that the motor's power factor is generally not as good as with induction motors.

Since there is always a frequency converter between the motor and the grid, the lower power factor is not apparent on the grid side and consequently does not have an impact on the grid supply dimensioning. However, the lower power factor may sometimes mean that a frequency converter with a higher current rating is needed.

The stator and frame design are based on proven induction motor technology, and the rotor consists of only iron and air. The lack of windings and permanent magnets in the rotor eliminates potential faults associated with these components, resulting in robust motor technology optimized for industrial variable speed applications.

Synchronous reluctance motors with ABB variable speed drives



ACS580 general purpose drive highlights

- A scalable offering from 0.75 kW to 500 kW.
- All compatible drive for typical light industry applications such as compressors, conveyors, mixers, pumps and fans, as well as many other linear, variable and constant torque applications.
- The assistant control panel with multiple language choices as standard.
- An optional Bluetooth control panel for wireless commissioning and monitoring. Primary settings and application control macros ensure quick product setup.
- Enclosure IP55 for harsh conditions.
- Supports various motor types: induction, permanent magnet, and synchronous reluctance motors.
- Integrated safety, including the safe-torque off (STO) feature as standard.
- Supports various motor types: induction, permanent magnet, and synchronous reluctance motors.

Industry specific ACH580 drives for HVAC and ACQ580 drives for water and wastewater are also available for SynRM control. Consult ABB to find the drive that matches your business needs the best or visit our web page <https://new.abb.com/drives>.

ACS880 industrial drive highlights

- All compatible drives range for numerous demanding industries and applications such as cranes, extruders, winches, winders, conveyors and compressors, among others.
- Compact design for easy installation, commissioning, and maintenance.
- Enclosure classes IP21, IP22, IP42, IP54 and IP55 for various ambient conditions.
- Integrated safety, including the safe-torque-off (STO) feature as standard.
- A memory module stores drive settings and can be installed in a new drive by anyone on the site.
- Supports various motor types: induction, permanent magnet, and synchronous reluctance motors.
- Direct torque control (DTC) – ABB's signature motor control technology provides precise speed and torque control also without any feedback devices like encoders or position sensors.

Consult ABB to find the drive that matches your business needs the best or visit our web page <https://new.abb.com/drives>.

Mounting arrangements

Foot-mounted motor

Code I / code II

Product code pos. 12

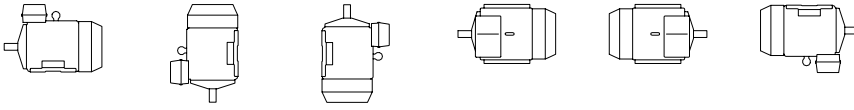

A: foot-mounted, term. box top

IM B3	IM V5	IM V6	IM B6	IM B7	IM B8
IM 1001	IM 1011	IM 1031	IM 1051	IM 1061	IM 1071

Flange-mounted motor, large flange

Code I / code II

Product code pos. 12

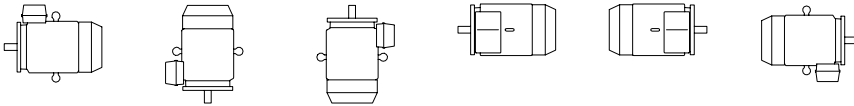

B: flange mounted, large flange

IM B5	IM V1	IM V3	*)	*)	*)
IM 3001	IM 3011	IM 3031	IM 3051	IM 3061	IM 3071

Flange-mounted motor, small flange

Code I / code II

Product code pos. 12

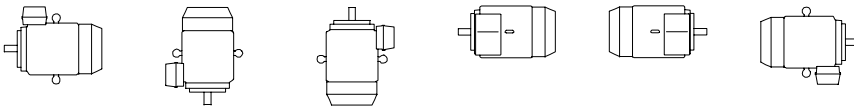

C: flange mounted, small flange

IM B14	IM V18	IM V19	*)	*)	*)
IM 3601	IM 3611	IM 3631	IM 3651	IM 3661	IM 3671

Foot- and flange-mounted motor with feet, large flange

Code I / code II

Product code pos. 12

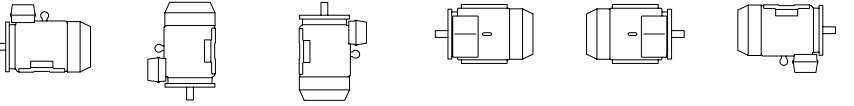

H: foot/flange-mounted, term. box top

IM B35	IM V15	IM V35	*)	*)	*)
IM 2001	IM 2011	IM 2031	IM 2051	IM 2061	IM 2071

Foot- and flange-mounted motor with feet, small flange

Code I / code II

Product code pos. 12

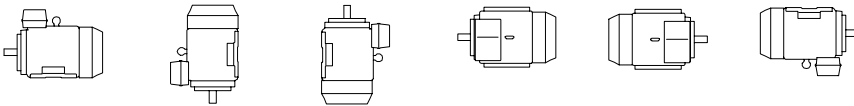

J: foot/flange-mounted, small flange

IM B34	IM V17	IM 2131	IM 2151	IM 2161	IM 2171
IM 2101	IM 2111	IM 2131	IM 2151	IM 2161	IM 2171

Foot-mounted motor, shaft with free extensions

Code I / code II

Product code pos. 12

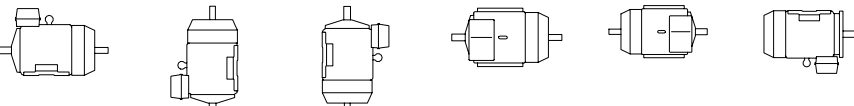

IM 1002	IM 1012	IM 1032	IM 1052	IM 1062	IM 1072
---------	---------	---------	---------	---------	---------

*) Not stated in IEC 60034-7.

Note: If the motor is mounted shaft upwards, take measures to prevent water or any other liquid from running down the shaft into the motor.

Ordering information

Explanation of the product code

Motor type	Motor size	Product code	Mounting arrangement code, Voltage and frequency code, Generation code	Variant codes
M3BL	160	MLA 3GBL 162 413	- ASC	445
		1 2 3 4 5 6 7 8 9 10 11 12 13 14		

Positions 1 to 4

3GAL	Totally enclosed fan-cooled synchronous reluctance motor with cast aluminum frame, size 132
3GBL	Totally enclosed fan-cooled synchronous reluctance motor with cast iron frame, sizes 160 - 315

Positions 5 to 6

IEC size	
13:	132
16:	160
18:	180
20:	200
22:	225
25:	250
28:	280
31:	315

Position 7

Pole pairs	
2:	4 poles

Positions 8 to 10

Running number	

Position 11

	-(dash)
--	---------

Position 12 (marked with black dot in data tables)

Mounting arrangement	
A:	Foot-mounted
B:	Flange-mounted, large flange
Use a variant code for ordering any other mounting arrangement	

Position 13 (marked with black dot in data tables)

Voltage and frequency	
D:	400 VΔ 50 Hz or 460 VΔ 60 Hz
E:	500 VΔ 50 Hz
F:	500 VY 50 Hz
S:	400 VY 50 Hz or 460 VY 60 Hz
U:	690 VY 50 Hz

Position 14

Generation code	
B	High output synchronous reluctance motors
C	IE5 synchronous reluctance motors

Variant codes

The product code must be, if needed, followed by variant codes.

Rating plates

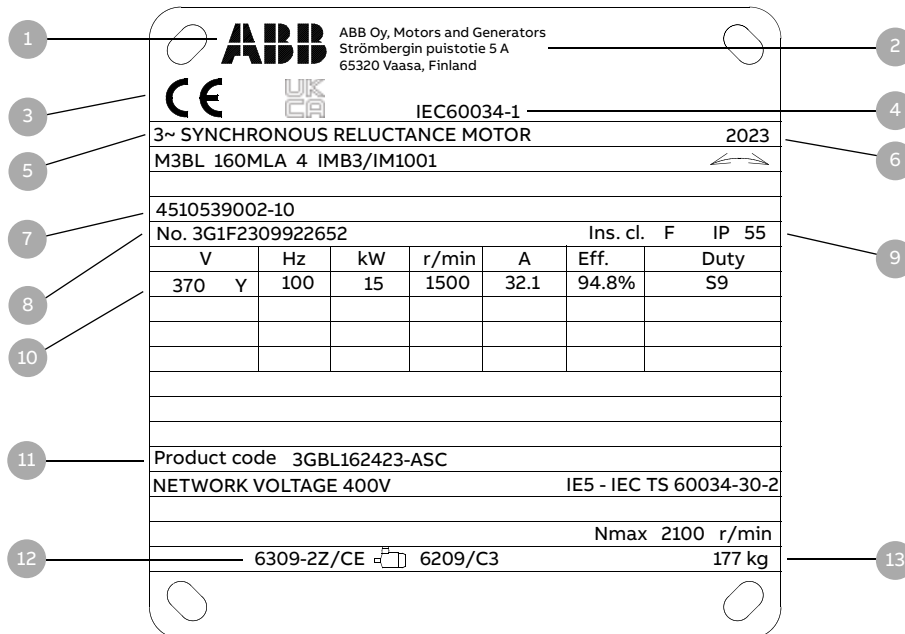

- 1 ABB logo
- 2 Manufacturing place
- 3 CE mark on Ecodesign approved motors UKCA mark on UK approved motors
- 4 Manufacturing standard
- 5 Product description
- 6 Manufacturing year
- 7 Factory order reference number
- 8 Serial number
- 9 Insulation class, IP protection class
- 10 Voltage, Frequency, output, speed, current, power factory, duty
- 11 Product code
- 12 Bearing type
- 13 Weight

Technical data

IE5 Synchronous reluctance motors 400 V

IE5 synchronous reluctance motors, network voltage 400 V

Output, kW	Type designation	Product code	Speed at 100% of nominal power (M) (r/min)	IE class acc. to IEC TS60034-30-2	Motor efficiency with VSD supply $T_N = 100\%$, $n_N = 100\%$	Typical IE3 induction motor efficiency with VSD supply* $T_N = 100\%$, $n_N = 100\%$	Max speed, n_{max} r/m	Current, I_N A	Torque		Rotor inertia ($J = 1/4GD^2$) (M) (kgm ²)	Weight, Kg	Temperature rise class (M)
									T_e /Nm	T_{oi}/T_N Nm			
3000 r/min (100 Hz)			400 V network										
5.5	M3AL 132SMA 4	3GAL132217-●SC	3000	IE5	92.8	87.8	4500	12.1	17.5	1.5	0.0145	41	B
7.5	M3AL 132SMB 4	3GAL132227-●SC	3000	IE5	93.1	88.8	4500	16.5	23.9	1.5	0.0145	41	B
11	M3AL 132SMC 4	3GAL132237-●SC	3000	IE5	94.0	90.0	4500	24.5	35.0	1.5	0.0184	47	B
15	M3AL 132SMD 4	3GAL132247-●SC	3000	IE5	94.1	90.8	4500	32.9	47.8	1.5	0.0184	47	B
11	M3BL 160MLA 4	3GBL162417-●SC	3000	IE5	93.6	90.0	4500	25.6	35.0	1.5	0.0579	133	B
15	M3BL 160MLB 4	3GBL162427-●SC	3000	IE5	95.1	90.8	4500	34.6	48.0	1.5	0.0579	133	B
18.5	M3BL 160MLC 4	3GBL162437-●SC	3000	IE5	94.6	91.4	4500	43.3	59.0	1.5	0.0579	133	B
22	M3BL 180MLB 4	3GBL182427-●SC	3000	IE5	95.5	91.7	4500	50.5	70.0	1.6	0.116	190	B
30	M3BL 200MLC 4	3GBL202437-●SC	3000	IE5	95.9	92.4	4500	68.9	95.6	1.9	0.207	277	B
37	M3BL 200MLD 4	3GBL202447-●SC	3000	IE5	96.1	92.8	4500	84.5	118	2.0	0.207	277	B
45	M3BL 225SMB 4	3GBL222227-●SC	3000	IE5	96.1	93.2	4500	99.8	143	2.1	0.302	330	B
55	M3BL 250SMA 4	3GBL252217-●SC	3000	IE5	96.4	93.5	3600	123	175	1.6	0.499	396	B
75	M3BL 250SMB 4	3GBL252227-●SC	3000	IE5	96.5	94.0	3600	167	239	2.0	0.499	396	B
90	M3BL 250SMC 4	3GBL252237-●SC	3000	IE5	96.4	94.3	3600	198	286	2.3	0.632	454	B
1500 r/min (50 Hz)			400 V network										
5.5	M3AL 132SMA 4	3GAL132213-●SC	1500	IE5	93.7	88.2	4500	11.7	35.0	1.5	0.0277	63	B
7.5	M3AL 132SMB 4	3GAL132223-●SC	1500	IE5	93.7	89.1	4500	15.7	47.8	1.5	0.0277	63	B
11	M3AL 132SMC 4	3GAL132233-●SC	1500	IE5	94.2	90.2	4500	23.8	70.0	1.5	0.0317	69	B
11	M3BL 160MLA 4	3GBL162413-●SC	1500	IE5	94.0	90.2	4500	24.2	70.0	1.5	0.0702	160	B
15	M3BL 160MLB 4	3GBL162423-●SC	1500	IE5	94.9	91.0	4500	31.3	95.0	1.5	0.0864	177	B
18.5	M3BL 180MLB 4	3GBL182423-●SC	1500	IE5	95.0	91.6	4500	42.8	118	2.6	0.156	222	B
22	M3BL 180MLC 4	3GBL182433-●SC	1500	IE5	95.4	92.0	4500	49.4	140	2.2	0.156	222	B
30	M3BL 200MLB 4	3GBL202423-●SC	1500	IE5	95.9	92.7	4500	65.0	191	2.3	0.287	304	B
37	M3BL 225SMB 4	3GBL222223-●SC	1500	IE5	96.3	93.0	3600	79.3	236	2.2	0.38	385	B
45	M3BL 225SMC 4	3GBL222233-●SC	1500	IE5	96.3	93.4	3600	98.5	286	2.3	0.38	350	B
55	M3BL 250SMB 4	3GBL252223-●SC	1500	IE5	96.5	93.8	3600	117	350	2.3	0.632	454	B
75	M3BL 280SMA 4	3GBL282213-●DC	1500	IE5	96.2	94.3	2600	166	478	2.0	1	639	B
90	M3BL 280SMB 4	3GBL282223-●DC	1500	IE5	96.5	94.5	2600	199	573	2.1	1	639	B
110	M3BL 280SMC 4	3GBL282233-●DC	1500	IE5	96.7	94.3	2600	241	699	2.1	1.21	697	B
110	M3BL 315SMA 4	3GBL312213-●DC	1500	IE5	96.8	94.3	2200	243	702	2.0	1.64	873	B
132	M3BL 315SMB 4	3GBL312223-●DC	1500	IE5	96.8	94.6	2200	290	842	2.0	1.87	925	B
160	M3BL 315SMC 4	3GBL312233-●DC	1500	IE5	97.1	94.8	2200	343	1018	1.9	2.04	965	B
200	M3BL 315MLA 4	3GBL312413-●DC	1500	IE5	97.2	95.0	2200	428	1272	1.9	2.45	1116	B
250	M3BL 315LKA 4	3GBL312813-●DC	1500	IE5	97.1	95.0	2200	552	1591	2.0	3.04	1357	B
315	M3BL 315LKC 4	3GBL312833-●DC	1500	IE5	97.2	95.0	2200	662	2006	1.8	3.77	1533	F
1000 r/min (33.3 Hz)			400 V network										
7.5	M3BL 160MLA 4	3GBL162412-●SC	1000	IE5	93.1	87.7	4500	16.5	72.0	1.5	0.0702	160	B
11	M3BL 160MLB 4	3GBL162422-●SC	1000	IE5	93.7	89.0	4500	24.1	105	1.5	0.0864	177	B
15	M3BL 180MLC 4	3GBL182432-●SC	1000	IE5	94.2	90.0	4500	34.1	143	2.2	0.156	216	B
18.5	M3BL 200MLA 4	3GBL202412-●SC	1000	IE5	95.2	90.6	4500	39.9	177	1.5	0.287	304	B
22	M3BL 200MLB 4	3GBL202422-●SC	1000	IE5	95.0	91.1	4500	47.0	210	1.5	0.287	304	B
30	M3BL 225SMB 4	3GBL222222-●SC	1000	IE5	95.5	91.9	3600	64.7	287	2.1	0.38	348	B
37	M3BL 250SMA 4	3GBL252212-●SC	1000	IE5	95.6	92.4	3600	80.5	353	1.5	0.575	428	B
45	M3BL 280SMA 4	3GBL282212-●DC	1000	IE5	96.2	92.8	2600	98.6	430	2.3	1	639	B
55	M3BL 280SMB 4	3GBL282222-●DC	1000	IE5	96.0	93.3	2600	119	526	2.0	1	639	B
75	M3BL 280SMC 4	3GBL282232-●DC	1000	IE5	96.2	93.8	2600	160	715	2.1	1.21	697	B
75	M3BL 315SMA 4	3GBL312212-●DC	1000	IE5	96.5	93.8	2200	164	717	2.0	1.64	873	B
90	M3BL 315SMB 4	3GBL312222-●DC	1000	IE5	96.8	94.2	2200	199	859	2.0	1.87	925	B
110	M3BL 315SMC 4	3GBL312232-●DC	1000	IE5	96.8	93.9	2200	241	1051	1.9	2.04	965	B
132	M3BL 315MLA 4	3GBL312412-●DC	1000	IE5	97.1	94.3	2200	278	1261	1.7	2.45	1116	B
160	M3BL 315LKA 4	3GBL312812-●DC	1000	IE5	97.1	94.6	2000	341	1527	1.9	3.04	1357	B
200	M3BL 315LKC 4	3GBL312832-●DC	1000	IE5	97.3	94.8	2000	416	1910	1.8	3.77	1533	B

* Additional motor losses acc. to IEC TS 60034-30-2.

Technical data

IE5 Synchronous reluctance motors 690 V

IE5 synchronous reluctance motors, network voltage 690 V

Output, kW	Type designation	Product code	Speed at 100% of nominal power (M) (r/min)	IE class acc. to IEC TS60034-30-2	Motor efficiency with VSD supply $T_n = 100\%$, $nN = 100\%$	Typical IE3 induction motor efficiency with VSD supply* $T_n = 100\%$, $nN = 100\%$	Max speed, n_{max} r/m	Current, I_N A	Torque		Rotor inertia ($J = 1/4GD^2$) (M) (kgm ²)	Weight, Kg	Temperature rise class (M)
									T_n/T_N Nm	T_{ol}/T_N Nm			
3000 r/min (100 Hz)			690 V network										
5.5	M3AL 132SMA 4	3GAL132217-●UC	3000	IE5	92.5	87.8	4500	7.0	17.5	1.5	0.0145	41	B
7.5	M3AL 132SMB 4	3GAL132227-●UC	3000	IE5	92.8	88.8	4500	9.5	23.9	1.5	0.0145	41	B
11	M3AL 132SMC 4	3GAL132237-●UC	3000	IE5	92.9	90.0	4500	14.1	35.0	1.5	0.0184	47	B
15	M3AL 132SMD 4	3GAL132247-●UC	3000	IE5	93.7	90.8	4500	18.9	47.8	1.5	0.0184	47	B
11	M3BL 160MLA 4	3GBL162417-●UC	3000	IE5	93.6	90.0	4500	14.8	35.0	1.5	0.0579	133	B
15	M3BL 160MLB 4	3GBL162427-●UC	3000	IE5	94.9	90.8	4500	20.0	47.8	1.5	0.0579	133	B
18.5	M3BL 160MLC 4	3GBL162437-●UC	3000	IE5	94.5	91.4	4500	25.1	58.9	1.5	0.0579	133	B
22	M3BL 180MLB 4	3GBL182427-●UC	3000	IE5	95.4	91.7	4500	28.9	70.0	1.6	0.116	190	B
30	M3BL 200MLC 4	3GBL202437-●UC	3000	IE5	95.9	92.4	4500	39.3	95.5	1.9	0.207	277	B
37	M3BL 200MLD 4	3GBL202447-●UC	3000	IE5	96.1	92.8	4500	47.8	118	1.9	0.207	277	B
45	M3BL 225SMB 4	3GBL222227-●UC	3000	IE5	96.1	93.2	4500	57.2	143	2.3	0.302	330	B
55	M3BL 250SMA 4	3GBL252217-●UC	3000	IE5	94.4	93.5	4500	70.0	175	1.6	0.499	396	B
75	M3BL 250SMB 4	3GBL252227-●UC	3000	IE5	96.5	94.0	3600	96.0	239	2.1	0.499	396	B
90	M3BL 250SMC 4	3GBL252237-●UC	3000	IE5	96.4	94.3	3600	111	286	2.2	0.632	454	B
1500 r/min (50 Hz)			690 V network										
5.5	M3AL 132SMA 4	3GAL132213-●UC	1500	IE5	93.3	88.2	4500	6.8	35.0	1.5	0.0277	63	B
7.5	M3AL 132SMB 4	3GAL132223-●UC	1500	IE5	93.3	89.1	4500	9.2	47.8	1.5	0.0277	63	B
11	M3AL 132SMC 4	3GAL132233-●UC	1500	IE4	93.7	90.2	4500	13.9	70.0	1.5	0.0317	69	B
11	M3BL 160MLA 4	3GBL162413-●UC	1500	IE4	93.6	90.2	4500	14.1	70.0	1.5	0.0702	160	B
15	M3BL 160MLB 4	3GBL162423-●UC	1500	IE4	94.6	91.0	4500	18.4	95.5	1.5	0.0864	177	B
18.5	M3BL 180MLB 4	3GBL182423-●UC	1500	IE5	95.0	91.6	4500	24.3	118	2.6	0.156	222	B
22	M3BL 180MLC 4	3GBL182433-●UC	1500	IE5	95.4	92.0	4500	28.0	140	2.2	0.156	222	B
30	M3BL 200MLB 4	3GBL202423-●UC	1500	IE5	95.5	92.7	4500	37.3	191	2.3	0.287	304	B
37	M3BL 225SMB 4	3GBL222223-●UC	1500	IE5	96.3	93.0	3600	45.2	236	2.2	0.38	385	B
45	M3BL 225SMC 4	3GBL222233-●UC	1500	IE5	96.3	93.4	3600	54.8	286	2.3	0.38	350	B
55	M3BL 250SMB 4	3GBL252223-●UC	1500	IE5	96.5	93.8	3600	67.0	350	2.4	0.632	454	B
75	M3BL 280SMA 4	3GBL282213-●UC	1500	IE5	96.2	94.3	2600	92.6	477	2.0	1	639	B
90	M3BL 280SMB 4	3GBL282223-●UC	1500	IE5	96.3	94.5	2600	110	573	2.1	1	639	B
110	M3BL 280SMC 4	3GBL282233-●UC	1500	IE5	96.6	94.3	2600	133	700	2.1	1.21	697	B
110	M3BL 315SMA 4	3GBL312213-●UC	1500	IE5	96.7	94.3	2200	138	700	2.0	1.64	873	B
132	M3BL 315SMB 4	3GBL312223-●UC	1500	IE5	96.7	94.6	2200	165	840	2.0	1.87	925	B
160	M3BL 315SMC 4	3GBL312233-●UC	1500	IE5	97.0	94.8	2200	195	1019	1.9	2.04	965	B
200	M3BL 315MLA 4	3GBL312413-●UC	1500	IE5	97.1	95.0	2200	244	1273	1.9	2.45	1116	B
250	M3BL 315LKA 4	3GBL312813-●UC	1500	IE5	97.0	95.0	2200	314	1592	2.0	3.04	1357	B
315	M3BL 315LKC 4	3GBL312833-●UC	1500	IE5	97.1	95.0	2200	377	2005	1.8	3.77	1533	F
1000 r/min (50 Hz)			690 V network										
7.5	M3BL 160MLA 4	3GBL162412-●UC	1000	IE5	93.0	87.7	4500	9.5	71.6	1.5	0.0702	160	B
11	M3BL 160MLB 4	3GBL162422-●UC	1000	IE4	93.4	89.0	4500	13.8	105	1.5	0.0864	177	B
15	M3BL 180MLC 4	3GBL182432-●UC	1000	IE5	94.2	90.0	4500	19.3	143	2.3	0.156	216	B
18.5	M3BL 200MLA 4	3GBL202412-●UC	1000	IE5	95.0	90.6	4500	22.6	177	1.5	0.287	304	B
22	M3BL 200MLB 4	3GBL202422-●UC	1000	IE5	94.9	91.1	4500	26.5	210	1.5	0.287	304	B
30	M3BL 225SMB 4	3GBL222222-●UC	1000	IE5	95.5	91.9	3600	36.7	287	2.1	0.38	348	B
37	M3BL 250SMA 4	3GBL252212-●UC	1000	IE5	95.6	92.4	3600	46.0	353	1.5	0.575	428	B
45	M3BL 280SMA 4	3GBL282212-●UC	1000	IE5	96.0	92.8	2600	54.6	430	2.3	1	639	B
55	M3BL 280SMB 4	3GBL282222-●UC	1000	IE5	95.8	93.3	2600	66.8	525	2.0	1	639	B
75	M3BL 280SMC 4	3GBL282232-●UC	1000	IE5	96.0	93.8	2600	89.8	716	2.1	1.21	697	B
75	M3BL 315SMA 4	3GBL312212-●UC	1000	IE5	96.4	93.8	2200	91.6	716	2.0	1.64	873	B
90	M3BL 315SMB 4	3GBL312222-●UC	1000	IE5	96.6	94.2	2200	111	860	2.0	1.87	925	B
110	M3BL 315SMC 4	3GBL312232-●UC	1000	IE5	96.7	93.9	2200	134	1051	1.9	2.04	965	B
132	M3BL 315MLA 4	3GBL312412-●UC	1000	IE5	96.9	94.3	2200	156	1261	1.7	2.45	1116	B
160	M3BL 315LKA 4	3GBL312812-●UC	1000	IE5	96.9	94.6	2000	189	1528	1.0	3.04	1357	B
200	M3BL 315LKC 4	3GBL312832-●UC	1000	IE5	97.0	94.8	2000	232	1910	1.8	3.77	1533	B

* Additional motor losses acc. to IEC TS 60034-30-2.

Technical data

IE5 Synchronous reluctance motors 460 V

IE5 synchronous reluctance motors, network voltage 460 V

Output, kW	Type designation	Product code	Speed at 100% of nominal power (M) (r/min)	IE class acc. to IEC TS60034-30-2	Motor efficiency with VSD supply TN = 100%, nN = 100%	Typical IE3 induction motor efficiency with VSD supply* TN=100%, nN=100%	Max speed, nmax r/m	Current, IN A	Torque		Rotor inertia (J = 1/4GD2) (M) (kgm2)	Weight, Kg	Temperature rise class (M)
									T _e /Nm	T _{co} /T _N Nm			
3600 r/min (120 Hz)			460 V network										
5.5	M3AL 132SMA 4	3GAL132217-●SC	3600	IE5	92.0	87.9	4500	10.8	14.6	2.1	0.0145	41	B
7.5	M3AL 132SMB 4	3GAL132227-●SC	3600	IE5	92.5	88.7	4500	13.9	19.9	2.0	0.0145	41	B
11	M3AL 132SMC 4	3GAL132237-●SC	3600	IE5	93.5	89.7	4500	21.8	29.2	2.5	0.0184	47	B
15	M3AL 132SMD 4	3GAL132247-●SC	3600	IE5	94.1	89.7	4500	27.8	39.8	2.1	0.0184	47	B
11	M3BL 160MLA 4	3GBL162417-●SC	3600	IE5	93.0	89.7	4500	22.4	29.1	1.8	0.0579	133	B
15	M3BL 160MLB 4	3GBL162427-●SC	3600	IE5	94.2	89.7	4500	35.0	39.7	1.6	0.0579	133	B
18.5	M3BL 160MLC 4	3GBL162437-●SC	3600	IE5	94.3	90.5	4500	37.0	49.3	1.7	0.0579	133	B
22	M3BL 180MLB 4	3GBL182427-●SC	3600	IE5	95.3	90.5	6000	44.0	58.4	1.5	0.116	190	B
30	M3BL 200MLC 4	3GBL202437-●SC	3600	IE5	95.4	91.3	4500	61.0	79.7	1.5	0.207	277	B
37	M3BL 200MLD 4	3GBL202447-●SC	3600	IE5	95.7	92.0	4500	74.8	98.3	1.5	0.207	277	B
45	M3BL 225SMB 4	3GBL222227-●SC	3600	IE5	95.9	92.6	4200	88.3	119	1.5	0.302	330	B
55	M3BL 250SMA 4	3GBL252217-●SC	3600	IE5	96.0	92.6	3600	107	146	1.5	0.499	396	B
75	M3BL 250SMB 4	3GBL252227-●SC	3600	IE5	96.2	93.2	3600	149	198	1.5	0.499	396	B
1800 r/min (60 Hz)			460 V network										
5.5	M3AL 132SMA 4	3GAL132213-●SC	1800	IE5	93.8	90.5	4500	10.5	29.2	2.1	0.0277	63	B
7.5	M3AL 132SMB 4	3GAL132223-●SC	1800	IE5	94.1	90.5	4500	13.9	47.8	2.0	0.0277	63	B
11	M3BL 160MLA 4	3GBL162413-●SC	1800	IE5	94.4	91.3	4500	21.1	58.4	1.8	0.0702	160	B
15	M3BL 160MLB 4	3GBL162423-●SC	1800	IE5	95.2	92.0	4500	28.5	78.9	1.8	0.0864	177	B
18.5	M3BL 180MLB 4	3GBL182433-●SC	1800	IE5	95.1	92.6	4500	38.5	98.0	1.5	0.156	222	B
22	M3BL 180MLC 4	3GBL182433-●SC	1800	IE5	95.5	92.6	6000	43.2	117	1.5	0.156	222	B
30	M3BL 200MLB 4	3GBL202423-●SC	1800	IE5	96.0	93.2	4500	57.0	159	1.5	0.287	304	B
37	M3BL 225SMB 4	3GBL222233-●SC	1800	IE5	96.3	93.7	3600	69.3	196	1.5	0.38	385	B
45	M3BL 225SMC 4	3GBL222233-●SC	1800	IE5	96.4	94.3	3600	85.8	239	1.5	0.38	350	B
55	M3BL 250SMB 4	3GBL252223-●SC	1800	IE5	96.4	94.7	3100	102	292	1.5	0.632	454	B
75	M3BL 280SMA 4	3GBL282213-●DC	1800	IE5	96.2	94.7	2600	145	478	2.2	1	639	B
90	M3BL 280SMB 4	3GBL282223-●DC	1800	IE5	96.3	94.7	2600	170	477	2.0	1	639	B
110	M3BL 280SMC 4	3GBL282233-●DC	1800	IE5	96.5	94.8	2600	207	584	2.1	1.21	697	B
110	M3BL 315SMA 4	3GBL312213-●DC	1800	IE5	96.4	94.8	2200	210	584	2.2	1.64	873	B
132	M3BL 315SMB 4	3GBL312223-●DC	1800	IE5	96.5	95.3	2200	255	842	2.2	1.87	925	B
160	M3BL 315SMC 4	3GBL312233-●DC	1800	IE5	96.8	95.3	2200	301	849	2.0	2.04	965	B
200	M3BL 315MLA 4	3GBL312413-●DC	1800	IE5	97.0	95.3	2200	374	1061	2.0	2.45	1116	B
250	M3BL 315LKA 4	3GBL312813-●DC	1800	IE5	96.8	95.3	2200	474	1326	2.2	3.04	1357	B
315	M3BL 315LKC 4	3GBL312833-●DC	1800	IE5	97.0	95.3	2200	570	1671	1.9	3.77	1533	B
1200 r/min (40 Hz)			460 V network										
7.5	M3BL 160MLA 4	3GBL162412-●SC	1200	IE5	93.9	89.7	4500	14.3	59.6	1.9	0.0702	160	B
11	M3BL 160MLB 4	3GBL162422-●SC	1200	IE5	94.4	90.5	4500	21.2	87.5	1.9	0.0864	177	B
15	M3BL 180MLC 4	3GBL182432-●SC	1200	IE5	94.6	90.5	6000	30.5	119	1.5	0.156	216	B
18.5	M3BL 200MLA 4	3GBL202412-●SC	1200	IE5	95.3	92.0	4500	35.1	147	2.3	0.287	304	B
22	M3BL 200MLB 4	3GBL202422-●SC	1200	IE5	95.6	92.0	4500	43.0	175	2.1	0.287	304	B
30	M3BL 225SMB 4	3GBL222222-●SC	1200	IE5	95.9	93.2	3100	56.1	239	1.5	0.38	348	B
37	M3BL 250SMA 4	3GBL252212-●SC	1200	IE5	95.7	93.2	3600	67.0	294	1.7	0.575	428	B
45	M3BL 280SMA 4	3GBL282212-●DC	1200	IE5	96.2	93.7	2600	85.0	358	2.3	1	639	B
55	M3BL 280SMB 4	3GBL282222-●DC	1200	IE5	96.1	93.7	2600	104	438	2.0	1	639	B
75	M3BL 280SMC 4	3GBL282232-●DC	1200	IE5	96.3	94.3	2600	138	715	1.9	1.21	697	B
75	M3BL 315SMA 4	3GBL312212-●DC	1200	IE5	96.8	94.3	2200	143	597	2.1	1.64	873	B
90	M3BL 315SMB 4	3GBL312222-●DC	1200	IE5	96.8	94.3	2200	173	716	2.1	1.87	925	B
110	M3BL 315SMC 4	3GBL312232-●DC	1200	IE5	96.8	94.8	2200	208	875	2.0	2.04	965	B
132	M3BL 315MLA 4	3GBL312412-●DC	1200	IE5	97.2	94.8	2200	240	1050	1.8	2.45	1116	B
160	M3BL 315LKA 4	3GBL312812-●DC	1200	IE5	97.0	94.8	2000	296	1273	2.0	3.04	1357	B
200	M3BL 315LKC 4	3GBL312832-●DC	1200	IE5	97.3	94.8	2000	363	1592	2.0	3.77	1533	B

* Additional motor losses acc. to IEC TS 60034-30-2.

Technical data

High output Synchronous reluctance motors 400 V

High output synchronous reluctance motors, network voltage 400 V

Output, kW	Type designation	Product code	Efficiency class	Speed at 100% of nominal power (M) (r/min)	Motor efficiency with VSD supply	Max speed, n_{max} r/m	Current, I_N A	Torque		Rotor inertia (J = 1/4GD ²) (M) (kgm ²)	Weight, kg
								T_r /Nm	T_{OL}/T_N Nm		
3000 r/min (100 Hz)											
400 V network											
33	M3BL 160MLB 4	3GBL162427-●SB	IE3	3000	93.5	4200	76.7	105	1.5	0.0579	130
40	M3BL 160MLC 4	3GBL162437-●SB	IE3	3000	93.9	4200	92.5	127	1.5	0.0702	157
45	M3BL 160MLE 4	3GBL162457-●SB	IE4	3000	94.6	4200	103	143	1.5	0.0864	174
62	M3BL 200MLA 4	3GBL202417-●SB	IE4	3000	95.2	4200	144	197	1.5	0.242	279
72	M3BL 200MLC 4	3GBL202437-●SB	IE4	3000	95.4	4200	166	229	1.5	0.287	304
97	M3BL 250SMA 4	3GBL252217-●SB	IE4	3000	95.2	3600	224	309	1.5	0.499	396
112	M3BL 250SMB 4	3GBL252227-●SB	IE4	3000	95.3	3600	259	357	1.5	0.575	428
125	M3BL 250SMC 4	3GBL252237-●SB	IE4	3000	95.5	3600	288	398	1.5	0.633	454
2100 r/min (70 Hz)											
400 V network											
25	M3BL 160MLB 4	3GBL162425-●SB	IE3	2100	92.3	2940	58.8	114	1.5	0.0579	130
31	M3BL 160MLC 4	3GBL162435-●SB	IE3	2100	93.0	2940	72.4	141	1.5	0.0702	157
39	M3BL 160MLE 4	3GBL162455-●SB	IE3	2100	93.7	2940	90.4	177	1.5	0.0864	174
44	M3BL 200MLA 4	3GBL202415-●SB	IE3	2100	93.8	2940	102	200	1.5	0.242	279
62	M3BL 200MLC 4	3GBL202435-●SB	IE3	2100	94.0	2940	143	282	1.5	0.287	174
88	M3BL 250SMA 4	3GBL252215-●SB	IE3	2100	95.0	2940	201	400	1.5	0.499	396
98	M3BL 250SMB 4	3GBL252225-●SB	IE4	2100	95.2	2940	224	446	1.5	0.575	428
115	M3BL 250SMC 4	3GBL252235-●SB	IE4	2100	95.5	2940	258	523	1.5	0.633	454
124	M3BL 280SMA 4	3GBL282215-●DB	IE4	2100	95.2	2400	259	564	1.6	0.857	604
134	M3BL 280SMB 4	3GBL282225-●DB	IE4	2100	95.5	2400	279	609	1.7	1	639
160	M3BL 280SMC 4	3GBL282235-●DB	IE4	2100	95.8	2400	329	728	1.7	1.21	697
1500 r/min (50 Hz)											
400 V network											
17	M3BL 160MLB 4	3GBL162423-●SB	IE2	1500	91.2	2100	42.6	108	1.5	0.0579	130
20	M3BL 160MLC 4	3GBL162433-●SB	IE2	1500	92.0	2100	49.2	127	1.5	0.0702	157
25	M3BL 160MLE 4	3GBL162453-●SB	IE3	1500	92.8	2100	58.5	159	1.5	0.0864	174
33	M3BL 200MLA 4	3GBL202413-●SB	IE3	1500	93.2	2100	76.9	210	1.5	0.242	279
40	M3BL 200MLC 4	3GBL202433-●SB	IE3	1500	93.5	2100	92.9	255	1.5	0.287	304
71	M3BL 250SMA 4	3GBL252213-●SB	IE3	1500	94.3	2100	166	452	1.5	0.499	396
86	M3BL 250SMB 4	3GBL252223-●●B	IE3	1500	94.6	2100	184	547	1.5	0.575	428
97	M3BL 250SMC 4	3GBL252233-●SB	IE3	1500	95.0	2100	225	618	1.5	0.633	454
103	M3BL 280SMA 4	3GBL282213-●DB	IE3	1500	94.8	2100	221	656	1.5	0.857	604
118	M3BL 280SMB 4	3GBL282223-●DB	IE3	1500	95.3	2100	246	758	1.5	1	639
134	M3BL 280SMC 4	3GBL282233-●DB	IE4	1500	95.6	1800	279	853	1.7	1.21	697
155	M3BL 315SMA 4	3GBL312213-●DB	IE4	1500	95.7	1800	321	987	1.5	1.64	873
180	M3BL 315SMB 4	3GBL312223-●DB	IE4	1500	96.0	1800	374	1146	1.5	1.87	925
205	M3BL 315SMC 4	3GBL312233-●DB	IE3	1500	96.2	1800	423	1305	1.5	2.04	965
250	M3BL 315MLA 4	3GBL312413-●DB	IE4	1500	96.4	1800	516	1592	1.5	2.45	1116
275	M3BL 315MLB 4	3GBL312423-●DB	IE3	1500	96.5	1800	573	1751	1.6	2.68	1169
315	M3BL 315LKA 4	3GBL312813-●DB	IE4	1500	96.4	1800	659	2005	1.6	3.04	1357
350	M3BL 315LKC 4	3GBL312833-●DB	IE4	1500	96.5	1800	712	2228	1.7	3.77	1533

Variant codes

IE5 Synchronous reluctance motors

Variant codes specify additional options and features to the standard motor. The desired features are listed as three-digit variant codes in the motor order. Note also that there are variants that cannot be used together.

Code/Variants	Frame size							
	132	160	180	200	225	250	280	315
Administration								
529	Customer witnessed visual inspection of complete order line.	•	•	•	•	•	•	•
530	Two-year extension on standard warranty	-	•	•	•	•	•	•
531	Sea freight packing	•	•	•	•	•	•	•
533	Wooden sea freight packing	-	-	-	-	-	•	•
590	Mounting of customer supplied part other than coupling.	-	•	•	•	•	•	•
648	Rating plate in special language	•	•	•	•	•	•	•
684	ABB Ability Smart sensor mounted	-	•	•	•	•	•	•
999	Case specific design requiring a quotation	•	•	•	•	•	•	•
Balancing								
417	Vibration acc. to Grade B (IEC 60034-14).	-	•	•	•	•	•	•
423	Balanced without key.	•	•	•	•	•	•	•
424	Full-key balancing	•	•	•	•	•	•	•
Bearings and Lubrication								
036	Transport lock for bearings.	•	•	•	•	•	•	•
037	Roller bearing at D-end.	•	•	•	•	•	•	•
039	Cold-resistant grease	-	•	•	•	•	•	•
040	Heat-resistant grease	-	•	•	•	•	•	•
041	Bearings regreasable via grease nipples.	•	○	○	○	○	○	○
043	SPM compatible nipples for vibration measurement	•	○	○	○	○	○	○
057	2RS bearings at both ends.	•	•	•	•	•	-	-
058	Angular contact bearing at D-end, shaft force away from bearing.	•	•	•	•	•	•	•
059	Angular contact bearing at N-end, shaft force towards bearing.	•	-	-	-	-	-	•
060	Angular contact bearing at D-end, shaft force towards bearing.	-	-	-	-	-	-	•
061	Angular contact bearing at N-end, shaft force away from bearing.	-	-	-	-	-	-	•
107	Pt100 2-wire in bearings.	-	•	•	•	•	•	•
128	Double PT100, 2-wire in bearings	-	•	•	•	•	•	•
129	Double PT100, 3-wire in bearings	-	•	•	•	•	•	•
194	ZZ bearings greased for life at both ends.	○	•	•	•	•	-	-
420	Bearing mounted PTC thermistors.	-	-	-	-	-	-	•
433	Outlet grease collector	-	-	-	-	-	-	•
506	Nipples for vibration measurement : SKF Marlin Quick Connect stud CMSS-2600-3	-	•	•	•	•	•	•
593	Bearings grease suitable for food and beverage industry.	•	•	•	•	•	•	•
654	Provision for vibration sensors (M8x1)	-	•	•	•	•	•	•
796	Grease nipples JIS B 1575 PT 1/8 Type A	-	•	•	•	•	•	•
797	Stainless steel SPM nipples	•	•	•	•	•	•	•
798	Stainless steel grease nipples	-	•	•	•	•	•	•
799	Grease nipples flat type DIN 3404, thread M10x1	-	•	•	•	•	•	•
800	Grease nipples JIS B 1575 PT 1/8" pin type	-	•	•	•	•	•	•
Branch standard designs								
177	Design for high ambient applications	-	•	•	•	•	•	-
178	Stainless steel / acid proof bolts.	•	•	•	•	•	•	•
204	Jacking bolts for foot mounted motors.	-	•	•	•	•	•	•
209	Non-standard voltage or frequency, (special winding).	•	•	•	•	•	•	•
217	Cast iron D-end shield (on aluminum motor).	•	-	-	-	-	-	-
396	Motor designed for minimum ambient temperature -20 °C to -40 °C, with space heaters (code 450/451 must be added)	-	•	•	•	•	•	•
397	Motor designed for minimum ambient temperature -40 °C to -55 °C, with space heaters (code 450/451 must be added)	-	•	•	•	•	•	•
425	Corrosion protected stator and rotor core.	-	•	•	•	•	•	•
786	Special design shaft upwards (V3, V36, V6) for outdoor mounting.	-	•	•	•	•	•	-
877	Design for high ambient applications, motor without fan and fan cover	-	•	•	•	•	•	-

○ = Included as standard | • = Available as option | - = Not applicable

Code/Variants	Frame size							
	132	160	180	200	225	250	280	315
Cooling system								
053	Metal fan cover.	●	○	○	○	○	○	○
068	Light alloy metal fan	●	●	●	●	●	●	●
075	Cooling method IC418 (without fan).	●	●	●	●	●	●	●
183	Separate motor cooling (fan axial, N-end).	●	●	●	●	●	●	●
206	Steel fan	-	●	●	●	●	●	●
422	Separate motor cooling (on top) with integrated fan motor	-	-	-	-	-	●	●
514	Separate motor cooling (fan on top)	-	-	-	-	-	●	●
791	Stainless steel fan cover	-	●	●	●	●	●	●
Coupling								
035	Assembly of customer supplied coupling-half.	-	-	-	-	-	●	●
Documentation								
141	Binding 2D main dimension drawing.	-	●	●	●	●	●	●
370	Motor model drawing in 3D	-	●	●	●	●	●	●
374	Binding 2D motor detailed drawing	-	●	●	●	●	●	●
536	Photos of manufactured motors	●	●	●	●	●	●	●
722	Rotor dimension drawing (incl. torsional stiffness).	-	●	●	●	●	●	●
Drain holes								
065	Plugged existing drain holes.	●	●	●	●	●	●	●
448	Draining holes with metal plugs.	-	●	●	●	●	●	●
Earthing Bolt								
067	External earthing bolt.	●	○	○	○	○	○	○
525	External earthing bolts on motor feet	-	●	●	●	●	●	●
Heating elements								
450	Heating element, 100-120 V	●	●	●	●	●	●	●
451	Heating element, 200 - 240 V	●	●	●	●	●	●	●
Insulation system								
014	Winding insulation class H.	-	●	●	●	●	●	●
405	Special winding insulation for frequency converter supply.	●	●	●	●	●	●	●
Mounting arrangements								
008	IM 2101 foot/flange mounted, IEC flange, from IM 1001 (B34 from B3).	●	-	-	-	-	-	-
009	IM 2001 foot/flange mounted, IEC flange, from IM 1001 (B35 from B3).	●	●	●	●	●	●	●
047	IM 3601 flange mounted, IEC flange, from IM 3001 (B14 from B5).	●	-	-	-	-	-	-
066	Modified for specified mounting position differing from IM B3 (1001), IM B5 (3001), B14 (3601), IM B35 (2001), IM B34 (2101)	●	●	●	●	●	●	●
200	Flange ring holder.	●	-	-	-	-	-	-
236	Flange FT 165.	●	-	-	-	-	-	-
243	Flange ring FF 215.	●	-	-	-	-	-	-
244	Flange ring FT 215.	●	-	-	-	-	-	-
253	Flange ring FF 265.	●	-	-	-	-	-	-
254	Flange ring FT 265.	●	-	-	-	-	-	-
255	Flange FF 265.	●	-	-	-	-	-	-
305	Additional lifting lugs.	-	●	●	●	●	●	●
Noise reduction								
055	Noise reduction cover for foot mounted motor	-	-	-	-	-	●	●
Painting								
105	Paint thickness report.	-	●	●	●	●	●	●
114	Special paint color, standard grade	●	●	●	●	●	●	●
115	Painting system C4,durability Medium	-	●	●	●	●	●	●
168	Primer paint only.	-	●	●	●	●	●	●
710	Thermally sprayed zink metallizing with acrylic top coat	-	●	●	●	●	●	●
711	Painting system C5, durability High	-	●	●	●	●	●	●
719	Painting system CX	-	●	●	●	●	-	-
754	Painting system C5, durability Medium	-	●	●	●	●	●	●
Protection								
005	Protective roof	●	●	●	●	●	●	●
072	Radial seal at D-end. Not possible for 2-pole , 280 and 315 frames	●	●	●	●	●	●	●
073	Sealed against oil at D-end.	-	●	●	●	●	●	●
158	Degree of protection IP65.	●	●	●	●	●	●	●
250	Degree of protection IP66	-	●	●	●	●	●	●
401	Protective roof, horizontal motor.	-	●	●	●	●	●	●
403	Degree of protection IP56.	●	●	●	●	●	●	●
434	Degree of protection IP56, open deck.	-	-	-	-	-	●	●
783	Labyrinth sealing at D-end.	-	●	●	●	●	●	●
784	Gamma-seal at D-end.	●	○	○	○	○	○	-

○ = Included as standard | ● = Available as option | - = Not applicable

Code/Variants	Frame size							
	132	160	180	200	225	250	280	315
Rating & instruction plates								
002	Restamping voltage, frequency and output, continuous duty.	•	•	•	•	•	•	•
004	Additional text on std rating plate (max 12 digits on free text line).	•	•	•	•	•	•	•
126	Tag plate	-	•	•	•	•	•	•
135	Mounting of additional identification plate, stainless.	•	•	•	•	•	•	•
138	Mounting of additional identification plate, aluminium.	•	-	-	-	-	-	-
139	Additional identification plate delivered loose.	•	•	•	•	•	•	•
159	Additional plate with text "Made in"	•	•	•	•	•	•	•
160	Additional rating plate affixed.	•	•	•	•	•	•	•
161	Additional rating plate delivered loose.	•	•	•	•	•	•	•
163	Frequency converter rating plate. Rating data according to quotation.	•	•	•	•	•	•	•
181	Rating plate with ABB standard loadability values for VSD operation. Other auxiliaries for VSD operation to be selected as necessary.	-	•	•	•	•	•	•
528	Rating plate sticker	-	•	•	•	•	•	•
Shaft & rotor								
069	Two shaft extensions according to catalog drawings.	•	•	•	•	•	•	•
070	Special shaft extension at D-End, standard shaft material	•	•	•	•	•	•	•
131	Motor delivered with half key (key not exceeding shaft diameter)	•	•	•	•	•	-	-
155	Cylindrical shaft extension, D-end, without key-way.	-	•	•	•	•	•	•
164	Shaft extension with closed keyway	○	○	○	○	○	•	•
165	Shaft extension with open keyway	•	•	•	•	•	○	○
410	Shaft material stainless steel	-	-	-	-	-	•	•
591	Special shaft extension according to customer specification.	•	•	•	•	•	•	•
600	Special shaft extension at N-end, standard shaft material.	-	•	•	•	•	•	•
Standards and Regulations								
208	Fulfilling Underwriters Laboratories (UL), listed requirements	-	•	•	•	•	•	•
586	Fulfilling UK Conformity Assessment (UKCA) requirements.	•	•	•	•	•	•	•
823	WIMES 3.03i6 Compliant Design for VSD operation	•	•	•	•	•	•	•
Stator winding temperature sensors								
121	Bimetal detectors, break type (NCC), (3 in series), 130 °C, in stator winding	•	•	•	•	•	•	•
122	Bimetal detectors, break type (NCC), (3 in series), 150 °C, in stator winding	•	•	•	•	•	•	•
123	Bimetal detectors, break type (NCC), (3 in series), 170 °C, in stator winding	•	•	•	•	•	•	•
124	Bimetal detectors, break type (NCC), (3 in series), 140 °C, in stator winding	-	•	•	•	•	•	•
125	Bimetal detectors, break type (NCC), (2x3 in series), 150 °C, in stator winding	•	•	•	•	•	•	•
127	Bimetal detectors, break type (NCC), (3 in series, 130 °C & 3 in series, 150 °C), in stator winding	•	•	•	•	•	•	•
321	Bimetal detectors, closing type (NO), (3 in parallel), 130°C, in stator winding.	•	-	-	-	-	-	-
325	Bimetal detectors, closing type (NO), (2x3 in parallel), 150°C, in stator winding.	•	-	-	-	-	-	-
327	Bimetal detectors, closing type (NO), (3 in parallel, 130°C & 3 in parallel, 150°C), in stator winding.	•	-	-	-	-	-	-
435	PTC - thermistors (3 in series), 130 °C, in stator winding	•	•	•	•	•	•	•
437	PTC - thermistors (3 in series), 170 °C, in stator winding	•	•	•	•	•	•	•
439	PTC - thermistors (2x3 in series), 150 °C, in stator winding	•	•	•	•	•	•	•
440	PTC - thermistors (3 in series, 110°C & 3 in series, 130°C), in stator winding.	•	-	-	-	-	-	-
441	PTC - thermistors (3 in series, 130 °C & 3 in series, 150 °C), in stator winding	•	•	•	•	•	•	•
442	PTC - thermistors (3 in series, 150 °C & 3 in series, 170 °C), in stator winding	-	•	•	•	•	•	•
445	Pt100 2-wire in stator winding, 1 per phase	•	•	•	•	•	•	•
446	Pt100 2-wire in stator winding, 2 per phase	-	•	•	•	•	•	•
502	Pt100 3-wire in stator winding, 1 per phase	-	•	•	•	•	•	•
503	Pt100 3-wire in stator winding, 2 per phase	-	•	•	•	•	•	•
511	PTC thermistors (2 x 3 in series), 130 °C, in stator winding	-	•	•	•	•	•	•
Terminal box								
019	Larger than standard terminal box.	-	-	-	-	-	•	•
020	Detached terminal box.	-	•	•	•	•	•	•
021	Terminal box LHS (seen from D-end).	-	•	•	•	•	•	•
022	Cable entry LHS (seen from D-end).	○	•	•	•	•	•	•
157	Terminal box degree of protection IP65.	-	•	•	•	•	•	•
180	Terminal box RHS (seen from D-end).	-	•	•	•	•	•	•
230	Standard metal cable gland.	•	•	•	•	•	•	•

○ = Included as standard | • = Available as option | - = Not applicable

Code/Variants	Frame size							
	132	160	180	200	225	250	280	315
277	Cable sealing end unit, size small for C-opening	-	-	-	-	-	•	-
278	Cable sealing end unit, size medium for D-opening	-	-	-	-	-	-	•
279	Cable sealing end unit, size large for D-opening	-	-	-	-	-	-	•
292	Adapter C-C	-	-	-	-	-	•	-
293	Adapter D-D	-	-	-	-	-	-	•
294	Adapter E-D	-	-	-	-	-	-	•
295	Adapter E-2D	-	-	-	-	-	-	•
375	Standard plastic cable gland	•	-	-	-	-	-	-
376	Two standard plastic cable glands	•	-	-	-	-	-	-
380	Separate terminal box for temperature detectors, std. material	-	•	•	•	•	•	•
413	Extended cable connection, no terminal box.	-	•	•	•	•	•	•
418	Separate terminal box for auxiliaries, standard material.	-	•	•	•	•	•	•
447	Top mounted separate terminal box for monitoring equipment.	-	-	-	-	-	•	•
466	Terminal box at N-end.	-	•	•	•	•	•	•
468	Cable entry from D-end.	-	•	•	•	•	•	•
469	Cable entry from N-end.	-	•	•	•	•	•	•
554	Cast iron flange for cable glands drilled and tapped according to order.	-	•	•	•	•	•	•
557	Nickel plated cable glands mounted according to order.	-	•	•	•	•	•	•
567	Separate terminal box material: cast Iron	-	○	○	○	○	•	•
568	Separate terminal box for heating elements, std. material	-	•	•	•	•	•	•
569	Separate terminal box for brakes	-	-	-	-	-	•	•
730	Prepared for NPT cable glands.	-	•	•	•	•	•	•
731	Two standard metal cable glands.	•	•	•	•	•	•	•
740	Prepared for PG cable glands.	-	•	•	•	•	-	-
742	Protective cover for accessory terminal block in main terminal box.	-	-	-	-	-	•	•
743	Non-drilled cast iron flange for cable glands	-	•	•	•	•	•	•
744	Stainless steel non-drilled flange for cable glands.	-	-	-	-	-	•	•
745	Painted steel flange equipped with nickel plated brass cable glands	-	-	-	-	-	•	•
746	Stainless steel cable flange equipped with standard nickel plated brass cable glands	-	-	-	-	-	•	•
Testing								
146	Type test with report for one motor from specific delivery batch.	-	•	•	•	•	•	•
148	Routine test report.	•	•	•	•	•	•	•
150	Customer witnessed testing. Specify test procedure with other codes.	-	•	•	•	•	•	•
760	Vibration level test	-	•	•	•	•	•	•
761	Vibration spectrum test for one motor from specific delivery batch.	-	-	-	-	-	•	•
762	Noise level test for one motor from specific delivery batch.	-	•	•	•	•	•	•
763	Noise spectrum test for one motor from specific delivery batch.	-	-	-	-	-	•	•
Variable speed drives								
182	Mounting of non-listed pulse tacho.	•	•	•	•	•	•	•
429	Separate motor cooling (fan top, N-end) and 1024 pulse tacho (Leine & Linde 861) mounted.	-	-	-	-	-	•	•
470	Prepared for hollow shaft pulse tacho (L&L equivalent).	-	•	•	•	•	•	•
472	1024 pulse tacho (L&L 861007455-1024).	-	•	•	•	•	•	•
473	2048 pulse tacho (L&L 861007455-2048).	-	•	•	•	•	•	•
474	Separate motor cooling (axial fan, N-end) and prepared for hollow shaft tacho (L&L equivalent)	-	•	•	•	•	•	•
476	Separate motor cooling (axial fan, N-end) and 1024 pulse tacho (L&L 861007455-1024)	-	•	•	•	•	•	•
477	Separate motor cooling (axial fan, N-end) and 2048 pulse tacho (L&L 861007455-2048)	-	•	•	•	•	•	•
478	Separate motor cooling (fan on top, N-end) and prepared for hollow shaft tacho (L&L equivalent)	-	-	-	-	-	•	•
479	Mounting of other type of pulse tacho with shaft extension, tacho not included.	-	-	-	-	-	•	•
510	Separate motor cooling (fan top, N-end) and 2048 pulse tacho (Leine & Linde 861) mounted.	-	-	-	-	-	•	•
570	Prepared for hollow shaft pulse tacho (L&L 503).	-	•	•	•	•	-	-
588	Shaft grounding device	•	•	•	•	•	-	-
658	Special tacho mounted, price category 1	-	-	-	-	-	•	•
659	Special tacho mounted, price category 2	-	•	•	•	•	•	•
660	Special tacho mounted, price category 3	-	-	-	-	-	•	•
661	1024 Pulse tacho mounted, Hohner series 59, 11-30V	•	-	-	-	-	-	-
662	2048 Pulse tacho mounted, Hohner series 59, 11-30V	•	-	-	-	-	-	-
701	Insulated bearing at N-end.	-	•	•	•	•	○	○
702	Insulated bearings at both ends	•	•	•	•	•	-	-
704	EMC cable entry.	•	•	•	•	•	•	•

○ = Included as standard | • = Available as option | - = Not applicable

Mechanical design

Motor frame and drain holes

—
01 As standard, the motor is delivered with drain holes and closable plugs

Motor frame

Motor size 132 have aluminum alloy stator frame with integrated aluminum feet and terminal box. Motor sizes 160 and above have cast iron frame and feet and a removable terminal box. Integrated feet provide rigid mounting and minimize vibration.

Motors can be supplied for foot mounting, flange mounting, and combinations of these.

Drain holes

Motors that will be operated in very humid or wet environments, and especially under intermittent duty, should be provided with drain holes. The IM designation, such as IM 3031, determines the intended mounting arrangement for the motor.

Motors are fitted with drain holes and closable plugs. The plugs are open on delivery. When mounting the motors, ensure that the drain holes face downwards.

In case of vertical mounting, the upper plug must be hammered home completely. In very dusty environments, both plugs should be hammered home.

When mounting differs from foot-mounted IM B3 arrangement, use variant code 066 when ordering. (See variant code 065 under Drain holes and variant code 066 under Mounting arrangements in the Variant codes section.)

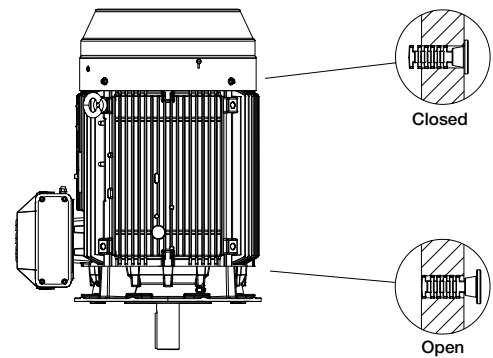
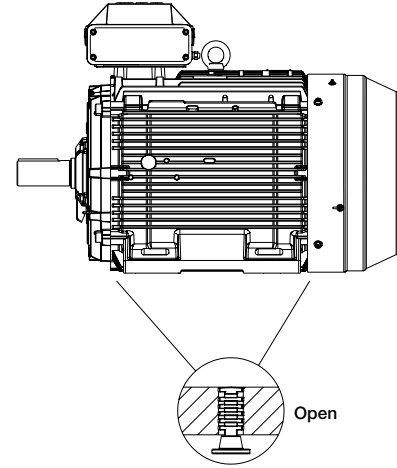

—
01

Mechanical design

Heating elements

Heating elements are installed into windings to keep them free of corrosion in humid conditions. The required power of heating elements is shown in the table. You can order heating elements with variant code 450 or 451.

Motor size	132	160	180	200	225	250	280	315
Heating element power (W)	25	25	50	50	50	50	60	2x60

Mechanical design

Bearings

Standard and alternative bearing designs

Synchronous reluctance motors are normally fitted with single-row deep-groove ball bearings, as shown in the table below.

If the bearing at the D-end is replaced with a roller bearing (NU- or NJ-), higher radial forces can be handled. Roller bearings are suitable for belt-drive applications.

When there are high axial forces, angular-contact ball bearings should be used. This option is available on request. When ordering a motor with an angular-contact ball bearing, specify also the method of mounting and the direction and magnitude of axial force to ensure that the optimal bearing system design is selected. The variant codes for ordering angular-contact ball bearings at D-end are 058 and 060.

Standard and alternative designs

Motor size	n_n r/min	Standard design		Alternative design	
		Deep-groove ball bearings		Roller bearing (VC037)	Angular contact ball bearing (VC058)
		D-end	N-end	D-end	N-end
132	4	6208-2Z/C3	6206-2Z/C3	NU 308 ECP/C3	7208 B
160	4	6309-C3	6209-C3	NU 309 ECP/C3	7209 B
180	4	6310-C3	6209-C3	NU 310 ECP/C3	7210 B
200	4	6312-C3	6210-C3	NU 312 ECP/C3	7312 B
225	4	6312/C3	6210/C3	NU 313 ECP/C3	7313 B
250	4	6315/C3	6213/C3	NU 315 ECP/C3	7315 B
280	4	6316/C3	6316/C3VL0241*	NU 316/C3	7316 B
315	4	6319/C3	6316/C3VL0241*	NU 319/C3	7319 B

* Insulated bearing at N-end as standard.

Axially-locked bearings

All motors are equipped as standard with an axially locked bearing at the D-end.

Transport locking

Motors with roller bearings or an angular-contact ball bearing are fitted with a transport lock before dispatch to prevent damage to bearings during transport. A warning sign is attached to motors larger than 250 when transport locking is used.

Locking may also be fitted in other cases if severe transport conditions are expected.

Bearing seals

These tables present the standard and alternative sizes and types of seals per motor size.

Motor size	n _N r/min	Standard design	
		Axial seal	
		D-end	N-end
132	4	VA40	Labyrinth seal
160	4	RB45	RB45
180	4	RB50	RB45
200	4	RB60	RB50
225	4	RB65	RB50
250	4	RB75	RB65
280	4	Labyrinth sealing	Labyrinth sealing
315 SM, ML	4	Labyrinth sealing	Labyrinth sealing
315 LK	4	Labyrinth seal	Labyrinth sealing

Mechanical design

Bearing life and lubrication

Bearing life

The nominal life L_{10h} of a bearing is defined according to ISO 281 as the number of operating hours achieved or exceeded by 90 % of identical bearings in a large test series under specified conditions. 50 % of bearings achieve at least five times this lifetime.

The calculated bearing life L_{10h} for power transmission by means of coupling is for horizontally mounted motors in sizes 280 to 315 $\geq 200,000$ hours.

Lubrication

On delivery, motors in frame size 225 and above are prelubricated with high-quality grease. Before first start-up, see instructions for relubrication and recommended grease in the Manual for low voltage motors delivered together with the motor, or see the lubrication plate on the motor.

Lubrication intervals

ABB follows the L_1 principle in defining lubrication intervals. According to this principle, 99 % of motors will make the interval time. The synchronous reluctance motor sizes 160 to 315 have regreaseable bearings as the standard solution. The lubrication intervals can also be calculated according to the L_{10} principle, which usually gives twice as long interval times. L_{10} values are available from ABB at request.

Motors with relubrication nipples

In frame sizes 280 – 315, the bearing system allows the use of a valve disc to ease lubrication. Motors are lubricated while running.

The grease outlet opening has closing valves at both ends. These should be opened before greasing and closed 1 – 2 hours after regreasing. This ensures that the construction is tight and bearings remain dust- and dirt-free. A grease-collection method can be used optionally.

The following tables show lubrication intervals according to the L_1 principle for various nominal speeds in 25 °C ambient temperature. These values apply to horizontally mounted motors (B3) with 80 °C bearing temperature and high-quality grease containing lithium-complex soap and mineral or PAO-oil.

Lubrication intervals in duty hours for ball bearings

Frame size	Amount of grease g/DE	Amount of grease, g/NDE	Interval hours at		
			3000 r/min	1500 r/min	1000 r/min
Deep groove ball bearing					
132	Greased for life				
160	13	8	14900	27100	34200
180	15	8	13000	25100	32300
200	20	9	9900	21600	28800
225	23	9	8500	20100	27300
250	30	15	6200	17300	24400
280	40	40		16000	23100
315	55	40		12700	19600

Lubrication intervals in duty hours for roller bearings

Frame size	Amount of grease g/DE	Amount of grease, g/NDE	Interval hours at		
			3000 r/min	1500 r/min	1000 r/min
Cylindrical roller bearing					
132	Greased for life				
160	13	8	7500	13500	17100
180	15	8	6500	12600	16100
200	20	9	4900	10800	14400
225	23	9	4300	10000	13600
250	30	15	3100	8600	12200
280	40	40	-	8000	11600
315	55	40	-	6300	9800

Grease lifetime

Grease lifetime information is relevant for motors equipped with bearings greased for life. Synchronous reluctance motors in frame size 132 is equipped with them, while this is also available as an option for frame sizes 160 - 250.

The standard bearing grease is high-quality grease intended for normal temperatures in dry or humid environments. The normal ambient temperature is 40 °C, in some cases even higher. Refer to the table below to see how temperature affects grease lifetime.

As an optional solution, grease nipples for regreasing can also be provided. See variant code 041.

The grease lifetime L_{10} , applicable to permanently lubricated bearings, is defined as the number of operating hours after which 90 % of bearings are still adequately lubricated. 50 % of the bearings achieve twice the lifetime L_{10} .

40 000 hours should be regarded as the definitive maximum lifetime after which bearings should be replaced. Lifetime is subject to the load conditions of the application run by the motor.

Ambient temperature and grease lifetime

Motor size	Speed r/min	Ambient temperature and grease lifetime					
		25 °C	40 °C	50 °C	60 °C	70 °C	80 °C
132	3000	40 000	31 000	20 000	12 000	6 000	3 000
132	1500	40 000	40 000	40 000	24 000	13 000	7 000
132	1000	40 000	40000	40000	33000	18000	9000
160	3000	40 000	40 000	40 000	26 000	14 000	8 000
160	1500-1000	40 000	40 000	40 000	40 000	40 000	37 000
180	3000	38 000	38 000	38 000	38 000	23 000	13 000
180	1500	40 000	40 000	40 000	32 000	28 000	15 000
200	3000	27 000	27 000	27 000	24 000	14 000	8 000
200	1500-1000	40 000	40 000	40 000	40 000	40 000	30 000

Mechanical design

Radial forces

Permissible loading on the shaft

The following table shows permissible radial forces on the shaft in Newtons, assuming zero axial force, a 25 °C ambient temperature, and normal conditions. The values are given for a calculated bearing life of 20 000 and 40 000 hours per motor size.

These calculated values further assume mounting position IM B3 (foot-mounted), with force directed sideways. In some cases, the strength of the shaft affects permissible forces.

Permissible loads of simultaneous radial and axial forces can be supplied on request.

If the radial force is applied between points X0 and Xmax, the permissible force F_R can be calculated with the following formula:

$$F_R = F_{X0} - \frac{X}{E} (F_{X0} - F_{Xmax})$$

Where:

E: length of the shaft extension in the standard version

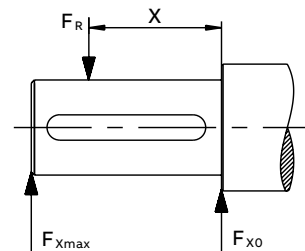

Permissible loading on the shaft

Permissible radial forces, motor sizes 90 – 315

Motor size	Speed r/min	Length of shaft extension E (mm)	Ball bearings				Roller bearings			
			20 000 hours		40 000 hours		20 000 hours		40 000 hours	
			F_{X0} (N)	F_{Xmax} (N)	F_{X0} (N)	F_{Xmax} (N)	F_{X0} (N)	F_{Xmax} (N)	F_{X0} (N)	F_{Xmax} (N)
132	3000	80	2120	1610	2120	1610	-	-	-	-
132	1500	80	2120	1610	2120	1610	-	-	-	-
160	3000	110	3540	2740	2955	2285	7100	4300	6140	4300
160	1500	110	4000	3100	3325	2570	8000	4300	6870	4300
160	1000	110	4170	3200	3440	2655	8600	4300	7270	4300
180	3000	110	4100	3385	3455	2825	8125	5500	7025	5500
180	1500	110	4270	3485	3525	2885	8600	5500	7300	5500
180	1000	110	4700	3800	3855	3155	9400	5500	7900	5500
200	3000	110	5600	4685	4700	3925	10900	9100	9470	9700
200	1500	110	6285	5200	5240	4370	12500	9550	10700	8900
200	1000	110	6800	5700	5700	4770	13600	9550	11670	9550
225	3000	110	6400	5400	5355	4500	13300	10700	11500	9700
225	1500	140	7300	5900	6155	4970	15400	10250	13200	10250
225	1000	140	7600	6200	6370	5140	16400	10250	14000	12500
250	3000	140	7700	6285	6500	5285	17100	10900	14900	10900
250	1500	140	8700	7000	7300	5900	19800	13800	17000	13800
250	1000	140	8900	7200	7355	5955	21200	13800	18000	13800
280	1500	140	9200	7800	7300	6200	25100	9200	20300	9200
280	1000	140	10600	8900	8400	7000	28300	9200	23000	9200
315 SM_	1500	170	11400	9400	9000	7450	32500	9600	26600	9600
315 SM_	1000	170	13000	9600	10300	8500	37000	9600	30000	9600
315 ML_	1500	170	11500	9700	9100	7650	32700	13600	26500	13600
315 ML_	1000	170	13200	11100	10400	8800	36900	13600	29900	13600
315 LK_	1500	170	11500	10000	9100	7850	33100	13350	26800	13350
315 LK_	1000	170	13200	11400	10450	9050	37300	13350	30300	13350

Mechanical design

Axial forces

—
01 Mounting arrangement IM B3

02 Mounting arrangement IM V1

The following tables present permissible axial forces on the shaft in Newton's, assuming zero radial force, a 25 °C ambient temperature, and normal conditions. The values are given for a calculated bearing life of 20 000 and 40 000 hours per motor size.

Permissible loads of simultaneous radial and axial forces can be supplied on request. For axial force F_{AD} , it is assumed that the D-bearing is locked with a locking ring.

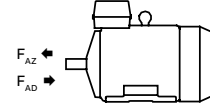

—
01

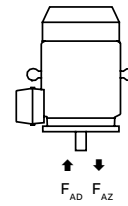

—
02

Permissible axial forces, motor sizes 90 – 315

Motor size	Speed, r/min	Length of shaft extension E (mm)	Mounting arrangement IM B3				Mounting arrangement IM V1			
			Ball bearings				Ball bearings			
			20,000 h		40,000 h		20,000 h		40,000 h	
F_{AD} (N)	F_{AZ} (N)	F_{AD} (N)	F_{AZ} (N)	F_{AD} (N)	F_{AZ} (N)	F_{AD} (N)	F_{AZ} (N)			
132	3000	80	2245	1645	1760	1160	2460	1505	1970	1015
132	1500	80	2595	1980	2025	1425	2815	1850	2245	1280
160	3000	110	4650	4650	3850	3850	4950	4350	4200	3600
160	1500	110	5000	5000	4200	4200	5450	4650	4600	3800
160	1000	110	4840	4840	4000	4000	5400	4420	4540	3560
180	3000	110	5480	5480	4600	4600	5920	5515	5060	4255
180	1500	110	4360	4360	3540	3540	5080	3860	4240	3020
180	1000	110	3990	3990	2820	2820	5240	3780	4060	2610
200	3000	110	5000	7350	5000	6150	5000	7050	5000	5800
200	1500	110	5000	8050	5000	6700	5000	7550	5000	6200
200	1000	110	5000	8300	5000	6880	5000	7505	5000	6025
225	3000	110	4860	4860	3960	3960	5000	4245	4780	3345
225	1500	140	4820	4820	3470	3470	6770	4320	5420	2960
225	1000	140	5960	5960	4210	4210	7910	5450	6160	3700
250	3000	140	6000	6050	4900	4900	6000	5300	5800	4200
250	1500	140	6000	7100	5800	5800	6000	6300	6000	4900
250	1000	140	6000	7480	6000	6040	6000	6370	6000	4830
280	1500	140	8000	6000	6250	4250	9600	4550	7800	2750
280	1000	140	7250	9250	7150	5150	11150	5500	9000	3350
315 SM_	1500	170	9400	7400	7250	5250	11750	5500	9500	3300
315 SM_	1000	170	10 900	8900	8350	6350	13600	6300	11 050	3750
315 ML_	1500	170	9250	7250	7100	5100	12 500	5500	10 300	2900
315 ML_	1000	170	10650	8650	8100	6100	14 900	5800	12 350	3250
315 LK_	1500	170	9100	7150	7000	5000	13 100	3850	10900	1700
315 LK_	1000	170	10 500	8500	7950	5950	15700	4100	13100	1550

Terminal box

Standard terminal box

Degree of protection and mounting options

The degree of protection for the standard terminal box is IP 55. By default, terminal boxes are mounted on top of the motor at the D-end. In motor size 132, the terminal box is integrated in the motor frame. On request, the terminal box can also be mounted on the left or right side regardless of the motor size (see Mounting options).

Turnability

The standard terminal boxes for motor sizes 160–315 can be turned 4*90° after delivery. For motors in size 132, a 4*90° turnable terminal box is optional - this can be ordered with variant code 400.

Cable entries

The terminal box is provided with tapped holes for cable glands. No cable glands are included as standard, the entry holes are closed with blanking plugs made of plastic. Very large motors have an angle adapter between the terminal box and the cable gland. Please refer to the table on the next page for further information about the amount and size of threaded holes, plugs and cable sealing units provided as standard.

Different types of cable glands are available as an option. Please refer to the terminal box alternatives section for more details.

Cable type and terminations If no cable type is specified in the order, it will be a PVC-insulated non-armored cable, and its termination parts are determined as shown in the following table.

Terminations are suitable for copper and aluminum cables. Cables are connected to terminals by cable lugs, which are not included in the delivery.

Cable entries

Standard terminal box connections

Motor size	Speed r/min	Terminal box type	Size of flange opening	Amount and size of threaded plugged holes	Plugged holes	Max. connectable core cross-section mm ² /phase	Number and size of terminal bolts	Earthing in the main terminal box
132	1500, 3000	Integrated	-	2xM32x1.5	2xM32	1x10	6xM5	M4
160	1000-3000	63	B	2xM40x1.5	2xM40	1x35	6xM6	M6
180	1500-3000	63	B	2xM40x1.5	2xM40	1x35	6xM6	M6
200	1500-3000	160	C	2xM63x1.5	2xM63	1x70	6xM10	M6
225	3000	160	C	2xM63x1.5	2xM63	1x70	6xM10	M6
250	1000-3000	160	C	2xM63x1.5	2xM63	1x70	6xM10	M6
280	1000-1500	210	C	2xM63	2xM63	2x150	6xM12	2xM10
315 SM, ML	1000-1500	370	D	2xM63x1,5	2xM63	2x240	6xM12	2xM10
315 LKA, LKC	1000-1500	750*	E	2xM75x1,5	1xM75	4x240	6xM12	2xM10

* With adapter E-D and medium size end unit

Auxiliary cable entries

132	1500, 3000	2xM12
160-250	1000-3000	2xM20x1.5
280-315	1000-1500	2xM20x1.5

Shaft height	Earthing on frame
132	M5
160 - 250	M6 (with clamp)
280-315	M10

Standard delivery if no other information is provided.

Ordering

To ensure the delivery of desired terminations for the motor, state the cable type, quantity, size and outer diameter when ordering. Non-standard designs of terminal boxes, such as non-standard size, or higher degree of protection, are available as options.

See section Variant codes for all options available.

Terminal box

Terminal box dimensions

01 Terminal box type 63 and 160

02 Terminal box types 210 and 370

03 Terminal box type 750 + adapter

For dimensions of integrated terminal boxes in aluminum motors, size 132, see the following Dimension drawings pages.

To match the correct terminal box with motor sizes 160 - 315, find the motor type and correspondent terminal box type on the previous page. The box types and their dimensions are presented on this page.

Frame dimensions

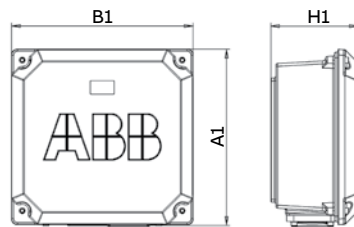

01

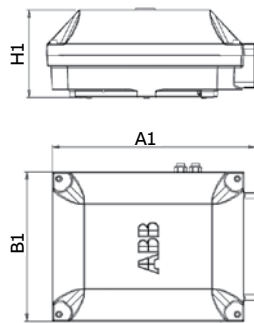

02

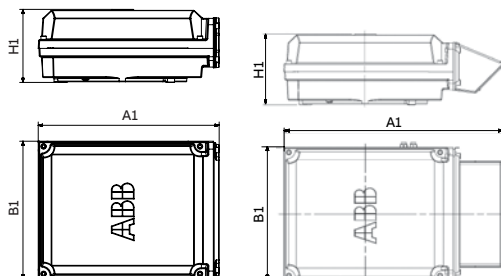

03

Terminal box types	A1	B1	H1	Gland plate opening
63	248	248	109	B
160	291	302	154	C
210	416	306	177	C
370	451	347	200	D
750 with E-D adapter	686	413	219	D
750 without E-D adapter	523	413	219	E
750 with E-2D adapter	826	413	219	2xD

Dimensions for terminal box inlets

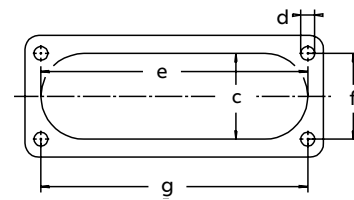

Flange opening	c mm	e mm	f mm	g mm	d thread type
B	71	194	62	193	M8
C	62	193	62	193	M8
D	100	300	80	292	M10
E	115	370	100	360	M12

Cable glands

The motors are delivered as standard with plugged cable entries or cable sealing units as described in the previous section. There is available a broad selection of different type of cable glands, which are suitable for different types of cable and outer diameter ranges.

Size of threaded opening for cable gland	Cable gland(s) nickel plated brass, variant code 230 or 731	EMC Cable gland(s) nickelplated brass, variant code 704	Cable gland(s) plastic, variant code 375 or 376
	Cable outer diameter, mm	Cable outer diameter, mm	Cable outer diameter, mm
M16 x 1.5	4–12	4–8	4–12
M20 x 1.5	4–12	4–12	4–12
M25 x 1.5	10–18	10–18	10–18
M32 x 1.5	14–24	14–24	14–24
M40 x 1.5	22–32	22–32	22–32
M50 x 1.5	26–35	26–35	26–35
M63 x 1.5 ¹⁾	35–45	35–45	35–45
M75 x 1.5	46–62	46–62	not available

Threaded openings for cable glands with NPT thread (variant code 730)

The standard delivery for the motors are provided with openings for cable glands with metric threads as listed in the section describing the standard terminal box. If NPT threads will be needed, the variant code 730 is to be ordered. If nothing else is stated on the order, the sizes in tables below will be delivered.

Motor frame size	Main cable entries	NPT plug
132	2 x ¾"	1 x ¾"
160–180	2 x 1 ¼"	1 x 1 ¼"
200–250	2 x 1 ½"	1 x 1 ½"
280	2 x 2"	1 x 2"
315	2 x 3"	1 x 3"

Motor frame size	Cable entries for auxiliaries	NPT plug
132	1 x ¾"	1 x ¾"
160–315	2 x ¾"	2 x ¾"

Gland plates with threaded openings for cable glands of nonstandard size

If the standard size of threaded openings for cable glands is not suitable then nonstandard size openings are also available, either by fitting the reducers to make the openings smaller or by increasing the amount or size of holes. The maximum possible size and amount for each gland plate size is listed below. Threaded openings of non-standard size can be ordered by using variant codes 554 and 727.

Gland plate size	Maximum amount and size of threaded holes
B	2 x M40
C	2 x M63
D	2 x M90 or 3 x M75
E	2 x M90 or 4 x M75

Terminal box

Terminal boxes and boards

—
01 Integrated terminal box for motor size 132. Knock-out openings for cable entries

02 Terminal board for motor size 132

03 Terminal box for motor sizes 160 – 250. Connection flanges with tapped cable entries

04 Terminal board for 160 – 250

05 Terminal box for motor sizes 280 - 315, except LKA and LKC. Connection flange with tapped cable entries

06 Terminal board for motor sizes 280 - 315, except LKA and LKC

07 Terminal box for motor sizes 315 LKA and LKC

08 Terminal board for 315 LKA and LKC

The pictures below show standard terminal boxes and the corresponding terminal boards for various motor sizes.

Motor size 132



—
01



—
02

Motor sizes 160 – 250

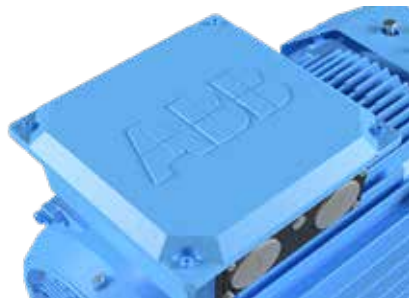

—
03



—
04

Motor sizes 280 – 315



—
05



—
06



—
07



—
08

Terminal box

Terminal box alternatives

01 Main terminal box

02 Adapters, Flange with glands; cable sealing end units



01

Optional adapters

There is a broad selection of cable termination accessories available to allow termination of one or several cables. The most common ones are explained below.

How to order

- Check first that the terminal box itself allows mounting of the desired cable and cores (refer to motor type and terminal box type cross reference on previous page)
- If very large cables are used it might be necessary to use a larger terminal box than standard. Select the right cable gland(s) or cable sealing end unit(s) that match outer diameter of the cable(s)
- Select appropriate adapter or flange
- Note that turning the terminal box to a non-standard position might limit the use of some adapters.

Ordering example for special cable entry and auxiliary terminal box

Motor Cables	250 kW, 1500 rpm, 400 V 50 Hz 2 pieces, outer diameter 58 mm, single core cross section 185 mm ² clamping device needed, cables coming from below
Needed one terminal box for anticondensation heaters and another for temperature detectors, material must be cast iron.	
Motor	M3BL 315 MLA, 1500 rpm, B3
Adapter	D-D - variant code 293
Cable sealing end unit	Variant code 278
Clamping	Variant code 231
Auxiliaries	Variant codes 380, 567, 568



02

Main terminal box and maximum single core cross-section



The terminal boxes are named according to their current-carrying capacity, from 120 to 1200. You can select one size larger than standard terminal box if a larger single cross-section is needed. The standard sizes of the main terminal box are listed in the following table. Check also the capacity of the cable entry to make sure that the cables fit. A larger terminal box can be ordered with variant code 019.

Standard terminal box	Large terminal box	Size of opening	Max single cross-section mm ² / phase
120	210	B	1 x 70
210	370	C	2 x 240
370	750	D	2 x 300
750	1200	E	4 x 500
1200	-	-	-

Terminal box

Optional adapters

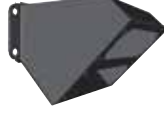

To allow easy termination of cables entering the terminal box from above or below, an angle adapter is recommended. These are available for motor sizes 280 - 315 and can also be used to allow the mounting of several cable sealing end units or gland plates.

Adapater				
Variant code	292	293	294	295
Suited for motor sizes	280 with gland plate opening C in the terminal box.	280-315 with gland plate opening D in the terminal box.	315 with gland plate opening E in the terminal box.	315 with gland plate opening E in the terminal box.
Opening to terminal box	C	D	E	E
Flange or opening for end unit	C	D	D	2 x D
Material	Cast iron	Cast iron	Cast iron	Steel
Notes				Included in type 750 terminal box when 750 is the standard size.

Cable sealing end units

As an alternative to flanges and cable glands, cable sealing end units can be used. These allow more space for spreading the cores for easy termination. Cable sealing end units have rubber-sealed entries for one of the two main cables. In addition, there are two plugged M20 holes for auxiliary cables.

Please note that the table below is only for guidance. Due to the large amount of combinations possible between terminal box sizes, end units and adapters, not all possible combinations can be described. Please contact your ABB sales office for more detailed information.

	Small	Medium	Large
End unit			
Variant code	277	278	279
Suited for motor sizes	280	315	315
Opening to terminal box	C	D	D
Cable outer diameter	1 - 2 cables, 48 - 60 mm	1 - 2 cables, 48 - 60 mm	1 - 2 cables, 60 - 80 mm
Cable entry for auxiliary cable	2×M20 plugged holes	2 x M20 plugged holes	2 x M20 plugged holes
Additional optional variants	EMC cable gland (704)	EMC cable gland (704)	EMC cable gland (704)

Auxiliary terminal box

You can equip motors from frame size 160 upward with one or several auxiliary terminal boxes for connection of auxiliaries like heaters or temperature detectors. The standard auxiliary terminal box material for motor sizes 280 - 315 is aluminum and for 160 - 250 cast iron. For frame sizes 280 - 315, cast iron as box material is also available as an option.

Connection terminals are of a spring-loaded type for quick and easy connection. These are suitable for up to 2.5 mm² wires. Auxiliary terminal boxes for frame sizes 280 – 315 are equipped with an earthing terminal. The first auxiliary terminal box is located on the right-hand side at D-end as standard. The standard cable entry size is M20 for both aluminum and cast iron, and the number of entries depends on the terminal box type and the number of selected auxiliaries.

The standard cable entry size is M20 for both aluminum and cast iron, and the number of entries depends on the terminal box type and the number of selected auxiliaries.

Related variant codes	
380	Separate terminal box for temperature detectors, standard material
418	Separate terminal box for auxiliaries, standard material
567	Separate terminal box material: cast iron
568	Separate terminal box for heating elements, standard material
569	Separate terminal box for brake



Small auxiliary aluminum terminal box for motor sizes 280 - 315 (variant codes 418, 568, 380, 569).

The size of terminal box ordered with these codes depends on the number of accessories ordered. 80 x 125 mm, max 12 strips. Earthing size M4.



Large auxiliary aluminum terminal box for motor sizes 280 - 315.

The size of terminal box ordered with these codes depends on the number of accessories ordered. 80 x 250 mm, max 30 strips. Earthing size M4.



Auxiliary cast iron terminal box

Frame size for motor sizes 160 - 250 (variant code 418): 111 x 162 mm, max. 18 strips. No earthing.



Frame size for motor sizes 280 - 315 (variant code 567): 208 x 180 mm, max 30 strips. Earthing size M6.



Small auxiliary aluminum terminal box for motor size 132 (variant code: 418): 80 x 75 mm, max 8 strips. Earthing size M4.

Dimension drawings

Synchronous reluctance (SynRM) motors

Foot-mounted motor IM 1001, IM B3

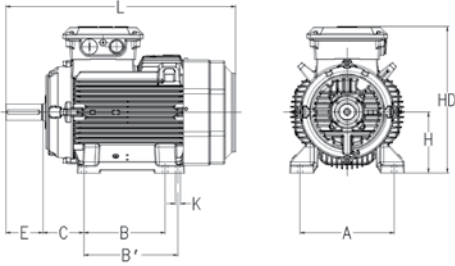

Flange-mounted motor IM 3001, IM B5

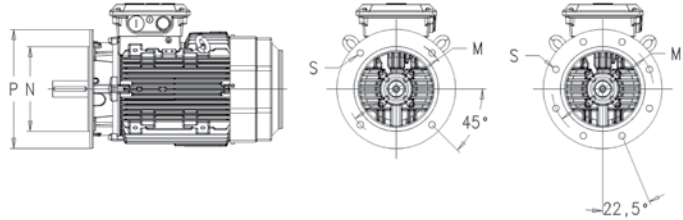

Main dimensions for IE5 SynRM motors (C-generation)

Motor size	Speed r/min	IM1001, IMB3 and IM3001, IM1001, IMB3											IM B5 (IM3001)				IM B14 (IM 3601), IM 3602						
		IMB5																					
		D	GA	F	E	L	A	B	B1	C	H	HD	K	M	N	P	S	T	M	N	P	S	T
		max					max																
132 SMA-D	3000	38	41	10	80	487	216	140	178	89	132	109.5	12	265	230	300	14.5	4	165	130	200	M10	3.5
132 SMA-B	1500	38	41	10	80	550	216	140	178	89	132	321	12	265	230	300	14.5	4	165	130	200	M10	3.5
132 SMC	1500	38	41	10	80	590	216	140	178	89	132	321	12	265	230	300	14.5	4	165	130	200	M10	3.5
160 MLA-C	3000	42	45	12	110	584	254	210	254	108	160	421	14.5	300	250	350	19	5	300	250	350	19	5
160 MLA-B	1500-1000	42	45	12	110	681	254	210	254	108	160	421	14.5	300	250	350	19	5	300	250	350	19	5
180 MLB	3000-1500	48	51.5	14	110	726	279	241	279	121	180	461	14.5	300	250	350	19	5	300	250	350	19	5
180 MLB-C	1500-1000	48	51.5	14	110	766	279	241	279	121	180	461	14.5	300	250	350	19	5	300	250	350	19	5
200 MLA-F	3000-1000	55	59	16	110	821	318	267	305	133	200	528	18.5	350	300	400	19	5	350	300	400	19	5
225 SMB	3000	55	59	16	110	879	356	286	311	149	225	573	18.5	400	350	450	19	5	400	350	450	19	5
225 SMB-C	3000-1000	60	64	16	110	879	356	286	311	149	225	573	18.5	400	350	450	19	5	400	350	450	19	5
250 SMA-C	3000	60	64	18	140	884	406	311	349	168	250	626	24	500	450	550	19	5	500	450	550	19	5
250 SMA,B,F,G	1500-1000	65	69	18	140	884	406	311	349	168	250	626	24	500	450	550	19	5	500	450	550	19	5
280	1500-1000	75	79.5	20	140	1088	457	368	419	190	280	762	24	500	450	550	23	5	500	450	550	23	5
315 SM_	1500-1000	80	85	22	170	1204	508	406	457	216	315	852	28	600	550	660	23	6	600	550	660	23	6
315 ML_	1500-1000	90	95	25	170	1315	508	457	508	216	315	852	28	600	550	660	23	6	600	550	660	23	6
315 LK_	1500-1000	90	95	25	170	1521	508	508	560	216	315	880	28	600	550	660	23	6	600	550	660	23	6

¹⁾ Terminal box 370

²⁾ Terminal box 750

The table gives the main dimension in mm. For detailed drawings please see our web page <https://new.abb.com/motors-generators>.

Dimension drawings

Synchronous reluctance (SynRM) motors

Foot-mounted motor IM 1001, IM B3

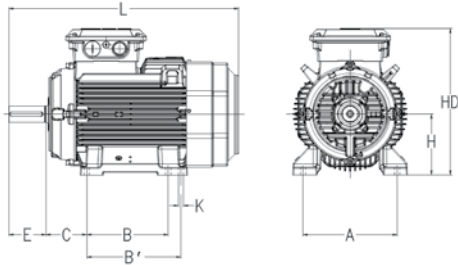

Flange-mounted motor IM 3001, IM B5

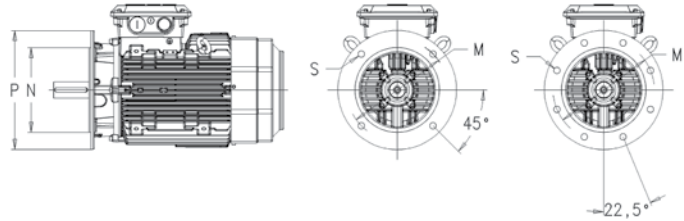

Main dimensions for High output SynRM motors (B-generation)

Motor size	Speed r/min	IM1001, IMB3 and IM3001, IMB5					IM1001, IMB3							IM B14 (IM 3601), IM 3602									
		D	GA	F	E	L max	A	B	B1	C	HD ¹⁾	HD ²⁾	K	M	N	P	S	T	M	N	P	S	T
132 SMB-D	1500-3000	38	41	10	80	487	216	140	178	89	295.5	-	12	265	230	300	14,5	4	165	130	200	M10	3,5
132 SME-F	1500-3000	38	41	10	80	550	216	140	178	89	321	-	12	265	230	300	14,5	4	165	130	200	M10	3,5
160 MLB	1500-3000	42	45	12	110	584	254	210	254	108	460	-	14,5	300	250	350	19	5	300	250	350	19	5
160 MLC, MLE	1500-3000	42	45	12	110	681	254	210	254	108	460	-	14,5	300	250	350	19	5	300	250	350	19	5
200	1500-3000	55	59	16	110	821	318	267	305	133	514	-	14,5	350	300	400	19	5	350	300	400	19	5
250	3000	60	64	18	140	884	406	311	349	168	626	-	24.0	500	450	550	19	5	500	450	550	19	5
250	1500-2100	65	69	18	140	884	406	311	349	168	626	-	24.0	500	450	550	19	5	500	450	550	19	5
280	1500-2100	75	79.5	20	140	1088	457	368	419	190	762	-	24,0	500	450	550	18	5	500	450	550	18	5
315 SM_	1500	80	85	22	170	1204	508	406	457	216	852	880	28	600	550	660	23	6	600	550	660	23	6
315 ML_	1500	90	95	25	170	1315	508	508	560	216	852	880	28	600	550	660	23	6	600	550	660	23	6
315 LK_	1500	90	95	25	170	1521	508	457	508	216	852	880	28	600	550	660	23	6	600	550	660	23	6

¹⁾ Terminal box 370

²⁾ Terminal box 750

The table gives the main dimension in mm. For detailed drawings please see our web page <https://new.abb.com/motors-generators>.

Motors in brief

Synchronous reluctance cast iron frame motors, sizes 132 – 315

Motor size		132	160	180	200	225	250	280	315	
Stator and end shields	Material	Die-cast aluminum alloy	Cast iron							
	Paint color shade	Munsell blue 8B 4.5/3.25								
	Corrosion class	C3								
Bearings	D-end	6308-2Z/C3	6309/C3	6310/C3	6312/C3	6313/C3	6315/C3	6316/C3	6319/C3	
	N-end	6306-2Z/C3	6209/C3	6209/C3	6210/C3	6210/C3	6213/C3	6316/C3*	6316/C3*	
Axially locked bearings	Inner bearing cover	Locked at D-end								
Bearing seals	D-end	V-ring	Gamma-ring					Labyrinth seal		
	N-end	Labyrinth sea	Gamma-ring					Labyrinth seal		
Lubrication		Permanent grease lubrication	Regreasable bearings, regreasing nipples M6×1					Regreasable bearings, regreasing nipples M10x1		
Measuring nipples for condition monitoring of the bearings		Not included	Included							
Rating plate	Material	Aluminum	Stainless steel							
Terminal box	Frame and cover	Aluminum	Cast iron							
	Corrosion class	Die-cast aluminum alloy, integrated in stator	C3							
	Cover screws	Zinc-electroplated steel								
Connections	Cable entries	2x(M40, M32, M12/ 2X(M25, M20)	2x(M40x1.5, M20x1.5)	2x(M63x1.5, M20x1.5)						
	Terminals	6 terminals for connection with cable lugs (not included)								
	Cable glands	Integrated knock-out openings, no cable glands	Cable flange included, glands as option							
Fan	Material	Glass-fiber-reinforced polypropylene								
Fan cover	Material	Polypropylene	Steel							
	Paint color shade	Munsell blue 8B 4.5/3.25								
	Corrosion class	-	C3							
Stator winding	Material	Copper								
	Insulation	Insulation class F								
	Winding protection	3 pcs PTC thermistors as standard								
Balancing method		Half-key balancing								
Keyway		Closed keyway						Open keyway		
Drain holes		Drain holes with closable plastic plugs, open on delivery								
Enclosure		IP 55, higher protection on request								
Cooling method		IC 411								

* Insulated bearing at N-end as standard.

ABB Access



With ABB Access, you can unlock all aspects of your drives, motors or PLCs, from one central location, the palm of your hand.

Simply scan the QR code on the ABB product to get started

ABB Access helps you easily find up-to-date product online data. It also provides easy access to documentation and manuals. If you happen to experience issues with your ABB product, this can be fastly and easily reported online to reach expert support from ABB.

- Device information - Easy Access to detailed product information and EcoDesign data
- Documentation - Quick Access to user manuals and step-by-step instructions
- Report issues - Fast Access to online issue reporting
- Contact - Access ABB contacts and search Channel partners



Total product offering

Motors and generators with a complete portfolio of services



IEC motors

- Low voltage motors
- High voltage induction and synchronous motors
- Marine motors
- Motors for explosive atmospheres
- Motors for food and beverage
- Motors for variable speed drives
- Permanent magnet motors
- Synchronous reluctance motors

NEMA motors

- Low voltage motors
- High voltage induction and synchronous motors
- Marine motors
- Motors for explosive atmospheres
- Motors for variable speed drives
- Permanent magnet motors
- Servomotors
- Washdown motors

Generators

- Generators for wind turbines
- Generators for diesel and gas engine power plants
- Generators for steam and gas turbine power plants
- Generators for marine applications
- Generators for industrial applications
- Generators for traction applications
- Synchronous condensers for reactive power compensation

Life cycle services

ABB's portfolio of drives

Optimal solution for you



Being able to rely on the continuous high performance and efficiency of your operations is something you want to take for granted. ABB variable-frequency drives are made with all this in mind, established upon more than 40 years of experience and backed by a broad range of life cycle services.

ABB drives help you to optimize your processes and systems with state-of-the-art motor control technology, resulting in increased energy efficiency, better product quality, and reduced operating costs with higher output, less downtime, and reduced need for maintenance. All ABB drives are designed for easy selection, ordering, installation and use, and they offer integrated safety features, giving you more time to focus on what matters for you and your business.

Our portfolio offers low-voltage AC and DC drives, medium-voltage AC drives, and motion control drives spanning the fractional-kilowatt to multi-megawatt power level. There is a drive available for essentially every industry and application and for all types of motors, in environments ranging from water utility facilities to clean electrical rooms, and to harsh coal mines and windy offshore platforms to food and beverage production. This wide product range allows you to select the best-fitting drive solution, providing maximum reliability and efficiency for every need.

—
For more information and contact details:

www.abb.com/motors&generators