

Effective: August 1988  
Supersedes I.L. 41-133.2E, Dated November 1980

( ) Denotes Change Since Previous Issue

# Type IRQ

## Directional Overcurrent

## Negative Sequence Relay for

## Ground Protection



**It is recommended that the user of this equipment become acquainted with the information in this instruction leaflet before energizing the relay. Failure to do so may result in injury to personnel or damage to the equipment, and may affect the equipment warranty.**

**The relay contains static sensitive components. Electrostatic Discharge (ESD) precautions must be practiced when handling printed circuit boards and components. Use of anti-static handling materials and grounding procedures is required.**

**Before putting relay into service, remove all blocking which may have been inserted for the purpose of securing the parts during shipment. Operate the relay to check the settings and electrical contacts.**

### 1.0 APPLICATION

The type IRQ is a directional overcurrent ground relay in which the directional unit operates on negative sequence current and voltage, and the overcurrent units operate on residual (or ground) current. The negative sequence current and voltage are obtained by means of self-contained negative sequence filters connected between the directional unit and the current and voltage transformers.

The relay is intended for use at locations where the present equipment or system conditions do not permit the use of the conventional types of directional ground relays operating entirely on residual current and voltage.

At an ungrounded substation on a grounded system where only two potential transformers are available, or where the current and potential transformers are on the opposite side of a wye-delta or delta-wye power transformer bank from the protected line, the type IRQ relay is applicable for ground protection. Note that protected line residual current must be supplied to the overcurrent units.

### 2.0 CONSTRUCTION AND OPERATION

The type IRQ relay consists of a directional cylinder unit (D) operating on negative sequence quantities, negative-sequence current and voltage filters, an auxiliary switch (CS-1 or TR-1), a time-overcurrent unit (CO), an instantaneous overcurrent unit (I), and two indicating contactor switches (ICS/I) and (ICS/T). The principle component parts of the relay and their location are shown in Figures 1 and 2.

#### 2.1. Directional Unit (D)

The directional unit is a product induction cylinder type unit operating on the interaction between the polarizing circuit flux and the operating circuit flux.

Mechanically, the directional unit is composed of four basic components; A die-cast aluminum frame, an electromagnet, a moving element assembly, and a molded bridge.

The frame serves as the mounting structure for the magnetic core. The magnetic core which houses the lower pin bearing is secured to the frame by a locking nut. The bearing can be replaced, if necessary, without having to remove the magnetic core from the frame.

**All possible contingencies which may arise during installation, operation or maintenance, and all details and variations of this equipment do not purport to be covered by these instructions. If further information is desired by purchaser regarding this particular installation, operation or maintenance of this equipment, the local ABB Inc. representative should be contacted**

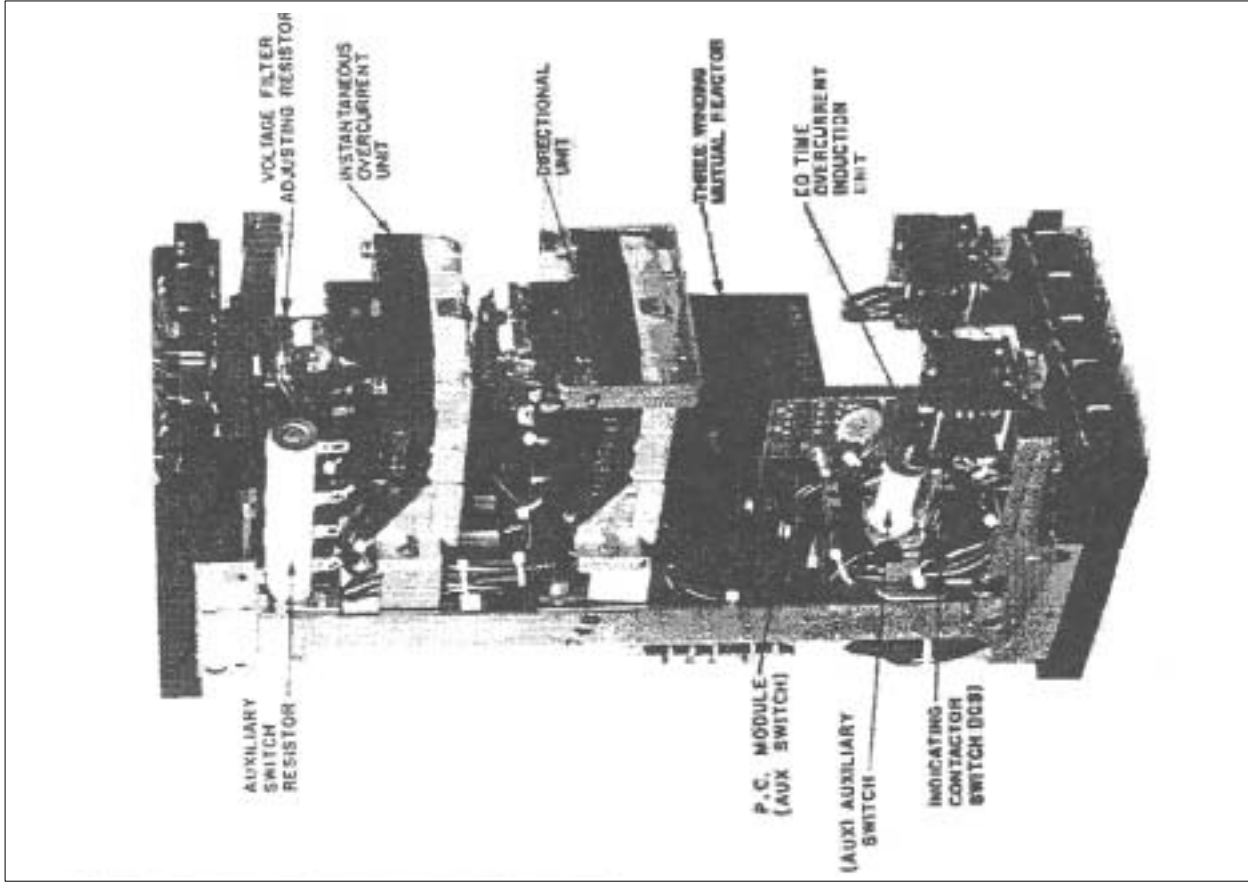

\*Figure 2. Type IRQ Relay without Case (Front View)

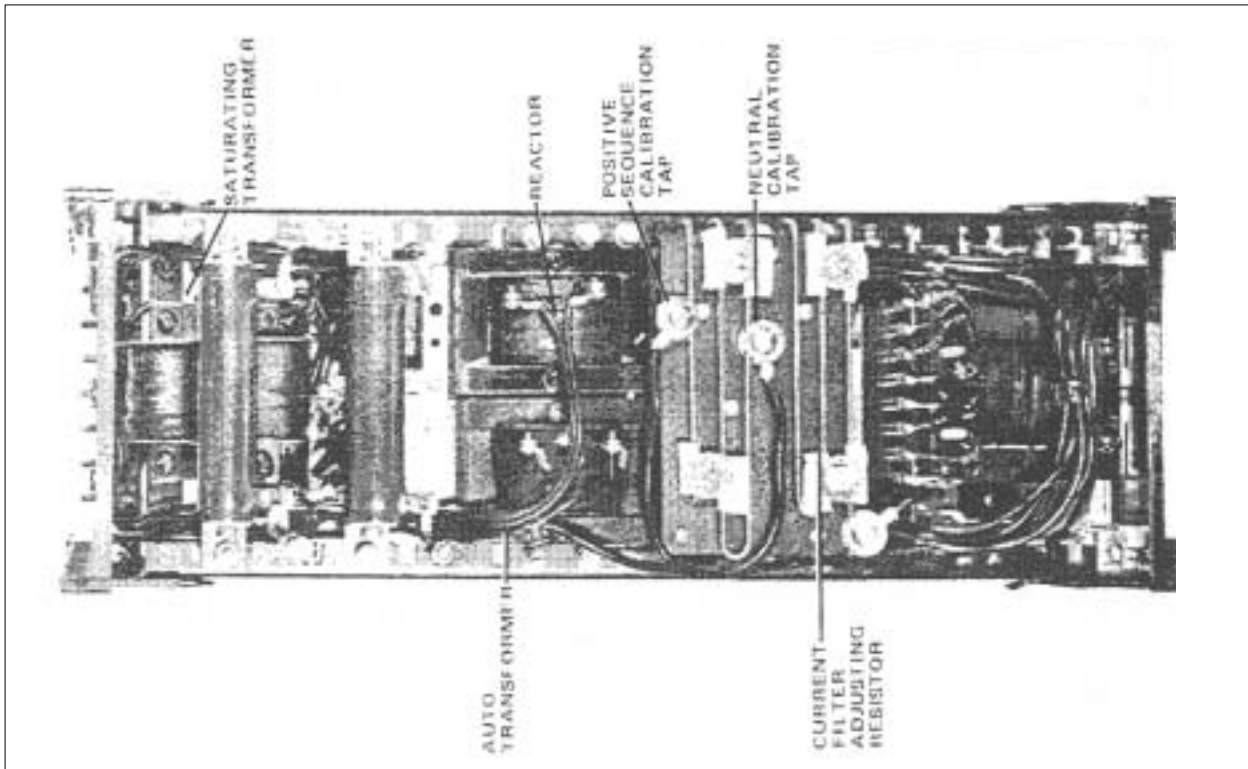

Figure 1. Type IRQ Relay without Case (Rear View)

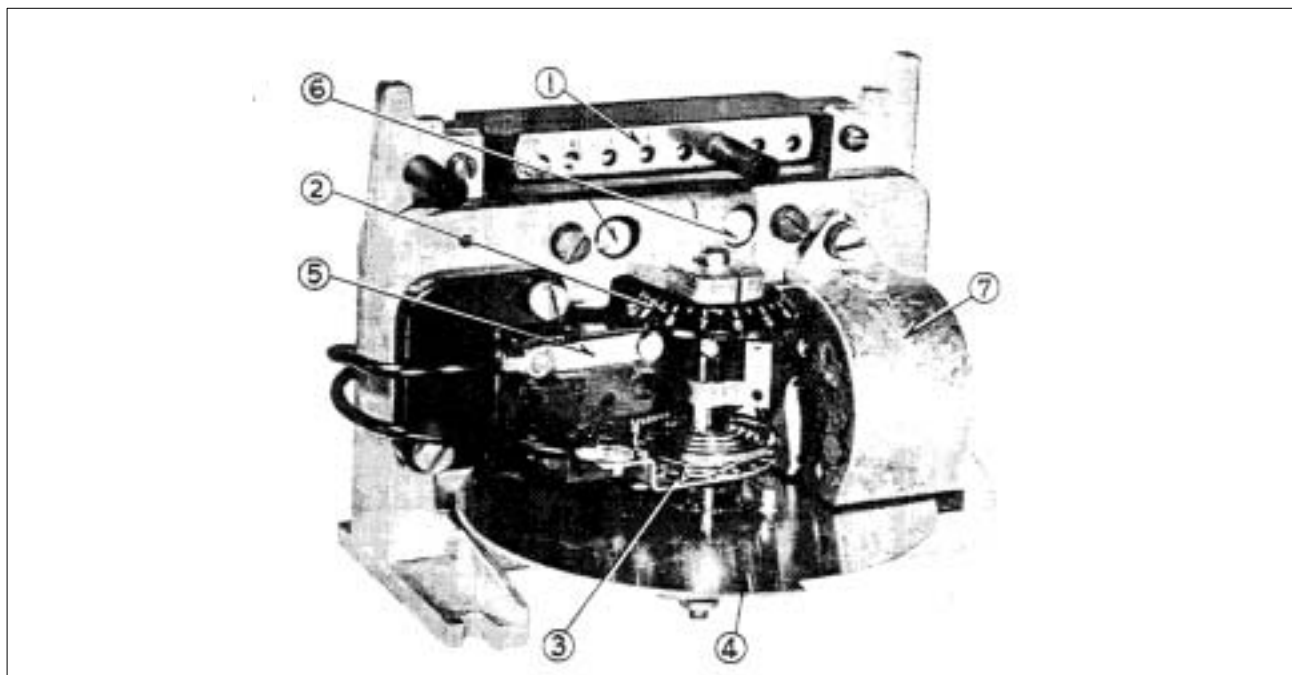

Figure 3 .Time Overcurrent Unit (Front View). 1)Tap Block, 2) Time Dial, 3) Control Spring Assembly, 4) Disc, 5) Stationary Contact Assembly, 6) Magnetic Plugs, 7) Permanent Magnet

The electromagnet has two series-connected polarizing coils mounted diametrically opposite one another; two series-connected operating coils mounted diametrically opposite one another; two magnetic adjusting plugs; upper and lower adjusting plug clips, and two locating pins. The locating pins are used to accurately position the lower pin bearing, which is mounted on the frame, with respect to the upper pin bearing, which is threaded into the bridge. The electromagnet is secured to the frame by four mounting screws.

The moving element assembly consists of a spiral spring, contact carrying member, and an aluminum cylinder assembled to a moulded hub which holds the shaft. The shaft has removable top and bottom jewel bearings. The shaft rides between the bottom pin bearing and the upper pin bearing with the cylinder rotating in an air gap formed by the electromagnet and the magnetic core.

The bridge is secured to the electromagnet and frame by two mounting screws. In addition to holding the upper pin bearing, the bridge is used for mounting the adjustable stationary contact housing. The stationary contact housing is held in position by a spring type clamp. The spring adjuster is located on

the underside of the bridge and is attached to the moving contact arm by a spiral spring. The spring adjuster is also held in place by a spring type clamp.

With the contacts closed, the electrical connection is made through the stationary contact housing clamp, to the moving contact, through the spiral spring out to the spring adjuster clamp.

## 2.2. Negative Sequence Filter

The current and voltage filters consist of reactors and resistors connected together as shown in the internal schematic (Figure 4).

## 2.3. Time-Overcurrent Unit (CO)

The electromagnets for the types IRQ-5, IRQ-6, IRQ-7, IRQ-8 and IRQ-9 relays have a main tapped coil located on the center leg of an "E" type laminated structure that produces a flux which divides and returns through the outer legs. A shading coil causes the flux through the left leg to lag the main pole flux. The out-of-phase fluxes thus produced in the air gap cause a contact closing torque.

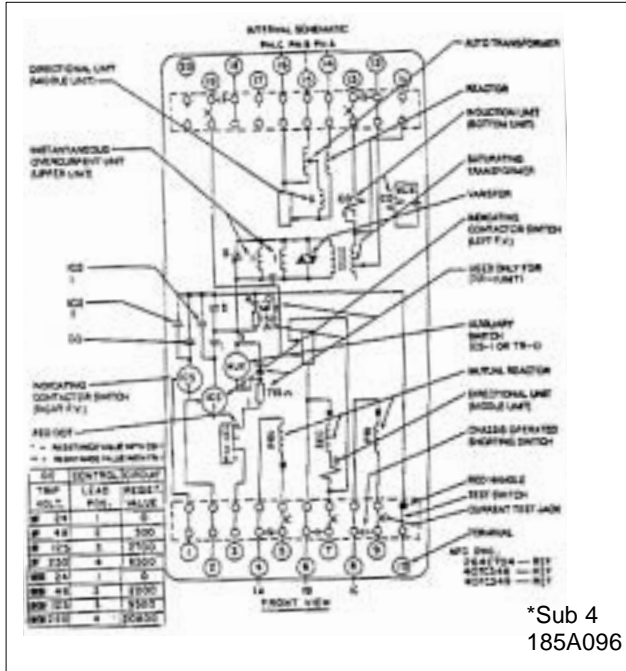

Figure 4. Internal Schematic of the IRQ Relay

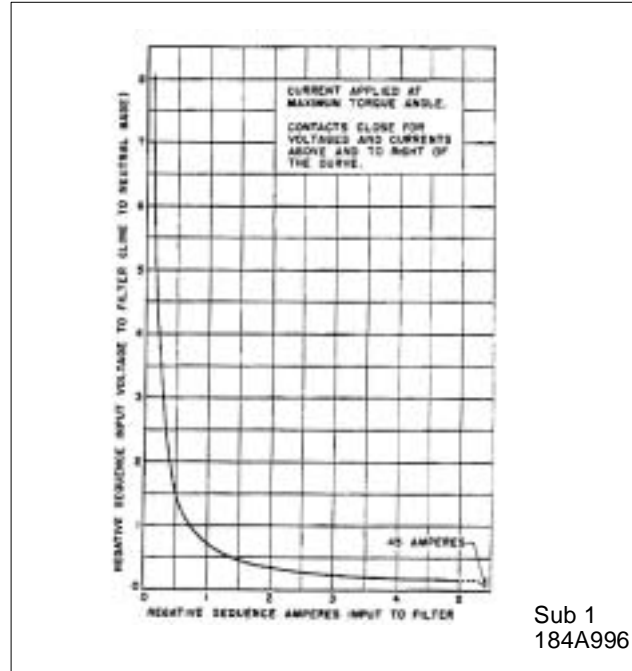

Figure 5 .Sensitivity Curve of the Directional Unit (D)

The electromagnet for the type IRQ-2 and IRQ-11 relays has a main coil consisting of a tapped primary winding and a secondary winding. Two identical coils on the outer legs of the lamination structure are connected to the main coil secondary in a manner so that the combination of all the fluxes produced by the electromagnet result in out-of-phase fluxes in the air gap. The out-of-phase air gap fluxes produced cause a contact closing torque.

**2.4. Auxiliary Switch (CS-1 or TR-1)**

The CS-1 switch is a small solenoid type dc switch. A cylindrical plunger, with a silver disc mounted on its lower end, moves in the core of the solenoid. As the plunger travels upward, the disc bridges the silver stationary contacts. The TR-1 is a telephone type relay. A tapped resistor is used to enable one to use the auxiliary switch on a 24, 48, 125 or 250 volt dc system connected per Figure 14. The operation of the CS-1 or TR-1 switch is controlled by the directional unit (D) which in turn directionally controls the time-overcurrent unit (CO). When sufficient power flows in the tripping direction, the aux switch operates and bridges the lag coil of the time-overcurrent unit (CO) permitting this unit to operate.

**2.5. Instantaneous Overcurrent Unit (I)**

The instantaneous overcurrent unit consists of an induction cylinder type unit and a transformer. The induction cylinder unit is similar in construction to the directional unit. The time phase relationship of the two air gap fluxes necessary for the development of torque is achieved by means of a capacitor connected in series with one pair of pole windings.

The normally-closed contact of the directional unit is connected across one pair of pole windings of the instantaneous overcurrent unit as shown in the internal schematics. This arrangement short-circuits the operating current around the pole windings, preventing the instantaneous overcurrent unit from developing torque. If the directional unit should pick up for a fault, this short circuit is removed, allowing the instantaneous overcurrent contact to commence closing almost simultaneously with the directional contact for high speed operation.

The transformer is one of the saturating type for limiting the energy to the instantaneous overcurrent unit at higher values of fault current and to reduce ct burden. The primary winding is tapped and these taps are brought out to a tap block for ease in changing the pickup of the instantaneous overcurrent unit. The use of a tapped transformer provides approximately

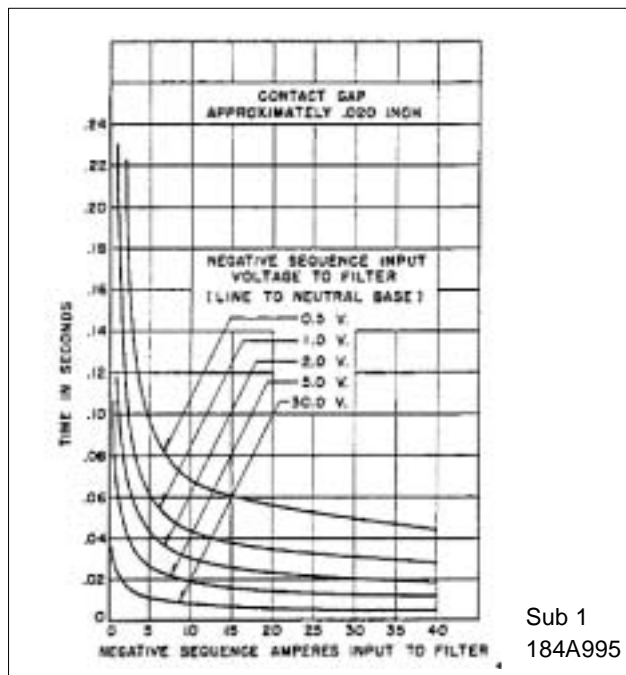

Sub 1  
184A995

Figure 6 .Time Curve of the Directional Unit (D)

the same energy level at a given multiple of pickup current for any setting, resulting in a single time curve throughout the range of the relay.

Across the secondary is connected a non-linear resistor known as a varistor. The effect of the varistor is to reduce the voltage peaks applied to the overcurrent unit and phase shifting capacitor.

### 2.6. Indicating Contactor Switch Unit (ICS/I and ICS/T)

The dc indicating contactor switch is a small clapper type device. A magnetic armature, to which leaf-spring mounted contacts are attached, is attracted to the magnetic core upon energization of the switch. When the switch closes the moving contacts bridge two stationary contacts, completing the trip circuit. Also during this operation two fingers on the armature deflect a spring located on the front of the switch, which allows the operation indicator target to drop.

The front spring, in addition to holding the target, provides restraint for the armature and thus controls the pickup value of the switch.

### 3.0 CHARACTERISTICS

The time characteristics of the time overcurrent

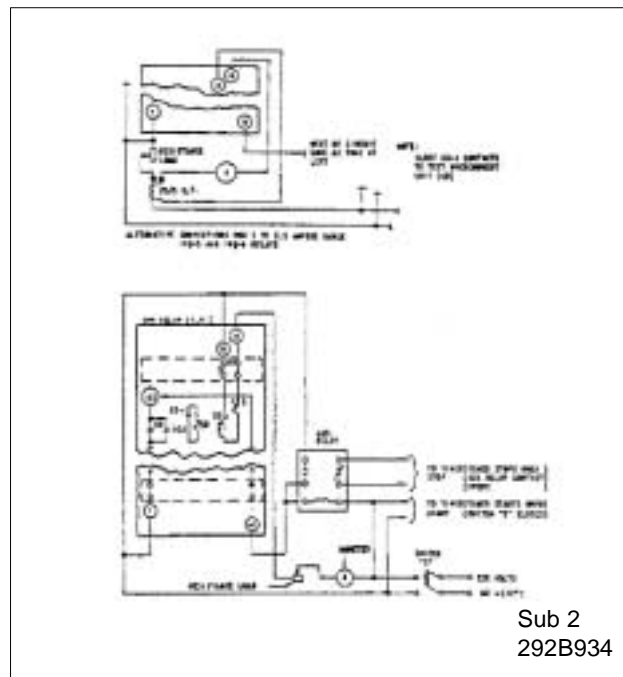

Sub 2  
292B934

Figure 7. Diagram of Test Connections of the Circuit Closing Time Overcurrent Unit of the IRQ Relay

relays are designated by specific numbers as indicated in the following chart (e.g., IRQ-8).

Time Characteristics	Designation
Short Time	2
Long Time	5
Definite Time	6
Moderately Inverse Time	7
Inverse Time	8
Very Inverse Time	9
Extremely Inverse Time	11

The relays are available in the following current ranges:

Time Overcurrent Unit							
Range	Taps						
.5 - 2.5	0.5	0.6	0.8	1.0	1.5	2.0	2.5
2 - 6	2	2.5	3	3.5	4	5	6
4 - 12	4	5	6	7	8	10	12

The time vs. current characteristics for the time overcurrents unit are shown in Figures 15 to 21. These characteristics give the contact closing time for the various time dial settings when the indicated multiples of tap value current are applied to the relay.

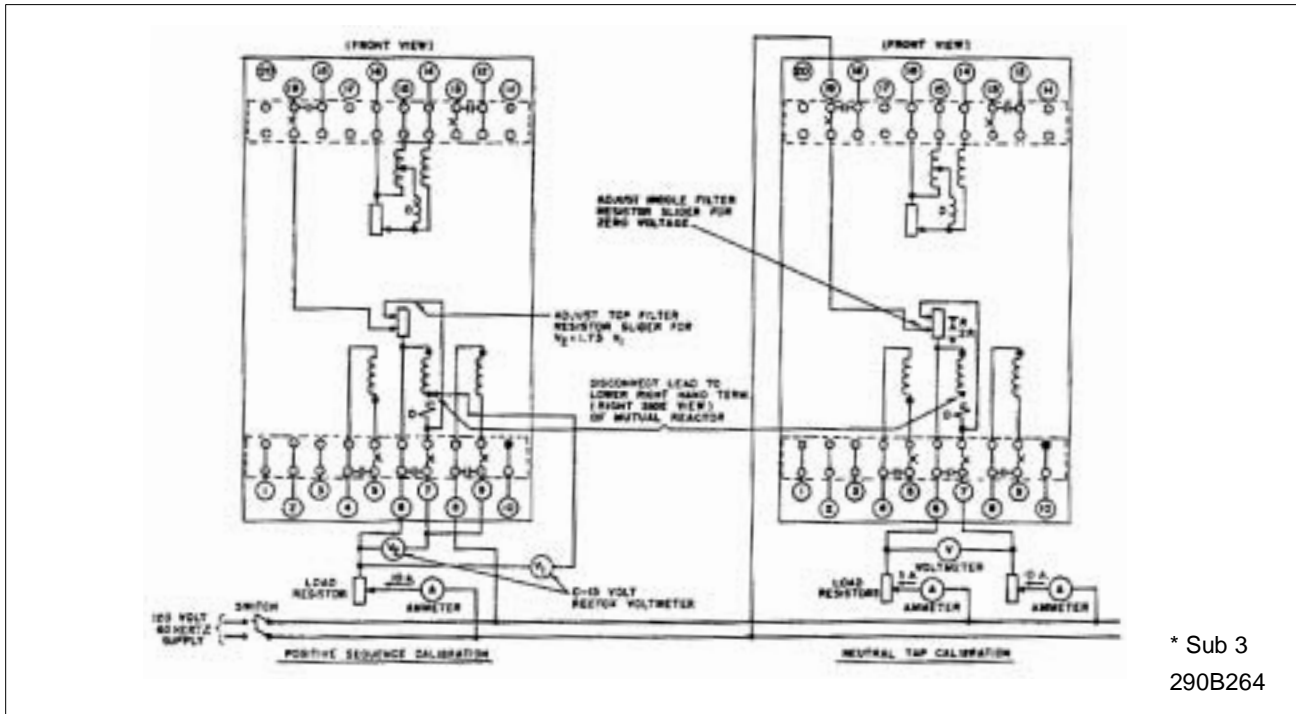

Figure 8. Test Diagram for Calibration of the Negative Sequence Current Filter in the IRQ Relay

INSTANTANEOUS OVERCURRENT UNIT (I)						
RANGE	TAPS					
0.5 - 2 AMPS	0.5	0.75	1.0	1.25	1.5	2
1 - 4	1.0	1.5	2.0	2.5	3.0	4.0
2 - 8	2	3	4	5	6	8
4 - 16	4	6	8	9	12	16
10 - 40	10	15	20	24	30	40
20 - 80	20	30	40	48	60	80

The tap value is the minimum current required to just close the relay contacts.

The time vs., current characteristics for the instantaneous overcurrent unit is shown in Figure 13.

**3.1. Directional Unit (D)**

The directional unit minimum pickup is approximately 0.76 volt-amperes (e.g., 0.19 volt and 4 amperes) in terms of negative sequence quantities applied at the relay terminals at the maximum torque angle of approximately 98° (current leading voltage).

A typical sensitivity curve for the negative sequence directional unit is shown in Figure 5.

The time vs., current characteristics for the directional unit is shown in Figure 6.

**3.2. Trip Circuit**

The relay contacts will safely close 30 amperes at 250 volts dc and the seal-in contacts of the indicating contactor switches will safely carry this current long enough to trip a circuit breaker

The indicating contactor switch has two taps that provide a pickup setting of 0.2 or 2 amperes. To change taps requires connecting the lead located in front of the tap block to the desired setting by means of a screw connection.

**3.3. Cylinder Unit Contacts**

The moving contact assembly has been factory adjusted for low contact bounce performance and should not be changed.

The set screw in each stationary contact has been factory adjusted for optimum follow and this adjustment should not be disturbed.

**3.4. Trip Circuit Constants**

Indicating Contactor Switch

- 0.2 ampere taps - 6.5 ohms dc resistance
- 2.0 ampere taps - 0.15 ohm dc resistance

The auxiliary switch operating time is approximately 5 milliseconds.

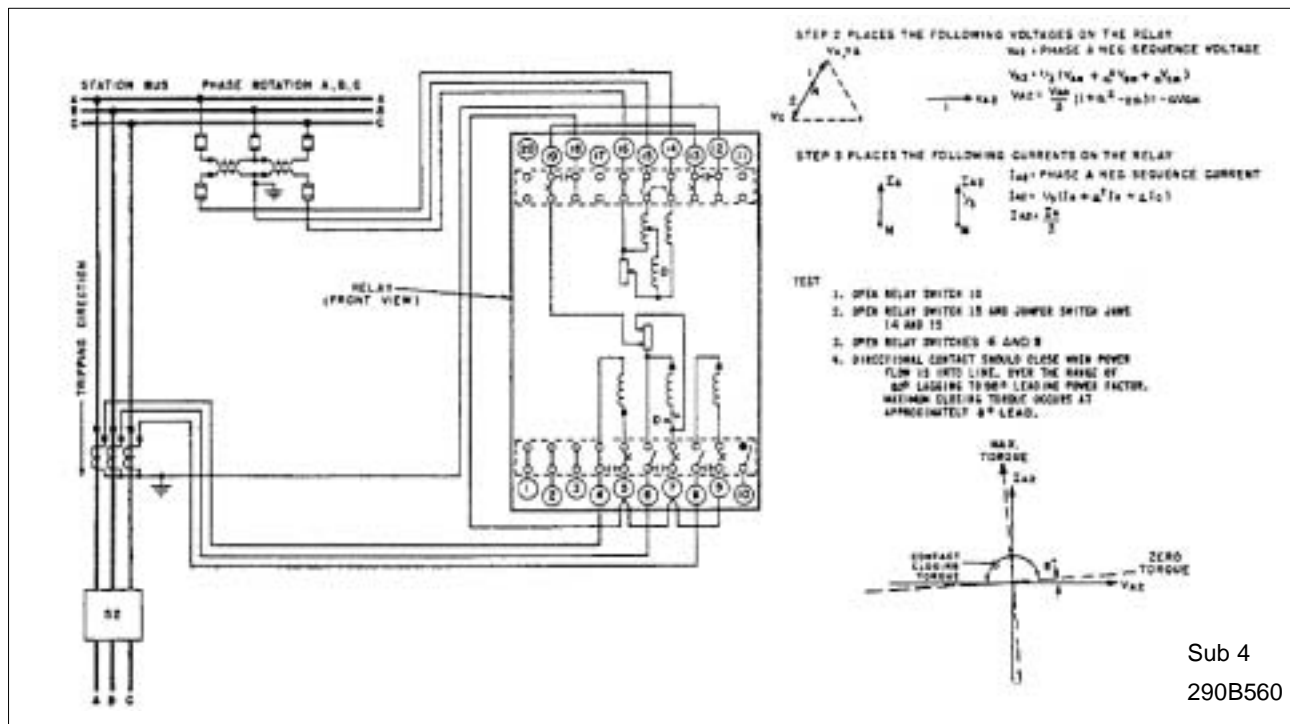

Figure 9 .In Service Test Procedure for Verifying Proper External Connections  
Where CT Neutral is Formed Within the Relay.

dc resistance: 1165 ohms for CS-1  
1500 ohms for TR-1



## 4.0 SETTINGS

### 4.1. Directional Unit (D)

No setting is required.

### 4.2. Time Overcurrent Unit (CO)

The time overcurrent unit settings can be defined either by tap setting and time dial position or by tap setting and a specific time of operation at some current multiple of the tap setting (for example, 4 tap setting, 2 time dial position or 4 tap setting, 0.6 seconds at 6 times tap value current).

To provide selective circuit breaker operation, a minimum coordinating time of 0.3 seconds plus circuit breaker time is recommended between a relay being set and the relays with which coordination is to be effected.

The connector screws on the tap plate above the time dial makes connections to various turns on the operating coil. By placing this screw in the various tap plate holes, the relay will just close its contacts at the corresponding current in amperes, or as marked on the tap plate.

Since the tap block connector screw carries operating current, be sure that the screw is turned tight.

### 4.3. Instantaneous Reclosing

The factory adjustment of the CO unit contacts provides a contact follow. Where circuit breaker reclosing will be initiated immediately after a trip by the CO contact, the time of the opening of the contacts should be a minimum. This condition is obtained by loosening the stationary contact mounting screw, removing the contact plate and then replacing the plate with the bent end resting against the contact spring. With this change and the contact mounting screw tightened, the stationary contact will rest solidly against its backstop.

### 4.4. Instantaneous Overcurrent Unit (I)

The only setting required is the pickup current setting which is made by means of the connector screw located on the tap plate. By placing the connector screw in the desired tap, the relay will just close its contacts at the tap value current.

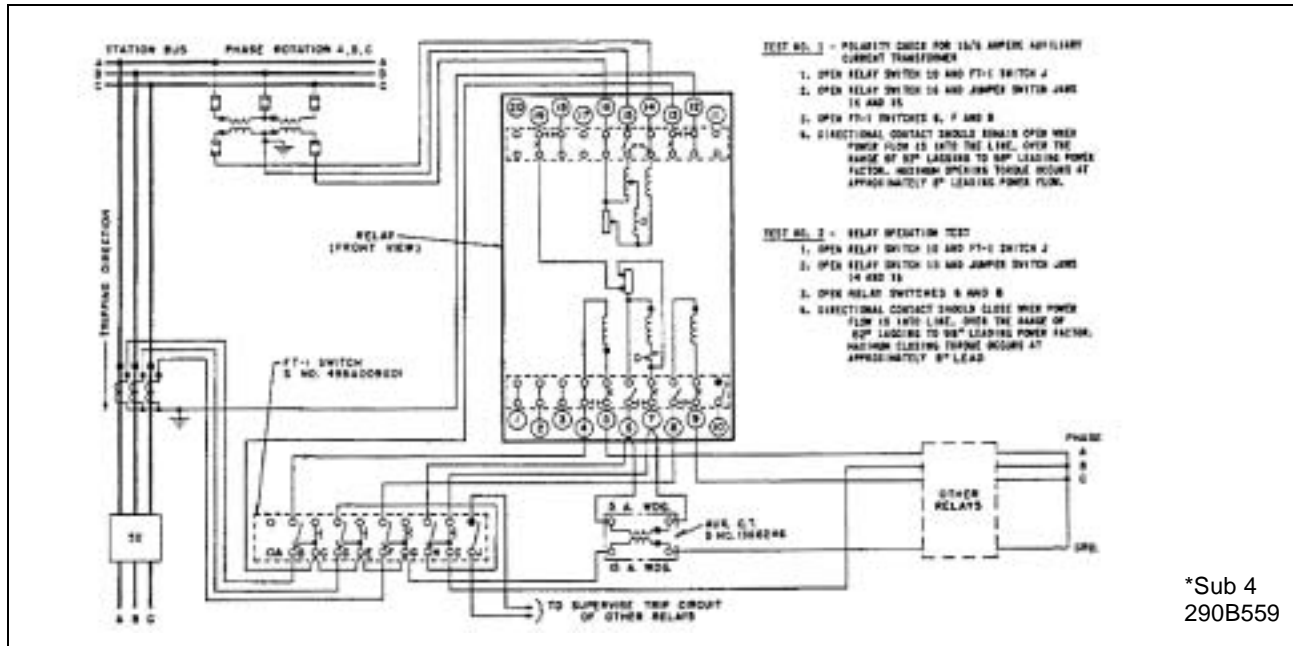

\*Sub 4  
290B559

Figure 10 .In Service Test Procedure for Verifying Power External Connections Where CT Neutral is Formed Externally.



Since the tap block connector screw carries operating current, be sure that the screw is turned tight.

**4.5. Negative Sequence Filter**

No setting is required.

**4.6. Indicating Contactor Switch (ICS/I and ICS-T)**

The only setting required on the ICS units is the selection of the 0.2 or 2.0 ampere tap setting. This selection is made by connecting the lead located in front of the tap block to the desired setting by means of the connecting screw.

**4.7. Auxiliary Switch (CS-1 or TR-1)**

The only setting required on the aux unit is the selection of the required 24, 48, 125 or 250 voltage on the tapped resistor. This connection can be made by referring to Figure 14.

**5.0 INSTALLATION**

The relays should be mounted on switchboard panels or their equivalent in a location free from dirt,

moisture, excessive vibration and heat. Mount the relay vertically by means of the rear mounting stud or studs for the type FT projection case or by means of the four mounting holes on the flange for the semi-flush type FT case. Either the stud or the mounting screws may be utilized for grounding the relay. External toothed washers are provided for use in the locations shown on the outline and drilling plan to facilitate making a good electrical connection between the relay case, its mounting screws or studs as required for poorly grounded or insulating panels. Other electrical connections may be made directly to the terminals by means of screws for steel panel mounting or to the terminal stud furnished with the relay for thick panel mounting. The terminal stud may be easily removed or inserted by locking two nuts on the stud and then turning the proper nut with a wrench.

For detail information on the FT case refer to I.L. 41-076.

The external connections of the directional overcurrent relay are shown in Figure 12.



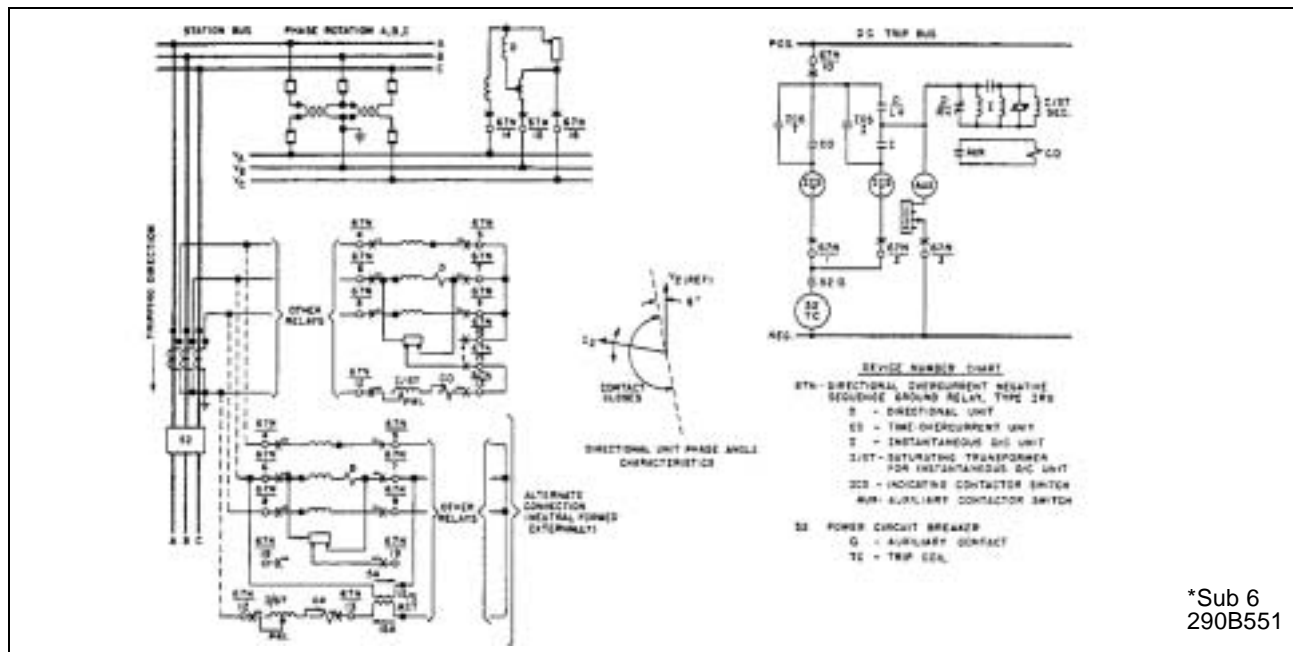

Figure 1-1 External Schematic of IRQ Relay

## 6.0 ADJUSTMENT AND MAINTENANCE

The proper adjustments to insure correct operation of this relay have been made at the factory. Upon receipt of the relay, no customer adjustments, other than those covered under "SETTINGS", should be required.

### 6.1. Acceptance Check

The following check is recommended to insure that the relay is in proper working order.

### 6.2. Negative Sequence Filter

The filters are adjusted for balance in the factory and no further adjustments or maintenance should be required. The nominal voltage and current output of the filters on positive sequence is approximately zero. This serves as a convenient check on the balance of the filters. If any two input leads to the potential filter should be interchanged, a high voltage occurs across the output terminals of the filter. Similarly, if any two of the phase leads to the input terminals of the current filter are interchanged, an output current will be obtained.

### 6.3. Directional Unit (D)

#### 6.3.1. Contact Gap

The gap between the stationary contact and moving contact with the relay in the de-energized position; should be approximately .020".

#### 6.3.2. Sensitivity

Refer to the test diagram in Figure 12.

- Apply a single-phase voltage  $V_{AB}$  equal to 0.57 volts (corresponds to a negative sequence input voltage of .19 volts) and a single-phase current equal to 6.93 amperes as shown (corresponds to a negative sequence input current of 4 amperes). With a phase angle meter connected as shown, rotate the phase shifter until the current leads the voltage by  $188^\circ$ . This corresponds to the negative sequence component of voltage by  $98^\circ$ . The directional unit contact should pick up within  $\pm 10\%$  of the above voltage to the relay.
- Next, apply 0.70 volts to terminals 15 (polarity) and 16 with 14 connected to 16. Short terminals 9 and 5 and apply 6.93 amp current in 8 and out 4. Relay must operate.

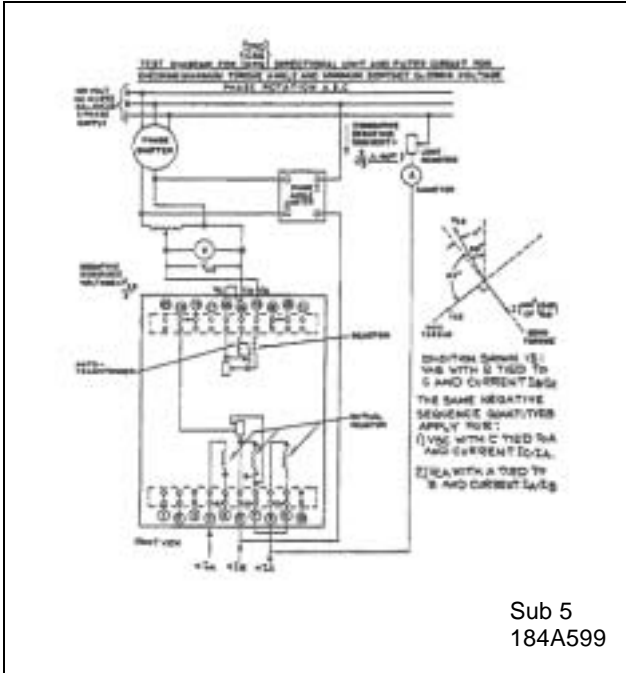

Figure 1 2 .Test Diagram for Checking Maximum Torque Angle and Minimum Voltage for Contact Closure of the Directional Unit.

- c. Repeat test (b) with 14 connected to 15, 5 connected to 7 and polarity on 16, 0.70 volts to terminals 16 and 14, and 6.93 amp current in 4 and out 6.

For relay with fault detector. Test as per (a) to (c) except apply .75 for test (a) and 0.90 volts for test (b) and (c).

The above quantities are determined as follows:

$$V_{A2} = \text{Neg. Sequence Voltage}$$

$$V_{A2} = \frac{1}{3}(V_{AN} + a^2 V_{BN} + a V_{CN})$$

$$V_{A2} = \frac{1}{3}\left(\frac{2}{3} V_{AB} - \frac{1}{3} a^2 V_{AB} - \frac{1}{3} a V_{AB}\right)$$

$$V_{A2} = \frac{V_{AB}}{3}\left(\frac{2}{3} - \frac{1}{3} a^2 - \frac{1}{3} a\right)$$

$$V_{A2} = \frac{V_{AB}}{3}$$

for  $V_{AB} = 0.57$  volts,  $V_{A2} = 0.19$  volts

$$I_{A2} = \frac{1}{3}(I_A + a^2 I_B + a I_C)$$

$$I_{A2} = \frac{1}{3}(0 + a^2 I - a I)$$

$$I_{A2} = \frac{I}{\sqrt{3}} \angle -90^\circ$$

for  $I = 6.93$  amps  $I_{A2} = 4 \angle -90^\circ$  amps

**6.3.3. Spurious Torque**

With the relay connected in the test diagram as above, remove the input voltage and connect terminals 14, 15, and 16 together. Remove the phase angle meter. With 80 amperes single-phase current applied, there should be no spurious closing torque.

**6.3.4. Apply 120 volts balance 3φ voltage, 60 Hz to terminals 14, 15 and 16 of the relay.**

Do not apply current. No trip should be observed for this condition. Reverse the voltage to terminals 14 and 15: No trip should be observed.

**6.3.5. Refer to Figure 8.**

Do not apply voltage. Pass 5 amps in terminal 6 and out terminal 8. There should be no trip. Reverse the current: no trip.

**6.4. Time Overcurrent Unit (CO)**

**6.4.1. Contacts**

The index mark on the movement frame will coincide with the "0" mark on the time dial when the stationary contact has moved through approximately one-half of its normal deflection. Therefore, with the stationary contact resting against the backstop, the index mark is offset to the right of the "0" mark approximately .020". The placement of the various time dial positions in line with the index mark will give operating times as shown on the respective time-current curves.

**6.4.2. Minimum Trip Current**

Set the time dial to position 6 with the auxiliary switch (CS-1 or TR-1) contacts blocked closed, alternately apply tap value current plus 3% and tap value current minus 3%. The moving contact should leave the backstop at tap value current plus 3% and should return to the backstop at tap value current minus 3%.

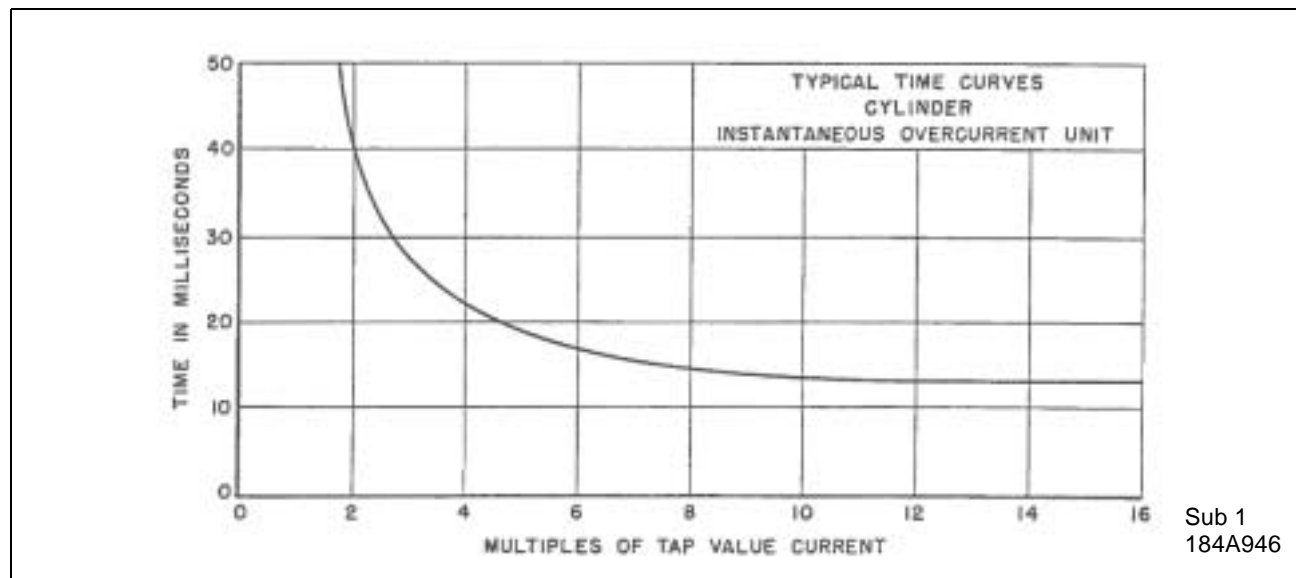

Figure 13. Typical Time Curve of the Instantaneous Overcurrent Unit

### 6.4.3. Time Curve

Table 1 shows the time curve calibration points for the various types of relays. With the time dial set to the indicated position apply the current specified by Table 1 (e.g., for the IRQ-2, 3 and 20 times tap value current), and measure the operating time of the relay. The operating times should equal those of Table 1 plus or minus 5 percent.

For Type IRQ-11 relay only, the 1.30 times tap value operating time from the number 6 time dial position is  $54.9 \pm 5\%$  seconds. It is important that the 1.30 times tap value current be maintained accurately. The maintaining of this current accurately is necessary because of the steepness of the slope of the time-curve characteristics (Fig. 21). A 1% variation in the 1.30 times tap value current (including measuring instrument deviation) will change the nominal operating time by approximately 4%.

### 6.5. Instantaneous Overcurrent Unit (I)

#### 6.5.1. Contact Gap

The gap between the stationary and moving contacts with the relay in the de-energized position should be approximately .020".

#### 6.5.2. Minimum Trip Current

The normally closed contact of the directional unit should be blocked open when checking the pickup of the overcurrent unit.

The pickup of the overcurrent unit can be checked by inserting the tap screw in the desired tap hole and applying rated tap value current. The contact should close within  $\pm 5\%$  of the tap value current.

### 6.6. Indicating Contactor Switches (ICS/I and ICS/T)

- a. Close the contacts of the CO and pass sufficient dc current through the trip circuit to close the contacts of (ICS/T). This value of current should not be greater than the particular (ICS/T) tap setting being used. The operation indicator target should drop freely, bringing the letter "T" into view.
- b. Close the contacts of the instantaneous overcurrent (I) and the directional (D) units. Pass sufficient dc current through the trip circuit to close the contacts of (ICS/I). This value of current should not be greater than the particular (ICS/I) tap setting being used. The operation indicator target should drop freely, bringing the letter "I" into view
- c. The contact gap should be approximately .047" between the bridging moving contact and the adjustable stationary contacts. The bridging moving contact should touch both stationary contacts simultaneously.

### 6.7. Routine Maintenance

All relays should be inspected periodically and the

time of operation should be checked at least once every year or at such other time intervals as may be dictated by experience to be suitable to the particular application.

If an additional time check is desired, pass secondary current through the relay and check the time of operation. It is preferable to make this at several times pick-up current at an expected operating point for the particular application. For the 0.5 to 2.5 ampere range IRQ-5 and IRQ-6 induction unit use the alternative test circuit in Figure 7 as these relays are affected by a distorted wave form. With this connection the 25/5 ampere current transformers should be worked well below the knee of the saturation (i.e., use 10L50 or better).

All contacts should be periodically cleaned. A contact burnisher #182A836H01 is recommended for this purpose. The use of abrasive material for cleaning contacts is not recommended, because of the danger of embedding small particles in the face of the soft silver and thus impairing the contact.

### 6.8. Calibration

Use the following procedure for calibrating the relay if the relay has been taken apart for repairs or the adjustments have been disturbed. This procedure should not be used unless it is apparent that the relay is not in proper working order. (See "Acceptance Check").

### 6.9. Negative Sequence Voltage Filter

- Apply 120 volts balanced 3 phase voltage 60 Hertz to terminals 14, 15, and 16 of the relay, making sure that phase A, B, and C of the applied voltage is connected to terminals 14, 15, and 16 respectively.
- Using a calibrated high resistance voltmeter, measure the voltage between the tap on the auto-transformer (middle terminal, lower-right hand reactor, rear view of Figure 1 and the tap on the adjustable 2" resistor on the upper right hand corner of Figure 2. If the voltage is high (40 to 50 volts) the filter is probably improperly connected, the voltage will be low. Using a low range (approximately 5 volts) move the adjustable tap until the voltage reads a minimum. This value should be less than 1.5 volts.

### 6.10. Negative Sequence Current Filter

Refer to Fig. 8 for positive sequence calibration.

- Connect relay terminals 7 and 9 together. Remove lead to lower right hand terminal of mutual reactor (right side view) to disconnect the direction unit.
- Pass 10 amperes in terminal 6 and out terminal 8.
- With a 0-15 volts, high resistance voltmeter, measure and record voltage between terminals 6 and the lower right hand terminal of mutual reactor. This voltage should be between 1.85 and 1.95 volts.
- Now measure the voltage from terminal 6 to terminal 7. Adjust the top filter resistor tap until this voltage is 1.73 times the reading of part C.

Refer to Fig. 8 for neutral tap calibration

Using the test connections as shown and a low range voltmeter connected between terminal 6 and 7, adjust the middle filter resistor tap connection until the measured voltage is zero. Reconnect lead to mutual reactor at end of this test.

### 6.11. Directional Unit (D)

- The upper bearing screw should be screwed down until there is approximately .025" clearance between it and the top of the shaft bearing. The upper pin bearing should then be securely locked in position with the lock nut.
- Contact gap adjustment for the directional unit is made with the moving contact in the reset position, i.e., against the right side of the bridge. Advance the right hand stationary contact until the contacts just close. Then advance the stationary contact and additional one-half turn.

Now move in the left hand stationary contact until it just touches the moving contact. Then back off the stationary contact 3/4 of one turn for a contact gap of .020" to .024". The clamp holding the stationary contact housing need not be loosened for the adjustment since the clamp utilizes a spring-type action in holding the stationary contact in position.

- The sensitivity adjustment is made by varying the tension of the spiral spring attached to the moving element assembly. The spring is

adjusted by placing a screwdriver or similar tool into one of the notches located on the periphery of the spring adjuster and rotating it. The spring adjuster is located on the underside of the bridge and is held in place by a spring type clamp that does not have to be loosened prior to making the necessary adjustments.

The spring is to be adjusted such that the contacts will close when the relay is energized 0.57 volts and 6.93 amps at 188° (current leading voltage), considering the relay connected to the test circuit in Figure 12.

- d. The magnetic plugs are used to reverse any unwanted spurious torques that may be present when the relay is energized on current alone.

The reversing of the spurious torques is accomplished by using the adjusting plugs in the following manner:

- 1) Connect the relay voltage circuit terminals (phase A, B, and C) together.
- 2) Apply 80 amperes single-phase current (momentarily) in phase B terminal and out phase C terminal.

Plug adjustment is then made per Table 2 such that any contact closing spurious torques are reversed. The plugs are held in position by upper and lower plug clips. These clips need not be disturbed in any manner when making the necessary adjustment.

The magnetic plug adjustment may be utilized to positively close the contacts on current alone. This may be desired on some installations in order to insure that the relay will always trip the breaker on zero potential.

- e. The core adjustment is made as follows:

Relay must not trip with 120 V $\phi$ - $\phi$  Positive Sequence voltage only applied to terminals 14, 15, and 16 must not trip when terminals 14 and 15 are reversed.

If trip is observed for either condition, proceed as follows:

With balance 120V, 3 phase 60 Hz voltage applied to terminals 14, 15 and 16 adjust core until the contact arm just restrains. The core can be adjusted by the use of an insulated screwdriver in the slots at the bottom of the cylinder

unit. Recheck on balanced, 3 phase, 120V positive sequence voltage. Relay must not operate.

#### 6.12. Instantaneous Overcurrent Unit (1)

- a. The upper pin bearing should be screwed down until there is approximately .025" clearance between it and the top of shaft bearing. The upper pin bearing should then be securely locked in position with the lock nut. The lower bearing position is fixed and cannot be adjusted.
- b. The contact gap adjustment for the overcurrent unit is made with the moving contact in the reset position, i.e., against the right side of the bridge. Move in the left hand stationary contact until it just touches the moving contact then back off the stationary contact 2/3 of one turn for a gap of approximately .020". The clamp holding the stationary contact housing need not be loosened for the adjustment since the clamp utilizes a spring-type action in holding the stationary contact in position.
- c. The sensitivity adjustment is made by varying the tension of the spiral spring attached to the moving element assembly. The spring is adjusted by placing a screwdriver or similar tool into one of the notches located on the periphery of the spring adjuster and rotating it. The spring adjuster is located on the underside of the bridge and is held in place by a spring-type clamp that does not have to be loosened prior to making the necessary adjustments.

Before applying current, block open the normally-closed contact of the directional unit. Insert the tap screw in the minimum value tap setting and adjust the spring such that the contacts will close as indicated by a neon lamp in the contact circuit when energized with the required current. The pick up of the overcurrent unit with the tap screw in any other tap should be within  $\pm 5\%$  of tap value.

If adjustment of pickup current in between tap settings is desired, insert the tap screw in the next lowest tap setting and adjust the spring as described. It should be noted that this adjustment results in a slightly different time characteristic curve and burden.

### 6.13. Time Overcurrent Unit (CO)

#### 6.13.1. Contacts

The index mark on the movement frame will coincide with the "0" mark on the time dial when the stationary contact has moved through approximately one-half of its normal deflection. Therefore, with the stationary contact resting against the backstop, the index mark is offset to the right of the "0" mark by approximately .020". The placement of the various time dial positions in line with the index mark will give operating times as shown on the respective time-current curves.

#### 6.13.2. Minimum Trip Current

The adjustment of the spring tension in setting the minimum trip current value of the relay is most conveniently made with the damping magnet removed.

With the time dial set on "0" wind up the spiral spring by means of the spring adjusted until approximately 6 3/4 convolutions show.

Set the relay on the minimum tap setting, the time dial to position 6.

With the auxiliary switch (CS-1 or TR-1) contacts blocked closed, adjust the control spring tension so that the moving contact will leave the backstop at tap value current +1.0% and will return to the backstop at tap value current -1.0%.

#### 6.13.3. Time Curve Calibration – Install the permanent magnet

Apply the indicated current per Table 1 for permanent magnet adjustment (e.g., IRQ-8, 2 times tap value) and measure the operating time. Adjust the permanent magnet keeper until the operating time corresponds to the value of Table 1.

For Type IRQ-11 relay only, the 1.30 times tap value operating time from the number 6 time dial position is  $54.9 \pm 5\%$  seconds. It is important that the 1.30 times tap value current be maintained accurately. The maintaining of this current accurately is necessary because of the steepness of the slope of the time-current characteristics (Fig. 21). A 1% variation in the 1.30 times tap value current (including measurement deviation) will change the nominal operating time by approximately 4% if the operating time at 1.3 times tap value is not within these limits, a minor adjustment of the control spring will give the correct operating time without any undue effect on the minimum

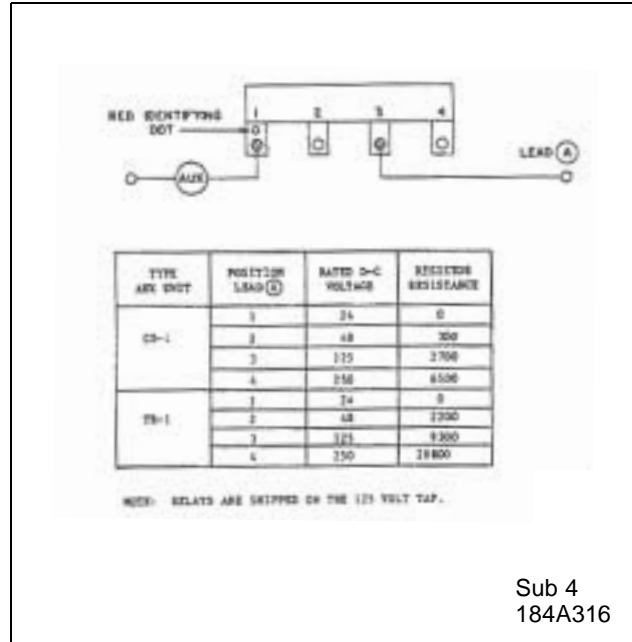

Sub 4  
184A316

Figure 14. Selection of Proper Voltage Tap for Auxiliary Switch (CS-1) Operation

pick-up of the relay. This check is to be made after the 2 times tap value adjustment has been completed.

Apply the indicated current per Table 1 for the electromagnet plug adjustment (e.g., IRQ-8, 20 times tap value) and measure the operating time. Adjust the proper plug until the operating time corresponds to the value in Table 1 (Withdrawing the left hand plug, front view increases the operating time and withdrawing the right hand plug, front view, decreases the time.) In adjusting the plugs, one plug should be screwed in completely and the other plug run in or out until the proper operating time has been obtained.

Recheck the permanent magnet adjustment. If the operating time for this calibration test point has changed, readjust the permanent magnet and then recheck the electromagnet plug adjustment.

#### 6.14. Indicating Contactor Switches (ICS/I) and (ICS/T)

- Close the contacts of the CO and the directional unit and pass sufficient dc current through the trip circuit to close the contacts of the (ICS/T). This value of current should not be greater than the particular (ICS/T0 tap setting being used. The operation indicator target should drop freely

bringing the letter "T" into view.

- b. Close the contacts of the CO and the directional unit and pass sufficient dc current through the trip circuit to close the contacts of the (ICS/T). This value of current should not be greater than the particular (ICS/T) tap setting being used. The operation indicator target should drop freely bringing the letter "T" into view.
- c. Close contacts of instantaneous overcurrent unit (I) and directional unit (D). Pass sufficient dc current through the trip circuit to close contacts of the (ICS/I). This value of current should not be greater than the particular (ICS/I) tap setting being used. The operation indicator target should drop freely bringing the letter "I" into view.

**6.15. Auxiliary Switch (CS-1 or TR-1)**

Adjust the stationary core of the CS-1 switch for a clearance between the stationary core and the moving core when the switch is picked up. This can be done by turning the relay upside-down. Then screw the core screw up until the moving core starts rotating. Now back off the core screw until the moving core stops rotating. This indicates the points when

the play in the assembly is taken up, and where the moving core just separates from the stationary core screw. Back off the core screw approximately one turn and lock in place. This prevents the moving core from striking and sticking to the stationary core because of residual magnetism. Adjust the contact clearance for 3/64" by means of the two small nut(s) on either side of the Micarta disc.

The TR-1 unit does not require adjustments.

Connect lead (A) to proper terminal per Figure 14. Block directional unit (D) contacts close and energize trip circuit with rated voltage. Contacts of auxiliary switch (CS-1 or TR-1) should make as indicated by a neon lamp in the contact circuit.

**7.0 RENEWAL PARTS**

Repair work can be done most satisfactorily at the factory. However, interchangeable parts can be furnished to the customers who are equipped for doing repair work. When ordering parts, always give the complete nameplate data.

**Table 1:  
TIME CURVE CALIBRATION DATA - 60 HERTZ**

TIME OVERCURRENT UNIT TYPE	PERMANENT MAGNET ADJUSTMENT			ELECTROMAGNET PLUGS	
	TIME DIAL POSITION	CURRENT (MULTIPLES OF TAP VALUE)	OPERATING TIME SECONDS	CURRENT (MULTIPLES OF TAP VALUE)	OPERATING TIME SECONDS
IRQ-2	6	3	0.57	20	0.22
IRQ-5	6	2	37.80	10	14.30
IRQ-6	6	2	2.46	20	1.19
IRQ-7	6	2	4.27	20	1.11
IRQ-8	6	2	13.35	20	1.11
IRQ-9	6	2	8.87	20	0.65
IRQ-11	6	2	11.27	20	0.24

**Table II:  
DIRECTIONAL UNIT CALIBRATION‡**

RELAYING RATING	CURRENT AMPERES	BOTH PUGS IN CONDITION	ADJUSTMENT
All Ranges	80	Spurious Torque in Contact Closing Direction (Left Front View)	Right (Front View) Plug Screwed Out Until Spurious Torque is Reversed.
All Ranges	80	Spurious Torque in Contact Opening Direction (Right Front View) (Contacts remain open)	Left (Front-View) Plug Screwed Out Until Spurious Torque is in Contact Closing Direction. Then the Plug is Screwed in Until Spurious Torque is Reversed.

‡ Short circuit the voltage polarizing circuit at the relay terminals before making the above adjustment.

**ENERGY REQUIREMENTS  
IRQ-2 TIME OVERCURRENT UNITS**

AMPERE RANGE	TAP	CONTINUOUS RATING (AMPERES)	ONE SECOND RATING * (AMPERES)	POWER FACTOR ANGLE Ø	VOLT AMPERES **			
					AT TAP VALUE CURRENT	AT 3 TIMES TAP VALUE CURRENT	AT 10 TIMES TAP VALUE CURRENT	AT 20 TIMES TAP VALUE CURRENT
0.5/2.5	0.5	0.91	28	58	4.8	39.6	256	790
	0.6	0.96	28	57	4.9	39.8	270	851
	0.8	1.18	28	53	5.0	42.7	308	1024
	1.0	1.37	28	50	5.3	45.4	348	1220
	1.5	1.95	28	40	6.2	54.4	435	1740
	2.0	2.24	28	36	7.2	65.4	580	2280
	2.5	2.50	28	29	7.9	73.6	700	2850
2/6	2.0	3.1	110	59	5.04	38.7	262	800
	2.5	4.0	110	55	5.13	39.8	280	920
	3.0	4.4	110	51	5.37	42.8	312	1008
	3.5	4.8	110	47	5.53	44.2	329	1129
	4.0	5.2	110	45	5.72	46.0	360	1216
	5.0	5.6	110	41	5.90	50.3	420	1500
	6.0	6.0	110	37	6.54	54.9	474	1800
4/12	4.0	7.3	230	65	4.92	39.1	268	848
	5.0	8.0	230	50	5.20	42.0	305	1020
	6.0	8.8	230	47	5.34	44.1	330	1128
	7.0	9.6	230	46	5.53	45.8	364	1260
	8.0	10.4	230	43	5.86	49.9	400	1408
	10.0	11.2	230	37	6.6	55.5	470	1720
	12.0	12.0	230	34	7.00	62.3	528	2064

\* Thermal capacities for short times other than one second may be calculate on the basis of time being inversely proportional to the square of the current.

Ø Degrees current lags voltage at tap value current.

\*\* Voltages taken with Rectox type voltmeter.



**ENERGY REQUIREMENTS**  
IRQ-5, IRQ-6, TIME OVERCURRENT UNITS

AMPERE RANGE	TAP	CONTINUOUS RATING (AMPERES)	ONE SECOND RATING * (AMPERES)	POWER FACTOR ANGLE Ø	VOLT AMPERES **			
					AT TAP VALUE CURRENT	AT 3 TIMES TAP VALUE CURRENT	AT 10 TIMES TAP VALUE CURRENT	AT 20 TIMES TAP VALUE CURRENT
0.5/2.5	0.5	2.7	88	69	3.92	20.6	103	270
	0.6	3.1	88	68	3.96	20.7	106	288
	0.8	3.7	88	67	3.96	21	114	325
	1.0	4.1	88	66	4.07	21.4	122	360
	1.5	5.7	88	62	4.19	23.2	147	462
	2.0	6.8	88	60	4.30	24.9	168	548
	2.5	7.7	88	58	4.37	26.2	180	630
2/6	2	8	230	67	3.88	21	110	308
	2.5	8.8	230	66	3.90	21.6	118	342
	3	9.7	230	64	3.93	22.1	126	381
	3.5	10.4	230	63	4.09	23.1	136	417
	4	11.2	230	62	4.12	23.5	144	448
	5	12.5	230	59	4.20	24.8	162	540
	6	13.7	230	57	4.38	26.5	183	624
4/12	4	16	460	65	4.00	22.4	126	376
	5	18.8	460	63	4.15	23.7	143	450
	6	19.3	460	61	4.32	25.3	162	531
	7	20.8	460	59	4.35	26.4	183	611
	8	22.5	460	56	4.40	27.8	204	699
	10	25	460	53	4.60	30.1	247	880
	12	28	460	47	4.92	35.6	288	1056

**ENERGY REQUIREMENTS**  
IRQ-7, TIME OVERCURRENT UNITS

AMPERE RANGE	TAP	CONTINUOUS RATING (AMPERES)	ONE SECOND RATING * (AMPERES)	POWER FACTOR ANGLE Ø	VOLT AMPERES **			
					AT TAP VALUE CURRENT	AT 3 TIMES TAP 19 CURRENT	AT 10 TIMES TAP VALUE CURRENT	AT 20 TIMES TAP VALUE CURRENT
0.5/2.5	0.5	2.7	88	68	3.88	207	103	278
	0.6	3.1	88	67	3.93	20.9	107	288
	0.8	3.7	88	66	3.93	21.1	114	320
	1.0	4.1	88	64	4.00	21.6	122	356
	1.5	5.7	88	61	4.08	22.9	148	459
	2.0	6.8	88	58	4.24	24.8	174	552
	2.5	7.7	88	56	4.38	25.9	185	640
2/6	2	8	230	66	4.06	21.3	111	306
	2.5	8.8	230	63	4.07	21.8	120	342
	3	9.7	230	63	4.14	22.5	129	366
	3.5	10.4	230	62	4.34	23.4	141	413
	4	11.2	230	61	4.34	23.8	149	448
	5	12.5	230	59	4.40	25.2	163	530
	6	13.7	230	58	4.62	27	183	624
4/12	4	16	460	64	4.24	22.8	129	392
	5	18.8	460	61	4.30	24.2	149	460
	6	19.3	460	60	4.62	25.9	168	540
	7	20.8	460	58	4.69	27.3	187	626
	8	22.5	460	55	4.80	29.8	211	688
	10	25	460	51	5.20	33	260	860
	12	28	460	46	5.40	37.5	308	10328

\* Thermal capacities for short times other than one second may be calculate on the basis of time being inversely proportional to the square of the current.

Ø Degrees current lags voltage at tap value current.

\*\* Voltages taken with Rectox type voltmeter.

**ENERGY REQUIREMENTS  
IRQ-8, IRQ-9, TIME OVERCURRENT UNITS**

AMPERE RANGE	TAP	CONTINUOUS RATING (AMPERES)	ONE SECOND RATING * (AMPERES)	POWER FACTOR ANGLE Ø	VOLT AMPERES **			
					AT TAP VALUE CURRENT	AT 3 TIMES TAP VALUE CURRENT	AT 10 TIMES TAP VALUE CURRENT	AT 20 TIMES TAP VALUE CURRENT
0.5/2.5	0.5	2.7	88	72	2.38	21	132	350
	0.6	3.1	88	71	2.38	21	134	365
	0.8	3.7	88	69	2.40	21.1	142	400
	1.0	4.1	88	67	2.42	21.2	150	440
	1.5	5.7	88	62	2.51	22	170	530
	2.0	6.8	88	57	2.65	23.5	200	675
	2.5	7.7	88	53	2.74	24.8	228	800
2/6	2	8	230	70	2.38	21	136	360
	2.5	8.8	230	66	2.40	21.1	142	395
	3	9.7	230	64	2.42	21.5	149	430
	3.5	10.4	230	62	2.48	22	157	470
	4	11.2	230	60	2.53	22.7	164	500
	5	12.5	230	58	2.64	24	180	580
	6	13.7	230	56	2.75	25.2	198	660
4/12	4	16	460	68	2.38	21.3	146	420
	5	18.8	460	63	2.46	21.8	158	480
	6	19.3	460	60	2.54	22.6	172	550
	7	20.8	460	57	2.62	23.6	190	620
	8	22.5	460	54	2.73	24.8	207	700
	10	25	460	48	3.00	27.8	248	850
	12	28	460	45	3.46	31.4	292	1020

**ENERGY REQUIREMENTS  
IRQ-11, TIME OVERCURRENT UNITS**

AMPERE RANGE	TAP	CONTINUOUS RATING (AMPERES)	ONE SECOND RATING * (AMPERES)	POWER FACTOR ANGLE Ø	VOLT AMPERES **			
					AT TAP VALUE CURRENT	AT 3 TIMES TAP VALUE CURRENT	AT 10 TIMES TAP VALUE CURRENT	AT 20 TIMES TAP VALUE CURRENT
0.5/2.5	0.5	1.7	56	36	0.72	6.54	71.8	250
	0.6	1.9	56	34	0.75	6.80	75.0	267
	0.8	2.2	56	30	0.81	7.46	84.0	298
	1.0	2.5	56	27	0.89	8.30	93.1	330
	1.5	3.0	56	22	1.13	10.04	115.5	411
	2.0	3.5	56	17	1.30	11.95	136.3	502
	2.5	3.8	56	16	1.48	13.95	160.0	610
2/6	2	7.0	230	32	0.73	6.30	74.0	264
	2.5	7.8	230	30	0.78	7.00	78.5	285
	3	8.3	230	27	0.83	7.74	84.0	309
	3.5	9.0	230	24	0.88	8.20	89.0	340
	4	10.0	230	23	0.96	9.12	102.0	372
	5	11.0	230	20	1.07	9.80	109.0	430
	6	12.0	230	20	1.23	11.34	129.0	504
4/12	4	14	460	29	0.79	7.08	78.4	296
	5	16	460	25	0.89	8.00	90.0	340
	6	17	460	22	1.02	9.18	101.4	378
	7	18	460	20	1.10	10.00	110.0	454
	8	20	460	18	1.23	11.1	124.8	480
	10	22	460	17	1.32	14.9	131.6	600
	12	26	460	16	1.8	16.3	180.0	720

\* Thermal capacities for short times other than one second may be calculate on the basis of time being inversely proportional to the square of the current.

Ø Degrees current lags voltage at tap value current.

\*\* Voltages taken with Rectox type voltmeter.

**ENERGY REQUIREMENTS FOR THE  
SEQUENCE FILTER AND THE DIRECTIONAL UNIT  
(All Burdens at 60 Hertz)**

The current burden of the relay with positive sequence currents applied (no output current to the directional unit) is as follows:

Phase	Continuous Rating-Amps	One Second Rating-Amps	Watts at 5 Amps	Volt-Amp at 5 Amps	Power Factor Angle
A	10	150	5.4	7.5	44° Lag
B	10	150	5.5	5.5	0°
C	10	150	.35	1.28	74° Lag

The current burden of the relay with Zero sequence currents applied is as follows:

Phase	Watts At 5 Amps	Volt Amps At 5 Amps	Power Factor Angle
A	4.66	5.5	32°
B	4.92	5.0	10°
C	3.30	3.7	27°

The voltage burden of the relay with positive sequence voltage applied (no output voltage to the directional unit) is as follows:

Pot. Transf. Across Phase	Volts	Watts	Volt-Amps	Power Factor Angle
---------------------------	-------	-------	-----------	--------------------

Burden values on three star connected potential transformers. Values at the star Voltage of 66.4 volts (115 volts delta):

A	115	0	26.8	90° Lag
B	115	0.2	0.3	48° Lag
C	115	23.2	27.0	30° Lag

Burden values on two open-delta potential transformers. Values at 115 volts:

AB	115	-23.2	46.5	120° Lag
BC	115	46.6	46.6	0°
BC	115	10	.48	58° Lag
CA	115	23.2	46.5	60° Lag
CA	115	23.2	46.6	60° Lag
AB	115	0.50	0.5	22° Lag

Burden values on three delta connected potential transformers. Values at 115 volts:

	CA	115	15.4	31.0	60°
<b>Lag</b>	AB	115	-7.8	15.6	120° Lag
	BC	115	15.6	15.6	0°

**ENERGY REQUIREMENTS  
INSTANTANEOUS OVERCURRENT UNIT OPERATING CURRENT CIRCUIT - 60 HERTZ**

AMPERE RANGE	TAP	VA AT TAP VALUE ††	P.F. ANGLE Ø	VA AT 5 AMPS ††	P.F. ANGLE Ø
.5-2	.5	.37	39	24	46
	.75	.38	36	13	37
	1	.39	35	8.5	34
	1.25	.41	34	6.0	32
	1.5	.43	32	4.6	31
	2	.45	30	2.9	28
1-4	1	.41	36	9.0	36
	1.5	.44	32	5.0	32
	2	.47	30	3.0	29
	2.5	.50	28	2.1	27
	3	.53	26	1.5	26
2-8	4	.59	24	0.93	24
	2	1.1	49	6.5	48
	3	1.2	43	3.3	42
	4	1.3	38	2.1	37
	5	1.4	35	1.4	35
	6	1.5	33	1.1	33
4-16	8	1.8	29	0.7	29
	4	1.5	51	2.4	51
	6	1.7	45	1.2	45
	8	1.8	40	0.7	40
	9	1.9	38	0.6	38
	12	2.2	34	0.37	34
10-40	16	2.5	30	0.24	31
	10	1.7	28	0.43	28
	15	2.4	21	0.27	21
	20	3.1	16	0.20	17
	24	3.6	15	0.15	15
	30	4.2	12	0.11	13
20-80	40	4.9	11	0.08	12
	20	6.6	31	0.40	31
	30	9.3	24	0.25	24
	40	12	20	0.18	20
	48	13.5	18	0.14	18
	60	15.9	16	0.10	16
80	19.2	15	0.07	15	

RANGE	CONTINUOUS RATING (AMPERES)	ONE SECOND RATING † (AMPERES)
.5-2	5	100
1-4	8	140
2-8	8	140
4-16	10	200
10-40	10	200
20-80	10	200

\* Thermal capacities for short times other than one second may be calculate on the basis of time being inversely proportional to the square of the current.

Ø Degrees current lags voltage at tap value current.

\*\* Voltages taken with Rectox type voltmeter.

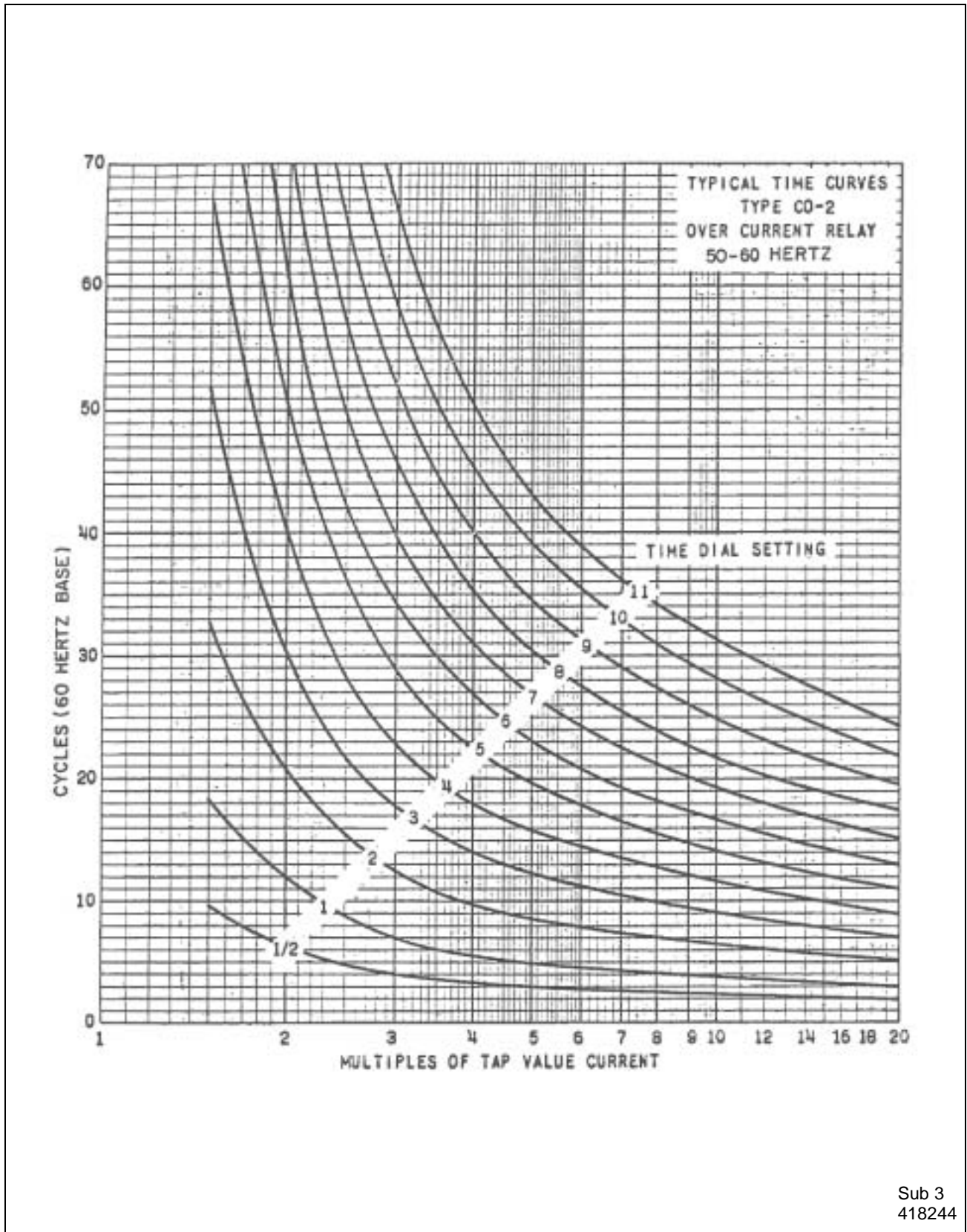

Figure 15. Typical Time Curve of the Time Overcurrent Unit of the Short Time (2) Relay

Sub 3  
418244

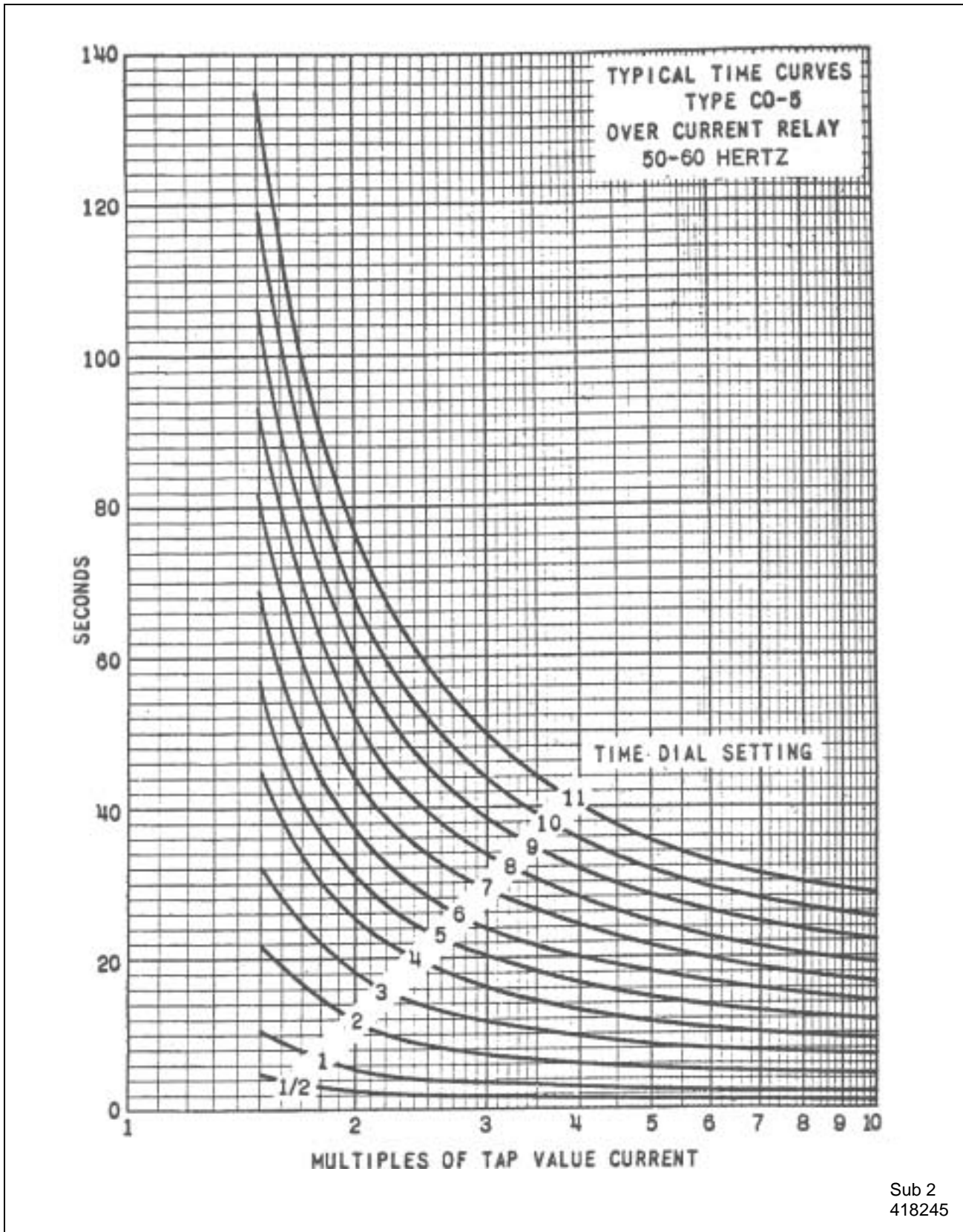

Figure 16. Typical Time Curve of the Time Overcurrent Unit of the Long Time (5) Relay

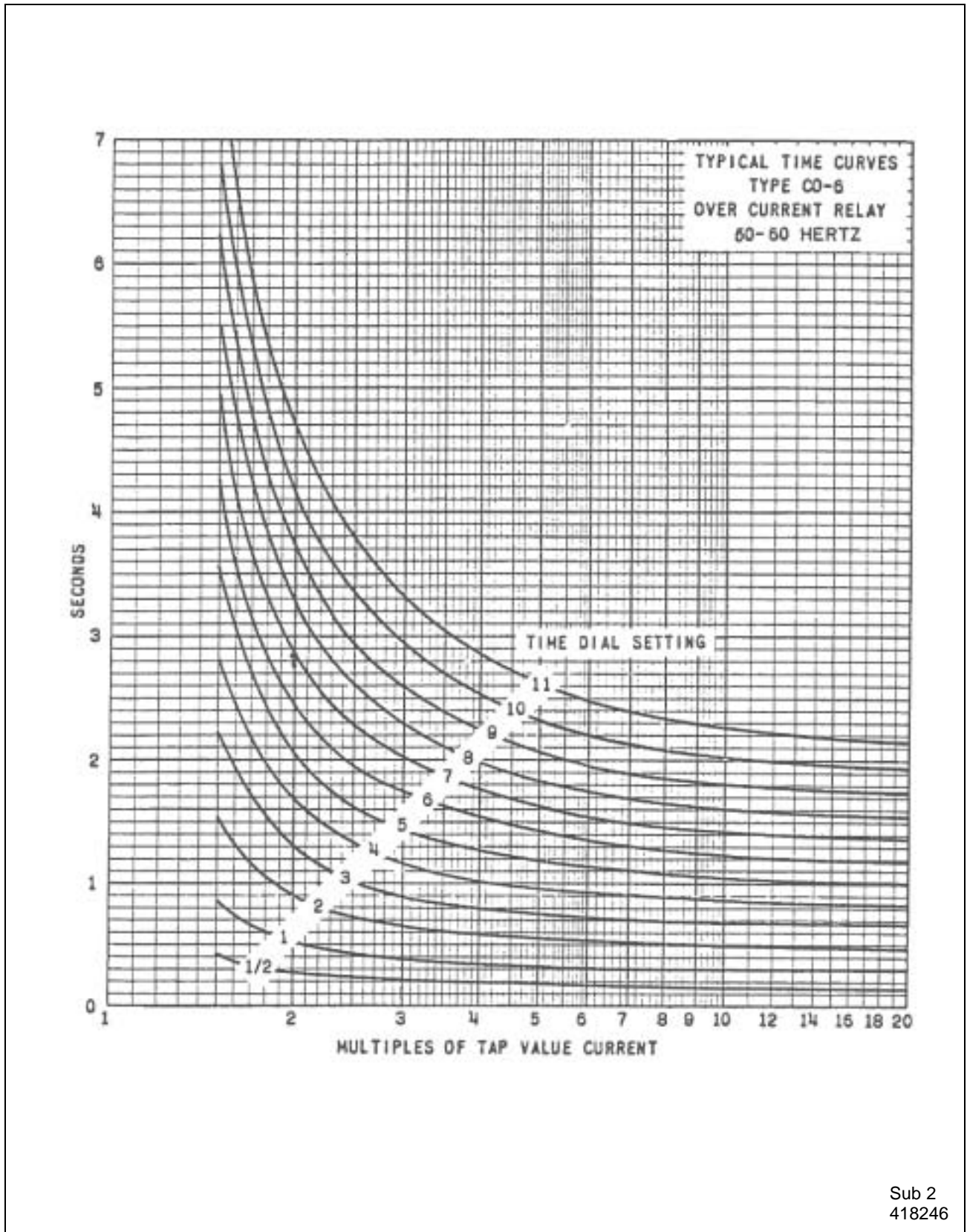
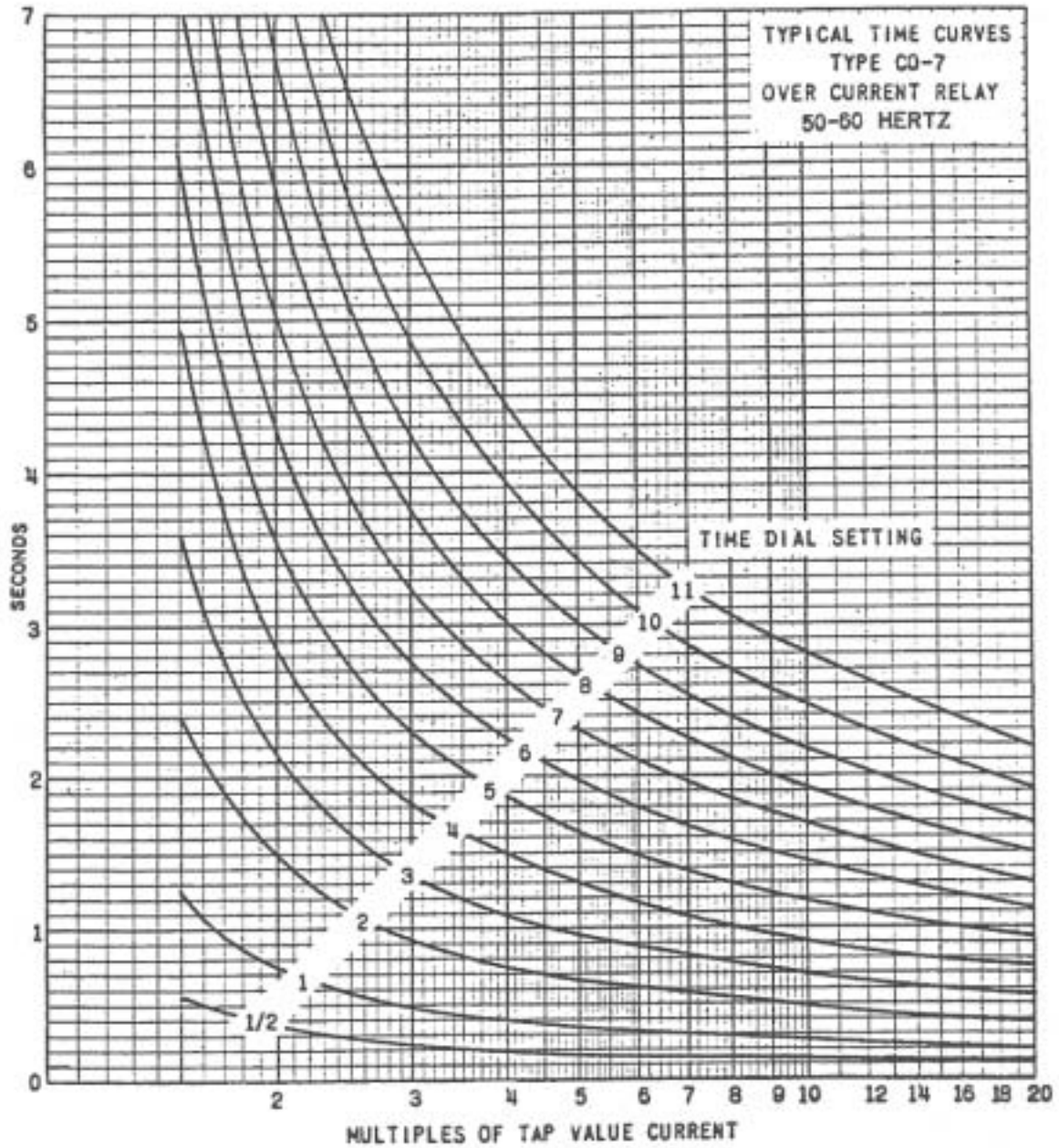

Figure 17. Typical Time Curve of the Time Overcurrent Unit of the Definite Time (6) Relay

Sub 2  
418246



Sub 2  
418247

Figure 18. Typical Time Curve of the Time Overcurrent Unit of the Moderately Inverse (7) Relay



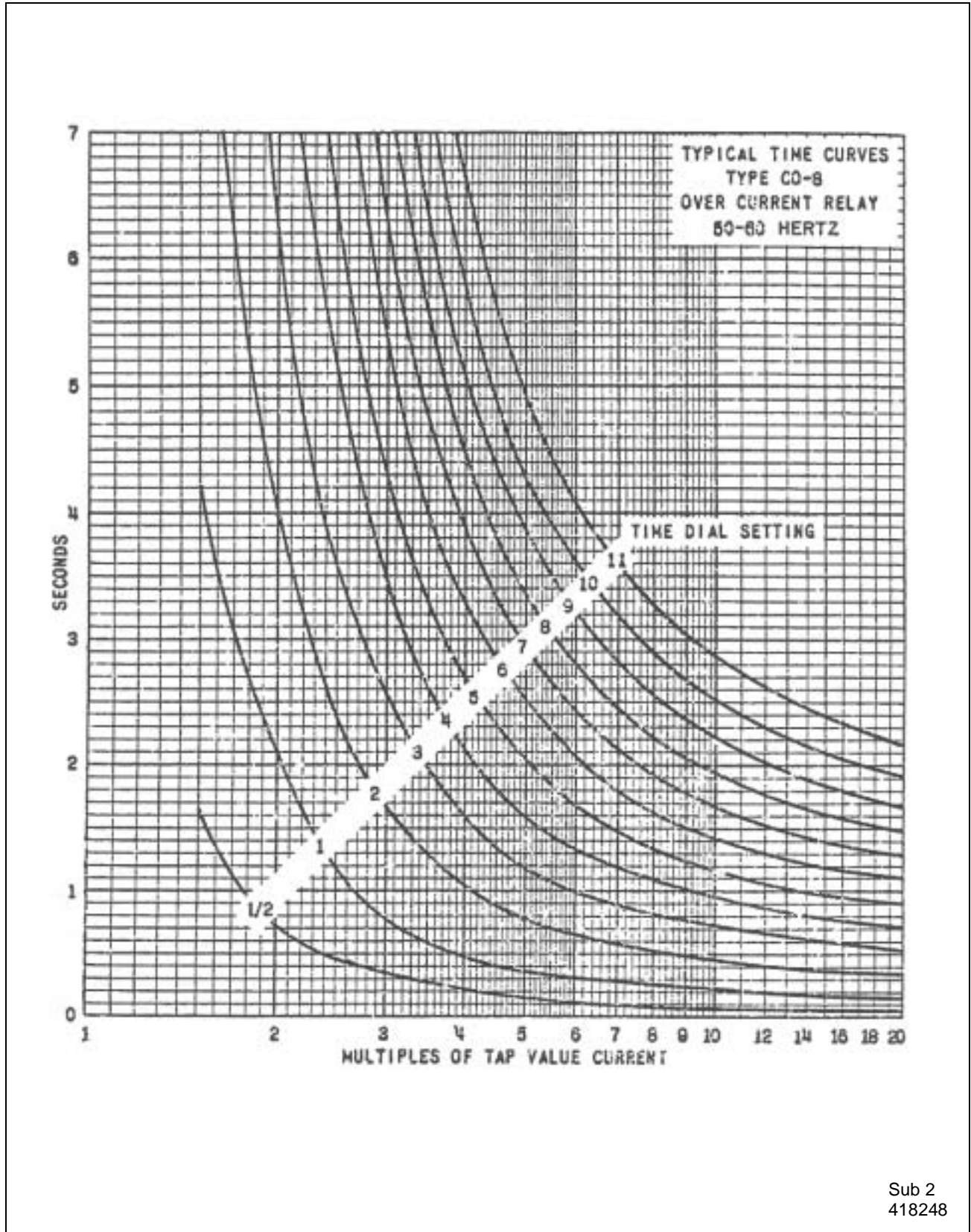
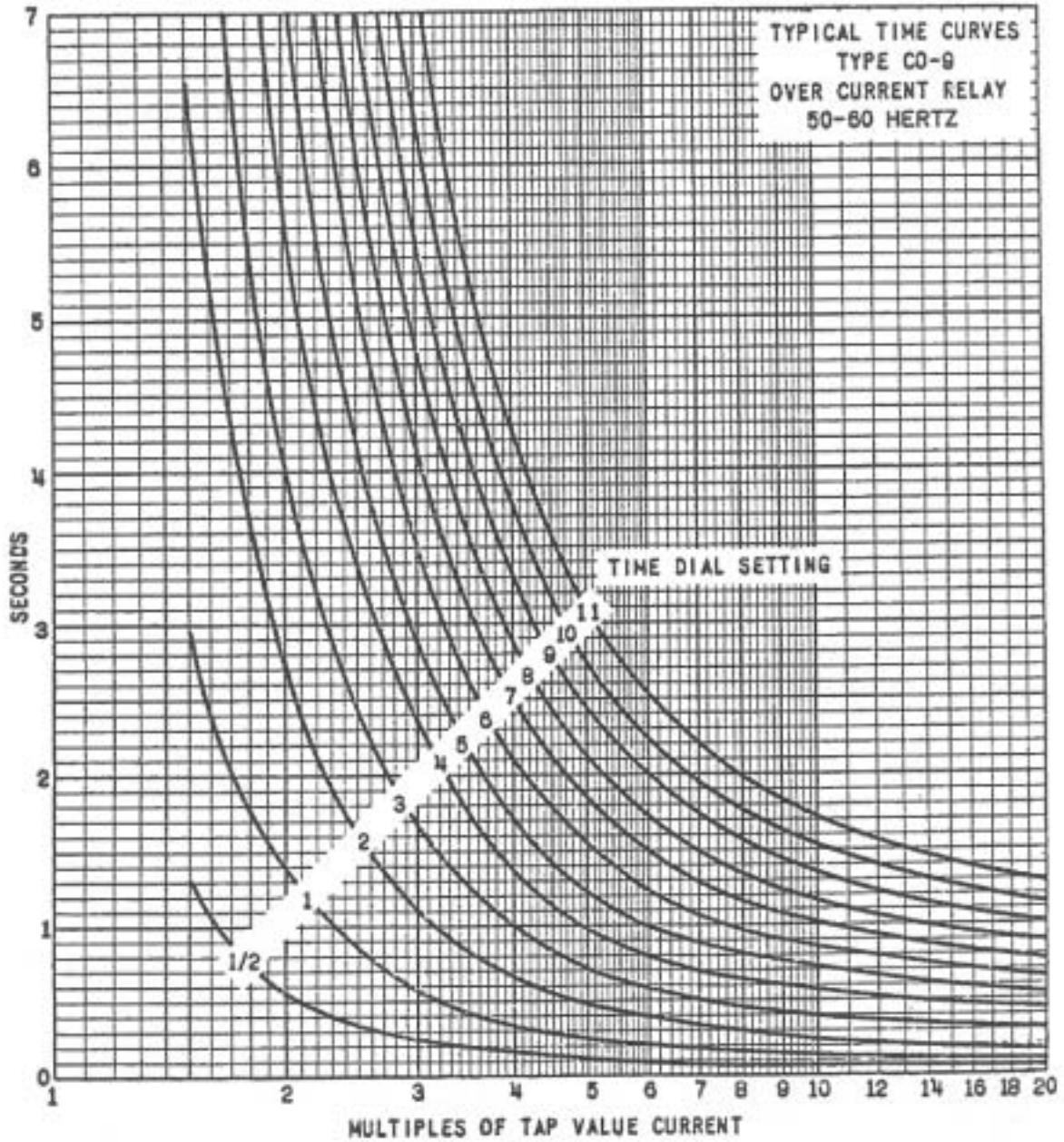
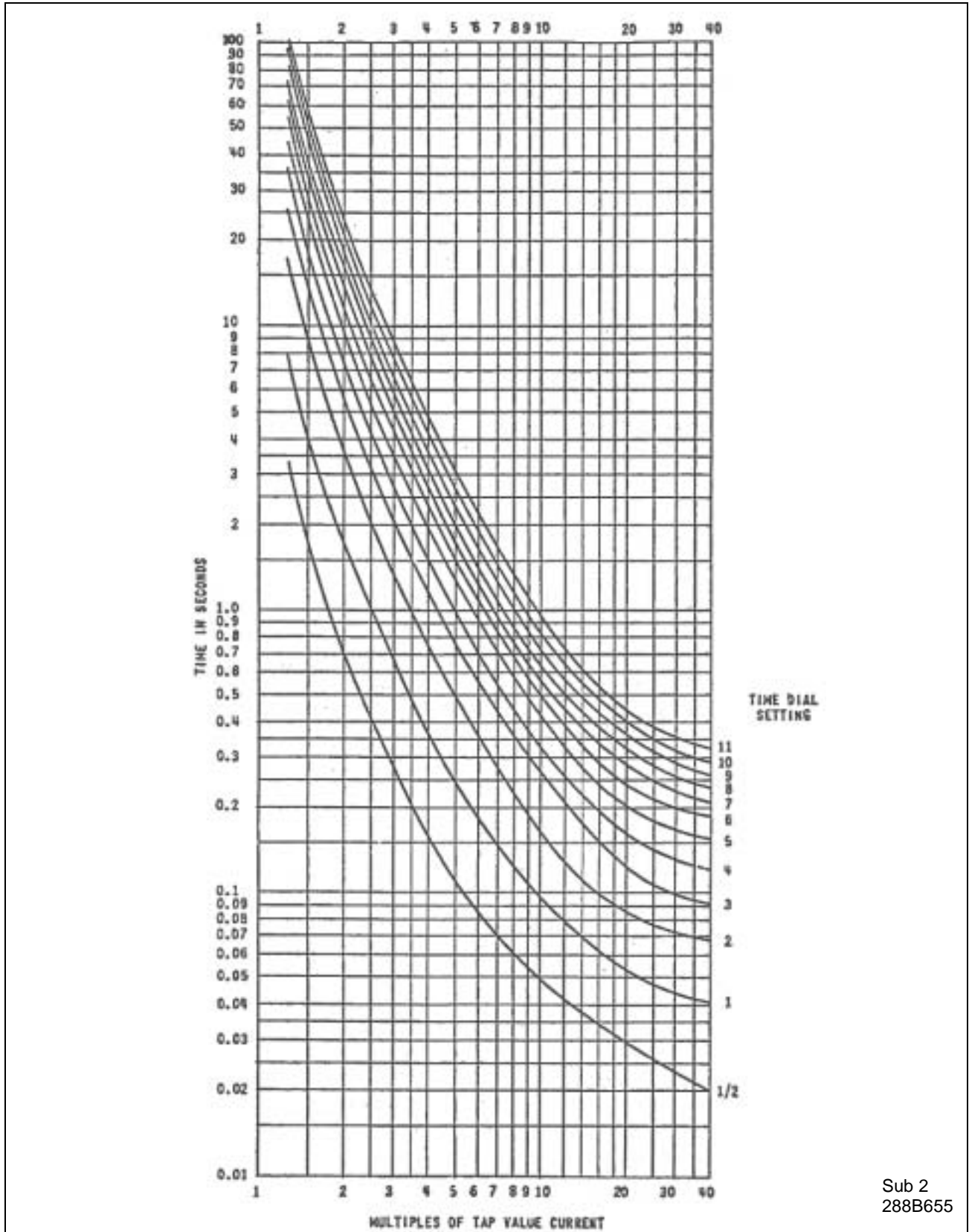

Figure 19. Typical Time Curve of the Time Overcurrent Unit of the Inverse (8) Relay



Sub 2  
418249

Figure 20. Typical Time Curve of the Time Overcurrent Unit of the Very Inverse (9) Relay



Sub 2  
288B655

Figure 21. Typical Time Curve of the Time Overcurrent Unit of the Extremely Inverse (11) Relay

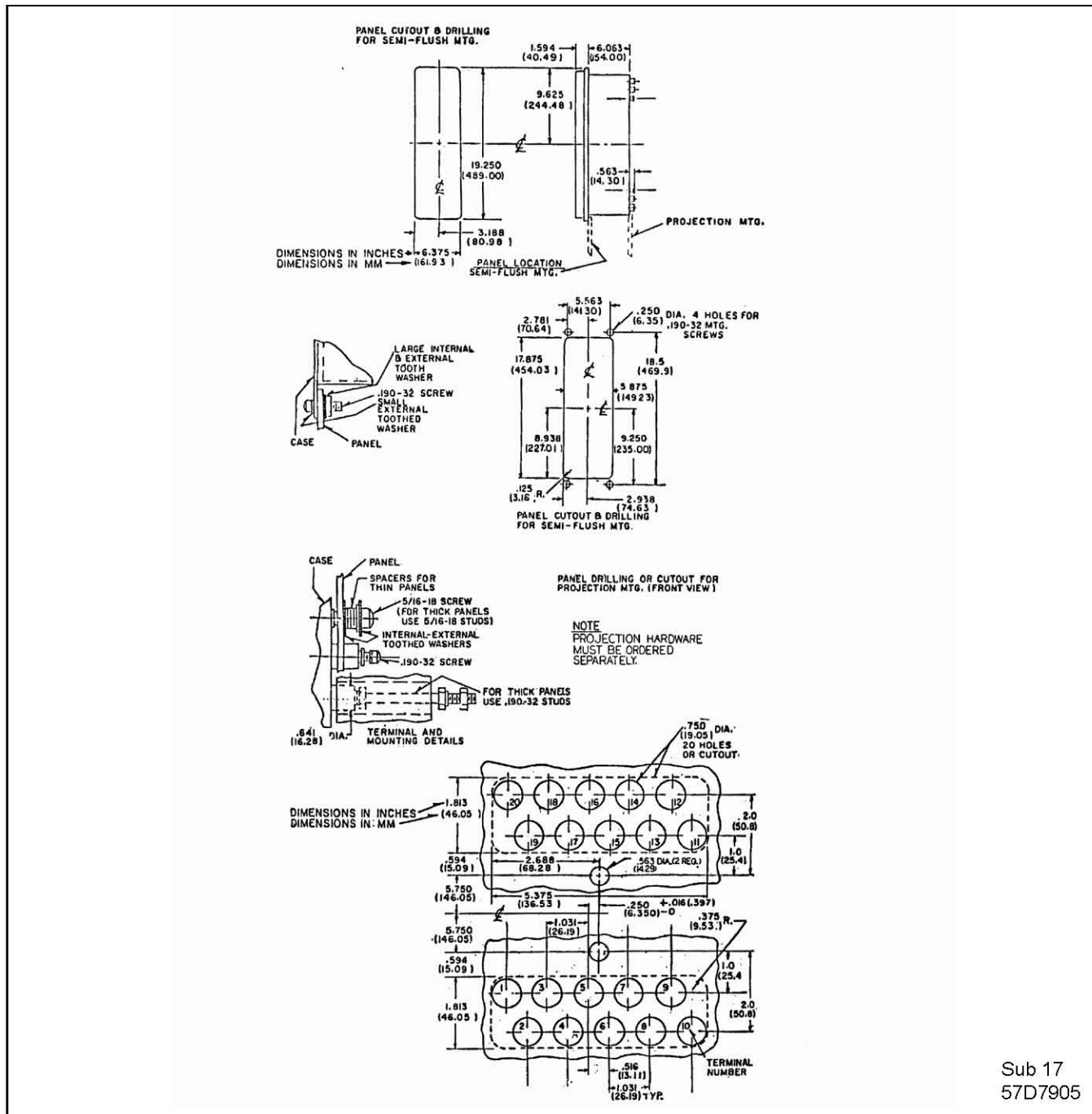

Figure 22. Outline and Drilling Plan for the Type IRQ Relay in the FT-42 Case



ABB Inc.  
4300 Coral Ridge Drive  
Coral Springs, Florida 33065  
Telephone: +1 954-752-6700  
Fax: +1 954-345-5329  
www.abb.com/substation automation