

for light and medium duty applications

■ Modular system

- Measuring inset, thermowell, extension tube, connection head, transmitter
- Supports numerous configurations

■ Exchangeable measuring inset

- Measuring elements can be exchanged during operation
- Secure base contact via pressure springs

■ Approvals

- ATEX Ex i
- ATEX Dust ignition proof
- GOST Russia
- GOST Kazakhstan
- GOST Ukraine

■ Transmitter in connection head

- Less wiring expense
- High accuracy
- High interference resistance
- Interface to all state-of-the-art process management systems
- Process safety via SIL2 classification

■ Areas of application

- Chemical industry
- Energy industry
- General process engineering
- Tank and pipeline construction
- Manufacturing systems and plant engineering
- Food and drink industry



Modular design
Versatile, easy to use
No maintenance required

Contents

1	Overview of temperature sensors with an exchangeable measuring inset	3
2	Overview of measuring insets	4
3	General information	5
3.1	Ambient temperature at connection head	5
3.2	Maximum process temperature	5
3.3	Pressure and vibration resistance of thermowell	5
3.4	Measurement range of measuring inset	7
3.5	Accuracy of measuring element	7
3.6	Measurement accuracy of mounted transmitter	8
3.7	Vibration resistance of measuring inset	8
3.8	Insulation resistance of measuring inset	8
3.9	Response times	9
3.10	Self-heating	9
3.11	Installation instructions	9
4	Connection heads	10
5	Extension tubes	11
5.1	Extension tube models	11
6	Process connections	12
6.1	SensyTemp TSP121 temperature sensor	12
6.2	SensyTemp TSP131 temperature sensor	12
7	Thermowells	13
7.1	Tubular thermowells	13
7.2	Drilled thermowells	15
8	Transmitter	16
9	Approvals	16
10	Tests and certificates	16
11	Additional information	16
11.1	Delivery times	16
11.2	Supplementary documents	16
12	Ordering information	17
12.1	SensyTemp TSP111	17
12.2	SensyTemp TSP121	22
12.3	SensyTemp TSP131	28

1 Overview of temperature sensors with an exchangeable measuring inset

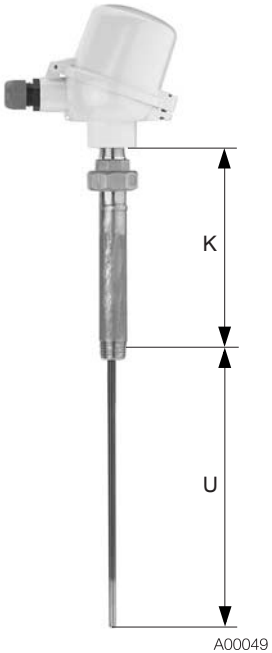
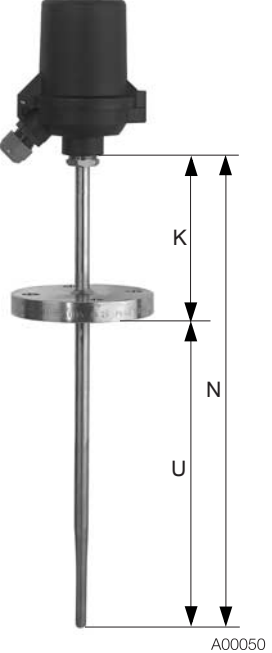
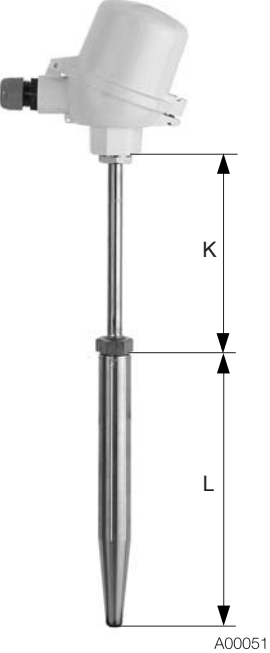
Type	TSP111	TSP121	TSP131
			
Thermowell properties	No thermowell, for installation in existing thermowell	Tube, tube base and welded process connection	Drilled bar stock material
Components	Measuring inset, extension tube with thermowell interface, connection head, transmitter, display	Measuring inset, thermowell with process interface, connection head, transmitter, display	Measuring inset, thermowell with process interface, extension tube, connection head, transmitter, display
Standard process interface	Installation by customer in existing thermowell	Screw-in thread, flange, compression fitting	Welded connections, screw-in thread, flange
Thermowell Ø (shaft/tip) [mm]	At installation site	9; 11; 12; 14; 11/6; 12/6; 12/9; 13,7; 13,7/6	18/9; 24/12.5; 32/13.5; 20/13.5; 23/13.5; 25/16; 17/13.5
Standard thermowell material	-	1.4404 (SS 316L) 1.4571 (SS 316Ti) 2.4819 (Hastelloy C276)	1.4571 (SS 316Ti), 1.4404 (SS 316L), 1.7335 (AISI F12), 1.5415 (AISI F1), 2.4819 (Hastelloy C276)
Standard ext. tube material	Stainless steel	One-piece thermowell	Stainless steel
Connection heads	BUZ, BUZH, BUZHD: Aluminum BUKH: Polyamide BEG: Stainless steel		
Output signal	Sensor signal, 4 ... 20 mA, HART, PROFIBUS PA, FOUNDATION Fieldbus		
Measuring insets	Compliant with DIN 43735, exchangeable		
Explosion protection class	ATEX II 1 G EEx ia IIC T6 ... T1 – zone 0, 1, 2 / connection head zone 1 ATEX II 1 D T133 ... T400 – zone 20, 21, 22 Note: Requirements for NAMUR NE24 recommendation are fulfilled by ATEX EEx i.		
Application	Comply with temperature limit for thermowell when measuring temperatures in tanks and pipelines in liquid and gaseous media.		
Temperature	Resistance thermometer < 600 °C, thermocouples < 1000 °C		
Pressure (depends on material, connection and stress data)	-	approx. 40 ... 100 bar	approx. 700 bar
Weight for standard designs	0.5 ... 2.5 kg	1.0 ... 4.0 kg	1.0 ... 6.0 kg

2 Overview of measuring insets

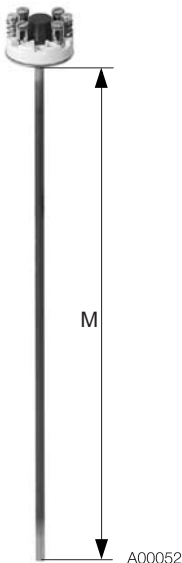
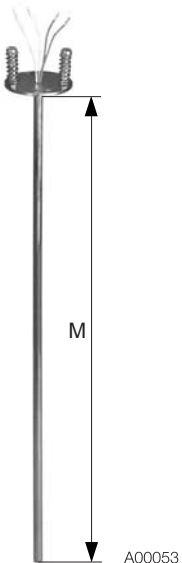
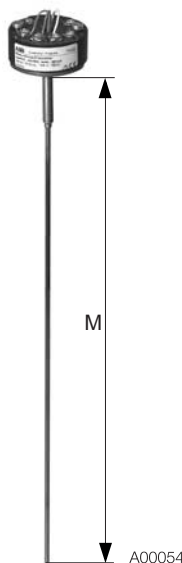
Type	Sheathed thermocouples and sheathed resistance thermometers		
			
Electrical connection	Terminal block	Flying leads	Installed ABB transmitter
Design	Mineral insulated cable: flexible, bendable, vibration resistant		
Measuring inset diameter	TSP111: Ø = 1 mm less than inside diameter of the thermowell		TSP121 / TSP131: Ø is adapted in factory to inside diameter of thermowell
Measuring inset length (M)	TSP111: Insertion length U + ext. tube length K + 25 mm TSP121: Nominal length N + 25 mm TSP131: Thermowell length L + ext. tube length K + 25 mm		
Standard sheath material	Resistance thermometers: 1.4571 (SS 316Ti) Thermocouples: 2.4816 (Inconel 600)		
Standard measuring elements	Resistance thermometers: Pt100 basic application (-50 ... 400 °C), single/dual, 3-/4-wire connection (EN 60751) Pt100 extended measuring range (-200 ... 600 °C), single/dual, 3-/4-wire connection Thermocouples: Type K, J and N, single/dual (EN 60584)		
Explosion protection class	ATEX II 1 G EEx ia IIC T6 ... T1 ATEX II 1 D T133 ... T400 Note: Requirements for NAMUR NE24 recommendation are fulfilled by ATEX EEx i.		
Application	Installation in TSP temperature sensors		
Spring travel	Approx. 10 mm		
Temperature	Resistance thermometers: Basic application: -50 ... 400 °C Extended vibration resistance: -50 ... 400 °C Extended measuring range: -200 ... 600 °C Thermocouples Type K, J and N: Approx. -40 ... 1000 °C		



Note

For higher resistance to vibrations, resistance measuring insets or thermocouples with higher resistance to vibrations are recommended.

For information on additional sensor models, sheath materials and diameters, contact your ABB sales representative.

3 General information

The permissible load for a temperature sensor depends on several factors:

Medium-specific factors	Installation-specific factors
- Medium	- Thermowell material:
- Viscosity	- Thermowell form
- Flow rate	- Insertion depth
- Pressure	- Sealable pressure of process connection
- Temperature	- Vibration

Considering the wide range of configuration options, it is not possible to provide generally applicable information. The following information provides recommended values. For conditions that vary significantly from those described herein, contact your ABB partner.

3.1 Ambient temperature at connection head

Aluminum or stainless steel, no transmitter	-40 ... 130 °C
Plastic, no transmitter	-40 ... 120 °C
Connection head with transmitter	-40 ... 85 °C
Connection head with LCD display	-20 ... 70 °C

ABB's standard cable gland is suited to temperatures between -20 and 100 °C. For temperatures outside this range, the appropriate cable gland must be installed.

3.2 Maximum process temperature

The maximum process temperature depends on the measuring element and thermowell material.

Thermowell material	Max. temperature
SS 316L / 1.4404	≤ 600 °C
SS 316 Ti / 1.4571	≤ 800 °C
Hastelloy C276 / 2.4816	≤ 1100 °C

These values are maximum values and do not take into consideration process-related stress. In individual cases, the values may be considerably lower.

3.3 Pressure and vibration resistance of thermowell

The permissible compressive loads for the various thermowells are provided in the following figures in accordance with DIN 43772 and are based on a range of temperatures.

The curves can also be applied to identical thermowell models.

Thermowell form 2 (material 1.4571)

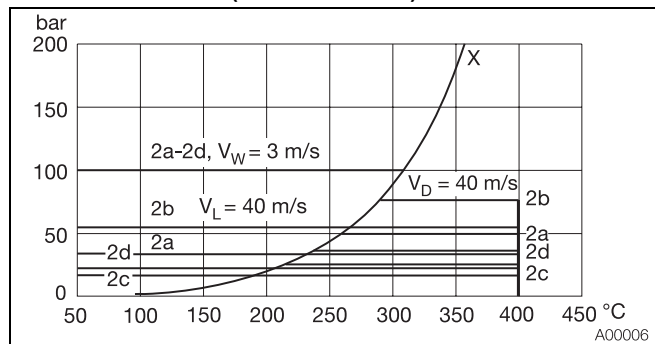

Fig. 1

X Vapor-pressure curve
V_L Flow rate in air
V_W Flow rate in water
V_D Flow rate in steam

Curve	Insertion depth [mm]	Thermowell diameter [mm]
2a	250	11
2b	250	14
2c	400	11
2d	400	14

Thermowell form 3 (material 1.4571)

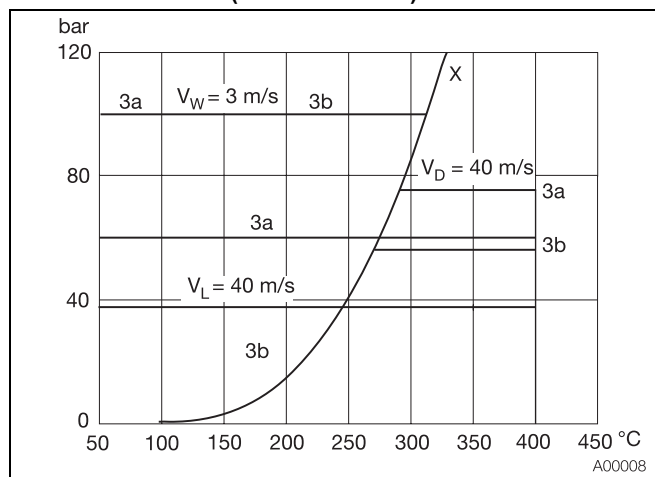

Fig. 2

X Vapor-pressure curve
V_L Flow rate in air
V_W Flow rate in water
V_D Flow rate in steam

Curve	Insertion depth [mm]	Thermowell diameter [mm]
3a	225	12/9
3b	285	12/9

Thermowell form 4 (material 1.4571)

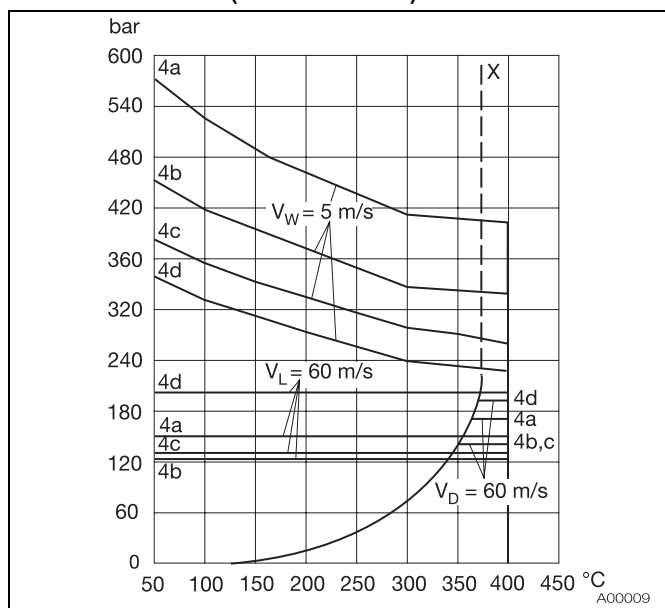

Fig. 3
X Vapor-pressure curve VL Flow rate in air
Vw Flow rate in water VD Flow rate in steam

Curve	Insertion depth [mm]	Thermowell diameter [mm]
4a	65	18
4b	125	24
4c	125	26
4d	125	32

Thermowell form 4 (material 1.5415)

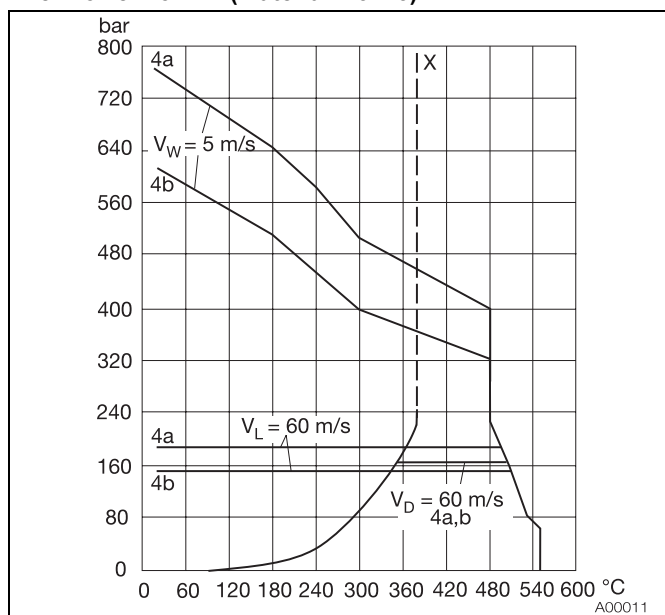

Fig. 4
X Vapor-pressure curve VL Flow rate in air
Vw Flow rate in water VD Flow rate in steam

Curve	Insertion depth [mm]	Thermowell diameter [mm]
4a	65	18
4b	125	24

Thermowell form 4 (material 1.7335 and 1.7380)

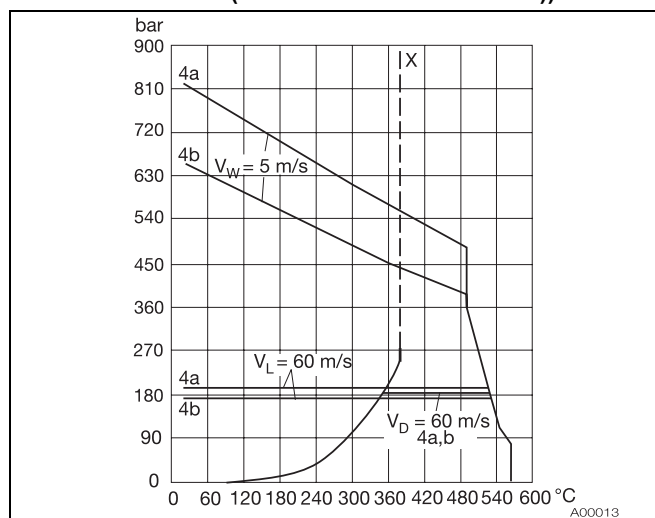

Fig. 5
X Vapor-pressure curve VL Flow rate in air
Vw Flow rate in water VD Flow rate in steam

Curve	Insertion depth [mm]	Thermowell diameter [mm]
4a	65	18
4b	125	24

i Note
The ABB standard thermowells are sufficiently robust for most industrial applications provided that design, material and length are properly selected.
Most thermowell failures are caused by flow-related vibrations. For this reason, ABB offers a stress analysis for ABB thermowells, based on the respective usage parameters.
The stress analysis is based on ASME standards and recognized theoretical methods, and is intended to support thermowell selection.
It is not, however, a guarantee against failure of the thermowell.

3.4 Measurement range of measuring inset

Resistance thermometers	
Basic application	-50 ... 400 °C
Extended vibration resistance	-50 ... 400 °C
Extended measuring range	-200 ... 600 °C
Thermocouple	
Type K	-40 ... 1000 °C
Type J	-40 ... 750 °C
Type N	-40 ... 1000 °C

3.5 Accuracy of measuring element

Resistance thermometers

Basic application	
Class B: $\Delta t = \pm (0.30 + 0.0050 t)$	-50 ... 400 °C
Class A: $\Delta t = \pm (0.15 + 0.0020 t)$	-30 ... 350 °C
$\Delta t = \pm (0.30 + 0.0050 t)$	-50 ... -30 / 350 ... 400 °C
1/3 Class B: $\Delta t = \pm (0.10 + 0.0017 t)$	0 ... 100 °C
$\Delta t = \pm (0.15 + 0.0020 t)$	-30 ... 0 / 100 ... 350 °C
$\Delta t = \pm (0.30 + 0.0050 t)$	-50 ... -30 / 350 ... 400 °C
Extended vibration resistance	
Class B: $\Delta t = \pm (0.30 + 0.0050 t)$	-50 ... 400 °C
Class A: $\Delta t = \pm (0.15 + 0.0020 t)$	-30 ... 350 °C
$\Delta t = \pm (0.30 + 0.0050 t)$	-50 ... -30 / 350 ... 400 °C
Extended measuring range	
Class B: $\Delta t = \pm (0.30 + 0.0050 t)$	-200 ... 600 °C
Class A: $\Delta t = \pm (0.15 + 0.0020 t)$	-200 ... 600 °C

Thermocouple

The measurement accuracy of the ABB standard thermocouples complies with international standard IEC 584 / EN 60584. Thermocouples compliant with ANSI MC96.1 are also available upon request. Since the values of both standards vary only marginally in the lower temperature range (up to approx. 300 °C), we recommend the use of thermocouples compliant with international standard IEC 584. The tolerance information must be defined in the table "Tolerance classes".

Tolerance classes

Standard	TE type	Class	Temperature range	Maximum deviation
EN 60584 / IEC 584	K (NiCr-Ni)	2	-40 ... 333 °C	±2.5 °C
			333 ... 1200 °C	±0.0075 x [t]
		1	-40 ... 375 °C	±1.5 °C
			375 ... 1000 °C	±0.0040 x [t]
	J (Fe-CuNi)	2	-40 ... 333 °C	±2.5 °C
			333 ... 750 °C	±0.0075 x [t]
		1	-40 ... 375 °C	±1.5 °C
			375 ... 750 °C	±0.0040 x [t]
	N (NiCrSiNiSi)	2	-40 ... 333 °C	±2.5 °C
			333 ... 1200 °C	±0.0075 x [t]
		1	-40 ... 375 °C	±1.5 °C
			375 ... 1000 °C	±0.0040 x [t]
Standard	TE type	Class	Temperature range	Maximum deviation
ANSI MC96.1	K (NiCr-Ni)	Standard	-0 ... 293 °C	±2.2 °C
			293 ... 1250 °C	±0.0075 x [t]
		Special	-0 ... 275 °C	±1.1 °C
			275 ... 1250 °C	±0.0040 x [t]
	J (Fe-CuNi)	Standard	-0 ... 293 °C	±2.2 °C
			293 ... 750 °C	±0.0075 x [t]
		Special	-0 ... 275 °C	±1.1 °C
			275 ... 750 °C	±0.0040 x [t]
	N (NiCrSiNiSi)	Standard	-0 ... 293 °C	±2.2 °C
			293 ... 1250 °C	±0.0075 x [t]
		Special	-0 ... 275 °C	±1.1 °C
			275 ... 1250 °C	±0.0040 x [t]

3.6 Measurement accuracy of mounted transmitter

For information on transmitter accuracy, refer to the documentation on transmitters.

3.7 Vibration resistance of measuring inset

Use of plastic-sheathed cables and special measuring elements, including their installation, results in a very high vibration resistance for all measuring insets of the TSP temperature sensor.

The acceleration values of 3 g, defined in accordance with EN 60751 (IEC 751) for additional requirements, are exceeded by all measuring inset models in TSP temperature sensors.

The following table provides an overview of the vibration resistance in accordance with EN 60751 for the measuring inset models (on hot side), as well as the temperature-sensitive sections and the non-bendable sections at the tip of the measuring inset.

Measuring inset-design	Vibration resistance EN 60751 (tip-tip)	temperature-sensitive section	non-bendable section
Pt100, Basic application (-50 ... 400 °C)	10 g	7 mm	30 mm
Pt100, Extended vibration resistance (-50 ... 400 °C)	60 g	10 mm	40 mm
Pt100, Extended measuring range (-200 ... 600 °C)	10 g	50 mm	60 mm
Thermocouple	60 g	3 mm	20 mm

3.8 Insulation resistance of measuring inset

The insulation resistance is measured between outside sheath and measuring circuit. In case of two measuring circuits, the insulation resistance between both measuring circuits is also measured.

The following applies for all measuring inset models:

$R_{iso} > 500 \text{ M}\Omega$ at 500 V DC/AC, 15 °C < T_u < 35 °C, relative humidity < 80%

As a result of a special process during manufacturing, ABB measuring insets also have outstanding insulation values at high temperatures.

3.9 Response times

Response times for temperature sensors from the TSP series are affected by the following:

- The thermowell used
- The thermal contact between thermowell and measuring inset

For TSP121 and TSP131 temperature sensors, the thermowell is adapted to the measuring inset, resulting in excellent heat transmission.

The following table shows typical response times for various ABB temperature sensors, measured in accordance with EN 60751 in water with 0.4 m/s and a temperature from 25 °C to 35 °C.

Resistance thermometers

Thermowell form	Diameter [mm]	T 0.5 [s]	T 0.9 [s]
2, 2G, 2F, 2G0	9	12	30
	11	14	38
3, 3G, 3F	12	12	30
2S, 2GS, 2FS, 2GS0	12	7	18
	14	7	18
4, 4F cone length 125	24	14	44
4, 4F cone length 65	24	20	63

Thermocouples

Thermowell form	Diameter [mm]	T 0.5 [s]	T 0.9 [s]
2, 2G, 2F, 2G0	9	10	24
	11	12	28
3, 3G, 3F	12	10	24
2S, 2GS, 2FS, 2GS0	12	6	14
	14	6	14
4, 4F cone length 125	24	10	40
4, 4F cone length 65	24	16	50

3.10 Self-heating

When using ABB transmitters, self-heating can be ignored.

3.11 Installation instructions



Note

For ATEX-certified components, observe the relevant safety instructions.

3.11.1 Insertion depth

The insertion depth of a temperature sensor can affect the accuracy of measurements:

- Improper sensor installation can result in measurement errors due to heat dissipation from the process connection and the tube or tank wall. (The size of the error depends on ambient conditions at the measuring point.)

Recommended insertion depth (to avoid heat dissipation errors)

Medium	Depth [mm]
Fluids	8 ... 10 x Ø thermowell tip
Gases	10 ... 15 x Ø thermowell tip

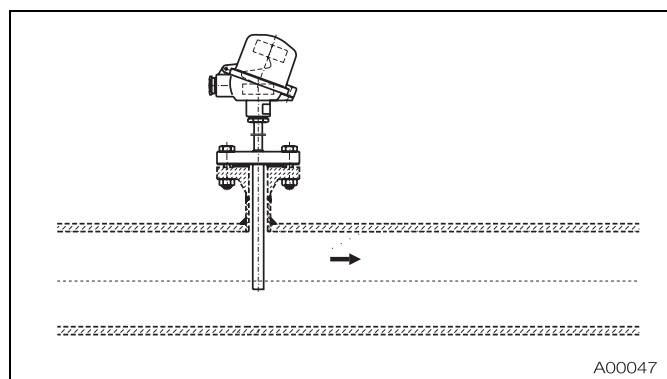

Fig. 6

3.11.2 Insufficient mounting diameter

- For tubes with very small nominal diameters, oblique insertion or insertion in an elbow is recommended; the thermowell tip must be positioned against the flow of the medium.

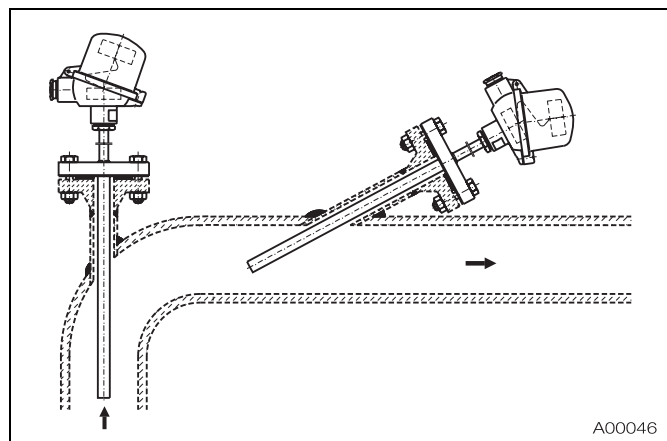

Fig. 7

4 Connection heads

The connection head performs the following functions:

- Housing of a transmitter or a terminal block
- Protect the connection area against adverse environmental effects

All ABB standard heads provide a protection class of at least IP 66, in combination with an ABB thermowell and the M20 x 1.5 cable gland.

Several connection heads are available, manufactured from various materials and with different cover locking systems.

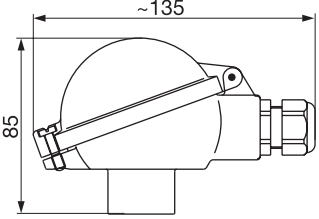
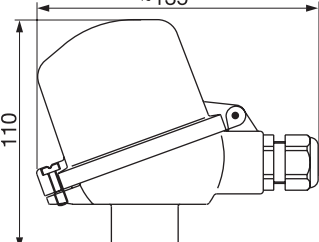
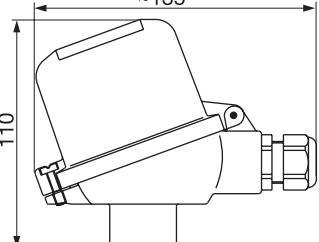
Head form	BUZ	BUZH	BUZHD
	 <p style="text-align: right;">A00012</p>	 <p style="text-align: right;">A00014</p>	 <p style="text-align: right;">A00015</p>
Material	Aluminum, epoxyd coated	Aluminum, epoxyd coated	Aluminum, epoxyd coated
Cover locking system	Hinged cover	Hinged cover	Hinged cover
LCD display	No	No	Yes
Transmitter mounting	On the measuring inset	In the cover (optional on the measuring inset)	On the measuring inset

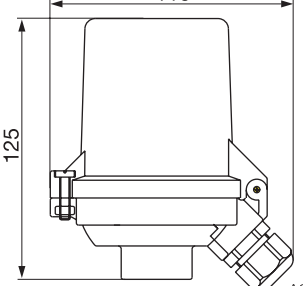
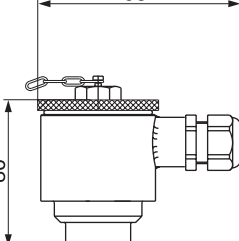
Head form	BUKH	BEG
	 <p style="text-align: right;">A00016</p>	 <p style="text-align: right;">A00017</p>
Material	Polyamide	Stainless steel
Cover locking system	Hinged cover	Screwed cover
LCD display	No	No
Transmitter mounting	In the cover (optional on the measuring inset)	On the measuring inset

Values in mm

5 Extension tubes

The extension tube is the component between the thermowell and connection head.

The extension tube performs the following functions:

- Bridge existing insulation
- Cooling section between the connection head and medium that protects the connecting point and built-in electronics against high temperatures.

	TSP121	TSP111 / TSP131
Ext. tube length K	Length from process connection to connection head	Length from thermocouple to connection head
Standard ext. tube length	130 mm ¹⁾	150 mm ¹⁾
Diameter	= Ø Thermowell	≥ 12 mm

¹⁾ In most cases, this is the optimal length in the connection head to avoid temperatures that are too high.

Affect of extension tube length [mm] on the temperature in the connection head [°C]

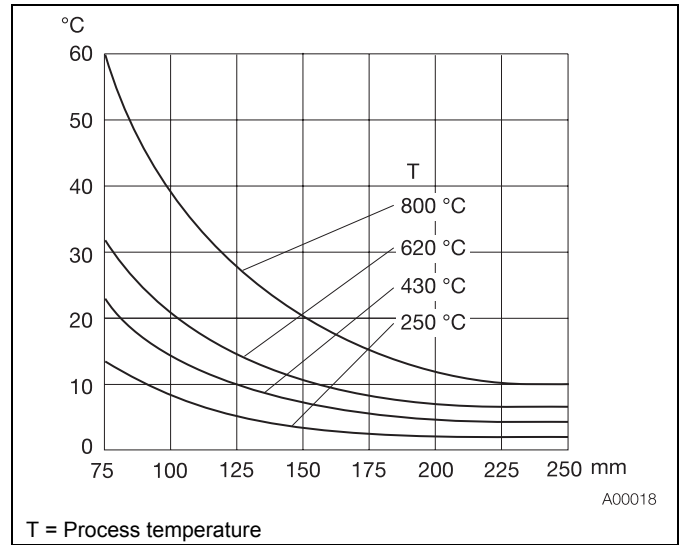

Fig. 8

5.1 Extension tube models

<p>A00019</p>	Cylindrical screw-in thread	Conical screw-in thread	Lock nuts, rotatable
	<p>A00025</p>	<p>A00024</p>	<p>A00023</p>
	1/2" NPT - 1/2" NPT, not separable (nipple)	1/2" NPT - 1/2" NPT, separable (nipple-union)	1/2" NPT - 1/2" NPT, separable, fitting in center (nipple-union-nipple)
<p>A00022</p>	<p>A00021</p>	<p>A00020</p>	

When ordering the "no ext. tube" design, ext. tube length K = 0 mm. As a result, only U must be provided. In this case, the installation length U is also the nominal length N.

6 Process connections

6.1 SensyTemp TSP121 temperature sensor

6.1.1 Weld-in /insertion thermowells

Type	Compression fitting
Straight (DIN43772-2)	G 1/2A, 1/2" NPT
Tapered (DIN43772-2)	
Stepped (ABB – 2S)	

6.1.2 Screwed thermowells

Type	Screw-in thread
Straight (DIN43772-2G)	G 1/2"A, G 3/4"A, G 1"A, 1/2" NPT, 3/4" NPT, 1" NPT, M20 x 1.5, M27 x 2, 1/2" BSPT, 3/4" BSPT, 1" BSPT
Tapered (DIN43772-3G)	
Stepped (ABB – 2GS)	
No ext. tube (ABB – 2G0)	G1/2A, 1/2" NPT
No ext. tube, stepped tip (ABB – 2GS0)	

6.1.3 Flange thermowells

Type	B1 flange, EN 1092-1	RF flange, ANSI/ASME B16.5	Tri-clamp flange BS 4825
Straight (DIN43772 – 2F)	DN25 PN40, DN40 PN40, DN50 PN40	1" 150 lbs., 1" 300 lbs., 1.5" 150 lbs., 1.5" 300 lbs., 1.5" 600 lbs., 2" 150 lbs., 2" 300 lbs., 2" 600 lbs	1.5", 2", 2.5", 3", 4"
Tapered (DIN43772-3F)			
Stepped (ABB – 2FS)			

6.2 SensyTemp TSP131 temperature sensor

6.2.1 Screwed thermowells

Type	Screw-in thread
Thermowell manufactured from bar stock material (ABB - PS)	1/2" NPT, 3/4" NPT, 1" NPT

6.2.2 Flange thermowells

Type	B1 flange, EN 1092-1	RF flange, ANSI/ASME B16.5	Tri-clamp flange BS 4825
Thermowell manufactured from bar stock material (ABB - PF)	DN25 PN40, DN40 PN40, DN50 PN40	1" 150 lbs., 1" 300 lbs., 1.5" 150 lbs., 1.5" 300 lbs., 1.5" 600 lbs., 2" 150 lbs., 2" 300 lbs., 2" 600 lbs.	2", 2.5", 3", 4"
Thermowell manufactured from bar stock material (DIN 43772 – 4F, F2 = 24 mm)			1.5", 2", 2.5", 3", 4"
Thermowell manufactured from bar stock material, fast-acting (DIN 43772 – 4F, F2 = 18 mm, ABB – 4FS)			

7 Thermowells

The thermowell performs the following functions:

- Protect against aggressive media, high process pressures and high speed flow
- Replace or recalibrate measuring unit without interrupting process

Depending on medium, temperature and process pressure, several different designs and materials are available. The thermowells are divided into 2 categories:

- Welded thermowells manufactured from pipe material (TSP121)
- Drilled thermowells manufactured from solid material (TSP131)

Available in accordance with DIN or ABB standards.

Use in highly aggressive media

- Stainless steel flange thermowells can have a special coating, e.g., with 0.5 mm E-CTFE (max. 150 °C).

Use with highly corrosive applications

- Thermowells can also have a tantalum sheath consisting of a single-sided, closed tube with 13 mm diameter and retaining ring. Requirements:
 - TSP121 with flange thermowells (form 2F or 3F)
 - 12 mm diameter
 - 1.4571 (SS 316Ti) or 1.4404 (SS 316L) materials



Note

When selecting the insertion and nominal lengths, it is recommended that you refer to the standard lengths. This ensures cost benefits and short delivery times based on proper parts inventory.

7.1 Tubular thermowells

Thermowell model	DIN 43772 – Form 2		DIN 43772 – Form 2G		DIN 43772 – Form 2F	
Thermowell form	 A00032		 A00030		 A00029	
Design	Straight shaft		Straight shaft		Straight shaft	
Material	Diameter (shaft/tip)	1.4571 12/12, 14/14 1.4404 12/12, 14/14	1.4571 9/9, 11/11, 12/12, 14/14 1.4404 12/12, 14/14 2.4819 ¹⁾ 13.7/13.7		1.4571 11/11, 12/12, 14/14 1.4404 12/12, 14/14 2.4819 ²⁾ 13.7/13.7	
Standard lengths	N = 230, 290, 380, 530		U = 100 / N = 230 U = 160 / N = 290 U = 250 / N = 380 U = 400 / N = 530		U = 100 / N = 230 U = 160 / N = 290 U = 250 / N = 380 U = 400 / N = 530	

Thermowell model	DIN 43772 – Form 3		DIN 43772 – Form 3G		DIN 43772 – Form 3F	
Thermowell form	 A00028		 A00027		 A00026	
Design	Tapered tip		Tapered tip		Tapered tip	
Material	Diameter (shaft/tip)	1.4571 12/9 1.4404 12/9	1.4571 12/9 1.4404 12/9		1.4571 12/9 1.4404 12/9	
Standard lengths	N = 230, 290, 380, 530		U = 100 / N = 230 U = 160 / N = 290 U = 250 / N = 380 U = 400 / N = 530		U = 100 / N = 230 U = 160 / N = 290 U = 250 / N = 380 U = 400 / N = 530	

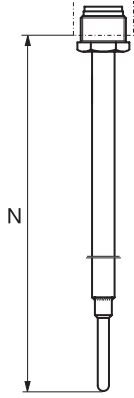
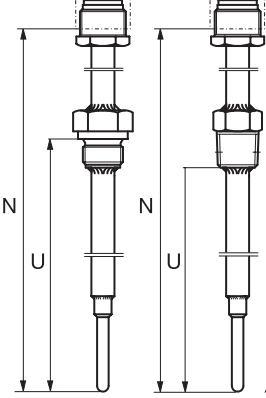
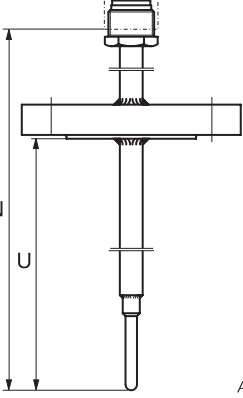
Thermowell model	ABB – Form 2S		ABB – Form 2GS		ABB – Form 2FS		
Thermowell form							
	A00033		A00035		A00034		
Design	Stepped tip		Stepped tip		Stepped tip		
Material	Diameter	1.4571	12/6, 14/6	1.4571	11/6, 12/6, 14/6	1.4571	11/6, 12/6, 14/6
	(shaft/tip)	1.4404	12/6, 14/6	1.4404	12/6, 14/6	1.4404	12/6, 14/6
				2.4819 ¹⁾	13.7/6	2.4819 ²⁾	13.7/6
Standard lengths	N = 230, 290, 380, 530		U = 100 / N = 230	U = 160 / N = 290	U = 100 / N = 230	U = 160 / N = 290	U = 250 / N = 380
			U = 250 / N = 380	U = 400 / N = 530	U = 250 / N = 380	U = 400 / N = 530	

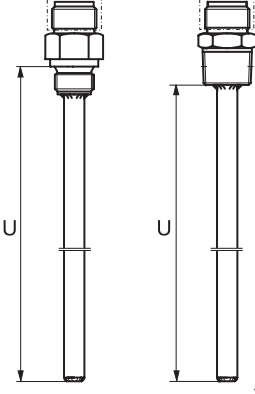
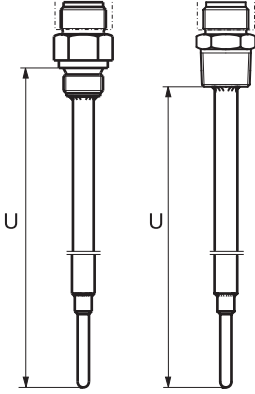
Thermowell model	ABB – 2G0		ABB – 2GS0		
Thermowell form					
	A00031		A00036		
Design	No extension tube, straight shaft		No extension tube, stepped tip		
Material	Diameter	1.4571 ¹⁾	9/9, 11/11	1.4571 ¹⁾	11/6
	(shaft/tip)				
Standard lengths	U = 100, 160, 250, 380		U = 100, 160, 250, 380		

Measurements in mm

¹⁾ only with G1/2A, 1/2" NPT thread

²⁾ 1.4571 backing flange, 2.4819 flange disc

7.2 Drilled thermowells

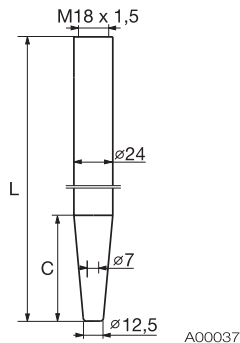
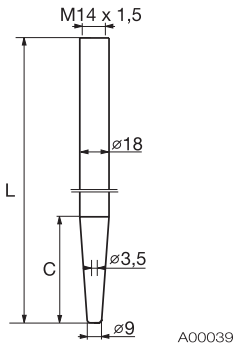
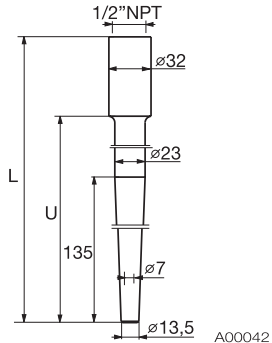
Thermowell model	DIN 43772 - Form 4 - M18 x 1.5	ABB – Form 4S (DIN 43772 – Form 4 - M14 x 1.5)	ABB - Form PW
Thermowell form			
Design	Weld-in thermowell	Weld-in thermowell	Weld-in thermowell
Material Diameter (shaft/tip)	1.4571, 1.4404, 24h7/12.5 1.7335, 1.5415	1.4571, 1.4404, 18h7/9 1.7335, 1.5415	1.4404, 1.4571, 2.4819, 32/13.5 1.4876, 2.4360, 2.4816
Standard lengths	L = 140 / C = 65 L = 200 / C = 65 L = 200 / C = 125 L = 260 / C = 125	L = 100 / C = 65 L = 140 / C = 65	U = 100, 150, 200, 250, 300, 350 L = U + 65

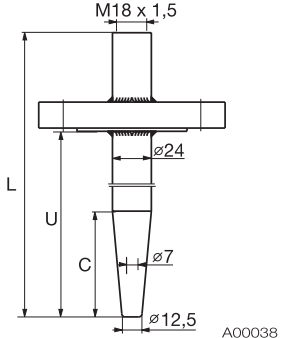
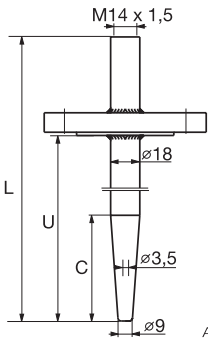
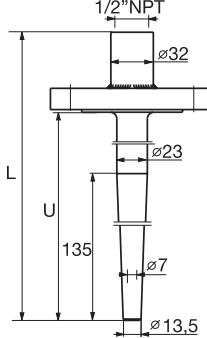
Thermowell model	DIN 43772 - Form 4F - M18 x 1.5	ABB – Form 4FS (DIN 43772 - Form 4FS M14 x 1.5)	ABB - Form PF
Thermowell form			
Design	Flange thermowell	Flange thermowell	Flange thermowell
Material Diameter (shaft/tip)	1.4571 24/12.5 1.4404	1.4571 18/9 1.4404	1.4404, 1.4571, 2.4819, 23/13.5 1.4876, 2.4360, 2.4816 ¹⁾
Standard lengths	L = 140 / C = 65 L = 200 / C = 65 L = 200 / C = 125 L = 260 / C = 125	L = 100 / C = 65 L = 140 / C = 65	U = 100, 150, 200, 250, 300, 350 L = U + 65

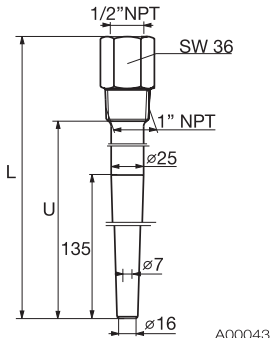
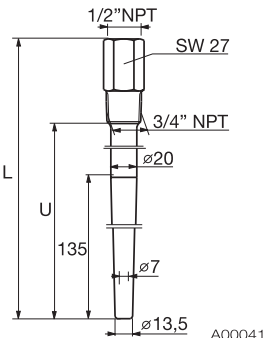
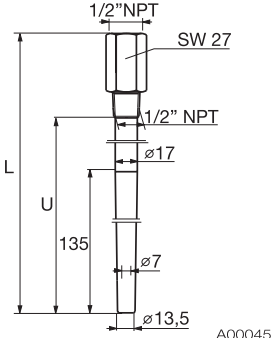
Thermowell model	ABB - Form PS		
Thermowell form			
Design	Screwed thermowell, 1" NPT thread	Screwed thermowell, 3/4" NPT thread	Screwed thermowell, 1/2" NPT thread
Material Diameter (shaft/tip)	1.4404, 1.4571, 2.4819, 25/16 1.4876, 2.4360, 2.4816	1.4404, 1.4571, 2.4819, 20/13.5 1.4876, 2.4360, 2.4816	1.4404, 1.4571, 2.4819, 17/13.5 1.4876, 2.4360, 2.4816
Standard lengths	U = 100, 150, 200, 250, 300, 350 L = U + 65	U = 100, 150, 200, 250, 300, 350 L = U + 65	U = 100, 150, 200, 250, 300, 350 L = U + 65

Measurements in mm

¹⁾ 1.4876, 2.4360, 2.4816, 2.4819 with 1.4571 backing flange and flange disc

8 Transmitter

Installing a transmitter has the following advantages:

- Reduces cost due to fewer cables
- Stronger sensor signal at measuring point and conversion to standard signal (also increases interference immunity)
- Option to install LCD display in the connection head. (Requires a BUZHD connection head).
- SIL2 with appropriately classified transmitter.

The output signal of a temperature sensor is determined by selecting the corresponding transmitter.

The following output signals are available:

- 4 ... 20 mA
- HART
- PROFIBUS PA
- FOUNDATION Fieldbus

LCD displays can be combined with the following transmitters:

- TTH300 (HART)
- TF02 (FOUNDATION Fieldbus)

i Note

For additional information, refer to the documentation on transmitters.

9 Approvals

TSP1X1 temperature sensors are approved for a variety of applications.

Approvals range from metrological to Ex certification for individual countries as well as EC-wide ATEX certificates.

These include the following certificates:

- ATEX EEx i No. PTB 01 ATEX 2200 X
- ATEX Dust ignition proof No. BVS 06 ATEX E 029
- GOST Russia
- GOST Kazakhstan
- GOST Ukraine

i Note

For devices with ATEX EEx d certification, refer to the documentation for the TSP3X1 temperature sensor.

ABB temperature sensors compliant with ATEX EEx i also meet requirements for the NAMUR NE21 recommendation.

10 Tests and certificates

To increase the safety and accuracy of your processes, ABB provides a number of mechanical and electrical tests. The results of these tests are certified in accordance with EN 10204.

The following EN 10204 certificates are available:

- Certificate of compliance with the order 2.1
- Acceptance test certificate 3.1 for the following checks:
 - Material confirmation for media parts in contact with media
 - Visual, metric and functional checks of temperature sensor
 - Helium leakage test of thermowell
 - X-ray inspection of thermowell
 - Dye penetration test at the weld seams of the thermowell
 - Compression test of thermowell
 - Comparison measurement for calibration of measuring inset
- Acceptance test certificate 3.2 is available upon request

For measurements requiring extremely high accuracy, ABB can calibrate the temperature sensor at its own DKD calibration lab.

When DKD calibration is performed, a separate certificate is provided for each temperature sensor.

Comparison measurements and DKD calibrations are performed on the measuring inset or, if applicable, on the transmitter.

To obtain accurate measurements, observe the **minimum length** for measuring inset:

- For low to medium temperatures: 100 ... 150 mm
- For temperatures above 500 °C: 300 ... 350 mm

These are recommended values. If in doubt, your ABB partner is available for on-site assistance.

For comparison measurements and DKD calibration, individual characteristics of the temperature sensor can be calculated and a separate transmitter can be programmed based on freestyle characteristics.

Adjusting the transmitter to the sensor characteristics can considerably improve the accuracy of the temperature sensor. When doing so, perform measurements at a minimum of three different temperatures.

11 Additional information

11.1 Delivery times

Typical delivery times for small (≤ 10 units) to medium (≤ 50 units) quantities and standard models are 3 to 20 days, depending on configuration.

11.2 Supplementary documents

Product	Data Sheet
Head mounted Temperature Transmitter	
TR04-Eco, TR04-Ex	10/11-8.14
TH01, TH01-Ex	3KDE115080R1003
TH02, TH02-Ex	10/11-8.19
TF12, TF12-Ex	10/11-8.26
TF02, TF02-Ex	10/11-8.25
TTH300	DS/TTH300
Exchangeable measuring insets	
SensyTemp TSA101	DS/TSA101

12 Ordering information

12.1 SensyTemp TSP111

Temperature Sensor SensyTemp TSP111 without thermowell, for light and medium duty applications	Variant digit No.	1 - 7	8	9	10	11	12	13	14	15	16	17	Code			
	Catalog No.	TSP111-														
Explosion protection / approval Without Intrinsic Safety: ATEX II 1 G EEx ia IIC T6 ... T1 - Zone 0, 1, 2 Dust ignition proof: ATEX II 1 D IP6X T133 ... T400 - Zone 20, 21, 22 Dust ignition proof and intrinsic safety: ATEX II 1 D IP6X T133 ... T400 and ATEX II 1 G EEx ia IIC T6 ... T1 - Zone 0, 1, 2, 20, 21, 22 ATEX II 3 G EEx nA II T6 ... T1 and ATEX II 3 D IP6X T133 ... T400 - Zone 2 and 22 Others																
Extension tube length K 150 mm Variable extension tube length (price per each commencing 100 mm)																
Thermowell connection Parallel thread G 1/2" A Parallel thread M14 x 1.5 Parallel thread M18 x 1.5 Parallel thread M20 x 1.5 Tapered thread 1/2" NPT Nipple 1/2" NPT - 1/2" NPT Nipple-union 1/2" NPT - 1/2" NPT Others																
Immersion length U U = 140 mm U = 200 mm U = 260 mm Acc. to customer specification (price per each commencing 100 mm)																
Measuring inset type Resistance thermometer, basic application, measuring range -50 ... 400 °C Resistance thermometer, extended vibration resistance, measuring range -50 ... 400 °C Resistance thermometer, extended measuring range -200 ... 600 °C Thermocouple Others																

Continued on next page

Temperature Sensor SensyTemp TSP111 without thermowell, for light and medium duty applications	Variant digit No.	1 - 7	14	15	16	17	18	19	20	21	22	23	Code				
	Catalog No.	TSP111-															
Measuring inset diameter																	
3 mm								4)									
6 mm																	
6 mm, tip with additional sleeve 8 mm																	
6 mm, tip with additional sleeve 10 mm																	
Others																	
Sensor type and wiring																	
1 x Pt100, 2-wire																	
1 x Pt100, 3-wire																	
1 x Pt100, 4-wire																	
2 x Pt100, 2-wire																	
2 x Pt100, 3-wire																	
2 x Pt100, 4-wire																	
1 x Type K (NiCr-Ni)																	
2 x Type K (NiCr-Ni)																	
1 x Type J (Fe-CuNi)																	
2 x Type J (Fe-CuNi)																	
1 x Type N (NiCrSi-NiSi)																	
2 x Type N (NiCrSi-NiSi)																	
Others																	
Sensor accuracy																	
Standard accuracy EN 60751 class B																	
Extended accuracy EN 60751 class A from -30 ... 350 °C																	
Extended accuracy EN 60751 class A from -200 ... 600 °C																	
Standard accuracy EN 60584 class 2																	
Extended accuracy EN 60584 class 1																	
High accuracy EN 60751 1/3 class B from 0 ... 100 °C																	
Others																	

4) Not available with Measuring inset type code S2

Continued on next page

5) Not available with Measuring inset type code T1

6) Not available with Measuring inset type code S2, T1

7) Not available with Measuring inset diameter code D3
and Explosion protection / approval code A1, A3, A4, B1

8) Not available with Measuring inset diameter code D3

9) Not available with Measuring inset type code S1, S2, D1

10) Not available with Measuring inset type code S2, D1, T1

11) Not available with Sensor type and wiring code P1, P4, K1, K2, J1, J2, N1, N2

12) Not available with Measuring inset type code S1, S2, T1

13) Not available with Sensor type and wiring code P1, P4, P5, P6, K1, K2, J1, J2, N1, N2

14) Not available with Sensor type and wiring code P1, P2, P3, P4, P5, P6

Temperature Sensor SensyTemp TSP111 without thermowell, for light and medium duty applications	Variant digit No.	1 - 7	18	19	20	21	22	23	24	25	26	27	Code				
	Catalog No.	TSP111-															
Connection head																	
BUZ / aluminium, hinged cover													B 1				
BUZH / aluminium, high cover, hinged													B 2				
BUZHD / aluminium, high cover with display, hinged							15)						B 3				
BUKH / polyamid, high cover, hinged							16, 15)						K 1				
BEG / stainless steel, screwed cover							16, 15)						E 1				
Others													Z 9				
Transmitter																	
Without transmitter, measuring inset with ceramic terminal block													17)	Y 1			
Without transmitter, measuring inset with flying leads													17)	Y 2			
TR04, fixed range, output signal 4 ... 20 mA													18, 17, 19)	R 1			
TR04-Ex, fixed range, output signal 4 ... 20 mA													20, 17, 19)	R 2			
TH01, programmable, output signal 4 ... 20 mA													18, 17)	P 1			
TH01-Ex, programmable, output signal 4 ... 20 mA													20, 17)	P 2			
TH02, programmable, output signal 4 ... 20 mA, HART													18, 17)	H 1			
TH02-Ex, programmable, output signal 4 ... 20 mA, HART													20, 17)	H 2			
TTH300, programmable, output signal 4 ... 20 mA, HART													18)	H 4			
TTH300 (Ex-version), programmable, output signal 4 ... 20 mA, HART													20)	H 5			
TF12, programmable, output PROFIBUS PA													18, 21)	F 1			
TF12-Ex, programmable, output PROFIBUS PA													20, 21)	F 2			
TF02, programmable, output FOUNDATION Fieldbus													18)	F 3			
TF02-Ex, programmable, output FOUNDATION Fieldbus													20)	F 4			
Others														Z 9			

- 15) Not available with Explosion protection / approval code A3, A4, B1
- 16) Not available with Thermowell connection code N2, N3
- 17) Not available with Connection head code B3
- 18) Not available with Explosion protection / approval code A1, A4, B1
- 19) Not available with Sensor type and wiring code P3, P6, K1, K2, J1, J2, N1, N2
- 20) Not available with Explosion protection / approval code Y0, A3, B1
- 21) Not available with Connection head code B1, B3, E1

Additional ordering information

Temperature Sensor SensyTemp TSP111		Code			
Name plate					
Stainless steel plate with TAG no.		T1			
Certificates					
Declaration of compliance with the order 2.1 acc. to EN 10204	32)	C4			
Inspection certificate 3.1 acc. to EN 10204 for visual, dimensional and functional test		C6			
Inspection certificate 3.1 acc. to EN 10204 for sensor calibration 1 x Pt100	5, 22, 32)	CD			
Inspection certificate 3.1 acc. to EN 10204 for sensor calibration 2 x Pt100	5, 23, 32)	CE			
Inspection certificate 3.1 acc. to EN 10204 for sensor calibration 1 x thermocouple	9, 24, 32)	CF			
Inspection certificate 3.1 acc. to EN 10204 for sensor calibration 2 x thermocouple	9, 25, 32)	CG			
Inspection certificate 3.1 acc. to EN 10204 for DKD sensor calibration 1 x Pt100, separate calibration certificate for each thermometer	5, 22, 32)	CH			
Inspection certificate 3.1 acc. to EN 10204 for DKD sensor calibration 2 x Pt100, separate calibration certificate for each thermometer	5, 23, 32)	CJ			
Inspection certificate 3.1 acc. to EN 10204 for DKD sensor calibration 1 x thermocouple, separate calibration certificate for each thermometer	9, 24, 32)	CK			
Inspection certificate 3.1 acc. to EN 10204 for DKD sensor calibration 2 x thermocouple, separate calibration certificate for each thermometer	9, 25, 32)	CL			
Others		CZ			
Temperatures for sensor calibration					
1 x Pt100 / 1 x TC					
0 °C / 32 °F	26)	V1			
100 °C / 212 °F	26)	V2			
0 °C and 100 °C / 32 °F and 212 °F	26)	V4			
As specified by customer	(price per calibration point) 26)	V6			
2 x Pt100 / 2 x TC					
0 °C / 32 °F	26)	V1			
100 °C / 212 °F	26)	V2			
0 °C and 100 °C / 32 °F and 212 °F	26)	V4			
As specified by customer	(price per calibration point) 26)	V6			
Temperatures for DKD calibration					
1 x Pt100 / 1 x TC					
0 °C / 32 °F	27)	D1			
100 °C / 212 °F	27)	D2			
0 °C and 100 °C / 32 °F and 212 °F	27)	D4			
As specified by customer	(price per calibration point) 27)	D6			
2 x Pt100 / 2 x TC					
0 °C / 32 °F	27)	D1			
100 °C / 212 °F	27)	D2			
0 °C and 100 °C / 32 °F and 212 °F	27)	D4			
As specified by customer	(price per calibration point) 27)	D6			

5) Not available with Measuring inset type code T1

Continued on next page

9) Not available with Measuring inset type code S1, S2, D1

22) Not available with Sensor type and wiring code P4, P5, P6, K1, K2, J1, J2, N1, N2

23) Not available with Sensor type and wiring code P1, P2, P3, K1, K2, J1, J2, N1, N2

24) Not available with Sensor type and wiring code P1, P2, P3, P4, P5, P6, K2, J2, N2

25) Not available with Sensor type and wiring code P1, P2, P3, P4, P5, P6, K1, J1, N1

26) Not available with Certificates code C4, C6, CH, CJ, CK, CL

27) Not available with Certificates code C4, C6, CD, CE, CF, CG

32) Price per order line

Additional ordering information

Temperature Sensor SensyTemp TSP111		Code			
Cable entry options					
1 x 1/2" NPT, without cable gland	30)	U2			
Others		UZ			
Transmitter measuring range					
-30 ... 60 °C	31)	A1			
-20 ... 40 °C	31)	A2			
0 ... 40 °C	31)	A3			
0 ... 60 °C	31)	A4			
0 ... 100 °C	31)	A5			
0 ... 120 °C	31)	A6			
0 ... 150 °C	31)	A7			
0 ... 200 °C	31)	A8			
0 ... 250 °C	31)	AF			
0 ... 300 °C	31)	AG			
0 ... 400 °C	31)	AH			
0 ... 600 °C	31)	AJ			
0 ... 800 °C	31)	AK			
0 ... 1000 °C	31, 9)	AL			
0 ... 1200 °C	31, 9)	AM			
0 ... 1400 °C	31, 9)	AN			
0 ... 1600 °C	31, 9)	AP			
Others	31)	AZ			

9) Not available with Measuring inset type code S1, S2, D1

30) Not available with Connection head code K1, E1

31) Not available with Transmitter code Y1, Y2

12.2 SensyTemp TSP121

Temperature Sensor SensyTemp TSP121 with welded thermowell, for light and medium duty applications	Variant digit No.	1 - 7	8	9	10	11	12	13	14	15	Code			
	Catalog No.	TSP121-												
Explosion protection / approval Without Intrinsic Safety: ATEX II 1 G EEx ia IIC T6 ... T1 - Zone 0, 1, 2 Dust ignition proof: ATEX II 1 D IP6X T133 ... T400 - Zone 20, 21, 22 Dust ignition proof and intrinsic safety: ATEX II 1 D IP6X T133 ... T400 and ATEX II 1 G EEx ia IIC T6 ... T1 - Zone 0, 1, 2, 20, 21, 22 ATEX II 3 G EEx nA II T6 ... T1 and ATEX II 3 D IP6X T133 ... T400 - Zone 2 and 22 Others				Y 0 A 1 A 3 A 4 B 1 Z 9										
Material of wetted parts Stainless steel 316 L / 1.4404 Stainless steel 316 Ti / 1.4571 Hastelloy C276 / 2.4819 (Backing flange stainless steel with flange disc Hastelloy C276) Others					S 1 S 2 N 1 Z 9									
Thermowell type Tubular thermowell with straight shaft (Form 2 acc. to DIN 43772) Flanged tubular thermowell with straight shaft (Form 2F acc. to DIN 43772) Screwed tubular thermowell with straight shaft (Form 2G acc. to DIN 43772) Tubular thermowell, tapered (Form 3 acc. to DIN 43772) Flanged tubular thermowell, tapered (Form 3F acc. to DIN 43772) Screwed tubular thermowell, tapered (Form 3G acc. to DIN 43772) Tubular thermowell, reduced tip (ABB Form 2S) Flanged tubular thermowell, reduced tip (ABB-Form 2FS) Screwed tubular thermowell, reduced tip (ABB-Form 2GS) Screwed tubular thermowell without extension, straight shaft (ABB-Form 2G0) Screwed tubular thermowell without extension, reduced tip (ABB-Form 2GS0) Others							A 1 A 2 A 3 C 1 C 2 C 3 B 1 B 2 B 3 A 4 B 4 Z 9							

- 1) Not available with Material of wetted parts code N1
2) Not available with Material of wetted parts code S1, N1

Continued on next page

Temperature Sensor SensyTemp TSP121 with welded thermowell, for light and medium duty applications	Variant digit No.	1	7	11	12	13	14	15	16	17	18	Code				
	Catalog No.	TSP121-														
Process connection																
Without process connection																
Adjustable compression fitting G 1/2", stainless steel material						3)						Y 0 0				
Adjustable compression fitting 1/2" NPT, stainless steel material						3, 1)						A 0 1				
Parallel thread G 1/2" A						4)						S 0 1				
Parallel thread G 3/4" A						5, 1)						S 0 2				
Parallel thread G 1" A						5, 1)						S 0 3				
Tapered thread 1/2" NPT						4)						S 0 4				
Tapered thread 3/4" NPT						5, 1)						S 0 5				
Tapered thread 1" NPT						5, 1)						S 0 6				
Parallel thread M20 x 1.5						5, 1)						S 0 7				
Parallel thread M27 x 2						5, 1)						S 0 8				
Tapered thread 1/2" BSPT						5, 1)						S 0 9				
Tapered thread 3/4" BSPT						5, 1)						S 1 0				
Tapered thread 1" BSPT						5, 1)						S 1 1				
Flange DN 25 PN10 ... PN40, Form B1 acc. to EN 1092-1						6)						F 0 3				
Flange DN 40 PN10 ... PN40, Form B1 acc. to EN 1092-1						6)						F 0 4				
Flange DN 50 PN10 ... PN40, Form B1 acc. to EN 1092-1						6)						F 0 5				
Flange 1" 150 lbs., Form RF acc. to ANSI/ASME B16.5						6)						F 0 7				
Flange 1" 300 lbs., Form RF acc. to ANSI/ASME B16.5						6)						F 0 8				
Flange 1.5" 150 lbs., Form RF acc. to ANSI/ASME B16.5						6)						F 1 1				
Flange 1.5" 300 lbs., Form RF acc. to ANSI/ASME B16.5						6)						F 1 2				
Flange 1.5" 600 lbs., Form RF acc. to ANSI/ASME B16.5						6)						F 1 3				
Flange 2" 150 lbs., Form RF acc. to ANSI/ASME B16.5						6)						F 1 5				
Flange 2" 300 lbs., Form RF acc. to ANSI/ASME B16.5						6)						F 1 6				
Flange 2" 600 lbs., Form RF acc. to ANSI/ASME B16.5						6)						F 1 7				
Tri-Clamp-flange 1" ... 1.5", ISO 2852 DN15 ... DN25 / DIN 32676 DIN25 ... DIN40 / BS 4825						6)						T 0 1				
Tri-Clamp-flange 2", ISO 2852 DN32 ... DN40 / DIN 32676 DIN50 / BS 4825						6)						T 0 2				
Tri-Clamp-flange 2.5", ISO 2852 DN50 / BS 4825						6)						T 0 3				
Tri-Clamp-flange 3", ISO 2852 DN65 / DIN 32676 DIN65 / BS 4825						6)						T 0 4				
Tri-Clamp-flange 4", DIN 32676 DIN100 / BS 4825						6)						T 0 5				
Others												Z 9 9				
Thermowell diameter																
9 mm												A 1				
11 mm												A 2				
12 mm												A 3				
14 mm												A 4				
13.7 mm												B 2				
Others												Z 9				

- 1) Not available with Material of wetted parts code N1
- 2) Not available with Material of wetted parts code S1, N1
- 3) Not available with Thermowell type code A2, A3, C2, C3, B2, B3, A4, B4
- 4) Not available with Thermowell type code A1, A2, C1, C2, B1, B2
- 5) Not available with Thermowell type code A1, A2, C1, C2, B1, B2, A4, B4
- 6) Not available with Thermowell type code A1, A3, C1, C3, B1, B3, A4, B4
- 7) Not available with Thermowell type code A1, A2, C1, C2, C3, B1, B2, B3, B4
- 8) Not available with Thermowell type code A1, C1, C2, C3, B1
- 9) Not available with Thermowell type code A4, B4
- 10) Not available with Thermowell type code C1, C2, C3, A4, B4
- 11) Not available with Material of wetted parts code S1, S2
- 12) Not available with Thermowell type code A1, C1, C2, C3, B1, A4, B4

Continued on next page

Temperature Sensor SensyTemp TSP121 with welded thermowell, for light and medium duty applications	Variant digit No.	1 - 7	19	20	21	22	23	24	25	26	Code			
	Catalog No.	TSP121-												
Immersion length U Without fixed immersion length U = 100 mm 13) U = 160 mm 13) U = 250 mm 13) U = 400 mm 13) Acc. to customer specification (price per each commencing 100 mm)			Y 0 U 1 U 3 U 5 U 7 Z 9											
Nominal length N N = 230 mm N = 290 mm N = 380 mm N = 530 mm 14, 15) Acc. to customer specification (price per each commencing 100 mm) Acc. to customer specification (price per each commencing 100 mm) (material Hastelloy C276)					N 1 N 3 N 5 N 7 Z 9 Z 9									
Measuring inset type Resistance thermometer, basic application, measuring range -50 ... 400 °C Resistance thermometer, extended vibration resistance, measuring range -50 ... 400 °C Resistance thermometer, extended measuring range -200 ... 600 °C Thermocouple Others						S 1 S 2 D 1 T 1 Z 9								
Sensor type and wiring 1 x Pt100, 2-wire 1 x Pt100, 3-wire 1 x Pt100, 4-wire 2 x Pt100, 2-wire 2 x Pt100, 3-wire 2 x Pt100, 4-wire 1 x Type K (NiCr-Ni) 2 x Type K (NiCr-Ni) 1 x Type J (Fe-CuNi) 2 x Type J (Fe-CuNi) 1 x Type N (NiCrSi-NiSi) 2 x Type N (NiCrSi-NiSi) Others							17) 17) 17) 18) 18) 18) 19) 19) 19) 19) 19) 19) 19)	P 1 P 2 P 3 P 4 P 5 P 6 K 1 K 2 J 1 J 2 N 1 N 2 Z 9						

13) Not available with Thermowell type code A1, C1, B1

14) Not available with Thermowell type code A2, A3, C2, C3, B2, B3, A4, B4
and Thermowell type code A1, C1, B1, A4, B4

15) Not available with Thermowell type code A2, A3, C2, C3, B2, B3, A4, B4 and Immersion length U code Y0, Z9

17) Not available with Measuring inset type code T1

18) Not available with Measuring inset type code S2, T1

19) Not available with Measuring inset type code S1, S2, D1

Continued on next page

Temperature Sensor SensyTemp TSP121 with welded thermowell, for light and medium duty applications	Variant digit No.	1 - 7	25	26	27	28	29	30	31	32	Code			
	Catalog No.	TSP121-												
Sensor accuracy														
Standard accuracy EN 60751 class B							17)							
Extended accuracy EN 60751 class A from -30 ... 350 °C							20, 21)							
Extended accuracy EN 60751 class A from -200 ... 600 °C							22, 23)							
Standard accuracy EN 60584 class 2							19)							
Extended accuracy EN 60584 class 1							19, 24)							
High accuracy EN 60751 1/3 class B from 0 ... 100 °C							20, 23)							
Others														
Connection head														
BUZ / aluminium, hinged cover														
BUZH / aluminium, high cover, hinged														
BUZHD / aluminium, high cover with display, hinged							25)							
BUKH / polyamid, high cover, hinged							25)							
BEG / stainless steel, screwed cover							25)							
Others														
Transmitter														
Without transmitter, measuring inset with ceramic terminal block							26)							
Without transmitter, measuring inset with flying leads							26)							
TR04, fixed range, output signal 4 ... 20 mA							27, 26, 28)							
TR04-Ex, fixed range, output signal 4 ... 20 mA							29, 26, 28)							
TH01, programmable, output signal 4 ... 20 mA							27, 26)							
TH01-Ex, programmable, output signal 4 ... 20 mA							29, 26)							
TH02, programmable, output signal 4 ... 20 mA, HART							27, 26)							
TH02-Ex, programmable, output signal 4 ... 20 mA, HART							29, 26)							
TTH300, programmable, output signal 4 ... 20 mA, HART							27)							
TTH300 (Ex-version), programmable, output signal 4 ... 20 mA, HART							29)							
TF12, programmable, output PROFIBUS PA							27, 30)							
TF12-Ex, programmable, output PROFIBUS PA							29, 30)							
TF02, programmable, output FOUNDATION Fieldbus							27)							
TF02-Ex, programmable, output FOUNDATION Fieldbus							29)							
Others														

- 17) Not available with Measuring inset type code T1
- 19) Not available with Measuring inset type code S1, S2, D1
- 20) Not available with Measuring inset type code S2, D1, T1
- 21) Not available with Sensor type and wiring code P1, P4, K1, K2, J1, J2, N1, N2
- 22) Not available with Measuring inset type code S1, S2, T1
- 23) Not available with Sensor type and wiring code P1, P4, P5, P6, K1, K2, J1, J2, N1, N2
- 24) Not available with Sensor type and wiring code P1, P2, P3, P4, P5, P6
- 25) Not available with Explosion protection / approval code A3, A4, B1
- 26) Not available with Connection head code B3
- 27) Not available with Explosion protection / approval code A1, A4, B1
- 28) Not available with Sensor type and wiring code P3, P6, K1, K2, J1, J2, N1, N2
- 29) Not available with Explosion protection / approval code Y0, A3, B1
- 30) Not available with Connection head code B1, B3, E1

Additional ordering information

Temperature Sensor SensyTemp TSP121		Code			
Name plate					
Stainless steel plate with TAG no.		T1			
Certificates					
Material monitoring with inspection certificate 3.1 acc. to EN 10204 for wetted parts	41)	C2			
Declaration of compliance with the order 2.1 acc. to EN 10204	41)	C4			
Inspection certificate 3.1 acc. to EN 10204 for visual, dimensional and functional test		C6			
Inspection certificate 3.1 acc. to EN 10204 for helium leak test		C7			
Inspection certificate 3.1 acc. to EN 10204 for X-ray test		C8			
Inspection certificate 3.1 acc. to EN 10204 for dye penetration test		C9			
Inspection certificate 3.1 acc. to EN 10204 for pressure test on thermowell		CB			
Inspection certificate 3.1 acc. to EN 10204 for sensor calibration 1 x Pt100	17, 31, 41)	CD			
Inspection certificate 3.1 acc. to EN 10204 for sensor calibration 2 x Pt100	17, 32, 41)	CE			
Inspection certificate 3.1 acc. to EN 10204 for sensor calibration 1 x thermocouple	19, 33, 41)	CF			
Inspection certificate 3.1 acc. to EN 10204 for sensor calibration 2 x thermocouple	19, 34, 41)	CG			
Inspection certificate 3.1 acc. to EN 10204 for DKD sensor calibration 1 x Pt100, separate calibration certificate for each thermometer	17, 31, 41)	CH			
Inspection certificate 3.1 acc. to EN 10204 for DKD sensor calibration 2 x Pt100, separate calibration certificate for each thermometer	17, 32, 41)	CJ			
Inspection certificate 3.1 acc. to EN 10204 for DKD sensor calibration 1 x thermocouple, separate calibration certificate for each thermometer	19, 33, 41)	CK			
Inspection certificate 3.1 acc. to EN 10204 for DKD sensor calibration 2 x thermocouple, separate calibration certificate for each thermometer	19, 34, 41)	CL			
Others		CZ			
Temperatures for sensor calibration		1 x Pt100 / 1 x TC			
0 °C / 32 °F	35)	V1			
100 °C / 212 °F	35)	V2			
0 °C and 100 °C / 32 °F and 212 °F	35)	V4			
As specified by customer	(price per calibration point)	35)	V6		
Temperatures for sensor calibration		2 x Pt100 / 2 x TC			
0 °C / 32 °F	35)	V1			
100 °C / 212 °F	35)	V2			
0 °C and 100 °C / 32 °F and 212 °F	35)	V4			
As specified by customer	(price per calibration point)	35)	V6		
Temperatures for DKD calibration		1 x Pt100 / 1 x TC			
0 °C / 32 °F	36)	D1			
100 °C / 212 °F	36)	D2			
0 °C and 100 °C / 32 °F and 212 °F	36)	D4			
As specified by customer	(price per calibration point)	36)	D6		
Temperatures for DKD calibration		2 x Pt100 / 2 x TC			
0 °C / 32 °F	36)	D1			
100 °C / 212 °F	36)	D2			
0 °C and 100 °C / 32 °F and 212 °F	36)	D4			
As specified by customer	(price per calibration point)	36)	D6		

17) Not available with Measuring inset type code T1

Continued on next page

19) Not available with Measuring inset type code S1, S2, D1

31) Not available with Sensor type and wiring code P4, P5, P6, K1, K2, J1, J2, N1, N2

32) Not available with Sensor type and wiring code P1, P2, P3, K1, K2, J1, J2, N1, N2

33) Not available with Sensor type and wiring code P1, P2, P3, P4, P5, P6, K2, J2, N2

34) Not available with Sensor type and wiring code P1, P2, P3, P4, P5, P6, K1, J1, N1

35) Not available with Certificates code C2, C4, C6, C7, C8, C9, CB, CH, CJ, CK, CL

36) Not available with Certificates code C2, C4, C6, C7, C8, C9, CB, CD, CE, CF, CG

41) Price per order line

Additional ordering information

Temperature Sensor SensyTemp TSP121		Code			
Thermowell options					
Thermowell stainless steel with additional tantalum sleeve		S1			
Thermowell coated with 0.5 mm E-CTFE / Halar, wetted parts incl. flange surface	1, 6)	S2			
Thermowell clean for oxygen service	1)	S9			
Others		SZ			
Flange connection options					
Flange facing with groove form C acc. to EN 1092-1	1, 37)	F1			
Flange facing with tongue form D acc. to EN 1092-1	1, 37)	F2			
Flange facing with RTJ surface acc. to ANSI/ASME B16.5	1, 38)	F3			
Others		FZ			
Cable entry options					
1 x 1/2" NPT, without cable gland	39)	U2			
Others		UZ			
Transmitter measuring range					
-30 ... 60 °C	40)	A1			
-20 ... 40 °C	40)	A2			
0 ... 40 °C	40)	A3			
0 ... 60 °C	40)	A4			
0 ... 100 °C	40)	A5			
0 ... 120 °C	40)	A6			
0 ... 150 °C	40)	A7			
0 ... 200 °C	40)	A8			
0 ... 250 °C	40)	AF			
0 ... 300 °C	40)	AG			
0 ... 400 °C	40)	AH			
0 ... 600 °C	40)	AJ			
0 ... 800 °C	40)	AK			
0 ... 1000 °C	40, 19)	AL			
0 ... 1200 °C	40, 19)	AM			
0 ... 1400 °C	40, 19)	AN			
0 ... 1600 °C	40, 19)	AP			
Others	40)	AZ			

1) Not available with Material of wetted parts code N1

6) Not available with Thermowell type code A1, A3, C1, C3, B1, B3, A4, B4

19) Not available with Measuring inset type code S1, S2, D1

37) Not available with Process connection code Y00, A01, A02, S01, S02, S03, S04, S05, S06, S07, S08, S09, S10, S11, F07, F08, F11, F12, F13, F15, F16, F17, T01, T02, T03, T04, T05

38) Not available with Process connection code Y00, A01, A02, S01, S02, S03, S04, S05, S06, S07, S08, S09, S10, S11, F03, F04, F05, F07, F11, F15, T01, T02, T03, T04, T05

39) Not available with Connection head code K1, E1

40) Not available with Transmitter code Y1, Y2

12.3 SensyTemp TSP131

Temperature Sensor SensyTemp TSP131 with drilled thermowell, for light and medium duty applications	Variant digit No.	1 - 7	8	9	10	11	12	13	14	15	Code			
	Catalog No.	TSP131-												
Explosion protection / approval Without Intrinsic Safety: ATEX II 1 G EEx ia IIC T6 ... T1 - Zone 0, 1, 2 Dust ignition proof: ATEX II 1 D IP6X T133 ... T400 - Zone 20, 21, 22 Dust ignition proof and intrinsic safety: ATEX II 1 D IP6X T133 ... T400 and ATEX II 1 G EEx ia IIC T6 ... T1 - Zone 0, 1, 2, 20, 21, 22 ATEX II 3 G EEx nA II T6 ... T1 and ATEX II 3 D IP6X T133 ... T400 - Zone 2 and 22 Others				Y 0 A 1 A 3 A 4 B 1 Z 9										
Material of wetted parts Stainless steel 316 L / 1.4404 Stainless steel 316 Ti / 1.4571 High temperature steel 1.7335 (13CrMo44) High temperature steel 1.5415 (15Mo3) Hastelloy C276 / 2.4819 (Backing flange stainless steel with flange disc Hastelloy C276) Others					S 1 S 2 W 1 W 3 N 1 Z 9									
Thermowell type Weld-in thermowell from bar stock material, acc. to DIN 43772, Form 4, diameter F2 = 24 mm Weld-in thermowell from bar stock material, acc. to DIN 43772, Form 4, quick response, diameter F2 = 18 mm (ABB-Form 4S) Flanged thermowell from bar stock material, acc. to DIN 43772, Form 4F, diameter F2 = 24 mm Flanged thermowell from bar stock material, acc. to DIN 43772, Form 4F, quick response, diameter F2 = 18 mm (ABB-Form 4FS) Weld-in thermowell from bar stock material, acc. to ABB standard, Form PW, diameter F2 = 32 mm Flanged thermowell from bar stock material, acc. to ABB standard, Form PF Screwed thermowell from bar stock material, acc. to ABB standard, Form PS Others							D 1 D 2 3) D 3 3) D 4 3) P 1 3) P 2 3) P 3 Z 9							

3) Not available with Material of wetted parts code W1, W3

Continued on next page

Temperature Sensor SensyTemp TSP131 with drilled thermowell, for light and medium duty applications	Variant digit No.	1 - 7	13	14	15	16	17	18	19	20	Code			
	Catalog No.	TSP131-												
Process connection														
Without process connection		4)		Y	0	0								
Tapered thread 1/2" NPT		5, 2)		S	0	4								
Tapered thread 3/4" NPT		5, 2)		S	0	5								
Tapered thread 1" NPT		5, 2)		S	0	6								
Flange DN 25 PN10 ... PN40, Form B1 acc. to EN 1092-1		6)		F	0	3								
Flange DN 40 PN10 ... PN40, Form B1 acc. to EN 1092-1		6)		F	0	4								
Flange DN 50 PN10 ... PN40, Form B1 acc. to EN 1092-1		6)		F	0	5								
Flange 1" 150 lbs., Form RF acc. to ANSI/ASME B16.5		6)		F	0	7								
Flange 1" 300 lbs., Form RF acc. to ANSI/ASME B16.5		6)		F	0	8								
Flange 1.5" 150 lbs., Form RF acc. to ANSI/ASME B16.5		6)		F	1	1								
Flange 1.5" 300 lbs., Form RF acc. to ANSI/ASME B16.5		6)		F	1	2								
Flange 1.5" 600 lbs., Form RF acc. to ANSI/ASME B16.5		6)		F	1	3								
Flange 2" 150 lbs., Form RF acc. to ANSI/ASME B16.5		6)		F	1	5								
Flange 2" 300 lbs., Form RF acc. to ANSI/ASME B16.5		6)		F	1	6								
Flange 2" 600 lbs., Form RF acc. to ANSI/ASME B16.5		6)		F	1	7								
Tri-Clamp-flange 1" ... 1.5", ISO 2852 DN15 ... DN25 / DIN 32676 DIN25 ... DIN40 / BS 4825		6)		T	0	1								
Tri-Clamp-flange 2", ISO 2852 DN32 ... DN40 / DIN 32676 DIN50 / BS 4825		6)		T	0	2								
Tri-Clamp-flange 2.5", ISO 2852 DN50 / BS 4825		6)		T	0	3								
Tri-Clamp-flange 3", ISO 2852 DN65 / DIN 32676 DIN65 / BS 4825		6)		T	0	4								
Tri-Clamp-flange 4", DIN 32676 DIN100 / BS 4825		6)		T	0	5								
Others				Z	9	9								
Extension tube length K														
150 mm											K 1			
Variable extension tube length (price per each commencing 100 mm)											Z 9			
Thermowell connection														
Parallel thread M14 x 1.5							7)				M 1			
Parallel thread M18 x 1.5							14)				M 2			
Tapered thread 1/2" NPT							10)				N 1			
Nipple 1/2" NPT - 1/2" NPT							10)				N 2			
Nipple-union 1/2" NPT - 1/2" NPT							10)				N 3			
Others											Z 9			

- 2) Not available with Material of wetted parts code W1, W3
- 4) Not available with Thermowell type code D3, D4, P2, P3
- 5) Not available with Thermowell type code D1, D2, D3, D4, P1, P2
- 6) Not available with Thermowell type code D1, D2, P1, P3
- 7) Not available with Thermowell type code D1, D3, P1, P2, P3
- 10) Not available with Thermowell type code D1, D2, D3, D4
- 14) Not available with Thermowell type code D2, D4, P1, P2, P3

Continued on next page

Temperature Sensor SensyTemp TSP131 with drilled thermowell, for light and medium duty applications	Variant digit No.	1 - 7	21	22	23	24	25	26	27	28	Code			
	Catalog No.	TSP131-												
Immersion length U														
Without fixed immersion length			Y	0										
U = 130 mm	8)		D	1										
U = 190 mm	8)		D	2										
U = 340 mm	9)		D	3										
U = 100 mm	10)		P	1										
U = 150 mm	10)		P	2										
U = 200 mm	10)		P	3										
U = 250 mm	10)		P	4										
U = 300 mm	10)		P	5										
U = 350 mm	10)		P	6										
Acc. to customer specification (price per each commencing 100 mm) (Thermowell type D3, D4)			Z	9										
Acc. to customer specification (price per each commencing 100 mm) (Thermowell type P1, P2, P3)			Z	9										
Acc. to customer specification (price per each commencing 100 mm) (Thermowell type P1, P2, P3, material Hastelloy C276)			Z	9										
Thermowell length L														
L = 110 mm, C = 65 mm	11)		D	1										
L = 140 mm, C = 65 mm	12)		D	3										
L = 200 mm, C = 65 mm	13)		D	4										
L = 200 mm, C = 125 mm	13)		D	5										
L = 260 mm, C = 125 mm	13)		D	6										
L = 410 mm, C = 275 mm	13)		D	7										
Acc. to ABB Standard (immersion length + 65 mm)	10)		P	1										
Acc. to customer specification			Z	9										
Measuring inset type														
Resistance thermometer, basic application, measuring range -50 ... 400 °C			S	1										
Resistance thermometer, extended vibration resistance, measuring range -50 ... 400 °C			S	2										
Resistance thermometer, extended measuring range -200 ... 600 °C			D	1										
Thermocouple			T	1										
Others			Z	9										
Sensor type and wiring														
1 x Pt100, 2-wire						15)		P	1					
1 x Pt100, 3-wire						15)		P	2					
1 x Pt100, 4-wire						15)		P	3					
2 x Pt100, 2-wire						16)		P	4					
2 x Pt100, 3-wire						16)		P	5					
2 x Pt100, 4-wire						16)		P	6					
1 x Type K (NiCr-Ni)						17)		K	1					
2 x Type K (NiCr-Ni)						17)		K	2					
1 x Type J (Fe-CuNi)						17)		J	1					
2 x Type J (Fe-CuNi)						17)		J	2					
1 x Type N (NiCrSi-NiSi)						17)		N	1					
2 x Type N (NiCrSi-NiSi)						17)		N	2					
Others								Z	9					

- 8) Not available with Thermowell type code D1, D2, P1, P2, P3
- 9) Not available with Thermowell type code D1, D2, D4, P1, P2, P3
- 10) Not available with Thermowell type code D1, D2, D3, D4
- 11) Not available with Thermowell type code D1, D3, D4, P1, P2, P3
- 12) Not available with Thermowell type code D3, D4, P1, P2, P3
- 13) Not available with Thermowell type code D2, D3, D4, P1, P2, P3
- 15) Not available with Measuring inset type code T1
- 16) Not available with Measuring inset type code S2, T1
- 17) Not available with Measuring inset type code S1, S2, D1

Continued on next page

Temperature Sensor SensyTemp TSP131 with drilled thermowell, for light and medium duty applications	Variant digit No.	1 - 7	27	28	29	30	31	32	33	34	Code			
	Catalog No.	TSP131-												
Sensor accuracy														
Standard accuracy EN 60751 class B					15)									
Extended accuracy EN 60751 class A from -30 ... 350 °C					18, 19)									
Extended accuracy EN 60751 class A from -200 ... 600 °C					20, 21)									
Standard accuracy EN 60584 class 2					17)									
Extended accuracy EN 60584 class 1					17, 22)									
High accuracy EN 60751 1/3 class B from 0 ... 100 °C					18, 21)									
Others														
Connection head														
BUZ / aluminium, hinged cover														
BUZH / aluminium, high cover, hinged														
BUZHD / aluminium, high cover with display, hinged					23)									
BUKH / polyamid, high cover, hinged					24, 23)									
BEG / stainless steel, screwed cover					24, 23)									
Others														
Transmitter														
Without transmitter, measuring inset with ceramic terminal block														
Without transmitter, measuring inset with flying leads														
TR04, fixed range, output signal 4 ... 20 mA														
TR04-Ex, fixed range, output signal 4 ... 20 mA														
TH01, programmable, output signal 4 ... 20 mA														
TH01-Ex, programmable, output signal 4 ... 20 mA														
TH02, programmable, output signal 4 ... 20 mA, HART														
TH02-Ex, programmable, output signal 4 ... 20 mA, HART														
TTH300, programmable, output signal 4 ... 20 mA, HART														
TTH300 (Ex-version), programmable, output signal 4 ... 20 mA, HART														
TF12, programmable, output PROFIBUS PA														
TF12-Ex, programmable, output PROFIBUS PA														
TF02, programmable, output FOUNDATION Fieldbus														
TF02-Ex, programmable, output FOUNDATION Fieldbus														
Others														

- 15) Not available with Measuring inset type code T1
- 17) Not available with Measuring inset type code S1, S2, D1
- 18) Not available with Measuring inset type code S2, D1, T1
- 19) Not available with Sensor type and wiring code P1, P4, K1, K2, J1, J2, N1, N2
- 20) Not available with Measuring inset type code S1, S2, T1
- 21) Not available with Sensor type and wiring code P1, P4, P5, P6, K1, K2, J1, J2, N1, N2
- 22) Not available with Sensor type and wiring code P1, P2, P3, P4, P5, P6
- 23) Not available with Explosion protection / approval code A3, A4, B1
- 24) Not available with Thermowell connection code N2, N3
- 25) Not available with Connection head code B3
- 26) Not available with Explosion protection / approval code A1, A4, B1
- 27) Not available with Sensor type and wiring code P3, P6, K1, K2, J1, J2, N1, N2
- 28) Not available with Explosion protection / approval code Y0, A3, B1
- 29) Not available with Connection head code B1, B3, E1

Additional ordering information

Temperature Sensor SensyTemp TSP131		Code		
Name plate				
Stainless steel plate with TAG no.		T1		
Certificates				
Material monitoring with inspection certificate 3.1 acc. to EN 10204 for wetted parts	43)	C2		
Declaration of compliance with the order 2.1 acc. to EN 10204	43)	C4		
Inspection certificate 3.1 acc. to EN 10204 for visual, dimensional and functional test		C6		
Inspection certificate 3.1 acc. to EN 10204 for helium leak test		C7		
Inspection certificate 3.1 acc. to EN 10204 for X-ray test		C8		
Inspection certificate 3.1 acc. to EN 10204 for dye penetration test		C9		
Inspection certificate 3.1 acc. to EN 10204 for pressure test on thermowell		CB		
Inspection certificate 3.1 acc. to EN 10204 for sensor calibration 1 x Pt100	15, 30, 43)	CD		
Inspection certificate 3.1 acc. to EN 10204 for sensor calibration 2 x Pt100	15, 31, 43)	CE		
Inspection certificate 3.1 acc. to EN 10204 for sensor calibration 1 x thermocouple	17, 32, 43)	CF		
Inspection certificate 3.1 acc. to EN 10204 for sensor calibration 2 x thermocouple	17, 33, 43)	CG		
Inspection certificate 3.1 acc. to EN 10204 for DKD sensor calibration 1 x Pt100, separate calibration certificate for each thermometer	15, 30, 43)	CH		
Inspection certificate 3.1 acc. to EN 10204 for DKD sensor calibration 2 x Pt100, separate calibration certificate for each thermometer	15, 31, 43)	CJ		
Inspection certificate 3.1 acc. to EN 10204 for DKD sensor calibration 1 x thermocouple, separate calibration certificate for each thermometer	17, 32, 43)	CK		
Inspection certificate 3.1 acc. to EN 10204 for DKD sensor calibration 2 x thermocouple, separate calibration certificate for each thermometer	17, 33, 43)	CL		
Others		CZ		
Temperatures for sensor calibration				
1 x Pt100 / 1 x TC				
0 °C / 32 °F	34)	V1		
100 °C / 212 °F	34)	V2		
0 °C and 100 °C / 32 °F and 212 °F	34)	V4		
As specified by customer	(price per calibration point) 34)	V6		
2 x Pt100 / 2 x TC				
0 °C / 32 °F	34)	V1		
100 °C / 212 °F	34)	V2		
0 °C and 100 °C / 32 °F and 212 °F	34)	V4		
As specified by customer	(price per calibration point) 34)	V6		
Temperatures for DKD calibration				
1 x Pt100 / 1 x TC				
0 °C / 32 °F	35)	D1		
100 °C / 212 °F	35)	D2		
0 °C and 100 °C / 32 °F and 212 °F	35)	D4		
As specified by customer	(price per calibration point) 35)	D6		
2 x Pt100 / 2 x TC				
0 °C / 32 °F	35)	D1		
100 °C / 212 °F	35)	D2		
0 °C and 100 °C / 32 °F and 212 °F	35)	D4		
As specified by customer	(price per calibration point) 35)	D6		

15) Not available with Measuring inset type code T1

Continued on next page

17) Not available with Measuring inset type code S1, S2, D1

30) Not available with Sensor type and wiring code P4, P5, P6, K1, K2, J1, J2, N1, N2

31) Not available with Sensor type and wiring code P1, P2, P3, K1, K2, J1, J2, N1, N2

32) Not available with Sensor type and wiring code P1, P2, P3, P4, P5, P6, K2, J2, N2

33) Not available with Sensor type and wiring code P1, P2, P3, P4, P5, P6, K1, J1, N1

34) Not available with Certificates code C2, C4, C6, C7, C8, C9, CB, CH, CJ, CK, CL

35) Not available with Certificates code C2, C4, C6, C7, C8, C9, CB, CD, CE, CF, CG

43) Price per order line

Additional ordering information

Temperature Sensor SensyTemp TSP131		Code			
Thermowell options					
Thermowell incl. tests and certificates acc. to NACE MR 0175	36, 10)	S8			
Thermowell clean for oxygen service	2)	S9			
Others		SZ			
Flange connection options					
Flange facing with groove form C acc. to EN 1092-1	2, 37)	F1			
Flange facing with tongue form D acc. to EN 1092-1	2, 37)	F2			
Flange facing with RTJ surface acc. to ANSI/ASME B16.5	2, 38)	F3			
Flange full penetration welded	2, 39, 40)	F4			
Others		FZ			
Cable entry options					
1 x 1/2" NPT, without cable gland	41)	U2			
Others		UZ			
Transmitter measuring range					
-30 ... 60 °C	42)	A1			
-20 ... 40 °C	42)	A2			
0 ... 40 °C	42)	A3			
0 ... 60 °C	42)	A4			
0 ... 100 °C	42)	A5			
0 ... 120 °C	42)	A6			
0 ... 150 °C	42)	A7			
0 ... 200 °C	42)	A8			
0 ... 250 °C	42)	AF			
0 ... 300 °C	42)	AG			
0 ... 400 °C	42)	AH			
0 ... 600 °C	42)	AJ			
0 ... 800 °C	42)	AK			
0 ... 1000 °C	42, 17)	AL			
0 ... 1200 °C	42, 17)	AM			
0 ... 1400 °C	42, 17)	AN			
0 ... 1600 °C	42, 17)	AP			
Others	42)	AZ			

2) Not available with Material of wetted parts code W1, W3

10) Not available with Thermowell type code D1, D2, D3, D4

17) Not available with Measuring inset type code S1, S2, D1

36) Not available with Material of wetted parts code S2, W1, W3

37) Not available with Process connection code Y00, S04, S05, S06, F07, F08, F11, F12, F13, F15, F16, F17, T01, T02, T03, T04, T05

38) Not available with Process connection code Y00, S04, S05, S06, F03, F04, F05, F07, F11, F15, T01, T02, T03, T04, T05

39) Not available with Thermowell type code D1, D2, D3, D4, P1, P3

40) Not available with Process connection code Y00, S04, S05, S06, F07, F08, T01, T02, T03, T04, T05

41) Not available with Connection head code K1, E1

42) Not available with Transmitter code Y1, Y2

ABB provides expert and comprehensive consulting services
in more than 100 countries worldwide.

www.abb.com/temperature

ABB is continually improving its products. As a
result, technical information in this document is
subject to change.

Printed in the Fed. Rep. of Germany (04.2006)

© ABB 2006

3KXT161001R1001



ABB Limited

Salterbeck Trading Estate
Workington, Cumbria
CA14 5DS
UK
Tel: +44 (0)1946 830 611
Fax: +44 (0)1946 832 661

ABB Inc.

125 E. County Line Road
Warminster, PA 18974
USA
Tel: +1 215 674 6000
Fax: +1 215 674 7183

ABB Automation Products GmbH

Borsigstr. 2
63755 Alzenau
Germany
Tel: +49 551 905-534
Fax: +49 551 905-555
CCC-support.deapr@de.abb.com