

PB/F - PB/FL type PowerCube Installation and service instructions

Index

1. Packing and transport	2
2. Control on receipt	3
3. Storage	4
4. Handling	4
5. Description	6
6. Instructions for operating the apparatus and operation sequence of the units	20
7. Installation	24
8. Putting into service	25
9. Periodic checks	26
10. Maintenance operations	27
11. Accessories and spare parts	28



For your safety!

- Make sure that the room is suitable for the installation of electrical apparatus.
- Make sure that all the installation, putting into service and maintenance operations are carried out by skilled personnel with in-depth knowledge of the apparatus.
- Make sure that all the installation, service and maintenance operations comply with standard and legal requirements for constructing the installations in accordance with the regulations for safety in the workplace.
- Strictly follow this instruction manual.
- Make sure that the ratings are not exceeded while the apparatus is in service.
- Pay the utmost attention to the notes shown in the manual by the following symbol:



- Make sure that the personnel working on the apparatus have this manual to hand and all the information required for correct intervention.



Responsible behaviour safeguards your own and others' safety!

For any requests, please contact the ABB Assistance Service.

Introduction

The instructions in this manual refer to standardised PowerCube PB/F medium voltage fixed parts.

For correct use of the apparatus, please read the manual carefully.

PowerCube PB/F fixed parts are designed for a large number of installation configurations.

However, they do allow further technical and constructional modifications to satisfy special installation requirements.

Consequently, the information given below may sometimes not contain instructions concerning special configurations requested by the customer.

Apart from to the manual, it is therefore always necessary to consult the latest technical documentation (circuit and wiring diagrams, foundation plans, any protection coordination studies, etc.), especially regarding any variants requested in relation to the standardised configurations.

For maintenance use only original spare parts. For any further information, refer to Technical Catalogue 1VCP000253.

For instructions regarding the apparatus (circuit-breakers, contactors ...), refer to the relative instruction booklets.

1. Packing and transport



Follow the symbols and instructions shown on the packing carefully

Each fixed part is packed according to the shipping and storage requirements of the customer.

Each fixed part is protected by a plastic cover to prevent any water entering during the loading and unloading stages and to keep it free of dust during storage.

The fixed parts must be placed on the transport vehicle platform back-to-back and transversely, placing materials between them suitable for absorbing any compression and to avoid any direct contact between the surfaces of the various groups.

Special longitudinal members must be placed on the platform to space each fixed part and prevent it moving either longitudinally or transversely.

The fixed parts must be anchored to the structure of the vehicle with ropes, so that there is not deformation and to prevent tilting on bends or in the case of sudden stops.

The transport vehicle must also have a tarpaulin cover over the whole load.

The resting points of the lifting means must have a specific capacity to ensure proper weight distribution.

To unload the fixed parts, there must be an area at the same level and with dimensions not less than 3 x 2 m in front of the access to the warehouse or switchboard room.

See paragraph 4 for handling.

Small differences in level can be compensated with temporary structures made using wooden boards.

Unloading must be carried out with the utmost care using suitable lifting equipment for the weight of each group.

Special attention must be paid and the specific risks analysed for working in areas with live overhead lines.

2. Control on receipt



- While handling the unit do not put stress on the insulating parts.
- Before performing any operation make sure that the operating device springs are discharged and the apparatus is in the open position.

On receipt, immediately check the packing and the state of the apparatus.

Open the packing as shown in para. 4., taking care not to damage its materials. Check that no damage has occurred during transport and make sure that the nameplate data (fig. 1) corresponds to what is specified in the ABB order acknowledgement and in the shipping note.

Should any damage or irregularity be found in the supply, immediately notify ABB (directly, through the agent or the supplier) and the carrier who delivered the goods.

Notification of any irregularity, even after receipt, must indicate the fixed part serial number shown on the nameplate located on the module itself.

The fixed parts are only supplied complete with the accessories specified at the time of ordering and confirmed in the order acknowledgement sent by ABB.

The documents enclosed in the shipping packing are:

- adhesive labels showing the addressee and product type;
- this instruction manual;
- the test report;
- the electrical diagram.

2.1. Nameplate data

1	ABB	
3	SERIAL NUMBER
	YEAR 2006	IEC 60694
2	PowerCube	PBF
	INSTRUCTION MANUAL	1VCD600530
	RATED VOLTAGE	Ur 12 kV
	RATED INSULATION VOLTAGE	Up 75 kV
	POWER FREQUENCY WITHSTAND VOLTAGE	Ud 28 kV
	FREQUENCY	fr 50/60 Hz
4	RATED CURRENT	Ir 1250 A
	WITH FORCED VENTILATION BY ABB DESIGN	Ir A
	SHORT TIME WITHSTAND CURRENT	Ik 31.5 kA
	PEAK CURRENT	Ip 80 kA
	SHORT-CIRCUIT TIME	tk 1 s
	 1VC1AG00048184	
	Made by ABB	

Caption

- 1 Trade mark
- 2 Enclosure type
- 3 Serial number
- 4 Electrical characteristics
- 5 Standards

Fig. 1

3. Storage



Please contact ABB in case of special storage conditions.

If the apparatus has to be stored before installation, on request suitable packing for the conditions specified can be provided.

On receipt, the fixed part must be unpacked and checked as described in “Control on receipt” (chapter 2), and then put back in the packing again using the original materials.

Fixed parts must be stored in a dry, dust-free, non-corrosive place, at a temperature ranging from – 5 °C to + 45 °C without significant changes. If this is not possible, store the fixed parts in a well-ventilated room, cover them with tarpaulins or waterproof sheets (e.g.: polyethylene).

The package contains dehydrating bags that must be replaced every six months.

For special requirements, please contact us.

4. Handling

4.1. Fixed parts

Each fixed part is usually fixed onto a wooden platform. Handling should preferably be carried out by means of bridge or mobile cranes. Otherwise, use rollers or fork lift trucks. Weights and dimensions of the various sections are indicated in the shipping documents and on the plant drawings.

Fixed parts handling



To handle the fixed parts containing the apparatus (circuit-breaker, contactor or service truck), it is compulsory to use the lifting eyebolts provided with the module.

4.1.1. Handling with bridge or mobile crane and unpacking

Handling the fixed part in the wood packing

Lifting by means of a crane must be carried out using the circular slings (1) (fig. 2).

The slings must be inserted according to the lifting symbols marked on the crate.

Weight and lifting opening angle must be taken into account when choosing the circular slings.

Unpacking

- Remove the nails and crate lid and sides;
- loosen the screws fixing the fixed part to the pallet (if present);
- lift the module by means of the crane;
- slide the pallet out from under the fixed part;
- position the unloading shims;
- lower the module onto the shims using the crane.

After unpacking it, lift the module by means of a crane, using the special eyebolts (1) (fig. 3) and the ropes fitted with safety spring catches.

After installation, remove the eyebolts (1).

4.1.2. Handling by means of transpallets or fork lift trucks



- **The floor on which the transpallets or fork lift trucks run must be completely**
- **Move the fixed part, avoiding any bumps which might turn it over.**

For greater stability, only lift the fixed part enough to allow handling. Also check levelness of the forks.

Handling the module in the wooden crate

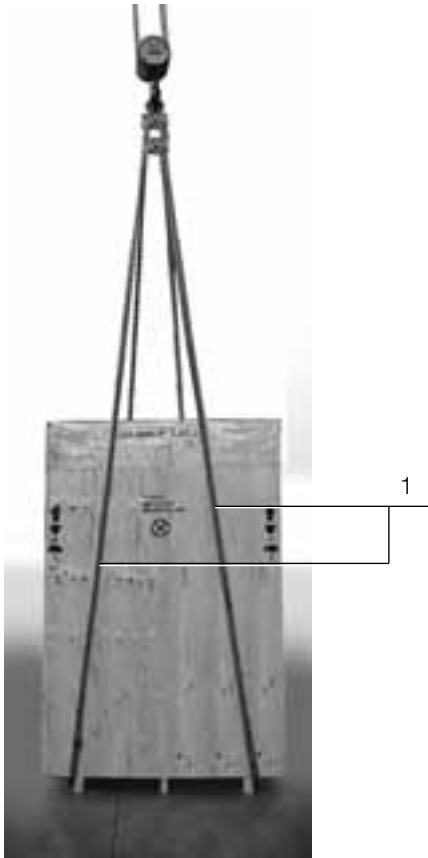

Fig. 2

Module lifting

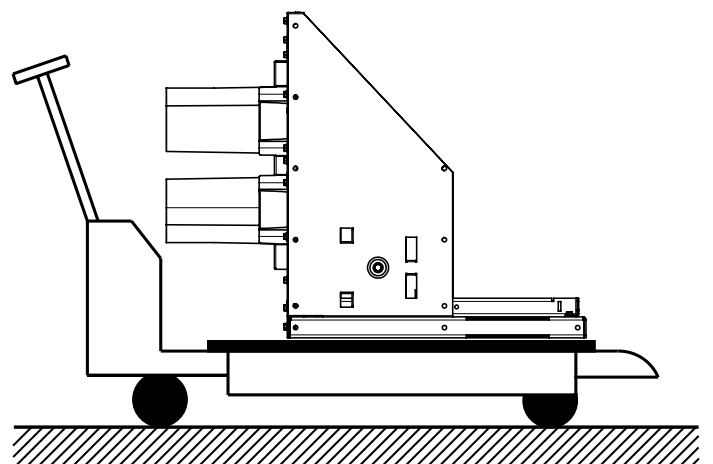

Fig. 3



Lifting a fixed part packed in a wooden crate.

Fig. 4



Fixed part handling.

Fig. 5

5. Description

5.1. Construction features

The fixed parts allow MV switchboards with metal enclosure to be built, suitable for indoor installation.

The fixed parts are pre-assembled and tested in the factory. The fixed parts are suitable for all primary distribution requirements with service voltages up to 24 kV and can take on different configurations according to customer requests.

The fixed parts allow arc-proof switchboards to be constructed in compliance with the prescriptions of the IEC 62271/200, Class of access (A) criteria (1 - 5). With the PB/F fixed parts it is possible to build switchgears with IP2X degree of protection with open door.

Each unit (fig. 6) is set up of:

- 1 Shutters
- 2 Lower and upper monoblocks
- 3 Earthing switch (on request)

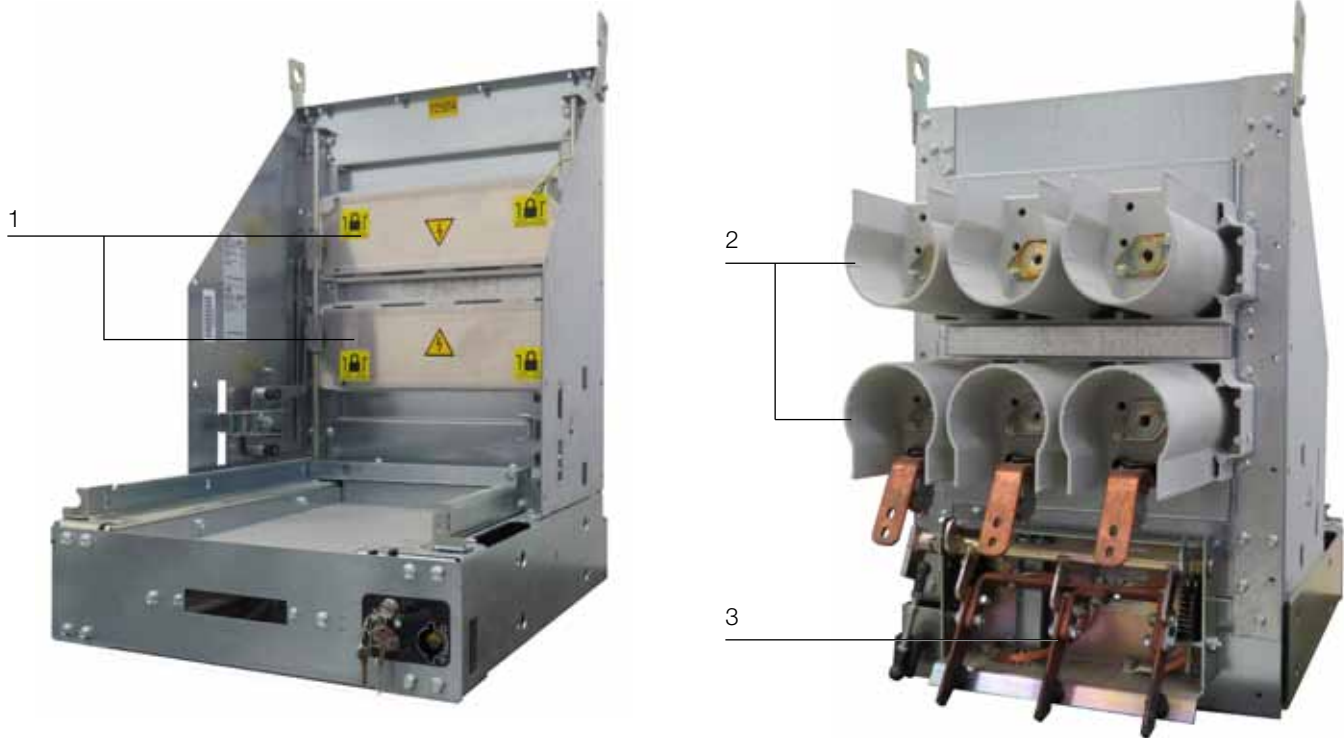

Fig. 6

5.2. Dimensions and weights

Types available

PowerCube PB1/F ... PB4/F and PB1/FL ... PB2/FL: suitable for incoming, outgoing and bus-tie units.

Un [kV]	In [kA]	Icw-Isc [A]	Width	Module
12	31,5	400	600 mm	PB1/F - PB1/FL
	31,5	630	600 mm	PB1/F - PB1/FL
	31,5	1250	600 mm	PB1/F - PB1/FL
	31,5	630	750 mm	PB2/F - PB2/FL
	31,5	1250	750 mm	PB2/F - PB2/FL
	31,5	1600	750 mm	PB2/F - PB2/FL
	31,5	2000	750 mm	PB2/F - PB2/FL
17	31,5	630	600 mm	PB1/F - PB2/FL
	31,5	1250	600 mm	PB1/F - PB2/FL
	31,5	630	750 mm	PB2/F - PB2/FL
	31,5	1250	750 mm	PB2/F - PB2/FL
	31,5	1600	750 mm	PB2/F - PB2/FL
	31,5	2000	750 mm	PB2/F - PB2/FL
24	25	630	750 mm	PB4/F
	25	1250	750 mm	PB4/F
12	40-50	1250	750 mm	PB2/F - PB2/FL
	40-50	1600	750 mm	PB2/F - PB2/FL
	40-50	2000	750 mm	PB2/F - PB2/FL
17	40-50	1250	750 mm	PB2/F - PB2/FL
	40-50	1600	750 mm	PB2/F - PB2/FL
	40-50	2000	750 mm	PB2/F - PB2/FL

Overall dimensions

PB1/F

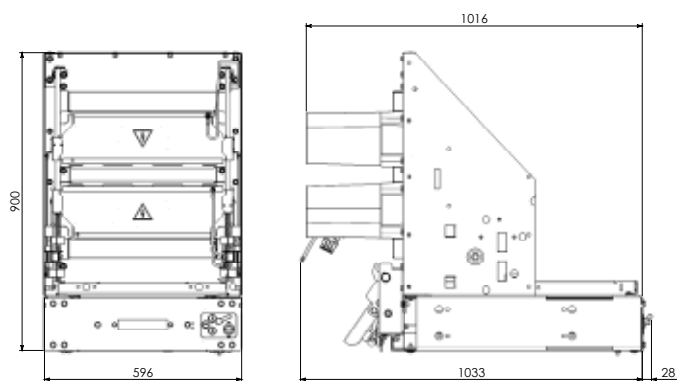

PB1/FL

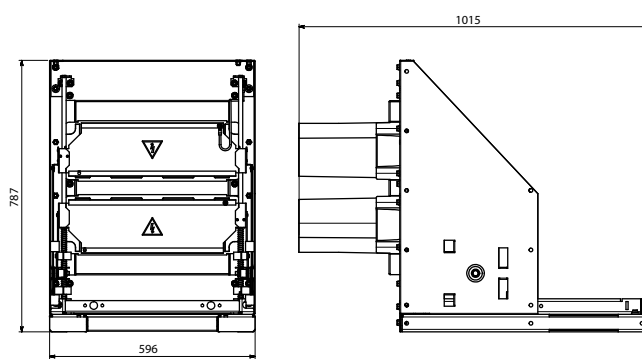

Dimensional drawings available on request in electronic format.

Unit PB1/F			
Un (kV)	Icw (kA)	In (A)	TN
12	31.5	630 - 1250	1VCD003382
17	31.5	630 - 1250	1VCD003382

Unit PB1/FL			
Un (kV)	Icw (kA)	In (A)	TN
12	31.5	630 - 1250	1VCD003614
17	31.5	630 - 1250	1VCD003614

Unit PB1/F - PB1/FL	Typical use
Contact diameter (mm)	35 mm
Rated voltage	12-17 kV
Test voltage at industrial frequency	28-38 kV
Impulse withstand voltage	75-95 kV bil
Short-time withstand current	31.5 kA x 3s
Peak current	79 kA
Rated branch current	630-1250 A

Earthing switch (if requested) only PB1/F

Short-time withstand current	31.5 kA x 3s
Peak current	79 kA

PB2/F

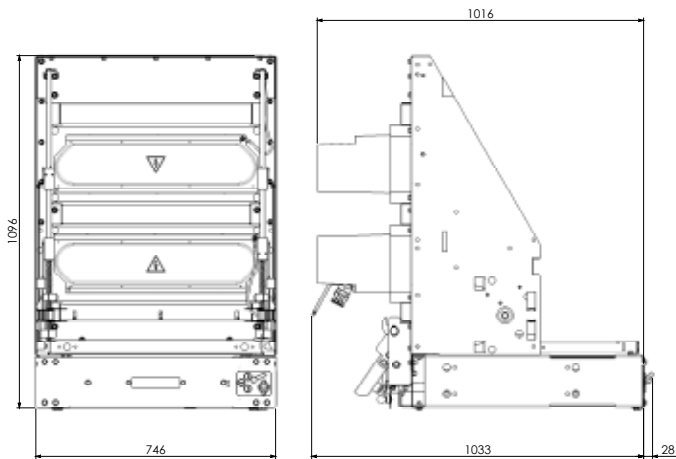

PB2/FL

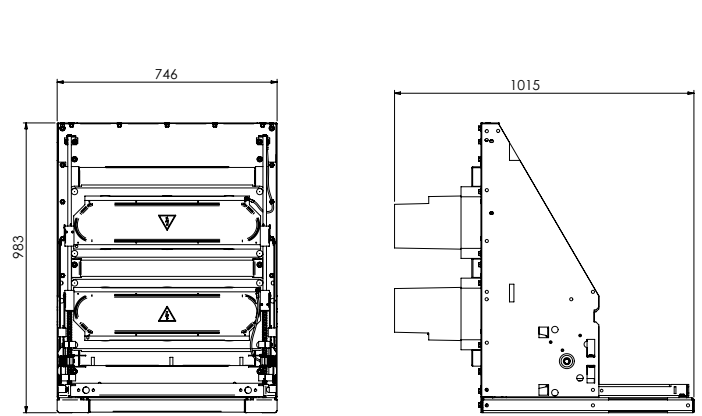

Dimensional drawings available on request in electronic format.

Unit PB2/F

Un (kV)	Icw (kA)	In (A)	TN
12	50	630...2000	1VCD003383
17	50	630...2000	1VCD003383

Unit PB2/FL

Un (kV)	Icw (kA)	In (A)	TN
12	50	630...2000	1VCD000210
17	50	630...2000	1VCD000210

Unit PB2/F - PB2/FL

	Typical use
Rated voltage	12 - 17 kV
Test voltage at industrial frequency	28 - 38 kV
Impulse withstand voltage	75 - 95 kV bil
Short-time withstand current	40 kA x 3s - 50 kA x 1s
Peak current	125 kA
Rated branch current	630 - 1250 A ⁽¹⁾ 1600 - 2000 A ⁽²⁾

Earthing switch (if requested) only PB1/F

Short-time withstand current	31,5 kA x 3s - 40÷50 kA x 1s
Peak current	79 kA

(1) Contact diameter 35 mm.

(2) Contact diameter 79 mm.

PB4/F

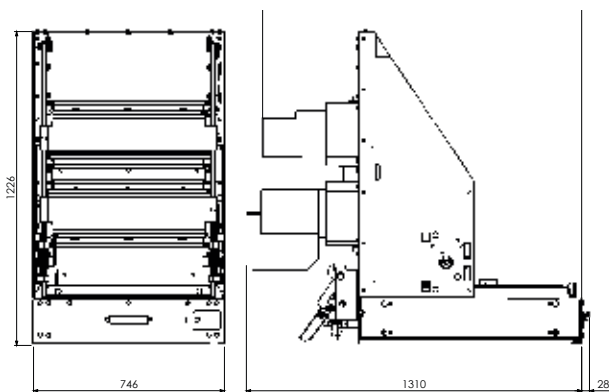

Dimensional drawings available on request in electronic format.

Un (kV)	Icw (kA)	In (A)	TN
24	31.5	630 - 1250	1VCD003384

Module PB4/F

	Typical use
Rated voltage	24 kV
Test voltage at industrial frequency	50 kV
Impulse withstand voltage	125 kV bil
Short-time withstand current	31.5 kA x 3s
Peak current	79 kA
Rated branch current	630-1250 A ⁽¹⁾

Earthing switch (if requested)

Short-time withstand current	31.5 kA x 3s
Peak current	79 kA

(1) Contact diameter 35 mm.

Fixed parts compatibility with ABB apparatus

Table 1 - VD4 withdrawable circuit-breakers (*)

Rated current of the circuit-breakers VD4 (A - 40 °C)



kV	Isc (kA)	Icw (kA)	W=600 p=150 u/l=205 H=260 ø=35	W=750 p=210 u/l=310 H=280 ø=35	W=750 p=210 u/l=310 H=280 ø=79	W=750 p=210 u/l=310 H=325 ø=35	Circuit-breaker	PowerCube
12 - 17,5	16	16	630				VD4/P 12.06.16 p150	VD4/P 17.06.16 p150
	20	20	630				VD4/P 12.06.20 p150	VD4/P 17.06.20 p150
	25	25	630				VD4/P 12.06.25 p150	VD4/P 17.06.25 p150
	31.5	31.5	630				VD4/P 12.06.32 p150	VD4/P 17.06.32 p150
	16	16	1250				VD4/P 12.12.16 p150	VD4/P 17.12.16 p150
	20	20	1250				VD4/P 12.12.20 p150	VD4/P 17.12.20 p150
	25	25	1250				VD4/P 12.12.25 p150	VD4/P 17.12.25 p150
	31.5	31.5	1250				VD4/P 12.12.32 p150	VD4/P 17.12.32 p150
	16	16		630			VD4/W 12.06.16 p210	VD4/W 17.06.16 p210
	20	20		630			VD4/W 12.06.20 p210	VD4/W 17.06.20 p210
	25	25		630			VD4/W 12.06.25 p210	VD4/W 17.06.25 p210
	31.5	31.5		630			VD4/W 12.06.32 p210	VD4/W 17.06.32 p210
	16	16		1250			VD4/W 12.12.16 p210	VD4/W 17.12.16 p210
	20	20		1250			VD4/W 12.12.20 p210	VD4/W 17.12.20 p210
25	25		1250			VD4/W 12.12.25 p210	VD4/W 17.12.25 p210	
31.5	31.5		1250			VD4/W 12.12.32 p210	VD4/W 17.12.32 p210	
40	40		1250			VD4/W 12.12.40 p210	VD4/W 17.12.40 p210	
50	50		1250			-	-	
40	40			1250		VD4/P 12.12.40 p210	VD4/P 17.12.40 p210	
50	50			1250		VD4/P 12.12.50 p210	VD4/P 17.12.50 p210	
20	20			1600		VD4/P 12.16.20 p210	VD4/P 17.16.20 p210	
25	25			1600		VD4/P 12.16.25 p210	VD4/P 17.16.25 p210	
31.5	31.5			1600		VD4/P 12.16.32 p210	VD4/P 17.16.32 p210	
40	40			1600		VD4/P 12.16.40 p210	VD4/P 17.16.40 p210	
50	50			1600		VD4/P 12.16.50 p210	VD4/P 17.16.50 p210	
20	20			2000		VD4/P 12.20.20 p210	VD4/P 17.20.20 p210	
25	25			2000		VD4/P 12.20.25 p210	VD4/P 17.20.25 p210	
31.5	31.5			2000		VD4/P 12.20.32 p210	VD4/P 17.20.32 p210	
40	40			2000		VD4/P 12.20.40 p210	VD4/P 17.20.40 p210	
50	50			2000		VD4/P 12.20.50 p210	VD4/P 17.20.50 p210	
24	16	16				630	VD4/P 24.06.16 p210	-
	20	20				630	VD4/P 24.06.20 p210	-
	25	25				630	VD4/P 24.06.25 p210	-
	16	16				1250	VD4/P 24.12.16 p210	-
	20	20				1250	VD4/P 24.12.20 p210	-
	25	25				1250	VD4/P 24.12.25 p210	-
	31.5	31.5				1250	VD4/P 24.12.32 p210	-

W = Width of PowerCube module.

P = Horizontal centre distance between circuit-breaker poles.

U/L = Distance between top and bottom terminal.

H = Distance between bottom terminal and earth

Ø = Diameter of the contacts in the PowerCube module monobloc.

(*) The fixed parts are not prepared for application of the "motorised truck".

Table 2 - Withdrawable HD4 circuit-breakers

Rated current of the circuit-breakers HD4 (A - 40 °C)



kV	Isc (kA)	Icw (kAx3s)	W=600 p=150 u/l=205 H=260 ø=35	W=750 p=210 u/l=310 H=280 ø=35	W=750 p=210 u/l=310 H=280 ø=79	W=750 p=210 u/l=310 H=325 ø=35	Circuit-breaker	PowerCube
12 - 17,5	16	16	630				HD4/W 12.06.16 p150	HD4/W 17.06.16 p150
	25	25	630				HD4/W 12.06.25 p150	HD4/W 17.06.25 p150
	31.5	31.5	630				HD4/W 12.06.32 p150	HD4/W 17.06.32 p150
	16	16	1250				HD4/W 12.12.16 p150	HD4/W 17.12.16 p150
	25	25	1250				HD4/W 12.12.25 p150	HD4/W 17.12.25 p150
	31.5	31.5	1250				HD4/W 12.12.32 p150	HD4/W 17.12.32 p150
	16	16		630			HD4/W 12.06.16 p210	HD4/W 17.06.16 p210
	25	25		630			HD4/W 12.06.25 p210	HD4/W 17.06.25 p210
	31.5	31.5		630			HD4/W 12.06.32 p210	HD4/W 17.06.32 p210
	16	16		1250			HD4/W 12.12.16 p210	HD4/W 17.12.16 p210
	25	25		1250			HD4/W 12.12.25 p210	HD4/W 17.12.25 p210
	31.5	31.5		1250			HD4/W 12.12.32 p210	HD4/W 17.12.32 p210
12 - 17,5	40	40		1250			HD4/W 12.12.40 p210	HD4/W 17.12.40 p210
	50	50		1250			HD4/W 12.12.50 p210	HD4/W 17.12.50 p210
	16	16			1600		HD4/W 12.16.16 p210	HD4/W 17.16.16 p210
	25	25			1600		HD4/W 12.16.25 p210	HD4/W 17.16.25 p210
	31.5	31.5			1600		HD4/W 12.16.32 p210	HD4/W 17.16.32 p210
	40	40			1600		HD4/P 12.16.40 p210	HD4/P 17.16.40 p210
	50	50			1600		HD4/P 12.16.50 p210	HD4/P 17.16.50 p210
	16	16			2000		HD4/W 12.20.16 p210	HD4/W 17.20.16 p210
	25	25			2000		HD4/W 12.20.25 p210	HD4/W 17.20.25 p210
	31.5	31.5			2000		HD4/W 12.20.32 p210	HD4/W 17.20.32 p210
	40	40			2000		HD4/P 12.20.40 p210	HD4/P 17.20.40 p210
	50	50			2000		HD4/P 12.20.50 p210	HD4/P 17.20.50 p210
24	16	16				630	HD4/W 24.06.16 p210	--
	20	20				630	HD4/W 24.06.20 p210	--
	25	25				630	HD4/W 24.06.25 p210	--
	16	16				1250	HD4/W 24.12.16 p210	--
	20	20				1250	HD4/W 24.12.20 p210	--
	25	25				1250	HD4/W 24.12.25 p210	--
	31.5	31.5				1250	HD4/P 24.12.32 p210	--

W = Width of PowerCube module.

P = Horizontal centre distance between circuit-breaker poles.

U/L = Distance between top and bottom terminal.

H = Distance between bottom terminal and earth

Ø = Diameter of the contacts in the PowerCube module monobloc.

Table 3 - Withdrawable VM1 circuit-breakers (*)
Rated current of the circuit-breakers VM1 (A - 40 °C)



kV	Isc (kA)	Icw (kAx3s)	W=600 p=150 u/l=205 H=260 ø=35	W=750 p=210 u/l=310 H=280 ø=35	W=750 p=210 u/l=310 H=280 ø=79	W=750 p=210 u/l=310 H=325 ø=35	Circuit-breaker	PowerCube
12-17.5 (*)	16	16	630				VM1/P 12.06.16 p150	VM1/P 17.06.16 p150
	20	20	630				VM1/P 12.06.20 p150	VM1/P 17.06.20 p150
	25	25	630				VM1/P 12.06.25 p150	VM1/P 17.06.25 p150
	31.5	31.5	630				VM1/P 12.06.32 p150	VM1/P 17.06.32 p150
	16	16	1250				VM1/P 12.12.16 p150	VM1/P 17.12.16 p150
	20	20	1250				VM1/P 12.12.20 p150	VM1/P 17.12.20 p150
	25	25	1250				VM1/P 12.12.25 p150	VM1/P 17.12.25 p150
	31.5	31.5	1250				VM1/P 12.12.32 p150	VM1/P 17.12.32 p150
	16	16		630			VM1/W 12.06.16 p210	VM1/W 17.06.16 p210
	20	20		630			VM1/W 12.06.20 p210	VM1/W 17.06.20 p210
	25	25		630			VM1/W 12.06.25 p210	VM1/W 17.06.25 p210
	31.5	31.5		630			VM1/W 12.06.32 p210	VM1/W 17.06.32 p210
	16	16		1250			VM1/W 12.12.16 p210	VM1/W 17.12.16 p210
	20	20		1250			VM1/W 12.12.20 p210	VM1/W 17.12.20 p210
	25	25		1250			VM1/W 12.12.25 p210	VM1/W 17.12.25 p210
	31.5	31.5		1250			VM1/W 12.12.32 p210	VM1/W 17.12.32 p210
24 (*)	20	20			1600		VM1/P 12.16.20 p210	VM1/P 17.16.20 p210
	25	25			1600		VM1/P 12.16.25 p210	VM1/P 17.16.25 p210
	31.5	31.5			1600		VM1/P 12.16.32 p210	VM1/P 17.16.32 p210
	20	20			2000		VM1/P 12.20.20 p210	VM1/P 17.20.20 p210
	25	25			2000		VM1/P 12.20.25 p210	VM1/P 17.20.25 p210
	31.5	31.5			2000		VM1/P 12.20.32 p210	VM1/P 17.20.32 p210
	16	16				630	VM1/P 24.06.16 p210	
20	20				630	VM1/P 24.06.20 p210		
25	25				630	VM1/P 24.06.25 p210		
PB4/F	16	16				1250	VM1/P 24.12.16 p210	
	20	20				1250	VM1/P 24.12.20 p210	
	25	25				1250	VM1/P 24.12.25 p210	

W = Width of PowerCube module.

P = Horizontal centre distance between circuit-breaker poles.

U/L = Distance between top and bottom terminal.

H = Distance between bottom terminal and earth.

Ø = Diameter of the contacts in the PowerCube module monobloc.

(*) The fixed part are not prepared for application of the "motorised truck".

Table 3.a - Withdrawable VM1/A/P (ANSI) circuit-breakers

Rated current of the VM1/A/P contactors (A - 40 °C)



kV	Isc (kA)	Icw (kAx3s)	Rated current of the apparatus racked into the fixed part				Circuit-breaker	PowerCube (IEC-compatible version)
			W=600 p=150 u/l=205 H=260 ø=35	W=750 p=210 u/l=310 H=280 ø=35	W=750 p=210 u/l=310 H=280 ø=79	W=750 p=210 u/l=310 H=325 ø=35		
15	25	25	1200				VM1/A/P 15.12.25 p150	PB1/FL
	31,5	31,5	1200				VM1/A/P 15.12.32 p150	
	25	25		1200			VM1/A/W 15.12.25 p210	PB2/FL
	31,5	31,5		1200			VM1/A/W 15.12.32 p210	
	25	25			2000		VM1/A/P 15.20.25 p210	
	31,5	31,5			2000		VM1/A/P 15.20.32 p210	

Table 4 - Withdrawable Vmax circuit-breakers



kV	Isc (kA)	Icw (kAx3s)	Rated current of the apparatus racked into the fixed part				Apparatus which can be combined with the fixed part		PowerCube
			W=600 p=150 u/l=205 H=260 ø=35	W=750 p=210 u/l=310 H=280 ø=35	W=750 p=210 u/l=310 H=280 ø=79	W=750 p=210 u/l=310 H=325 ø=35	Type of apparatus		
12-17.5	16	16	630				Vmax/W 12.06.16 p150	Vmax/W 17.06.16 p150 *	PB1/F PB1/FL
	20	20	630				Vmax/W 12.06.20 p150	Vmax/W 17.06.20 p150 *	
	25	25	630				Vmax/W 12.06.25 p150	Vmax/W 17.06.25 p150 *	
	31.5	31.5	630				Vmax/W 12.06.32 p150	Vmax/W 17.06.32 p150 *	
	16	16	1250				Vmax/W 12.12.16 p150	Vmax/W 17.12.16 p150 *	
	20	20	1250				Vmax/W 12.12.20 p150	Vmax/W 17.12.20 p150 *	
	25	25	1250				Vmax/W 12.12.25 p150	Vmax/W 17.12.25 p150 *	
	31.5	31.5	1250				Vmax/W 12.12.32 p150	Vmax/W 17.12.32 p150 *	

W = Width of fixed part
P = Horizontal centre distance between circuit-breaker poles.
u/l = Distance between top and bottom terminal.
H = Distance between bottom terminal and earth.
Ø = Diameter of the contacts in the PB type PowerCube unit monobloc.
* = For availability ask ABB.

Table 5 - Withdrawable V-Contact contactors
Rated current of the V-Contact contactors (A - 40 °C)



kV	Isc (kA) (1)	Icw (kAx1s)	W=600 p=150 u/l=205 H=260 ø=35	Contactor	PowerCube
7,2	16	6	400 (2)	VSC7/P	PB1/F PB1/FL
	20	6	400 (2)		
	25	6	400 (2)		
	31.5	6	400 (2)		
12	16	6	400 (2)	VSC12/P	PB1/F PB1/FL
	20	6	400 (2)		
	25	6	400 (2)		
	31.5	6	400 (2)		

(1) Guaranteed using suitable fuses.

(2) The rated current is subject to derating according to the rated current of the fuses.

5.3. Main components

5.3.1. Switchgear

PowerCube modules can be equipped with the following switchgear:

- HD4 series SF6 circuit-breaker;
- VD4, VM1, eVD4 e Vmax series vacuum circuit-breaker;
- V-Contact VSC series vacuum contactor;
- operational trucks.

The apparatus is always the withdrawable version, mounted on a truck that allows the following positions in relation to the compartment:

- CONNECTED:** – main circuits connected;
- ISOLATED:** – partially isolated with main circuits disconnected;
- totally isolated with main circuits disconnected;
- WITHDRAWN:** – main circuits disconnected and apparatus racked out.

The apparatus is equipped with special locks, located on the front crosspiece which allow their hooking into the corresponding slots of the unit. The front hooking crosspiece also allows the connecting/isolating operation, with the door closed, by means of the special operating lever. A lock prevents truck insertion (for example when the earthing switch is closed).

If the truck is in the indefinite position (between connected and isolated), the lock prevents both mechanical and electrical circuit-breaker closing.

The truck can be equipped with a locking magnet which, if deenergised, prevents its operation.

The connector (plug) for connection of the operating mechanism electrical accessories comes out of the front protection of the apparatus.

The slides for activating the segregation shutters of the medium voltage contacts are placed on the sides of the apparatus.

Please refer to the relative instruction booklet for further details.

5.3.2. Earthing switch

The earthing switch (1) (fig. 7) with making capacity is placed in the fixed part rear side, whereas the front houses the operating mechanism (2).

The switch position is indicated in the flange of the operating seat (2). The switch position is indicated in the flange of the operating seat (2).



The certain position of the earthing switch is indicated by the graphic symbols at the operating seat (2). The position of the earthing switch is indicated by the yellow arrow made directly on the operating shaft (5).

The position of the earthing switch can be checked either by means of the indicator (3), located inside the enclosure and visible through the inspection window (4) positioned on the bottom front part of the unit.

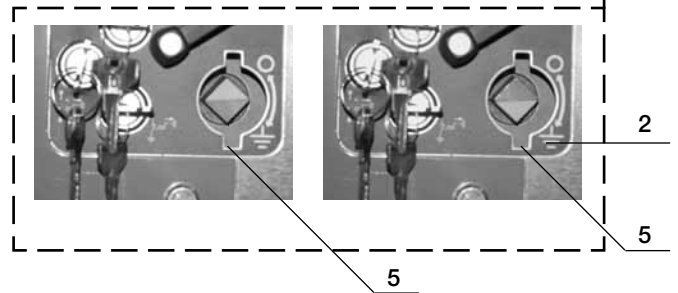
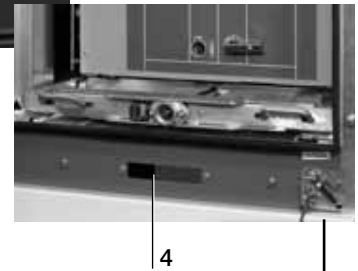
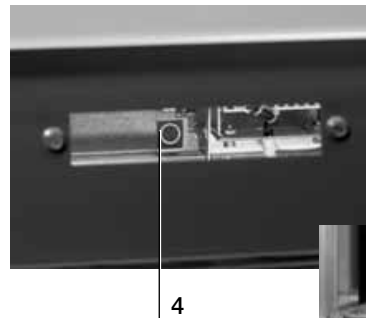
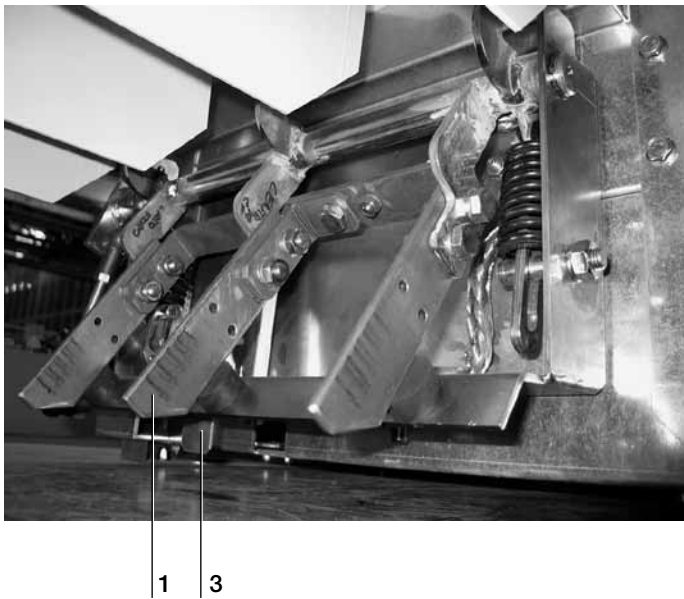

Fig. 7

5.3.3. Fixed part description

The metal structure is fitted with operating and control mechanisms on the external front side (fig. 8).

The earthing switch control panel on the lower front part is fitted with:

- the earthing switch operating mechanism seat (10);
- the actuator (9) for operating the shutter (11) of the earthing switch operating mechanism seat;
- key lock with earthing switch open (8);
- key lock with earthing switch closed (12);
- key lock for preventing apparatus racking in (7).

The fixed part houses the following components:

- truck guides (15);
- segregating shutters (18) of the fixed isolating contacts inside the monoblocks and the shutter operating mechanisms (16);
- mechanical lock for preventing either circuit-breaker racking in when the earthing switch is closed or earthing switch closing if the circuit-breaker is connected (27);

The insulating monoblocks (14) for the power connections are on the rear of the fixed part.

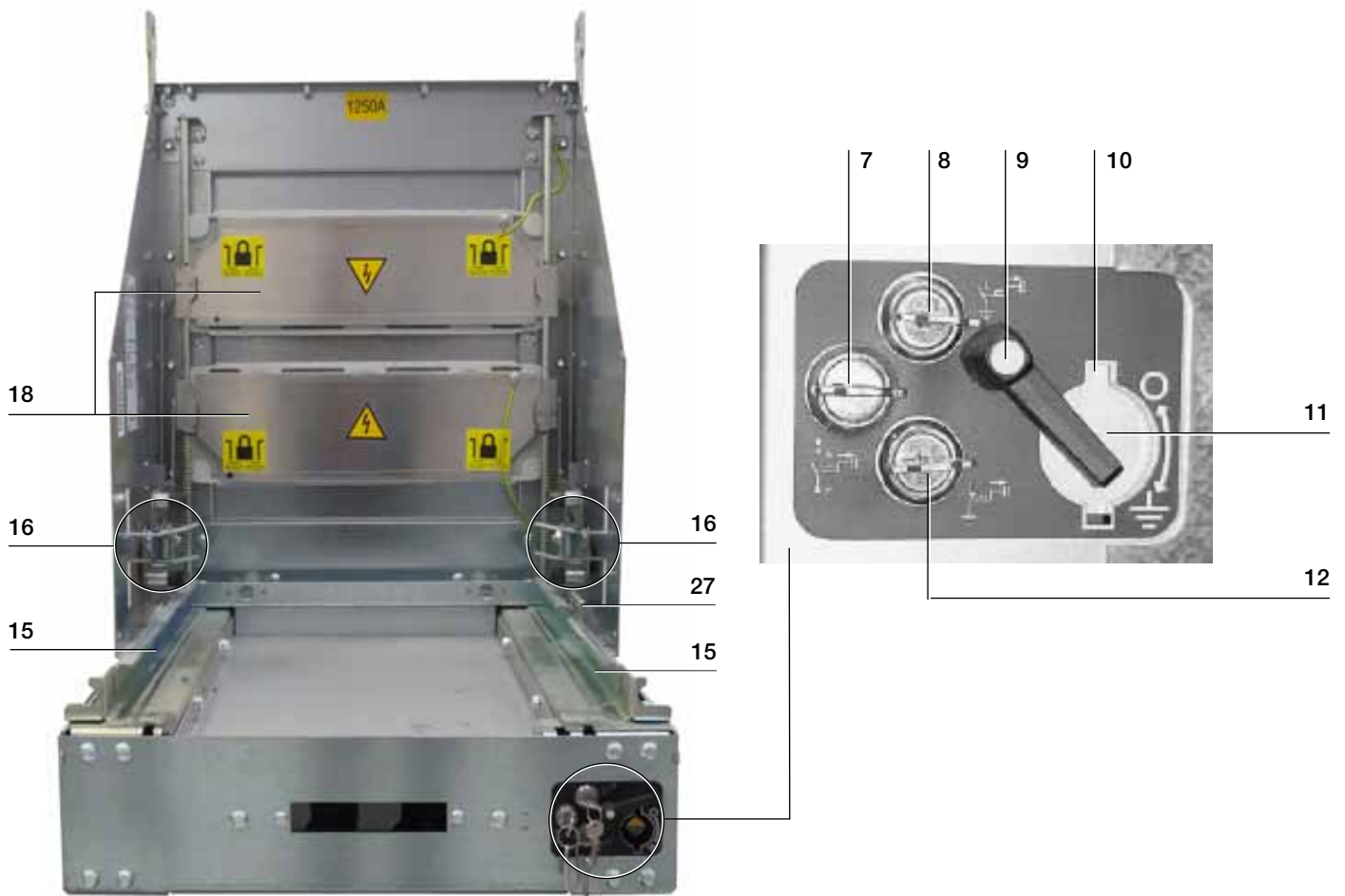

Fig. 8

5.4. Interlocks/locks



- **The operations must be carried out using normal operating force (not more than 200 N) only using the special levers.**
Should the operations be prevented, do not force the mechanical interlocks and check that the operations are correct.
- **The locks can be activated with a maximum force of 400 N, using the special operating tools.**

The locks used in the fixed parts are mechanical and electrical with microswitches for circuit continuity or interruption.

The mechanical locks are divided into:

- force locks;
- prevention locks;
- electromechanical locks;
- safety locks (padlocks/keys).

PowerCube modules can be equipped with the locks shown in the following table.

Lock description	Apparatus	Fixed part
Electric lock to prevent apparatus closing when the truck is not in the connected/isolated position.	● (fig. 10c - det. 44)	
Mechanical lock to prevent apparatus racking in/out in the closed position, and closing when the truck is not in the connected and isolated positions.	●	
Locking electromagnet on the apparatus truck to prevent racking-in/out without power.	● (fig. 10c - det. 43)	
Mechanical interlock with earthing switch: – the apparatus cannot be inserted when the earthing switch is closed; – the earthing switch cannot be closed when the apparatus is inserted or in the intermediate positions between connected and isolated.	● (fig. 10a - det. 12) ●	● (fig. 9 - det. 1) ●
Mechanical lock to prevent the manual opening of the shutters when the apparatus is withdrawn (Fail-Safe).	○ (fig. 10b - det. 3)	○ (fig. 9 - det. 2)
Key lock to prevent apparatus insertion. Only when the apparatus is in the isolated position can the lock be operated and the key released thus preventing apparatus insertion.	●	○ (fig. 9a - det. 3)
Key lock with open earthing switch. It can only be operated when the earthing switch is open. The key can only be withdrawn with the lock activated.		○ (fig. 9a - det. 4)
Key lock with closed earthing switch. It can only be operated when the apparatus is isolated and the earthing switch is closed. The key can only be removed with the lock activated.		○ (fig. 9a - det. 5)
Holes for padlock of the shutters in the closed position (Padlock diameter 4mm).		○ (fig. 9a - det. 6)
Earthing switch electromechanical lock to prevent earthing switch opening and closing once the coil (BED) is de-energised.		○ (fig. 9a - det. 7)
Padlock lock to prevent manual apparatus closing.	●	

- Standard
- On request.

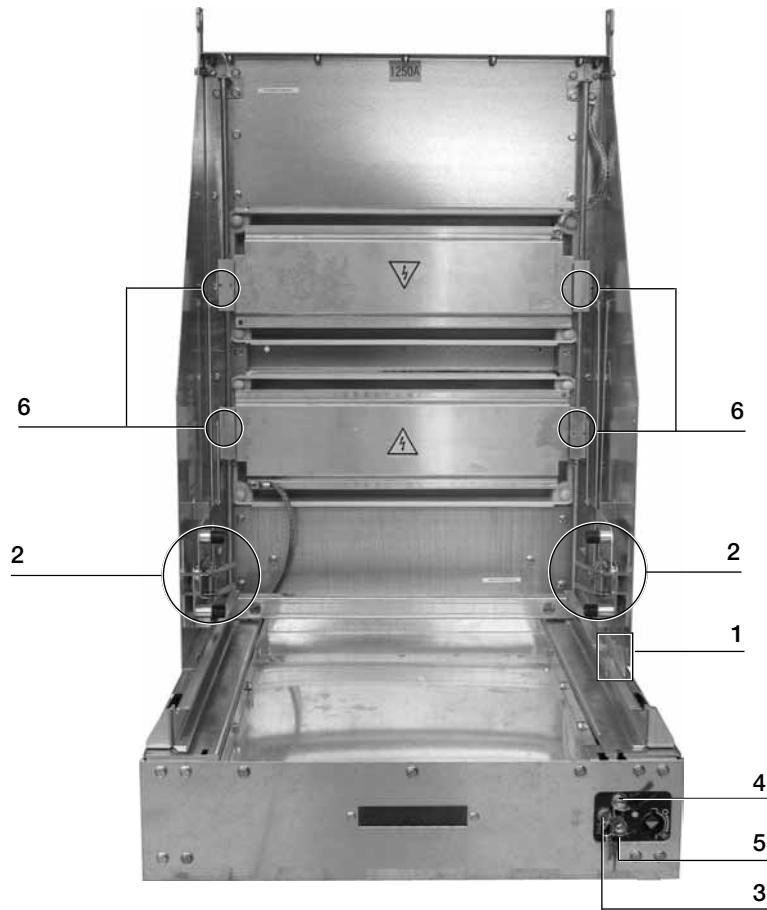

Fig. 9

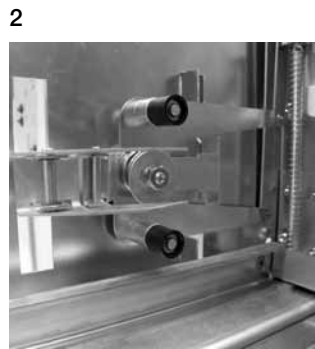

Fig. 9a



Fig. 9b

Apparatus locks

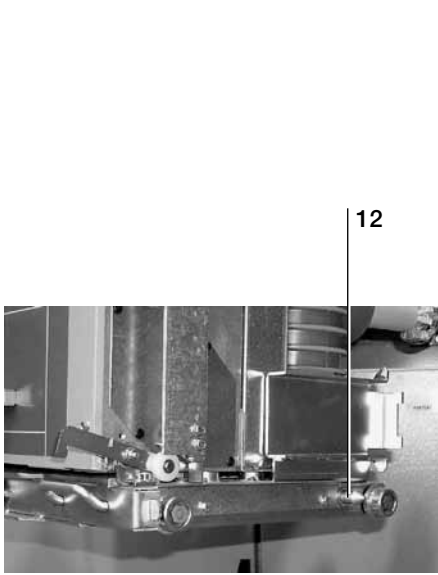

Fig. 10a

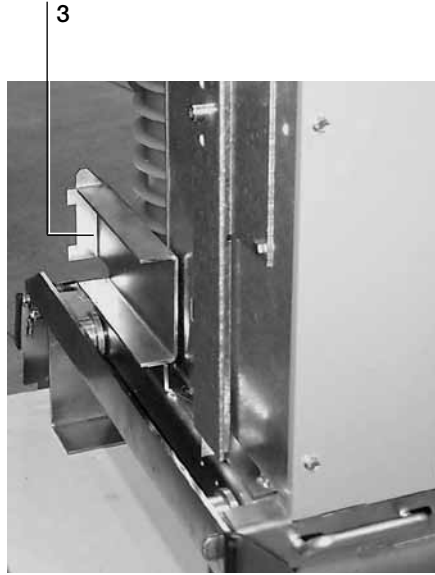

Fig. 10b

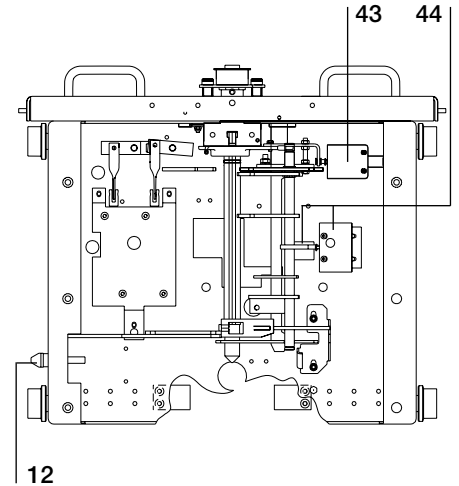

Fig. 10c

Coding the plug-socket connector of the auxiliary circuits

Coding the plug-socket connector of the auxiliary circuits allows the apparatus to be electrically combined with its panel. For example, it only allows apparatus with different rated current or particular cabling circuits to be combined with the panels they are destined for.

The operating mechanism cabling coding pins are inserted in the sockets, and must couple with the corresponding seats of the plug-socket connector.

Coding the plug-socket connector depends on the final configuration of the switchgear and must be carried out by the customer by closing the holes not used with the special plugs, according to the coding enclosed with this manual.

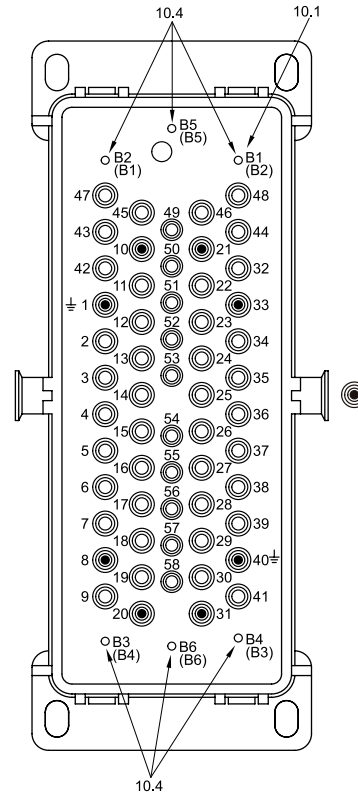

Socket references:
B1 - B2 - B3 - B4 - B5 - B6.

Plug references:
(B1) - (B2) - (B3) - (B4) - (B5) - (B6).

Fig. 11

Application of locks on plug-socket

Ir	Apparatus	Pole center line	Isc	Ø contacts	B1	B2	B3	B4	B5	B6				
400A	V-CONTACT VSC	150	31,5 kA	35							← Pin position in the plug (apparatus)			
630A	HD4-VD4-VM1													
1250A	HD4-VD4-VM1													
1250A	HD4 isolating truck	210	31,5 kA	35							← Hole position in the socket (switchgear)			
1250A	HD4-VD4-VM1													
1250A	VD4/W													
1250A	HD4 (UniSafe/PowerCube)													
1250A	VD4/P					50 kA	79							
1250A	HD4 isolating truck													
1600A	HD4-VD4-VM1					31,5-50 kA	79							
2000A	HD4-VD4-VM1													
1250A	HD4 isolating truck													
The white boxes in the correspond with the assembly position of the rivets on the switchgear side socket.					B2	B1	B4	B3	B5	B6	←			

5.6. Reference Standards

IEC 62271-1	for general application
IEC 62271-200	for the switchgear
IEC 62271-102	for the earthing switch
IEC 60071-2	coordination of insulation
IEC 62271-100	for the circuit-breakers
IEC 62271-106	for the contactor
IEC 60265-1	for the switch-disconnector
CEI EN 60529	degrees of protection for the housings Classification.
CEI EN 60447	Human-machine interaction. Operating principles.

6. Instructions for operating the apparatus and operation sequence of the units



- Do not remove the circuit-breaker covering panels; if necessary, keep a safe distance during apparatus opening and closing operations to avoid any contact with moving parts.
- The operations must be carried out with normal activating force (not more than 260 Nm), only using the special tools (see para. 6.1). Should they be prevented, make sure that the operating sequence is correct.

6.1. Operating accessories and devices

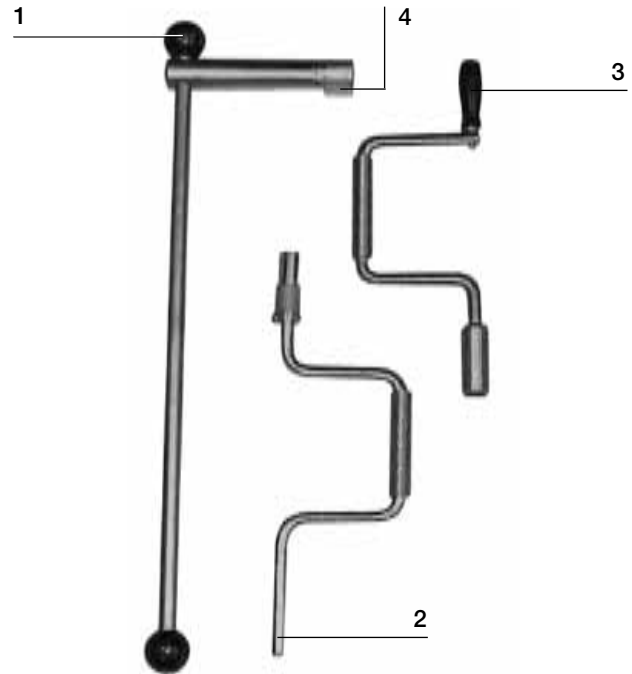

Caption

- 1 Earthing switch operating lever
- 2 Circuit-breaker charging-spring lever
- 3 Circuit-breaker racking in/out lever
- 4 Operating lever raised part

Fig. 12

6.2. Apparatus racking in/out



- Should any operation be carried out while the circuit-breaker is withdrawn from the switchboard, pay the utmost attention to the moving parts.
- The circuit-breaker must be inserted into the unit only in the open position; its racking in/out must be gradual, so as to safeguard the mechanical interlocks against any deforming impact.

6.2.1. Apparatus (circuit-breakers and contactors)

The following instructions refer to HD4 circuit-breakers but they are valid for VD4 circuit-breakers and V-Contact contactors as well.

a) Racking in

- (1) Switching from circuit-breaker withdrawn to “isolated” position
 - place the circuit-breaker handles towards the back of the module until the circuit-breaker locks with the handles (5) (fig. 13b) clicking laterally, inserting themselves into the slots;
 - unlock the wheels (3) (fig. 13a), lift the hooking bracket and remove the truck from the switchboard.



Make sure that the handles have tripped sideways (horizontal locks of the truck inserted in the enclosure)

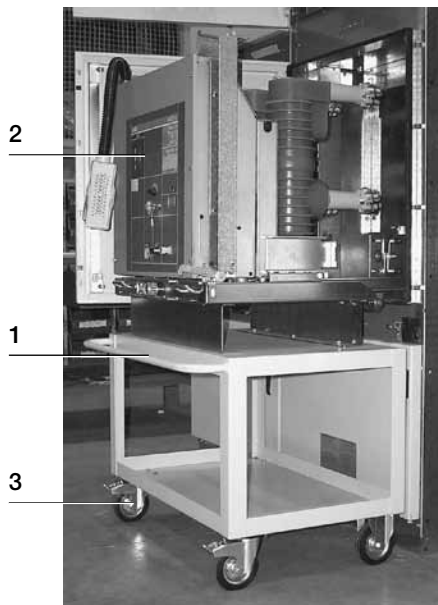

Fig. 13a

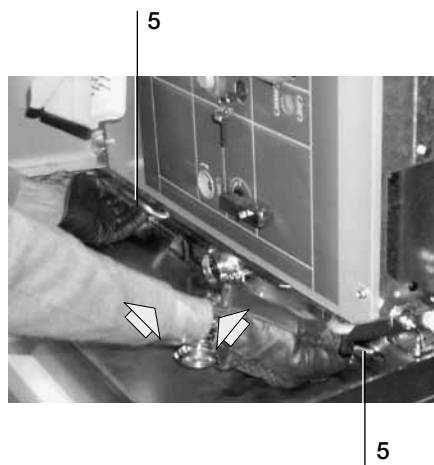

Fig. 13b

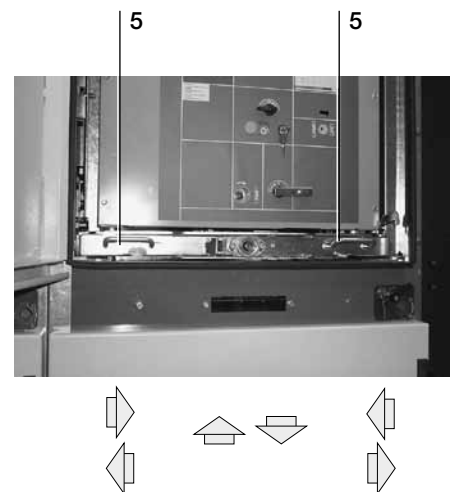
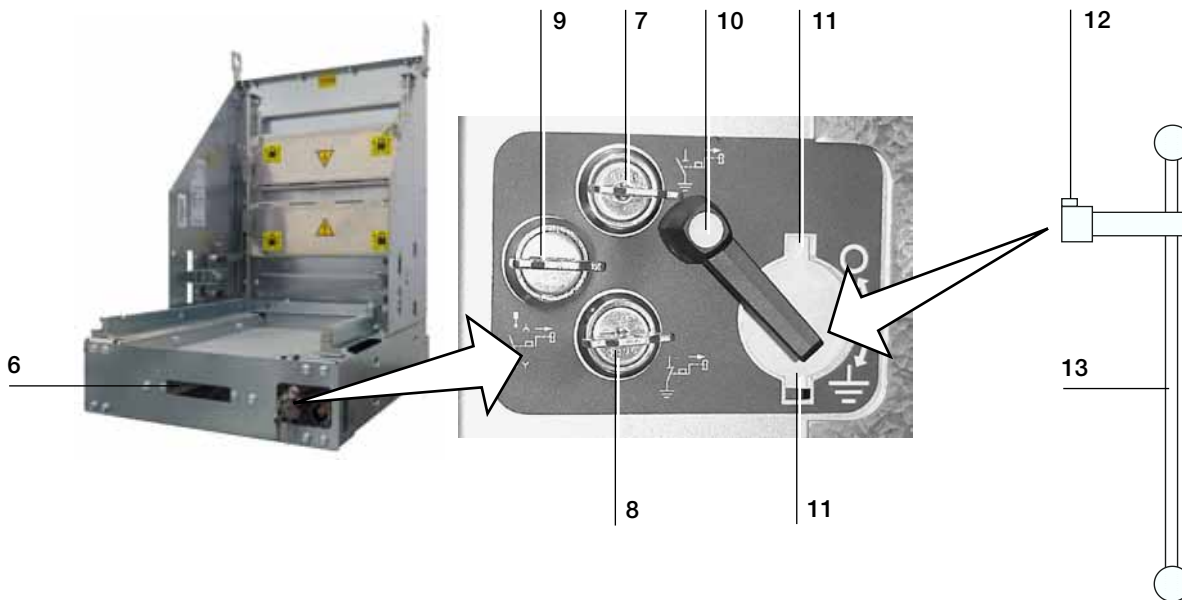

Fig. 13c

- (2) Switching from “test” to “connected” position (with earthing switch closed) (fig. 14)
- make sure that:
 - the locking electromagnet of the earthing switch is energised (if supplied);
 - the key locks (7-8-9) are de-energised, if supplied;
 - insert operating lever (13) into the seat of the earthing switch making the raised piece (12) coincide with one of the two slots (11);
 - open the earthing switch, turning the operating lever anticlockwise (13);
 - withdraw the operating lever (13) from the earthing switch seat;
 - through the inspection window (6) make sure that the earthing switch is open (indicator in the “O” position);
 - close the cover of the earthing switch seat by turning the actuator (10) clockwise; this operation unlocks the circuit-breaker and trips a lock for preventing insertion of the operating lever into the earthing switch;
 - make sure that the locking electromagnet on the circuit-breaker truck (if supplied) is energised and check that the key lock for preventing insertion (if supplied) is de-energised;
 - fully insert the operating lever of the circuit-breaker truck (3) (fig. 12) in the relevant coupling and turn it clockwise until the circuit-breaker is fully connected.

b) Racking out operation (only with circuit-breaker open)

- (1) Switching from “connected” to “isolated” position (with circuit-breaker open) (fig. 14)
- make sure that the earthing switch is open (indicator in the “O” position);
 - fully insert the circuit-breaker truck/racking in/out lever (3) (fig. 12) and turn it anticlockwise until the circuit-breaker stops;
 - open the cover of the earthing switch operating seat by turning the actuator anticlockwise (10);
 - insert the operating lever (13) in the earthing switch seat making the raised part (12) coincide with one of the two slots (11);
 - close the earthing switch turning the operating lever clockwise;
 - withdraw the operating lever (13) from the earthing switch seat;
 - through the inspection window (6 - fig. 14) and the operating seat (2 - fig. 7) make sure that the earthing switch position indicator is in the “I” position showing closing.
- (2) Switching from “isolated” to “withdrawn” position
- move the two handles (5) (fig. 13b) at the same time towards the circuit-breaker centre and by means of the handles gradually pull the circuit-breaker outside on the truck.



Caption of the earthing switch key locks
 7 lock with earthing switch open
 8 lock with earthing switch closed
 9 lock for preventing circuit-breaker insertion.

Fig. 14

6.2.2. Earthing switch



- **Make sure that the earthing switch key locks (if supplied) are disabled and that the electromagnetic lock of the earthing switch (if supplied) is energised.**
- **The earthing switch can only be operated with the circuit-breaker in the isolated or withdrawn position.**
- **Once started, the operations must be completed.**

Closing (fig. 14)

- Make sure that the circuit-breaker is either in the isolated or withdrawn position;
- open the cover of the earthing switch operating seat by turning the operating actuator (10) anticlockwise; the earthing switch operating seat is freed;
- insert the operating lever (13) in the earthing switch seat making the raised part (12) coincide with one of the two slots (11);
- close the earthing switch by turning (13) the lever clockwise;
- remove the operating lever;
- check on the operating seat (5) (fig. 7) and through the inspection window (6 - fig. 14) that the earthing switch is closed (indicator in the “ \perp ” position).

Opening (fig.14)

- Insert the operating lever (13) in the earthing switch seat making the raised part (12) coincide with one of the two slots (11);
- open the earthing switch turning the operating lever anticlockwise (13);
- remove the operating lever (13) from the earthing switch seat;
- through the operation seat (5) (fig. 7) and the inspection window (6 - fig. 14) make sure that the earthing switch is open (indicator in the “O” position);
- close the cover of the earthing switch turning the actuator (10) clockwise; the circuit-breaker is thus unlocked while a lock for preventing operating lever insertion into the earthing switch is activated.

7. Installation

7.1. General information



- Correct installation is of paramount importance. The instructions given by the manufacturer must be thoroughly studied and followed.
- Installation must be carried out by skilled personnel with in-depth knowledge of the apparatus.
- It is advisable to wear gloves for handling the components.
- The PB/F fixed part must be considered a component for building switchgears. The fixed part cannot be used or commissioned as loose component.

7.2. Normal installation room conditions

Maximum air temperature	+ 40 °C
Minimum air temperature	- 5 °C
Relative humidity	% ≤ 95
Altitude	≤ 1000

For other installation room characteristics, please refer to the product standards (IEC 60694).

For any special conditions, please contact us.

7.3. Tightening torque values for main busbars and earthing connection

In the fixed part, main busbar connections to terminals of monoblock and earthing busbar connection must be carried out according to the tightening torque values of the following table.

Nut or screw	Tightening torque (Nm)		Key for exagonal nut or screw
	Iron 4.8	Iron 8.8	
M3	0.5	1.2	5.5
M4	1.1	2.7	7
M5	2	5	8
M6	3.7	9	10
M8	9	22	13
M10	18	45	17
M12	30	75	19
M16	75	185	24
M18	104	260	27
M20	148	370	30

7.4. Connection of the lower terminals for units with earthing switch (with and without CT)



The PowerCube units are preset for connection of the CTs between the A and C contacts of the lower terminals.

If this is not done, connect contacts A and C to each other using a conductor with the same cross-section as the one in detail C.

In both cases, the connection must be made - by the customer - respecting the geometry indicated in the figure so that the making capacity of the earthing switch is guaranteed.

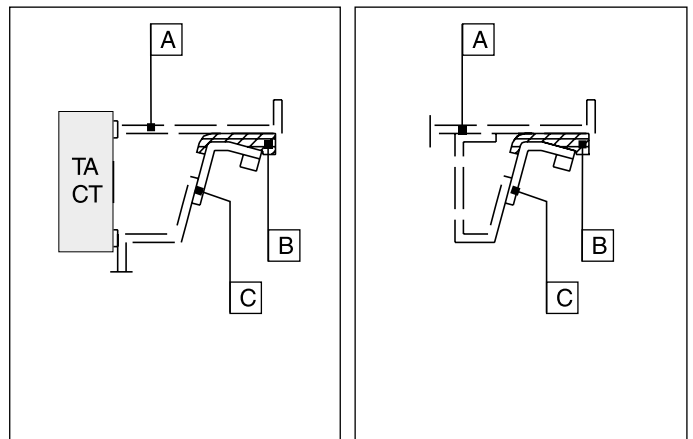

Caption

A = Lower terminal

B = Insulating support

C = Fixed contact

Fig. 15

8. Putting into service

8.1. Measurements and tests

Carry out the tests indicated below only after performing the preliminary operations.



- Check the switchgear are not energized (M.V. circuit)
- The check is only successful if all the above tests have been passed successfully.
- If the inspection gives negative results, do not put the apparatus into service but contact us if necessary.
- Only supply the module with circuit-breakers open.

Subject of inspection	Procedure	Positive test	
1	Apparatus operations.	With the apparatus open perform racking in, carry out a few openings and closings.	Normal operations and signals.
2	Mechanical and electrical lock for preventing apparatus closing in the position between connected and isolated.	Put the truck in the intermediate position between isolated and connected. Attempt contactor closing.	Closing is not possible.
3	Truck locking electromagnet.	De-energise the electromagnet and try to move it using the relevant handle.	The truck does not move.
4	Mechanical lock for preventing apparatus racking in/out when closed.	Put the truck in the isolated position, close the apparatus and try the racking in operation.	The operation is not possible.
5	Key lock for preventing racking in (if supplied).	With the contactor in the isolated position, turn the key 90°.	Apparatus racking-in is prevented after about two handle turns. The key can be removed.
6	Shutter mechanical lock when the apparatus is withdrawn (if supplied).	With apparatus withdrawn try to manually move the shutters.	It is not possible to open the shutters.
7	Earthing switch (if supplied).	With isolated apparatus, close the earthing switch and re-open it.	The operation is possible. Check that the position signalled on the circuit-breaker front is correct.
		Try to close the earthing switch with the apparatus inserted.	The earthing switch cannot be closed.
		Try to insert the apparatus with isolated apparatus and earthing switch closed.	The operation is prevented after about two handle turns.
		Try to operate the earthing switch with the apparatus in the intermediate position between isolated and connected.	The earthing switch operating lever cannot be inserted.
8	Key lock for earthing switch open (if supplied).	Turn the key 90° with apparatus isolated, earthing switch open and lever withdrawn.	The earthing switch operating lever cannot be inserted.
9	Key lock for earthing switch closed (if supplied).	Turn the key 90° with apparatus isolated, earthing switch closed and lever withdrawn.	The earthing switch operating lever cannot be inserted.
10	Double key lock for earthing switch open and closed (if supplied).	Turn the key 90° with apparatus isolated, earthing switch open and lever withdrawn.	The earthing switch operating lever cannot be inserted.
		Turn the key 90° with apparatus isolated, earthing switch closed and lever withdrawn.	The earthing switch operating lever cannot be inserted.
11	Earthing switch electromechanical lock (if supplied).	With earthing switch open or closed and lock de-energised.	The earthing switch operations are not possible.

After performing the tests, make sure that all normal service conditions are restored.

Check that all the mechanical and electrical locks, (if de-energised to carry out the putting into service tests with switchboard disconnected) have been restored.

9. Periodic checks



- **The periodic checks must be carried out by skilled personnel.**
- **Before carrying out any operation, make sure that the apparatus is open with springs discharged.**
- **With apparatus with magnetic actuator check that capacitors are discharged.**

At least for the first check, it is advisable to follow what is specified in the table.

According to the results obtained, establish the best interval for subsequent operations.

It is advisable to keep a maintenance card and a service book containing all the operations performed along with date, description of possible anomalies, reference to the data needed to identify the apparatus (see chapter 2) etc.

For further information, refer to article 10 of IEC 60694 Standards.

In any case, should there be any problems, do not hesitate to contact us.

It is recommendable to perform an inspection within one year from putting the apparatus into service.

9.1. General information

During normal service the fixed parts are maintenance-free. Any possible intervention depends on specific installation aspects such as operation frequency, interrupted current value, power factor and ambient conditions.

As a precaution, the paragraph below shows the inspection programme table with the relevant periodic checks.

9.2. Inspection programme

Subject of inspection	Time intervals	Procedure
1 Visual inspection of insulating parts.	3 years depending on ambient pollution.	Insulating parts must be free from dust, dirt, cracks, traces of surface discharges and damage. Remove any dust and dirt by means of a vacuum cleaner and dry, clean cloths.
2 Auxiliary contacts.	3 years.	Check functionality and signals.
3 Auxiliary circuit conductors.	5 years.	Check whether any cabling strap is loose or broken and connection tightness.
4 Interlocks.	3 years.	Check device functionality.
5 Visual inspection of earthing switch contacts.	5 years.	Check that contacts are not deformed, eroded or oxidised. Lubricate the contacts with Molydal EL/5 (Industrial Service) grease or Vaseline.
6 Power connections.	3 years.	The connections must be tight and have no traces of overheating or oxidisation.
7 Insulation resistance measurement.	3 years.	See para. 8.1. (table).



For the routine checks and maintenance of apparatus and protection devices, please refer to the relative instruction manuals.

10. Maintenance operations



- **Maintenance must be carried out either by our personnel or by qualified skilled personnel. Should the customer's personnel be in charge of maintenance, the customer is responsible for any operation performed on the apparatus.**
- **While performing routine checks and maintenance operations, de-energise all the components.**
- **The spare parts shown in the table “List of spare parts/accessories” can only be replaced by our personnel. For the apparatus, consult the relevant manuals.**
- **Use original spare parts only.**

10.1. General information

Thanks to their simple design, fixed parts do not require any particular maintenance except for the “Periodic checks” in paragraph 9.

In order to avoid any hazardous deterioration of the insulating level, it is advisable to perform the first inspection six months after putting into service so as to establish the routine check intervals and the maintenance card.

Moreover, it is recommendable to follow the instructions for the single items according to the instruction manuals supplied with the apparatus.

It is advisable to keep a maintenance card and a service book containing all the operations performed along with date, description of possible anomalies, reference to the data needed to identify the apparatus (see chapter 2) etc. For further information, refer to article 10 of the IEC 60694 Standards.

Should you have any problems, do not hesitate to contact us. The electrical apparatus is easily affected by ambient conditions and can be damaged by abnormal service conditions.

Dust, heat, humidity, corrosive atmosphere, chemical residues, fumes, vibrations and other elements can influence apparatus performances and the life of the electrical apparatus.

Especially when combined, these conditions cause premature faults.

The most important rules to follow are:

- keep clean;
- keep dry;
- tighten bolts and connections;
- preserve the mechanical parts from excessive friction.

The instructions concerning the operations to be carried out on the various parts of the module, excluding the apparatus for which the relevant instruction manuals should be referred to.

10.2. Metallic structure

This comprises the supporting construction complete with vertical and horizontal segregating sheets. These parts are galvanised.

Galvanised components

The galvanised and passivated components can be cleaned by means of a dry cloth.

Oil and grease can be removed using a cloth soaked in a suitable solvent. To polish the surface, repeat the previous operation.

10.3. Mechanical actuators

The mechanical actuators comprise all the mechanical parts of the fixed part for carrying out the operations, locks and safety devices. The force, prevention and safety locks are all considered mechanical actuators.

The moving components are lubricated and tested while assembling the fixed part.



The mechanical interlocks must not be ignored, but used properly so as to avoid any hazardous situations.

The mechanical interlocks must reach the final locked/unlocked positions without any intermediate stops. They must be tested several times to check that they operate perfectly. The operating force required must also be checked. Always make sure that the mechanical interlock position corresponds with the position of both the part controlled device and with the interlocked apparatus.

If excessive force is required to activate the device it means that the mechanism is prevented from moving.

In this case, please contact us.

11. Accessories and spare parts



- **Either our personnel or qualified skilled customer personnel must mount the spare parts and/or the accessories carefully following the instructions enclosed.**
- **Before performing any operation make sure that all the apparatus is open and de-energised (main circuit and auxiliary circuits).**

To order spare parts or accessories, always specify the serial number of the fixed parts in which the spare parts are to be installed.

For any enquiry about spare part availability and ordering, please contact us.

11.1. Accessories and tools for operations

Standard completion accessories:

The fixed part is usually supplied complete with:

- operating lever for any earthing switches;
- handle for circuit-breaker racking in/out;
- diagrams;
- instructions for installation, service and maintenance.

Other components (on request)

- shutter Fail-safe device;
- contact for signalling connected and key lock on earthing truck insertion.

11.2. Spare parts

For the apparatus, refer to the relative installation, service and maintenance instructions.

For fixed part is available the earthing switch.

Installation at customer care.

For more information please contact:

ABB S.p.A.

**Power Products Division
Unità Operativa Sace-MV**

Via Friuli, 4

I-24044 Dalmine

Tel.: +39 035 6952 111

Fax: +39 035 6952 874

E-mail: info.mv@it.abb.com

ABB AG

Calor Emag Medium Voltage Products

Oberhausener Strasse 33

D-40472 Ratingen

Phone: +49(0)2102/12-1230,

Fax: +49(0)2102/12-1916

E-mail: powertech@de.abb.com

www.abb.com

The data and illustrations are not binding. We reserve the right to make changes without notice in the course of technical development of the product.

© Copyright 2013 ABB. All rights reserved.