

ABB DRIVES

Converter module lifting device for drive cabinets

Hardware manual

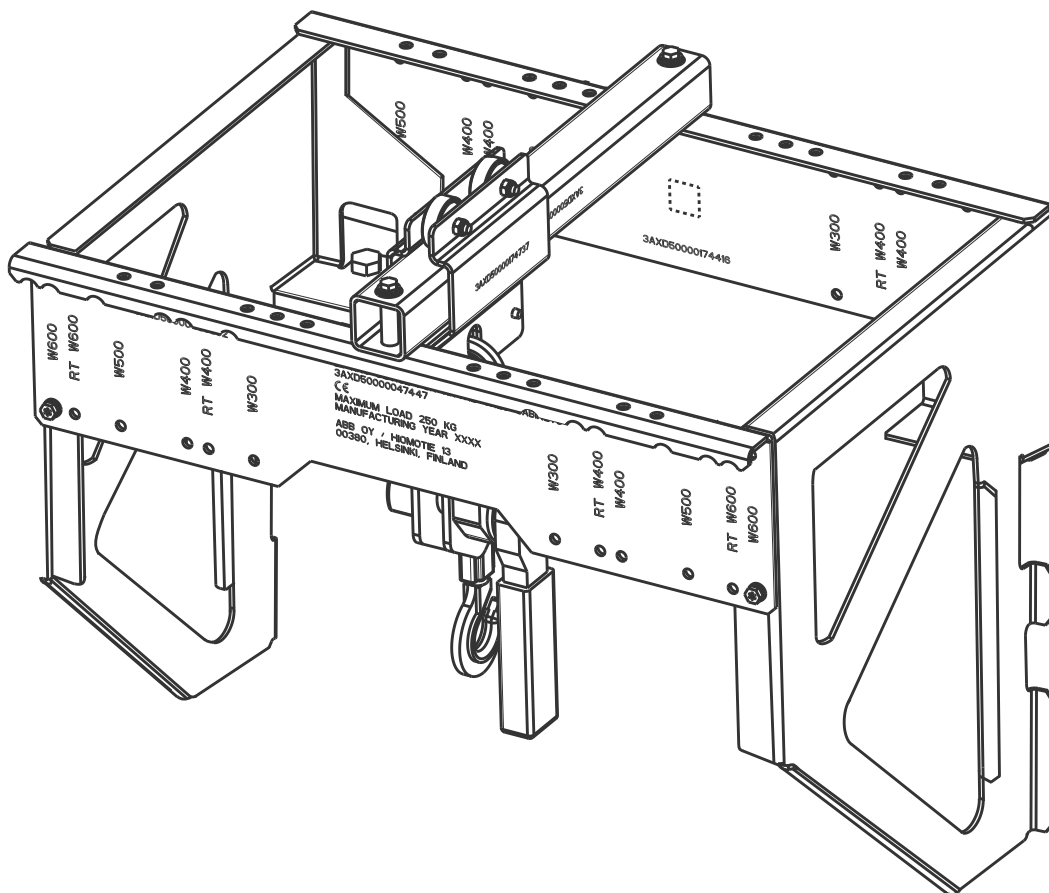

Converter module lifting device for drive cabinets

Hardware manual

Table of contents



1. Safety instructions



4. Mechanical installation



Table of contents

1 Safety instructions

Contents of this chapter.....	7
Complete safety instructions of the drive.....	7
Electrical safety precautions.....	8

2 Introduction to the manual

Contents of this chapter.....	11
Applicability.....	11
Compatibility.....	11
Target audience.....	12
List of related manuals.....	13
Converter module lifting device for the ABB Drives cabinet.....	13
Converter module lifting device for the Rittal TS8 and Rittal VX25 cabinet.....	13

3 Hardware description

Contents of this chapter.....	15
Overview of the lifting device.....	15

4 Mechanical installation

Contents of this chapter.....	17
Before installing the lifting device.....	17
Unpacking the converter module lifting device for ABB Drives cabinet.....	19
Unpacking the converter module lifting device for Rittal VX25 cabinet.....	20
Unpacking the converter module lifting device for Rittal TS8 cabinet.....	21
Installing the converter module lifting device.....	22
Exception for the IP54 drive cabinet (option +B055).....	22

5 Operation

Contents of this chapter.....	23
Operating limits.....	23
Installing the converter module lifting beams/supports.....	23
Using the lifting device.....	25
Information of the winch.....	27

6 Packing the lifting device after the use

Contents of this chapter.....	29
Packing.....	29

7 Maintenance

Contents of this chapter.....	31
Maintenance information.....	31
Declarations of conformity.....	31
Certificates.....	32



6 Table of contents

Further information



1

Safety instructions

Contents of this chapter

This chapter contains the references to the complete safety instructions of the drive, and the electrical safety precautions.

Complete safety instructions of the drive



▲WARNING Obey the safety instructions of the drive. If you ignore them, injury or death, or damage to the equipment can occur.

If you are not a qualified electrician, do not do installation or maintenance work.



▲WARNING Make sure that persons will not be in a danger during the installation and use of the lifting device.

Make sure that the lifting device is installed and used in accordance with good and safe working practices.

Depending on the drive type, you can find the safety instructions either in the drive hardware manual (ABB single drive cabinets and modules), or in the separate safety instructions manual (ABB multidrive cabinets and modules).



Electrical safety precautions

These electrical safety precautions are for all persons who do work on the drive, motor cable or motor.

This procedure gives information on how to de-energize the drive and make it safe to do work on it. The procedure does not include all possible drive configurations. Each drive is made to order. Always refer to the circuit diagrams of the drive delivery.



⚠ WARNING Obey these instructions. If you ignore them, injury or death, or damage to the equipment can occur. If you are not a qualified electrical professional, do not do electrical installation or maintenance work. Do these steps before you do installation or maintenance work.

1. Prepare for the work.
 - Make sure that you have a work order.
 - Do an on-site risk assessment or job hazard analysis.
 - Make sure that you have the correct tools available.
 - Make sure that the workers are qualified.
 - Select the correct personal protective equipment (PPE).
 - Stop the drive and motor(s).
2. Clearly identify the work location and equipment.
3. Disconnect all possible voltage sources. Make sure that connection is not possible. Lock out and tag out.
 - If the drive is equipped with a DC/DC converter unit or a DC feeder unit: Open the disconnecting device of the energy storage connected to the unit. The disconnecting device is outside the drive cabinet. Then open the DC switch-disconnector ([Q11], option +F286 or +F290) of the unit.
 - Open the main disconnecting device of the drive.
 - Open the charging switch if it is present.
 - Open the disconnecter of the supply transformer. (The main disconnecting device in the drive cabinet does not disconnect the voltage from the AC input power busbars of the drive cabinet.)
 - Open the auxiliary voltage switch-disconnector (if it is present), and all other possible disconnecting devices that isolate the drive from dangerous voltage sources.
 - In the liquid cooling unit (if present), open the switch-disconnector of the cooling pumps.
 - If there is a permanent magnet motor connected to the drive, disconnect the motor from the drive with a safety switch or by other means.
 - Open the main isolating device of the drive.
 - Disconnect all dangerous external voltages from the control circuits.
 - After you disconnect power from the drive, wait 5 minutes to let the intermediate circuit capacitors discharge before you continue.
4. Protect other energized parts in the work location against contact and take special precautions when close to bare conductors.
5. Measure that the installation is de-energized. Use a high-quality voltage tester. If the measurement requires that you remove shrouding or other cabinet structures,



obey the local laws and regulations applicable to live electrical work. This includes, but is not limited to, electric shock and arc protection.

- Before and after you measure the installation, verify the operation of the voltage tester on a known voltage source.
- Make sure that the voltage between the input power terminals of the drive (L1, L2, L3) and the grounding (PE) busbar is zero.
- Make sure that the voltage between the output power terminals of the drive (U, V, W) and the grounding (PE) busbar is zero.

Important! Repeat the measurement with the DC voltage setting of the voltage tester. Measure between each phase and ground. There is a risk of dangerous DC voltage charging due to leakage capacitances of the motor circuit. This voltage can remain charged for a long time after the drive power-off. The measurement discharges the voltage.

- Make sure that the voltage between the drive DC busbars and the grounding (PE) busbar is zero.
- If the drive is equipped with a DC/DC converter unit or a DC feeder unit: Make sure that the voltage between the energy storage terminals of the unit (ES+ and ES-) and the grounding (PE) busbar is zero.



▲WARNING The busbars inside the cabinet of liquid-cooled drives are partially coated. Measurements made through the coating are potentially unreliable, so only measure at uncoated portions. Note that the coating does not constitute a safe or touch-proof insulation.



6. Install temporary grounding as required by the local regulations.
7. Ask for a permit to work from the person that is responsible for the electrical installation work.



Introduction to the manual

Contents of this chapter

This chapter describes the manual.

Applicability

This manual applies to:

- converter module lifting device for the ABB Drives cabinet
- converter module lifting device for the Rittal VX25 cabinet
- converter module lifting device for the Rittal TS8 cabinet.

Compatibility

The converter module lifting device for the ABB Drives cabinet is compatible with the cabinet-installed drives delivered by ABB.

The converter module lifting device for the Rittal VX25 cabinet is compatible with the ABB converter modules that are installed into a Rittal VX25 cabinet by system integrator according to the instructions by ABB Drives.

The converter module lifting device for the Rittal TS8 cabinet is compatible with cabinet-installed ABB converter modules in Rittal TS8 cabinet.

The tables below show compatibility details: Cubicle widths, product series, and converter module frame sizes.

Cabinet/cubicle width (mm)	ABB Drives cabinets	Rittal VX25 cabinets	Rittal TS8 cabinets
300	X		
400	X	X	X
500	X		
600	X	X	X
700	X		
800	X	X	X
1000	X ¹⁾		

¹⁾ Lifting device is compatible if a separate w1000 conversion kit is installed as well (3AXD50000699384).

Product family	Frame ¹⁾
ACS800	R7i
ACS800 LC	R7i, R8i, D3, D4
ACS580, ACH580, ACQ580	R6-R9
ACS880	R6-R9, R6i, R7i, D6D, D7D/T
ACS880 LC	R7i, R8i, D8T, BDCL xxLC-x, inductors of BLCL-xxLC-x
ACS880U ²⁾	R7...R9
ACS880R ²⁾	R6i, R7i, H6, H7
ACS880R LC ²⁾	R8i, D8T

¹⁾ In addition to the converter modules listed in the table above, the lifting device can also be used for lifting other ABB-delivered components in the cabinet. The component must have two lifting points, and weigh under 250 kg.

²⁾ Lifting device revision D or later is compatible with these drive types.

For some module frame sizes in the liquid-cooled ACS880 and ACS800 product series, ABB recommends the use of an additional service platform. Refer to the list below for such module frame sizes and the applicable service platforms.

- For ACS880 R7i, R8i liquid-cooled module frames, 3AXD50001240578
- For ACS800 R8i, D3, D4 liquid-cooled module frames, 68847711

Target audience

This manual is for all personnel who install and use the lifting device. Read the manual before you start the work.

List of related manuals

■ Converter module lifting device for the ABB Drives cabinet

- Cabinet installed single drive: appropriate drive hardware manual
- Cabinet installed multidrives: appropriate supply/inverter/brake/converter unit hardware manual and appropriate safety instructions manual for multidrive cabinets and modules
- Lifting device documentation: refer to section [Unpacking the converter module lifting device for ABB Drives cabinet \(page 19\)](#).

■ Converter module lifting device for the Rittal TS8 and Rittal VX25 cabinet

- Single drive modules: appropriate drive hardware manual
 - Multidrive modules: appropriate supply/inverter/brake/converter module hardware manual(s)
 - Multidrive modules: safety instructions for appropriate multidrive cabinets and modules
 - Manuals/documents defined by the system integrator or the cabinet installed drive
 - Lifting device documentation: refer to section [Unpacking the converter module lifting device for Rittal VX25 cabinet \(page 20\)](#), or [Unpacking the converter module lifting device for Rittal TS8 cabinet \(page 21\)](#).
-

3

Hardware description

Contents of this chapter

This chapter contains a description of the lifting devices.

Overview of the lifting device

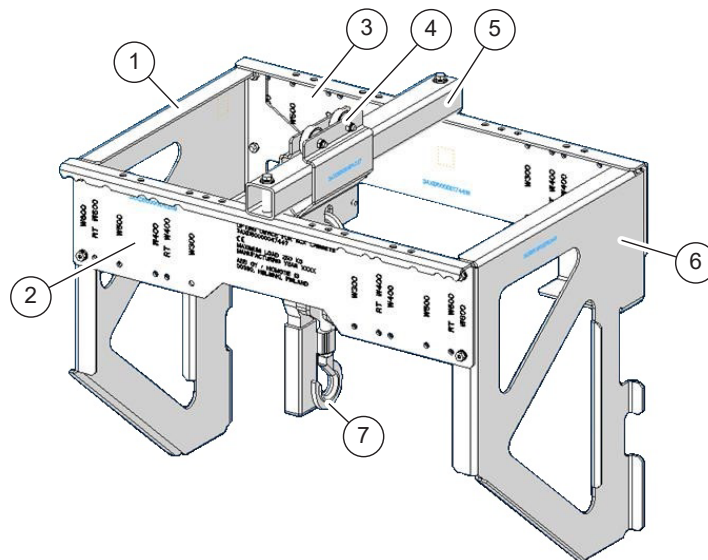

1	Left side plate	5	Lifting beam
2	Front horizontal beam	6	Right side plate
3	Rear horizontal beam	7	Lifting accessories (winch)
4	Winch slide		

16 Hardware description

The figures below show the differences between the lifting device variants. The side support plates differ, otherwise the lifting devices are similar.

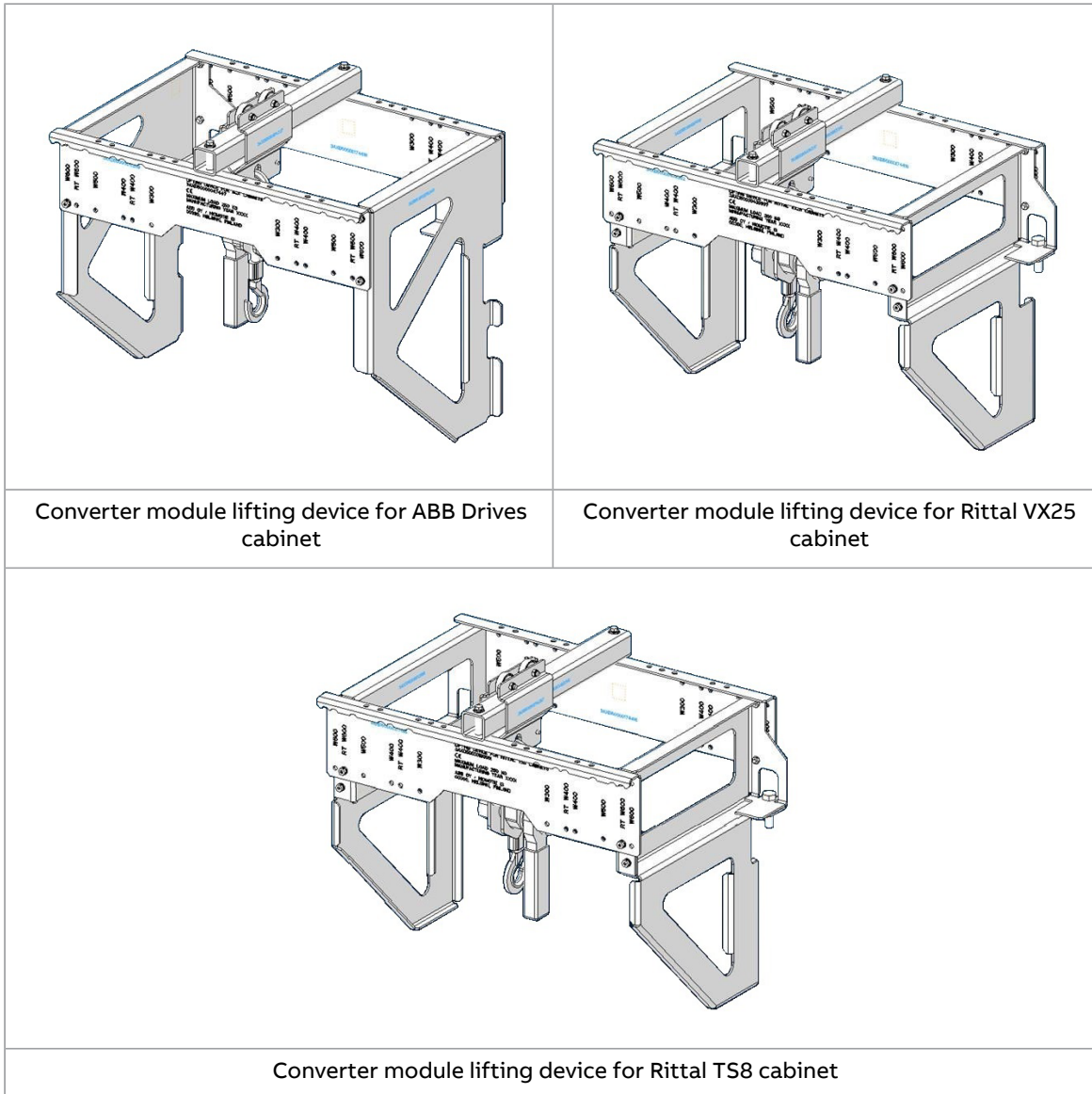

4

Mechanical installation

Contents of this chapter

This chapter contains the installation instructions of the lifting device.

Before installing the lifting device

Before you start the installation of the lifting device:

- Make sure that the lifting device is compatible with the cabinet and the converter module to be lifted. Refer to sections [Applicability \(page 11\)](#) and the side of the package to identify the lifting device.
- Make sure that the drive cabinet door can open 135 degrees. If it cannot, either remove the parts on the door that prevent the opening (such as door air inlet grille), or remove the whole door.



18 Mechanical installation

- **ABB drive cabinets:** Remove the marine supports/lifting eye-bolts at the front of the roof (a) (if any). The front cover of the roof (b) can also be removed (not necessary). Refer to the figure below.
- **Rittal VX25 and TS8 cabinets:** Remove any lifting eye bolts from the mounting points of the lifting device.



▲WARNING Do not install the lifting device to a cabinet that it is not compatible with.

Lift only those converter modules that the lifting device is intended for.

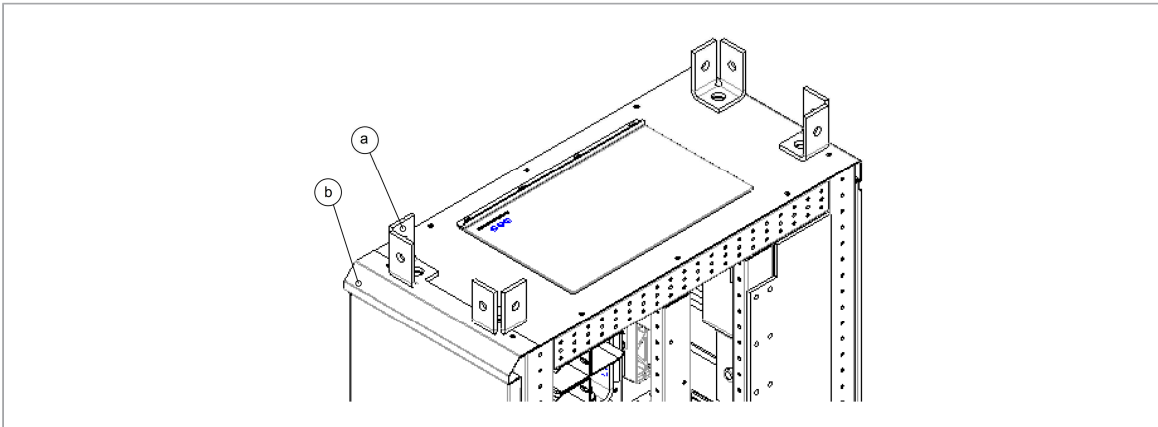

Unpacking the converter module lifting device for ABB Drives cabinet

Check the right ID of the package: 3AXD50000047447

Check the contents of the package:

- parts of the lifting device (refer to the illustration below)
- lifting device assembly drawing (3AXD50000179398)
- winch operating manual
- this manual (3AXD50000210628)
- layout drawing of the lifting device package (3AXD50000193950)

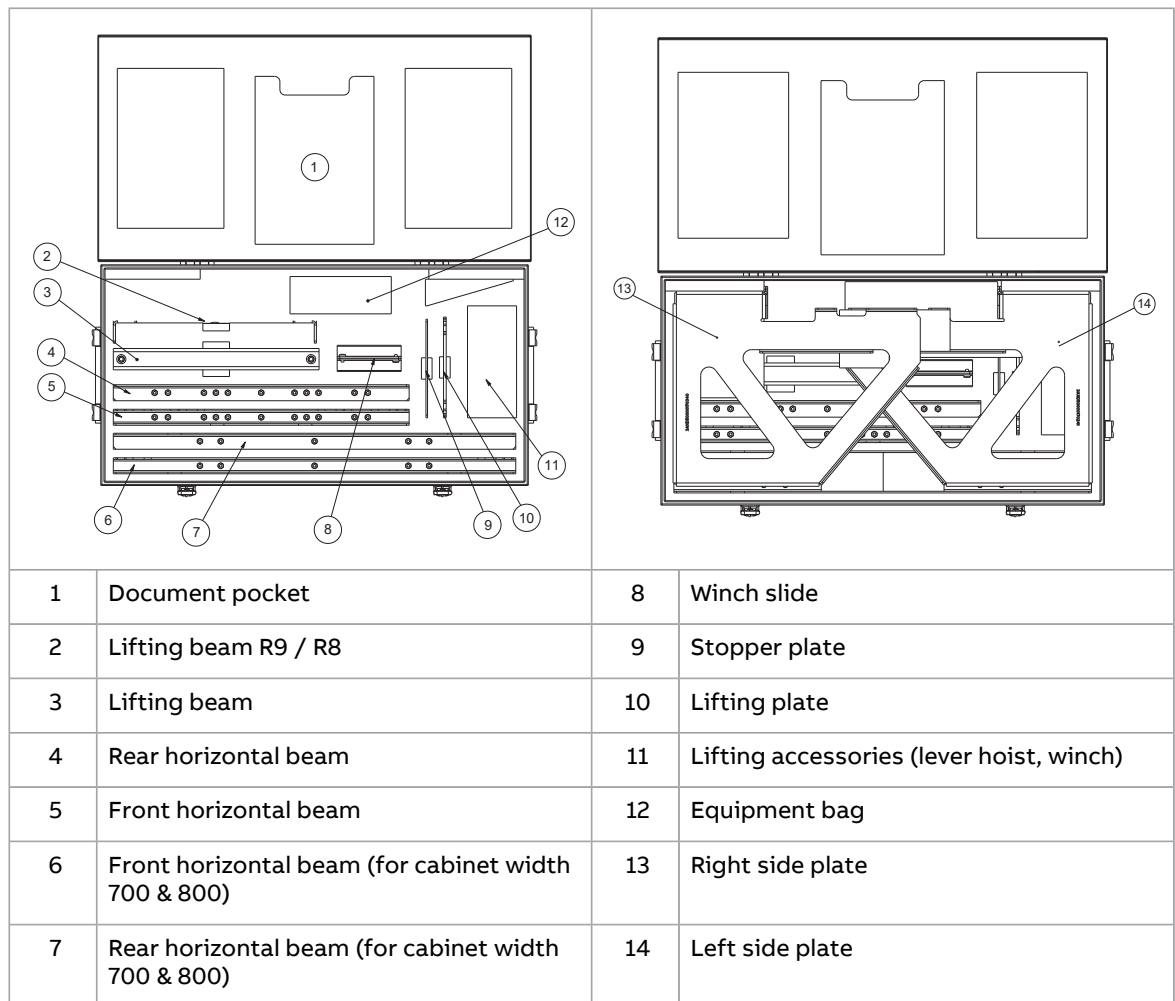

Unpacking the converter module lifting device for Rittal VX25 cabinet

Check the right ID of the package: 3AXD50000439997

Check the contents of the package:

- parts of the lifting device (refer to the illustration below)
- lifting device assembly drawing (3AXD50000439409)
- layout drawing of the lifting device package (3AXD50000440979)
- this manual (3AXD50000210268)
- winch operating manual

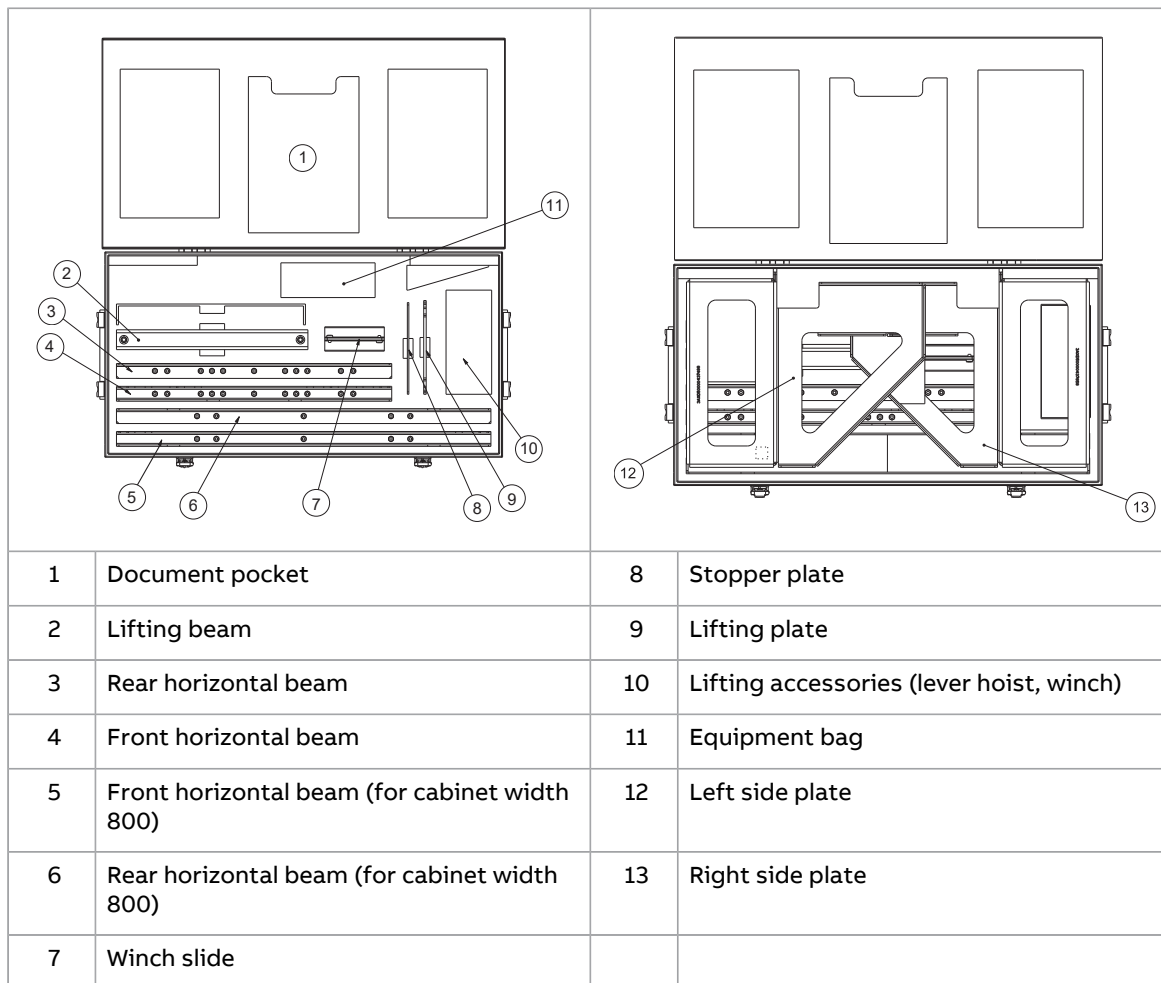

Unpacking the converter module lifting device for Rittal TS8 cabinet

Check the right ID of the package: 3AXD50000196661

Check the contents of the package:

- parts of the lifting device (refer to the illustration below)
- lifting device assembly drawing (3AXD50000183333)
- layout drawing of the lifting device package (3AXD50000199747)
- this manual (3AXD50000210268)
- winch operating manual

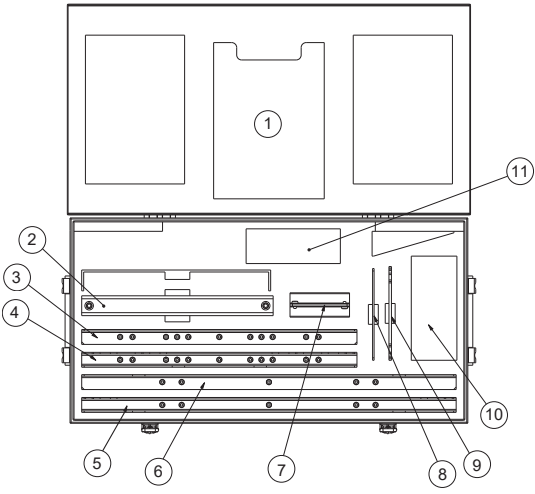
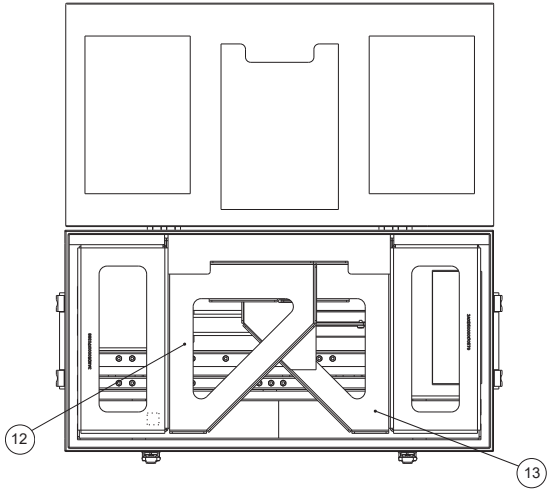
			
1	Document pocket	8	Stopper plate
2	Lifting beam	9	Lifting plate
3	Rear horizontal beam	10	Lifting accessories (lever hoist, winch)
4	Front horizontal beam	11	Equipment bag
5	Front horizontal beam (for cabinet width 800)	12	Left side plate
6	Rear horizontal beam (for cabinet width 800)	13	Right side plate
7	Winch slide		



Installing the converter module lifting device



⚠ WARNING Do not install the lifting device to a cabinet that it is not compatible with. Lift only those converter modules that the lifting device is intended for.



⚠ WARNING Stop the drive and do the steps in section [Electrical safety precautions](#) (page 8) before you start to work.

Follow the step-by-step installation instructions in the assembly drawing:

- ABB Drives cabinet (3AXD50000179398)
- Rittal VX25 cabinet (3AXD50000439409)
- Rittal TS8 cabinet (3AXD50000183333)

Tighten the bolts to the torques defined in the assembly drawing.

■ Exception for the IP54 drive cabinet (option +B055)

The roof of the IP54 drive cabinet (option +B055) prevents the lifting device installation in the exact order shown in the assembly drawing.

Instead, you must:

1. Attach the back support plate to the side plates.
2. Attach this subassembly to the cabinet.

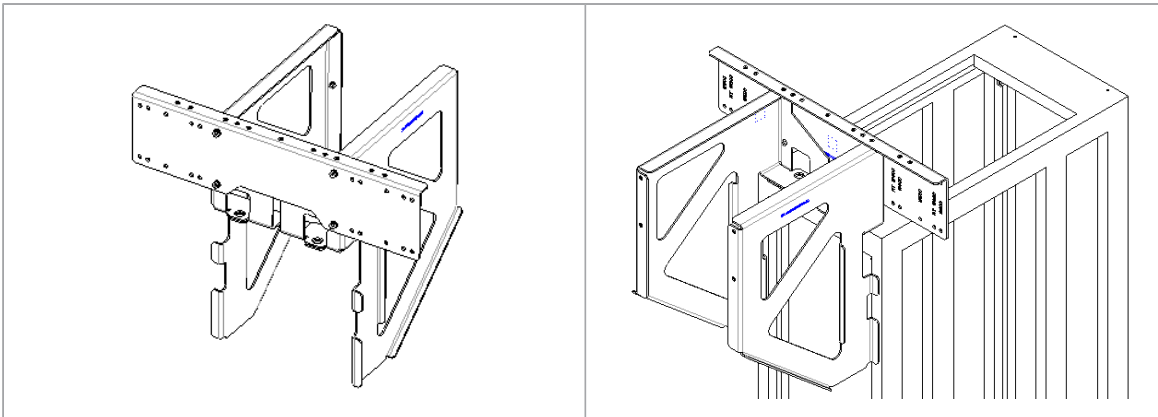

5

Operation

Contents of this chapter

The chapter contains the operating guidelines of the lifting device.

Operating limits

Lifting device:

Maximum load: 250 kg

Maximum lifting angle: 0 degrees

Lifting slings:

Chain width and material: 4 mm steel chain

Maximum lifting angle: 60 degrees

Maximum load: Depends on the lifting angle. Refer to the table below.

Chain	0-45 degree	45-60 degree
4 mm	880 kg	630 kg

Installing the converter module lifting beams/supports

The lifting device package contains two lifting beams/supports. You must use them when lifting certain converter module frame sizes. The table below shows the converter modules, and the compatible lifting beam/supports.

24 Operation

Note: When you use lifting beam/support, connect the lifting device directly to the beam/support. Do not use chain slings.

Lifting beam	ACS880 frames	ACS580, ACH580, ACQ580 frames
3AXD50000002054	R6i	-
3AXD50000002054	R7i	-
3AXD50000002054	D6D	-
3AXD50000002054	D7D/T	-
3AXD50000195305	-	R8
3AXD50000195305	-	R9

Install the lifting beam 3AXD50000002054 according to the illustrations below. Use the two M6x16 combiscrews in the package.

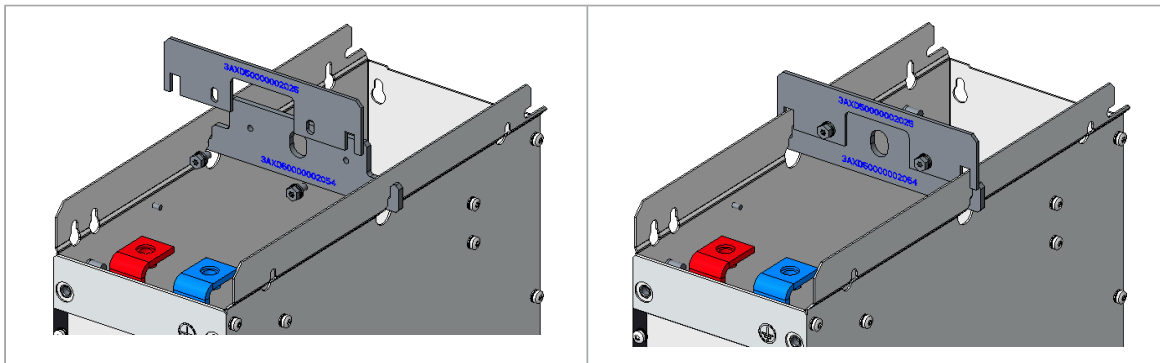

Install the lifting beam 3AXD50000195305 according to the illustration below. Use the two M12x25 bolts and M12 nuts in the package.

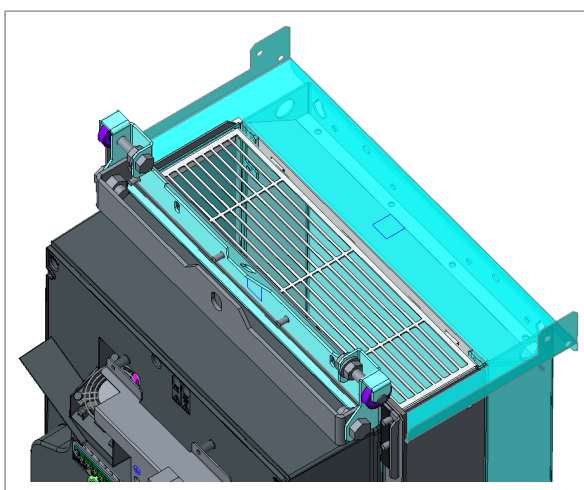

Using the lifting device



⚠WARNING Obey the instructions given in the winch manual.

Test the winch brake before using the winch.



⚠WARNING Obey the instructions for the converter module installation/replacement. Refer to the appropriate hardware manual.



⚠WARNING Stop the drive and do the steps in section [Electrical safety precautions \(page 8\)](#) before you start to work.

1. Align the winch with the converter module to be lifted.

Make sure there is no left/right lifting angle.

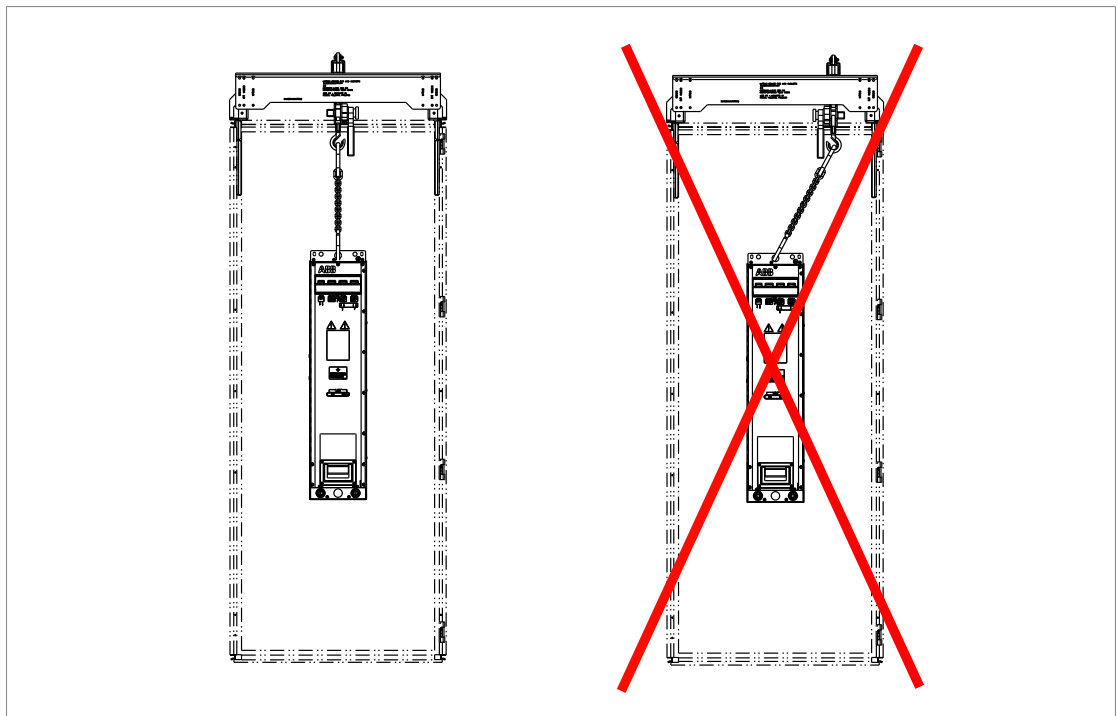

2. Lifting with lifting beams/supports: make sure that the lifting beams/supports are installed. Refer to [Installing the converter module lifting beams/supports \(page 23\)](#). Connect the winch directly to the lifting beams/supports.

Lifting with chain slings: attach the chain slings to the winch and to the converter module lifting points. Refer to the appropriate hardware manual for the lifting point locations. Adjust the length of the chain slings by using the shortening hooks. Make sure that the winch and chain slings hooks are locked.

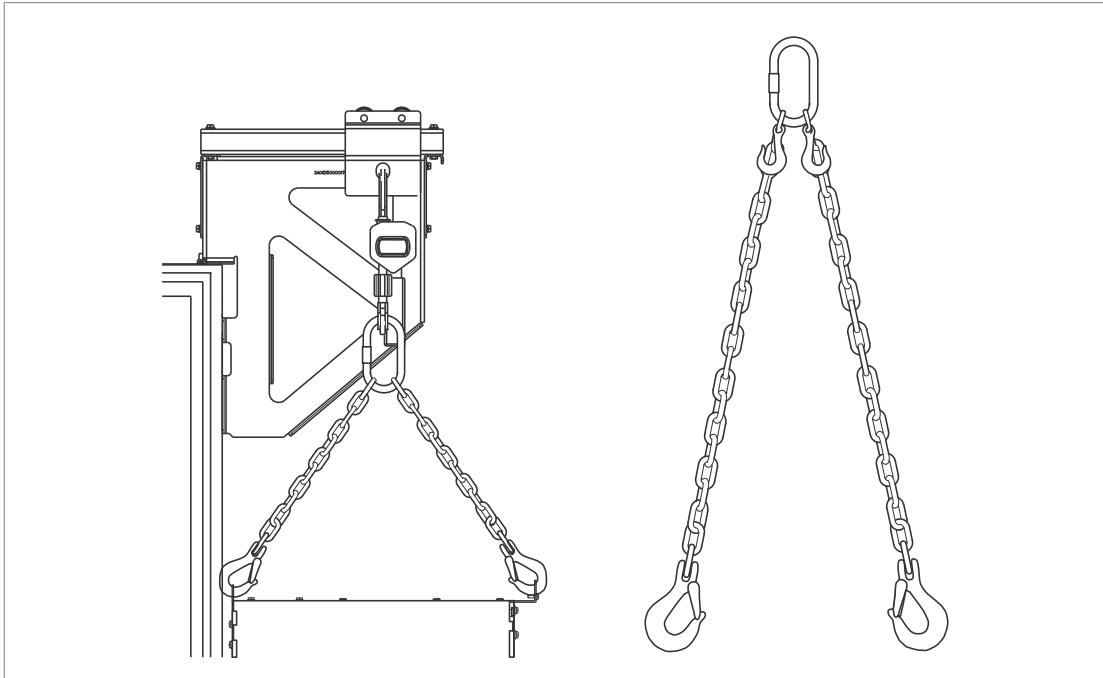

3. Adjust the manual lever of the winch to the right position:
 - UP = Move module upwards with the winch.
 - DN = Move module downwards with the winch.
4. Operate the winch to tighten the slings first, and then continue carefully so that the winch carries the load entirely.
Lift/lower the load to the desired position.
5. Before you release the load or remove the lifting slings/winch hooks, attach the module to a supporting structure:
 - If you are removing the module from the cabinet: attach the module to the truck pallet.
 - If you are installing the module into a cabinet: attach the module to the cabinet.
6. Release the load.
7. Turn the winch lever to the neutral (N) position and remove the lifting hooks from the module.

Information of the winch

Refer to the winch manual delivered with the winch in the lifting device package. Read the manual before using the winch.

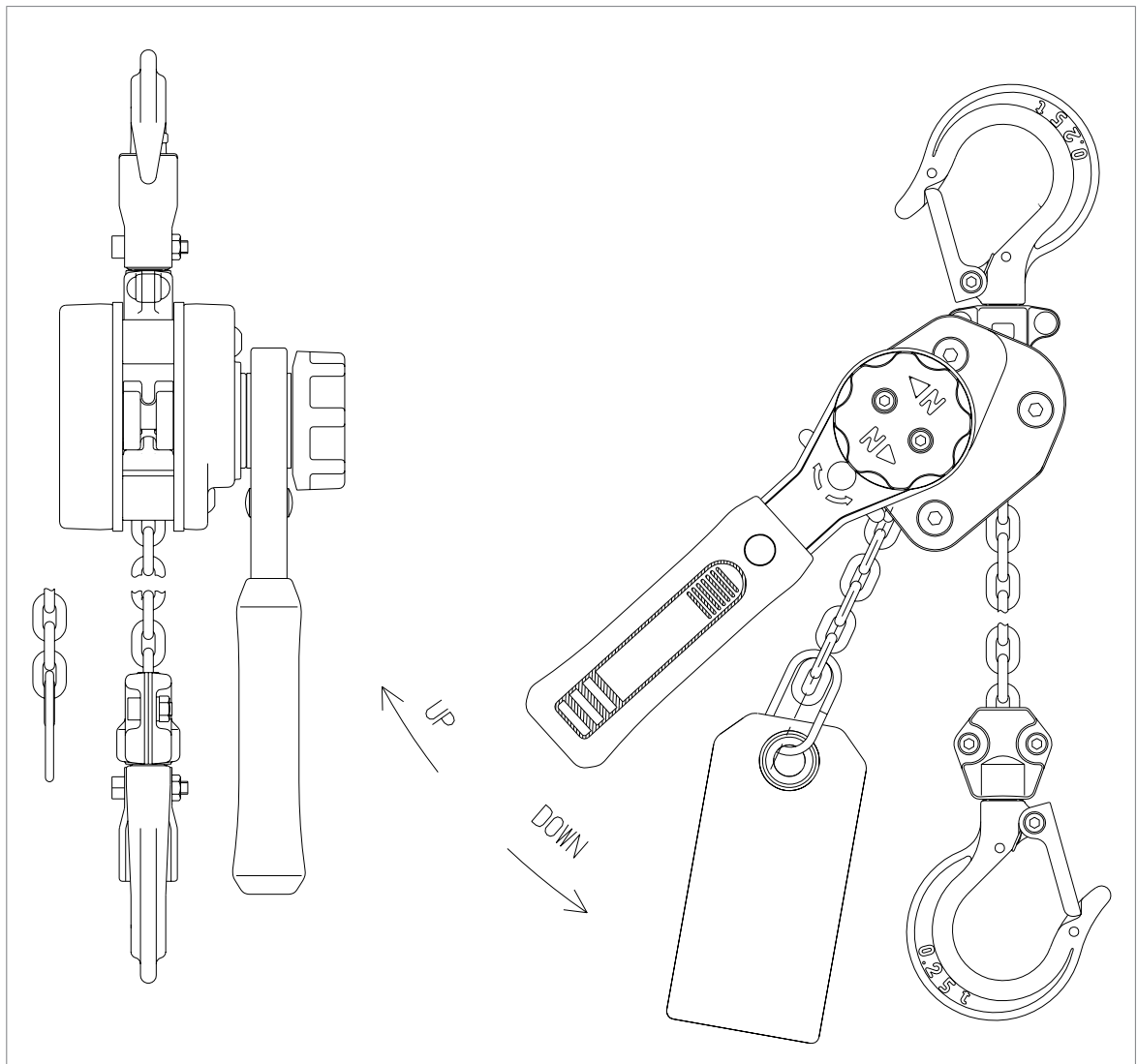



Packing the lifting device after the use

Contents of this chapter

This chapter contains instructions on packing and storing the lifting device.

Packing

After use, pack the lifting device back into its package:

1. Check that all parts of the lifting device are in good condition.
If there are any defects that will prevent future use of the lifting device, purchase a new lifting device.
2. Pack the lifting device parts to the package.

Note: For the layout of the package, refer to section:

- ABB Drives cabinets: [Unpacking the converter module lifting device for ABB Drives cabinet \(page 19\)](#)
 - Rittal VX25 cabinets: [Unpacking the converter module lifting device for Rittal VX25 cabinet \(page 20\)](#)
 - Rittal TS8 cabinets: [Unpacking the converter module lifting device for Rittal TS8 cabinet \(page 21\)](#)
3. Store the lifting device and its packaging in a dry place.

7

Maintenance

Contents of this chapter

The chapter contains information about the lifting device maintenance, declarations of conformity and certificates.

Maintenance information

Inspect the converter module lifting device, winch and chain slings before you use them.

For the maintenance of the winch, refer to the winch manual.

■ Declarations of conformity



[Link to Declaration of conformity according to EU Machinery Directive 2006/42/EU \(3AXD10000665649\)](#)



[Link to Declaration of conformity according to UK Supply of Machinery \(Safety\) Regulations 2008 \(3AXD10001329583\)](#)

■ **Certificates**



KIWA Inspecta Certificate for ACS800, ACS880, ACS580 drive modules lifting equipment (3AXD10000686644)

Further information

Product and service inquiries

Address any inquiries about the product to your local ABB representative, quoting the type designation and serial number of the unit in question. A listing of ABB sales, support and service contacts can be found by navigating to new.abb.com/contact-centers.

Product training

For information on ABB product training, navigate to new.abb.com/service/training.

Providing feedback on ABB manuals

Your comments on our manuals are welcome. Navigate to forms.abb.com/form-26567.

Document library on the Internet

You can find manuals and other product documents in PDF format on the Internet at www.abb.com/drives/documents.



www.abb.com/drives



3AXD50000210268F