

# Robot bio

## The life and times of the electrical industrial robot

**TOMAS LAGERBERG, JAN JONSON – A new age of industrial automation was ushered in when the electrical industrial robot was born in Västerås, Sweden in the early 1970s. This is the story of the origins and the current state of industrial robots, and a look into their exciting future and the promise they hold for mankind.**

The story of the industrial robot started in 1954 when George Devol patented the first teachable robot. In 1956, Devol and Joseph Engelberger (later dubbed “the father of the industrial robot”) started the first robot company (Unimation). The first Unimation robot, which was hydraulically driven, was sold to General Motors in 1961 and Unimation’s business started to get interesting when, in 1964, General Motors ordered no less than 66 robots. The first robot in Europe was installed in 1967, at Svenska Metallverken in Upplands Väsby, Sweden.

The potential of robots did not escape the attention of ASEA’s CEO, Curt Nicolin, who came to the conclusion that ASEA should develop their own. This was the genesis of the electrical industrial robot. In the summer of 1971, Nicolin had two of his top engineers, Ove Kullborg and Curt Hansson, look into new approaches to robot design, given that the Unimation products were big, noisy, energy-consuming beasts that leaked copious amounts of oil.

Ove Kullborg and Curt Hansson jotted down some initial ideas. Eventually, a five-axis “manipulator” (the word “robot” first appeared on drawings in 1972) concept was developed; it had an arm that moved vertically and horizontally as well as swung around its base → 1-2.

In April 1972, the ASEA board of directors made a decision to launch a full-scale robot development project and an up-and-coming automation specialist,

---

**The electrical drive system developed by Ove Kullborg’s team was the clear winner.**

Björn Weichbrodt, was chosen as project leader. A first prototype was to be shown to the board in February 1973. The project, from the start, included everything from mechanical design and electronics to marketing and application development. The task of developing the mechanical design was taken up by senior designers Ove Kullborg and Bengt Nilsson, each of whom was given the responsibility for a team of around 10 mechanical engineers.

## 1 Initial five-axis concept, including a simple drawing to show proportions

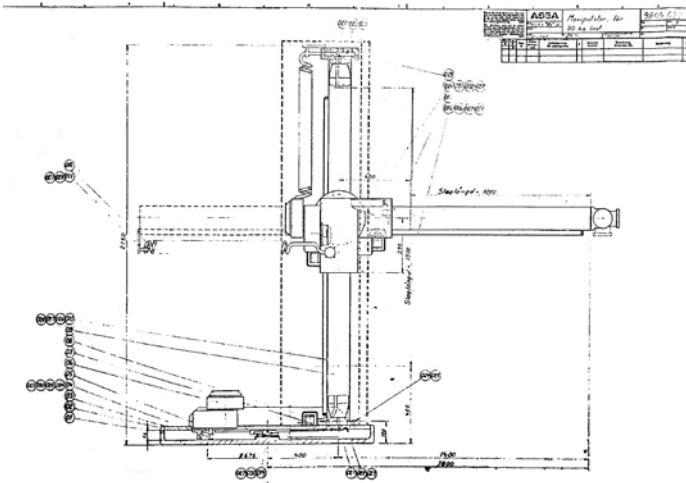

1a One of the early ASEA robot concept drawings

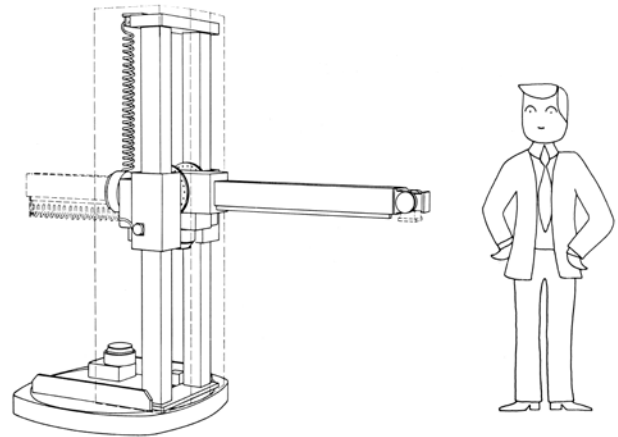

1b The original ASEA robot was to be just over 2 m high

Today, ABB has a large family of industrial robots and has shipped and installed well over 250,000 robots.

An early fundamental choice was the drive concept: hydraulic, pneumatic or electrical? Pneumatics were ruled out due to lack of stiffness in the drive chain, making accuracy and repeatability virtually impossible. Hydraulic robots were prevalent at the time and electrically driven ones rare. To decide which approach should be taken, an internal competition was held in which two teams – lead by Kullborg and Weichbrodt, respectively – designed and built prototypes of the lower three axes of both an electrical and a hydraulic drive train. These were then run side by side. The electrical drive system developed by Kullborg's team was the clear winner.

Another important design choice was the basic robot design. During his time in the United States Weichbrodt had seen prototypes of anthropomorphic robots, ie, robots that mimic the movement pattern of the human arm. He saw this as the way forward for the upcoming ASEA robot.

The third key design choice involved the electronics and programmability of the robot. It was clear early on that conventional electronics provided inadequate flexibility, accuracy and stability. However, a team member had read about a new device called the 8008 microprocessor, developed by an obscure American company called Intel. It was small and could be embedded into control electronics to provide full programmability of the controlled device. The manual the

team requested and received from Intel was, appropriately enough, manually typed with handwritten corrections and had been photocopied many times, which made it hard to read. The team understood enough, though, to realize that the 8008 was exactly what they needed.

Prototype boards were wired with the electronics, but no microprocessors were yet available so the design and code could not be tested. In the end, Weichbrodt had to travel to Intel in California to pick up two microprocessors. The resulting design was a state-of-the-art electronic control system including a basic teach pendant and user interface.

Three basic design decisions had now been made: The ASEA robot was to be electrically driven, anthropomorphic and microprocessor-controlled – features that are nowadays taken for granted.

The IRB 6, as it was now named (Industrial RoBot/6 kg payload), attracted much attention on its public debut in October 1973, when it demonstrated how to pick valve blocks and place them in patterns. The IRB 6's potential was spotted by Magnussons i Genarp, a small workshop in the south of Sweden that, on New Year's Eve, 1973, placed the very first IRB 6 order. Later, in 1974, Magnussons ordered four more IRB 6s and today, more than 40 years later, four of them still perform the same task – polish stainless steel tubes. ABB bought back the

## 2 Early design sketches

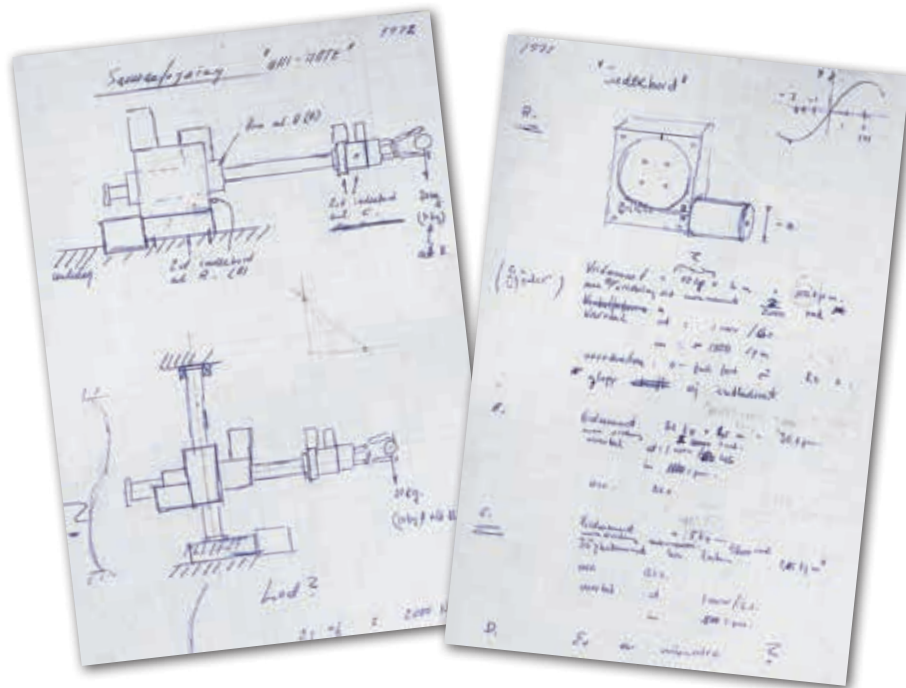

first IRB 6 a few years ago to use as a museum piece.

As with all new and revolutionary products it took some time for volumes to pick up, but by 1978, sales had become large enough to generate a positive cash flow for the ASEA robot business.

Jump now to 2014 and the ABB Capital Markets Day in London. Apart from the usual financial figures and strategy presentations, also revealed to the world for the first time was a new member of the ABB robot family – YuMi®. YuMi was launched as the world's first truly collaborative robot and had been designed from the start to collaborate with humans. Hence the name YuMi: you and me.

The motivation for YuMi came about in 2006 when the need was identified for a robot that could be used in, for example, small-part assembly in mobile phone and small electronics plants in China. The

current assembly plants were almost entirely manual, with thousands of assembly workers standing side by side. It was clear that the robot would have to be able to work beside humans and that it would have to fit in the same space as its human colleagues. This vision, as depicted by a professional illustrator → 3, inspired the team throughout the whole project.

The robot's safety features were paramount. These included two arms (for speed reduction), soft padding on the arms, no-squeeze zones in the joints, lim-

**Three basic design decisions had been made: The ASEA robot was to be electrically driven, anthropomorphic and microprocessor-controlled – features that are nowadays taken for granted.**

ited payload, and limited motor speed and torque. Camilla Kullborg, a mechanical designer in the project, realized that it was

**The third key design choice was in the electronics and programmability of the robot.**

### 3 The vision for the YuMi project



### 4 YuMi – The world's first truly collaborative robot



The IRB 6 attracted a lot of attention on its public debut in October 1973.

not enough for the robot to be safe – it also had to feel and appear safe and from this insight emerged the initial design that finally led to the YuMi that exists today → 4. In 2011, Camilla Kullborg and the YuMi development team were honored with the prestigious “red dot: best of the best” industrial design award.

YuMi was extremely well received and when the product was released for sale at the Hanover Fair in 2015 it was the star of the show. It is no exaggeration to say that YuMi marks the birth of a new era of robotics – the era of truly collaborative robots.

Today, ABB has a large family of industrial robots and has shipped and installed well over 250,000 units, including many world-firsts in robotics: the first arc welding robot, the first electrical paint robot, the first teach pendant with joystick, the first AC drive system on robots, the first virtual robot technology, the first high-level robot programming language, and the first modular robot family. And all that from a humble beginning in 1972 with Björn Weichbrodt – the “father of the electrical robot” – and his first robot.

The industrial robot market is expected to grow rapidly in the coming years. Completely new types of robots are likely to appear: flying robots, swimming robots, walking robots, rolling robots, mi-

cro robots, robots mounted on vehicles, robots that augment human strength and robots that support and collaborate with people – perhaps even in outer space.

Agnes Kullborg, nine year old, daughter of Camilla Kullborg and granddaughter of Ove Kullborg, put her finger on it when asked about the future of robots: “Robots are really cool and they help people. I think that in the future they will help people even more. I’d be interested in working with robots. Maybe design how they are going to look. Maybe something like a future YuMi, because it looks really friendly.” Agnes, representing the third generation in this Kullborg robot family, is, of course, entirely correct.

**Tomas Lagerberg**  
ABB Corporate Research  
Västerås, Sweden  
tomas.lagerberg@se.abb.com

**Jan Jonson**  
Former ABB employee  
ABB Discrete Automation and Motion, Robotics  
Västerås, Sweden