

IRB 1600

The highest performance 10 kg robot



Performance is often a trade off, optimizing for speed or accuracy. With ABB's IRB 1600, you don't have to choose. The robot's cycle times are shorter, sometimes half that of other robots, allowing you to increase throughput. Meanwhile, you will enjoy the work piece quality that only an ABB robot can offer. Extra everything.

Double your throughput

The IRB 1600 has up to 50 percent shorter cycle times than competing robots in material handling, machine tending and process applications. It speeds up and slows down faster than other robots, saving time while moving between tasks. This is possible due to ABB's patented second generation QuickMove motion control, combined with the robot's strong motors and low friction losses in the spur gears.

No more cutting corners

At high speed, most robots will cut corners. With the IRB 1600, the path will be the same regardless of speed, thanks to the robot's unique combination of brains and brawn. Intelligent second generation TrueMove motion control means that "what-you-program-is-what-you-get". Add muscle – a heavy and stiff design – low vibrations and low friction – and you have a robot that will deliver consistently high work piece quality, high yield and few rejects.

Outstanding reliability

The IRB 1600 offers outstanding reliability, even in the toughest environments and the most demanding 24/7 duty cycles. The entire manipulator is IP 54 classed and sensitive parts are IP 67 classed as standard.

The optional protection Foundry Plus offers IP 67, special paint, rust protection and is tailor made for tough foundry environments. The rigid and heavy design combined with spur gears, make the robot extremely robust. Smart collision detection software further adds to the robot's outstanding reliability.

Easy to integrate

Mounting is fully flexible: on a shelf, on the wall, tilted or inverted. By choosing the compact short-arm version with the 1.2 m reach, you can even fit the IRB 1600 inside a machine, while ensuring sufficient payload as the maximum total load is as high as 36 kg. Sustainable and healthy Low friction spur gears, and no unnecessary moves due to QuickMove and TrueMove, reduces power consumption down to 0.58 kW at max speed, and even less at low speeds. The airborne noise level of just <70 dB (A) secures a healthy sound environment.

Main applications

- Assembly
- Arc Welding
- Material Handling
- Machine Tending
- Material Removal
- Cleaning/Spraying
- Dispensing
- Packing

Specification

Robot version	Reach (m)	Payload (kg)	Armload (kg)
IRB 1600-6/1.2	1.2	6	30.5
IRB 1600-6/1.45	1.45	6	30.5
IRB 1600-10/1.2	1.2	10	20.5
IRB 1600-10/1.45	1.45	10	20.5
Number of axes	6+3 external (up to 36 with MultiMove)		
Protection	Standard IP54 Option FoundryPlus 2 (IP67)		
Mounting	Floor, wall, shelf, tilted, inverted		
Controller	IRC5 Single Cabinet, Compact, OmniCore C30, C90XT, V250XT, V400XT		

Performance (according to ISO 9283)

	Position repeatability	Path repeatability
IRB 1600-6/1.2	0.02 mm	0.13 mm
IRB 1600-6/1.45	0.02 mm	0.19 mm
IRB 1600-10/1.2	0.02 mm	0.06 mm
IRB 1600-10/1.45	0.05 mm	0.13 mm

Technical information

Electrical Connections

Supply voltage	200-600 V, 50-60 Hz
Energy consumption	0.58 kW

Physical

Robot base	484 x 648 mm
Robot height	
IRB 1600-6/1.2	1069 mm
IRB 1600-10/1.2	1069 mm
IRB 1600-6/1.45	1294 mm
IRB 1600-10/1.45	1294 mm
Robot weight	250 kg

Environment

Ambient temperature for mechanical unit	
During operation	+ 5°C (41°F) to + 45°C (113°F)
During transportation and storage	- 25°C (- 13°F) to + 55°C (131°F)
During short periods (max. 24 h)	up to + 70°C (158°F)
Relative humidity	Max. 95%
Safety	Double circuits with supervisions, emergency stops and safety functions, 3-position enable device
Emission	EMC/EMI shielded

Data and dimensions may be changed without notice.

Movement

Axis movement	Working range IRB 1600-6/1.2, IRB 1600-10/1.2	Working range IRB 1600-6/1.45, IRB 1600-10/1.45
Axis 1 rotation	+180° to -180°	+180° to -180°
Axis 2 arm	+110° to -63° +136° to -63° ¹	+120° to -90° +150° to -90° ²
Axis 3 arm	+55° to -235°	+65° to -245°
Axis 4 rotation	Default: +200° to -200° Max. rev: +190° to -190°	Default: +200° to -200° Max. rev: +190° to -190°
Axis 5 bend	+115° to -115°	+115° to -115°
Axis 6 turn	Default: +400° to -400° Max. rev: +288 to -288	Default: +400° to -400° Max. rev: +288 to -288

¹With axis 1 limited to ±100° ²With axis 1 limited to ±95°

Axis max. speed

	IRB 1600-6/1.2, IRB 1600-6/1.45	IRB 1600-10/1.2, IRB 1600-10/1.45
Axis 1 rotation	150°/s	180°/s
Axis 2 arm	160°/s	180°/s
Axis 3 arm	170°/s	185°/s
Axis 4 rotation	320°/s	385°/s
Axis 5 bend	400°/s	400°/s
Axis 6 turn	460°/s	460°/s

Working range, IRB 1600-6/1.2, IRB 1600-10/1.2

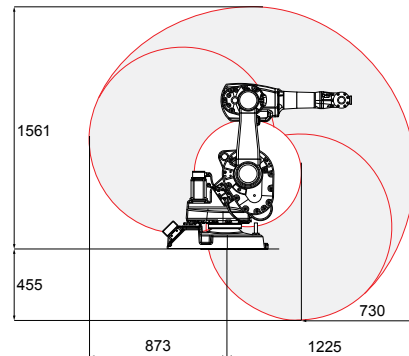

Working range, IRB 1600-6/1.45, IRB 1600-10/1.45

