

SYMPHONY/Harmony Enhanced with Industrial^{IT}

The Enterprise Management & Control System
for Optimizing Process & Business Operations



ABB

Reaching New Levels of Productivity

Within ABB's new family of integrated software and hardware solutions – collectively known as Industrial IT – the ABB Symphony™ Enterprise Management and Control System offers customers a solid foundation for the addition of new Industrial IT components. Symphony user's of Harmony I/O, control and communication elements retain all the process security and existing configuration value of their new or existing harmony controls while gaining the new and innovative features and strategies fundamental to Industrial IT.

SYMPHONY enhances the real-time sharing of knowledge between related, but divergent, enterprise operations. Fully equipped with an integrated set of decision-making tools, Industrial IT makes it possible for real-time information to be shared – and its value compounded – throughout an organization. The result is better and faster decisions that optimize company assets, whether people, raw material, process, or infrastructure.

Open Architecture for Seamless Integration

Industrial IT applications are designed to be used as stand-alone or integrated solutions, enabling the flexibility to implement the required functions today and the agility to add on as needs evolve. ABB's diligent use of open standards simplifies the task of interfacing with existing automation and information systems, while the proven SYMPHONY progression ensures an additional layer of established investment protection.

The Evolution Continues...

Industrial IT is the latest installment on a greater than 20-year commitment that ABB has honored with its DCS users. The company's pledge of *Evolution through Enhancement* ensures that future advances in system technologies will not compromise the customer's current investments. While other vendors may talk about investment protection, ABB's proven program is truly unique in the industry. All told, from the introduction of Network 90 in 1980, through each of the evolution steps of INFI 90, INFI 90 OPEN and SYMPHONY, to the introduction of Industrial IT, this family of systems represent the largest contiguous installed base of any process automation system in the world – an installed base exceeding USD \$5 billion!

A Global Leader

Today, *Evolution through Enhancement* has expanded to include the latest products and services from the world's largest automation supplier; including instrumentation, analytical devices, meters, robotics, drives, motors, machines, manufacturing execution systems, and control products and systems. Backed by common Industrial IT technology and industry specific expertise, ABB's automation portfolio provides the seamless link between process and business management to deliver knowledge-based solutions.

IndustrialIT

today

symphony

1997

**Bailey
infi 90**
OPEN

1994

**Bailey
infi 90**

1988

**Bailey
network
90**

1980

evolution
through
enhancement

Two Decades of Enhancements

Making real-time business decisions to prevent or limit process upsets requires a consistent infrastructure for data, operations, configuration, and maintenance across the entire enterprise. The foundation of this consistent infrastructure is ABB's Aspect Object™ technology provided by the Aspect Integrator Platform (AIP) component. Every

Industrial IT software product is based upon the AIP component. Symphony Harmony fully participates in an integrated Industrial IT environment by leveraging the full power of the Aspect Object technology by employing an open, enterprisewide architecture that supports a seamless communications fabric to every level of control – from field I/O to

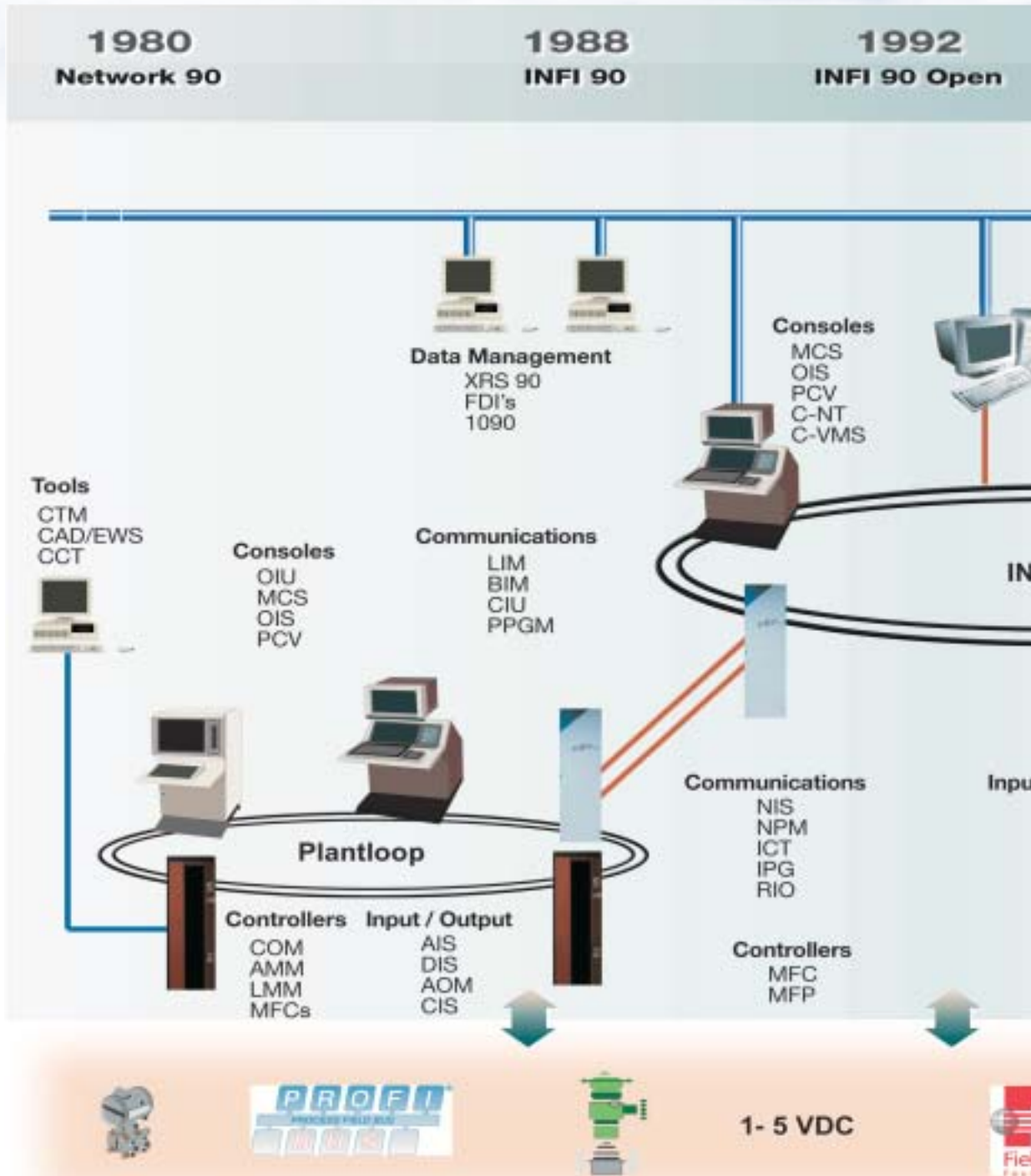

plantwide and multi-plant systems. SYMPHONY Harmony essential security and proven availability at the control level are integrated with enterprise network strategies for total enterprise communication.

The scalable SYMPHONY Harmony architecture allows for easy integration of ABB Industrial IT components, such as Operate

IT, Produce IT, Inform IT, and Optimize IT. In addition, non-traditional DCS functional areas, such as field device management and PLC controls, simply “plug-and-produce” in the SYMPHONY Harmony architecture via other ABB Industrial IT components, such as Engineer IT and Control IT.

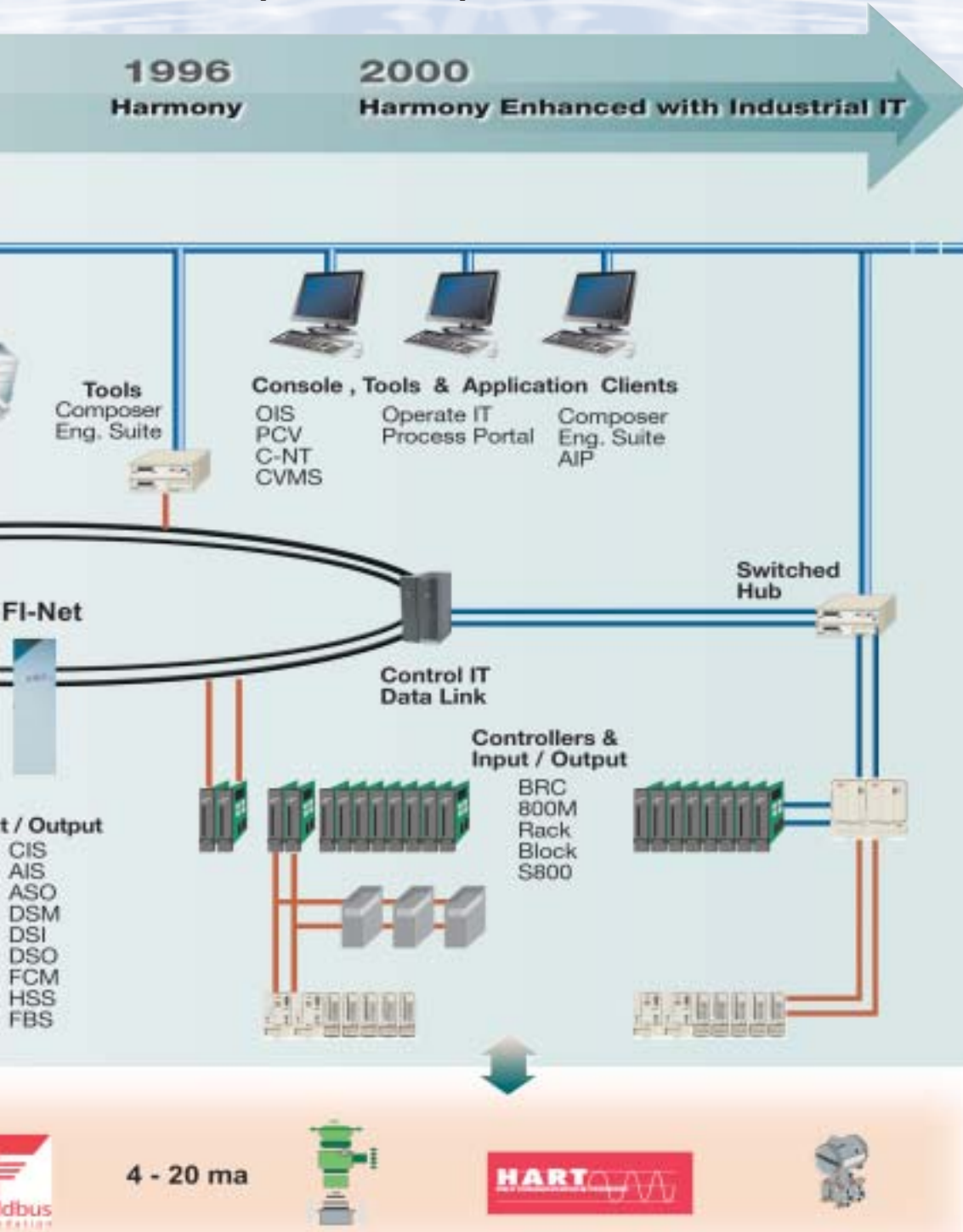

Powerful Tools

for Enterprise Management and Control

ABB's Industrial IT with SYMPHONY solutions reach beyond the traditional boundaries of distributed control systems to support the platform, application and professional service needs of total enterprise management and control.

SYMPHONY's multi-tiered span of control provides a secure foundation with robust, but flexible, base level regulatory and sequence control. Solutions continue through the full range of higher level management and advanced control functions to include: production management, maintenance management, simulation, historian, and network management. The integration of these powerful features is achieved through SYMPHONY's integrated "plant-centric" architecture. Embodied in the principles of open, real-time networking, the SYMPHONY architecture provides a scalable communications fabric that spans and integrates loop, unit, area, plant, and interplant controls.



Industrial IT with SYMPHONY dramatically improves enterprisewide productivity through four powerful, integrated classes of products:

Harmony Series Area Management and Control Products – a comprehensive set of traditional process, regulatory and sequence control services and I/O interfaces

Composer Series System Engineering Tools – an integrated suite of engineering and maintenance tools designed to support the complete automation project, including planning and data acquisition, configuration management, library management, commissioning, and operation

Operate IT-Process for Harmony and other Human System Interfaces – a range of console products for accessing and viewing data from multiple operating environments, from process control and I/O to plant and enterprise information

Industrial IT Plant Optimization and Management Solutions – a powerful suite of products and services for plant management and control focused on increasing asset utilization and on optimal management of plant capacity



**Plant Optimization
& Management**



**Engineering, Operation
& Maintenance Tools**



**Human System
Interfaces**



**Area Management
& Control**



Control Products



The Harmony product series consists of a family of process controllers, communication couplers and I/O interfaces. Thirty-two bit processing, coupled with modular scalability, make the Harmony family a powerful and versatile performer.

Harmony Controllers feature an extensive library of over 240 pre-defined advanced control algorithms and user-definable functions. These functions provide the power to easily design complex control strategies to fit any control application, including continuous, sequential, batch, and advanced control. In addition to standard "function code" implementation, Harmony Controllers support batch language, "C" programming and even multi-variable control. Available in both rack and block packaging, the multifaceted Harmony Controllers communicate simultaneously with numerous field communication protocols.

Harmony I/O, available in rack and remote form factor options, provide a wide variety of input/output and signal conditioning capability, ranging from standard analog and digital I/O to specialty I/O like turbine control and fieldbus. Modular I/O packaging options and high speed field communications allow for remote I/O distances in excess of 2KM. Redundant I/O, at the channel level, redundant power and redundant communications provide the highest level of I/O availability in the DCS industry.

SYMPHONY'S control products support ABB's *Evolution through Enhancement* strategy by providing backward compatibility with Bailey Network 90, INFI 90 and INFI 90 OPEN systems and can execute all multi-function processor (MFP) operations. Also, the addition of Industrial IT components, when used for non-traditional DCS plant control applications such as AC800 for motor controls and remote terminal unit (RTU) operations, complement the Harmony family of products. Data exchange between these areas of control is facilitated at both the controller and human system interface (HSI) level.



Operator Interface

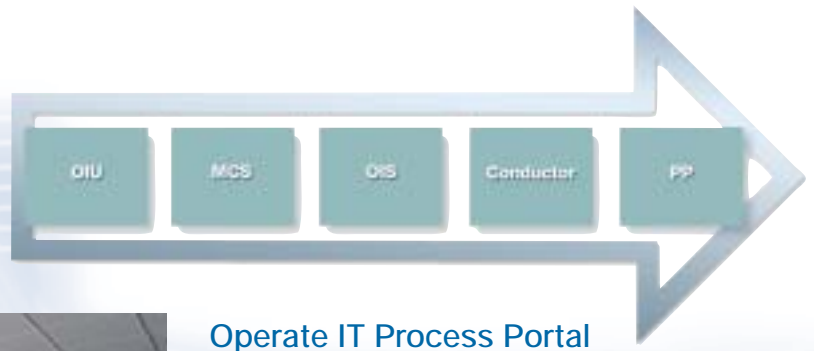

Conductor Series

Conductor provides an incremental series of platforms for HSI that complement the inherent functionality of the control system with the basic suite of operator directed features and functions. These versatile features and functions are ergonomically designed to facilitate process monitoring, control, fault mitigation, and optimization. They offer more than just a way for operators to interact with machines. They provide system users with expanded dynamic access to *all* plantwide or enterprisewide information through open system connectivity.

Operate IT Process Portal

Process Portal is a feature rich, web-enabled HSI designed as a native Windows-based product. A managed Windows workplace within a web browser environment supports its users with intuitive navigation and compatible integration with other ABB and third party web-enabled applications, allowing users to efficiently access and monitor information flow through the control system, the process, the plant, and the entire enterprise.

Providing the versatility needed to meet ever changing operational and process needs, Operate IT supports custom navigational toolbars and user profiles for defining appropriate workspace behavior. Operate IT supports the full spectrum of plant and enterprise personnel needs including graphical user interface, process data collection, storage and analysis tools, an advanced alarm management system, a comprehensive historian, and an advanced reporting package. As part of an open system, Operate IT embraces OPC™ to provide a standard interface method with third party devices, and incorporates OPC client and OPC server connectivity.

Aspect Objects

Process Portal provides all of the traditional human system interface functionality such as event and alarm management, custom graphic displays, faceplate and tuning displays, trending, and reporting. Through the use of ABB's unique Aspect Object™ technology, Process Portal provides integrated information access and sharing, intuitive navigation and efficient engineering. An Aspect Object represents a physical or logical part of the automation installation, such as a valve, pump or actual batch, but also process units or combinations of hardware units. All information, or aspects, belonging to those objects is structured in functional windows called aspect views. Examples of aspects are historical data, process signal data or technical specifications.

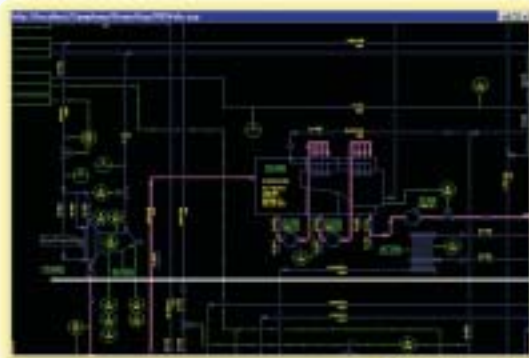

CAD specifications

Word documentation



Data tags



Operators gain the advantage of single-click access to information-rich aspect views...



ERP interfaces



PDF technical documentation

Data Management

To achieve true enterprise automation, Industrial IT with SYMPHONY components go beyond traditional process control to tightly integrate both control and management functions from the plant floor to the executive staff. To achieve this increased span of control, ABB offers a suite of plant management and control products, ranging from plant information management to plant optimization applications.

Industrial IT plant management and control products improve enterprise productivity by:

- Providing secure, tightly integrated base regulatory and sequential controls
- Scaling advanced control across a range of technologies
- Facilitating process information propagation throughout the enterprise
- Providing for both adaptive and predictive decision support practices
- Supporting E-commerce and B2B strategies with real-time enterprise data
- Imparting protected web access when and where appropriate

Advanced Control for Increased Efficiency

Advanced control packages provide optimum production management solutions. From multi-variable control applications at the controller level to enterprise spanning Pavilion solutions, Industrial IT delivers a foundation for advanced control techniques in real-time. Backed by industry specific experience and know-how, Industrial IT advanced control applications designed to insure that plants will operate more efficiently, profitably and competitively.

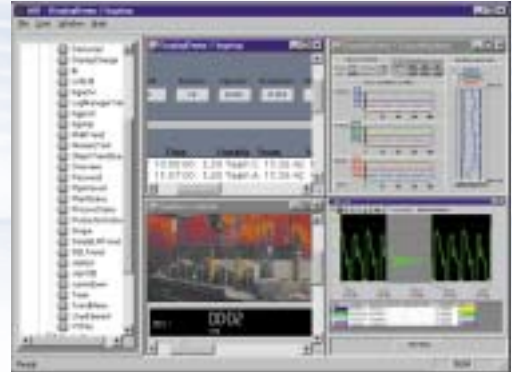

Inform IT

Inform IT is the key element of information management. Information management is essential for understanding asset performance and designing procedures for optimizing assets over their life cycles. With Inform IT, users increase engineering efficiency by working in a flexible distributed environment offering both high data security and remote access. The platform provides tools to capture, archive, model, and analyze data to create informative reports and to make better decisions.

ABB provides industry specific extensions of Inform IT – such as profile and contour visualization for paper and flat sheet processing – as well as other applications where quality gauging systems are required.

Process Information Web Server (PIWS) supports controlled intranet information access across the enterprise. PIWS can assist customers who have a constant need for process information and status as well as customers with temporary requirements.



Optimize IT

Optimize IT's advanced optimization solutions address the need for real-time economic optimization in the multi-period, multi-plant enterprise.

Asset Optimization includes integration of field instruments to the control system via fieldbus protocols, maintenance triggers, interfaces with maintenance management systems, documentation management, and audit trails

Process Optimization provides the means to create and manage process models that have been optimized using a range of solutions. This allows users to address yield accounting, waste, safety, regulatory compliance, and economic issues

Dynamic Simulation and Training assists operator training and certification and aids with design validations

Supply Chain Optimization includes integrated planning, scheduling and utilization algorithms and decision tools for production of specified component quality and quantity to support E-commerce requirements



Produce IT

Produce IT provides batch production management solutions, delivering unsurpassed batch-to-batch consistency, quality and productivity. These measurable results are achieved through an unmatched level and scope of batch control integrated with scheduling, electronic batch records, HSI, history, and controllers. Whether a process is manual, automated or both, Produce IT offers solutions for stand-alone environments or for integrated operation with ERP, DCS, etc.

Linking Process Control with Enterprise Management

Enterprise Production Management Software capabilities permit facilities to link process control with enterprise management and other information systems to support regulatory compliance and collaborative commerce, facilitate decision-making and permit optimal capacity utilization and supply chain management. Offerings are available for both Windows and UNIX platforms.

These Industrial IT optimization technologies can be added to a customer's SYMPHONY system today, helping to achieve the competitive advantage necessary to operate in the dynamic global marketplace. ABB leverages its expertise in various industry segments to offer customized optimization applications and products to power utilities, water and wastewater, pulp and paper, chemical processing, hydrocarbon processing, and other industrial markets.

Global Support & Services

As a leading global provider of industrial asset and optimization services for power and automation systems, ABB maintains a unique position to offer innovative and diverse solutions for improved facility performance and effective maintenance systems management. With an unparalleled scope of automation products, systems and services, we provide performance-based service packages that increase production, reduce maintenance costs and improve return on existing assets.

Asset Management Services

ABB Asset Management Services move beyond a cost-cutting approach, offering customized performance-based services focused on a specific need, an entire asset classification or complete plant maintenance responsibility. Optimizing asset management through outsourcing designed to deliver improved operation and maintenance effectiveness, helps to deliver a lighter balance sheet and increased cash flow, while providing maximum value and profitability.

Asset Management Services

Consulting Services

- Plant Performance Benchmarking
- Performance Improvement Delivery
- Cultural Change Management
- Sustainable Maintenance Excellence
- Shutdown Excellence
- Safety, Health & Environmental Excellence

Total Equipment Management

- Motor Condition Monitoring
- Drive Management
- Rotating Machine Management
- Instrumentation Management
- Control Systems Management

ABB Full Service

- ABB Full Service™ Partnership Agreements
- Single Shutdown Contracts
- Multiple Shutdown Partnership Agreements

Product And System Services

A wide variety of services are available locally providing total system as well as tailored user support. From complete management services to just-in-time technical support, ABB offers unequalled services for power and automation systems. Our diverse industry and application knowledge acquired through a strong global presence can benefit your operation through improved overall performance, increased uptime and reduced costs.

Product and System Services

Customer Support Services

24x365

- Hardware/Software
- Contract & Demand
- Web, On-line & Remote Services
- Telephone Services
- Upgrades, Expansions & Modifications

Training Services

- ABB Product Training
- Process & Application Training
- General Technology Training
- Training Contracts
- Training Assessment Programs

Parts & Repair Services

- Parts Services
- Reconditioning & Repair Services
- Version Management
- Legacy Product Support
- Parts Management Support

Application Services

- Installation & Commissioning
- Product Application Services
- Product Environmental Adaptation Support
- Process Application Services
- Product Migration Services



Evolution Services

StepUp

StepUp Programs provide a cost effective means to migrate to the latest ABB products and help position your automation system for new technology as it becomes available.

This allows you to continuously evolve your system to higher levels of control, operations, information management, and connectivity.

SoftCare

The SoftCare software management program continuously provides you with immediate access to the latest productivity enabling software. In keeping your software current, SoftCare positions you for the constantly changing industry and IT standards by providing constant enhancements, better integration, and more efficient support.

Conversion Services

In development of new products, it has always been ABB's philosophy and commitment to provide an evolution path for the installed base. We continue with that commitment by providing conversion and interface services that assist in graceful migration.

These services help simplify the evolution process, reduce engineering cost, reduce installation time, and reduce risk.





**For additional information,
visit us on the Internet at www.abb.com/controlsystems**



ABB Inc.
29801 Euclid Avenue
Wickliffe, Ohio 44092
Phone: +1 440 585-8500
Fax: +1 440 585 8756
www.abb.com/controlsystems

ABB AB
SE-721 59 Västerås, Sweden
Phone: +46 (0) 21 34 2000
Fax: +46 (0) 21 13 78 45
www.abb.com/controlsystems

ABB GmbH
Dudenstraße 44-46, D-68167
Mannheim, Germany
Phone: +49 (0) 1805 266 776
Fax: +49 (0) 1805 776 329
www.abb.com/controlsystems

Copyright © 2003 by ABB Inc. All rights to trademarks reside with their respective owners.

Specifications subject to change without notice. Pictures, schematics and other graphics contained herein are published for illustration purposes only and do not represent product configurations or functionality. User documentation accompanying the product is the exclusive source for functionality descriptions.