

UniSec Installation manual

Safety	3
For your safety!	3
Skilled personnel	3
Crucial information	3
Contact us!	3
1. Introduction	4
1.1 General aspects	4
1.2 Installation manual	4
2. Product information	5
2.1 Unit dimensions	5
2.2 Weights	8
3. Transport and storage	9
3.1 Condition on delivery	9
3.2 Unpacking at installation site	9
3.3 Handling the units as far as the installation site	10
3.4 Temporary storage	12
3.5 Delivery responsibilities	12
4. Assembly of the switchgear on site	13
4.1 General warnings and cautions	13
4.2 Preparations	13
4.3 Dimensional foundation drawings	13
4.4 Foundations	22
4.5 Installation procedure for units	22
4.6 Gas vent ducts	33
4.7 Coupling to panels with withdrawable circuit-breaker and switch-disconnector (GSec)	37
5. Cable connections	38
5.1 Installing the cables	38
5.2 Control cables	44
5.3 Earthing the switchgear	44
5.4 Final installation work	45
A. Tightening torques for steel screws and nuts/bolts	46
B. Tools required for installation	49



Safety

For your safety!

- Strictly follow this manual.
- Only install switchgear in indoor conditions suitable for electrical equipment.
- Ensure that installation, operation and maintenance is only carried out by professional electricians.
- Comply fully with the standards in force (IEC or local), the connection conditions of the local power utility and the applicable safety at work regulations.
- Observe the relevant information in the manual for all actions involving the switchgear.
- For use of the circuit-breaker, refer to the instruction booklet.

Skilled personnel

All the installation, putting into service, running and maintenance operations must be carried out by skilled personnel with in-depth knowledge of the apparatus.

When carrying out any maintenance work, the regulations in the country of installation must be strictly complied with.

Maintenance work must only be performed in a professional way by trained personnel familiar with the characteristics of the switchgear, in accordance with all the relevant IEC safety regulations and those of other technical authorities, also respecting other overriding instructions. It is recommended that ABB service personnel be called in to perform the servicing and repair work.

Crucial information

Pay special attention to the information shown in the manual by the following symbol:



After this symbol there are four different indications which explain the possible type of injuries or damage which may be caused when the instructions, including recommended safety precautions, are not followed.

- **DANGER** - identifies the most serious and immediate hazards which can result in serious personal injury or death
- **WARNING** - identifies hazards or unsafe practices which can result in serious personal injury or death
- **CAUTION** - identifies hazards or unsafe practices which can result in minor personal injury or product or property damage
- **NOTE** - identifies important procedures or requirements that, if not followed, can result in product or property damages



WARNING

Make sure that the specified electrical ratings are not exceeded under switchgear operating conditions. Keep the manuals accessible to all personnel involved in installation, operation and maintenance. The user's personnel are responsible for all matters regarding safety in the workplace and correct use of the switchgear.



WARNING

Always follow the instructions in the manual and respect the rules of good engineering practice (GEP)! Hazardous voltages can cause serious injury or death! Disconnect the power and earth live parts before proceeding with any work on the apparatus. Follow the safety regulations in force in the place of installation.

Contact us!

If you have any further questions about this manual, our field service team will be pleased to help. See the backside of this manual for contact information.

1. Introduction

1.1 General aspects

UniSec is an air-insulated switchgear for indoor use, designed for medium voltage secondary distribution. UniSec switchgear is the result of continuous innovation, following the desire to meet ever-changing market needs.

This new series of switchgear offers a wide range of long-term technical solutions.

Safety, reliability, user-friendliness and simplicity of installation, as well environmental sustainability were the driving forces in developing this switchgear.

UniSec is structured by placing standardized units side by side in a coordinated way. Construction and testing are carried out in the factory.

1.2 Installation manual

This manual provides information on installation of UniSec units. It contains details about product dimensions and weights, as well as instructions for unpacking and delivery to the installation site. Step-by-step instructions show the procedure for installing the switchgear.

2. Product information

2.1 Unit dimensions

Code	Description	Width				
		190 mm	375 mm	500 mm	600 mm	750 mm
SDC	Unit with switch-disconnector		•	•		•
SDS	Unit with switch-disconnector – disconnection		•	•		•
SDD	Unit with double switch-disconnector					•
SDM	Disconnecting unit with measurements with switch-disconnector					•
UMP	Universal measurement unit					•
DRC	Direct incoming unit with measurements and busbar earthing		•	•		
DRS	Riser unit – measurements		•	•		
SFV	Switch-disconnector with fuse – measurements			•		
SFC	Switch-disconnector unit with fuses		•	•		•
SFS	Switch-disconnector with fuses – disconnection		•	•		
SBC	Circuit-breaker unit with switch-disconnector					•
SBC-W	Withdrawable circuit-breaker unit with switch-disconnector					•
SBS	Circuit-breaker unit with switch-disconnector – disconnection					•
SBS-W	Withdrawable circuit-breaker unit with switch-disconnector – disconnection					•
SBM	Disconnection unit with measurements with circuit-breaker and double disconnector					•
SBR	Inverted circuit-breaker unit					•
HBC	Unit with integrated circuit-breaker and switch-disconnector			•		
RLC/RRC	Right and left side cable riser (for SBR units only)	•				
WBC	Unit with withdrawable circuit-breaker				• (*)	• (**)
WBS	Unit with withdrawable circuit-breaker – disconnection				• (*)	• (**)
BME	Busbar earthing and measurement unit				• (*)	

□ 12-17,5 kV

□ 24 kV

Side view of the different LSC2A units

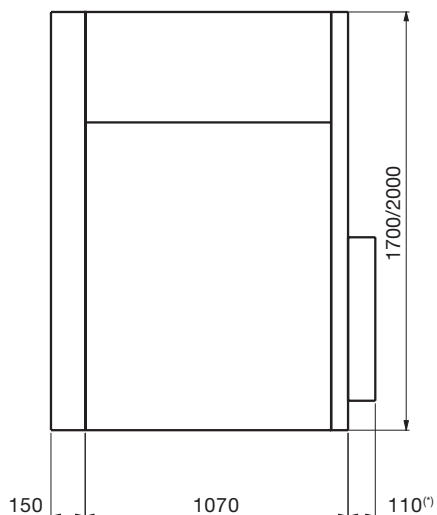

□ For panels with removable circuit-breakers

Figure 1. Side view of IAC A-FL 12.5 kA 1s (solution installed completely against a wall)

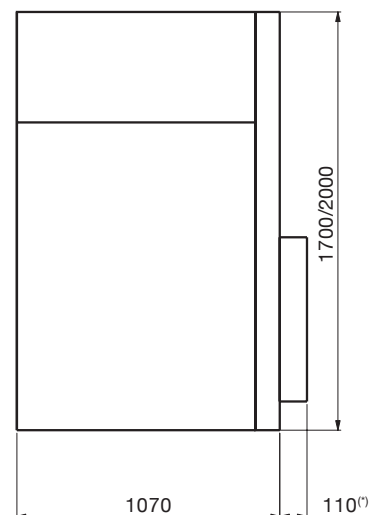

□ For panels with removable circuit-breakers

Figure 2. Side view IAC A-F 16 kA 1s (solution completely against the wall)

Side view of the different LSC2A units

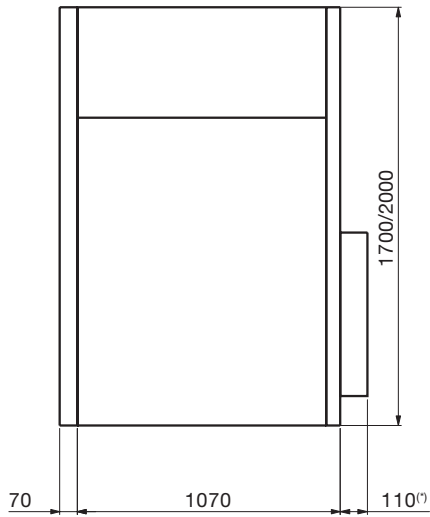

⁽¹⁾ For panels with removable circuit-breakers

Figure 3. Side view IAC A-FL 12.5 kA, with filters

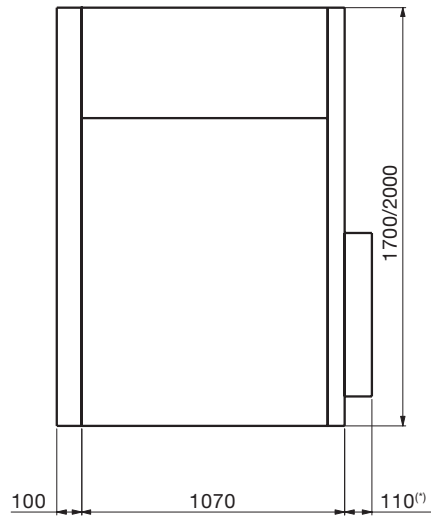

⁽¹⁾ For panels with removable circuit-breakers

Figure 4. Side view IAC A-FLR 16 kA, with filters

Side view of the different LSC2B units

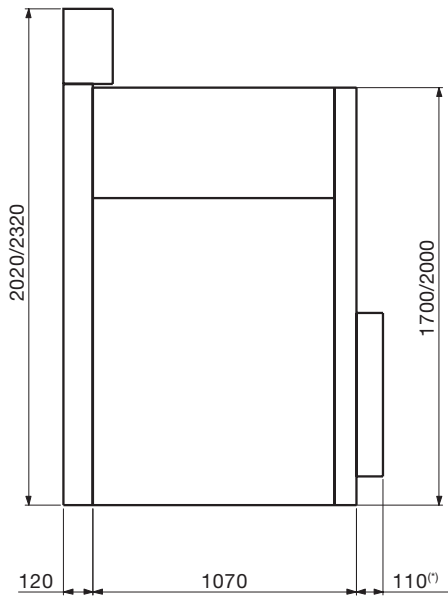

⁽¹⁾ For panels with removable circuit-breakers

Figure 5. Side view IAC A-FLR 21 kA, with duct

WBC
WBS
DRS for WBS

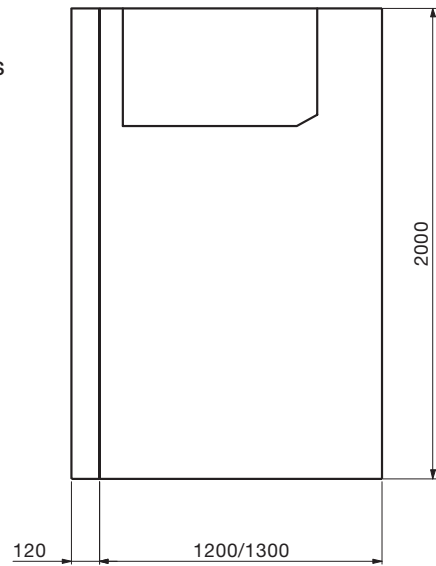

Figure 6. Side view for panels with withdrawable circuit-breakers, IAC A-FLR 25 kA, 1 sec up to 17.5 kV and IAC A-FLR 16 kA, 1s at 24 kV with filters

Side view of the different LSC2B units

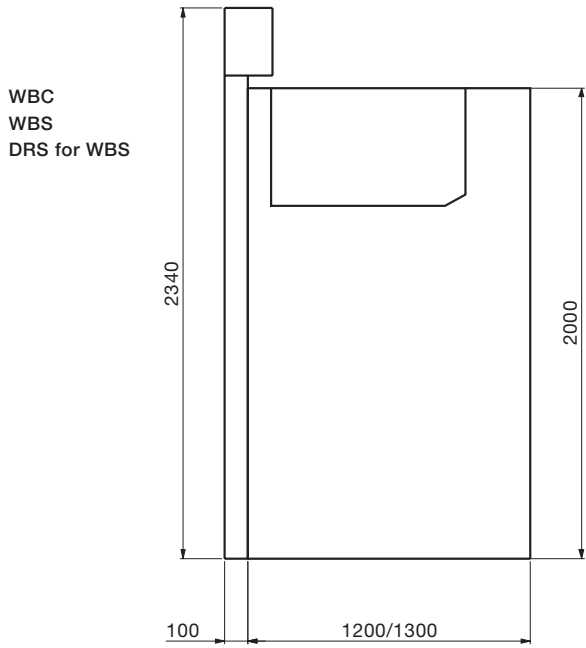

Figure 7. Side view for panels with withdrawable circuit-breakers, IAC A-FLR 25 kA, 1 sec up to 17.5 kV and IAC A-FLR 21 kA, 1s at 24 kV with duct

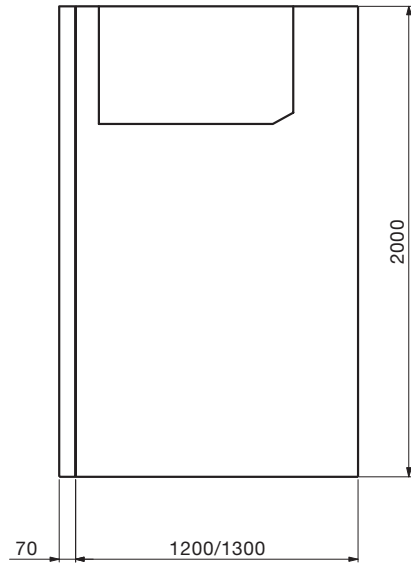

Figure 8. Side view for panels with withdrawable circuit-breaker IAC A-FL 12.5 kA 1s with filters

Side view

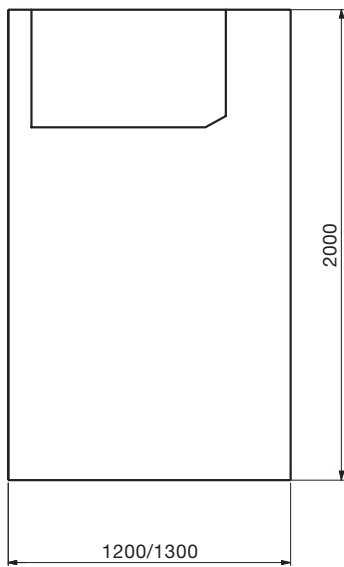

Figure 9. Side view for panels with withdrawable circuit-breaker IAC A-FL 12.5 kA 1s (solution installed completely against a wall)

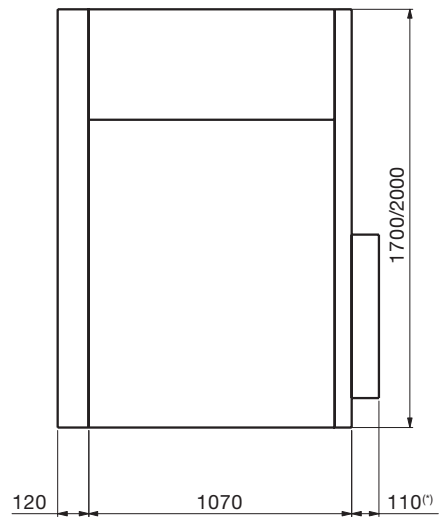

Figure 10. Side view of IAC AFLR 21kA x 1s - Downward

2.2 Weights

The following table shows the maximum weights of the different units.

Weights are indicative, without CTs, VTs and fuses.

For further information please contact ABB.

Unit	Panel width mm	Panel width	
		1700 mm kg	2000 mm kg
SDC	375	150 ⁽¹⁾	160 ⁽¹⁾
	500	170 ⁽¹⁾	180 ⁽¹⁾
	750	195 ⁽²⁾	210 ⁽²⁾
SDS	375	155 ⁽²⁾	165 ⁽²⁾
	500	175 ⁽²⁾	185 ⁽²⁾
	750	200 ⁽²⁾	215 ⁽²⁾
SDM	750	230 ⁽²⁾	250 ⁽²⁾
SDD	750	270 ⁽²⁾	290 ⁽²⁾
UMP	750	200 ⁽²⁾	–
SFC	375	155 ⁽³⁾	160 ⁽³⁾
	500	175 ⁽³⁾	185 ⁽³⁾
	750	200 ⁽³⁾	215 ⁽³⁾
SFS	375	165 ⁽³⁾	175 ⁽³⁾
	500	180 ⁽³⁾	190 ⁽³⁾
SBC	750	355 ⁽²⁾	355 ⁽²⁾
SBC-W	750	355 ⁽²⁾	355 ⁽²⁾
SBS	750	355 ⁽²⁾	375 ⁽²⁾
SBS-W	750	355 ⁽²⁾	375 ⁽²⁾
SBM	750	390 ⁽²⁾	410 ⁽²⁾
SBR	750	335 ⁽²⁾	–
HBC	500	250 ⁽²⁾	275 ⁽²⁾
SFV	500	175 ⁽²⁾	185 ⁽²⁾
DRC	375	120 ⁽²⁾	130 ⁽²⁾
	500	135 ⁽²⁾	145 ⁽²⁾
DRS	500	–	–
WBC	600	–	600 ⁽¹⁾
	750	–	750 ⁽¹⁾
WBS	600	–	600 ⁽¹⁾
	750	–	750 ⁽¹⁾
BME	600	–	450 ⁽¹⁾

⁽¹⁾ Without CT

⁽²⁾ Without CT or VT

⁽³⁾ Without fuses

Table 1. Maximum weights of units

3. Transport and storage

3.1 Condition on delivery

Delivery packing

UniSec is delivered either as a single unit or in multiple switchgear units with a length of no more than 2.0 m, and with the doors closed. The size of the pack(s) depends on the number and type of units and has to be defined separately in each case.

The factory-assembled units have been inspected by the manufacturer in the factory for completeness in terms of the order and, at the same time, subjected to routine testing according to IEC publication 62271-200 in order to verify correct construction and functions.

The branch busbars are factory-assembled for each unit. However, the main busbar connections between different units must be carried out on site. The main busbars and their accessories are packed separately for delivery.

3.2 Unpacking at installation site

Storage and inspection

The UniSec switchgear must only be installed indoors. It is therefore important to store the switchgear units in their transport packing for as long as possible. Do not store switchgear units outside.

The packs should only be opened to inspect for any damage caused during transport. After inspection, the packing should be restored to its original condition.



NOTE
Any transport damage must be reported to the carrier/forwarder immediately. If installation of the switchgear is to be made immediately after delivery, the transport packing must be removed, except for the plastic vapour corrosion inhibitor film covering the units, which must only be removed at the final switchgear installation site.

Unpacking

The UniSec units are fixed to the pallet using separate fixing plates (2 plates on the back of the unit) and bolts (2 bolts on the front of the unit) inside the unit.

- a) Remove the plastic film from the units.
- b) Take off and dispose of the fixing plates and bolts as these will not be needed.
- c) The table shows a list of the packing materials used for the switchgear units and their possible recycling methods. Packing materials may vary from case to case. The list gives an indication of the possible packing materials.

Packing materials

Table 2. lists all the packing materials used in the switchgear:

Raw material	Possible recycling method
Plywood	Recycling or disposal
Unplaned wood products	Recycling or disposal
Antistatic polythene film	Recycling or disposal
Polythene shrink wrap	Recycling or disposal
VCI (vapour corrosion inhibitor) film	Recycling or disposal
Tape	Recycling or disposal
Folded cardboard and polystyrene reinforcements	Recycling or disposal
Corner protections	Recycling or disposal

Table 2. Packing materials

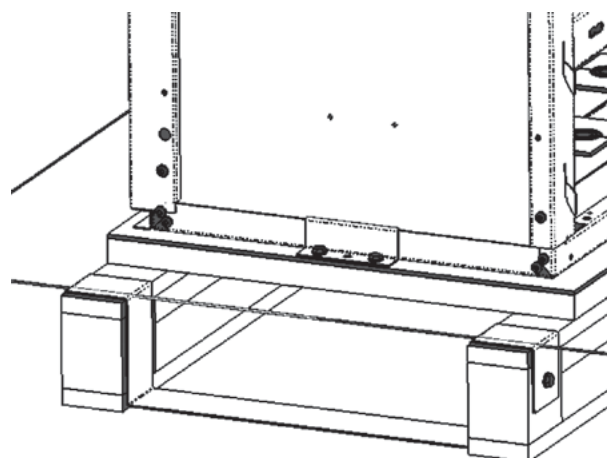

Figure 11. Fixing plates outside the 375-500 mm unit

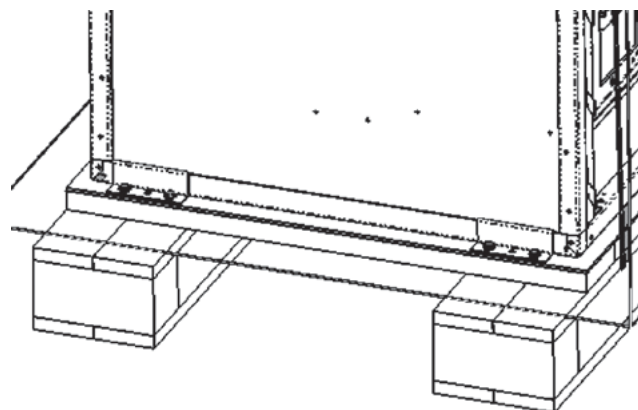

Figure 12. Fixing plates outside the 750 mm unit

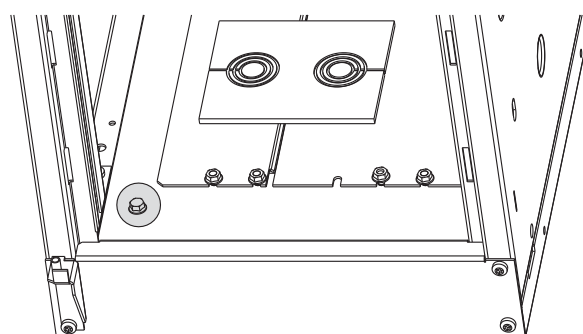

Figure 13. Bolt inside the unit (left side)

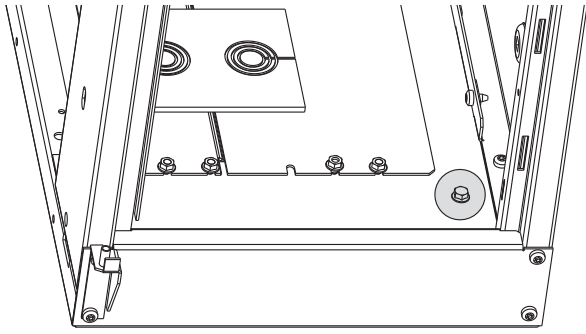

Figure 14. Bolt inside the unit (right side)

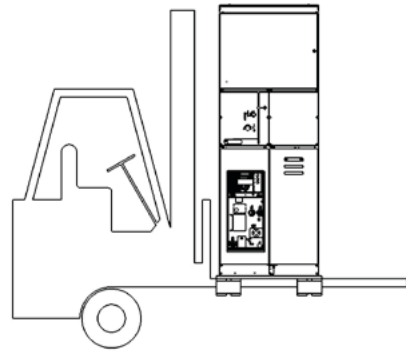

Figure 15.

3.3 Handling the units as far as the installation site

3.3.1 General warnings and cautions



DANGER

Only carry out loading operations when it has been ensured that all precautionary measures to protect personnel and materials have been taken.



CAUTION

The switchgear units should usually be handled in an upright position. Take the high centre of gravity into account. Tilting or overturning must be avoided. If necessary, single units can be carried horizontally, for example, because of a low doorway. In such cases, the unit must be supported over a wide area.

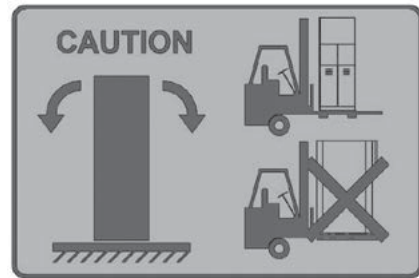

Figure 16.

If a crane is available, lifting can be done by using the lifting hooks which are delivered separately. The lifting procedure, including how to install the lifting hooks, is illustrated on the right.



NOTE

It is also possible to move units on a flat floor to the installation site by using rolling tubes. The rolling tube dimensions should be about 1 m in length and 20-25 mm in diameter.

3.3.2 Instructions

Transport units

The transport units consist of individual units or small groups of units. The lifting hooks are suitable for all UniSec units (375 mm, 500 mm, 600 mm and 750 mm).

Handling instructions

The units must be handled in the upright position using a manual forklift or a forklift truck or, exceptionally, using special rolling tubes (at least four).



CAUTION

The packages should be placed on a level surface.

Lifting instructions

Use the following tools for lifting:

- Crane
- Fork-lift truck and/or.

3.3.3 Lifting procedure

Parts

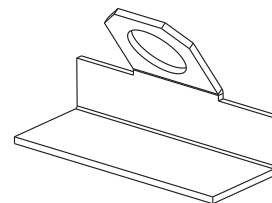

Figure 17. Lifting hook

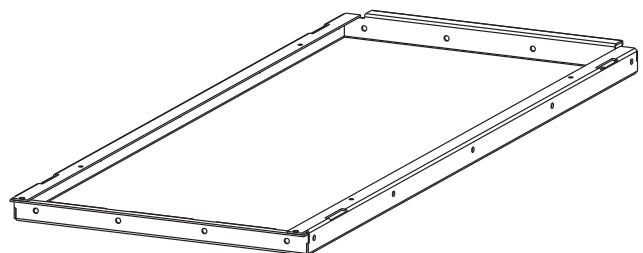

Figure 18. Roof frame on the top of the unit

Operations to be carried out before lifting

a) Install the lifting hooks on the roof frame.

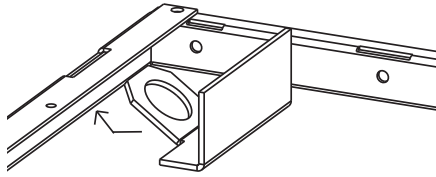

Figure 19. Roof frame + lifting hooks

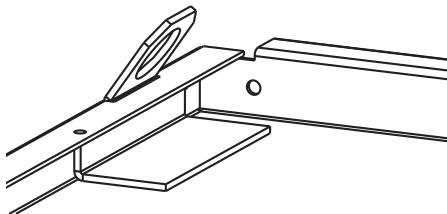

Figure 20. Lifting hooks installed on roof frame

b) Repeat the operation for all four corners of the roof frame.

Switchgear ready for lifting: lifting hooks installed

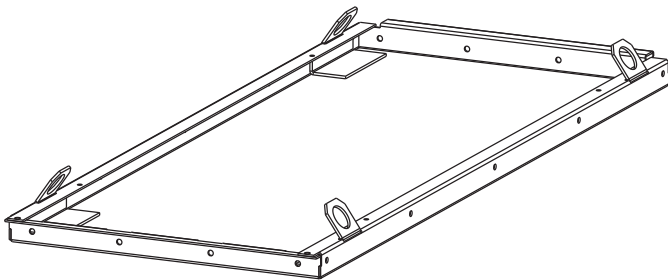

Figure 21. 375 mm, 500 mm and 600 mm UniSec units

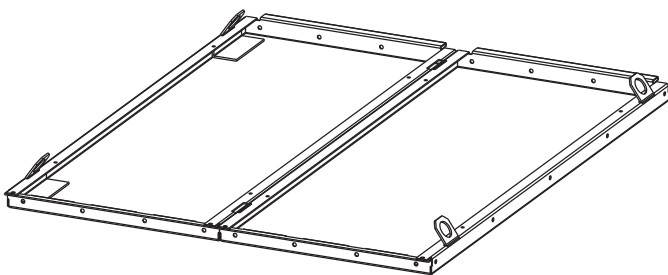

Figure 22. 750 mm UniSec unit

Lifting dimensions and angle

When lifting using a crane, proceed as follows:

- Fit lifting ropes of an appropriate load capacity with spring catches.
- Keep an angle of at least 60° between the horizontal plane and the ropes leading to the crane hook.

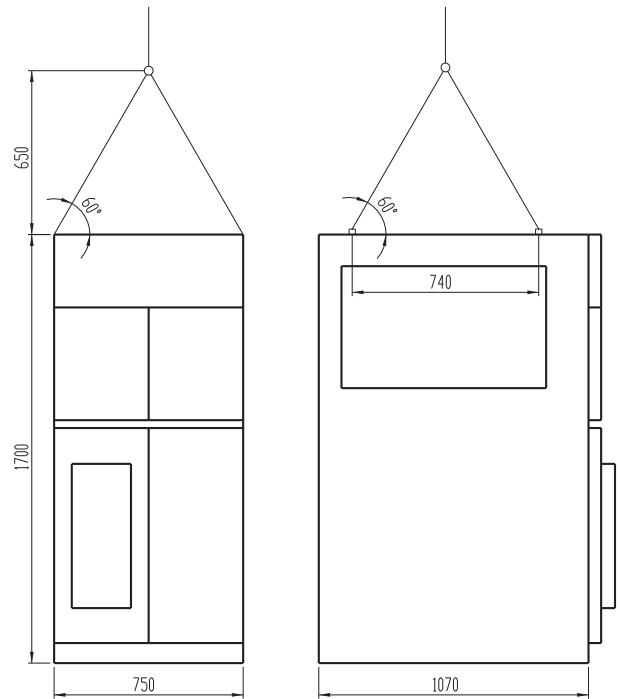

Figure 23. Dimensions and angles



CAUTION

Four lifting ropes of sufficient length must be used when lifting several units or a whole switchgear (4 units at the most, or a maximum length of 2 m).

Lifting by crane

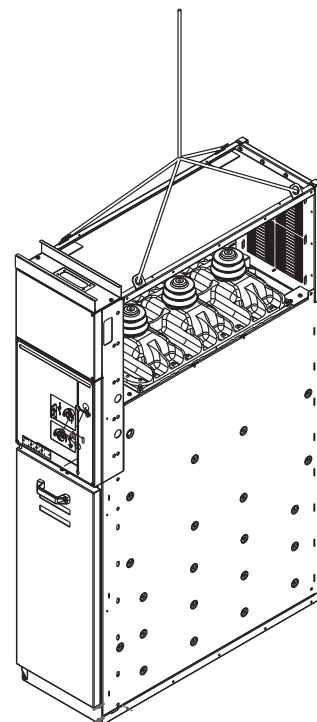

Figure 24. Lifting

Operations after lifting

- Dismantle the lifting hooks.
- The same hooks are used again for the next unit.

3.4 Temporary storage

3.4.1 General warnings and cautions



CAUTION

The packing must be kept indoors immediately after arrival. The conditions must meet the environmental requirements of the IEC 60721-3-1 Standard, classification 1K3.



CAUTION

The vapour corrosion inhibitors placed in the units for protection against humidity during temporary storage and transport must not be removed until installation is completed.



CAUTION

The duration of the protective effect of the packing is limited to a few months when stored indoors in a dry place. ABB should be consulted in the case of longer storage periods or if the storage conditions differ from those indicated.

3.4.2 Optimum storage conditions

Definition: Optimum temporary storage, without negative consequences, depends on compliance with the minimum requirements for the units and packing materials.

Minimum air temperature	°C	- 5 ⁽¹⁾
Maximum air temperature	°C	+ 40
Minimum relative humidity	%	5
Maximum relative humidity	%	95
Rate of temperature change	°C/min	0.5

⁽¹⁾ For service temperature -25 °C and storage temperature -40 °C, please ask ABB.

Table 3. Climatic conditions according to IEC 60721-3-1, classification 1K3.

Type of packing

Special instructions depending on the type of packing are given below:

1. Units with basic packing or without packing

- 1) Use a dry, well-ventilated place with climatic conditions in accordance with Table 3.
- 2) Store the units upright.
- 3) Do not stack units.
- 4) Units with basic packing:
 - Open the packing, at least partially.
- 5) Units without packing:
 - Cover with non-adherent protective sheeting.
 - Ensure there is sufficient air circulation.
 - Regularly check for any condensation until installation is started.

2. Units with seaworthy or similar packing with internal protective sheeting

- 1) Store the transport units:
 - protected from the weather,
 - in a dry place,
 - safe from any damage.
- 2) Check the packing for any damage.

3.5 Delivery responsibilities

Responsibilities

The responsibilities of the consignee when the switchgear arrives on site include, but are not limited to, the following:

- Checking the consignment for completeness and lack of any damage (e.g. for signs of humidity and its detrimental effects). In case of doubt, the packing must be opened and then properly resealed.



NOTE

Always take photographs to document any major damage.

- The packing list includes any separate additional material (not installed). This material can often be found in the first unit of the switchgear.

If any quantities are short, or defects or transport damage are noted, these must be:

- Documented on the respective shipping document.
- Immediately notified to the relevant carrier or forwarding agent in accordance with the relative liability regulations.

4. Assembly of the switchgear on site

4.1 General warnings and cautions



WARNING

Once the documents have been prepared for final mounting, the binding data supplied by ABB must always be taken into account!



WARNING

In order to obtain an optimal installation sequence and ensure high-quality standards, on-site installation of the switchgear must only be carried out by specially trained and skilled personnel, or at least by personnel supervised and monitored by competent and responsible people.



NOTE

Where switchgear units have roof-mounted gas vent ducts or large auxiliary circuit compartments, it must be ensured that the ceiling height is sufficient for these.



ATTENTION

The access to the Swg Room while Swb is in service is permitted to authorized personnel only who has specific expertise on electrical safety according to CEI 11-27 or IEC/EN 50110.

4.2 Preparations

Before starting

To commence installation on site, the switchgear room must be absolutely suitable, i.e. provided with lighting and electricity, fitted with a padlock, ventilation facilities and must also be dry. All the necessary preparations, such as wall openings, ducts, etc. for laying the power and control cables as far as the switchgear, must already have been completed.

Before proceeding with installation:

- a) Clean the installation site
- b) Visibly trace the perimeter of all the units making up the switchgear on the slab, taking the minimum clearances of wall and any obstacles into account.

4.3 Dimensional foundation drawings

4.3.1 Room layout



NOTE

When gas vents or absorbers are foreseen, there must be a minimum space of 185 mm between the back of the switchgear and the installation room wall.

Installation room

The installation room must be prepared to suit the size and version of the switchgear. Compliance with the distances indicated will ensure that the

equipment functions correctly and safely. Consult ABB if the installation conditions differ from those indicated.

Room layout

IAC A-FL 12.5 kA, 1sec against a wall

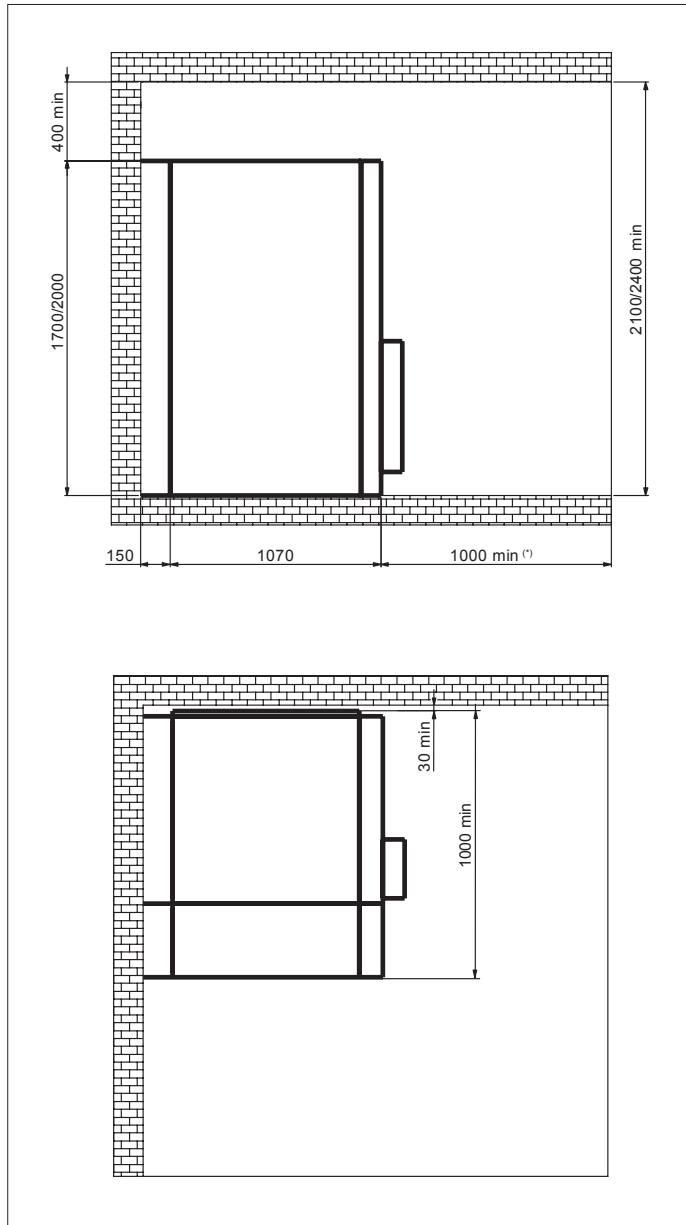

Figure 25. Distances from the walls of the installation room with compartment for the exhaust gas on the rear, solution IAC A-FL 12.5 kA, 1s against the wall

IAC A-F 16 kA

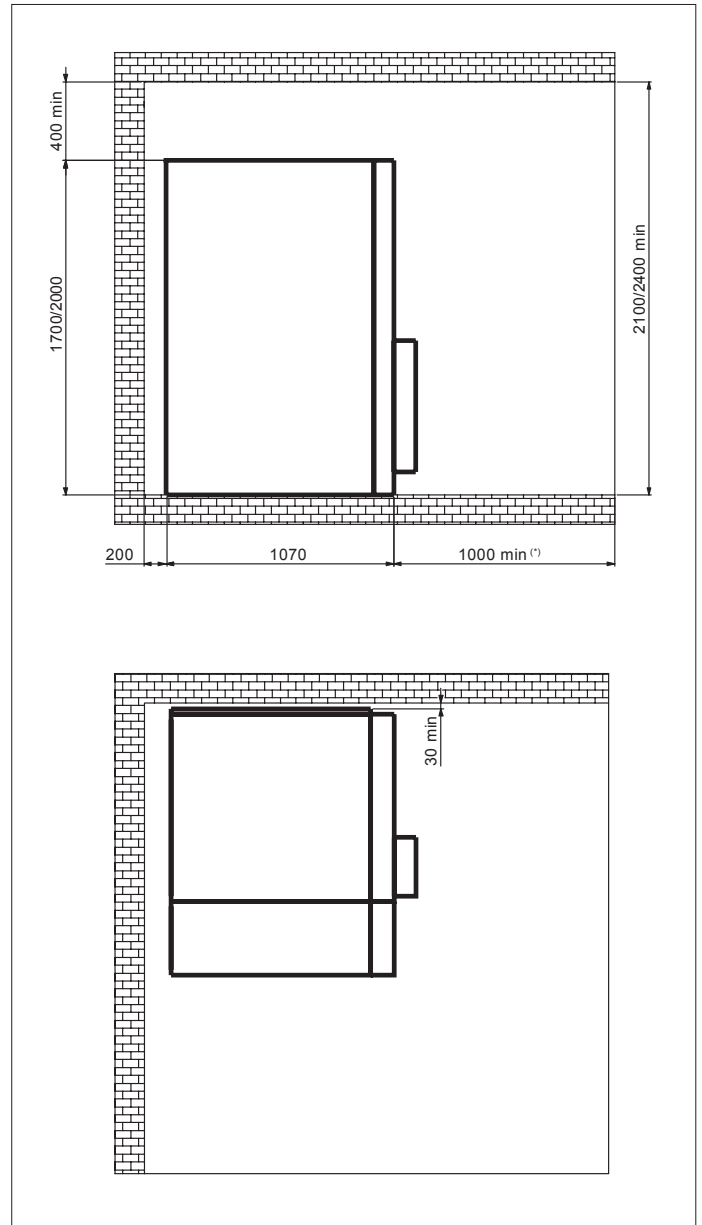

Figure 26. Distance from walls of installation room with gas exhausting compartment at rear, solution IAC A-F 16 kA 1s

^(*) 1300 mm min at least for panels with circuit-breaker



ATTENTION

IAC A-FL version – No access to Rear side of the Swb while is in service. Installation distances to be respected.



ATTENTION

IAC A-FL version – Do not access the rear or side parts of the switchgear while this is under service conditions. Compliance with the installation distances is mandatory.

Room layout

IAC A-FL 12.5 kA filters

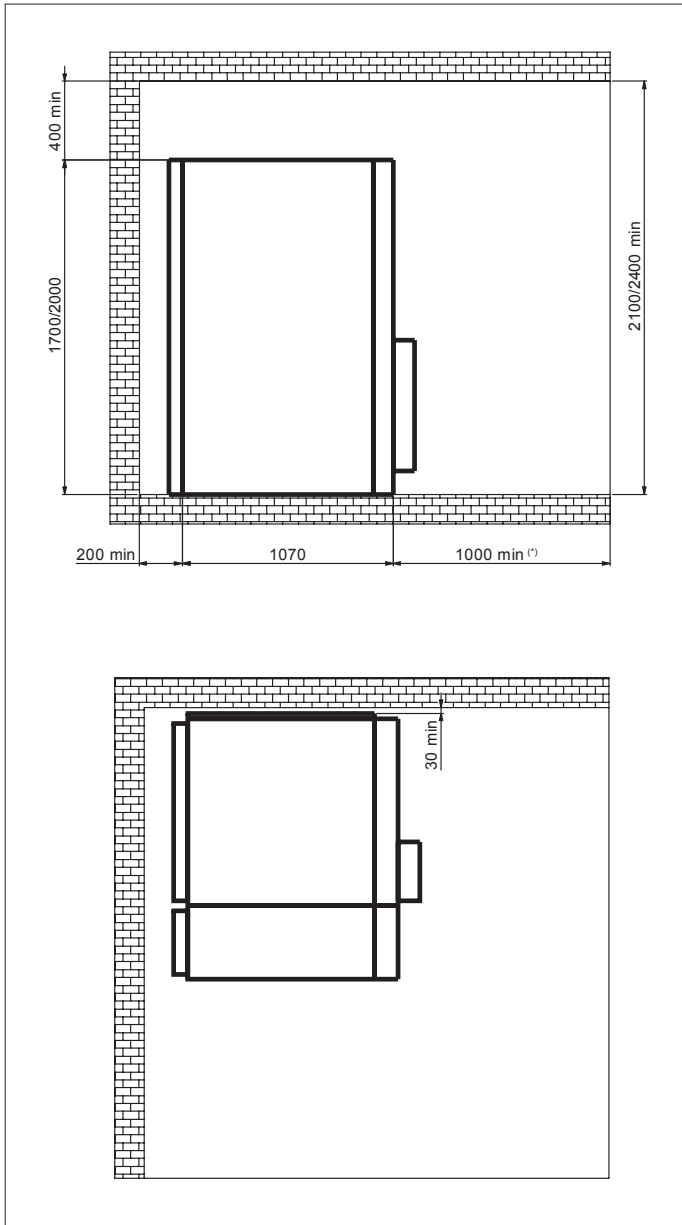

Figure 27. Minimum distances from the walls of the installation room, solution IAC A-FL 12.5 kA 1s with filters installed on each individual unit

IAC A-FLR 16 kA against a wall

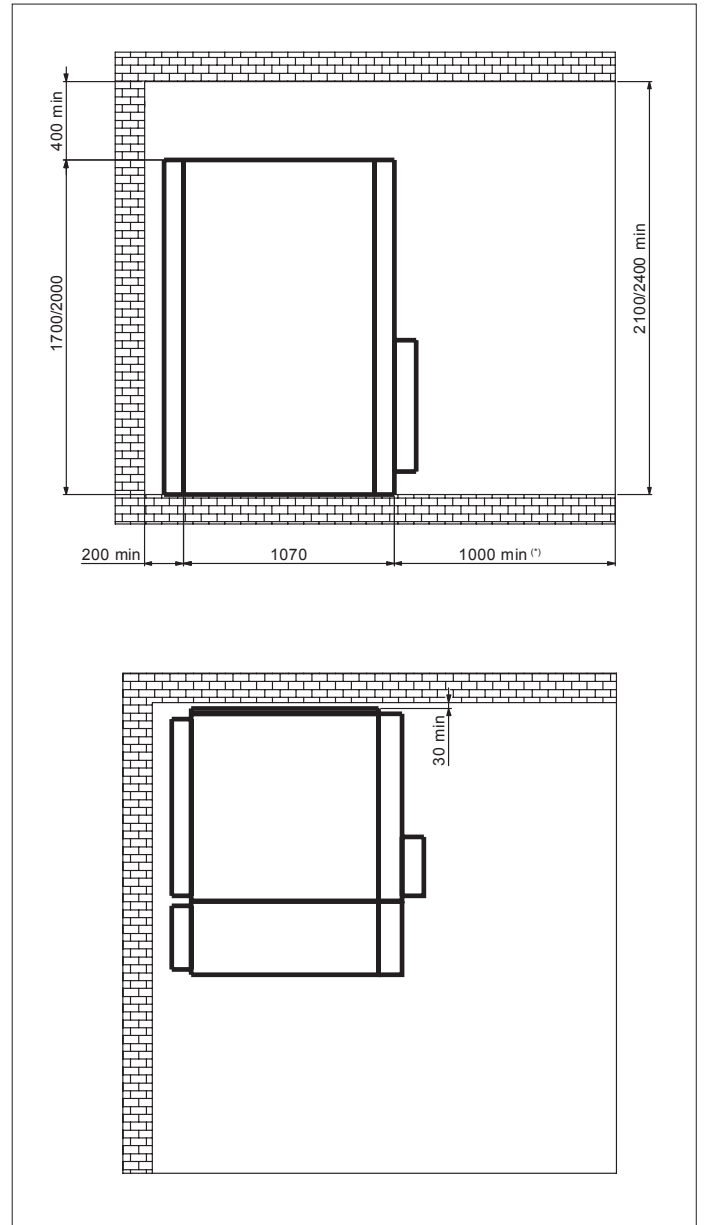

Figure 28. Minimum distances from the walls of the installation room, solution IAC A-FLR 16 kA 1s with filters installed on each unit

* 1300 mm at least for panels with circuit-breaker



ATTENTION

IAC A-FL version – Do not access the rear part of the switchgear while this is under service conditions. Compliance with the installation distances is mandatory.



ATTENTION

IAC A-FLR version – No access limitations to the Swg Room. Installation distances to be respected.

Room layout

IAC A-FLR 21 kA filters

IAC A-FLR 21 and 25 kA⁽²⁾ gas exhaust duct

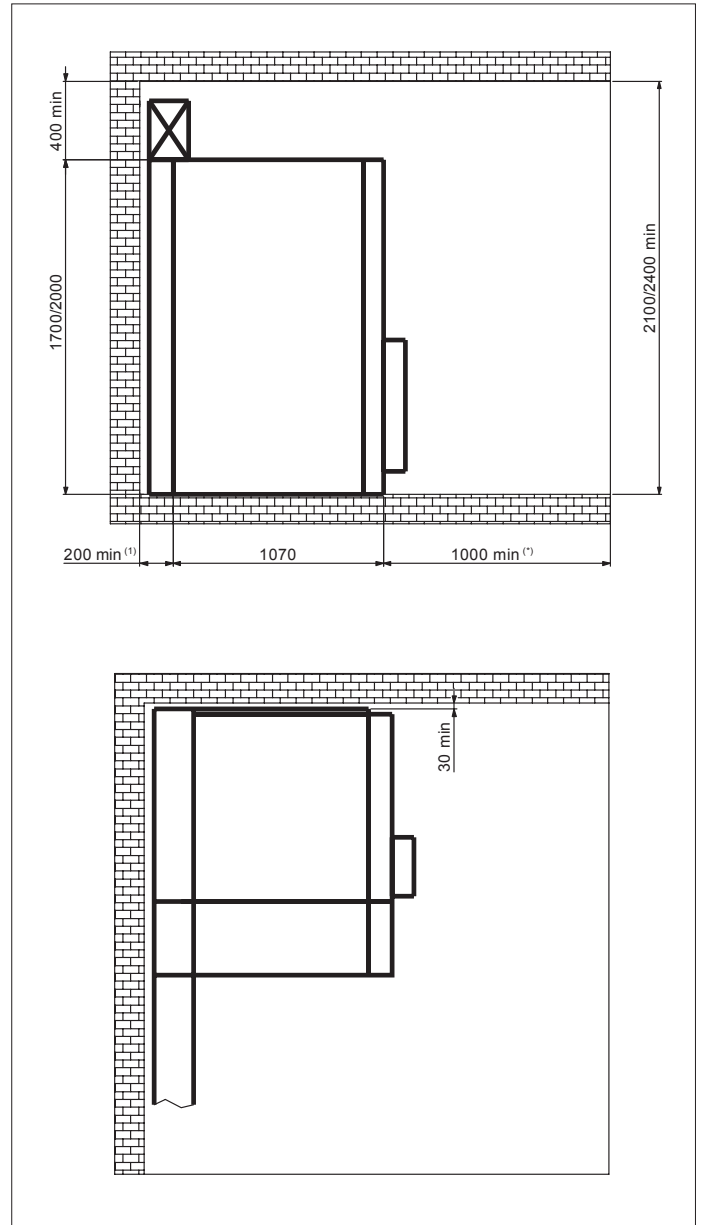
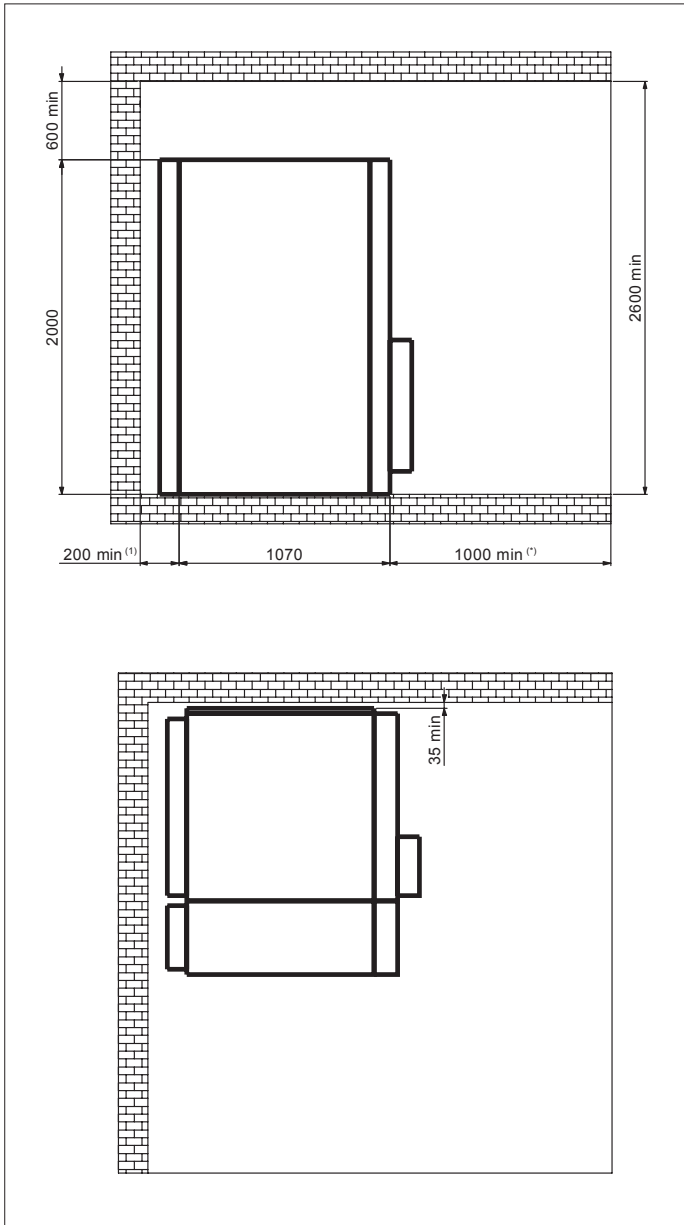

Figure 29. Minimum distances from the walls of the installation room, solution IAC A-FLR 21 kA 1s with filters installed on each unit

Figure 30. Minimum distances from the walls of the installation room, solution IAC A-FLR 21/25⁽²⁾ kA 1s with gas exhaust ducts

⁽¹⁾ 1300 mm at least, for panels with circuit-breaker

⁽¹⁾ For special conditions defined by ABB, the minimum distance can be up to 130 mm

⁽²⁾ Only for 12 kV LSC2A units, height 2000 mm and width 750 mm (except for units SBC-W, SBS-W, SDD, UMP and SBR)



ATTENTION

IAC A-FLR version – No access limitations to the Swg Room. Installation distances to be respected.

Room layout

IAC A-FLR 21 kA downward gas exhaust

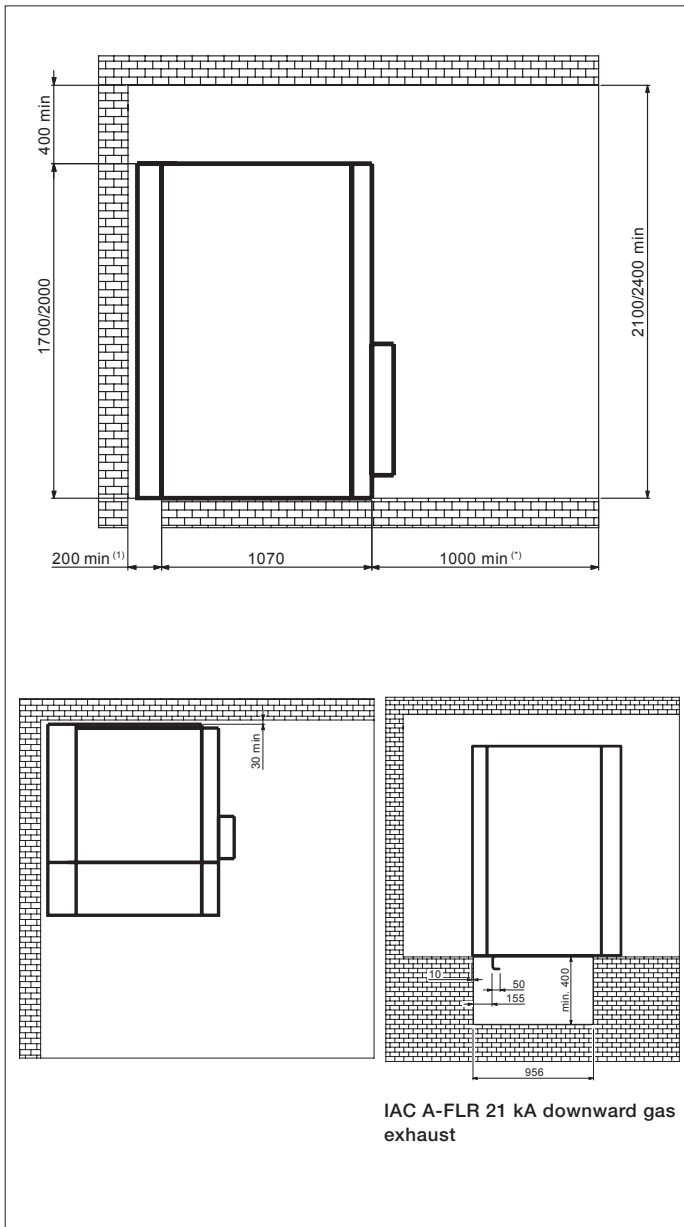

Room layout for unit with withdrawable circuit-breaker (LSC2B)

IAC A-FLR 25 kA filters

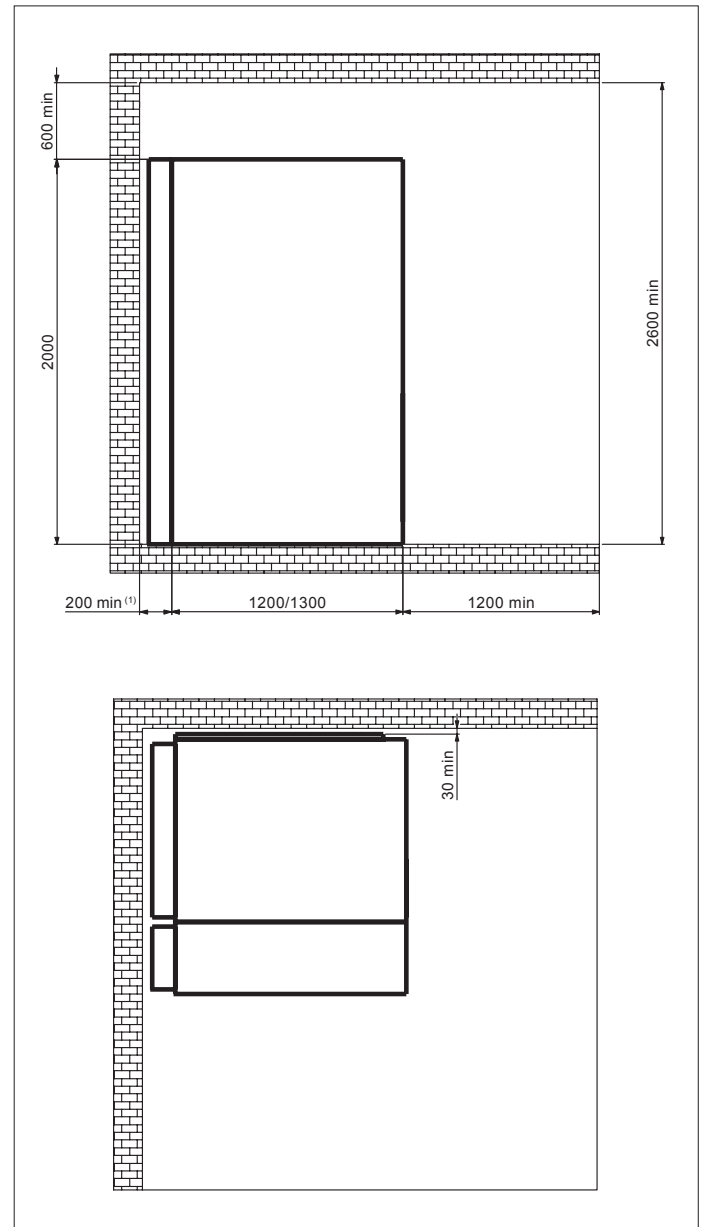

Figure 31. Minimum distances from walls of installation room, solution IAC A-FLR 21/25⁽²⁾ kA 1s with gas exhausted downwards

Figure 32. Minimum distances from the walls of the installation room, solution IAC A-FLR 25 kA, 1s @ 12-17.5 and 16 kA, 1s @ 24 kV with filters installed on each unit

⁽¹⁾ 1300 mm at least, for panels with circuit-breaker

⁽¹⁾ For special conditions defined by ABB, the minimum distance can be up to 130 mm

⁽²⁾ Only for 12 kV LSC2A units, height 2000 mm and width 750 mm (except for units SBC-W, SBS-W, SDD, UMP and SBR)

Room layout for unit with withdrawable circuit-breaker (LSC2B)

IAC A-FLR 25 kA gas exhaust duct

IAC A-FL 12.5 kA filters

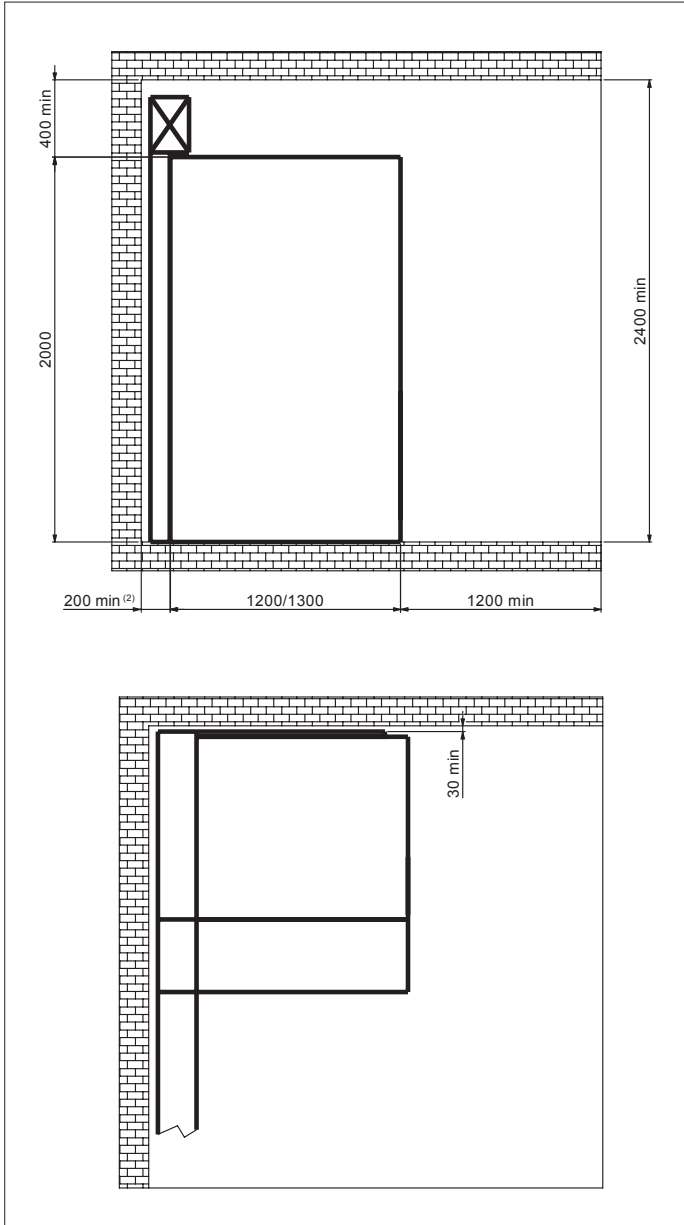

Figure 33. Minimum distances from the walls of the installation room, solution IAC A-FLR 25 kA, 1s @ 12-17.5 and 21 kA, 1s @ 24 kV with gas exhaust ducts

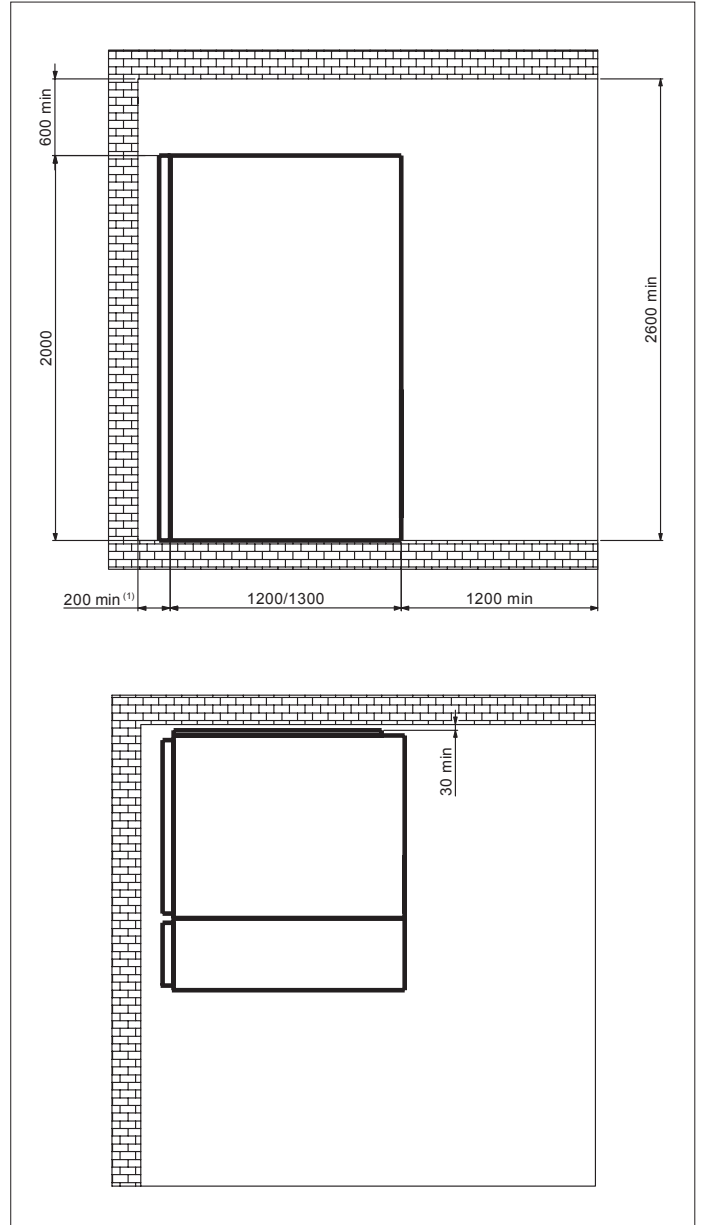

Figure 34. Minimum distances from walls of installation room, solution IAC A-FL 12.5 kA 1s with filters installed on each individual unit

⁽¹⁾ For special conditions defined by ABB, the inimum distance can be up to 130 mm

⁽²⁾ In the case of special conditions, contact ABB for the minimum distances required

4.3.2 Cable passage hole dimensions and fixing points

The following figures show the locations and sizes of the cable passage holes under the different units. These holes must be made before installation of the switchgear. The figures also

show the switchgear fixing points. There is one fixing point in each corner of the unit (4 per unit). Units without cable entry have dimensions and fixing points according to the width of the unit 10 mm anchoring bolts can be used for fixing.

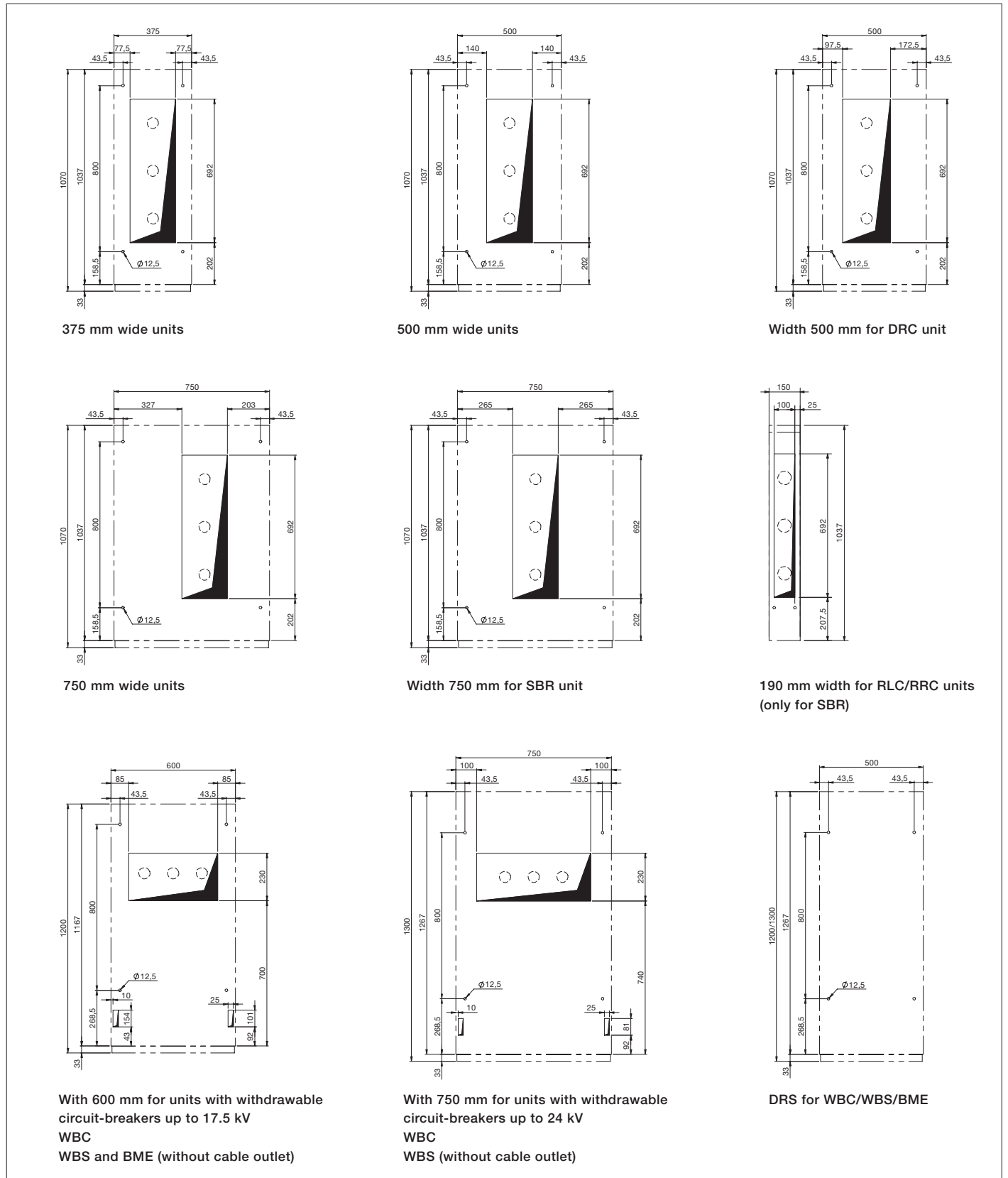

Figure 35.

4.3.3 Medium voltage cable locations and lengths

The medium voltage cable lengths (distance of the cable connection point from the floor) depend on the units and accessories used. The following figures and table show the cable lengths and locations for the different units.

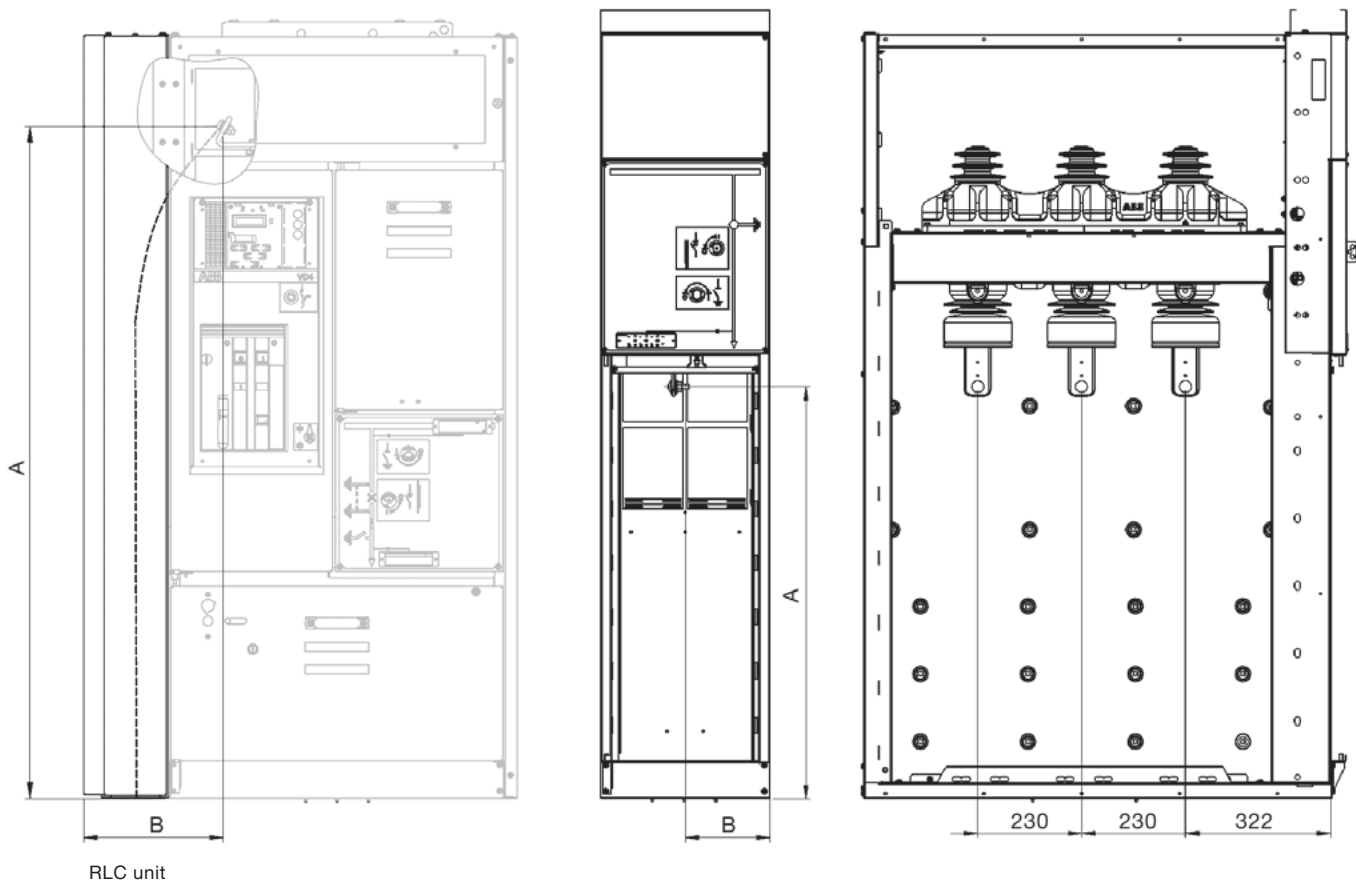

Figure 36. Medium voltage cable lengths

	Details	190 mm width		375 mm width		500 mm width		750 mm width	
		A (mm)	B (mm)	A (mm)	B (mm)	A (mm)	B (mm)	A (mm)	B (mm)
SDC	Basic	-	-	920	210	920	275	-	-
	With CT	-	-	-	-	530	275	530	265
SDM	Basic	-	-	-	-	-	-	525 ⁽¹⁾	275 ⁽¹⁾
SDD	Basic	-	-	-	-	-	-	920	210
SFC	292 mm fuse	-	-	600	200	600	240	570	400
	442 mm fuse	-	-	450	200	450	240	570	400
SBC/SBC-W	Basic	-	-	-	-	-	-	610	355
	With CT	-	-	-	-	-	-	500	340
DRC	Basic	-	-	870	180	670	240	-	-
	With CT	-	-	-	-	530	275	-	-
SBR	Basic	-	-	-	-	-	-	400	390
UMP	With CT	-	-	-	-	-	-	550	270
HBC	Basic	-	-	-	-	608	275	-	-
	With CT	-	-	-	-	460	325	-	-
	With sensor Kevcr	-	-	-	-	583/450 ⁽²⁾	275	-	-
RLC/RRC H1700	Basic	1520	265	-	-	-	-	-	-
	With SBR	1495	310	-	-	-	-	-	-
	With HBC	1435	280	-	-	-	-	-	-
RLC/RRC H2000	Basic	1645	305	-	-	-	-	-	-

⁽¹⁾ With optional cable terminal

⁽²⁾ Central phase (L2)

Table 4. Medium voltage cable lengths and locations

LSC2B units

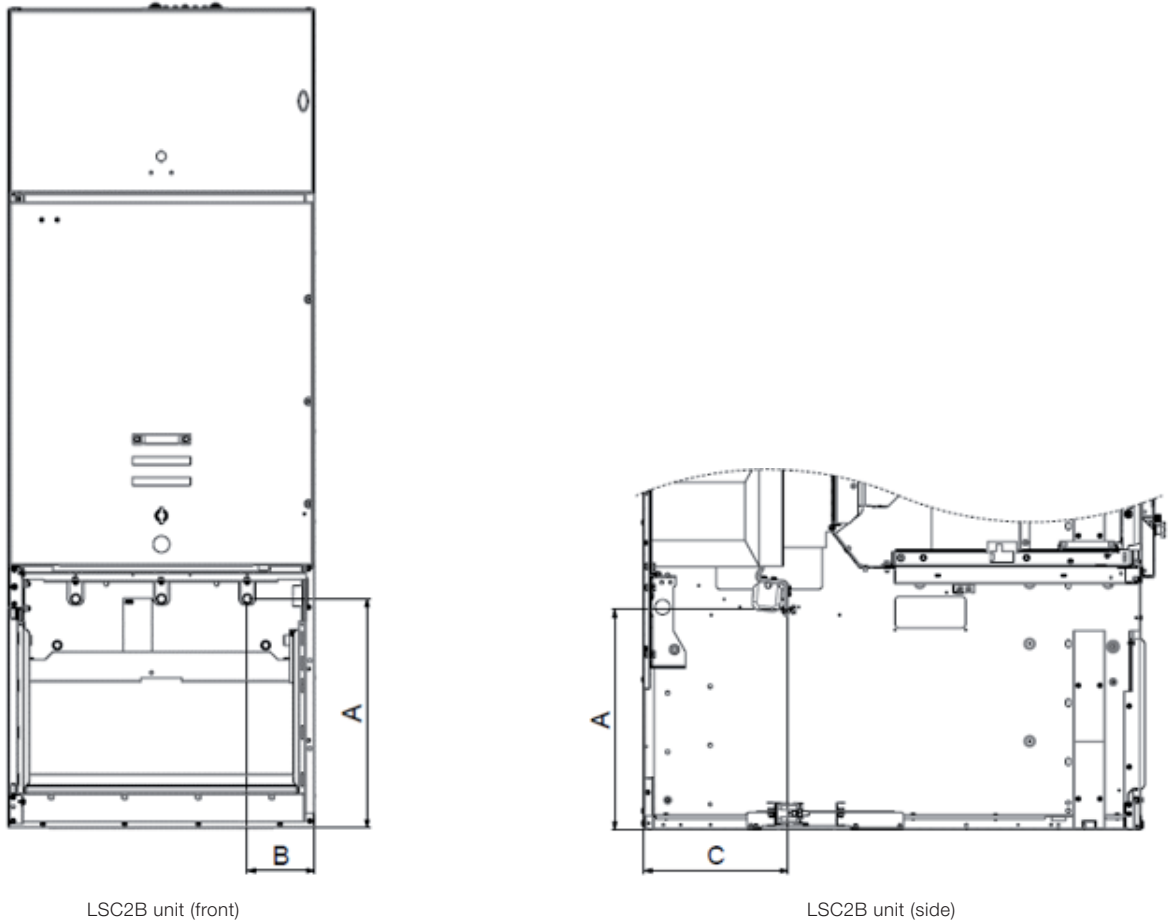

Figure 37.

Medium voltage cable positions and lengths

	Details	Width 600 mm			Width 750 mm		
		A (mm)	B (mm)	C (mm)	A (mm)	B (mm)	C (mm)
WBC/BME	Baseplate or with CT	600	150 ⁽¹⁾	332	600	165 ⁽¹⁾	367

⁽¹⁾ Distance between side wall of panel and first connection cable

4.4 Foundations

4.4.1 Foundation types

General aspects

The switchgear must be erected on a foundation that fulfils the requirement of a 2 mm maximum horizontal height deviation in relation to the length and diagonal of the switchgear. These calculations must be made by technically qualified personnel.

4.5 Installation procedure for units

4.5.1 Assembly of the first two switchgear units



WARNING

Before positioning the different switchgear units, check the floor levelling, with particular attention to the longitudinal flatness (maximum levelness 2/1000).



NOTE

If horizontal gas vent ducts are provided, mount the joint brackets unit by unit right from the start (see 4.6.2).

4.5.2.1 Removing roof plates

Plate dismantling is carried out as follows:

- Unscrew the screws present at both ends of the roof.
- Remove the plate.

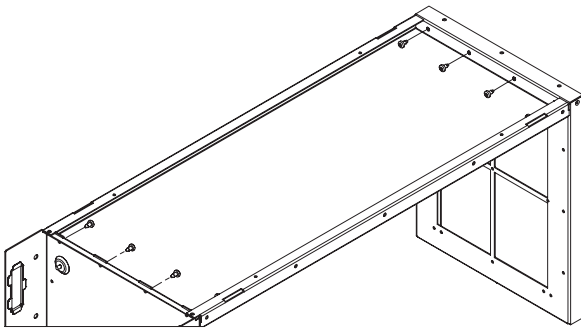

Figure 38. 375 mm wide units

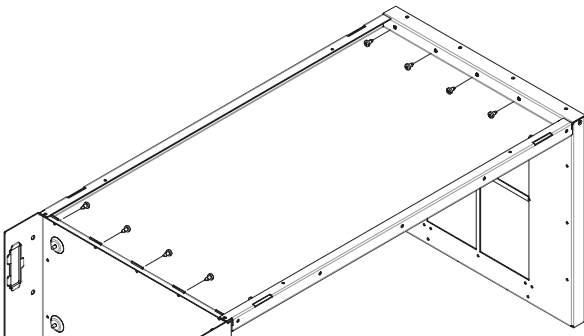

Figure 39. 500 mm wide units

4.5.2.2 Top plate removal from BIG compartments

The plate is removed in the following way:

- Unscrew the screw from the support.

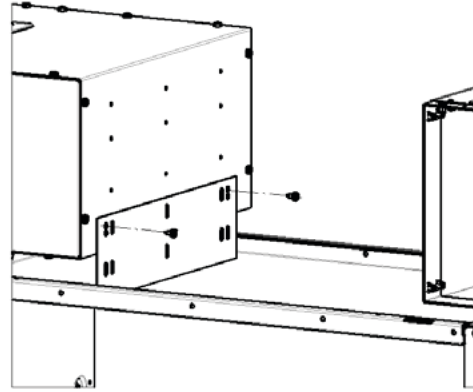

Figure 40.

- Unscrew the screws from both ends of the top.

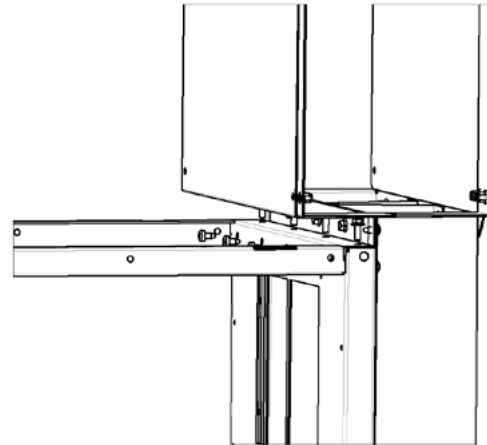

Figure 41.

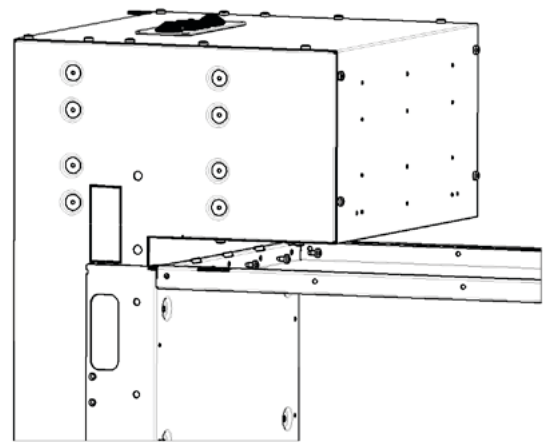

Figure 42.

c) Lift and remove the plate.

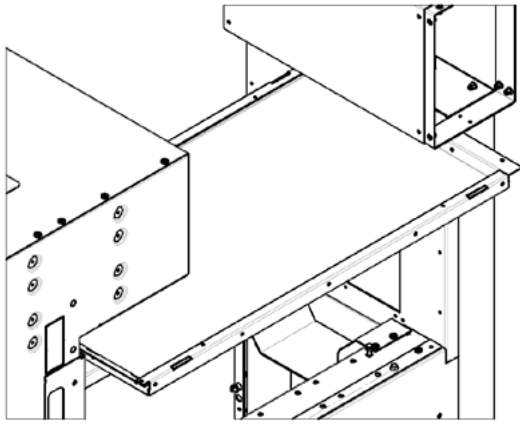

Figure 43.

4.5.3 Connecting the units

Note: do not remove the roof frame in the case of units with roof applications and SBR units.

Installation foresees the following operations:

a) Align two units side by side. Before pushing the two units completely together, make sure that the lower joining plate of the right-hand unit is in the upper position.

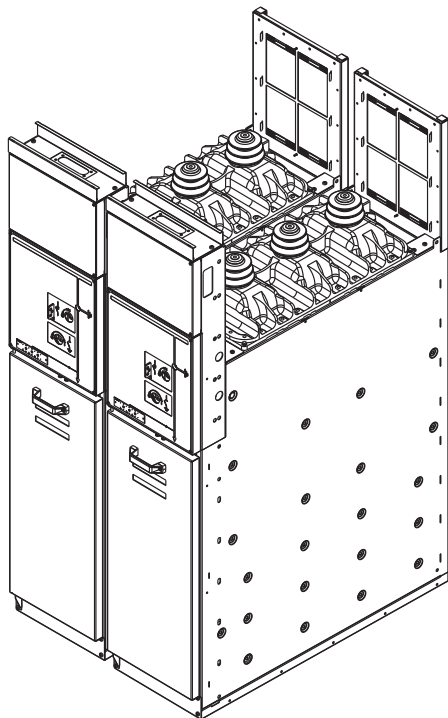

Figure 44. Two units side by side

b) Screw the joining plate and the unit plates together (with 6 Torx M6x12 screws) so that they are fully tightened. Insert a bolt (M8x20 round-headed with square neck) with a nut (M8 hexagonal nut with flange) (figure 45) to tighten the units and the joining plate.

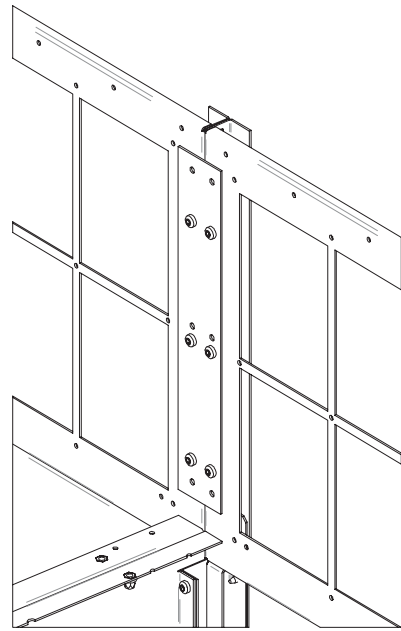

Figure 45. Screws for the top joining plate

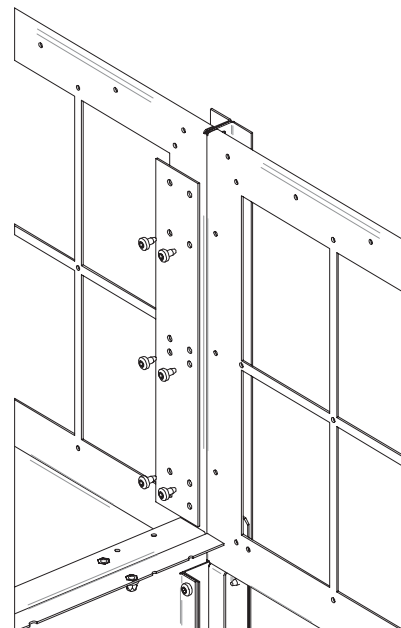

Figure 46. Plates installed

c) Insert 5 bolts (M10x20 hexagonal with flange) and 5 nuts (M10x20 hexagonal with flange) into the LV and instrument compartment (front, upper part of the units), but do not tighten them yet.

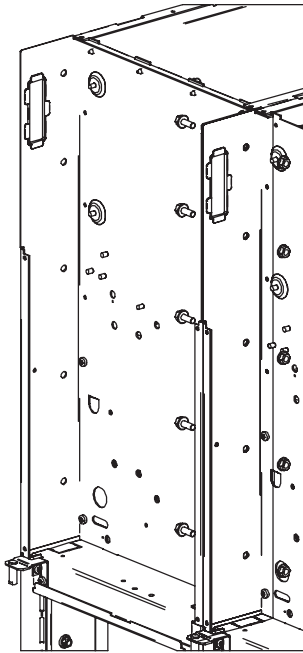

Figure 47. Places for screws

d) Insert 8 bolts (M10x20 hexagonal with flange) and 8 nuts (M10x20 hexagonal with flange) into the cable compartment (front, lower part of the units), but do not tighten them yet.

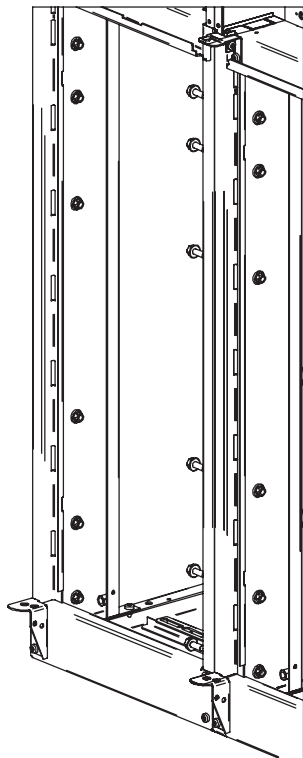

Figure 48. Screw positions

e) Use a screwdriver to trim the unit alignment. Tighten all the bolts from the front.



NOTE

Do not remove ceiling frame in the case of functional units with roof applications and SBR units.

f) For WBC and WBS units, insert 6 hexagonal bolts with the relative nuts.

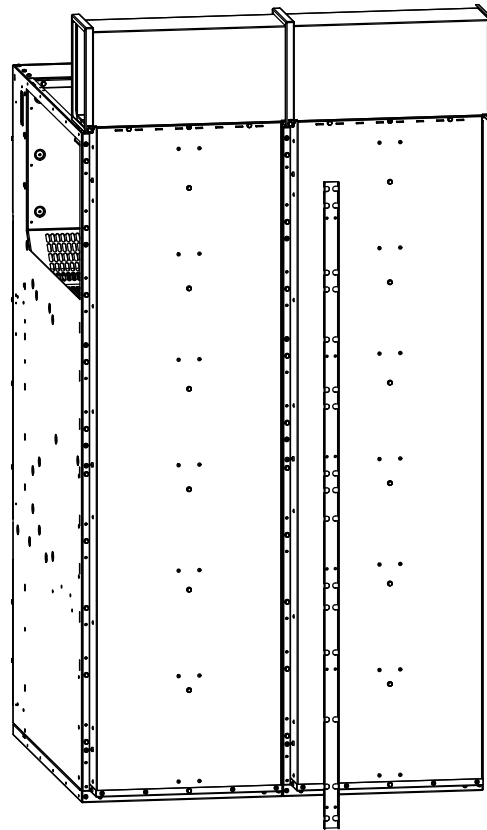

Figure 49. Screw positions for WBC – WBS units

4.5.4 Assembling the remaining switchgear units

After connecting two units, bring the third unit to the place of installation. Then repeat the following operations:

- a) Removing the roof plates
- b) Connecting the units
- c) Repeat the same operations for the remaining units.

4.5.5 Switchgear fastening to the floor

Floor preparation

The panels must be positioned on a standard reinforced concrete floor. If necessary, the floor must be prepared with raceways for routing the power cables. The preparation tasks are the same for all types of panels (400-630 A).

To reduce the depth of the raceways for 400-630 A panels to 350 mm (or even do away with them in certain cases), the cubicles can be installed on a raised base made of reinforced concrete, which must be prepared at the same time as the construction works of the building in question.

Raised panel position

- 1) The raised position can be used when cable raceways cannot be created.
- 2) This does not obstruct the activities of the substation.

Surface flatness of the base

- 1) Pass a 2-meter level over the surface of the base in all directions to check for flatness and evenness. The maximum deflection is 5 mm.
- 2) To prevent the base from being damaged by equipment on wheels (e.g.: circuit-breakers), the surface must possess 33 MPa strength or more.

How to fasten the cubicles

The cubicles must be fastened together with the supplied bolts and screws.

4.5.6 Connecting the main busbars

General warnings and precautions



DANGER

A warning sign is placed on the top plate to indicate the presence of high voltage under the roof.



CAUTION

It is recommended to mount the busbars starting from the top of the units.



NOTE

Tighten to the correct torque. The torques are indicated in the "Tightening torques for steel screws and nuts/bolts" table.



NOTE

It is important for the screws to be of the correct length.

The busbar connections are made through the top openings

- a) Clean and scrape the busbar connections.
- b) Clean the insulation of the busbar sections with a soft, dry cloth and check for any insulation damage.
- c) Install the busbars unit by unit. Insert the screws, busbars and other required components in the correct positions and tighten them to the correct torques according to the instructions given below.

Instructions for different types of main busbar connections

The main busbars overlap each other at their contact points. This means that every other busbar is mounted on top of the other, as shown in Figure 50. Busbar spacers are used in the end units to keep the busbars in a completely horizontal position.

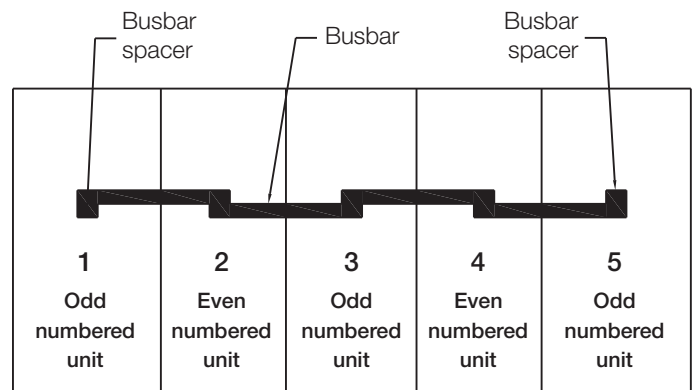

Figure 50. Main busbar connections



NOTE

Metallic terminal-covers are installed in the terminal units for 24 kV.



NOTE

Make sure the busbar spacers are positioned as shown in the figures below.

The following figures show the busbar connections for units with switch-disconnector. The components required are indicated in Table 5. The main busbar connections of each unit type with different rated currents and voltages are shown. Each figure gives a reference to the corresponding numbers of the components in Table 5.

All unit types

Part	Name
1.	Spring washer
2.	M10x40 hex socket screw
3.	Busbar spacer
4.	Field diffuser
5.	M10x60 hex socket screw
6.	Washer
7.	M10 nut
8.	Washer
9.	Insulating terminal cover
10.	Silver washer D10
11.	Busbar
12.	Conical spring washers D10
13.	Hexagonal nut M10
14.	Busbar spacer D10
15.	Compensation washer D10
16.	Round-headed socket screw M10x30
17.	Round-headed socket screw M12x40
18.	Round-headed socket screw M12x60
19.	Nut M12
20.	Conical spring washer D12
21.	Round-headed socket screw M12x50
22.	Busbar spacer D12
23.	Round-headed socket screw M12x30
24.	Round-headed socket screw M10x60
25.	Round-headed socket screw M10x50
26.	Round-headed socket screw M10x70
27.	M10x35 button-headed and square-necked bolt

Table 5. List of components used

Units with 12-17.5 kV, 630-800 A switch-disconnector

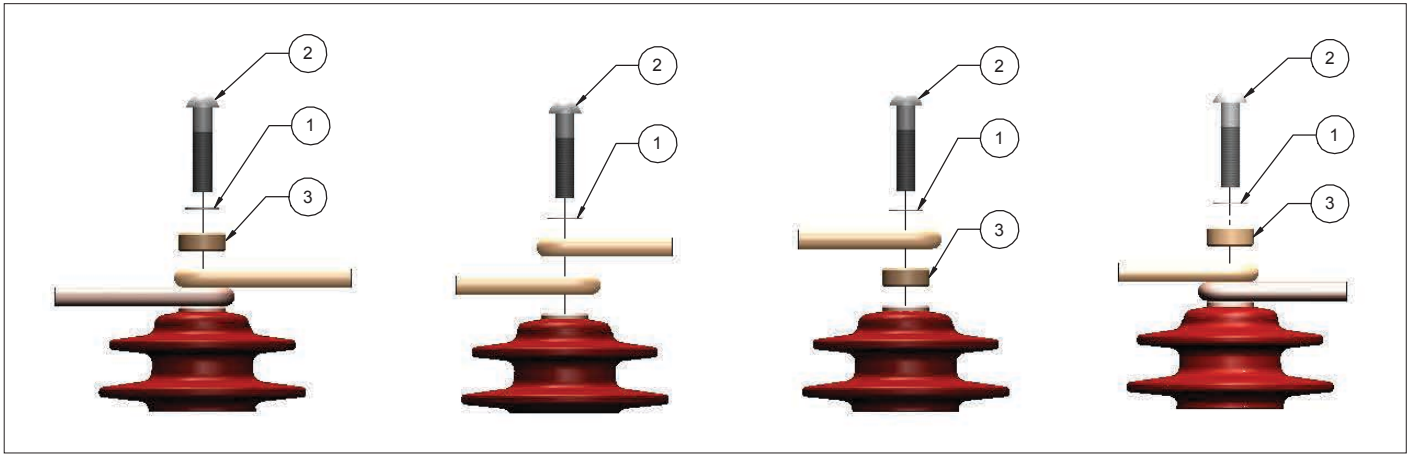

Figure 51.

Units with 24 kV, 630 A switch-disconnector

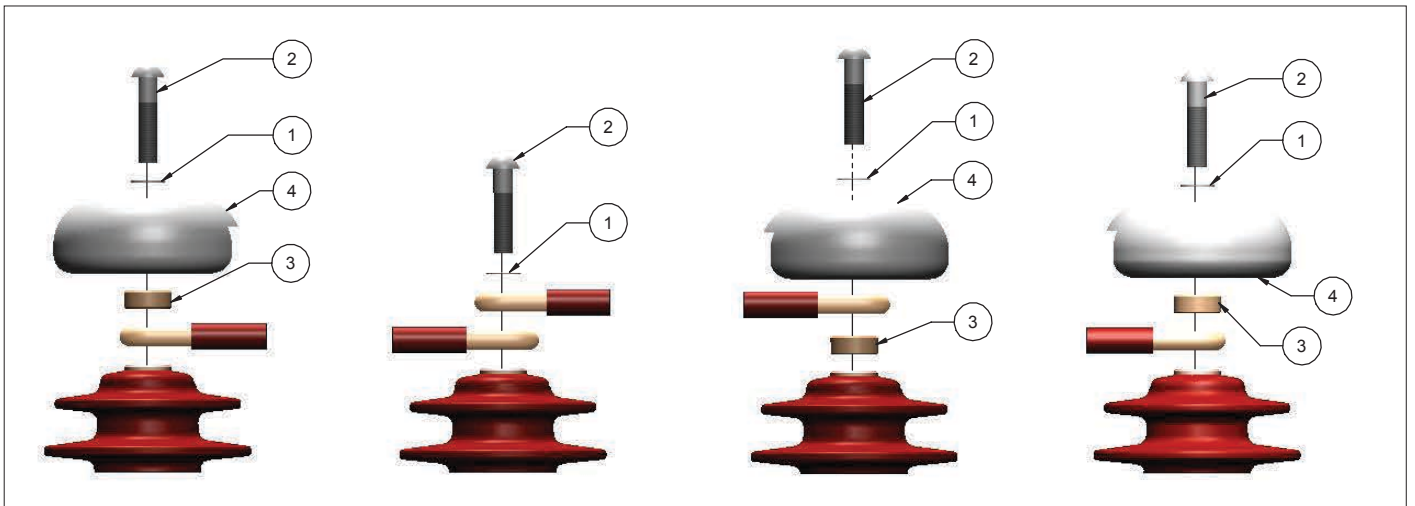

Figure 52.

Units with 12-17.5 kV, 1250 A switch-disconnector

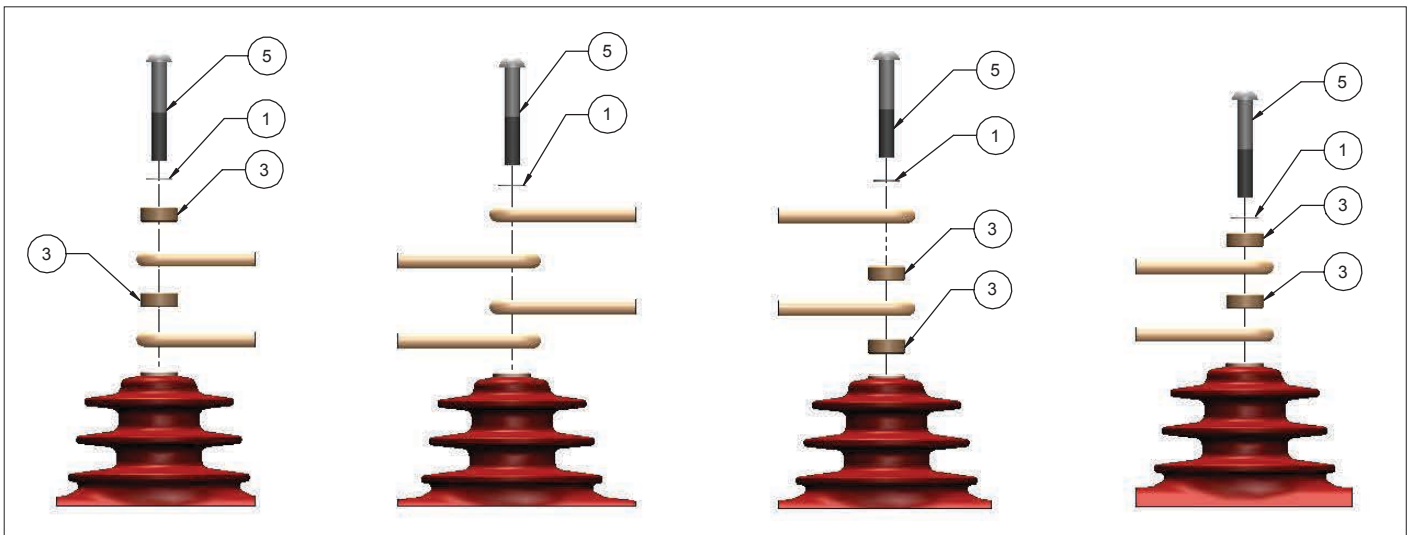

Figure 53.

DRS/DRC end or isolating units

For DRC and DRS units, the busbars are not installed directly on the top of the switch-disconnector or bushing. Therefore to

tighten the screws properly, the nuts must be installed under the busbars.

DRS/DRC 12-17.5 kV, 630-800 A end or isolating units

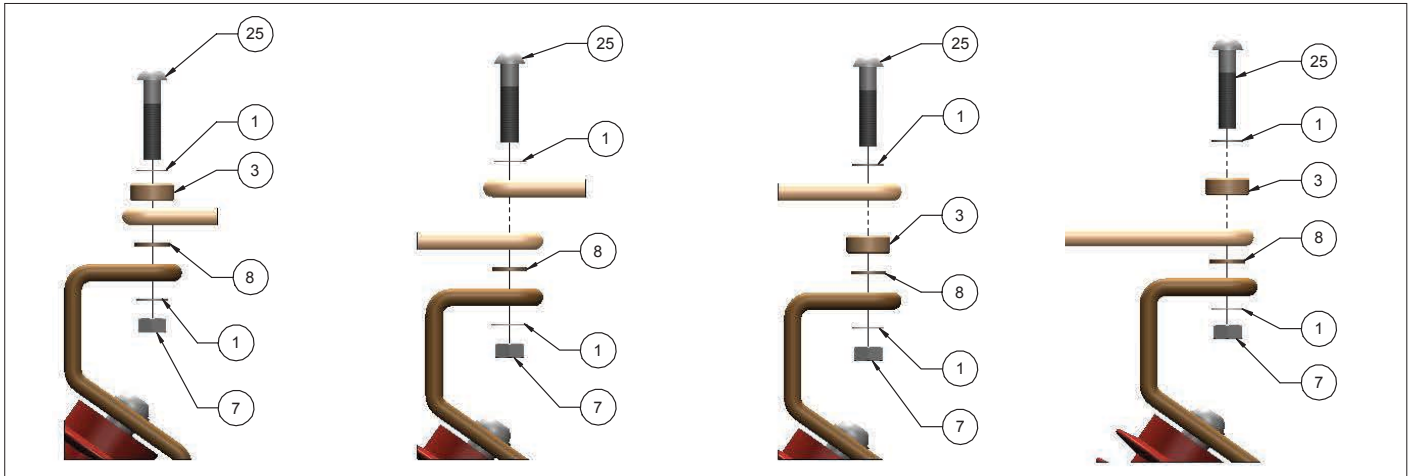

Figure 54.

DRS/DRC 24 kV, 630 A end or isolating units

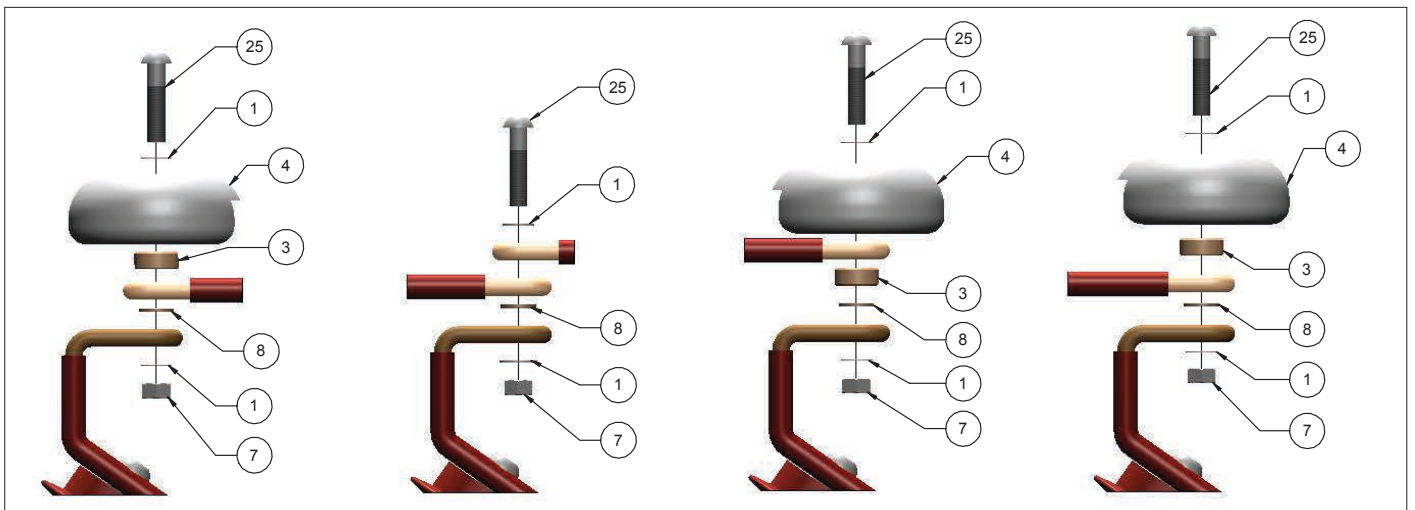

Figure 55.

DRS/DRC 12-17.5 kV, 1250 A end or isolating units

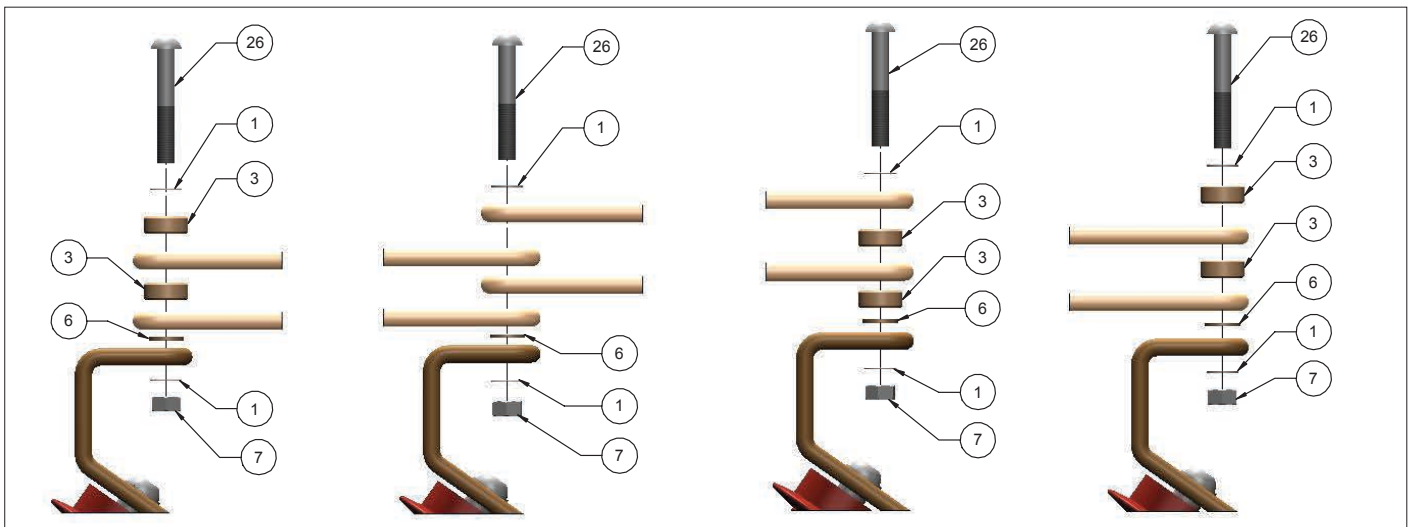

Figure 56.

For the SBR unit up to 24 kV, 630 A

Units with insulators

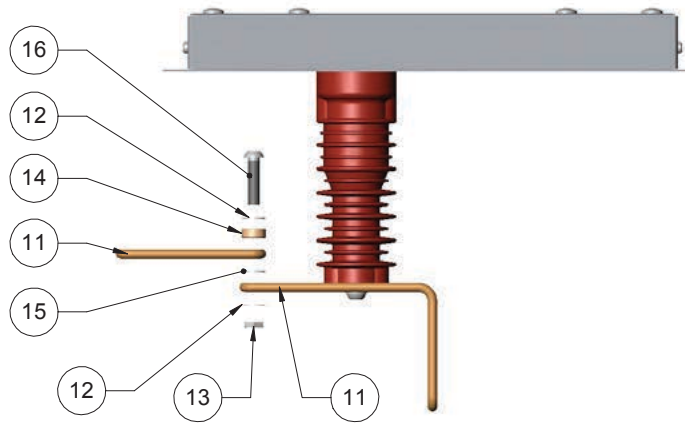

Figure 57. Busbar exit on the left

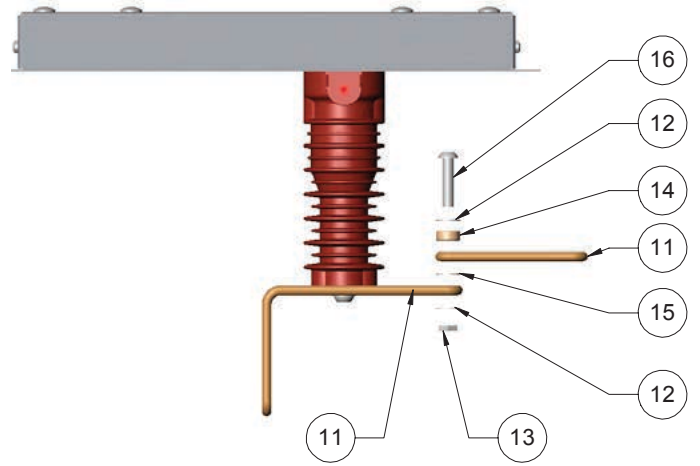

Figure 58. Busbar exit on the right

Units with current transformers and Combisensors

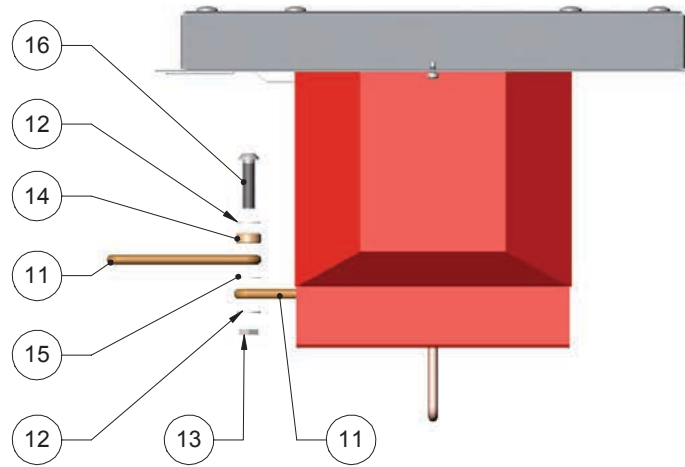

Figure 59. Busbar exit on the left

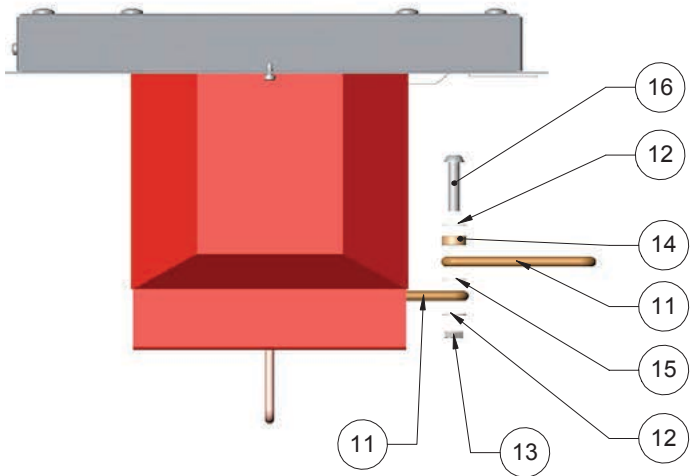

Figure 60. Busbar exit on the right

WBC - WBS, 630 A middle unit

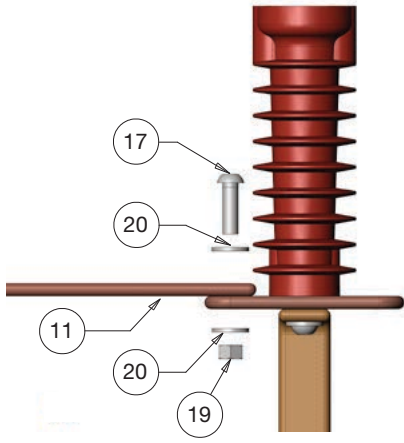

Figure 61. 630 A middle unit

WBC - WBS, 1250 A middle unit

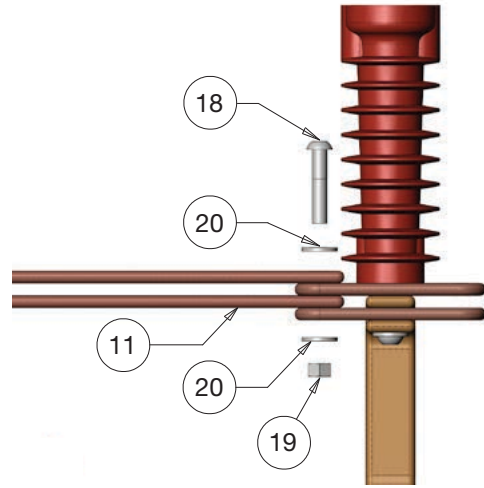

Figure 62. 1250 A middle unit

WBC - WBS, 630 A end unit

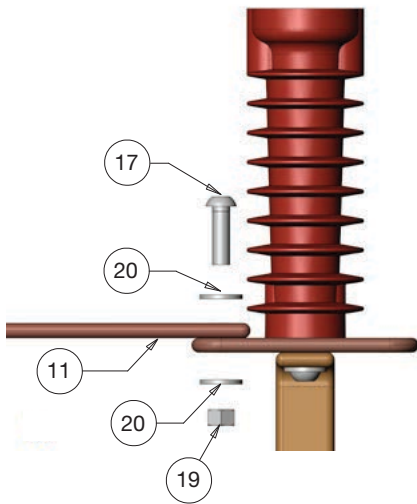

Figure 63. 630 A end unit

WBC - WBS, 1250 A end unit

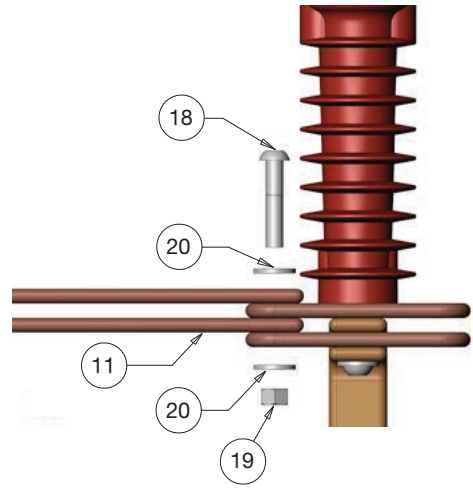

Figure 64. 1250 A end unit

Panel for coupling unit with WBC – WBS to unit with 12-17.5 kV, 630 A switch-disconnector

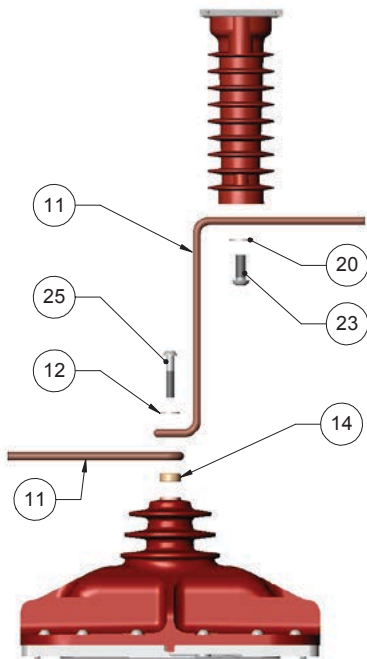

Figure 65. 12-17.5 kV, 630 A middle unit

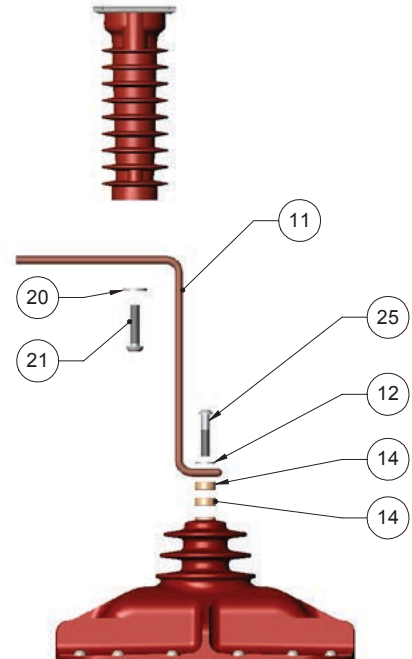

Figure 66. 12-17.5 kV, 630 A end unit

Panel for coupling unit with WBC – WBS to unit with 12-17.5 kV, 800 A switch-disconnector

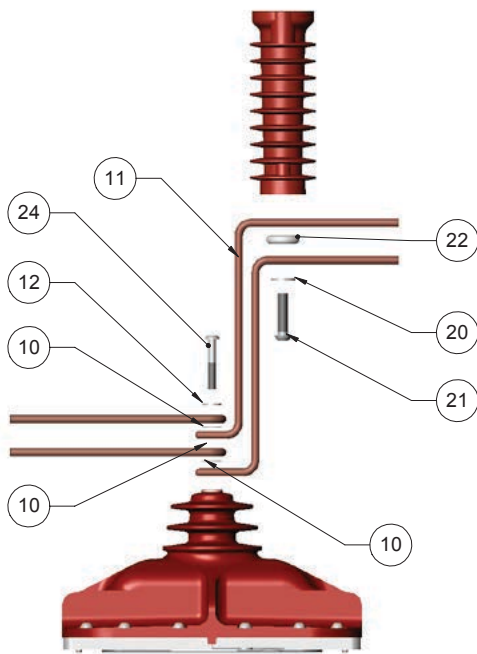

Figure 67. 12-17.5 kV, 800 A middle unit

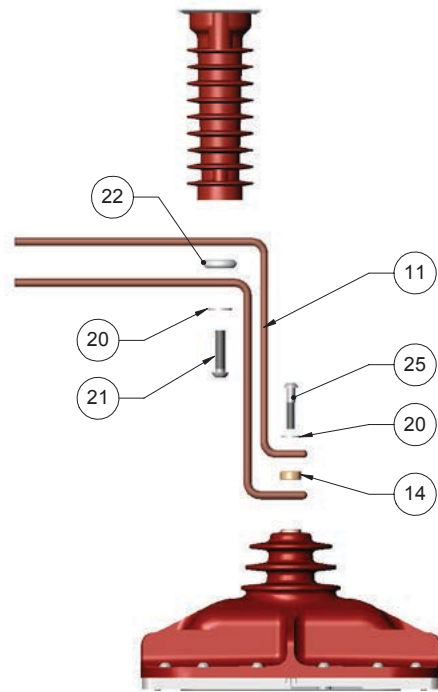

Figure 68. 12-17.5 kV, 800 A end unit

Connection between SBS and DRC units

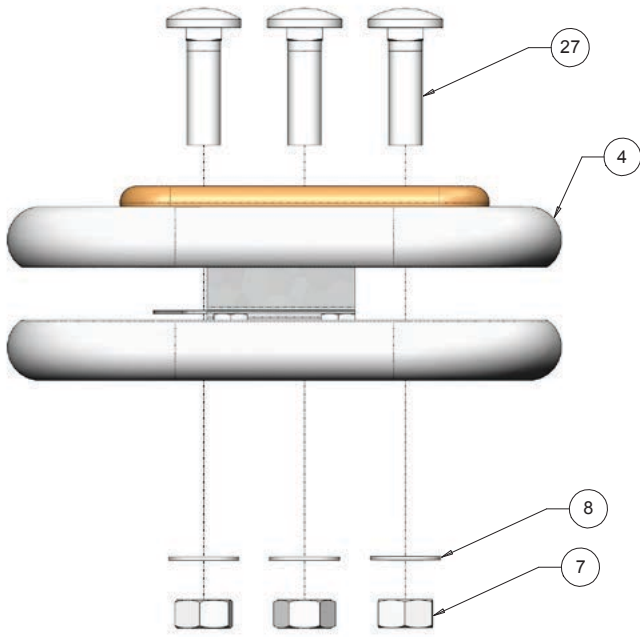

Figure 69. Busbar junction kit - 24 kV, 630 A

Connection to main busbars - SBS to DRS 12-17.5 kV - 630-800 A

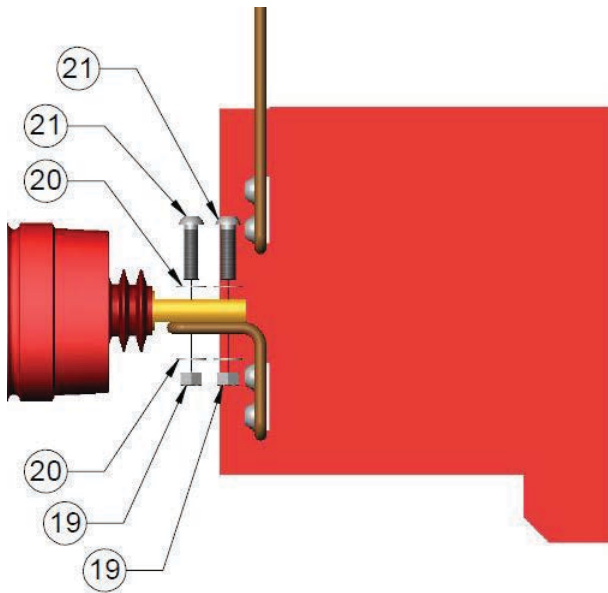

Figure 70.

4.5.7 Re-installing the roof plates

The installation operations are as follows:

- 1) Install the roof plate.
- 2) Remount the screws detached during dismantling.
- 3) For the end and isolating units:
install the double roof plate. There is no need to screw on the plates (only for IAC 21 kA 1s version).

Make sure that the double roof plate is positioned as shown in Figure 71.

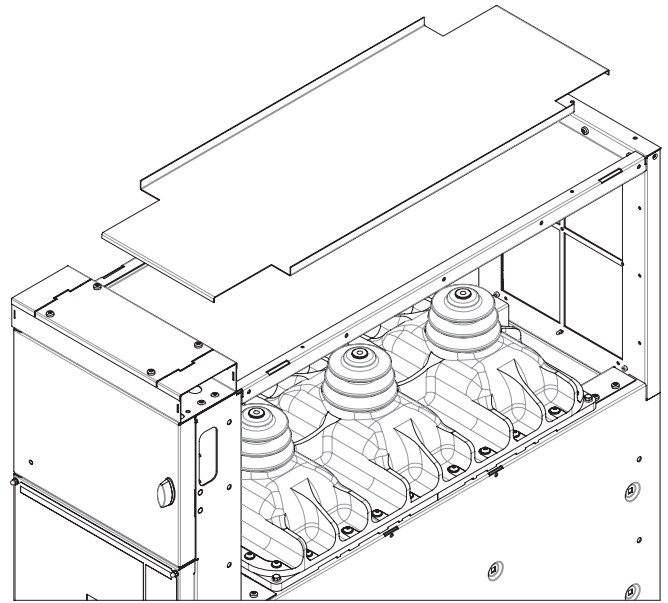

Figure 71. Installation of double roof plate

Make sure that the bent edges of the double roof plate are completely under the plate.

- 4) Install the roof joining plate with six screws (Torx screws M6x12).

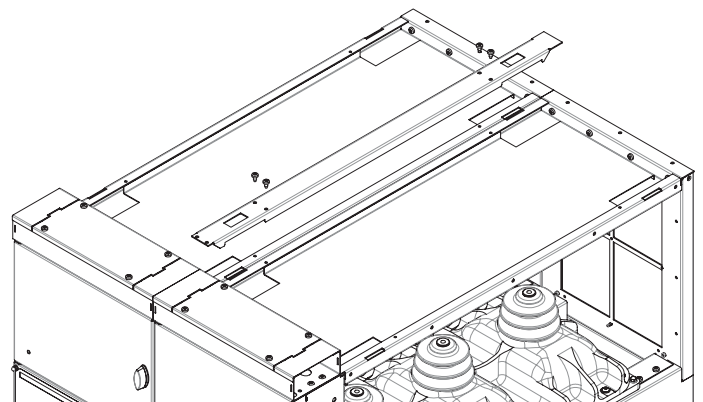

Figure 72. Outline of roof joining

4.6 Gas vent ducts

4.6.1 Installation of the gas vent ducts

The gas vent ducts are usually already installed.

a) Install the vertical part of the gas vent duct.

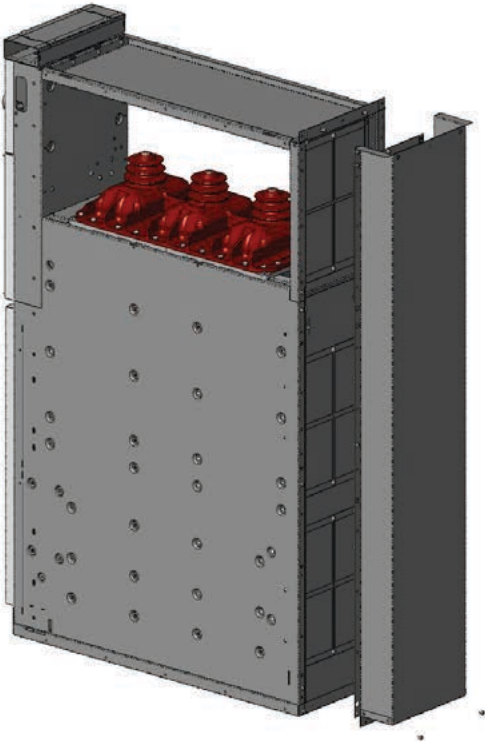

Figure 73. Installation of the vertical gas vent duct

b) Insert screws in the vertical duct (6 Torx M6x20 screws) and in the bottom plate (5 Torx M6x12 screws), and tighten them as shown in Figure 74.

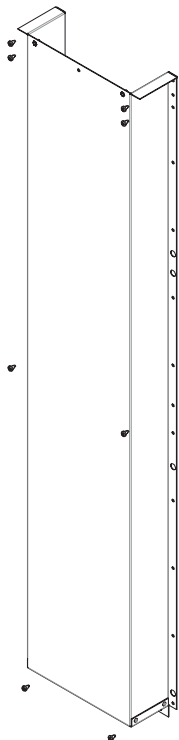

Figure 74. Screws for the vertical duct and bottom plate

c) Screw 3 additional screws (Torx M6x12) in the bottom plate as shown in Figure 75.

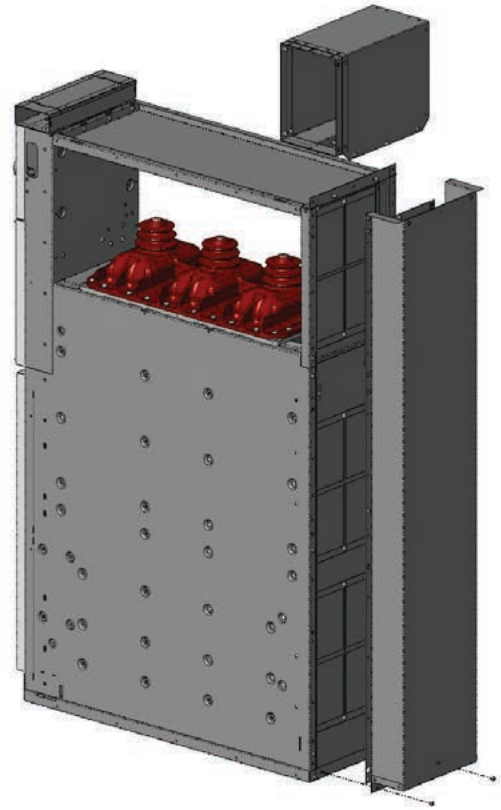

Figure 75. Additional screws for the bottom plate

d) Mount the horizontal duct onto the vertical duct. Insert the screws and nuts in it as shown in Figure 77 (4 Torx M6x12 screws, support bar and 2 M6 hexagonal nuts).

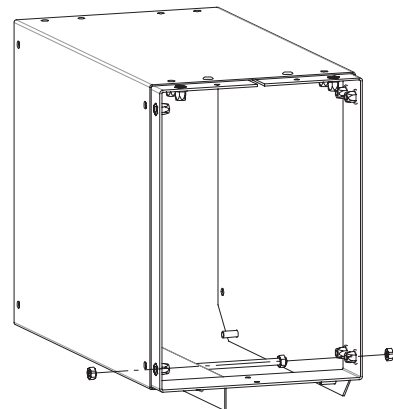

Figure 76. Screws and nuts for the horizontal duct

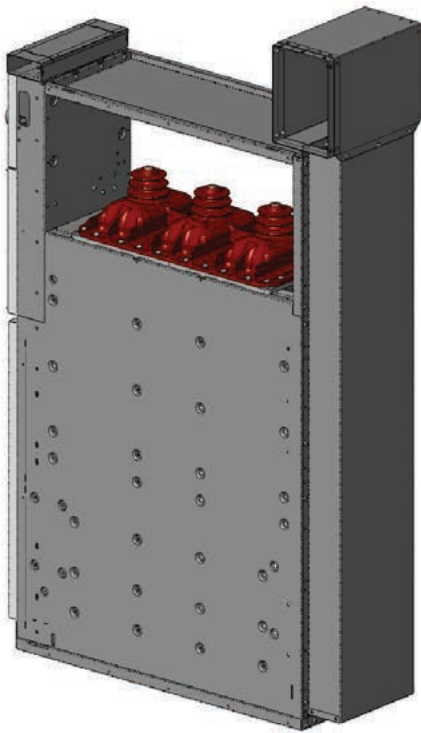

Figure 77. Installed gas vent duct

4.6.2 Connecting the gas vent ducts

- a) Install the lower locking bracket
- b) Install the upper locking bracket bar and screw up the screws (2 hexagonal bolts with flange M6x10)

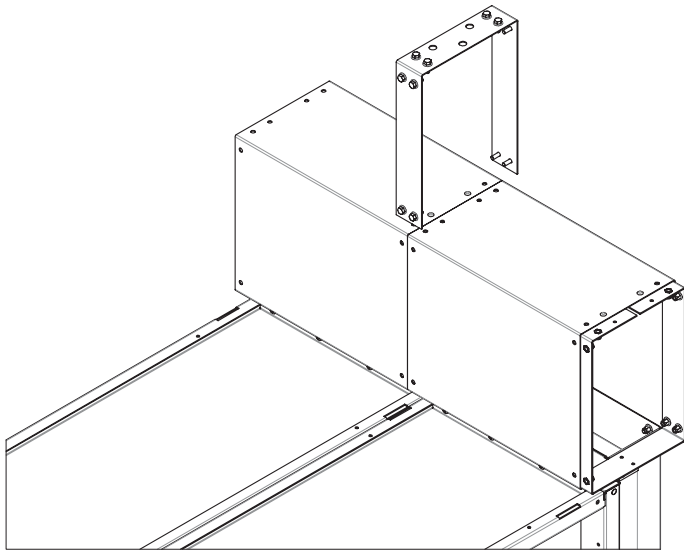

Figure 78. Upper locking bracket

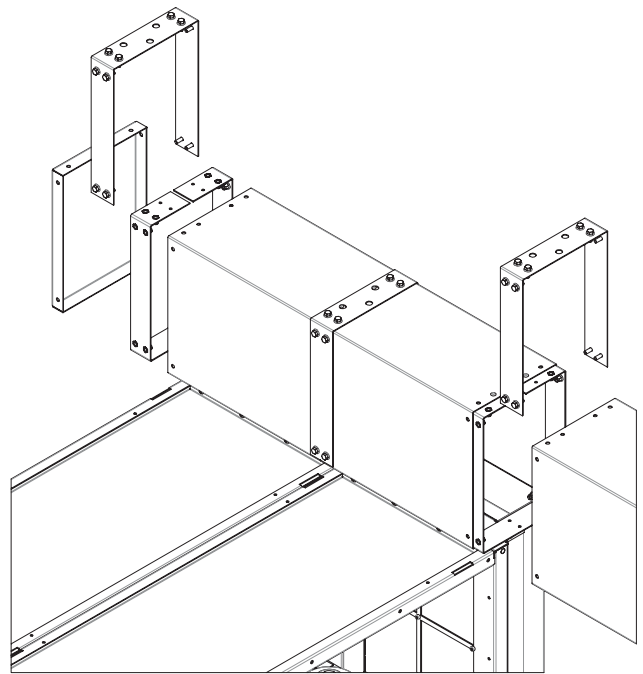

Figure 79. Connected gas vent duct; additional duct and end plate

Figure 79 shows an additional duct and end plate. Connecting these parts can be done in the same way as in the previous stages. An additional duct is used in the end unit to direct any gas due to arc faults out of the switchgear room.

The switchboard is always provided with an additional duct 1 metre long. On request an additional duct with a maximum length of 2 metres can be supplied.

In the case of 750 mm units:

- a) Install the large bottom plate
- b) Install the plate in the centre of the gas vent ducts.

Example of lateral gas outlet

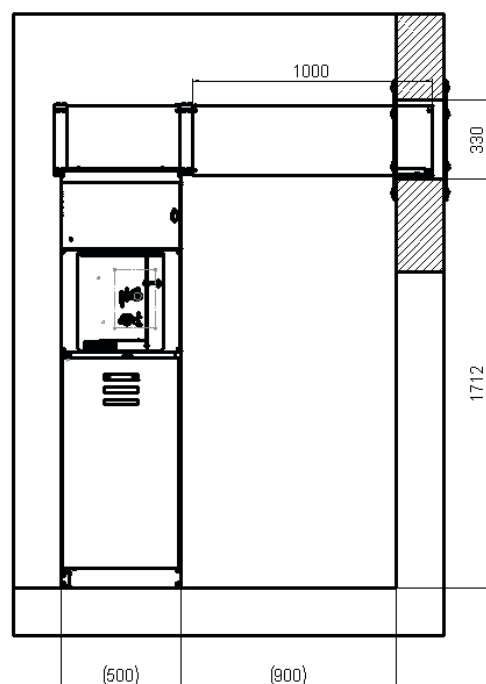

Figure 80. View from front

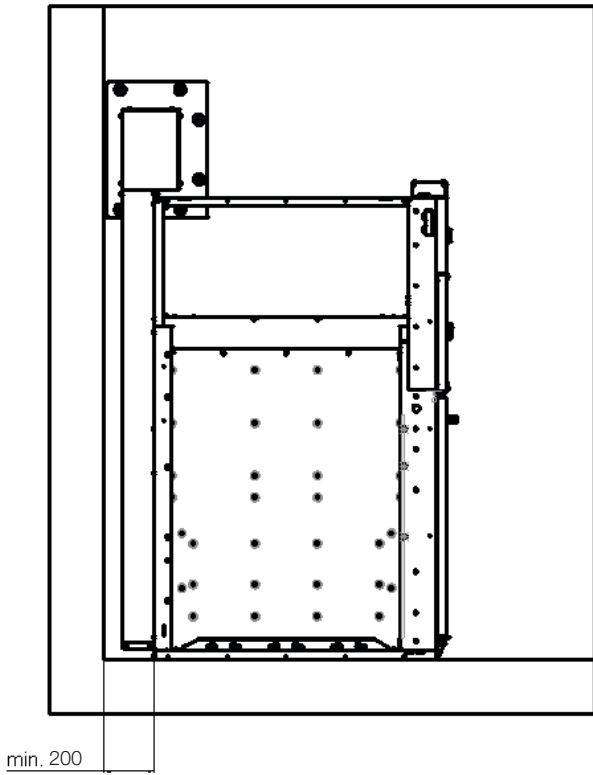

Figure 81. Side view

Example of raised lateral gas outlet

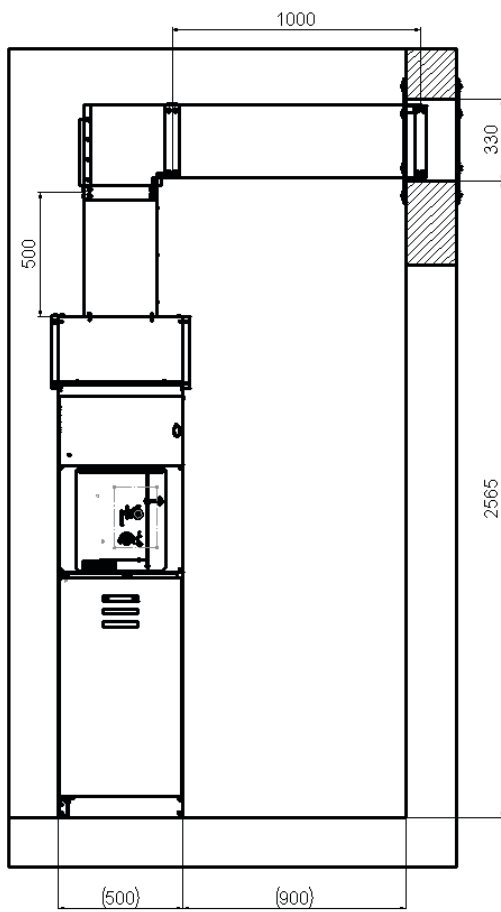

Figure 82. View from front

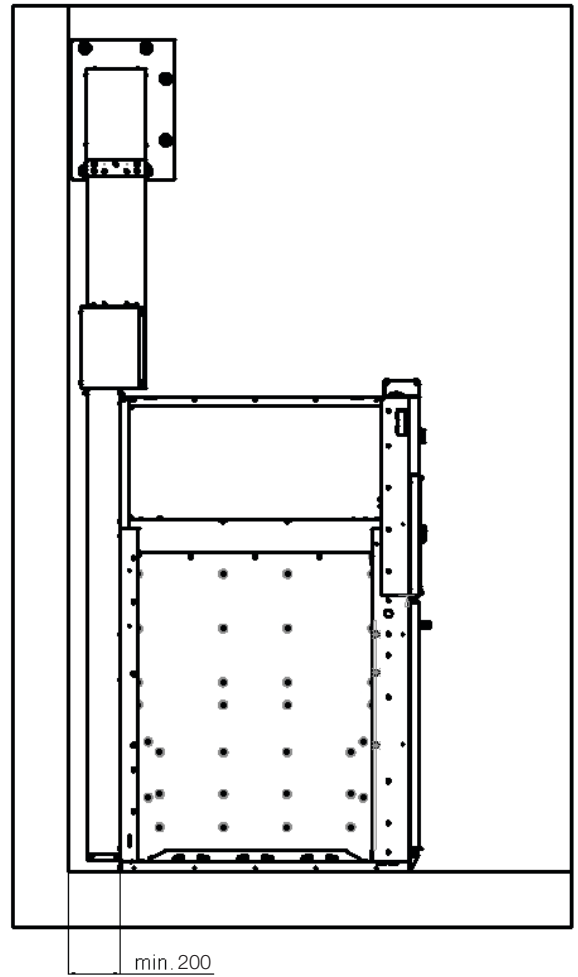

Figure 83. Side view

Example of rear outlet

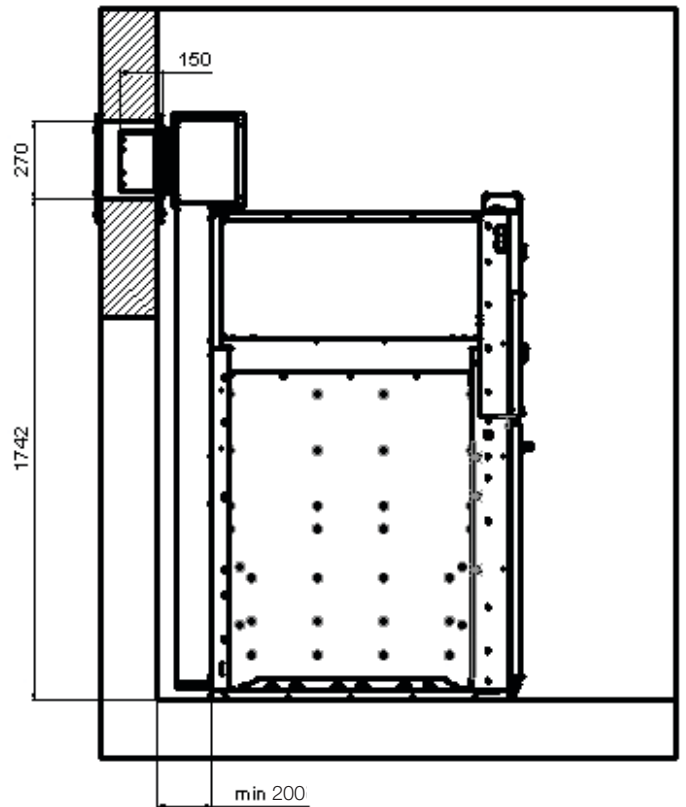

Figure 84. Side view

4.6.3 Gas exhaust filters 16 kA - Version BE

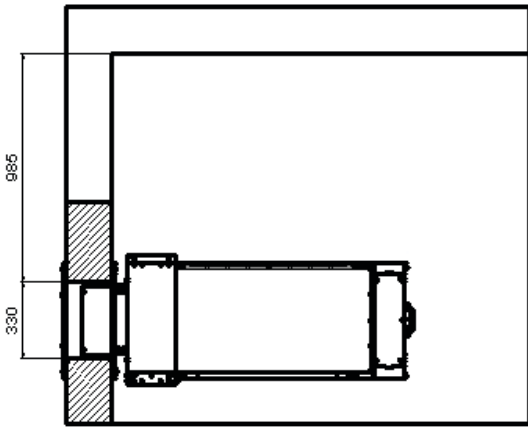

Figure 85. View from above

Example of raised rear outlet

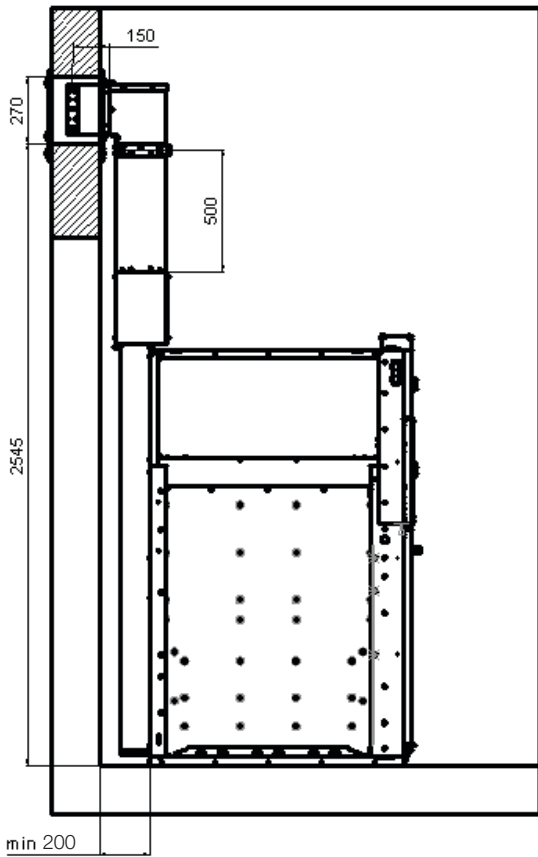

Figure 86. Side view

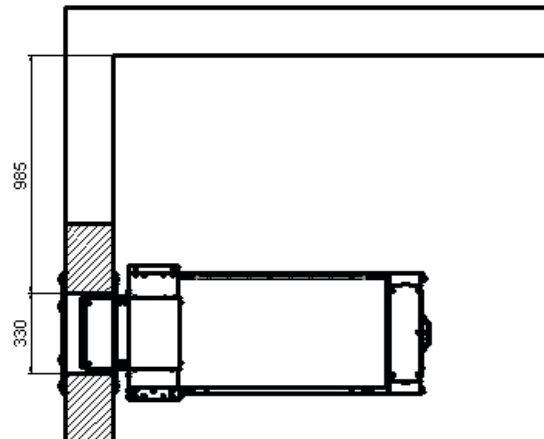

Figure 87. View from above

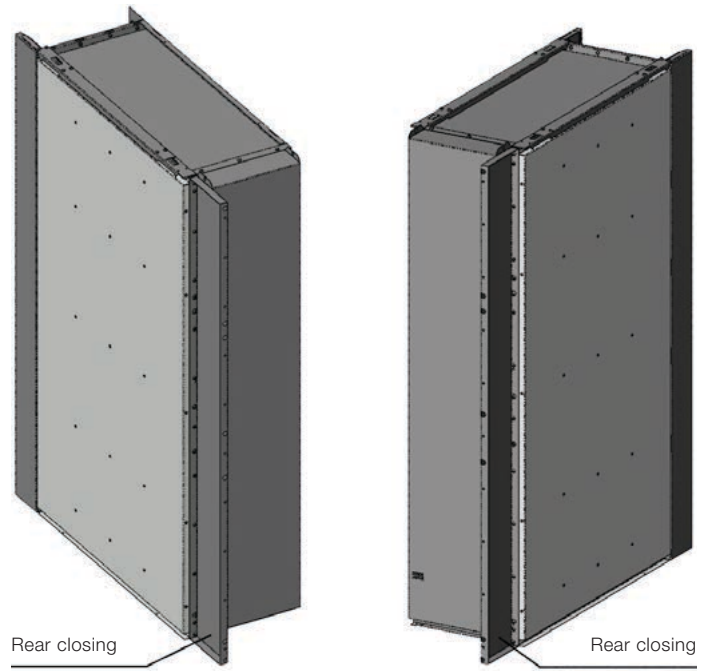

Figure 88.

4.7 Coupling to panels with withdrawable circuit-breaker and switch-disconnector (GSec)

The different design of the panels WBC/WBS/BME and the different height of the omnibus busbars not allowed direct coupling with the panels with switch-disconnector and/or removable circuit breaker both H = 1700 mm and H = 2000 mm.

Adapter panels have been created for this type of compartment so as to allow the busbars to be connected. The height of the adapter panel is 2000 mm.

The adapter panel keeps all the characteristics of a standard panel and can therefore be used as an incoming/outgoing unit.

The available adapter panels are:

Unit	Width (mm)	Weight ⁽¹⁾ (kg)
SDC	500	220
SFC	500	225
SFV	500	225
SBC ⁽¹⁾	750	380
DRC	500	145

⁽¹⁾ Estimated weight, considering the base unit with 630 A busbars, without TA, TV and fuses

⁽¹⁾ Can be coupled only on the left side of WBC/WBS/BME units with withdrawable circuit-breakers

Table 6. Adapter panels

An adapter panel allowing UniSec switchgear to be coupled to the other ABB switchgear (UniMix and UniSwitch) is available on request.

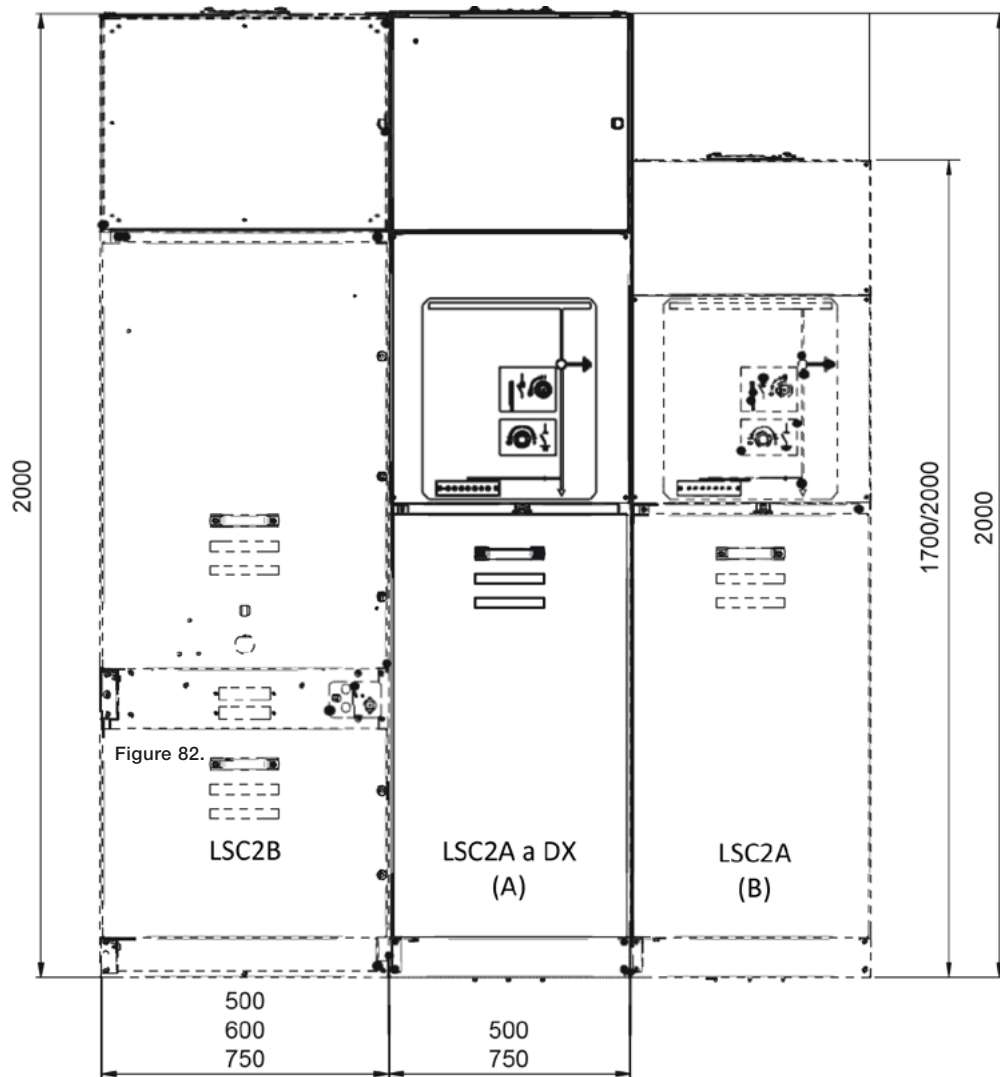

Figure 89.

5. Cable connections

5.1 Installing the cables



NOTE

The position of the medium voltage cables are positioned L1, L2 and L3 front to back.

5.1.1 Installing the cables

Parts

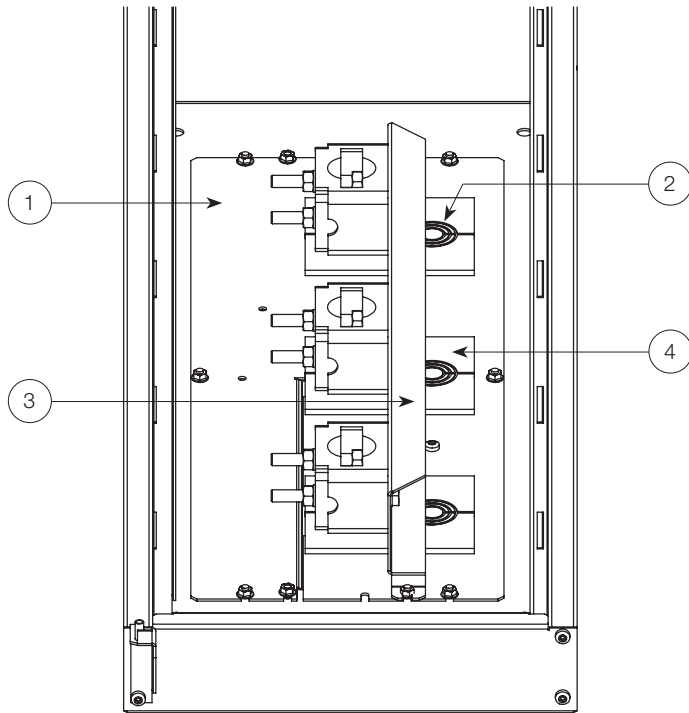

Figure 90. Parts

- 1. Floor sheet
- 2. Fairleads
- 3. Cable guide spline
- 4. Cable clamping screw



NOTE

The clamping screws are optional.

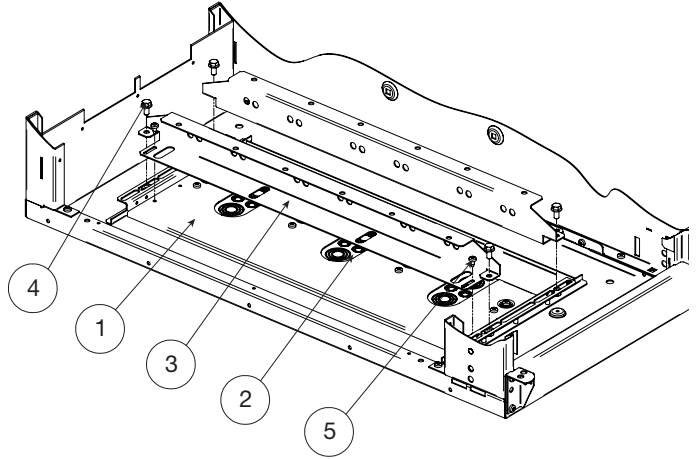

Figure 91. Medium voltage cable cover

- 1. Cable cover
- 2. Cable seal
- 3. Cable support
- 4. Hexagonal nuts with flange 9ADA289 M6 - steel 8 A2F
- 5. Cheese-head Torx plus screw. Screw M6x12 Fastite200005HQ -BA

Operations

1. Dismantle the cable clamps, cable guide splines, fairleads and the floor sheet
 - a) Unscrew the eight bolts on the floor and remove the bottom plates.

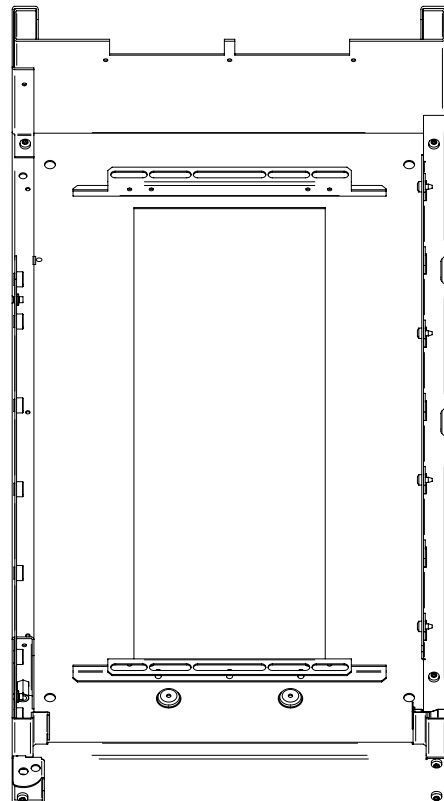

Figure 92. Dismantling completed

2. Cables

- a) Pull the cables through the open bottom into the unit. Measure and cut the cables to sufficient length, taking into consideration the installation of the cable terminations and cable terminals.
- b) Adapt the fairleads to the cable diameter and fit them onto the cable.

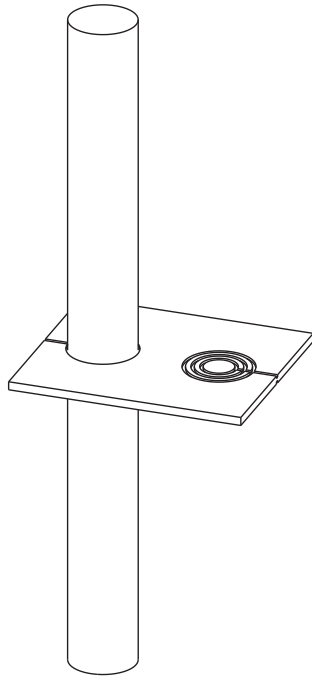

Figure 93. Cables and reducer rings

- c) Prepare the cable insulating ends and mount them on the cable cores according to the manufacturer's instructions.
- d) Connect the cables to the cable terminals as shown in Figure 94.

In a switch-fuse combination, the maximum terminal width is 30 mm.

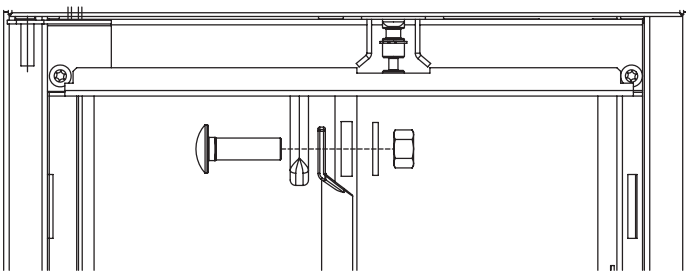

Figure 94. Connecting the cables

3. Cable clamps

- a) Remove 2 nuts (per phase) from the left hand side of the cable clamps.
- b) Remove the loose sides of the cable clamps.
- c) Insert the floor plates, fairleads, cable clamps and cable guide splines, together with 8 nuts, on the floor of the unit as shown in Figure 95.

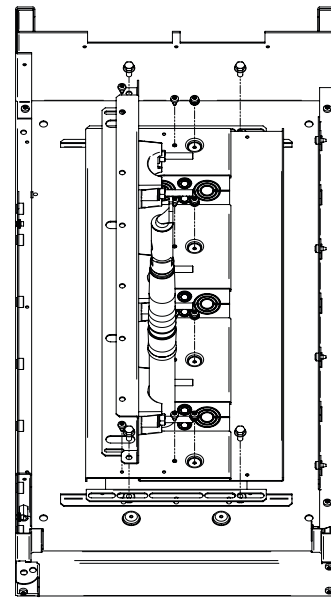

Figure 95. Installation of the floor plates, cable guide splines, cable clamps and fairleads

- d) Screw up all eight nuts.



NOTE

With SBC-W, the circuit-breaker can be removed as indicated in the Operation manual.



NOTE

In the case of a circuit-breaker, fit the floor plates as far apart from each other as possible so that the cables can be fitted directly to as vertical a position as possible.



NOTE

During mounting of the power cables, check that earth connection passes through the toroid (see figure below).

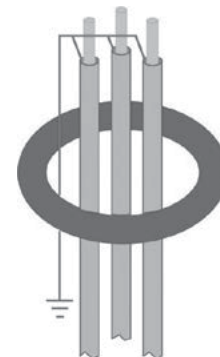

Figure 96.



NOTE

Check that P1 contacts of the toroid is mounted on supply side of the plant.

4. Cable clamps

a) Re-install the loose parts as shown in Figure 97.

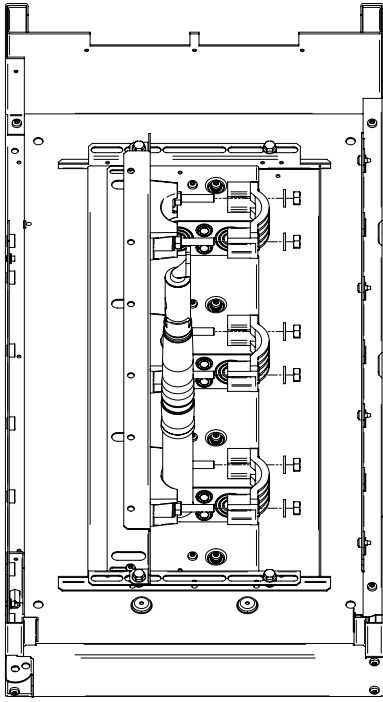

Figure 97. Installing the loose parts of the cable clamps

b) Tighten all 6 nuts.



NOTE

Tighten to the correct torque! See the tightening torques table at the end of the manual!

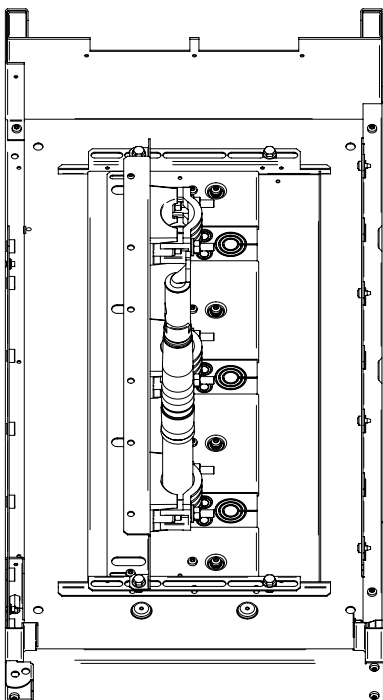

Figure 98. Cables ready

5.1.2 Installing the cables in the RLC unit

RLC unit cable compartment

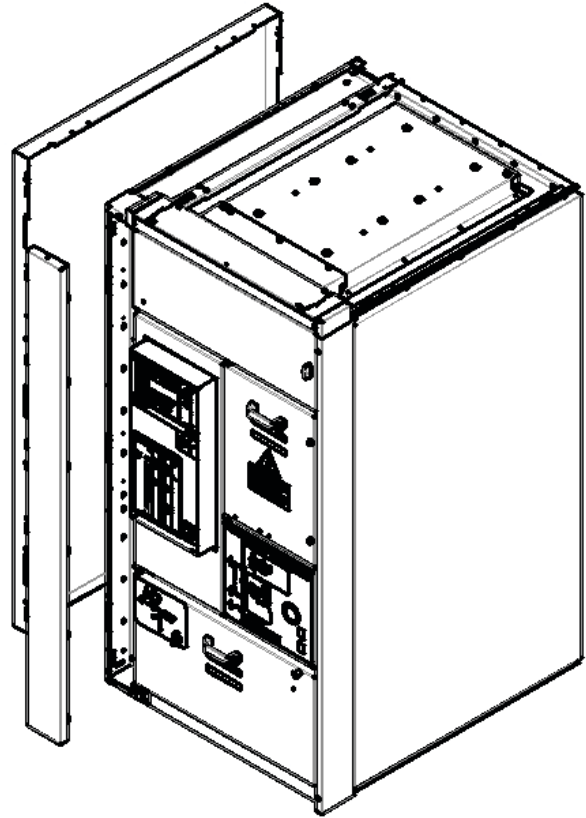

Figure 99. Cable compartment

Open the RLC cable compartment.

1) Unscrew at the top of the RLC front cover, lift it and remove the front RLC cover.

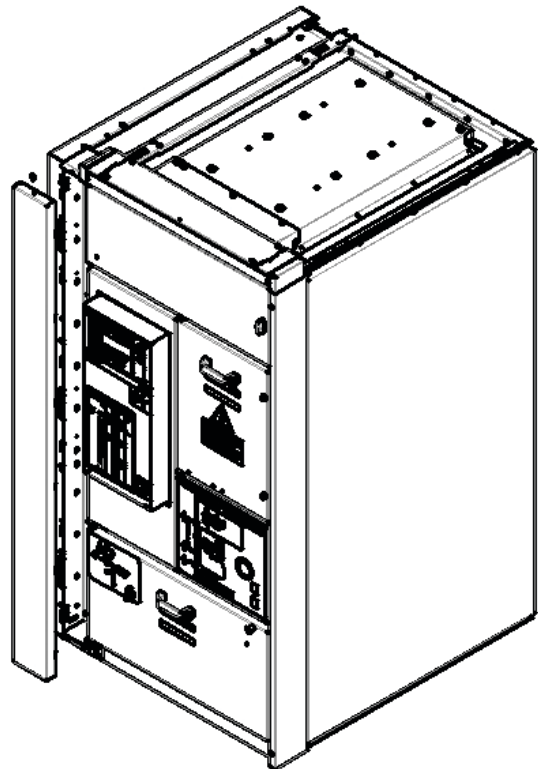

Figure 100. RLC front cover

2) Unscrew the top and back part of the RLC side cover, lift it and remove the RLC side cover.

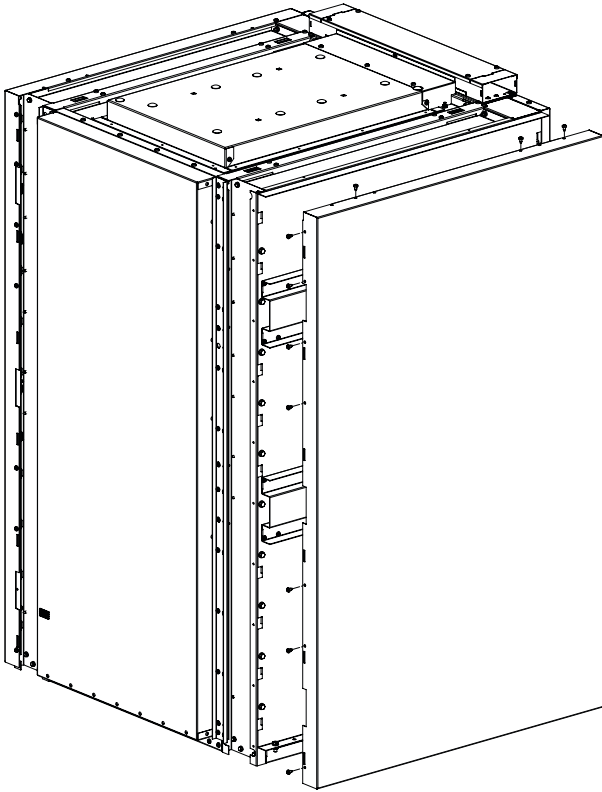

Figure 101. RLC cover

4) Unscrew, lift and remove the cable protection sheet of the RLC unit.

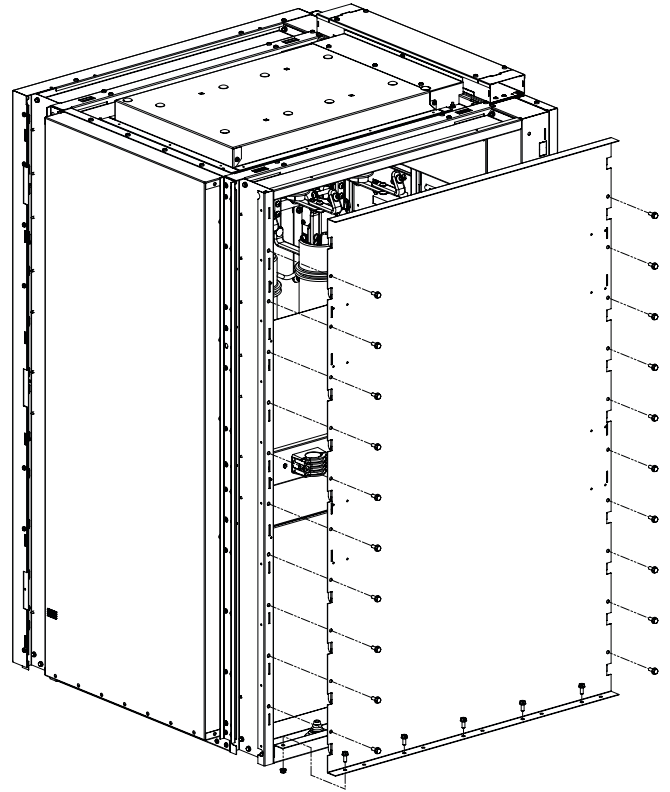

Figure 103. RLC internal cover

3) Unscrew, lift and remove the two metal sheets.

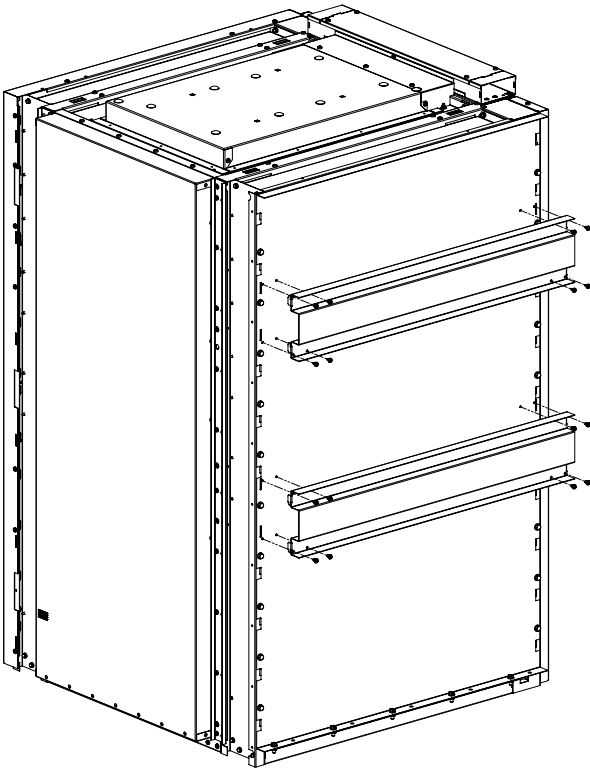

Figure 102. RLC transversal part

Connect the MV cables.

1) Cut the cable glands at the bottom of the RLC unit according to the cable diameter and fix the cables in the centre of the RLC unit to the locking part.

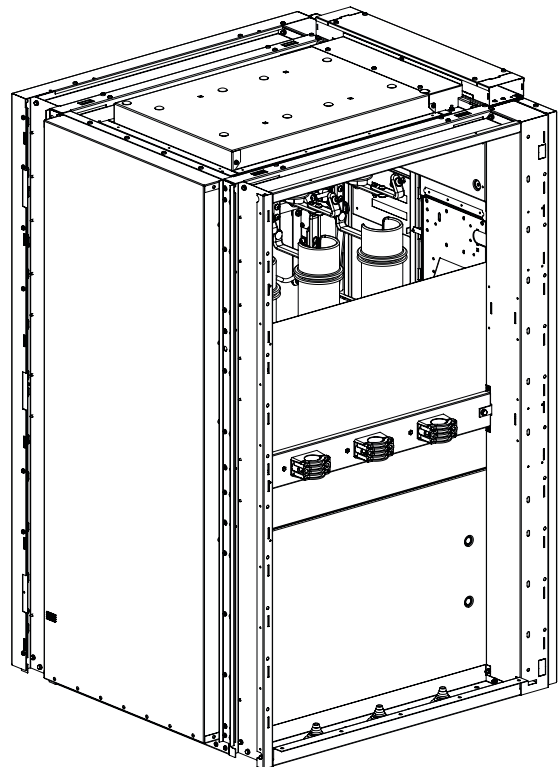

Figure 104. RLC unit cable locking parts

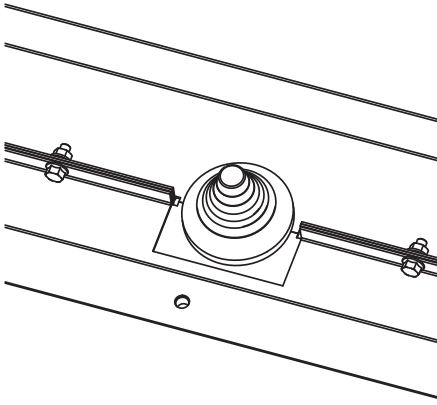

Figure 105. Cable glands on the bottom of the RLC unit

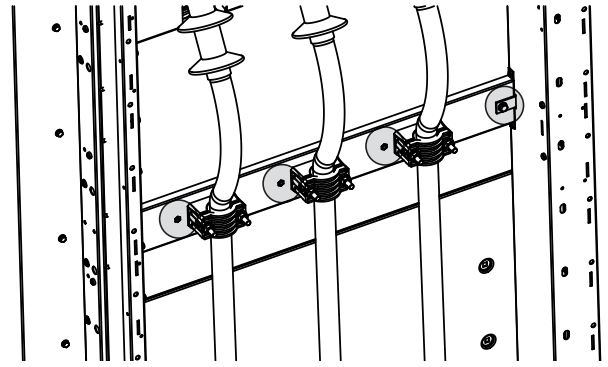

Figure 108. RLC unit earthing cable terminals

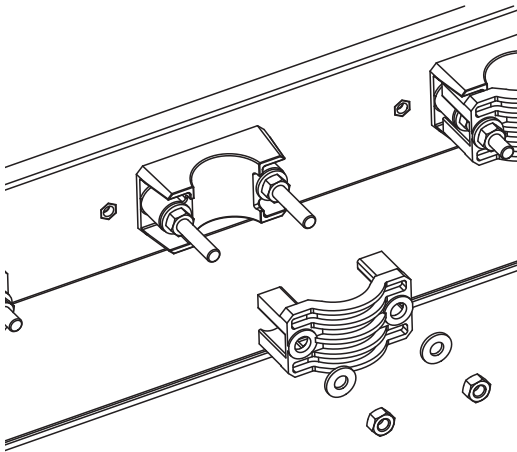

Figure 106. Exploded drawing of the cable locking parts on the bottom of the RLC unit

2) Connect the cables to the circuit busbar.

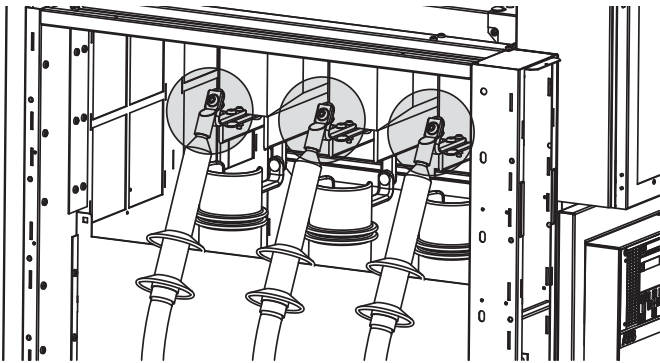

Figure 107. RLC unit cable terminal connections

3) Connect the cable earthing screen beside the plastic locking devices.

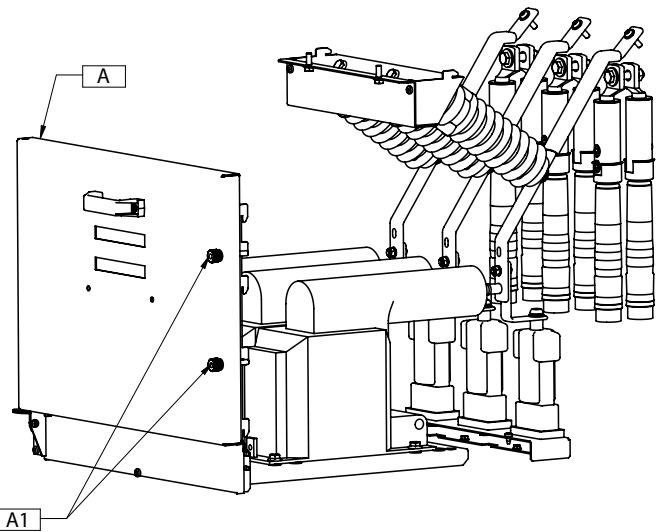

Figure 109.

b) If necessary, remove the lower front cover by unscrewing screws C1 and C2.

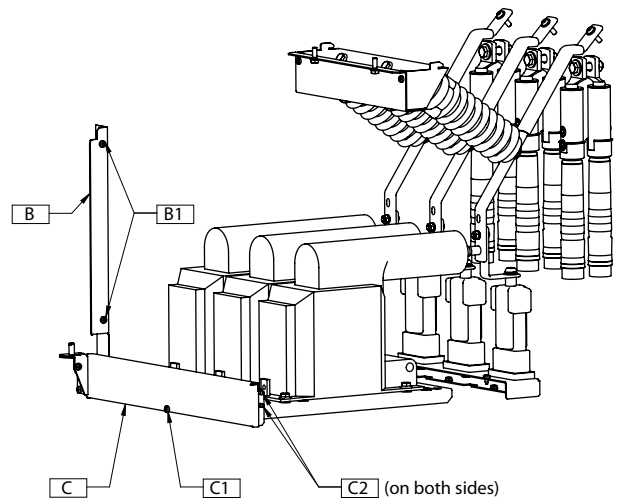

Figure 110.

- c) If supplied, remove plate D of the voltage transformers (VT) by unscrewing screws D1 and D2 (depend on the type of VT).
- d) If supplied, remove surge arrester E by unscrewing screws E1, E2 and E3.

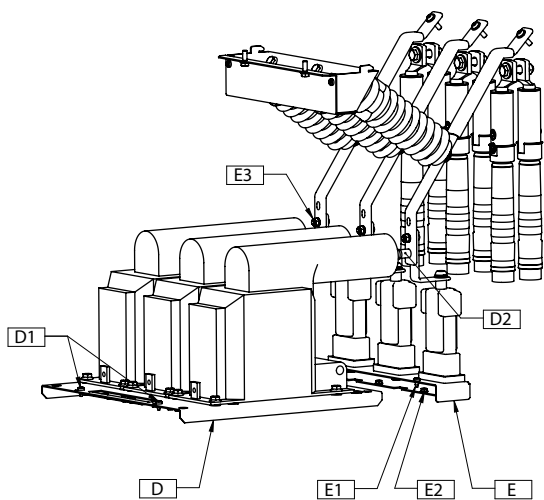

Figure 111.

- e) Connect the MV cables H using the H1 bolts.

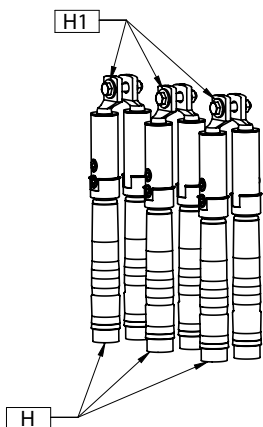



Figure 112.

NOTE
 If there is more space, the circuit-breaker compartment plate can be dismantled.

- f) Re-assembly of all components.

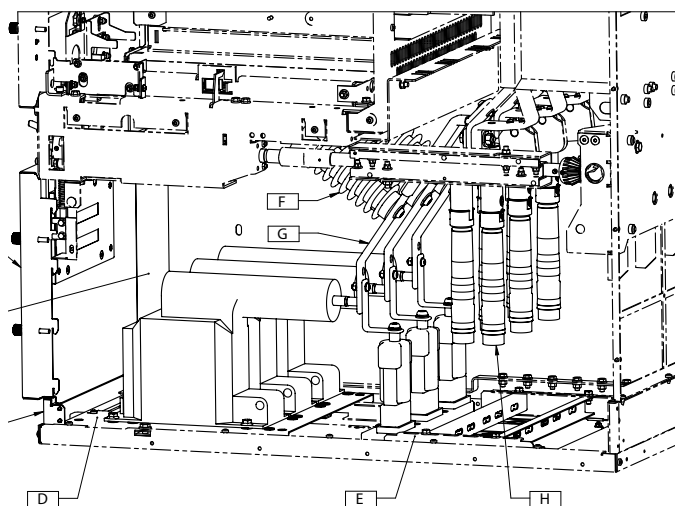

Figure 113.

Cable connections

	Panels	Width	Maximum quantity of cables per phase	Max cross section of cables (mm ²)
LSC2A	SDC	375	1 ⁽¹⁾	400
		500	1	630
			2	300
		750	1	400
			2	300
	SFC	375	1	95
		500	1	95
		750	1	95
	SBC/SBC-W	750	1	630
			2	300
	HBC	500	1	630
2			300	
DRC	375	1 ⁽¹⁾	400	
		1	630	
	500	2	300	
UMP	750	1	400	
		2	300	
RLC/RRC	190	1	400	
LSC2B	WBC/BME	600	1	630
			2	400
			4	300
	750	2	400	
		4	240	

⁽¹⁾ 2 (two) 300 mm² cables @ 12 Kv

Table 7. Cable connections

5.2 Control cables

The internal cables between units are easily laid through openings in the side walls of the auxiliary circuit compartment.

Depending on the delivery times, there are two different procedures for supplying the connection cables of the units:

- Cables not included
- Cables supplied rolled in a bundle in the auxiliary circuit compartment.

Table 8 gives the correct torques for the terminal blocks.

Terminal Blocks		
Width of terminal box (mm)	Cross-Section of cable (mm ²)	Tightening Torque (Nm)
5	0.2-2.5	0.4-0.6
6	0.2-4	0.5-0.8
8	0.5-6	0.8-1

Table 8. Terminal Blocks

The options available for control cable entry are:

- Side duct at both ends of the switchgear.
- A duct can also be placed on the roof of the switchgear to support the incoming cables, for example, from an overhead cable ladder.

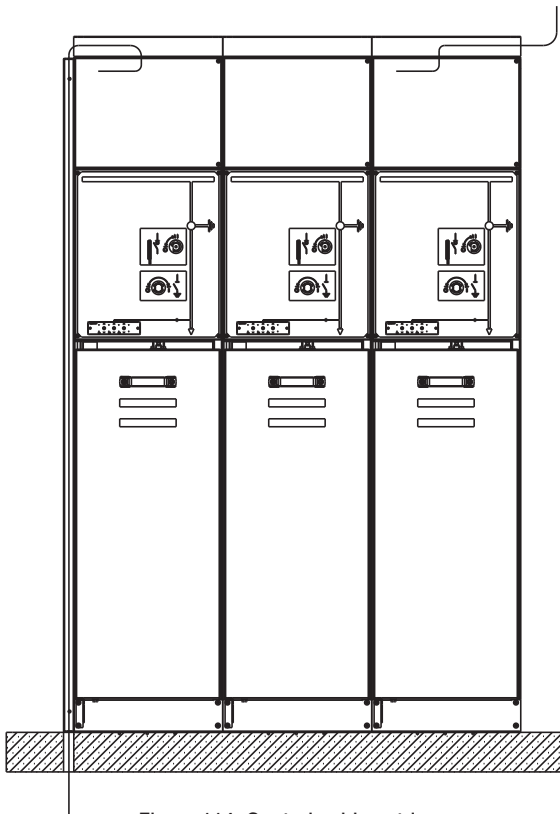

Figure 114. Control cable entries

5.3 Earthing the switchgear

Each unit is fitted with earthing busbars that run longitudinally in the lower front part of the unit. These busbars must be connected together as shown in chapter 5.3.1. The station earthing system must be connected to the end unit of the switchgear. If the switchgear consists of more than 8 units, it is advisable to connect the station earthing system to both end units. The external station earthing connection point inside the unit is shown in Figure 118. All the apparatus is connected to the earthing busbar via the switchgear housing. The interconnection between units is capable of carrying the rated short-time and peak withstand current for the earthing circuit.

5.3.1 Installing the earthing busbar

Installation operations are as follows:

- Unscrew the right-hand screw (when there is another unit on the right side) and loosen another two screws. Then move the busbar towards the adjacent unit on the left.

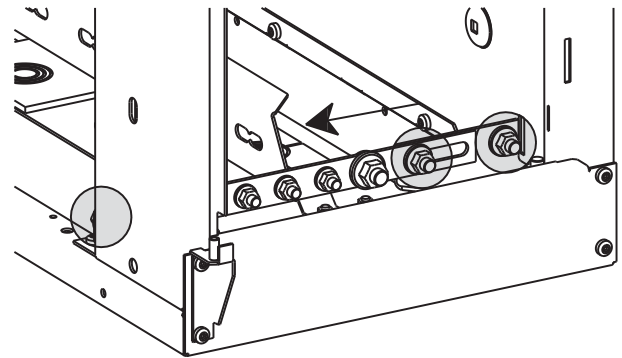

Figure 115. Busbar moved towards the adjacent unit on the left

- Move the busbar from the unit to the right (when there is another unit on the right). Add the screw on the right and screw up all the screws with the correct torque.

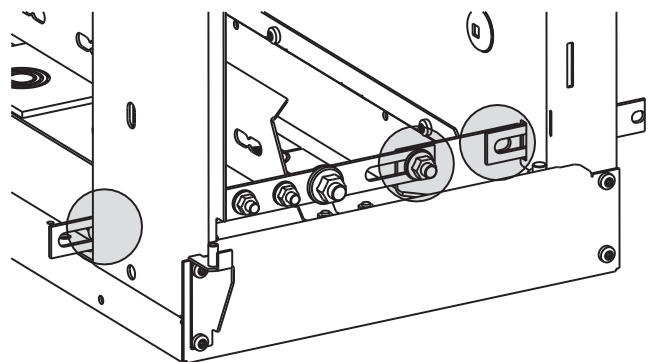

Figure 116. Busbar moved from the adjacent unit to the right

c) Earthing busbar installed.

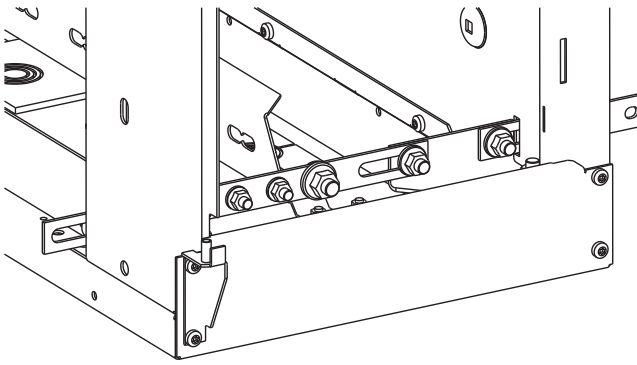

Figure 117. Earthing busbar installed

d) The earthing cables can be mounted with bolts, as shown in Figure 118. The M12 bolt, marked with the earthing symbol, is reserved for the external station earthing system, the other M10 bolts (3 pieces) for the cable sheaths or other earthing systems.

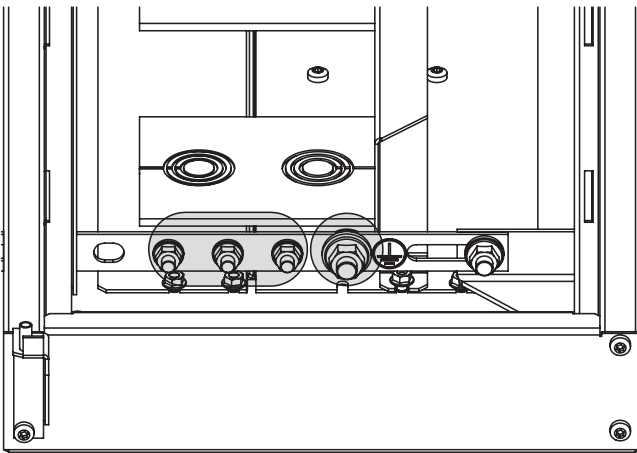

Figure 118. Positions of the earthing cables

e) Connect the earthing cables to the main earthing busbar of the SBR functional unit.

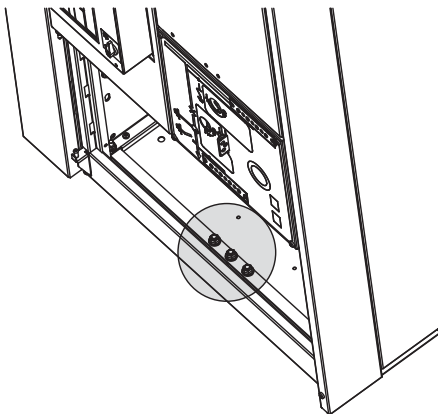

Figure 119. Main protection earthing busbar of the SBR unit



NOTE

Tightening must be carried out with the correct torque.

5.3.2 Main earthing circuit connections between the panels of the SBR functional unit

a) Install the protection busbar conductor between panels of the SBR functional unit.

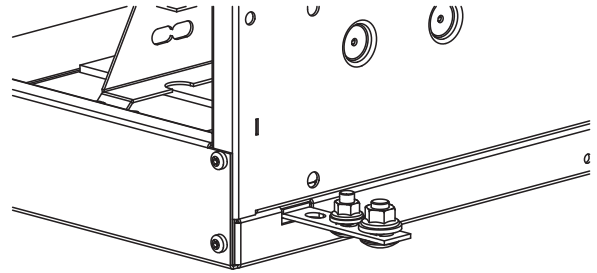

Figure 120. SBR unit protection busbar conductor

b) Connect the L-shaped protection conductor between the SBR unit and other panels.

5.3.3 Connection of the main earthing circuit for WBC – WBS units

a) Install the earthing busbar between the units and connect it to the main earthing circuit.

5.4 Final installation work

Checkpoints

- Check the painted parts of the switchgear for any damage, touching up where required.
- Check the bolt connections and tighten where required (especially those made during on-site installation of the busbars and earthing system).
- Clean the switchgear thoroughly.
- Remove all foreign objects from the units.
- Correctly replace all coverings, etc. removed during the installation and connection operations.
- Any remaining openings in the switchgear housing must be closed if they are no longer needed.
- Check that the isolating contacts and interlocking mechanisms operate correctly and, if necessary, grease them again with Isoflex Topas NCA 52.
- Insert any withdrawable circuit-breaker parts and connect them to the control cabling.
- Close the unit doors properly.

A. Tightening torques for steel screws and nuts/bolts

Nuts and bolts

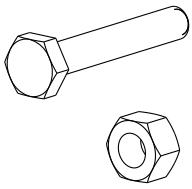

Type	Max. tightening torque [Nm]	
	Steel class 8.8	
M4	3	
M5	5	
M6	9	
M8	22	
M10	45	
M12	75	
M16	185	

Hexagonal-head bolts with flange

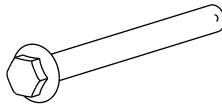

Type	Max. tightening torque [Nm]	
	Steel class 90	
M5	9	
M6	16	
M8	34	
M10	58	
M12	97	
M16	215	

Cheese-head socket screws

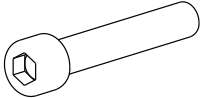

Type	Max. tightening torque [Nm]	
	Steel class 8.8	
M4	2	
M5	4	
M6	8	
M8	12	
M10	35	
M12	50	
M16	110	

Cheese-head Torx Fastite screw

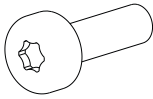

Type	Max. tightening torque [Nm]	
	Steel class 8.8	
M6	20	

The values in the tables must be used unless the torque is specified in the table of joint types.

Socket-head screws and round-headed Torx

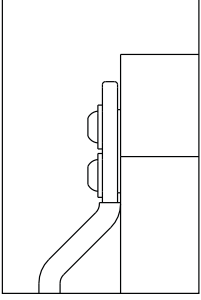
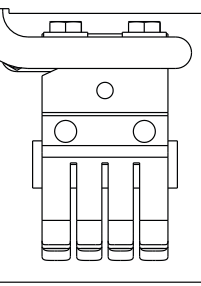
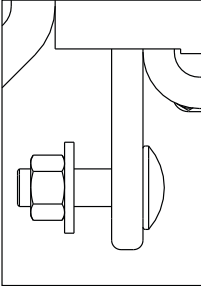
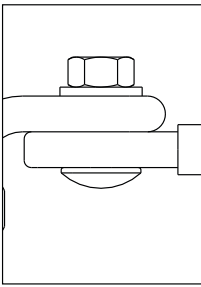
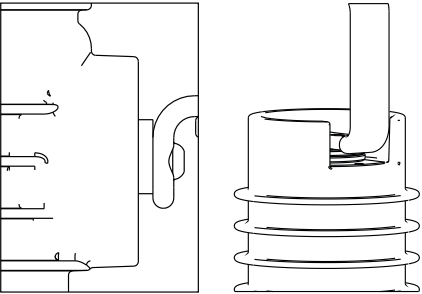

Type	Max. tightening torque [Nm]	
	Steel class 8.8	Steel class 10.9
M4	2	2
M5	4	4
M6	8	8
M8	12	12
M10		30
M12		60

Joint type		Tightening torque [Nm]						
		M5	M6	M8	M10	M12	M16	
1	Bolts mounted on the CT, TPU type 	min	2.8		16		56	
		nominal						
		max	3.5		20		70	
2	Bolts mounted on electrical pliers 	min		8				
		nominal		9				
		max		10				
3	Cable connection nut 	min			18	35	65	170
		nominal			20	40	70	180
		max			22	45	75	190
4	Busbar connections 	min			18	35	65	170
		nominal			20	40	70	180
		max			22	45	75	190
5	Bolts mounted on the circuit-breaker 	min						
		nominal			30	40		
		max						

Joint type

			Tightening torque [Nm]					
			M5	M6	M8	M10	M12	M16
6	Bolts mounted on the mandolin CT	min						
		nominal				35		
		max						
7	Bolts mounted on the post insulator	min					25	
		nominal			9	20	30	
		max					31	
8	Bolts mounted on the connection and switching busbar	min					56	
		nominal				35	60	
		max					70	
9	Bolts for mounting CT	min						
		nominal				40		
		max						
10	GSec and busbar	min						
		nominal				35		
		max						

B. Tools required for installation

Torx wrench

- TX30 Torx wrench

Allen wrenches

- 5 mm
- 6 mm
- 8 mm

Socket wrenches

- 10 mm
- 15 mm
- 17 mm
- 19 mm

Ring spanner

- 13 mm

Notes

A series of horizontal dotted lines for writing notes.

For more information please contact:

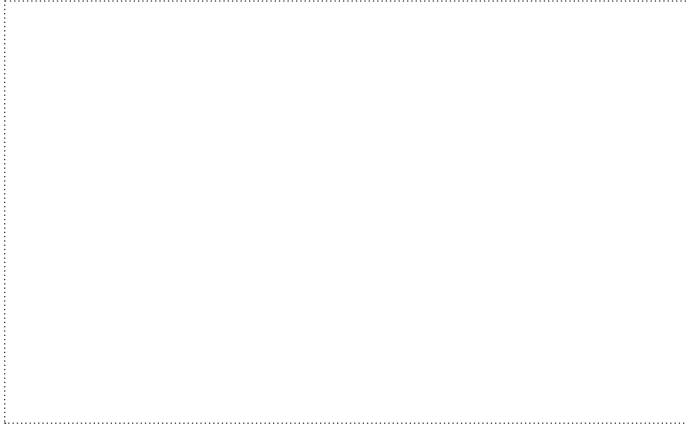

Your sales contact: www.abb.com/contacts

More product information: www.abb.com/productguide

The data and illustrations are not binding. We reserve the right to make changes in the course of technical development of the product.

© Copyright 2015 ABB.
All rights reserved.