

Power^{IT} – Low voltage switchgear MNS

Technical information



General technical description	1
Mechanical design	2
Modules with Direct Connections to the Main Busbar System	3
Modules with Connections to the Vertical Busbar System	4
- Fixed-Technique	4.1
- Plug-In- and Removable Technique	4.2
- Withdrawable -Technique	4.3
Empty cubicles for free project engineering	5

Technical Reservations

The information given in this publication is subject to technical modifications.



Fields of application

MNS systems are suitable for applications in all fields concerning the generation, distribution and use of electrical energy, e. g., they can be used as

- Main and sub-distribution boards for energy
- Motor current supply of Motor Control Centres
- Electronic cabinets for open and closed-loop control purposes
- in utility companies
- in power plants
- in oil refineries
- on off-shore drilling platforms
- on ships
- in production facilities
- in sewage management
- in buildings for other than dwelling purposes

System features

The Modular Low-Voltage Switchgear System has proven its worth for many years worldwide. At the same time, it constitutes a safe investment for the future due to its continuous further development. The high flexibility of the MNS system results from a framework construction with maintenance-free bolted connections which can be equipped as required with standardized components and can be perfectly adapted to each application. The consistent application of the modular principle both in electrical and mechanical design permits optional selection of the structural design, interior arrangement and degree of protection according to the operating and environmental conditions.

The design and material used for the MNS system largely prevent the occurrence of electric arcs, or provide for arc quenching within a short time. The MNS-System complies with the requirements laid down in VDE0660 Part 508 as well as IEC 1641 and was furthermore subjected to extensive accidental arc tests by an independent institute. Type test certificates are available. In these tests, the effects of the striking accidental arcs were limited to their places of occurrence, the operation of neighbouring withdrawable modules was not affected. After cleaning, the withdrawable module compartments were fully operative again, mechanically interlocked withdrawable modules remained firmly within the cubicle, and even in isolating position, none of the substance indicators located in front of the cubicle were ignited.

All plastic parts used in the MNS system are free of CFC's or halogens, they are flame-retardant and self-extinguishing.

The MNS system offers the user many alternative solutions and notable advantages in comparison with conventional-type installations:

- Compact, space-saving design
- Back-to-back arrangement
- Economic energy distribution in the cubicles
- Easy project and detail engineering through standardized components
- Comprehensive range of standardized types
- Various design levels depending on operating and environmental conditions
- Easy combination of the different equipment systems, such as fixed and withdrawable modules, in a single cubicle
- Arc-proof design possible (standard design with fixed module design)
- Earthquake-, vibration- and shock-proof design possible
- Easy assembly without any special tools
- Easy conversion and retrofit
- Largely maintenance-free
- High operational reliability and availability
- Optimum personal protection



Technical standards

The MNS system is a type-tested switchgear assembly (TTA) in accordance with: IEC 439-1, EN 60 439-1, VDE 0660 part 500, BS 5486 Part 1 and UTE 63-410.

The erection and connection of the switchgear systems is governed by IEC 364 and DIN VDE 0100, operation is subjected to DIN VDE 0105.

Operating and environmental conditions

MNS type switchgear is suitable for installation in closed locations for electrical equipment and other operating facilities in accordance with their degree of protection (up to IP 54).

Ambient temperature

Short-time maximum value	+ 40 °C
Maximum mean value over a 24-hour period	+ 35 °C
Minimum value	- 5 °C

An adaption to other ambient temperatures is possible under consideration of the reduction factors.

For meters, measuring instruments, protective relays, etc., the manufacturer's special instructions must be observed.

Atmospheric conditions

Normal climatic service conditions to IEC 439-1, EN 60439, VDE 0660 part 500. Relative humidity 50 % at 40 °C.

It must be ensured that indoor conditions are maintained for the place of installation. Moisture condensation on the switchgear components must be prevented by suitable measures such as heating and/or ventilation.

Installation up to 1000 m above sea level for higher locations the reduction factors has to be taken into consideration.

Design for extreme operating conditions

- in tropical areas
- in earthquake-prone areas
- in shelters
- in shipbuilding
- in offshore switchboards

A suitable surface treatment is applied to ensure tropicalization.

With the aid of accessories and strengthened parts the MNS system meets the safety requirements for earthquake-prone areas.

By using suitable shock isolators, an MNS cubicle equipped with a circuit-breaker and fuse switch disconnectors in strip design complies with the shock conditions class 0.63/6.3 of the Federal Authority for Civil Defence for installation in civil defence shelters.

The standard version of the MNS system has been tested and approved under the supervision of German Lloyds and Lloyd's Register of Shipping for use in shipbuilding. The switchgear installations are vibration-proof for a frequency range between 5 and 100 Hz.



Technical Data

Standards	Type tested switchgear assemblies (TTA)*	IEC 439-1, EN 60 439, DIN VDE 0660, part 500, BS 5486, UTE 63-412	
Test certificates	Germanischer Lloyd, Hamburg (shipping) ASTA; Great-Britain (resist. to accidental arcs acc. to IEC 1641, VDE 0660 part 508) Federal Ministry for Regional Planning Building and Urban Development, Bonn (shelters) DRL German Research Institute for Aerospace e.V., Jülich, Earthquake Test for Security Areas in Nuclear Power Stations		
Electrical data	Rated voltages	Rated insulation voltage U_i Rated operating voltage U_e Rated impulse withstand voltage U_{imp} Overvoltage category Degree of pollution Rated frequency	1000 V 3~, 1500 V- ** 690 V 3~, 750 V- 8 kV III 3 up to 60 Hz
	Rated currents	Busbars: Rated current I_e Rated peak withstand current I_{pk} Rated short-time withstand current I_{cw} Distribution bars: Rated current I_e Rated peak withstand current I_{pk} Rated short-time withstand current I_{cw}	up to 6300 A up to 250 kA up to 100 kA up to 2000 A up to 165 kA up to 86 kA
Mechanical characteristics	Dimensions	Cubicles and supporting structures Recommended height Recommended width Recommended depth Basic grid size Hinged frame for accommodation of electronic subracks	DIN 41488 2200 mm 400, 600 , 800, 1000 , 1200 mm 400, 600 , 800, 1000, 1200 mm E = 25 mm acc. to DIN 43660 DIN 41494, sheet 1, ASA C 83.9
	Surface protection	Frame Internal subdivision Transverse section Enclosure	Alu-zinc coated Alu-zinc-coated Galvanized Paint RAL 7035, light-grey
	Degrees of protection	According to IEC 529 or DIN 40050	IP 00 up to IP 54
	Plastic components	CFC-free, halogen-free flame-retardant, self-extinguishing	DIN VDE 0304 part 3 IEC 707
	Internal subdivision	Cubicle-cubicle Busbar compartment-cable compartment Busbar compartment-equipment compartment Equipment compartment-cable compartment Compartment bottom plates	
Extras	Paint	Enclosure	Special colours (standard RAL 7035)
	Busbar system	Busbars	Insulated (standard is bare)
	Special qualification	Tests	see test certificates listed above

* Definition TTA: Switchgear assembly corresponding to a large degree with the original type of switchgear assembly type-tested in accordance with these standards.

** Depending on the electrical equipment

Frame

The basic elements of the frame are C-sections with holes at 25 mm intervals according to DIN 43660. All frame parts are secured maintenance-free with tapping screws or ESLOK-saved screws. Based on the basic grid size of 25 mm frames can be constructed for the various cubicle types (see chapters 3 - 6) without any special tools.

Single or multicubicle switchgear assemblies for front or front and rear operations are possible.

Enclosure

Different designs are available, depending on the enclosure required:

An open design with a protective rod as barrier on the front side, optionally with rear and side panels, a panel design (front IP 30), and a totally enclosed cubicle with IP 54, with the following front side options:

- single equipment compartment door
- double equipment compartment door
- equipment and cable compartment door
- module doors and/or withdrawable module covers and cable compartment door
- hinged frame

The hinged frame is designed to accommodate electronic subracks and instrument plates (may also be used as equipment frame). The mounting area of the hinged frame can be covered with an additional door with or without a window.

The bottom side of the cubicle can be provided with floor plates. With the aid of flanged plates, cable ducts can be provided to suit all requirements.

Doors and cladding can be provided with one or more ventilating louvers, roof plates can be completely ventilated (valid for IP 40 and IP 41).

Switchgear cubicles in withdrawable design are always totally enclosed.

Internal subdivision

Depending on the requirements, a frame structure is selected which can be subdivided into the following compartments (functional areas):

- equipment compartment
- busbar compartment
- cable compartment

The equipment compartment holds the equipment modules, the busbar compartment contains the busbars and distribution bards, the cable compartment accommodates the incoming and outgoing cables (optionally from above and from below) and the wiring required for connecting the modules as well as the supporting devices (cable mounting rails, cable connection parts, parallel connections, wiring ducts, etc.).

The functional compartments of a cubicle as well as the cubicles themselves can be separated by partitions. Horizontal partitions with or without ventilating louvers can also be inserted between the modules.

Internal subdivision reduces the effect of arc faults outside their point of origin to a minimum.

Busbars

The busbars are arranged in the rear section (busbar compartment) of the switchgear cubicle horizontally in two selectable levels. Double busbar systems are located at the upper and lower level, while single busbar systems are arranged either at the upper or lower level. The busbars of both levels can be of the same or different cross-sections.

Separate, parallel or coupled operation is possible. 2 or 4 conductor elements are installed per phase, 2 conductor elements with back-to-back cubicles.

The busbars are made of copper (Cu) 30 x 5, 30 x 10, 60 x 10 and 80 x 10 [mm].

In the case of multicubicle switchgear systems, the busbars are divided into sections corresponding to the size of the switchgear shipping units. Units having busbars of different cross-sections can be coupled together. Cubicles for front and rear operation have a common busbar system with conductor cross-sections of 30 x 10, 60 x 10 and 80 x 10 [mm] made of Cu.

Protective and neutral conductor bars

The MNS system can be alternatively equipped with a 4- or 5 conductor bar system. Apart from busbars and distribution bars, the 4-conductor system includes a protective neutral bar (PEN). The 5-conductor system has an additional neutral conductor bar (PE + N).

The protective/neutral conductor bar is mounted horizontally directly to the frame in the lower section of the equipment compartment and cable compartment, if necessary. Parallel to this, the neutral bar is mounted on insulators. The lengths of the bars correspond to the transport units of the cubicle.

The protective/neutral connecting bar is arranged vertically in the cable compartment. Parallel to this, the neutral connecting bar is mounted on insulators. The bar lengths are matched to the height of the cubicle.

All PE, N and PEN busbars and connecting bars are perforated according to a grid system which permits the bars to be mounted in the cubicle and the outgoing cables and wiring to be connected as required.

Protective conductors with cross-sections up to 35 mm² can be directly connected to the terminal carriers of the standard fixed modules as well as to the withdrawable module condapter for 8E/4 and 8E/2 modules.

Wiring ducts, cable mounting equipment

A control cable duct is located in the upper cubicle section for installing the electrical equipment necessary for the supply of the auxiliary circuits within on cubicle and for accommodating the cross-links within one shipping unit or switchgear system. The front of this wiring duct is equipped with a mounting rail for installing electrical equipment of the snap-mounted type, e. g. control voltage m.c.b.'s.

For accommodating the connecting lines within cubicles or switchgear systems, additional vertical wiring ducts and mounting sections for cable installations are available.

Spaces or spare modules between individual modules are protected by covers.

In fixed-mounted and withdrawable design, the control cable duct in the upper, and the PEN busbar in the lower section of the cubicle are protected by a module door or front cover. The lower front cover contains ventilation louvers.

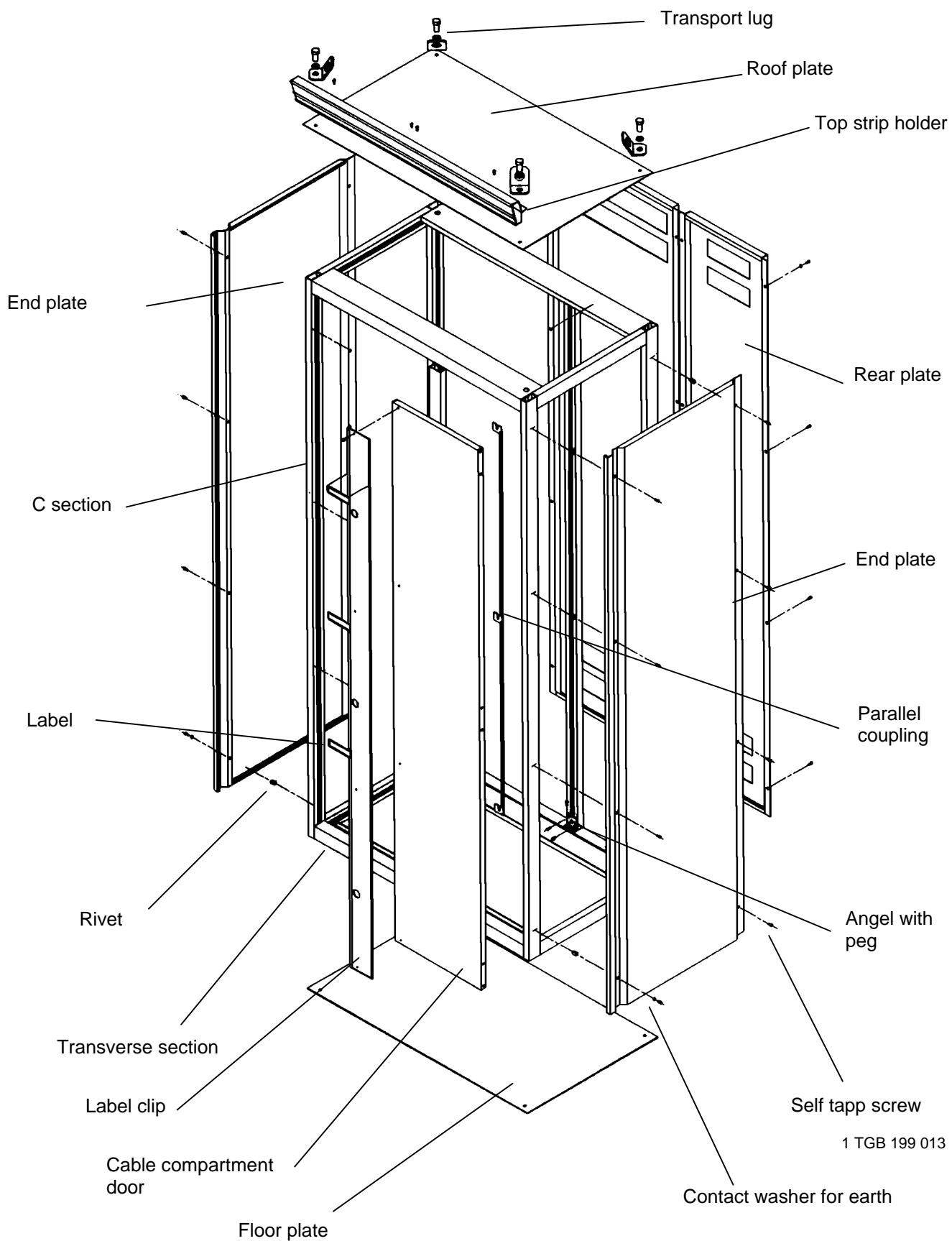

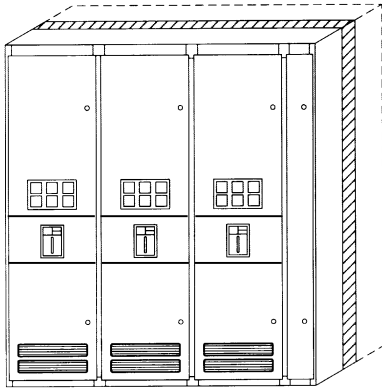

Switchgear cubicle for energy distribution with 3 equipment compartments for circuit-breakers, with busbar compartment and busbar connection compartment.

Cubicle structure

All incoming feeder, outgoing feeder and bus coupler cubicles include one switching device. These devices may be fixed-mounted switch disconnectors, fixed-mounted or withdrawable circuit-breakers in open or moulded-case design.

This type of cubicles is subdivided into equipment and busbar compartments, their size (H x W x D) is 2200 mm x 400 ... 1200 mm x 600 mm., depending on the size of the switchgear used. Cubicles with open-type circuit breakers up to 2000 A can be built in narrow design (W = 400 mm).

It is possible to interconnect cubicles to form shipping units with a maximum width of 3000 mm

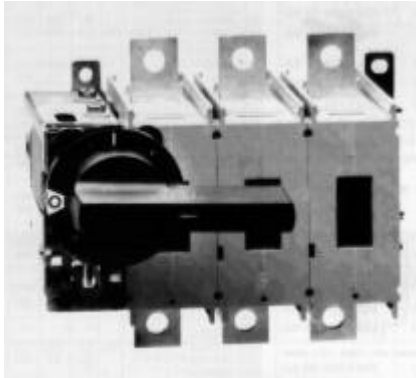

Switch-disconnector (OETL)

Switching devices

Switch-disconnectors up to 3150 A, moulded-case circuit-breakers up to 1600 A and open-type circuit-breakers up to 5000 A are provided as standard switching devices. The withdrawable versions include a fixed-mounted cassette with disconnecting contacts.

For circuit-breakers, electronic, microprocessor-controlled overcurrent releases, shunt, undervoltage and closing releases as well as motor drives, auxiliary contacts, lock and key interlocks are available offering a wide variety of possible applications.

The mechanical accessories of the cubicles include a measuring recess with a fold-out instrument panel and shock hazard protection covers. The doors have suitable openings for operation from outside. Current measurement and measuring voltage supply are available as electrical accessories.

Switch-disconnectors for 1000 A or more, moulded-case circuit-breakers for 630 A or more, and open-type circuit-breakers are directly connected to the busbars. Busbars or cables (up to 12 parallel cables) can be connected at the incoming and outgoing sides. Connection is made directly in the equipment compartment from above or below, however, cable connection from above is limited to 1600 A.

For mounting the cables to the frame, cable mounting rails are fitted if necessary. The electrical connections and mechanical installations are maintenance-free due to the use of ESLOK-saved screws. The built-in switching devices must be serviced according to the respective operating instructions.



Moulded case circuit-breaker (Isomax S)

DE 970531



Open-type circuit-breaker (Emax E)

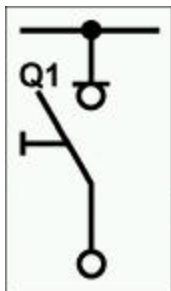

Switch-disconnector incoming/outgoing feeder



Switch-disconnector bus coupler

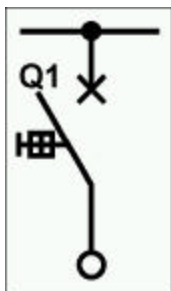

Circuit-breaker incoming/outgoing feeder, fixed

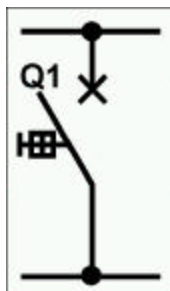

Circuit-breaker bus coupler, fixed

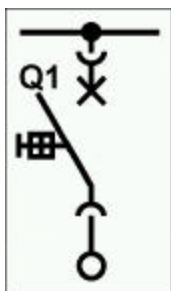

Circuit-breaker incoming/outgoing feeder, withdrawable

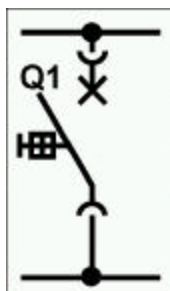

Circuit-breaker bus coupler, withdrawable

Standard modules

Switch disconnector (OETL)

Rated current A	Rated short-circuit breaking capacity at 400 V ~, cos φ = 0,95 A	Equipment compartment		
		Width 3-pole mm	Width 4-pole mm	Depth mm
1250	2500	600	800	400
1600	2500	600	800	400
2500	4800	600	800	400
3150	4800	600	800	400

Moulded case circuit breaker (ISOMAX S)

Rated current A	Rated short-circuit breaking capacity at 400 V ~, cos φ = 0,3/0,25 kA	Equipment compartment		
		Width 3-pole mm	Width 4-pole mm	Depth mm
630	50 up to 80	400, 600	600	400, 600, 800
800	50 up to 80	400, 600	600	400, 600, 800
1250	55 up to 80	400, 600	600	400, 600, 800
1600	55 up to 80	400, 600	600	400, 600, 800

Open type circuit breaker (Emax E)

Rated current A	Rated short-circuit breaking capacity at 400 V ~, cos φ = 0,3/0,25 kA	Equipment compartment		
		Width 3-pole mm	Width 4-pole mm	Depth mm
800 1250 1600 2000	E 1 and E 2	400	600	600
2500 3200	E 3	600	800	600
4000	E 4	800	800	600
5000 6300	E 6	1000	1200	600

For details, see the Technical Data Sheets

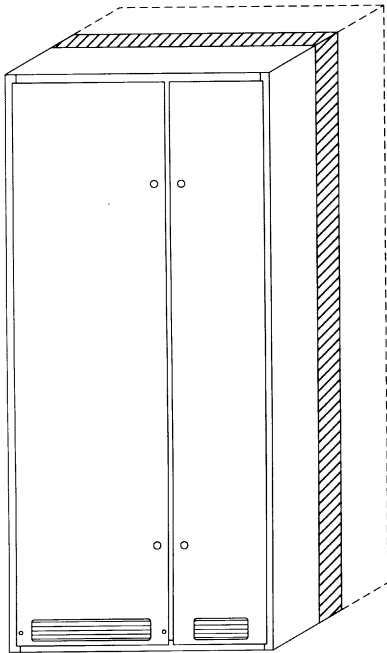

Switchgear cubicle for outgoing feeders in fixed module design with equipment, cable and busbar compartment

Cubicle structure

In the MNS system, components belonging to one functional group are assembled to form a simple mechanical and electrical module. Power and control modules are available.

Cubicles for plug-in, removable and withdrawable-mounted modules are divided into equipment, cable and busbar compartments. Their size (H x W x D) is 2200 mm x 800 / 1000 mm x 400 ... 600 mm.

Distribution bars

The distribution bars provide the connection between the busbars and the modules. They are arranged vertically in the busbar compartment. Distribution bars are single busbars with a rectangular cross-section of 50 x 5 [mm] or an angular cross-section 50 x 30 x 5 [mm] designed for plug-in connections. The distribution bars are made copper (Cu).

A maximum of two three- or four-pole distribution bar systems can be installed in a switchgear cubicle. The busbars can be arranged over the entire cubicle height, or over partial heights, or can be interrupted (e. g. for couplers).

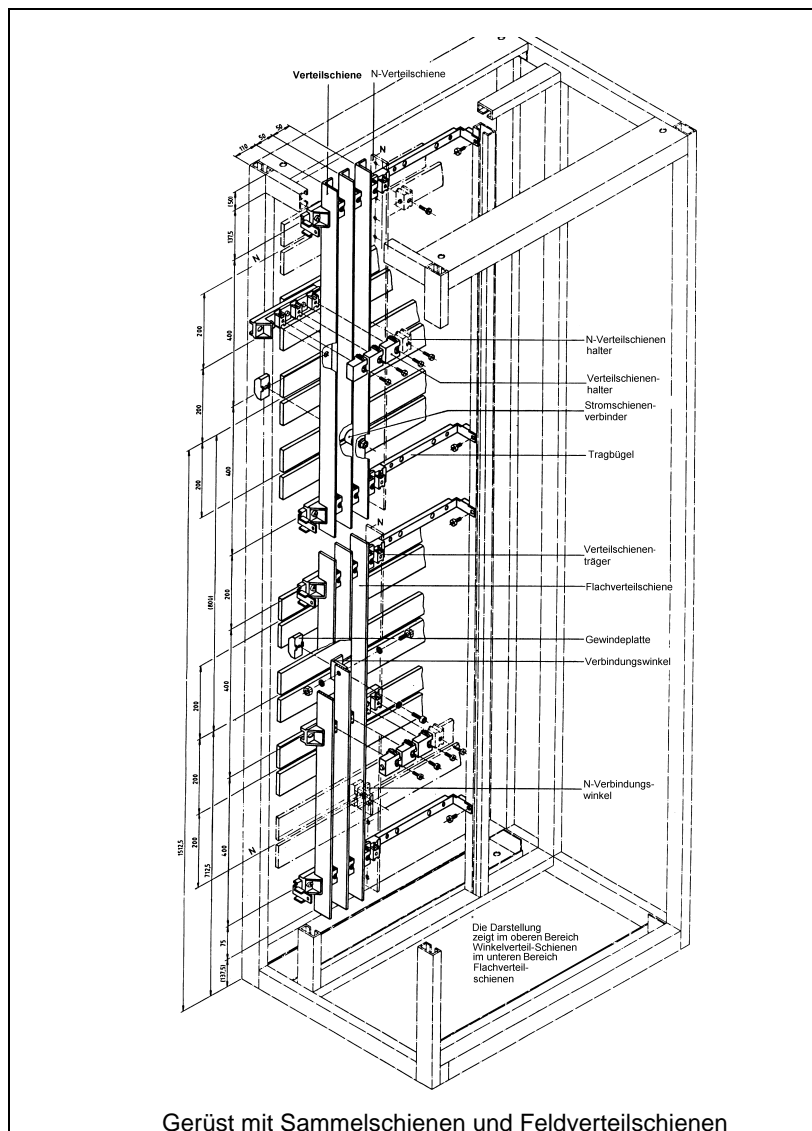

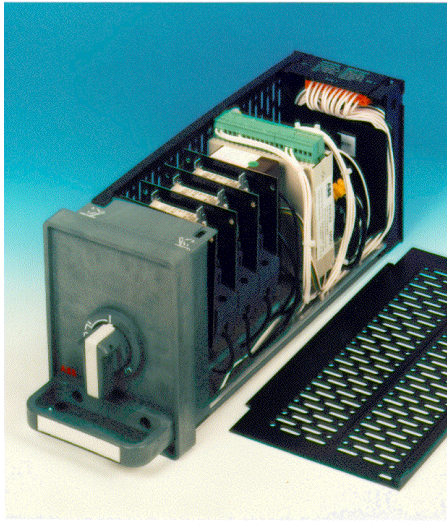

DE 961141

Withdrawable module size 8E/4 with INSUM®

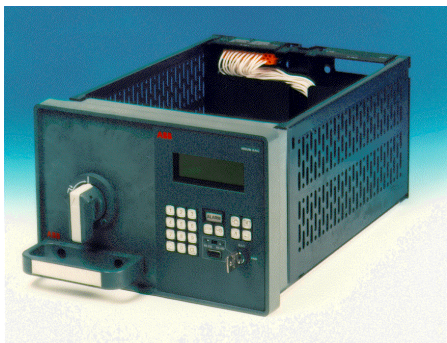

DE 961140

Withdrawable module size 8E/2 with Operating and annunciation module BAG

INSUM® in MNS - the intelligent solution for Motor Control Center

The INSUM® system integrates control, monitoring, measurement and annunciation functions for alternating current and three phase current motors. Furtheron, it records measurements and announces operating conditions of the respective motors. On top of that, air and moulded case circuit breakers can be actuated by INSUM®.

The function range of INSUM® can be easily adapted to different types of motors and the corresponding actuator unit circuit variants. For project specified requirements, and if necessary their modifications, only the parameters of the universal INSUM® measuring and control unit MSG need to be adjusted - instead of using different protecting, measuring and announcing devices.

INSUM® allows the connection of the motor control centre to higher-level control systems via serial bus. The adaptation to the respective hard- and software conditions is done by the INSUM® protocol converter (PK).

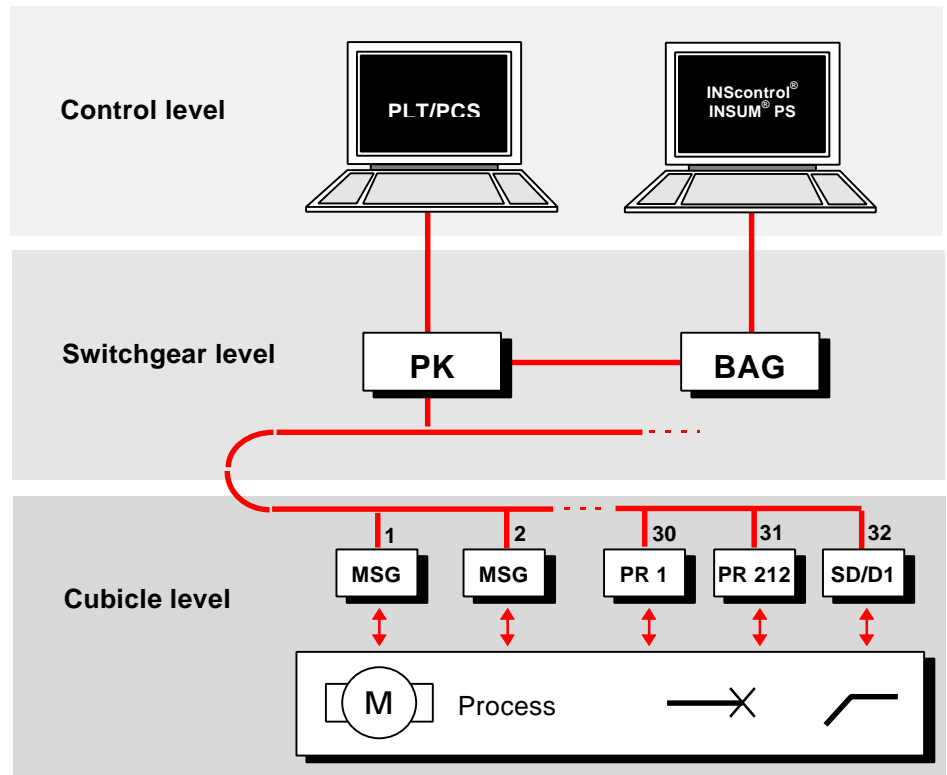

System structure INSUM®

The INSUM[®] system provides the following functions:

Protection functions

- Overload protection / automatic restart
- Underload indication
- No-load protection
- Stall protection
- Phase failure monitoring
- Restart blocking
- Safety interlocks
- Thermistor motor protection
- Supply failure monitoring / staggered start in case of restored supply
- Earth leakage protection
- Bus monitoring / Failsafe-function
- INSUM[®] version check

Operating functions

- Motor control via BAG, local control panel or control system
- Test function

Recording of measured and counted values

- Data acquisition
- Analog output (0-20 or 4-20 mA)
- Switching cycle counter
- Operating hour counter

Annunciation functions

- Status information
- Warning and fault messages

Communication

- Providing of all data for a higher-level control system via serial interface
- Parametering and event recording using PC-Software INSUM[®] PS

More detailed information's for operation are available in the brochure „Technical Information INSUM[®]“. This brochure is obtainable under number: „DIL 1063 96 D“.

Fixed-modules (motor starters up to 450 kW and feeders up to 800 A) are connected to the distribution bars by means of fixed bolt connections. The connections are realised by using power cables or fixed bars. The degree of protection is IP 20 against the distribution bars and IP 30 against the cable compartment.

Basic parts for fixed modules consist of assembly plate, side walls (left and right), bushing side walls for outgoing compartment bottom plate, which separates the modules from each other.

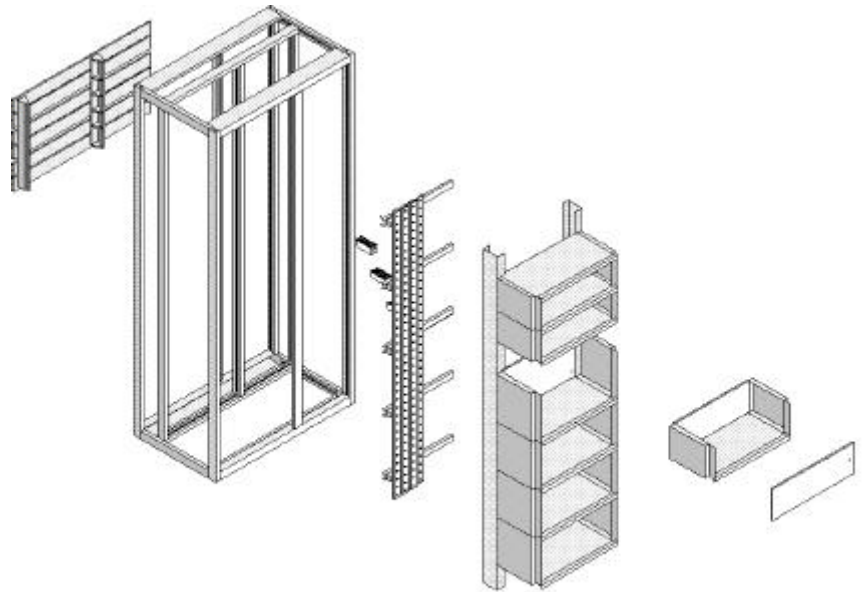

Energy distribution, fused 3- und 4-pole (OESA)

Rated current A		Module dimensions		
		Height E = 25 mm	Width B1 mm	Depth T1 mm
63 up to 160		8	600	400
250 up to 400		12, 16 ¹⁾	600	400
630 up to 800		24	600	400

¹⁾ Height of module for 4-pole construction

Energy distribution, fuseless 3- und 4-pole (ISOMAX S)

Rated current A	Rated short-circuit capacity kA	Module dimensions		
		Height E = 25 mm	Width B1 mm	Depth T1 mm
32 up to 250	35, 65	8, 12 ¹⁾	600	400
320 up to 400	35, 65	12	600	400
630 up to 800	35, 65	16	600	400

¹⁾ Height of module for 4-pole construction

Standard type program motor starter (with thermal relay)

Non-reversing motor starters

Motor powers with AC3 U = 400V, 500V, 690V up to ... kW			Module dimensions Height	Width	Depth
fused			Non-reversing E = 25 mm	B1 mm	T1 mm
22	30	22	8	600	400
30	37	55	16	600	400
110	160	160	20	600	400
250	250	250	72	600	400
fuseless					
7,5	7,5	7,5	8	600	400
30	30	160	12	600	400
75	75	-	16	600	400
110	110	515	20	600	400
160	200	-	24	600	400
250	315	355	72	600	400

Reversing motor starters

Motor powers with AC3 U = 400V, 500V, 690V up to ... kW			Module dimensions Height	Width	Depth
fused			Reversing E = 25 mm	B1 mm	T1 mm
11	15	11	8	600	400
22	30	30	12	600	400
30	37	55	16	600	400
90	110	110	24	600	400
110	160	160	28	600	400
250	315	250	72	600	400
fuseless					
7,5	7,5	7,5	8	600	400
-	30	-	12	600	400
30	-	-	16	600	400
55	45	30	20	600	400
75	75	-	24	600	400
110	110	160	28	600	400
160	200	250	32	600	400
250	315	355	72	600	400

Star-delta motor starters

Motor powers with AC3 U = 400V up to ... kW			Module dimensions Height	Width	Depth
fused			Star-delta E = 25 mm	B1 mm	T1 mm
55			12	600	400
110			24	600	400
132			32	600	400
250			72	600	400
fuseless					
18,5			8	600	400
55			12	600	400
-			16	600	400
-			20	600	400
110			24	600	400
160			28	600	400
250			72	600	400

For details, see the Technical Data Sheets

Strip-type energy modules

The SR series comprises strip-type equipment for load-breaking and fuse protection to be installed in MNS switchgear systems. The completely assembled unit is installed horizontally in the switchgear cubicle with an equipment compartment 600 mm wide and 200 or 400 mm deep. The vertical space requirements is 2E, 4E or 8E (1E = 25 mm), depending on the equipment size.

The unit fronts are equipped with plastic covers or doors hinged on the left-hand side with degree of protection IP 41. The outgoing cable connection is made with brackets or cable terminals.

The switch-disconnector is equipped with a spring-assisted mechanism, and the switching speed does not depend on the operation speed of the switch disconnector handle at the front. The switching state can be observed from outside through a transparent front cover and by the position of the handle. An interlocking device between the switch-disconnector and the front cover prevents the cover from being opened when the switch is closed.

With switch type SR-E, the load-breaking element is located in the fuse access section, with switch type SR-M it is found on both sides of the fuses so that the fuses can only be replaced when the switch is open.

The following additional components may be fitted:

- 1 current transformer (integrated into strip)
- 3 current transformer (only with 400 mm equipment compartment depth)
- 1 ammeter 48 x 48 (integrated into strip)
- plug-in connections for fuse monitoring
- plug-in connections for signalling the switch position

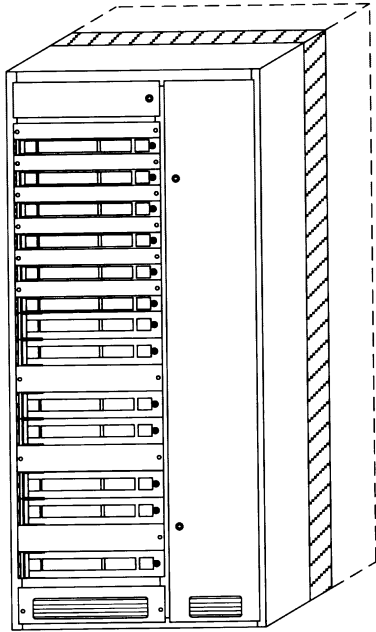

Switchgear cubicle for strip-type outgoing energy modules

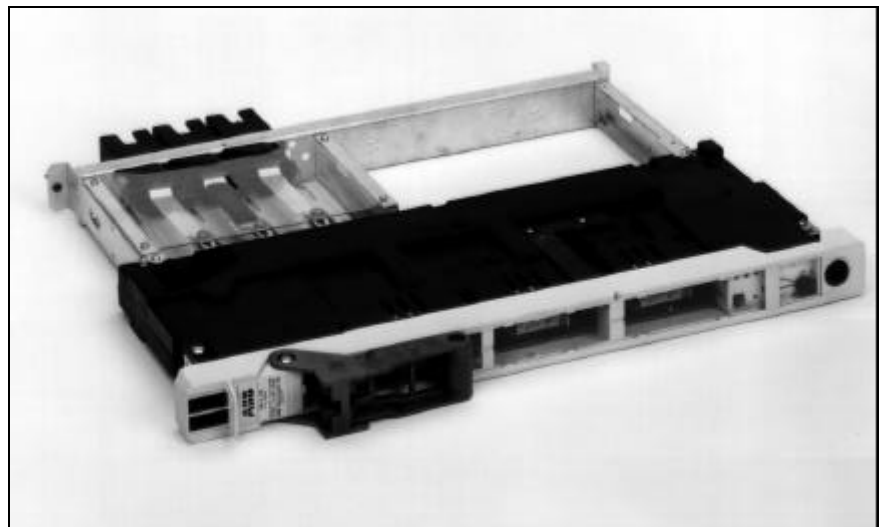

Fused load-break switches SR00

DE 960598/1

Plug-In modules

The basic elements are supporting plates and mounting rails made of an aluminium alloy. The vertical rail serves as a fastening element for securing the module to the frame. By combining supporting plates and mounting rails, modules of any desired height can be realized.

The Plug-In-mounted modules can be combined with front modules for indicating, measuring, signalling and operating equipment.

Modular construction offers major advantages for the user:

- Compact design
- Easy replacement of complete functional units by means of plug-in connection at the primary side
- Easy, time-saving maintenance and testing
- Adaptability to changed service conditions
- Large cable compartments for easy connection of cables
- Automatic contacting (without screws) by means of plug-in contact units up to a rated current of 630 A
- Suitable for 690 V AC and 750 V DC
- Factory-assembled supply to IEC 439-1 and VDE 0660 part 500, type tested

A standard range of equipment is available (MCC) (see pages 4.2/4 - 4.2/10). With standardized components and assemblies, Plug-In-mounted units (modules) can be produced in accordance with the customer's specification.

The modules are installed horizontally at the module frame in the equipment compartment of an MNS cubicle 600 mm wide and are connected to the distribution bars with the help of contact units (plug-in connection).

Outgoing cables and feeders are connected to terminals. Wiring ducts can be mounted between the mounting rails.

The module height depends on the equipment and the rated power.

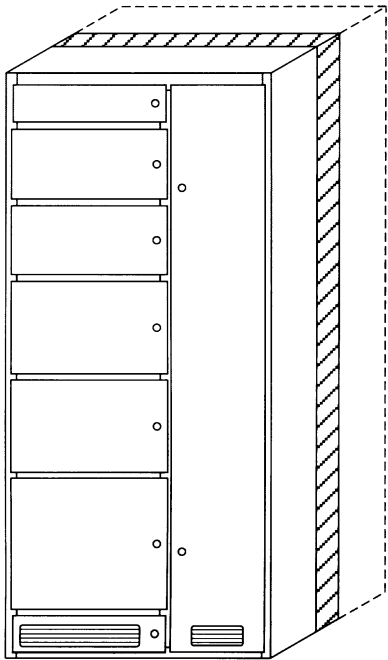

Switchgear cubicle for fixed modules

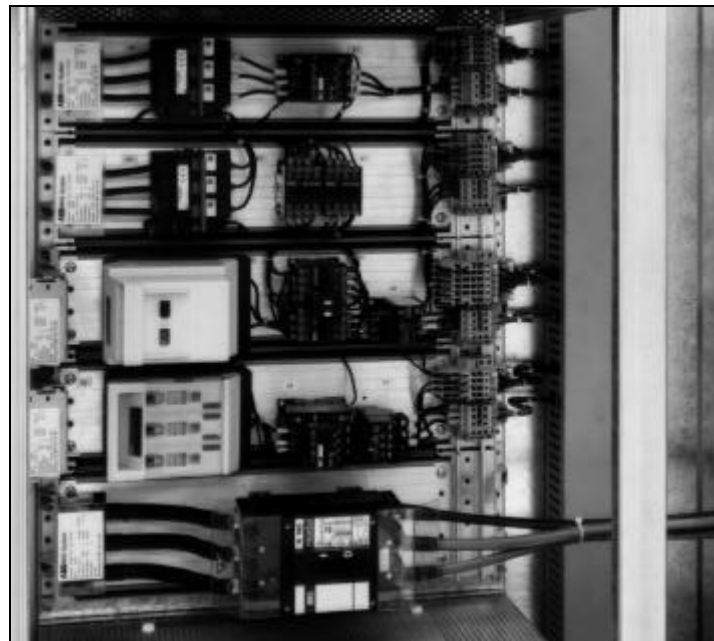

Plu-In modules in the equipment compartment

When modules are replaced, retrofitted, or a module extension is carried out (e. g. subsequent installation in spare modules), the cubicle must be disconnected from the mains.

The basic design of the standard fixed-mounted modules comprises the equipment carrier, the contact units to be connected to distribution bars, and terminals for incoming cables.

Depending on the application, the components are installed in various combinations:

- Switch-disconnectors (with and without fuse monitoring)
- Energy distribution, fuse based (SLP)
- Load break switch (OETL)
- Moulded case circuit breaker (MCCB)
- Fuse based motor starter, with thermo relay or INSUM[®]
- Fuseless motor starter, with thermo relay or INSUM[®]
- Reactive power compensation

Additionally, standard version of auxiliary circuits are available.

Removable-Modules

The removable modules have plug-in connections to the incoming supply from the distribution bar system, whereas the outgoing cables are connected permanently direct to the apparatus terminals. The auxiliary circuits are connected via multi-pole plug-in contact units.

The main switch is operated by the operating handle on the module door which is also used for the mechanical interlocking.

DE 910069/8

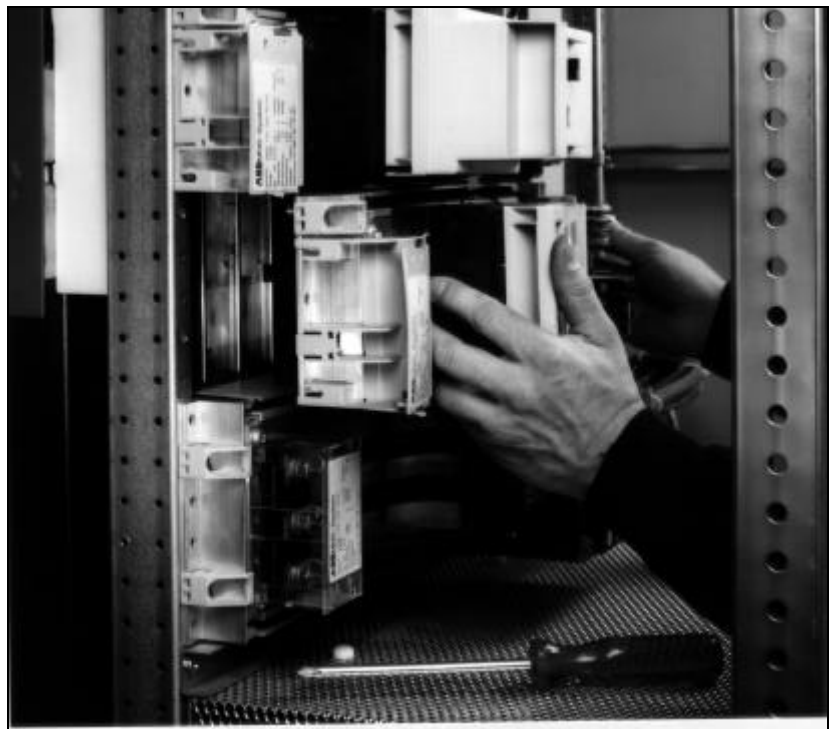

Replacement of modules

Standard modules for energy distribution

Strip-Type fuse switch disconnecter (SR)

Type		SR-B	SR-E	SR-L	SR-M	SR-S	SR-U	Overall height/mm
Rated voltage	V	690	690	500	690	690	500	
Rated current	A	160	160 ¹⁾	160	160	-	160	50, 100 ¹⁾
		250	250 ¹⁾	-	250	-	250	100, 150 ¹⁾
		400	400 ¹⁾	-	400	400	400	200, 300 ¹⁾
		630	630 ¹⁾	-	630	630	630	200, 300 ¹⁾
Short-circuit making current	kA	50	50	50	50	50	-	
Dyn. short-circuit strength	kA	-	100	100	100	100	100	
Utilization category		AC22	AC21	AC21	AC23	AC23	AC20	

¹⁾ SR-E-are also available at this overall height/mm

¹⁾ Module height for 4-pole type

Fuse based (SLP)

Rated current A	Rated breaking capacity Utilization category AC22 bei 690 V~ A	Module dimensions		
		Height E = 25 mm	Width B1 mm	Depth T1 mm
125	800	7;9	600	400

Switch disconnecter (OETL)

Rated current A	Making capacity kA	Rated operating current Utilization category AC21 bei 400 - 690 V~ A	Module dimensions		
			Height E = 25 mm	Width B1 mm	Depth T1 mm
200	35	200	11, 13 ¹⁾	600	400
250	35	250	11, 13 ¹⁾	600	400
315	35	315	11, 13 ¹⁾	600	400
400	65	500	15, 17 ¹⁾	600	400
630	80	630	17, 19 ¹⁾	600	400

¹⁾ Module height for 4-pole type

Moulded case circuit breaker

Switch Type	Rated current A	Rated breaking capacity bei 400 V~		Module dimensions		
		kA	bei cos φ =	Height E = 25 mm	Width B1 mm	Depth T1 mm
Motor protecting switch	11	10	-	5; 9	600	400
Current limiter	32	50	0,5	5; 9	600	400
	63	50	0,5	5; 9	600	400
	125	170	0,25	9; 11	600	400
	200	200	0,2	9; 11	600	400
	320	200	0,2	9; 13	600	400
	500	200	0,2	13	600	400
	630	200	0,2	13	600	400
Zero-point circuit breaker	125	65 / 85	0,3; 0,25	7; 11	600	400
	160	35 - 100	0,25	9; 11	600	400
	250	35 - 100	0,25	9; 11	600	400
	400	35 - 100	0,25	15	600	400
	630	65 - 100	0,25	15	600	400

For details, see the Technical Data Sheets

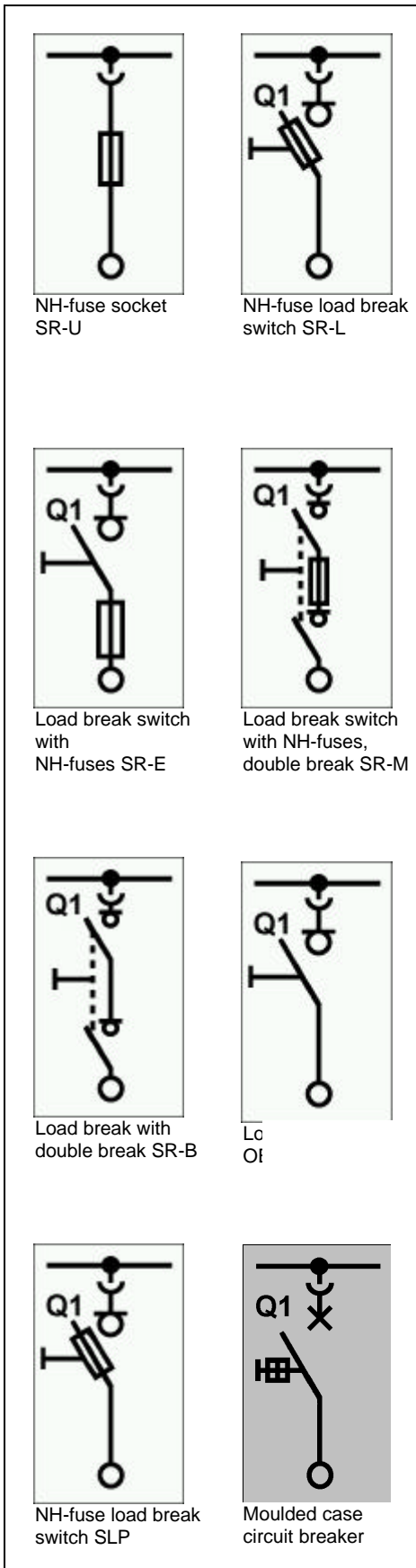

Standard type program motor starter (fused with thermo relay)

Non-reversing and reversing

Motor power with AC3 kW	Module dimensions Height		Width B1 mm	Depth T1 mm
	Non-reversing	Reversing		
	E = 25 mm			
5,5	5; 9	5; 9	600	400
7,5	5; 9	5; 9	600	400
15	5; 9	7; 11	600	400
22	7; 11	9; 13	600	400
30	7; 11	9; 13	600	400
37	7; 11	9; 13	600	400
45	11	11	600	400
55	17	17	600	400
75	17	17	600	400
110	23	23	600	400
160	29	37	600	400
200	31	39	600	400
250	31	-	600	400

Heavy-duty motor starters

Motor powers bei AC3 kW	Module dimensions Height		Width B1 mm	Depth T1 mm
	Heavy-duty			
	E = 25 mm			
4	7; 11		600	400
5,5	7; 11		600	400
7,5	7; 11		600	400
15	9; 13		600	400
22	9; 13		600	400
30	9; 13		600	400
37	11		600	400
45	11		600	400
55	17		600	400
75	23		600	400
110	29		600	400
160	31		600	400
200	31		600	400

Star-delta motor starters

Motor powers bei AC3 kW	Module dimensions Height		Width B1 mm	Depth T1 mm
	Star-delta			
	E = 25 mm			
7,5	7		600	400
12,5	7		600	400
22	9		600	400
30	9		600	400
45	11		600	400
55	17		600	400
75	19		600	400
90	21		600	400
129	27		600	400
184	27		600	400
220	37		600	400

For details, see the Technical Data Sheets

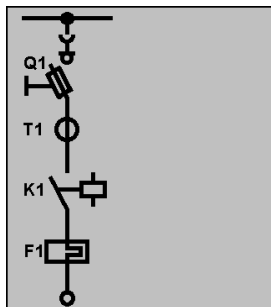

Non-reversing motor starter

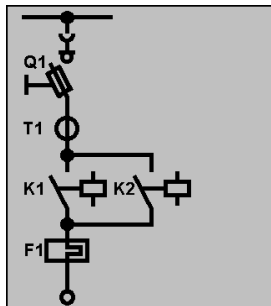

Reversing motor starter

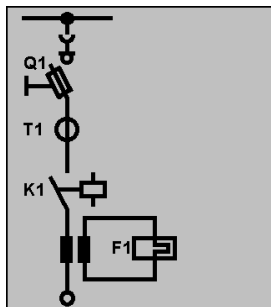

Heavy duty motor starter

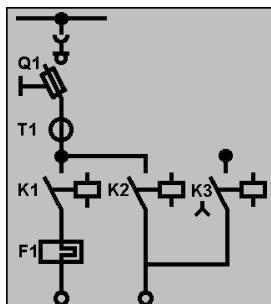

Star-delta motor starter

Standard type program motor starter (fuseless)

Non-reversing and reversing

Motor powers with AC3 kW	Module dimensions			
	Height Non-reversing E = 25 mm	Reversing E = 25 mm	Width B1 mm	Depth T1 mm
1,5 ¹⁾	5; 9	5; 9	600	400
2,2 ¹⁾	5; 9	5; 9	600	400
5,5 ¹⁾	5; 9	5; 9	600	400
7,5 ¹⁾	5; 9	9	600	400
15 ¹⁾	7; 9	9	600	400
22 ¹⁾	7; 9	9	600	400
30 ¹⁾	9	9	600	400
37	13	13	600	400
45	17	17	600	400
55	17	17	600	400
75	17	17	600	400
110	19	27	600	400
160	31	39	600	400
200	31	39	600	400
250	31	-	600	400

¹⁾ up to 30kW also with thermo release in circuit breaker

Heavy-duty motor starters

Motor powers with AC3 kW	Module dimensions		
	Height Heavy-duty E = 25 mm	Width B1 mm	Depth T1 mm
1,5	9	600	400
2,2	9	600	400
5,5	9	600	400
7,5	9	600	400
15	9; 11	600	400
22	9	600	400
30	9	600	400
37	13	600	400
45	17	600	400
55	17	600	400
75	23	600	400
110	27	600	400
160	31	600	400
200	31	600	400
250	31	600	400

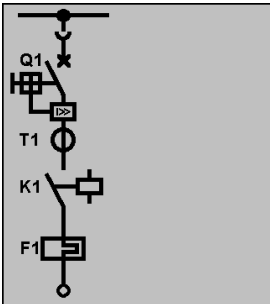

Non-reversing motor starter

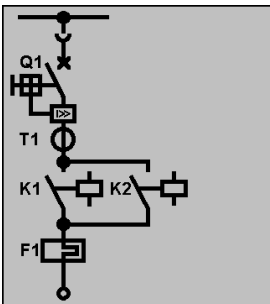

Reversing motor starter

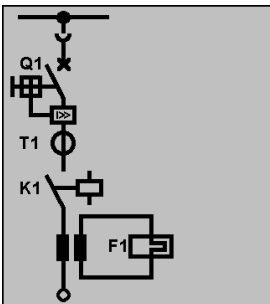

Heavy-duty motor starter

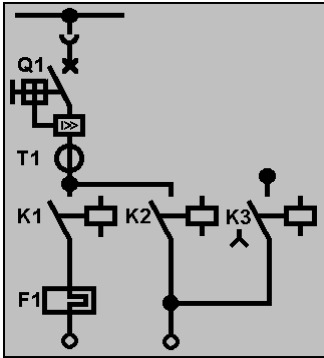

Star-delta motor starter

Star-delta motor starters

Motor powers with AC3	Module dimensions		
	Height E = 25 mm	Width B1 mm	Depth T1 mm
5,5	9	600	400
7,5	9	600	400
12,5	9	600	400
15	9	600	400
22	9	600	400
30	9; 11	600	400
45	13	600	400
55	17	600	400
75	17	600	400
90	17	600	400
129	17	600	400
184	31	600	400
220	39	600	400

For details, see the Technical Data Sheets

Standard type program motor starter (fused, with INSUM®)

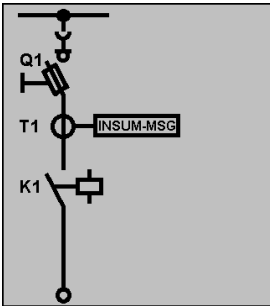

Non-reversing motor starter with INSUM®, also for heavy-duty motor starters

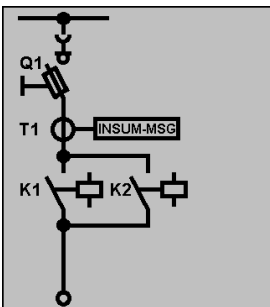

Reversing motor starter with INSUM®

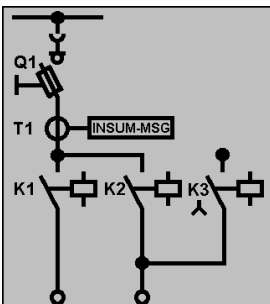

Star-delta motor starter with INSUM®

Non-reversing and reversing

Motor powers with AC3 kW	Module dimensions		Width B1 mm	Depth T1 mm
	Heigh Non-reversing E = 25 mm	Reversing E = 25 mm		
1,5	7; 9	7; 9	600	400
5,5	7; 9	7; 9	600	400
7,5	7; 9	7; 9	600	400
15	9	9	600	400
22	9	9	600	400
30	9	9	600	400
37	9	11	600	400
45	9	13	600	400
55	17	19	600	400
75	17	19	600	400
110	23	23	600	400
160	29	37	600	400
200	31	39	600	400
250	31	-	600	400

Heavy-duty motor starters

Motor powers with AC3 kW	Module dimensions		Width B1 mm	Depth T1 mm
	Heigh E = 25 mm			
1,5	7; 9		600	400
4	7; 9		600	400
5,5	7; 9		600	400
7,5	7; 9		600	400
15	9		600	400
22	9		600	400
30	9		600	400
37	9		600	400
45	11		600	400
55	17		600	400
75	17		600	400
110	29		600	400
160	31		600	400
200	31		600	400

Star-delta motor starters

Motor powers with AC3 kW	Module dimensions		Width B1 mm	Depth T1 mm
	Heigh E = 25 mm			
7,5	9		600	400
12,5	9		600	400
22	11		600	400
30	11		600	400
45	11		600	400
55	19		600	400
75	19		600	400
90	19		600	400
129	27		600	400
184	29		600	400
220	37		600	400

For details, see the Technical Data Sheets

Standard type program motor starter (fuseless, with INSUM®)

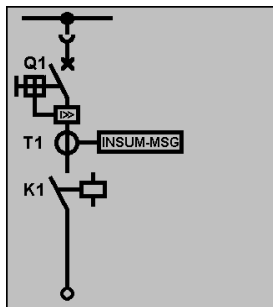

Non-reversing motor starter with INSUM®, also for heavy-duty motor starters

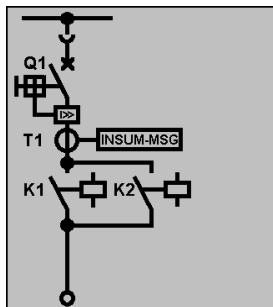

Reversing motor starter with INSUM®

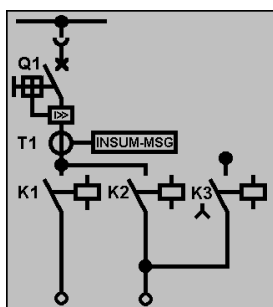

Star-delta motor starter with INSUM®

Non-reversing and reversing

Motor powers with AC3 kW	Module dimensions			
	Height		Width B1 mm	Depth T1 mm
	Non-reversing	Reversing		
	E = 25 mm			
1,5	7; 9	7; 9	600	400
2,2	7; 9	7; 9	600	400
5,5	7; 9	7; 9	600	400
7,5	7; 9	7; 9	600	400
15	9; 11	9; 11	600	400
22	9; 11	9; 11	600	400
30	9	9	600	400
37	13	13	600	400
45	13	17	600	400
55	17	17	600	400
75	17	17	600	400
110	19	19	600	400
160	31	39	600	400
200	31	39	600	400
250	31	-	600	400

Heavy-duty motor starters

Motor powers with AC3 kW	Module dimensions		
	Height		Depth T1 mm
	E = 25 mm		
	mm		
1,5	7	600	400
2,2	7	600	400
5,5	7	600	400
7,5	7; 9	600	400
15	9	600	400
22	9	600	400
30	9	600	400
37	13	600	400
45	13	600	400
55	17	600	400
75	17	600	400
110	27	600	400
160	31	600	400
200	31	600	400
250	31	600	400

Star-delta motor starters

Motor powers with AC3 kW	Module dimensions		
	Height		Depth T1 mm
	E = 25 mm		
	mm		
5,5	9	600	400
7,5	9	600	400
12,5	9	600	400
15	11	600	400
22	11	600	400
30	11	600	400
45	13	600	400
55	17	600	400
75	17	600	400
90	17	600	400
129	27	600	400
184	27	600	400
220	39	600	400

Standard type program energy distribution (R-Modules)

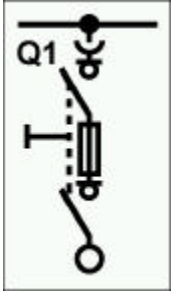

Load break switch with NH-fuses OESA

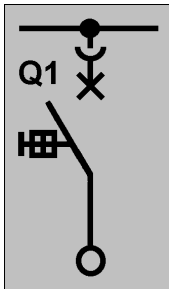

Moduled case circuit breaker ISOMAX S

Energy distribution, fused 3- und 4-pole (OESA)

Rated current A		Module dimensions		
		Height E = 25 mm	Width B1 mm	Depth T1 mm
Feeder				
160		8	600	400
250 bis 400		8, 12 ¹⁾	600	400
630 bis 800		12, 16 ¹⁾	600	400
Coupling				
250 bis 400		8, 12 ¹⁾	600	400
630 bis 800		16, 20 ¹⁾	600	400

¹⁾ Module height for 4-pole type

Energy distribution, fuseless 3- und 4-pole (ISOMAX S)

Rated current A	Rated breaking capacity kA	Module dimensions		
		Height E = 25 mm	Width B1 mm	Depth T1 mm
32 bis 250	35, 65	8	600	400
320 bis 400	35, 65	8, 12 ¹⁾	600	400
500 bis 800	35, 65	12, 16 ¹⁾	600	400

¹⁾ Module height for 4-pole type

Einzelheiten sind den Technischen Datenblättern zu entnehmen

Reactive power compensation

The reactive power compensation for the MNS[®]-system is designed in removable modules. In the standard there are two series of modules for 400 V, 500 V and 690 V available. Fuse switches or -bases, contactors, control terminals and reactive power controllers, if necessary, are installed at the front side.

The standard reactive power controllers type RPR12 have 12 switching steps. They are installed in a separate unit of 8E height. The measuring and control voltages are protected with miniature circuit-breakers MS 325-1.6 A (unlimited breaking capacity, no back-up fuse required). For nominal voltages of 500 or 690 V, a control voltage transformer is integrated into the controller module.

Modules with dry-type capacitors in MNS[®]-removable-technique are 14E high and designed for an equipment compartment of 600 mm width and 400 mm depth. They will be connected to the distribution bars via plug-in contacts and are available without reactor, with reactor (5,67%, 7%, 12,5%, 14% and 15%) and as combined filters (5/12,5% and 5,67/12,5%) with different unit-powers.

MNS[®]-removable-modules with oil impregnated capacitors are designed for an equipment compartment of 600 x 400 mm and connection to the distribution bars via plug-in contacts. In a height of 16E (1E = 25 mm), they are available without reactor, with reactor (7%, 12,5%) and as combined filters (5/12,5% and 5,67/12,5%).

A controller can be integrated in modules of this type with up to 4 switching steps, but only without control voltage transformer.

On request special technical solutions are also available, e.g. other voltages, different reactor rates, modules in partial reactor design or audio frequency rejector circuits.

An MNS[®] compensation system (size per cubicle H x W x D = 2275 x 600 x 600 mm) is usually delivered with lifting lugs and a roof structure with an elevated hood, direct connection of cables to the distribution bars are provided, feeding via busbars is also possible. Optionally a multi-functional separator is available. The system is designed for protection degree IP 20 or IP 30 and a mean ambient temperature

of ≤ 35 °C over 24 h. If higher degrees of protection are required, or if the ambient temperature is higher, the compensation power in the cubicle must be reduced accordingly, or forced ventilation must be provided.

The front door is equipped with 4 ventilation louvers, in order to avoid heat accumulation, there must be a 30 cm clearance above the cubicle. In order to ensure sufficient air circulation in the event of rear wall ventilation, the distance between the cubicle and the wall should be at least 8 cm. If the compensation power is higher than 200 kvar per cubicle for systems in reactor design (400 kvar without reactor, single-step modules with dry-type capacitors and reactor 250 kvar), forced ventilation is provided by means of a temperature controlled fan in the front-door.

Operation with permanently higher voltages than the nominal mains voltage or with considerable harmonic distortion will cause a significant increase in the power loss so that in this case it is also advisable to reduce the compensation power in each cubicle in order to increase the useful life of the system.

Detailed technical data and engineering hints are available in the „Technical Information Reactive power compensation“ (ID-no. 1TGR 400 001 E).

Range of standard types for reactive power compensation modules

Modules with dry-type capacitors

Nominal net voltage	p-value	Power per module
400 V	0%	4 x 10 kVAr, 4 x 12,5 kVAr, 3 x 20 kVAr, 3 x 25 kVAr
	5,67%, 7%	2 x 10 kVAr, 2 x 12,5 kVAr, 2 x 20 kVAr, 2 x 25 kVAr, 1 x 40 kVAr, 1 x 50 kVAr
	12,5%, 14%, 15%	2 x 10 kVAr, 2 x 20 kVAr, 1 x 40 kVAr
	5/12,5%, 5,67/12,5%	1 x 20 kVAr, 1 x 40 kVAr
500 V	0%	4 x 10 kVAr, 3 x 20 kVAr
	5,67%, 7%	2 x 10 kVAr, 2 x 20 kVAr, 1 x 40 kVAr
	12,5%, 14%, 15%	2 x 10 kVAr, 2 x 20 kVAr, 1 x 40 kVAr
	5/12,5%, 5,67/12,5%	1 x 20 kVAr, 1 x 40 kVAr
690 V	0%	4 x 10 kVAr, 4 x 12,5 kVAr, 3 x 20 kVAr, 3 x 25 kVAr
	5,67%, 7%	2 x 10 kVAr, 2 x 12,5 kVAr, 2 x 20 kVAr, 2 x 25 kVAr, 1 x 40 kVAr, 1 x 50 kVAr
	12,5%, 14%, 15%	2 x 10 kVAr, 2 x 20 kVAr, 1 x 40 kVAr
	5/12,5%, 5,67/12,5%	1 x 20 kVAr, 1 x 40 kVAr

Subject to technical alterations

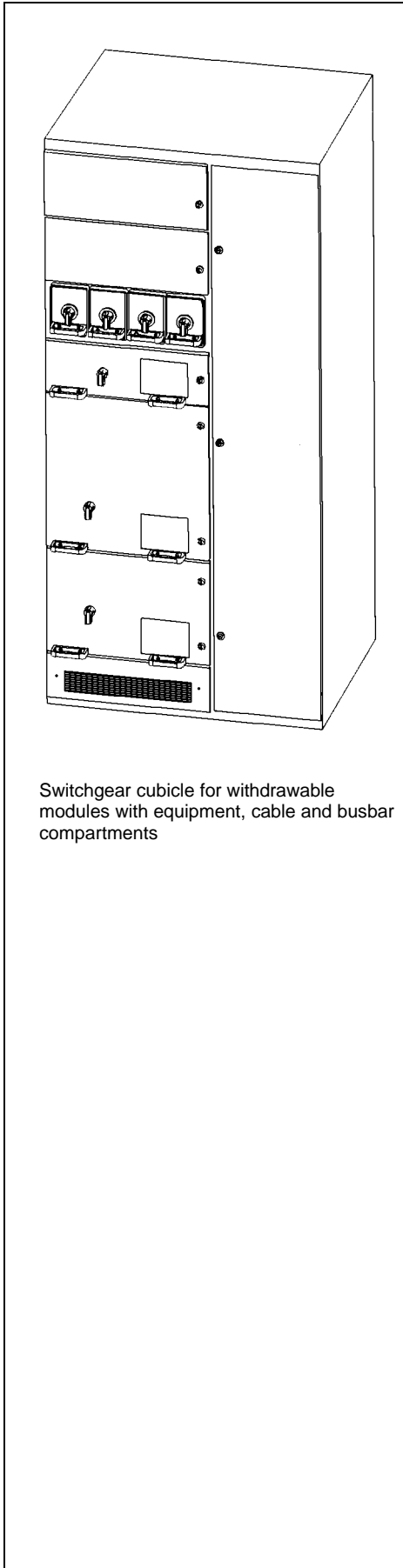

Switchgear cubicle for withdrawable modules with equipment, cable and busbar compartments

Cubicle structure

In the MNS system, components belonging to one functional group are assembled to form a single mechanical and electrical module. Power and control modules are available as withdrawable types.

In the MNS system, components belonging to one functional group are assembled to form a single mechanical and electrical module. Power and control modules are available as withdrawable types.

In the MNS system, components belonging to one functional group are assembled to form a single mechanical and electrical module. Power and control modules are available as withdrawable types.

For size 8E/4 four modules and for size 8E/2 two modules are arranged horizontally at a width of 600 mm. The height of these modules is 8E = 200 mm.

Withdrawable modules size 4E, 8E, 12E, 16E, 20E and 24E require the entire equipment compartment width of 600 mm per module. The size designation also specifies the vertical space requirement in E.

The withdrawable modules can be withdrawn when connected to mains. Type tests have proven 100 withdrawal/insertion cycles. Conversion of the withdrawable module compartments is possible without any danger without disconnecting the neighbouring modules.



Withdrawable module compartments size 8E/4 and 8E/2

Multi-function separator

For switchgear cubicles in withdrawable design, or in combines fixed-mounted and withdrawable design, one-pole distribution bars (angular section 50 x 30 x 5 [mm]) are embedded into the multi-function separator made of insulating material and protected by distribution bar covers. Shock hazard protection (IP 20) with respect to the entire busbar system is thus ensured without a shutter. As with open installation, a max. of two busbar systems can be installed (also in sections).

The multi-function separator is resistant to accidental arcs and thus constitutes a partition between the equipment compartment and the busbar compartment.

Compartments size 8E/4 and 8E/2

Compartments size 8E/4 and 8E/2 consist of a compartment bottom plate, a module condaptor, guide rails and front posts. The module condaptor provides the connection of the power and control circuit with the distribution bar, the module and the cable compartment.

The withdrawable module condaptor is designed for a current up to 125 A and can hold 2 modules size 8E/2 up to 63 A or 4 modules size 8E/4 up to 45 A. It comprises a 20-pole control connector for each module size 8E/4 and one or two 20-pole control connectors for each module size 8E/2.

The connections between the incoming and outgoing side are arranged inside the withdrawable module condaptor and are protected against accidental arcs.

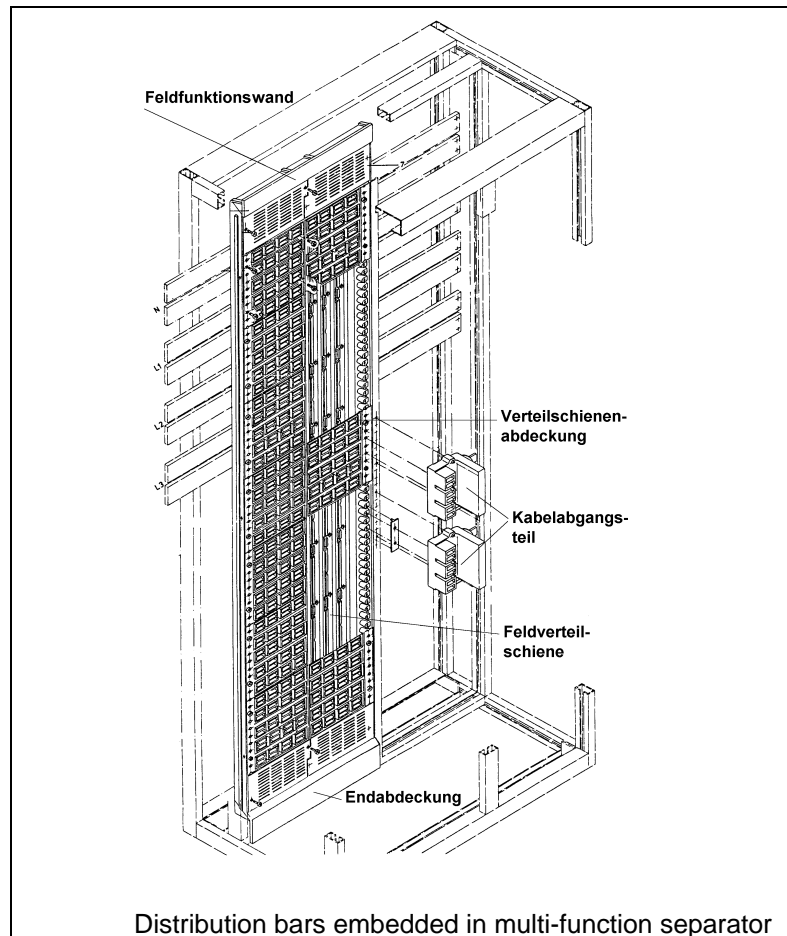

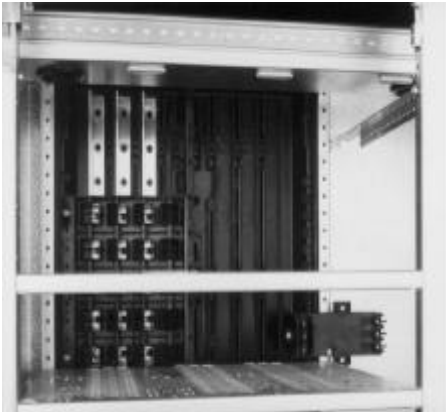

DE 970258/11

Compartments size 8 E and 4 E

Compartments size 4E...24 E

Compartments size 8E ... 24E consist of a compartment bottom plate, guide rails and a sheet metal side wall with the outgoing control connector. Withdrawable module feeder connection to the distribution bars in the multi-function separator is made by means of one-pole segregated contact units. Outgoing power cables are connected via cable connectors (main circuit), control cable connections are established via 16 or 32-pole by the 4E-Module for 16 or 20-pole control connectors (auxiliary circuits). The power cable connectors are fastened to the multi-function separator.

Cable and wiring connections

At one side of the withdrawable modules, in the cable compartment, there are cable connection elements and terminal blocks for connecting outgoing cables and wires and interconnecting the modules.

The incoming and outgoing cables and wires are mounted to cable mounting rails located at the right-hand side of the cable compartment.

The power terminals are located in the rear area, the control terminals are arranged in front of them, turned by 45°.

The control terminals provide for cable connection in screw-on or plug-in technique or with the Termipoint method. The power terminals on the withdrawable module condaptors up to 63A are additionally equipped with PE terminals.

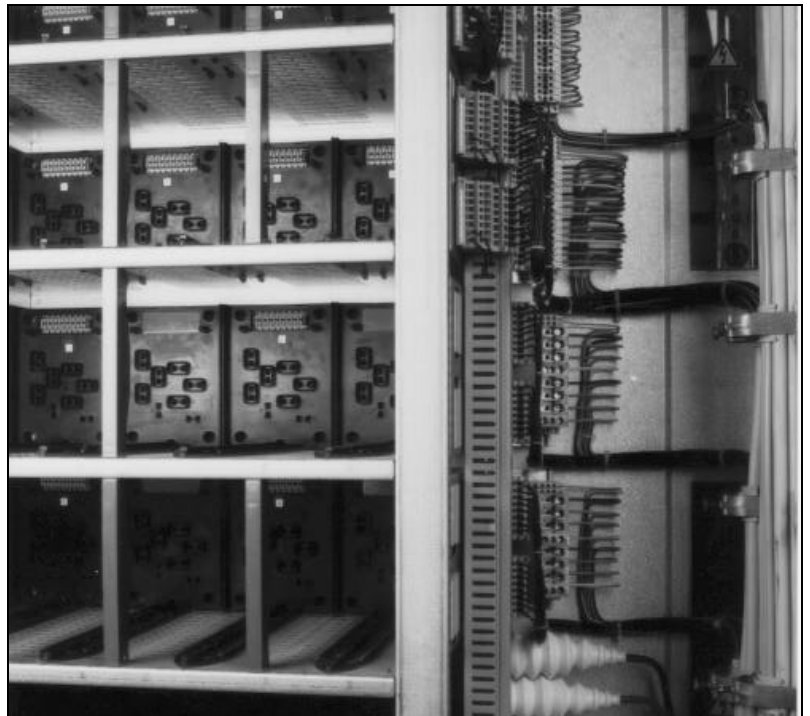

DE 960596/7

Cable and wiring connections in a switchgear cubicle with withdrawable modules

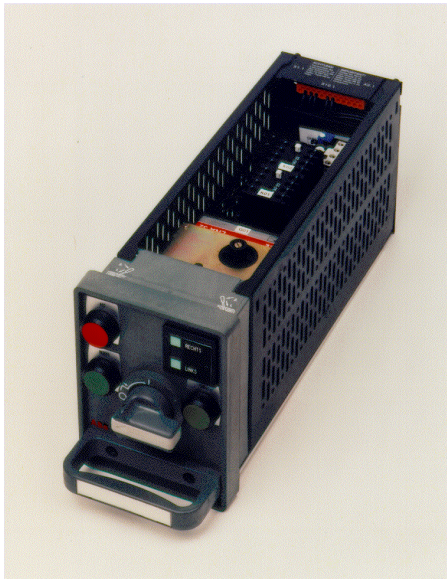

DE 970257

Withdrawable module size 8E/4

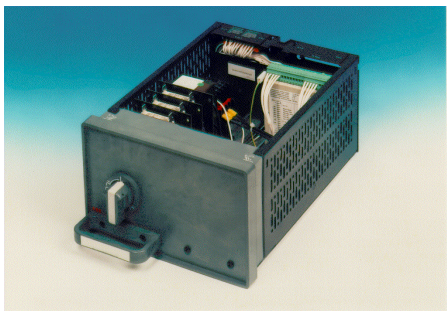

DE 961137

Withdrawable module size 8E/2

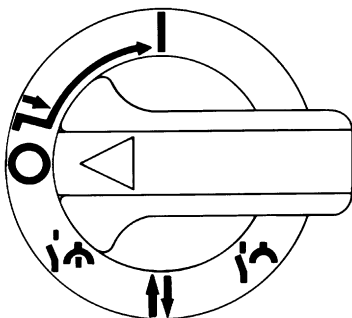

switch handle

Withdrawable modules

Standardized withdrawable modules:

- Energy distribution by means of switch disconnecter or moulded-case circuit-breaker
- Motor starter with fuses
- Motor starter without fuses
- Motor starter with INSUM® and fuses
- Motor starter with INSUM® without fuses

Available sizes: 8E/4, 8E/2, 4E, 8E, 12E, 16E, 20E und 24E (1 E = 25 mm)

Withdrawable module size 8E/4 and 8E/2

Withdrawable modules size 8E/4 and 8E/2 consist of the instrument panel and side panels made of insulating material, the rear wall with integrated cable connections, and a 20-pole control connector as well as one or two profile sections for mounting snap-mounted components. If required, the withdrawable module size 8E/2 can be equipped with two 20-pole control connectors.

The instrument panel has preformed knockouts for mounting measuring, operating and indicating instruments.

The main switchgear (normally a fused motor switch or circuit-breaker) is operated by means of the operating handle located at the instrument panel, which is also used for the electrical as well as the mechanical interlocking function. A micro-switch with 1 make and 1 break contacts is provided for electrical interlocking.

Description of the operating handle positions

	Position of switch	Position of Module	Main- and Control-circuits	Degree of Protection
	ON	in cubicle	All main- und control-circuits are connected	Accordance of the switch-gear (minimum IP 20)
	OFF Can be locked with 3 padlocks	in cubicle	All main- und control-circuits are disconnected	Accordance of the switch-gear (minimum IP 20)
	TEST Can be locked with 3 padlocks	in cubicle	All main-circuits are disconnected, the control-circuits are connected	Accordance of the switch-gear (minimum IP 20)
	MOVE Position	in cubicle - Isolated Position - not in cubicle	All main- und control-circuits are disconnected	The degree of Protection IP 20 is provided from the „in cubicle“ to the the „ISOLATED Position“
	ISOLATED Pos. Can be locked with 3 padlocks	The module is 30 mm drawn out of the cubicle	All main- und control-circuits are disconnected and the isolated requirements are fulfilled	The degree of Protection IP 20 is fulfilled



Module size 4E

DE 961142



Module size 8E

DE 951000

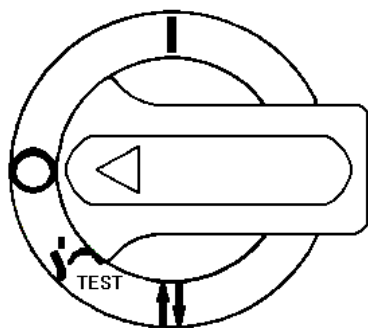

Switch

Withdrawable modules size 4E, 8E, 12E, 16E, 20E and 24E

Withdrawable modules size 4E up to size 24E consist of an instrument panel and a rear wall made of insulating material, and a front cover and side panels made of sheet steel, as well as mounting channels.

The hinged front cover offers the advantage of easy accessibility of the built-in components (e. g. for replacing fuses) from the front side without withdrawing the module. Opening the front cover in operating or test, is possible only with a tool (screwdriver, doublebit lock), in isolating position it is possible by doublebit lock.

The front cover is provided with a cut-out for an instrument panel. This panel remains in position when the front cover is opened. It is designed with preformed knockouts for mounting measuring, operating and indicating instruments and carries a switch handle by which the electrical (micro-switch with 1 NO and 1 NC contacts) and mechanical interlocks can be operated.

Description of the operating handle positions

	Position of switch	Position of Module	Main- and Control-circuits	Degree of Protection
	ON	in cubicle	All main- und control-circuits are connected	Accordance of the switch-gear (minimum IP 20)
	OFF Can be locked with 3 padlocks	in cubicle	All main- und control-circuits are disconnected	Accordance of the switch-gear (minimum IP 20)
	TEST Can be locked with 3 padlocks	in cubicle	All main-circuits are disconnected, the control-circuits are connected	Accordance of the switch-gear (minimum IP 20)
	MOVE Position	in cubicle - Isolated Position - not in cubicle	All main- und control-circuits are disconnected	The degree of Protection IP 20 is provided from the „in cubicle“ to the the „ISOLATED Position“
	ISOLATED Pos. Can be locked with 3 padlocks	The module is 30 mm drawn out of the cubicle	All main- und control-circuits are disconnected and the isolated requirements are fulfilled	The degree of Protection IP 20 is fulfilled

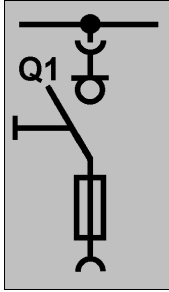

Fuse switch disconnector

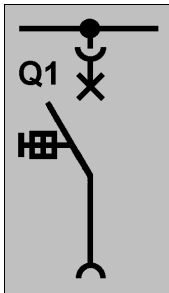

Moduled case circuit breaker

Standard modules for energy distribution

Fuse switch disconnector (OESA), 3-pole

Rated current A	Rated short-circuit breaking capacity at 690 V~, eff. kA	Module size E = 25 mm	Equipment compartment	
			Width B1 mm	Depth T1 mm
40	50	8E/4	(600)	400
63	50	8E/2	(600)	400
63	50	4E	600	400
160	50	8E	600	400
400	50	12E	600	400
400	50	16E	600	400
800	50	20E	600	400

Fuse switch disconnector (OESA), 4-pole

Rated current A	Rated short-circuit breaking capacity at 690 V~, eff. kA	Module size E = 25 mm	Equipment compartment	
			Width B1 mm	Depth T1 mm
160	50	8E	600	400
400	50	16E	600	400
736	50	24E	600	400

Moduled case circuit breaker, 3-pole

Switch Type	Rated current A	Rated short-circuit breaking capacity at 400 V~ kA	Module size E = 25 mm	Equipment compartment	
				Width B1 mm	Depth T1 mm
Motor-protecting switch	25	50	8E/4	(600)	400
	25	50	8E/2	(600)	400
	25	50	4E	600	400
Current limiter	32	50	8E/4	(600)	400
	32	50	8E/2	(600)	400
	45	50	8E/2	(600)	400
	63	50	8E/2	(600)	400
	125	170	8E	600	400
	200	200	8E	600	400
	320	200	8E, 16E ¹⁾	600	400
	500	200	16E	600	400
630	200	16E	600	400	
Zero-point circuit breaker	250	65, 85, 35-100	8E	600	400
	400	35-100	8E	600	400
	800	35-100	16E	600	400

¹⁾ Coupling

Moduled case circuit breaker, 4-pole

Switch Type	Rated current A	Rated short-circuit breaking capacity at 400 V~ kA	Module size E = 25 mm	Equipment compartment	
				Width B1 mm	Depth T1 mm
Current limiter	125	170	8E	600	400
	320	200	8E	600	400
	500	200	24E	600	400
	630	200	24E	600	400
Zero-point circuit breaker	160	65, 85, 35-100	8E	600	400
	250	65, 85, 35-100	16E	600	400
	400	35-100	16E	600	400
	800, 630 ¹⁾	35-100	24E	600	400

¹⁾ Coupling

For details, see the Technical Data Sheets

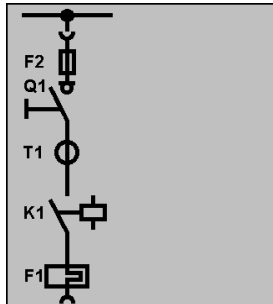

Non-reversing motor starter

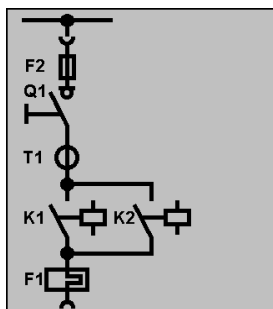

Reversing motor starter

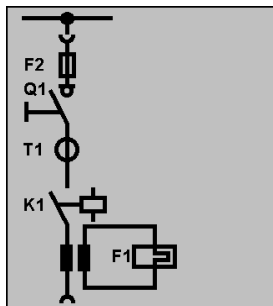

Heavy-duty motor starter

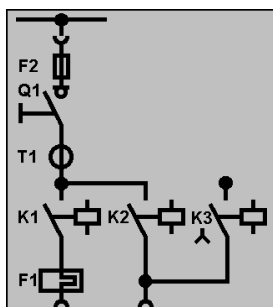

Star-delta motor starter

Standard type program Motor starters (fused and thermal relays)

Non-reversing and Reversing motor starter

Module size	Motor powers with AC3		Equipment compartment	
	Non-reversing 400 V ~ kW	Reversing 400 V ~ kW	Width B1 mm	Depth T1 mm
E = 25 mm				
8E/4	up to 22	up to 18,5	(600)	400
8E/2	up to 30	up to 30	(600)	400
4E	up to 30	up to 30	600	400
8E	up to 75	up to 37	600	400
12E	up to 160	up to 45	600	400
16E	up to 200	up to 110	600	400
20E	-	up to 160	600	400
24E	up to 315	up to 200	600	400
36E	-	up to 280	600	400
40E	-	up to 315	600	400

Heavy-duty and Star-delta motor starter

Module size	Motor powers with AC3		Equipment compartment	
	Heavy-duty 400 V ~ kW	Star-delta 400 V ~ kW	Width B1 mm	Depth T1 mm
E = 25 mm				
8E/4	-	-	(600)	400
8E/2	up to 30	up to 30	(600)	400
4E	up to 30	-	600	400
8E	up to 45	up to 55	600	400
12E	up to 110	up to 75	600	400
16E	up to 132	-	600	400
20E	-	up to 160	600	400
24E	up to 315	up to 200	600	400
36E	-	up to 315	600	400
40E	-	-	600	400

For details, see the Technical Data Sheets

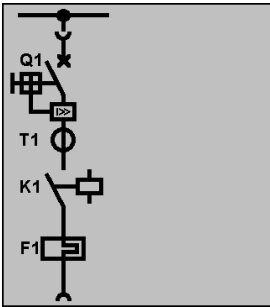

Non-reversing motor starter

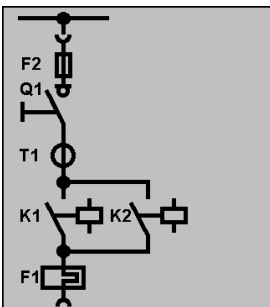

Reversing motor starter

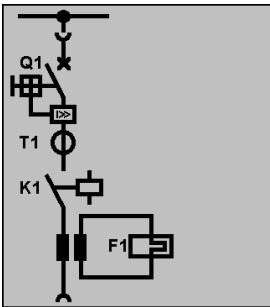

Heavy-duty motor starter

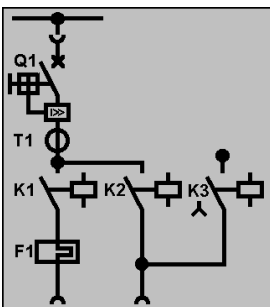

Star-delta motor starter

Standard type program motor starters (fuseless and thermal relays)

Non-reversing and Reversing motor starter

Module size	Motor powers with AC3		Equipment compartment	
	Non-reversing 400 V ~ kW	Reversing 400 V ~ kW	Width B1 mm	Depth T1 mm
E = 25 mm				
8E/4	up to 22	up to 22	(600)	400
8E/2	up to 22	up to 22	(600)	400
4E	up to 22	up to 22	600	400
8E	up to 55	up to 37	600	400
12E	up to 90	up to 90	600	400
16E	up to 110	up to 110	600	400
20E	up to 200	up to 132	600	400
24E	up to 250	-	600	400
36E	-	up to 250	600	400
40E	-	-	600	400

Heavy-duty and Star-delta motor starter

Module size	Motor powers with AC3		Equipment compartment	
	Heavy-duty 400 V ~ kW	Star-delta 400 V ~ kW	Width B1 mm	Depth T1 mm
E = 25 mm				
8E/4	-	-	(600)	400
8E/2	up to 22	up to 22	(600)	400
4E	up to 7,5	-	600	400
8E	up to 55	up to 22	600	400
12E	up to 75	up to 45	600	400
16E	up to 110	up to 75	600	400
20E	up to 200	up to 132	600	400
24E	up to 250	-	600	400
36E	-	up to 160	600	400
40E	-	-	600	400

For details, see the Technical Data Sheets

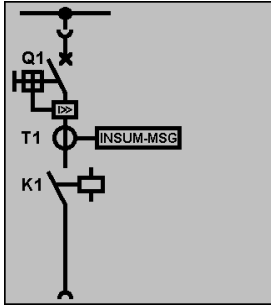

Motor starter with INSUM®
Non-reversing and
Heavy-duty

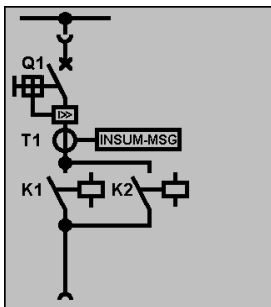

Motor starter with INSUM®
Reversing

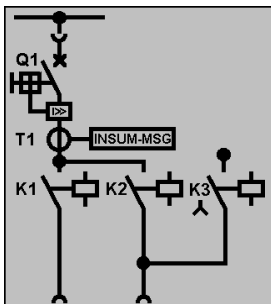

Motor starter with INSUM®
Star-delta motor starter

Standard type program motor starters (fuseless and INSUM®)

Non-reversing and Reversing motor starter

Module size E = 25 mm	Motor powers with AC3 400 V ~ kW		Equipment compartment Width B1 mm	Equipment compartment Depth T1 mm
	Non-reversing	Reversing		
8E/4	up to 22	up to 22	(600)	400
8E/2	up to 22	up to 22	(600)	400
4E	up to 22	up to 22	600	400
8E	up to 55	up to 37	600	400
12E	up to 90	up to 90	600	400
16E	up to 110	up to 110	600	400
20E	up to 200	up to 132	600	400
24E	up to 250	-	600	400
36E	-	up to 250	600	400
40E	-	-	600	400

Heavy-duty and Star-delta motor starter

Module size E = 25 mm	Motor powers with AC3 400 V ~ kW		Equipment compartment Width B1 mm	Equipment compartment Depth T1 mm
	Heavy-duty	Star-delta		
8E/4	-	-	(600)	400
8E/2	up to 22	up to 22	(600)	400
4E	up to 7,5	-	600	400
8E	up to 55	up to 22	600	400
12E	up to 75	up to 45	600	400
16E	up to 110	up to 75	600	400
20E	up to 200	up to 132	600	400
24E	up to 250	-	600	400
36E	-	up to 160	600	400
40E	-	-	600	400

For details, see the Technical Data Sheets

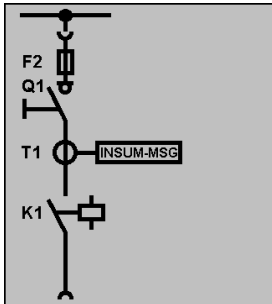

Motor starter with INSUM®
Non-reversing and
Heavy-duty

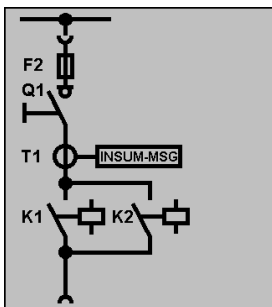

Motor starter with INSUM®
Reversing

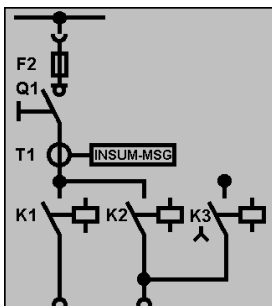

Motor starter with INSUM®
Star-delta motor starter

Standard type program motor starters (fused and INSUM®)

Non-reversing and Reversing motor starter

Module size	Motor powers with AC3		Equipment compartment	
	Non-reversing 400 V ~ kW	Reversing 400 V ~ kW	Width B1 mm	Depth T1 mm
E = 25 mm				
8E/4	up to 22	up to 15	(600)	400
8E/2	up to 30	up to 30	(600)	400
4E	up to 30	up to 30	600	400
8E	up to 75	up to 37	600	400
12E	up to 160	up to 45	600	400
16E	up to 200	up to 110	600	400
20E	-	up to 160	600	400
24E	up to 315	up to 200	600	400
36E	-	up to 280	600	400
40E	-	up to 315	600	400

Heavy-duty and Star-delta motor starter

Module size	Motor powers with AC3		Equipment compartment	
	Heavy-duty 400 V ~ kW	Star-delta 400 V ~ kW	Width B1 mm	Depth T1 mm
E = 25 mm				
8E/4	-	-	(600)	400
8E/2	up to 30	up to 30	(600)	400
4E	up to 30	-	600	400
8E	up to 45	up to 55	600	400
12E	up to 110	up to 75	600	400
16E	up to 132	-	600	400
20E	-	up to 160	600	400
24E	up to 315	up to 200	600	400
36E	-	up to 315	600	400
40E	-	-	600	400

For details, see the Technical Data Sheets

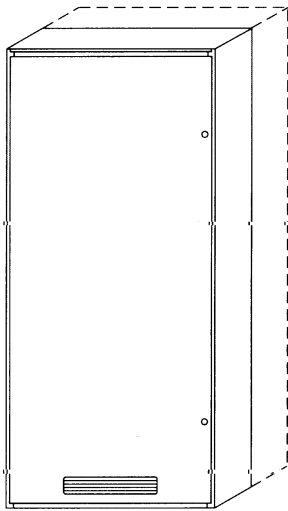

Control cubicle with cubicle door

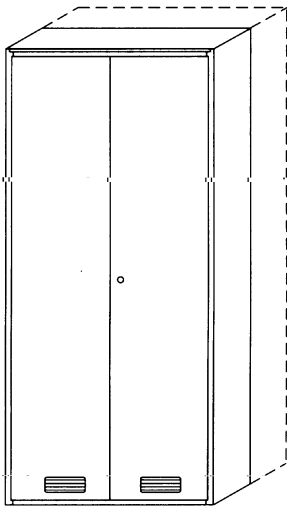

Control cubicle with equipment compartment and double door

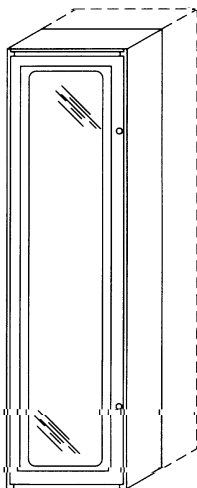

Control cubicle with cubicle door with inspection window

Control cubicles

For free project engineering of cubicles for open and closed-loop control purposes (e. g. electronic cubicles), standardized empty cubicles with an equipment compartment, but without a cable or busbar compartment, with the dimensions (H x W x D) of 2200 mm x 800 / 1000 mm x 400 ... 1000 mm are provided in the MNS system.

The front side can be designed with a continuous cubicle door, door with window, double door with espagnolette-type lock, or with module doors. For individual interior arrangements, mounting plates are available.

The control modules are designed for an equipment compartment width of 600 mm and are therefore ideally suitable for a combination with power modules. Mounting of control modules on one side of cubicles is possible as well as in cubicles with a hinged frame.

Pug-In-mounted modules for control applications are designed analogously to modules used for power applications. Their basic elements are equipment supporting rails of aluminium with an integrated profile according to DIN 46277 for snap-on mounting of equipment. Wiring ducts or wire supporting clips for accommodating cables are arranged between the equipment mounting level. wiring, however, is performed from the front side. The wiring ducts or spaces between the wire supporting clips can be closed by a cover.

The number of supporting rails and thus also the module height is not restricted. The control cables and wires are connected to terminals mounted to the vertical terminal mounting rail at the right-hand side.

Mounting frames are available for complex control systems with cubicle width 800 and 1000mm. Their design is basically the same as that for fixed-mounted control modules. To carry the cables running in parallel to the mounting rail, wiring supporting clips, which protrude from the installation level towards the rear, are installed between any two mounting rails or between mounting rails and closing rails. The wiring space can be closed by a cable duct over. The brackets mounted on both sides accommodate the vertical cables. Vertical terminal strips are arranged on the right or on both sides as required.

Hinged frame or electronic subracks

The hinged frame for electronic subrack serves as a support for module racks. It is installed at the cubicle front in a way hinged like a door. Its front side can be equipped with electronic subracks and instrument covers, and its rear side can carry control modules.

The mounting surface of the hinged frame can be covered with an additional door with or without an inspection window.

Hinged frames that do not take the entire cubicle height can be combined with module doors.

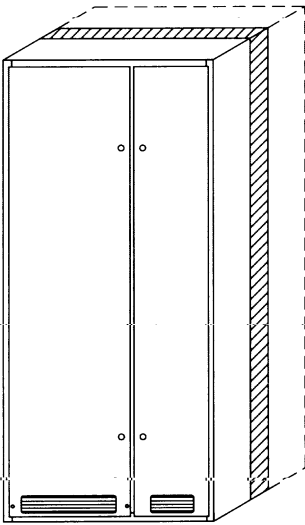

Power cubicle with equipment, cable, and busbar compartments, with continuous doors

Power cubicles

For free project engineering of, e. g., outgoing feeder cubicles, the MNS system provides empty cubicles as standardized modules size (H x W x D) 2200 mm x 800/1000 mm x 400 ... 1000 mm with equipment, cable and busbar compartments.

The front can be designed with a continuous cubicle door, continuous equipment and cable compartment doors, or an equipment compartment door (72E) and front covers for the PEN busbar and control cable duct.

Empty cubicles, standard modules

Description	Cubicle width mm	Cubicle depth mm
Incoming cubicle	400 ¹⁾ , 600, 800, 1000	600, 800, 1000, 1200
Outgoing cubicle	600 ¹⁾ , 800, 1000	600, 800, 1000, 1200
Control cubicle		
- with busbar compartment	400, 600, 800, 1000	600, 800, 1000, 1200
- without busbar compartment	600, 800, 1000	600, 800, 1000, 1200
- Back to back cubicle	800, 1000	800, 1000
IP54-Cubicle		
- Incoming cubicle	1000	600, 800, 1000, 1200
- Outgoing cubicle	1000	600, 800, 1000, 1200
Back to back cubicle		
- Control cubicle	800, 1000	800, 1000
- Outgoing cubicle	800, 1000	600, 1000
Busbar change-over cubicle	200, 400	400, 600, 800, 1000, 1200

¹⁾ without cable compartment